

TECHNICAL MANUAL

AVIATION UNIT AND
AVIATION INTERMEDIATE
TROUBLESHOOTING MANUAL
CH-47D HELICOPTER

This copy is a reprint which includes current
pages from Changes 1 through 17.

HEADQUARTERS, DEPARTMENT OF THE ARMY

10 MAY 1983

CHANGE

NO. 24

HEADQUARTERS
DEPARTMENT OF THE ARMY
WASHINGTON, D.C., 30 September 2003

**Aviation Unit and Aviation Intermediate
Troubleshooting Manual**

CH-47D HELICOPTER

DISTRIBUTION STATEMENT A: Approved for public release; distribution is unlimited.

TM 55-1520-240-T-3, 10 May 1983 is changed as follows:

1. Remove and insert pages as indicated below. New or changed text material is indicated by a vertical bar in the margin. An illustration change is indicated by a miniature pointing hand.

Remove pages

A through C/(D blank)
iii/(iv blank)
16-2.1 through 16-2.4

Index-3 and Index-4

Insert pages

A through D
iii/(iv blank)
16-2.1 through 16-2.4
16-2.6.3/(16-2.6.4 blank)
16-181 through 16-224
16-225/(16-226 blank)
Index-3 and Index-4

2. Retain this sheet in front of the manual for reference purposes.

By order of the Secretary of the Army:

Official:

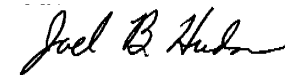

JOEL B. HUDSON
Administrative Assistant to the
Secretary of the Army
0321102

PETER J. SCHOOMAKER
General, United States Army
Chief of Staff

DISTRIBUTION:

To be distributed in accordance with Initial Distribution Number (IDN) 311212, requirements for
TM 55-1520-240-T-3

CHANGE

NO. 23

**Aviation Unit and Aviation Intermediate
Troubleshooting Manual**

CH-47D HELICOPTER

DISTRIBUTION STATEMENT A: Approved for public release; distribution is unlimited

TM 55-1520-240-T-3, 10 May 1983 is changed as follows:

1. Remove and insert pages as indicated below. New or changed text material is indicated by a vertical bar in the margin. An illustration change is indicated by a miniature pointing hand.

Remove pages

A through C/(D blank)
i through iii/(iv blank)
10-2.3 through 10-2.6
10-35 through 10-38
10-41 and 10-42
10-79 through 10-98
11-2.1 through 11-2.3/(11-2.4 blank)
11-2.4.3 and 11-2.4.4
11-2.5 through 11-2.8
11-37 and 11-38
11-42.11 and 11-42.12
11-49 through 11-58
11-75 through 11-80
11-87 through 11-90
11-90.1/(11-90.2 blank)
11-111 through 11-114
11-114.1/(11-114.2 blank)
12-2.3 and 12-2.4
12-33 and 12-34

12-37 and 12-38

12-39 and 12-40

12-41 through 12-44

12-47 and 12-48

12-55 through 12-68
13-2.1 through 13-2.4
13-2.7 and 13-2.8
13-3 through 13-8
13-27 and 13-28
15-7 through 15-10

Insert pages

A through C/(D blank)
i through iii/(iv blank)
10-2.3 through 10-2.6
10-35 through 10-38
10-41 and 10-42
10-79 through 10-98
11-2.1 through 11-2.3/(11-2.4 blank)
11-2.4.3 and 11-2.4.4
11-2.5 through 11-2.8
11-37 and 11-38
11-42.11 and 11-42.12
11-49 through 11-58
11-75 through 11-80
11-87 through 11-90
11-90.1 and 11-90.2
11-111 through 11-114
11-114.1 and 11-114.2
12-2.3 and 12-2.4
12-33 and 12-34
12-34.1/(12-34.2 blank)
12-37 and 12-38
12-38.1/(12-38.2 blank)
12-39 and 12-40
12-40.1/(12-40.2 blank)
12-41 through 12-44
12-44.1/(12-44.2 blank)
12-47 and 12-48
12-48.1/(12-48.2 blank)
12-55 through 12-68
13-2.1 through 13-2.4
13-2.7 and 13-2.8
13-3 through 13-8
13-27 and 13-28
15-7 through 15-10

Remove Pages

15-11 and 15-12

15-13 through 15-17/(15-18 blank)
15-21 through 15-24
15-27 through 15-32
15-35 through 15-38
15-43 through 15-46
15-57 through 15-60
15-69 through 15-72
15-89 and 15-90

15-91 through 15-93/(15-94 blank)

15-95 and 15-96

15-97 and 15-98

15-99 and 15-100
15-109 through 15-112
15-117 through 15-132
15-135 and 15-136
16-2.3 through 16-2.6

16-3 through 16-6
16-10 through 16-16
16-19 and 16-20
16-33 through 16-38
16-41 through 16-44
16-53 through 16-56
16-59 through 16-66
Index-1 through Index-9/(-10 blank)

Insert Pages

15-10.1 and 15-10.2
15-11 and 15-12
15-12.1/(15-12.2 blank)
15-13 through 15-17/(15-18 blank)
15-21 through 15-24
15-27 through 15-32
15-35 through 15-38
15-43 through 15-46
15-57 through 15-60
15-69 through 15-72
15-89 and 15-90
15-90.1/(15-90.2 blank)
15-91 through 15-94
15-94.1 and 15-94.2
15-95 and 15-96
15-96.1 and 15-96.2
15-97 and 15-98
15-98.1 and 15-98.2
15-99 and 15-100
15-109 through 15-112
15-117 through 15-132
15-135 and 15-136
16-2.3 through 16-2.6
16-2.9 and 16-2.10
16-3 through 16-6
16-10 through 16-16
16-19 and 16-20
16-33 through 16-38
16-41 through 16-44
16-53 through 16-56
16-59 through 16-66
Index-1 through Index-9/(-10 blank)

2. Retain this sheet in front of the manual for reference purposes.

By Order of the Secretary of the Army:

Official:

JOEL B. HUDSON
*Administrative Assistant to the
Secretary of the Army*
0016605

ERIC K. SHINSEKI
*General, United States Army
Chief of Staff*

DISTRIBUTION:

To be distributed in accordance with Initial Distribution Number (IDN) 311212, requirements for TM 55-1520-240-T-3.

CHANGE

NO. 22

**Aviation Unit and Aviation Intermediate
Troubleshooting Manual**

CH-47D HELICOPTER

DISTRIBUTION STATEMENT A: Approved for public release; distribution is unlimited

TM 55-1520-240-T-3, 10 May 1983 is changed as follows:

1. Remove and insert pages as indicated below. New or changed text material is indicated by a vertical bar in the margin. An illustration change is indicated by a miniature pointing hand.

Remove pages

A through C/(D blank)
i and ii
vii and viii
10-2.3 and 10-2.4
10-2.7/(10-2.8 blank)
10-123 through 10-126
10-129 through 10-132

- - - -

Insert pages

A through C/(D blank)
i and ii
vii and viii
10-2.3 and 10-2.4
10-2.7/(10-2.8 blank)
10-123 through 10-126
10-129 through 10-132
10-179 through 10-182
(10-183 blank)/10-184
10-185 through 10-190
(10-191 blank)/10-192
10-193 and 10-194

2. Retain this sheet in front of the manual for reference purposes.

By Order of the Secretary of the Army:

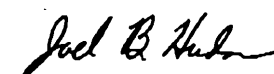

JOEL B. HUDSON
Administrative Assistant to the
Secretary of the Army
0008107

ERIC K. SHINSEKI
General, United States Army
Chief of Staff

Distribution:

To be distributed in accordance with Initial Distribution Number (IDN) 311212, requirements for
TM 55-1520-240-T-3.

HEADQUARTERS
DEPARTMENT OF THE ARMY
WASHINGTON, D.C., 30 April 1999

CHANGE

NO. 21

**Aviation Unit and Aviation Intermediate
Troubleshooting Manual**

CH-47D HELICOPTER

DISTRIBUTION STATEMENT A: Approved for public release; distribution is unlimited

TM 55-1520-240-T-3, 10 May 1983 is changed as follows:

1. Remove and insert pages as indicated below. New or changed text material is indicated by a vertical bar in the margin. An illustration change is indicated by a miniature pointing hand.

Remove pages	Insert pages
----	A-C/(D blank)
A/(B blank)	a/(b blank)
ii/(iv blank)	iii/(iv blank)
vii and viii	vii and viii
18-3 and 18-4	18-3 and 18-4
18-4.1 and 18-4.2	18-4.1 and 18-4.2
-----	18-6A/(18-6B blank)
-----	18-6.3 and 18-6.4
-----	18-97 through 18-142
Index-5 and Index-6	Index-5 and Index-6

2. Retain this sheet in front of the manual for reference purposes.

By Order of the Secretary of the Army:

Official:

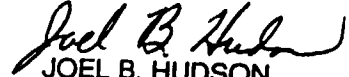
JOEL B. HUDSON
*Administrative Assistant to the
Secretary of the Army*
9914401

DENNIS J. REIMER
*General, United States Army
Chief of Staff*

DISTRIBUTION:

To be distributed in accordance with Initial Distribution Number (IDN) 311212, requirements for
TM 55-1520-240-T-3.

CHANGE

NO. 20

**Aviation Unit and Aviation Intermediate
Troubleshooting Manual**

CH-47D HELICOPTER

DISTRIBUTION STATEMENT A: Approved for public release; distribution is unlimited

TM 55-1520-240-T-3, 10 May 1983 is changed as follows:

1. Remove and insert pages as indicated below. New or changed text material is indicated by a vertical bar in the margin. An illustration change is indicated by a miniature pointing hand.

Remove pages

i through iii/(iv blank)
10-125 through 10-130

Insert pages

i through iii/(iv blank)
10-125 through 10-130

2. Retain this sheet in front of the manual for reference purposes.

By Order of the Secretary of the Army:

Official:

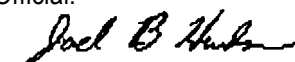

JOEL B. HUDSON
Administrative Assistant to the
Secretary of the Army

9913101

DENNIS J. REIMER
General, United States Army
Chief of Staff

DISTRIBUTION:

To be distributed in accordance with Initial Distribution Number (IDN) 311212, requirements for
TM 55-1520-246-T-3.

CHANGE
NO. 19

HEADQUARTERS
DEPARTMENT OF THE ARMY
WASHINGTON, D.C., 14 NOVEMBER 1997

Aviation Unit and Aviation Intermediate
Troubleshooting Manual

CH-47 HELICOPTER

DISTRIBUTION STATEMENT A: Approved for public release; distribution is unlimited.

TM 55-1520-240-T-3, 10 May 1983, is changed as follows:

1. Remove and insert pages as indicated below. New or changed text material is indicated by a vertical bar in the margin. An illustration change is indicated by a miniature pointing hand.

Remove Pages	Insert Pages
iii/(iv blank)	iii/(iv blank)
vii and viii	vii and viii
18-3 and 18-4	18-3 and 18-4
-----	18-4.1/(18-4.2 blank)
18-5/(18-6 blank)	18-5 and 18-6
-----	18-6.1 and 18-6.2
-----	18-61 through 18-95/(18-96 blank)
Index-3 and Index-4	Index-3 and Index -4
-----	Index-4.1/(Index-4.2 blank)

2. Retain this sheet in front of manual for reference purposes.

By Order of the Secretary of the Army:

Official:

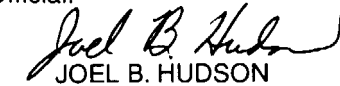
 JOEL B. HUDSON
 Administrative Assistant to the
 Secretary of the Army
 04355

DENNIS J. REIMER
General, United States Army
Chief of Staff

DISTRIBUTION:

To be distributed in accordance with Initial Distribution Number (IDN) 311212, requirements for
TM 55-1520-240-T-3.

CHANGE

NO. 18

TM 55-1520-240-T-3
C18

HEADQUARTERS,
DEPARTMENTS OF THE ARMY
WASHINGTON, D.C., 30 September 1996

Aviation Unit and Aviation Intermediate
Troubleshooting Manual

CH-47D HELICOPTER

DISTRIBUTION STATEMENT A: Approved for public release; distribution is unlimited

TM 55-1520-240-T-3, 10 May 1983, is changed as follows:

1. Remove and insert pages as indicated below. New or changed text material is indicated by a vertical bar in the margin. An illustration change is indicated by a miniature pointing hand.

Remove pages	Insert pages
III/(iv blank)	iii/(iv blank)
vii and viii	vii and viii
16-2.1 through 16-2.4	16-2.1 through 16-2.4
.....	16-2.6.1 /(16-2.6.2 blank)
.....	16-143 through 16-179/(16-180 blank)
.....	18-1 through 18-59(18-60 blank)
Index-1 through Index-9/(Index-10 blank)	Index-1 through Index-9/(Index-10 blank)

2. Retain this sheet in front of manual for reference purposes.

By Order of the Secretary of the Army:

DENNIS J. REIMER
General, United States Army
Chief of Staff

Official:

JOEL B. HUDSON
Administrative Assistant to the
Secretary of the Army

02563

DISTRIBUTION:

To be distributed in accordance with DA Form 12-31-E, block no. 1212. requirements for TM 55-1520-240-T-3.

HEADQUARTERS
DEPARTMENT OF THE ARMY
WASHINGTON, D.C., 31 January 1995

CHANGE

NO. 17

**Aviation Unit and Aviation intermediate
Troubleshooting Manual**

CH-47 Helicopter

DISTRIBUTION STATEMENT A: Approved for public release; distribution is unlimited

TM 55-1520-240-T-3, 10 May 1983, is changed as follows:

1. Remove and insert pages as indicated below. New or changed text material is indicated by a vertical bar in the margin. An illustration change is indicated by a miniature pointing hand.

Remove Pages	Insert Pages
10-39 and 10-40	10-39 and 10-40
11-89 and 11-90	11-89 and 11-90
11-113 and 11-114	11-113 and 11-114
11-145 and 11-146	11-145 and 11-146
15-119 and 15-120	15-119 and 15-120
15-123 and 15-124	15-123 and 15-124
15-127 and 15-128	15-127 and 15-128
15-131 through 15-134	15-131 through 15-134
16-75 and 16-76	16-75 and 16-76

2. Retain this sheet in front of manual for reference purposes.

By Order of the Secretary of the Army:

GORDON R. SULLIVAN
General, United States Army
Chief of Staff

Official:

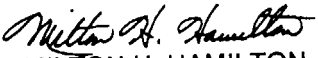
MILTON H. HAMILTON
Administrative Assistant to the
Secretary of the Army
07925

DISTRIBUTION:

To be distributed in accordance with DA Form 12-31-E, block no. 1212, requirements for TM 55-1520-240-T-3.

CHANGE

NO. 16

HEADQUARTERS
DEPARTMENT OF THE ARMY
WASHINGTON, D.C., 30 September 1994

Aviation Unit and Aviation Intermediate
Troubleshooting Manual

CH-47 HELICOPTER

DISTRIBUTION STATEMENT A: Approved for public release; distribution is unlimited

TM 55-1520-240-T-3, 10 May 1983, is changed as follows:

1. Remove and insert pages as indicated below. New or changed text material is indicated by a vertical bar in the margin. An illustration change is indicated by a miniature pointing hand.

Remove pages

iii/(iv blank)

Insert pages

iii/(iv blank)

16-109 through 16-142

2. Retain this sheet in front of manual for reference purposes.

By Order of the Secretary of the Army:

Official:



MILTON H. HAMILTON
Administrative Assistant to the
Secretary of the Army

07537

GORDON R. SULLIVAN
General, United States Army
Chief of Staff

DISTRIBUTION:

To be distributed in accordance with DA Form 12-31-E, block no. 1212, requirements for
TM 55-1520-240-T-3.

CHANGE

NO. 15

Aviation Unit and Aviation Intermediate
Troubleshooting Manual

CH-47 HELICOPTER

HEADQUARTERS
DEPARTMENT OF THE ARMY
WASHINGTON, D.C., 29 April 1994

DISTRIBUTION STATEMENT A: Approved for public release; distribution is unlimited

TM 55-1520-240-T-3, 10 May 1983, is changed as follows:

1. Remove and insert pages as indicated below. New or changed text material is indicated by a vertical bar in the margin. An illustration change is indicated by a miniature pointing hand.

Remove pages

vii/(viii blank)
10-2.3 and 10-2.4
10-2.5 and 10-2.6
10-35 through 10-40
10-83 and 10-84
10-91 and 10-92
10-95 and 10-96
10-99 and 10-100
10-111 and 10-112
11-42.11 and 11-42.12
11-42.17/(11-42.18 blank)
13-2.1 and 13-2.2
15-143/(15-144 blank)
16-15 and 16-16

Insert pages

vii and viii
10-2.3 and 10-2.4
10-2.5 and 10-2.6
10-35 through 10-40
10-83 and 10-84
10-91 and 10-92
10-95 and 10-96
10-99 and 10-100
10-111 and 10-112
11-42.11 and 11-42.12
11-42.17/(11-42.18 blank)
13-2.1 and 13-2.2
15-143/(15-144 blank)
16-15 and 16-16

2. Retain this sheet in front of manual for reference purposes.

By Order of the Secretary of the Army:

Official:

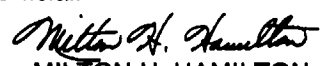
MILTON H. HAMILTON
Administrative Assistant to the
Secretary of the Army

06720

GORDON R. SULLIVAN
General, United States Army
Chief of Staff

DISTRIBUTION:

To be distributed in accordance with DA Form 12-31-E, block no. 1212, requirements for
TM 55-1520-240-T-3.

CHANGE

NO. 14

Aviation Unit and Aviation Intermediate
Troubleshooting Manual

CH-47D HELICOPTER

DISTRIBUTION STATEMENT A: Approved for public release; distribution is unlimited.

TM 55-1520-240-T-3, 10 May 1983, is changed as follows:

1. Remove and insert pages as indicated below. New or changed text material is indicated by a vertical bar in the margin. An illustration change is indicated by a miniature pointing hand.

Remove pages

11-41 and 11-42
11-203 and 11-204
11-221 and 11-222
11-231 through 11-236

Insert pages

11-41 and 11-42
11-203 and 11-204
11-221 and 11-222
11-231 through 11-236

2. Retain this sheet in front of manual for reference purposes.

By Order of the Secretary of the Army:

GORDON R. SULLIVAN
General, United States Army
Chief of Staff

Official:

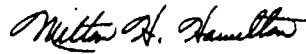
MILTON H. HAMILTON
Administrative Assistant to the
Secretary of the Army
04800

DISTRIBUTION:

To be distributed in accordance with DA Form 12-31-E, block no. 1212, requirements for TM 55-1520-240-T-3.

TM 55-1520-240-T-3
C 14

HEADQUARTERS
DEPARTMENT OF THE ARMY
WASHINGTON, D.C. 30 July 1993

CHANGE }
NO. 13 }

HEADQUARTERS
DEPARTMENT OF THE ARMY
WASHINGTON, D.C., 30 September 1992

Aviation Unit and Aviation Intermediate
Troubleshooting Manual

CH-47D HELICOPTER

TM 55-1520-240-T-3, 10 May 1983, is changed as follows:

1. Remove and insert pages as indicated below. New or changed text material is indicated by a vertical bar in the margin. An illustration change is indicated by a miniature pointing hand.

Remove pages	Insert pages
11-42.13 and 11-42.14	11-42.13 and 11-42.14
11-87 and 11-88	11-87 and 11-88
11-209 through 11-222	11-209 through 11-222
11-227/11-228	11-227/11-228

2. Retain this sheet in front of manual for reference purposes.

By Order of the Secretary of the Army:

Official:

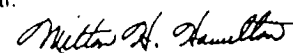

MILTON H. HAMILTON
Administrative Assistant to the
Secretary of the Army

02572

GORDON R. SULLIVAN
General, United States Army
Chief of Staff

DISTRIBUTION:

To be distributed in accordance with DA Form 12-31-E, block no. 1212, requirements for TM 55-1520-240-T-3.

DISTRIBUTION STATEMENT A: Approved for public release; distribution is unlimited.

HEADQUARTERS
DEPARTMENT OF THE ARMY
WASHINGTON, D.C., 30 April 1992

CHANGE }
NO. 12 }

Aviation Unit and Aviation Intermediate
Troubleshooting Manual

CH-47D HELICOPTER

TM 55-1520-240-T-3, 10 May 1983, is changed as follows:

1. Remove and insert pages as indicated below. New or changed text material is indicated by a vertical bar in the margin. An illustration change is indicated by a miniature pointing hand.

Remove pages	Insert pages
vii and viii	vii/viii
11-13 and 11-14	11-13 and 11-14
11-45 and 11-46	11-45 and 11-46
11-51 and 11-52	11-51 and 11-52
11-55 and 11-56	11-55 and 11-56
12-17 and 12-18	12-17 and 12-18
12-59 and 12-60	12-59 and 12-60
16-78 through 16-82	16-78 through 16-82
16-86 through 16-100	16-86 through 16-100
16-103 through 16-106	16-103 through 16-106

2. Retain this sheet in front of manual for reference purposes.

By Order of the Secretary of the Army:

GORDON R. SULLIVAN
General, United States Army
Chief of Staff

Official:

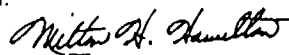
MILTON H. HAMILTON
Administrative Assistant to the
Secretary of the Army

01438

DISTRIBUTION:

To be distributed in accordance with DA Form 12-31-E, block no. 1212, AVUM and AVIM maintenance requirements for TM 55-1520-T-3.

CHANGE }
NO. 11 }

HEADQUARTERS
DEPARTMENT OF THE ARMY
WASHINGTON, D.C., 5 July 1991

Aviation Unit and Aviation Intermediate
Troubleshooting Manual

CH-47D HELICOPTER

TM 55-1520-240-T-3, 10 May 1983, is changed as follows:

1. Remove and insert pages as indicated below. New or changed text material is indicated by a vertical bar in the margin. An illustration change is indicated by a miniature pointing hand.

Remove pages

Insert pages

i and ii

i and ii

2. Retain this sheet in front of manual for reference purposes.

By Order of the Secretary of the Army:

CARLE E. VUONO
General, United States Army
Chief of Staff

Official:

PATRICIA P. HICKERSON
Colonel, United States Army
The Adjutant General

DISTRIBUTION:

To be distributed in accordance with DA Form 12-31-E, block no. 1212, AVUM and AVIM maintenance requirements for TM 55-1520-240-T-3.

CHANGE }
NO. 10 }HEADQUARTERS
DEPARTMENT OF THE ARMY
WASHINGTON, D.C., 19 November 1990Aviation Unit and Aviation Intermediate
Troubleshooting Manual

CH-47D HELICOPTER

TM 55-1520-240-T-3, 10 May 1983, is changed as follows:

1. Remove and insert pages as indicated below. New or changed text material is indicated by a vertical bar in the margin. An illustration change is indicated by a miniature pointing hand.

Remove pages	Insert pages
vii and viii	vii and viii
11-7/11-8	11-7/11-8
11-42.11 through 11-42.14	11-42.11 through 11-42.14
11-131 and 11-132	11-131 and 11-132
-----	11-132.1 through 11-132.6
11-134	11-134
11-134.1 through 11-134.7/11-134.8	-----
11-137 and 11-138	11-137 and 11-138
13-2.7 and 13-2.8	13-2.7 and 13-2.8
14-11 and 14-12	14-11 and 14-12
14-15 and 14-16	14-15 and 14-16
15-33 through 15-39/15-40	15-33 through 15-39/15-40
15-43 through 15-47/15-48	15-43 through 15-47/15-48
15-79 through 15-82	15-79 through 15-82
15-123 and 15-124	15-123 and 15-124
15-131 and 15-132	15-131 and 15-132
15-135 and 15-136	15-135 and 15-136
16-11 and 16-12	16-11 and 16-12
16-15 and 16-16	16-15 and 16-16
16-49 and 16-50	16-49 and 16-50
16-83 and 16-84	16-83 and 16-84
16-93 and 16-94	16-93 and 16-94

2. Retain this sheet in front of manual for reference purposes.

By Order of the Secretary of the Army:

Official:

THOMAS F. SIKORA
Brigadier General, United States Army
The Adjutant General

CARLE. VUONO
General, United States Army
Chief of Staff

DISTRIBUTION:

To be distributed in accordance with DA Form 12-31, AVUM and AVIM Maintenance requirements for CH-47D Helicopter, Cargo Transport.

HEADQUARTERS
DEPARTMENT OF THE ARMY
WASHINGTON, D.C., 1 November 1989

CHANGE }
NO. 9 }

Aviation Unit and Aviation Intermediate
Troubleshooting Manual

CH-47D HELICOPTER

TM 55-1520-240-T-3, 10 May 1983, is changed as follows:

1. Remove and insert pages as indicated below. New or changed text material is indicated by a vertical bar in the margin. An illustration change is indicated by a miniature pointing hand.

Remove pages	Insert pages
v through vii/viii	v through viii
10-2.5 and 10-2.6	10-2.5 and 10-2.6
10-35 and 10-36	10-35 and 10-36
10-66.1/10-66.2	10-66.1/10-66.2
10-101 and 10-102	10-101 and 10-102
10-105 through 10-108	10-105 through 10-108
10-119 and 10-120	10-119 and 10-120
10-125 and 10-126	10-125 and 10-126
10-155 through 10-164	10-155 through 10-164
10-167 and 10-168	10-167 and 10-168
10-171 through 10-174	10-171 through 10-174
11-2.5 and 11-2.6	11-2.5 and 11-2.6
11-41 and 11-42	11-41 and 11-42
11-42.1 and 11-42.2	11-42.1 and 11-42.2
11-42.11 through 11-42.16	11-42.11 through 11-42.17/ 11-42.18
11-43 and 11-44	11-43 and 11-44
11-69 and 11-70	11-69 and 11-70
11-81 and 11-82	11-81/11-82
11-89 and 11-90	11-89 and 11-90
- - - -	11-90.1/11-90.2
11-113 and 11-114	11-113 and 11-114
- - - -	11-114.1/11-114.2
11-117 through 11-120	11-117 through 11-120
11-123 and 11-124	11-123 and 11-124
11-127 and 11-128	11-127 and 11-128
11-135 through 11-138	11-135 through 11-138
11-157 and 11-158	11-157 and 11-158
13-2.7 and 13-2.8	13-2.7 and 13-2.8
- - - -	13-2.8.1/13-2.8.2
13-3 and 13-4	13-3 and 13-4
13-13 and 13-14	13-13 and 13-14
14-9 and 14-10	14-9 and 14-10
16-2.5 through 16-2.8	16-2.5 through 16-2.8
16-7 and 16-8	16-7 and 16-8

Remove pages

16-10
16-13 through 16-16
- - - -
16-17 through 16-20
16-33 and 16-34
16-47 and 16-48
16-53 and 16-54
16-59 through 16-62
16-67 through 16-72
16-75 and 16-76
16-97 and 16-98

Insert pages

16-10
16-13 through 16-16
16-16.1/16-16.2
16-17 through 16-20
16-33 and 16-34
16-47 and 16-48
16-53 and 16-54
16-59 through 16-62
16-67 through 16-72
16-75 and 16-76
16-97 and 16-98

2. Retain this sheet in front of manual for reference purposes.

By Order of the Secretary of the Army:

CARL E. VUONO
General, United States Army
Chief of Staff

Official:

WILLIAM J. MEEHAN II
Brigadier General, United States Army
The Adjutant General

DISTRIBUTION:

To be distributed in accordance with DA Form 12-31, AVUM and AVIM Maintenance requirements for CH-47D Helicopter, Cargo Transport.

CHANGE }
NO. 8 }

HEADQUARTERS
DEPARTMENT OF THE ARMY
WASHINGTON, D.C., 22 June 1989

Aviation Unit and Aviation Intermediate
Troubleshooting Manual

CH-47D HELICOPTER

TM 55-1520-240-T-3, 10 May 1983, is changed as follows:

1. Remove and insert pages as indicated below. New or changed text material is indicated by a vertical bar in the margin. An illustration change is indicated by a miniature pointing hand.

Remove pages

i through iii/vi
v and vi
15-2.1 through 15-2.6
15-3 through 15-6
15-7 through 15-40

Index 1 through Index 8

Insert pages

i through iii/vi
v and vi

15-3 through 15-5/15-6
15-7 through 15-40
15-41 through 15-144
Index 1 through Index 8
Index 9/Index 10

2. Retain this sheet in front of manual for reference purposes.

By Order of the Secretary of the Army:

CARL E. VUONO
General, United States Army
Chief of Staff

Official:

WILLIAM J. MEEHAN II
Brigadier General, United States Army
The Adjutant General

DISTRIBUTION:

To be distributed in accordance with DA Form 12-31, AVUM and AVIM Maintenance requirements for CH-47D Helicopter, Cargo Transport.

CHANGE }
NO. 7 }

HEADQUARTERS
DEPARTMENT OF THE ARMY
WASHINGTON, D.C., 1 May 1988

Aviation Unit and Aviation Intermediate
Troubleshooting Manual

CH-47D HELICOPTER

TM 55-1520-240-T-3, 10 May 1983, is changed as follows:

1. Remove and insert pages as indicated below. New or changed text material is indicated by a vertical bar in the margin. An illustration change is indicated by a miniature pointing hand.

Remove pages	Insert pages
vii/viii	vii and viii
10-15 and 10-16	10-15 and 10-16
10-29 and 10-30	10-29 and 10-30
10-46.1/(10-46.2 Blank)	10-46.1/(10-46.2 Blank)
10-50.1/(10-50.2 Blank)	10-50.1/(10-50.2 Blank)
10-52.1/(10-52.2 Blank)	10-52.1/(10-52.2 Blank)
11-37 and 11-38	11-37 and 11-38
11-219 and 11-220	11-219 and 11-220
14-15 and 14-16	14-15 and 14-16
15-7 and 15-8	15-7 and 15-8
15-10	15-10
15-11 and 15-12	15-11 and 15-12
15-15 and 15-16	15-15 and 15-16
15-18	15-18
15-19 through 15-32	15-19 through 15-32
15-34	15-34
15-37 through 15-40	15-37 through 15-40
Index-1 and Index-2	Index-1 and Index-2

2. Retain this sheet in front of manual for reference purposes.

By Order of the Secretary of the Army:

CARL E. VUONO
General, United States Army
Chief of Staff

Official:

R. L. DILWORTH
Brigadier General, United States Army
The Adjutant General

CHANGE }
NO. 6 }

HEADQUARTERS
DEPARTMENT OF THE ARMY
WASHINGTON, D.C., 8 December 1987

Aviation Unit and Aviation Intermediate
Troubleshooting Manual

CH-47D HELICOPTER

TM 55-1520-240-T-3, 10 May 1983, is changed as follows:

1. Remove and insert pages as indicated below. New or changed text material is indicated by a vertical bar in the margin. An illustration change is indicated by a miniature pointing hand.

Remove pages

vii/viii
10-91 and 10-92
10-95 and 10-96
10-99 and 10-100
10-111 and 10-112
10-117 and 10-118
10-123 and 10-124
10-131 through 10-140
10-143 and 10-144
10-149 and 10-150
10-155 through 10-160
10-167 through 10-172
10-177/10-178
11-5 through 11-7/11-8
11-12 through 11-18
11-42.13 and 11-42.14
11-63 through 11-66
11-73 through 11-76
11-79 through 11-90
11-107 and 11-108
11-111 through 11-114
11-140.2
11-141 and 11-142
11-145 and 11-146
11-149 through 11-154
11-175 and 11-176
11-195 and 11-196
11-203 and 11-204
11-211 and 11-212
12-17 and 12-18
12-82
13-3 and 13-4
13-9 and 13-10
13-23 and 13-24
14-19 through 14-22
14-29 and 14-30
15-2.1 and 15-2.2
15-7 and 15-8

Insert pages

vii/viii
10-91 and 10-92
10-95 and 10-96
10-99 and 10-100
10-111 and 10-112
10-117 and 10-118
10-123 and 10-124
10-131 through 10-140
10-143 and 10-144
10-149 and 10-150
10-155 through 10-160
10-167 through 10-172
10-177/10-178
11-5 through 11-7/11-8
11-12 through 11-18
11-42.13 and 11-42.14
11-63 through 11-66
11-73 through 11-76
11-79 through 11-90
11-107 and 11-108
11-111 through 11-114
11-140.2
11-141 and 11-142
11-145 and 11-146
11-149 through 11-154
11-175 and 11-176
11-195 and 11-196
11-203 and 11-204
11-211 and 11-212
12-17 and 12-18
12-82
13-3 and 13-4
13-9 and 13-10
13-23 and 13-24
14-19 through 14-22
14-29 and 14-30
15-2.1 and 15-2.2
15-7 and 15-8

Remove pages

15-37/(15-38 blank)
16-43 and 16-44
16-83 and 16-84
16-86 through 16-88

Insert pages

15-37 and 15-38
16-43 and 16-44
16-83 and 16-84
16-86 through 16-88

2. Retain this sheet in front of manual for reference purposes.

By Order of the Secretary of the Army:

CARL E. VUONO
General, United States Army
Chief of Staff

Official:

R. L. DILWORTH
Brigadier General, United States Army
The Adjutant General

DISTRIBUTION:

To be distributed in accordance with DA Form 12-31, AVUM and AVIM Maintenance requirements for CH-47D Helicopter, Cargo Transport.

URGENT

TM 55-1520-240-T-3
C 5

CHANGE }
NO. 5 }

HEADQUARTERS
DEPARTMENT OF THE ARMY
WASHINGTON, D.C., 30 April 1987

Aviation Unit and Aviation Intermediate
Troubleshooting Manual

CH-47D HELICOPTER

TM 55-1520-240-T-3, 10 May 1983, is changed as follows:

1. Remove and insert pages as indicated below. New or changed text material is indicated by a vertical bar in the margin. An illustration change is indicated by a miniature pointing hand.

Remove pages

vii/(viii)
11-42.1 and 11-42.2
Index 5 and Index 6

Insert pages

vii/(viii)
11-42.1 and 11-42.2
Index 5 and Index 6

2. Retain this sheet in front of manual for reference purposes.

By Order of the Secretary of the Army:

JOHN A. WICKHAM, JR.
General, United States Army
Chief of Staff

Official:

R. L. DILWORTH
Brigadier General, United States Army
The Adjutant General

DISTRIBUTION:

To be distributed in accordance with DA Form 12-31, AVUM and AVIM Maintenance requirements for CH-47D Helicopter, Cargo Transport.

URGENT

URGENT

NOTICE: THIS CHANGE HAS BEEN PRINTED AND DISTRIBUTED OUT OF SEQUENCE. IT SHOULD BE INSERTED IN THE MANUAL AND USED. UPON RECEIPT OF THE EARLIER SEQUENCED CHANGE INSURE A MORE CURRENT CHANGE PAGE IS NOT REPLACED WITH A LESS CURRENT PAGE.

TM 55-1520-240-T-3

C 4

CHANGE }
NO. 4 }

HEADQUARTERS
DEPARTMENT OF THE ARMY
WASHINGTON, D.C., 29 July 1986

Aviation Unit and Aviation Intermediate
Troubleshooting Manual

CH-47D HELICOPTER

TM 55-1520-240-T-3, 10 May 1983, is changed as follows:

1. Remove and insert pages as indicated below. New or changed text material is indicated by a vertical bar in the margin. An illustration change is indicated by a miniature pointing hand.

Remove pages

- - -

Insert pages

11-134.1 through 11-134.7/11-134.8

2. Retain this sheet in front of manual for reference purposes.

By Order of the Secretary of the Army:

JOHN A. WICKHAM, JR.
General, United States Army
Chief of Staff

Official:

R. L. DILWORTH
Brigadier General, United States Army
The Adjutant General

DISTRIBUTION:

To be distributed in accordance with DA Form 12-31, AVUM and AVIM Maintenance requirements for CH-47D Helicopter, Cargo Transport.

URGENT

CHANGE }
NO. 3 }Aviation Unit and Aviation Intermediate
Troubleshooting Manual

CH-47D HELICOPTER

TM 55-1520-240-T-3, 10 May 1983, is changed as follows:

1. Remove and insert pages as indicated below. New or changed text material is indicated by a vertical bar in the margin. An illustration change is indicated by a miniature pointing hand.

Remove pages	Insert pages
i through iii/iv	i through iii/iv
v and vi	v and vi
---	vii/viii
10-2.3 through 10-2.7/10-2.8	10-2.3 through 10-2.7/10-2.8
---	10-2.9 and 10-2.10
10-3 and 10-4	10-3 and 10-4
10-35 through 10-40	10-35 through 10-40
10-43 and 10-44	10-43 and 10-44
---	10-44.1/10-44.2
10-46	10-45 and 10-46
---	10-46.1/10-46.2
10-47 and 10-48	10-47 and 10-48
---	10-48.1/10-48.2
10-49 and 10-50	10-49 and 10-50
---	10-50.1/10-50.2
10-51 and 10-52	10-51 and 10-52
---	10-52.1/10-52.2
10-53 through 10-62	10-53 through 10-62
---	10-62.1/10-62.2
10-63 and 10-64	10-63 and 10-64
---	10-64.1/10-64.2
10-65 and 10-66	10 65 and 10-66
---	10-66.1/10-66.2
10-67 and 10-68	10-67 and 10-68
---	10-68.1/10-68.2
10-69 through 10-76	10-69 through 10-76
10-81 through 10-86	10-81 through 10-86
10-89 through 10-100	10-89 through 10-100
10-103 and 10-104	10-103 and 10-104
10-109 and 10-110	10-109 and 10-110
10-115 and 10-116	10-115 and 10-116
10-125 through 10-128	10-125 through 10-128
10-131 and 10-132	10-131 and 10-132
10-147 and 10-148	10-147 and 10-148
10-163 and 10-164	10-163 and 10-164
10-173 and 10-174	10-173 and 10-174

Remove pages

11-2.1 through 11-2.4
 11-2.4.1 through 11-2.4.4
 11-2.5 and 11-2.6
 11-9 and 11-10
 11-35 through 11-42

 11-43 and 11-44
 11-67 and 11-68
 11-87 through 11-90
 11-111 through 11-114
 11-163 through 11-166
 11-171 through 11-174
 11-183 and 11-184
 11-187 and 11-188
 12-2.1 through 12-2.4
 13-2.1 through 13-2.4
 13-3 and 13-4
 14-2.1 and 14-2.2
 14-3 and 14-4
 15-2.1 through 15-2.4
 15-5 and 15-6
 15-13 and 15-14
 16-1/16-2
 16-2.1 through 16-2.6
 16-5 and 16-6
 16-31 and 16-32
 16-75 and 16-76
 16-99 through 16-107/16-108
 17-2.1 and 17-2.2
 17-2.5 and 17-2.6
 17-3 through 17-10
 17-12 through 17-14
 17-16 through 17-19/17-20

Insert pages

11-2.1 through 11-2.3/11-2.4
 11-2.4.1 through 11-2.4.4
 11-2.5 and 11-2.6
 11-9 and 11-10
 11-35 through 11-42
 11-42.1 through 11-42.8/
 11-42.9
 11-42.10 through 11-42.16
 11-43 and 11-44
 11-67 and 11-68
 11-87 through 11-90
 11-111 through 11-114
 11-163 through 11-166
 11-171 through 11-174
 11-183 and 11-184
 11-187 and 11-188
 12-2.1 through 12-2.4
 13-2.1 through 13-2.4
 13-3 and 13-4
 -2.1 and 14-2.2
 14-3 and 14-4
 15-2.1 through 15-2.4
 15-5 and 15-6
 15-13 and 15-14
 16-1/16-2
 16-2.1 through 16-2.6
 16-5 and 16-6
 16-31 and 16-32
 16-75 and 16-76
 16-99 through 16-107/16-108
 17-2.1 and 17-2.2
 17-2.5 and 17-2.6
 17-3 through 17-10/17-11
 17-12 through 17-14/17-15
 17-16 through 17-19/17-20

2. Retain these sheets in front of manual for reference purposes.

By Order of the Secretary of the Army:

JOHN A. WICKHAM, JR.
General, United States Army
Chief of Staff

Official:

R. L. DILWORTH
Brigadier General, United States Army
The Adjutant General

DISTRIBUTION:

To be distributed in accordance with DA Form 12-31, AVUM and AVIM requirements for CH-47D Helicopter, Cargo Transport.

CHANGE NO. }
 NO. 2 }

HEADQUARTERS
 DEPARTMENT OF THE ARMY
 WASHINGTON, DC., 19 April 1985

Aviation Unit and Aviation Intermediate
 Troubleshooting Manual

CH-47D HELICOPTER

TM 55-1520-240-T-3, 10 May 1983, is changed as follows:

1. Remove and insert pages as indicated below. New or changed text material is indicated by a vertical bar in the margin. An illustration change is indicated by a miniature pointing hand.

Remove pages

v and vi
 10-2.1 and 10-2.2
 10-35 through 10-44
 10-59 through 10-62
 10-75 through 10-84
 10-87 and 10-88
 10-91 and 10-92
 10-95 and 10-96
 10-99 and 10-100
 10-105 and 10-106
 10-111 and 10-112
 10-117 and 10-118
 10-123 through 10-126
 10-128
 10-151 and 10-152
 10-153 and 10-154
 10-161 through 10-164
 10-173 and 10-174
 10-175/10-176

11-2.1 through 11-2.4

11-9 and 11-10
 11-13 and 11-14
 11-17 and 11-18
 11-23 through 11-26
 11-29 through 11-32
 11-35 through 11-38
 11-41 and 11-42
 11-49 through 11-60
 11-77 and 11-78
 11-85 through 11-90
 11-93 through 11-100
 11-103 through 11-114

Insert pages

v and vi
 10-2.1 and 10-2.2
 10-35 through 10-44
 10-59 through 10-62
 10-75 through 10-84
 10-87 and 10-88
 10-91 and 10-92
 10-95 and 10-96
 10-99 and 10-100
 10-105 and 10-106
 10-111 and 10-112
 10-117 and 10-118
 10-123 through 10-126
 10-127 and 10-128
 10-151
 10-154
 10-161 through 10-164
 10-173 and 10-174
 10-175 and 10-176
 10-177/10-178
 11-2.1 through 11-2.4
 11-2.4.1 through 11-2.4.4
 11-9 and 11-10
 11-13 and 11-14
 11-17 and 11-18
 11-23 through 11-26
 11-29 through 11-32
 11-35 through 11-38
 11-41 and 11-42
 11-49 through 11-60
 11-77 and 11-78
 11-85 through 11-90
 11-93 through 11-100
 11-103 through 11-114

Remove pages

11-117 through 11-124
 11-127 through 11-132
 11-135 through 11-138
 11-141 and 11-142
 11-145 and 11-146
 11-149 through 11-152
 11-155 through 11-158
 11-177 through 11-180
 11-189/11-190
 12-45 and 12-46
 14-17 and 14-18
 15-3 and 15-4
 15-7 and 15-8
 15-10
 15-11 through 15-16
 15-18 through 15-24
 15-31 and 15-32
 16-2.1 and 16-2.2
 16-5 and 16-6
 16-15 and 16-16
 16-43 and 16-44
 16-47 and 16-48
 16-51 and 16-52
 16-55 and 16-56
 16-59 and 16-60
 16-65 through 16-68
 16-75 and 16-76
 16-79 through 16-82
 16-91 through 16-95/16-96
 17-2.1 and 17-2.2
 17-2.5 and 17-2.6
 17-3 through 17-6
 17-9 and 17-10

Insert pages

11-117 through 11-124
 11-127 through 11-132
 11-135 through 11-138
 11-140.2
 11-141 and 11-142
 11-145 and 11-146
 11-149 through 11-152
 11-155 through 11-158
 11-177 through 11-180
 11-189/11-190
 12-45 and 12-46
 14-17 and 14-18
 15-3 and 15-4
 15-7 and 15-8
 15-10
 15-11 through 15-16
 15-18 through 15-24
 15-31 and 15-32
 16-2.1 and 16-2.2
 16-5 and 16-6
 16-15 and 16-16
 16-43 and 16-44
 16-47 and 16-48
 16-51 and 16-52
 16-55 and 16-56
 16-59 and 16-60
 16-65 through 16-68
 16-75 and 16-76
 16-79 through 16-82
 16-91 through 16-96
 16-97 through 16-107/16-108
 17-2.1 and 17-2.2
 17-2.5 and 17-2.6
 17-3 through 17-6
 17-9 and 17-10
 17-16 through 17-19/17-20

2. Retain these sheets in front of manual for reference purposes.

By Order of the Secretary of the Army:

JOHN A. WICKHAM, JR.
General, United States Army
Chief of Staff

Official:

DONALD J. DELANDRO
Brigadier General, United States Army
The Adjutant General

DISTRIBUTION:

To be distributed in accordance with DA Form 12-31, Organizational Maintenance requirements for CH-47D aircraft.

URGENT

TM 55-1520-240-T-3
C 1

CHANGE }
NO. 1 }

HEADQUARTERS
DEPARTMENT OF THE ARMY
WASHINGTON, D.C., 23 July 1984

Aviation Unit and Aviation Intermediate Troubleshooting Manual

CH-47D HELICOPTER

TM 55-1520-240-T, 10 May 1983, is changed as follows:

1. Remove and insert pages as indicated below. New or changed text material is indicated by a vertical bar in the margin. An illustration change is indicated by a miniature pointing hand.

Remove pages

11-43 and 11-44
11-65 and 11-66

Insert pages

11-43 and 11-44
11-65 and 11-66

2. Retain this sheet in front of manual for reference purposes.

By Order of the Secretary of the Army:

JOHN A. WICKHAM, JR.
General, United States Army
Chief of Staff

Official:

ROBERT M. JOYCE
Major General, United States Army
The Adjutant General

DISTRIBUTION:

To be distributed in accordance with DA Form 12-31, Organizational Maintenance requirements for CH-47B/C & D aircraft.

URGENT

WARNING AND FIRST AID DATA.

Warnings, cautions, and notes emphasize important critical instructions. They are defined as follows:

WARNING

An operating procedure or practice which, if not correctly followed, will result in personnel injury or loss of life.

CAUTION

An operating procedure or practice which, if not strictly observed, will result in damage or destruction of equipment.

NOTE

An operating procedure or condition which it is essential to highlight.

Personnel performing instructions involving operations, procedures, materials, and practices which are included or implied in this technical manual shall observe the following instructions. Disregard of these warnings and precautionary information can cause serious injury or death. Refer to FM 21-11 for first aid data to treat injuries resulting from working on the helicopter.

Dangerous Static Charges. Ground the helicopter during parking, fueling, or defueling.

Dangerous Voltage Exist in the Electronic Equipment. Be careful when working on the 150- and 300-volt dc circuits and on the ac generator 115 and 200 volt ac outputs.

Dangerous Voltage may Exist at Antenna Terminals. Be careful when working near the antenna or the antenna terminals. Radio-frequency (rf) high voltages exist at these points when transmitters are operating. Contact with radiating antennas can cause serious rf burns.

Poisonous Carbon Monoxide Fumes. Toxic carbon monoxide fumes may be present inside the helicopter whenever the apu or engines are operating with the cargo ramp open. Ventilate the cockpit.

Dangerous Fuel Handling. Incorrect fuel handling causes fire hazards. Ground the helicopter when fueling or defueling.

Corrosive Battery Electrolyte (Potassium Hydroxide). Wear rubber gloves, apron, and face shield when handling leaking batteries. If potassium hydroxide is spilled on clothing, or other material wash immediately with clean water. If personnel contact is made, immediately start flushing the affected area with clean water. Continue washing until medical assistance arrives.

Acids and Alkalines. Do not add water to acids. A violent action will result. Acids should be added to water in small quantities. Ruststripper is an alkaline solution. Avoid contact with the skin. Wear protective clothing. Wash thoroughly after using.

Solvent and Cleaning Solutions. These materials are generally toxic and many (toluene, benzene, xylene, methyl-ethyl-ketone, perchlorethylene, naphtha, trichloroethylene) are highly flammable. Work in a well ventilated area away from open flames. Avoid inhaling fumes and prolonged contact with the skin. Wear protective clothing and goggles. Wash thoroughly after using.

Windshield Repellant. Do not let windshield rain repellant contact open flame. Deadly hydrogen fluoride gas could be generated. Wash hands with soap and water after handling repellant.

Antiseize Compounds. Some antiseize compounds are irritants. Avoid inhaling fumes and contact with the skin. Wear protective clothing. Wash thoroughly after using.

Paints, Varnishes, Dopes, Thinners, Lubricants, and Fuels. These materials are generally highly flammable and may be irritants. Work in a well ventilated area away from open flames. Avoid inhaling fumes and prolonged contact with the skin. Wash thoroughly after using.

Epoxy Resins, Cements, and Adhesives. These materials may contain toxic or irritating substances. They may also be flammable. Work in a well ventilated area away from open flames. Wear protective clothing. Avoid contact with the skin. Wash thoroughly after using.

Radiation Hazard. Some instruments contain radioactive material. (See TB 55-1500-314-25.) Do not try to disassemble these instruments. They present no radiation hazard unless seal is broken. If you think seal is broken, do not remove instrument from aircraft until you consult Base Radioactive Protection Officer (AR 40-15). Use a beta-gamma radiac meter AN/PDR-27 or equivalent to determine if instrument contains radioactive material (radium).

Fin Extinguishing Agents. Avoid repeated or prolonged exposure to high concentration of bromochloromethane (CB) or decomposition products. CB is a narcotic agent of moderate intensity but prolonged duration. It is less toxic than carbon tetrachloride, methylbromide, or products of combustion. Take normal precautions while using bromochloromethane. Use oxygen masks when available.

Monobromotrifluoromethane (**CF₃Br**) is highly volatile but is not easily detected by its odor. Although nontoxic, it is about the same as other freons and carbon dioxide, causing danger to personnel primarily by reduction of oxygen available for proper breathing. Do not allow the liquid to come into contact with your skin. It may cause frostbite or low temperature burns.

Noise. Sound pressure levels in this aircraft during some operating conditions exceed the Surgeon General's hearing conservation criteria, as defined in TB MED 251. Hearing protection devices, such as the aviator helmet or ear plugs, are required to be worn by all personnel in and around the aircraft during its operation.

FOD. Make sure area is clear of foreign objects before closing access doors, panels, and fairings. If the area is not cleared, damage to components and systems could result in personal injury or death.

Hydraulic Pressures. High pressures used in testing hydraulic components can cause line rupture or component failure. Only qualified personnel shall operate, service and maintain hydraulic test equipment. Use heavy plastic shielding, 1/2-inch thickness or more, when applying pressures over 250 psi, to prevent injury to personnel.

Compressed Air. Do not use more than 30 psi compressed air for cleaning purposes. Debris trajected under pressure can cause injury to eyes. Use source of compressed air under 30 psi and eye protection to prevent injury to personnel.

Flare Dispenser. Remove all power from helicopter before installing loaded payload module on dispenser assembly. Keep hands and face away from end of payload module during installation. Flares can accidentally fire, sometimes from stray voltage, resulting in injury or death.

LIST OF EFFECTIVE PAGES

Insert latest changed pages; dispose of superseded pages in accordance with regulations.

NOTE: On a changed page, the portion of the text affected by the latest change is indicated by a vertical line in the outer margin of the page. Changes to illustrations are indicated by miniature pointing hands.

Dates of issue for original and changed pages are:

Original	10 May 1983	Change 7	1 May 1988	Change 14	30 July 1993	Change 20	16 October 1998
Change 1	23 July 1984	Change 8	22 June 1989	Change 15	29 April 1994	Change 21	30 April 1999
Change 2	19 April 1985	Change 9	1 November 1989	Change 16	30 September 1994	Change 22	15 May 2000
Change 3	1 July 1986	Change 10	19 November 1990	Change 17	31 January 1995	Change 23	15 July 2000
Change 4	29 July 1986	Change 11	5 July 1991	Change 18	30 September 1996	Change 24	30 September 2003
Change 5	30 April 1987	Change 12	30 April 1992	Change 19	14 November 1997		
Change 6	8 December 1987	Change 13	30 September 1992				
Page No.	*Change No.	Page No.	Change No.	Page No.	Change No.	Page No.	Change No.
Title	0	10-44.1/10-44.2 blank ..	3	10-101	0	10-147	3
A - D	24	10-45 and 10-46	3	10-102	9	10-148	0
a/b blank	21	10-46.1/10-46.2 blank ..	7	10-103	0	10-149	6
i through ii	23	10-47 and 10-48	3	10-104	3	10-150	0
iii/iv blank	24	10-48.1/10-48.2 blank ..	3	10-105 and 10-106	9	10-151	2
v	8	10-49 and 10-50	3	10-107	0	10-152 - 10-153 deleted .	2
vi	9	10-50.1/10-50.2 blank ..	7	10-108	9	10-154	0
vii	21	10-51 and 10-52	3	10-109 and 10-110	3	10-155	6
viii	22	10-52.1/10-52.2 blank ..	7	10-111	2	10-156	9
10-1/10-2 blank	0	10-53	3	10-112	15	10-157	0
10-2.1	2	10-54 and 10-55	0	10-113 and 10-114	0	10-158	9
10-2.2	0	10-56 - 10-59	3	10-115 and 10-116	3	10-159	0
10-2.3	22	10-60 and 10-61	2	10-117	6	10-160	9
10-2.4 - 10-2.6	23	10-62	3	10-118	2	10-161	0
10-2.7/10-2.8 blank	22	10-62.1/10-62.2 blank ..	3	10-119	0	10-162	9
10-2.9	0	10-63 and 10-64	3	10-120	9	10-163	0
10-2.10	3	10-64.1/10-64.2 blank ..	3	10-121/10-122 blank ...	0	10-164	9
10-3	3	10-65 and 10-66	3	10-123	0	10-165 and 10-166	0
10-4	0	10-66.1/10-66.2 blank ..	9	10-124 - 10-126	22	10-167 and 10-168	9
10-5 blank	0	10-67 and 10-68	3	10-127 - 10-129	20	10-169	0
10-6 - 10-14	0	10-68.1/10-68.2 blank ..	3	10-130 and 10-131	22	10-170	6
10-15	7	10-69	3	10-132	6	10-171	0
10-16 - 10-28	0	10-70 and 10-71	0	10-133	0	10-172	9
10-29	7	10-72 - 10-75	3	10-134	6	10-173	0
10-30 - 10-34 blank	0	10-76 and 10-77	2	10-135	0	10-174	9
10-35	0	10-78	0	10-136	6	10-175 and 10-176	2
10-36 and 10-37	23	10-79	2	10-137	0	10-177/10-178 blank ...	6
10-38	15	10-80 through 10-95	23	10-138	6	10-179 and 10-182	22
10-39	17	10-96	15	10-139	0	10-183 blank/10-184 ...	22
10-40 and 10-41	2	10-97	23	10-140	6	10-185 - 10-190	22
10-42	23	10-98	3	10-141 and 10-142	0	10-191 blank/10-192 ...	22
10-43	2	10-99	6	10-143	6	10-193 and 10-194	22
10-44	3	10-100	15	10-144 - 10-146	0	11-1/11-2 blank	0

*Zero in this column indicates an original page.

Page No.	*Change No.	Page No.	Change No.	Page No.	Change No.	Page No.	Change No.
11-2.1	3	11-46	12	11-112 - 11-114	23	11-184	3
11-2.2	23	11-47 - 11-49	0	11-114.1 and 11-114.2	23	11-185 blank	0
11-2.3/11-2.4 blank	23	11-50 and 11-51	23	11-115 and 11-116	0	11-186	0
11-2.4.1	3	11-52	12	11-117	9	11-187	3
11-2.4.2	2	11-53 - 11-55	23	11-118	0	11-188	0
11-2.4.3 11-2.4.4	3	11-56	12	11-119	9	11-189/11-190 blank	2
11-2.4.4	23	11-57	23	11-120	0	11-191 - 11-195	0
11-2.5	23	11-58 and 11-59	2	11-121	2	11-196	6
11-2.6	9	11-60	0	11-122	0	11-197 - 11-201	0
11-2.7 and 11-2.8	23	11-61 blank	0	11-123	2	11-202 blank	0
11-2.9 - 11-2.10	0	11-62	0	11-124	9	11-203	0
11-3 - 11-5	0	11-63	6	11-125 and 11-126	0	11-204	14
11-6	6	11-64	0	11-127 and 11-128	9	11-205 - 11-208	0
11-7/11-8 blank	10	11-65	6	11-129 - 11-131	2	11-209	13
11-9	0	11-66	1	11-132.1 - 11-132.6	10	11-210	0
11-10	3	11-67	0	11-133 blank	10	11-211	13
11-11 blank	6	11-68	3	11-134	10	11-212	0
11-12 and 11-13	6	11-69	0	11-135	9	11-213	13
11-14	12	11-70	9	11-136	0	11-214	0
11-15	6	11-71 blank	0	11-137	10	11-215	13
11-16	0	11-72	0	11-138 - 11-140	0	11-216	0
11-17	6	11-73	6	11-140.1 blank	6	11-217	13
11-18 - 11-22	0	11-74	0	11-140.2	6	11-218	0
11-23	2	11-75	6	11-141	6	11-219	13
11-24	0	11-76 - 11-79	23	11-142 - 11-144	0	11-220	0
11-25	2	11-80	0	11-145	17	11-221	13
11-26 - 11-28	0	11-81/11-82 blank	9	11-146 - 11-148	0	11-222	14
11-29	2	11-83 blank	6	11-149	6	11-223 - 11-226	0
11-30 and 11-31	0	11-84 and 11-85	6	11-150	0	11-227/11-228 blank	13
11-32	2	11-86	0	11-151	6	11-229 - 11-231	0
11-33/11-34 blank	0	11-87	13	11-152	0	11-232	14
11-35	0	11-88 - 11-90	23	11-153	6	11-233	0
11-36	3	11-90.1 and 11-90.2	23	11-154	0	11-234 and 11-235	14
11-37	23	11-91 and 11-92	0	11-155	2	11-236 - 11-238 blank	0
11-38	7	11-93	2	11-156	0	12-1/12-2 blank	0
11-39 - 11-41	3	11-94	0	11-157	9	12-2.1 - 12-2.2	3
11-42	14	11-95	2	11-158 - 11-162	0	12-2.3 and 12-2.4	23
11-42.1	9	11-96	0	11-163	3	12-2.5 and 12-2.6 blank	0
11-42.2 - 11-42.8	3	11-97	2	11-164	0	12-2.7 and 12-2.8	0
11-42.9 blank	3	11-98	0	11-165	3	12-3 - 12-15 blank	0
11-42.10	3	11-99 and 11-100	2	11-166 - 11-170	0	12-16	0
11-42.11	10	11-101 and 11-102	0	11-171	3	12-17	12
11-42.12	23	11-103 and 11-104	2	11-172	0	12-18 - 12-32 blank	0
11-42.13	9	11-105	0	11-173	3	12-33 and 12-34	23
11-42.14	13	11-106	2	11-174 and 11-175	0	12-34.1/12-34.2 blank	23
11-42.15 and 11-42.16	9	11-107	6	11-176	6	12-35 blank	0
11-42.17	15	11-108	0	11-177	2	12-36 and 12-37	0
11-42.18 blank	15	11-109	2	11-178	0	12-38	23
11-43	9	11-110	0	11-179	2	12-38.1/12-38.2 blank	23
11-44 and 11-45	0	11-111	6	11-180 - 11-183	0	12-39	0

*Zero in this column indicates an original page.

Page No.	*Change No.	Page No.	Change No.	Page No.	Change No.	Page No.	Change No.
12-40	23	14-2.1	0	15-61 - 15-66 blank	8	16-14 - 16-16	23
12-40.1/12-40.2 blank	23	14-2.2	3	15-67 and 15-68	8	16-16.1/16-16.2 blank	9
12-41	0	14-2.3 - 14-2.6	0	15-69 - 15-71	23	16-17 and 16-18	9
12-42	23	14-3	3	15-72 - 15-79	8	16-19	23
12-43	0	14-4 - 14-8	0	15-80 and 15-81	10	16-20 - 16-30	0
12-44	23	14-9	9	15-82 - 15-86 blank	8	16-31	3
12-44.1/12-44.2 blank	23	14-10	0	15-87/15-88 blank	8	16-32 and 16-33	0
12-45	2	14-11	10	15-89 and 15-90	23	16-34 - 16-38	23
12-46 and 12-47	0	14-12 - 14-14	0	15-90.1/15-90.2 blank	23	16-39 - 16-41	0
12-48	23	14-15	10	15-91 - 15-94.2	23	16-42 and 16-43	6
12-48.1/12-48.2 blank	23	14-16 - 14-17	0	15-95 15-96.2	23	16-44	2
12-49 - 12-55	0	14-18	2	15-97 - 15-98.2	23	16-45 blank	0
12-56 - 12-58	23	14-19	0	15-99 and 15-100	23	16-46	0
12-59	12	14-20 and 14-21	6	15-101/15-102 blank	8	16-47	2
12-60	23	14-22 - 14-28	0	15-103 - 15-107	8	16-48	9
12-61	0	14-29	6	15-108 blank	8	16-49	0
12-62	23	14-30 - 14-33 blank	0	15-109	8	16-50	10
12-63	0	14-34 - 14-38 blank	0	15-110 and 15-111	23	16-51	2
12-64	23	15-1/15-2 blank	0	15-112 - 15-117	8	16-52	0
12-65	0	15-3 - 15-6 blank	8	15-118 - 15-127	23	16-53	9
12-66	23	15-7	8	5-128	8	16-54 and 16-55	23
12-67	0	15-8 - 15-10.2	23	5-129	23	16-56	0
12-68	23	15-11 - 15-12	23	15-130	8	16-57 blank	0
12-69/12-70 blank	0	15-12.1/15-12.2 blank	23	15-131	23	16-58	0
12-71 - 12-80	0	15-13	23	15-132	10	16-59	2
12-81 blank	6	15-14 and 15-15	8	15-133	17	16-60 and 16-61	23
12-82	6	15-16 - 15-17/15-18 blank	23	15-134	8	16-62 and 16-63	0
12-83/12-84 blank	0	15-19/15-20 blank	8	15-135 and 15-136	23	16-64 and 16-65	23
13-1/13-2 blank	0	15-21	8	15-137/15-138 blank	8	16-66	0
13-2.1 - 13-2.3	23	15-22 and 15-23	23	15-139 - 15-142	8	16-67	9
13-2.4	3	15-24 - 15-27	8	15-143/15-144 blank	15	16-68	2
13-2.5/13-2.6 blank	0	15-28	23	16-1/16-2 blank	3	16-69 blank	9
13-2.7	0	15-29	8	16-2.1-16-2.2.1/16-2.2.2 blank	24	16-70 and 16-71	9
13-2.8	23	15-30 and 15-31	23	16-2.3 and 16-2.4	24	16-72 - 16-74 blank	0
13-2.8.1/13-2.8.2 blank	9	15-32 and 15-33	8	16-2.5	23	16-75	0
13-3	23	15-34	10	16-2.6	3	16-76	17
13-4 and 13-5	0	15-35	23	16-2.6.1/16-2.6.2 blank	18	16-77 blank	12
13-6 and 13-7	23	15-36	10	16-2.6.3/16-2.6.4 blank	24	16-78	12
13-8	0	15-37	23	16-2.7	0	16-79	0
13-9 and 13-10	6	15-38	10	16-2.8	9	16-80	12
13-11 blank	0	15-39/15-40 blank	10	16-2.9 and 16-2.10	23	16-81	2
13-12	0	15-41 and 15-42	8	16-3 - 16-5	23	16-82	12
13-13	9	15-43 - 15-45	23	16-6	0	16-83	10
13-14 - 13-22	0	15-46	8	16-7	9	16-84	0
13-23	6	15-47/15-48 blank	10	16-8	0	16-85 blank	12
13-24 - 13-27	0	15-49/15-50 blank	8	16-9 blank	9	16-86	12
13-28	23	15-51 - 15-57	8	16-10	23	16-87	6
13-29 blank	0	15-58	23	16-11	10	16-88	12
13-30 - 13-32	0	15-59	8	16-12	23	16-89	0
14-1/14-2 blank	0	15-60	23	16-13	9	16-90	12

*Zero in this column indicates an original page.

Page No.	*Change No.	Page No.	Change No.	Page No.	Change No.	Page No.	Change No.
16-91	0	16-106	12	17-12 - 17-15 blank	3	18-61 - 18-96 blank	19
16-92	12	16-107/16-108 blank	3	17-16 - 17-20 blank	3	18-97 - 18-142	21
16-93	2	16-109 - 16-142	16	18-1/18-2 blank	18	Index-1 - Index-2	23
16-94	12	16-143 - 16-147 blank	18	18-3	21	Index-3 - Index-4	24
16-95	2	16-148 - 16-180 blank	18	18-4	18	Index-5 - Index-10 blank	23
16-96	12	16-181 - 16-226 blank	24	18-4.1 and 18-4.2	21		
16-97	2	17-1/17-2 blank	0	18-5 and 18-6	19		
16-98	12	17-2.1	2	18-6A/18-B blank	21		
16-99	2	17-2.2	3	18-6.1 and 18-6.2	19		
16-100	12	17-2.3/17-2.4 blank	0	18-7	18		
16-101 - 16-103	3	17-2.5	0	18-8	21		
16-104	12	17-2.6	3	18-9 - 18-60 blank	18		
16-105	3	17-3 - 17-11 blank	3				

*Zero in this column indicates an original page.

Aviation Unit and Aviation Intermediate
Troubleshooting Manual
CH-47D HELICOPTER

REPORTING OF ERRORS AND RECOMMENDING IMPROVEMENTS

You can help improve this manual. If you find any mistakes or if you know of a way to improve the procedures, please let us know. Mail your letter, DA Form 2028 (Recommended Changes to Publications and Blank Forms), or DA Form 2028-2 located in the back of this manual direct to: Commander, U.S. Army Aviation and Missile Command, ATTN: AMSAM-MMC-LS-LP, Redstone Arsenal, AL 35898-5230. A reply will be furnished to you. You may also send your comments electronically to our e-mail address: ls-lp@redstone.army.mil or by fax 205-842-6546/DSN 788-6546. Instructions for sending an electronic 2028 may be found at the back of this manual immediately preceding the hard copy 2028.

TABLE OF CONTENTS

	<i>Page</i>		<i>Page</i>
HOW TO USE THIS MANUAL	v	CHAPTER 4. Powerplant Systems Troubleshooting (Continued)	
CHAPTER 1. Troubleshooting Terminology	1-1	4-8. Engine Performance Check (With 74)	4-195
1-1. Failure Symptoms List.....	1-3	4-9. Engine Low Oil Level Warning System (With 74).....	4-213
1-2. Electrical Symbols	1-16	4-10. Engine Start and Ignition System (With 74).....	4-221
1-2.1. Mechanical Symbols	1-17	4-11. Gas Producer Control System (With 74).....	4-247
1-3. Station, Water, and Butt Lines	1-18	4-12. Full Authority Digital Engine Control (FADEC) (With 74).....	4-255
1-4. 300 Series Connector Plug and Receptacle Wiring Data.....	1-19	4-13. Engine Accessory Gearbox Chip Detectors (With 74).....	4-313
1-5. Terminal Board Wiring Data.....	1-65	CHAPTER 5. Rotor Blade Tracking and Balancing System Troubleshooting	5-1
1-6. Ground Devices Wiring Data	1-79	Chapter Overview.....	5-2.1
1-7. Glossary.....	1-87	5-1. Centrifugal Droop Stop.....	5-2.5
CHAPTER 2. Vibration Analysis and Dynamic Absorber System Troubleshooting	2-1	5-2. Rotor Blade Tracking and Balancing System	5-5
Chapter Overview.....	2-2.1	CHAPTER 6. Drive System Troubleshooting	6-1
2-1. Vibration Analysis	2-5	Chapter Overview.....	6-2.1
2-2. Dynamic Absorber System	2-19	6-1. Transmission Lubrication Systems.....	6-2.7
CHAPTER 3. Alighting Gear	3-1	6-2. Transmission Chip Detectors and Debris Screen.....	6-25
Chapter Overview.....	3-2	6-3. Transmission Chip Detector Fuzz Burn Off Module	6-85
3-1. Proximity Switch.....	3-3	CHAPTER 7. Hydraulic "AIRFRAME" Systems Troubleshooting	7-1
CHAPTER 4. Powerplant Systems Troubleshooting	4-1	Chapter Overview.....	7-2.1
Chapter Overview.....	4-2.1	7-1. Flight Control Hydraulic System.....	7-2.11
4-1. Engine Performance Check (Without 74).....	4-2.9	7-2. Utility Hydraulic System.....	7-71
4-2. Engine Anti-Icing System (Without 74).....	4-31	7-3. Cargo Ramp and Door	7-119
4-3. Engine Low Oil Level Warning System (Without 74).....	4-43	7-4. Swivel Locks System	7-139
4-4. Engine Start and Ignition System (Without 74).....	4-51	7-5. Power Steering System.....	7-153
4-5. Gas Producer Control System (N1) (Without 74).....	4-91	7-6. Wheel Brakes System.....	7-175
4-6. Power Turbine Control System (N2) (Without 74).....	4-115	7-7. Engine Hydraulic Starting System.....	7-199
4-7. Engine Accessory Gearbox Chip Detectors (Without 74).....	4-177	7-8. APU Hydraulic Starting System	7-207
		7-9. Integrated Lower Control Actuator (ILCA).....	7-221

	<i>Page</i>
CHAPTER 7. Hydraulic "AIRFRAME" Systems Troubleshooting (Continued)	
7-10. Hydraulic Hand Pump	7-235
INDEX	Index-1
CHAPTER 8. Instrument Systems Troubleshooting	8-1
Chapter Overview	8-2.1
8-1. Pitot Static System	8-2.11
8-2. Gas Producer Tachometer System	8-29
8-3. Engine Oil Pressure Indicating System	8-43
8-4. Engine Oil Temperature Indicating System	8-61
8-5. Power Turbine Inlet Temperature System	8-73
8-6. Torque Indicating System	8-101
8-7. Hydraulic Pressure Indicating System	8-121
8-8. Hydraulic Oil Temperature Indicating System	8-135
8-9. Transmission Oil Pressure Indicating and Warning System	8-149
8-10. Transmission Oil Temperature Indicating and Warning System	8-213
8-11. Fuel Quantity Indicating System	8-259
8-12. Cruise Guide Indicating System	8-295
8-13. Turn and Slip Indicators	8-309
8-14. Maintenance Panel Power Distribution	8-319
8-15. Rotor Tachometer	8-333
8-16. Engine Fuel Flow Indicating System	8-343
CHAPTER 9. Electrical System Troubleshooting	9-1
Chapter Overview	9-2.1
9-1. DC Power System	9-2.17
9-2. AC Power System	9-53
9-3. Position Lights	9-99
9-4. Landing Lights (Search Lights)	9-107
9-5. Formation Lights	9-139
9-6. Anticollision Lights	9-151
9-7. Forward Transmission Oil Level Check Light	9-159
9-8. Pilot Flight Instrument Panel Lights	9-167
9-9. Center Flight Instrument Panel Lights	9-179
9-10. Copilot Flight Instrument Panel Lights	9-187
9-11. Overhead Panel Lights	9-199
9-12. Console Panel Lights	9-213
9-13. Secondary Cockpit Light	9-229
9-14. Cockpit Dome and Utility Lights	9-247

CHAPTER 9. Electrical System Troubleshooting (Continued)	
9-15. Cabin and Ramp Lights	9-259
9-16. Troop Warning System	9-277
9-17. Utility Receptacles	9-303
9-18. Master Caution Lights	9-321
9-19. Avionics Cooling Fan	9-341
9-20. Anticollision Light (AVIM)	9-351
9-21. Master Caution Panel (AVIM)	9-359
9-22. Clock	9-365
9-23. Cargo Hook Lights	9-375
INDEX	Index-1
CHAPTER 10. Fuel System Troubleshooting	10-1
Chapter Overview	10-2.1
10-1. Engine Fuel Shutoff and Crossfeed Valves	10-2.9
10-2. Fuel Boost Pumps	10-35
10-3. Single Point Pressure Refueling System	10-123
10-4. Extended Range Fuel System (ERFS II) (With 84)	10-179
CHAPTER 11. Flight Control Systems Troubleshooting	11-1
Chapter Overview	11-2.1
11-1. Flight Control System	11-2.9
11-2. Artificial Feel - Magnetic Brakes	11-9
11-3. AFCS	11-35
11-4. AFCS Control Panel	11-191
11-5. AFCS Computer	11-203
11-6. Cockpit Control Drive Actuator (CCDA)	11-229
CHAPTER 12. Utility System Troubleshooting	12-1
Chapter Overview	12-2.1
12-1. Windshield Anti-Icing System	12-2.7
12-2. Fire Detection System	12-29
12-3. Fire Extinguisher System	12-53
12-4. Windshield Wipers	12-71
CHAPTER 13. Environmental Control System Troubleshooting	13-1
Chapter Overview	13-2.1
13-1. Heating and Ventilating System	13-2.7
CHAPTER 14. Hoist and Winch Troubleshooting	14-1
Chapter Overview	14-2.1
14-1. Cargo/Rescue Winch System	14-2.5

	<i>Page</i>
CHAPTER 15. Auxiliary Power Unit Troubleshooting	15-1
Chapter Overview	15-3
15-1. APU to Airframe Interface	15-5
15-2. APU Electrical System	15-19
15-3. APU Fuel System	15-49
15-4. APU Hydraulic System	15-65
15-5. APU/Engine Hydraulic Starter System	15-89
15-6. APU Microprocessor Electronic Sequence Unit (ESU)	15-103
15-7. APU Tester	15-139
 CHAPTER 16. Mission Equipment Troubleshooting	 16-1
Chapter Overview	16-2.1
16-1. External Cargo Hook System	16-2.7
16-2. Flare Dispenser System	16-75

	<i>Page</i>
 CHAPTER 16. Mission Equipment Troubleshooting (Continued)	
16-3. Engine Air Particle Separator System	16-109
16-4. Heads Up Display System	16-143
16-5. Countermeasures Dispenser System	16-181
 CHAPTER 17. Emergency Equipment Troubleshooting	 17-1
Chapter Overview	17-2.1
17-1. Emergency Exit Lights	17-2.5
 CHAPTER 18. Installed Avionics Equipment	 18-1
Chapter Overview	18-3
18-1. Global Positioning System	18-7
18-2. Audio Voice Warning System (Radar Altimeter)	18-47
18-3. Doppler/GPS Navigation System	18-61
18-4. HF Liaison Facility	18-97
 INDEX	 Index-1

HOW TO USE THIS MANUAL (TM 55-1520-240-1)

This manual has 17 Chapters that have instructions for troubleshooting 72 CH-47 Helicopter Systems.

Chapter 1 has:

- The Complete List of Troubleshooting Symptoms you will find in this manual. This list outlines each chapter by system and symptom.
- Complete wiring for 300 Series Connectors and Receptacles, Terminal Boards, and Ground Devices.

Chapters 2 thru 17 have sets of troubleshooting instructions that include:

- **A Chapter outline** of all systems and symptoms found in the beginning of each Chapter.
- **Connector part numbers and pin patterns** for each connector and receptacle in systems contained in chapter. Also included are **relay termination views** and **ground termination types** and **location**.
- **System Component Diagrams**
- **System Block Diagrams**
- **System Schematics, Ladder Schematics and Wiring Diagrams**
- **Fuel Piping Diagrams**
- **Hydraulic Piping Diagrams**
- **Tables**
- **Visual Checks** with locator figures and step by step procedures.
- **Operational Checks** with locator figures and step by step procedures.
- **Fault Isolation Procedures** with locator figures and troubleshooting logic for specific system faults.

HOW TO FIND WHAT YOU NEED

Maintenance -Refer to TM 55-1520-240-23.

Troubleshooting -Use the index in Chapter 1 or in the beginning of each chapter. This is where you will find the system troubleshooting procedures (visual checks, operational checks and fault isolation procedures).

1. The troubleshooting procedures are listed under the name of the system that the component or system belongs to.
2. Each system has a number:
Example:

System No.	System
9-15	Cabin and Ramp Lights
3. Each item in your set of troubleshooting instructions has a task number. The system number is prefixed to each of the item task numbers.
Example:

System No.	System Symptom	Task No.
9-15	Cabin and Ramp Lights	
	Wiring Diagram	9-15.1
	Visual Check	9-15.2
	Operational Check	9-15.3
	Cabin and Ramp Circuit Breaker Does not Stay Closed	9-15.4

TASK PREPARATION

Each Troubleshooting procedure begins with INITIAL SETUP information. Read it carefully before starting. It tells you what you need and what you have to know before you begin the job.

1. **Applicable Configurations.** Tells you what configurations or effectivity the task applies to.
2. **Tools.** If any tools from your tool kit are needed, just the kit is listed. Tools needed that are not in the kit are called for by name. Special ground support tools, containers, and test equipment are listed by tool number (Txx). Find these items in TM 55-1520-240-23.
3. **Materials.** Materials needed are listed by expendable number (EXX). Find these Items in TM 55-1520-240-23.
4. **Parts.** New parts required, such as gaskets, packings, and washers, are listed by name only. If parts are not needed, you will not see this heading.
5. **Personnel Required.** Each MOS needed to do the task is listed. When more than one of any MOS is needed, the number is shown in parentheses.
6. **References.** Lists references such as TM 55-1520-240-23. These references will provide where information can be found when you need to repair or replace a part or component. When more than one reference is listed, the Fault Isolation Procedure blocks will contain a refer to statement for all references other than TM 55-1520-240-23.
7. **Equipment Condition.** Procedures which must be done before starting the task are listed and task or TM number is given. Tasks that are not indented under a TM manual can be found in this manual. Refer to the TM manual listed above the indented tasks.
8. **General Safety Instructions.** These are safety precautions that must be observed throughout task. Warnings Include basic first aid instructions.
9. **Locator Figure.** The area of the helicopter where the task will be performed is shown, with components to be worked on called out.

TASK PERFORMANCE

1. Visual Checks are performed to determine if the cause of the system fault is visually apparent.
2. Operational Checks are performed step by step on the system to determine the system fault. Continue the operational check TASK until the symptom is confirmed in the RESULT column.
3. Fault Isolation Procedures are performed to identify the specific trouble in the system. Start with the first block. Read it through and answer the question, The questions will always have a YES or NO answer. If you answer the question YES, follow the direction of the YES arrow to the next block. If you answer the question NO, follow the direction of the NO arrow to the next block. Continue troubleshooting until the symptom cause is identified.
4. Use the integrated schematic during troubleshooting for a view of system component connections and system interfaces.
5. Use the wiring diagram when the troubleshooting instructions require wire tests to isolate the symptom cause.

TM 55-1520-240-T-3

6. Before starting, read the entire task. Familiarize yourself with the entire procedure before beginning the task.
7. As you read, pay attention to **WARNINGS, CAUTIONS,** and **NOTES.**
8. **When the word INSPECT** is in your procedures, an inspector must ok the completed step(s).
9. Major steps and key words are printed in boldface for experienced repairers.
10. A glossary is on page 1-87. It lists the abbreviations, special words and terms used in this manual and gives their meaning.
11. When a special tool is used or a common tool is used in an unusual way, the use of the tool will be shown.
12. When a block states, "Repair or replace wire as required.", refer to TM 55-1500-323-24 for recommended maintenance practices.
13. Voltages specified in blocks are nominal values unless a range is given. These nominal values and their acceptable ranges are as follows:

Nominal voltage	Range
28 VDC	24 to 30
26 VAC	24 to 28
24 VDCV (Battery)	20 to 74
5 VAC	4 to 6
115 VAC	110 to 120

14. in the event of the necessity to add or replace electrical wiring, the colors of wire received from supply may not be the same as the original wire colors. Use wire numbers only for identification of wires. Tag or identify wires by proper number when disconnecting or replacing.

AIRCRAFT MODIFICATION (ECP/MWO) RETROFIT INFORMATION

Throughout this manual, black squares containing white numerals are used to distinguish information relating to helicopters modified by an MWO or ECP. Refer to Helicopter Configuration Legend on the following pages for specific modification and effectivities relating to each numeral. A list of delivered helicopters serial numbers is included with the legend.

information pertaining only to unmodified helicopters is identified by the appropriate effectivity symbol preceded by WITHOUT. For example, WITHOUT 4 indicates that the information that follows is applicable only to helicopters not modified by ECP DO18. Information pertaining only to helicopters that have been modified by ECP DO18 is preceded by WITH 4. . All information not preceded by an effectivity symbol is common to all helicopters.

The following helicopter Designation Legend pages are solely for user convenience. They have no official status.

DELIVERED HELICOPTER SERIAL NUMBERS

81-23382	82-23762	83-24102	84-24152	85-24322
through	through	through	through	through
81-23389	82-23780	83-24125	84-24187	85-24336

HELICOPTER CONFIGURATION LEGEND

CODE	ECP/MWO NO.	TITLE	EFFECTIVITY	
			PRODUCTION (Serial Number)	RETROFIT
1	ECP D003RI	Improved Synch Shaft Vibration Mount	84-24108 and on	Attrition
2	ECP DO10R2C1	Fuel Cell Manifold Control Bracket	82-23389 and on	Attrition
3	ECP DO08	Rotor Hub Protective Cover Enlargement	85-24322 and on	Attrition
4	ECP D018R2	Composite Fuel Pods	84-24162 and on	Attrition
5	ECP DO06	Removable Support Structure Pylon Hyd. Module	81-23385 and on	By Kit all D
6	ECP DO37R2	Shorter 114C1014 Yaw Connecting Link	85-24322 and on	Attrition
7	ECP DO34	Pilot and Co-Pilot Seat Armor	81-23386 and on	Attrition
8	ECP DO42	Redesign Link Assy for Increased Parked Blade Loads	83-24105 and on	Attrition
9	ECP DO48C1	Flare Dispenser Blanket Mod and Stowage Provision	83-24107 and on	None
10	ECP DO61R	Floor Former/Fuselage Bilge Paint (Special paint for 14 aircraft)	83-24107 and on (Interior) 83-24105 thru 83-24118 (Exterior)	None
11	ECP DO65	Second Source 114PS494 Fuel Shutoff Valve (Motorized)	82-23776 and on	Attrition
12	ECP DO71	2-Inch Dia. Fuel Breakaway Fittings	83-24110 and on	Attrition
13	ECP DO74C1	Install Steel Control Rods Aft Pylon	83-24103 and on	81-23381 thru 83-24102 by Tech Bulletin
14	ECP DO15C2	Install Bubble Windows	85-24322 and on	Attrition
15	ECP DO51C1	Rainshield Redesign	84-24158 and on	Attrition
16	ECP DO75	Heater Modification	85-24322 and on	Attrition
17	ECP DO27R1C1	Night Vision Goggles (NVG)	85-24322 and on	MWO
18	ECP DO36R1	Improved N1 System	85-24322 and on	Attrition
19	ECP DO69R4	Ferry Fuel Provisions	85-24322 and on	MWO
20	ECP DO64R1	Aft Pylon Work Platform Redesign	85-24322 and on	Attrition
21	ECP DO29C1	ILCA Actuator and Manifold Seal Change	85-24322 and on	Attrition
22	ECP DO60R1	Ramp Skin and Ramp End Former	85-24322 and on	Attrition
23	ECP DO01R1	Improved N2 Control Box	84-24156 and on	Attrition
24	ECP DO56R2	Redesign Droop Stop Arm to Increase Clearance With Shroud; Modify Spring Limiter	85-24322 and on	Contractor Kit
25	ECP DO81R2	Ground Contact Annunciator	87-0069 and on	MWO

HELICOPTER CONFIGURATION LEGEND (Continued)

CODE	ECP/MWO NO.	TITLE	EFFECTIVITY	
			PRODUCTION (Serial Number)	RETROFIT
26	ECP D118C1	Improved Heat Resistance of Flight Control System Bellcranks and Connecting Rods	85-24353 and on	MWO
27	ECP D054R1	Combining Transmission Support Fitting Redesign	84-24154 and on	Attrition
28	ECP D126C1	Accumulator, APU/Flight Control Modules	86-1635 and on	Attrition
29	ECP DO85C1	Reduced Length Servo-Cylinder Safety Blocks	GSE	MWO
30	ECP 712R7	Portable Calculator and Hardware for Vibrex	OBSOLETE	- - - - -
31	ECP D108	Aft Transmission Torque Reactor Improvement	GSE	MWO
32	ECP D111	Deletion of KY-28 Secure Voice Control Panel	87-0069 and on	AVSCOM MSG.
33	ECP D133	UH60/CH47D Common ESU	86-1650 and on	MWO
34	ECP D122	Change Droop Stop Shroud From Installed to Flyaway Equipment	85-24361 and on	N/A
35	ECP D016R1	Single Handle Cargo Hook Release System	88-0079 and on	MWO
36	ECP D113	Hook Release Button Ring Guard on Cyclic Grip	88-0085 and on	MWO
37	ECP D115	Transmission and Engine Chip Burn-Off System	89-0139 and on	MWO
38	ECP D154R1 (Phase 1)	Installation of Stainless Steel Flight Control Connecting Links	88-0091 and on	MWO
39	ECP DO69R4	Ramp Extension/Center Skid Pad Modification for Compatibility With HICHS	90-0180 and on	Attrition
40	ECP D121R2	Fine Mesh Inlet Screen	88-0095 and on	Retrofit
41	ECP D105R1	Shotpeen Horizontal Hinge Pins	88-0107 and on	MWO
42	ECP D135	Improved Rotor Blade Grounding Strap	88-0103 and on	MWO
43	ECP DO89	Delete Engine Anti-Ice System	87-0077 and on	MWO
44	ECP D101	Engine Oil Pressure Transmitter Vibration Absorber	90-0180 and on	MWO
45	ECP D092R1	Elastomeric Lag Damper and Pitch Link Bearings	90-0180 and on	MWO
46	ECP D114C2	Upper and Middle Drive Scissors Positive Locking Bolts	90-0180 and on	MWO
47	ECP D095R1	Airframe Structural Improvements	90-0180 and on	Attrition
48	ECP D173	Combining Transmission Sync Shaft Shielding Baffle	88-0099 and on	MWO
49	ECP D131R1	Transmission Drip Pan Material Change	90-0214 and on	Attrition

HELICOPTER CONFIGURATION LEGEND (Continued)

CODE ECP/MWO NO.	TITLE	EFFECTIVITY	
		PRODUCTION (Serial Number)	RETROFIT
50	ECP D145R1C1	Boft/Bushing Assembly Improvements	90-0180 and on MWO 1-1520-240-50-37
51	ECP D157R1	One Piece Engine Drive Shaft	90-0180 and on MWO 55-1520-240-50-43
52	ECP D190R1	Improved Clamshell Door Latch	92-0282 and on MWO 1-1520-240-50-62
53	ECP D164	Incorporation of Dome Light Positive Locking Lever Switch	91-0252 and on MWO 55-1520-240-50-50
54	ECP D154R1 (Phase 2)	Control System Hardening and Smoke Containment	81-23381 thru 89-0177 MWO 1-1520-250-50-40
55	ECP D185R1	Separate Fuel Control Relay Box Ground Connections	90-0202 and on MWO 1-1520-240-50-58
56	ECP D183	Helicopter Internal Cargo Handling System (HICHS) Ramp Centerline Attachment	81-23381 thru 91-0227 MWO 1-1520-240-50-59
57	ECP D175	Engine Aft Mount Adjustable Link	81-23381 thru 92-0302 MWO 1-1520-240-50-60
58	ECP D145R2	Improved Bolt/Bushing Connection	N/A MWO 1-1520-240-50-69
59	ECP D198A1	Polyurethane Paint for CH-47D Aircraft	- Attrition
60	ECP A098	Heads Up Display System (HUD) AN/AVS-7	81-23381 thru 91-0271 MWO 1-1520-240-50-56
61	ECP A0027	Global Positioning System (GPS) AN/ASN-149(V)1	81-23381 thru 92-0302 MWO 1-1520-240-50-68
62	ECP AEEMH- 03009	Altitude Voice Warning System Radar Altimeter, AN/APN-209(V)	81-23381 thru 93-0934 MWO 1-1520-240-50-61
63	ECP D200 (Phase 2)	Replace Lower Pitch Link Elastomeric Bearing	90-0180 and on MWO 1-1520-240-50-64 and MWO 1-1520-240-50-63
64	ECP D194R1	Stainless Steel Bellcranks in Combining Transmission Area	81-23381 and on MWO 1-1520-240-50-65

HELICOPTER CONFIGURATION LEGEND (Continued)

CODE ECP/MWO NO.	TITLE	EFFECTIVITY	
		PRODUCTION (Serial Number)	RETROFIT
65	ECP D168R1	Cockpit Remote Emergency Ramp Extension System	81-23381 thru 92-0309 MWO 1-1520-240-50-48
66	ECP D199	Non-Metallic Spline Adapters for Combining Transmission Cooling Fan Drive Shaft	76-18479 and 81-23381 thru 93-00934 MWO 1-1520-240-50-67
67	ECP D214R1	Aft Position Lights Switch	76-18479 and 81-23381 thru 93-00934 MWO 1-1520-240-50-75
68	ECP D216	Pressure Refueling Vacuum Relief Valve	76-18479 and 81-23381 thru 93-00934 MWO 1-1520-240-50-81
69	ECP D215	NVG Bezel	76-18479 and 81-23381 thru 93-00934 MWO 1-1520-240-50-71
70	ECP D210R1	Easily Replaceable Cabin Escape Hatch	76-18479 and 81-23381 thru 93-00934 TB 1-1520-240-30-02
71	ECP END HO30015	Installation of AN/ASN-128B Doppler GPS Navigation System	76-18479 and on MWO 1-1520-240-50-73
72	ECP D209	Installation of Radar Altimeter in Center Hook Compartment	76-18479 and 81-23381 thru 93-00934 MWO 1-1520-240-50-72
73	ECP EJCH 007016	Installation of AN/ARC-220 and TSEC/KY-100 HF Liaison Facility	81-23381 thru 93-00934 MWO 1-1520-240-50-74
74	ECP D218	714/FADEC	76-18479 and 81-23381 thru 93-00934 MWO 1-1520-240-50-83
82	ECP D230	ERFS II Wiring	81-23385 and on MWO 1-1520-240-50-84

CHAPTER 10

FUEL SYSTEMS TROUBLESHOOTING

CHAPTER 10
 FUEL SYSTEMS TROUBLESHOOTING
 CHAPTER OVERVIEW

Chapter 10 contains procedures for Fuel Systems troubleshooting. Each fuel system and failure symptom is listed below. Included in this chapter are locations and views of all electrical connectors, receptacles, relays, and ground connections for Fuel System,
 Refer to TM 55-1520-240-23 for required Fuel System maintenance procedures.

SYSTEM	PARA
ENGINE FUEL SHUTOFF AND CROSS-FEED VALVES	10-1
FUEL BOOST PUMPS	10-2
SINGLE POINT PRESSURE REFUELING	10-3

FAILURE SYMPTOM LIST
 ENGINE FUEL SHUTOFF AND CROSSFEED VALVES

SYMPTOM	TASK
CROSSFEED FUEL VALVE HANDLE IS NOT AT CLSD WITH CROSSFEED FUEL VALVES SWITCH AT CLOSE	10-1.4
CROSSFEED FUEL VALVE HANDLE IS NOT AT OPEN WITH CROSSFEED VALVES SWITCH AT OPEN	10-1.4
CROSSFEED FUEL VALVE LIGHT DOES NOT COME ON, VALVE OPERATION NORMAL	10-1.4
ENGINE FUEL SHUTOFF CIRCUIT BREAKER DOES NOT STAY CLOSED	10-1.4

SYMPTOM	TASK
ENGINE FUEL VALVE HANDLE IS NOT AT OPEN WITH FIRE HANDLE IN	10-1.4
ENGINE FUEL VALVE LIGHT DOES NOT COME ON, VALVE OPERATION NORMAL	10-1.4
ENGINE FUEL VALVE HANDLE IS NOT AT CLSD WITH FIRE HANDLE PULLED	10-1.4
FUEL XFEED CONT CIRCUIT BREAKER DOES NOT STAY CLOSED	10-1.4
LEFT CROSSFEED FUEL VALVE LIGHT DOES NOT COME ON DURING PRESS-TO-TEST	10-1.4

SYMPTOM	TASK
NO. 1 ENGINE FUEL VALVE LIGHT DOES NOT COME ON DURING PRESS-TO-TEST	10-1.4
NO.2 ENGINE FUEL VALVE LIGHT DOES NOT COME ON DURING PRESS-TO-TEST	10-1.4
RIGHT CROSSFEED FUEL VALVE LIGHT DOES NOT COME ON DURING PRESS-TO-TEST	10-1.4

GO TO NEXT PAGE

CHAPTER 10
 FUEL SYSTEMS TROUBLESHOOTING
 CHAPTER OVERVIEW
 FAILURE SYMPTOM LIST (Continued)

FUEL BOOST PUMPS

SYMPTOM	TASK	SYMPTOM	TASK	SYMPTOM	TASK
LH FUEL PUMP AUX AFT CIRCUIT BREAKER WILL NOT STAY CLOSED	10-2.3	L FUEL PRESS CAPSULE DOES NOT GO OUT WHEN LEFT SIDE MAIN FWD FUEL PUMP SWITCH IS SET TO ON	10-2.3	RH FUEL PUMP CONT AUX AFT CIRCUIT BREAKER WILL NOT STAY CLOSED	10-2.3
LH FUEL PUMPS AUX FWD CIRCUIT BREAKER WILL NOT STAY CLOSED	10-2.3	L OR R FUEL PRESS CAPSULE IS NOT ON	10-2.3	RH FUEL PUMP CONT AUX FWD CIRCUIT BREAKER WILL NOT STAY CLOSED	10-2.3
LH FUEL PUMP CONT AUX AFT CIRCUIT BREAKER WILL NOT STAY CLOSED	10-2.3	LEFT OR RIGHT SIDE AUX PRESS LIGHT DOES COME ON WHEN PRESSED TO TEST	10-2.3	RH FUEL PUMPS AUX FWD CIRCUIT BREAKER WILL NOT STAY CLOSED	10-2.3
LH FUEL PUMPS CONT AUX FWD CIRCUIT BREAKER WILL NOT STAY CLOSED	10-2.3	LEFT SIDE AUX PRESS LIGHT COMES ON WHEN LEFT SIDE AUX AFT FUEL PUMP SWITCH IS SET TO ON	10-2.3	RH FUEL PUMPS MAIN AFT CIRCUIT BREAKER WILL NOT STAY CLOSED	10-2.3
LH FUEL PUMP CONT MAIN AFT CIRCUIT BREAKER WILL NOT STAY CLOSED	10-2.3	LEFT SIDE AUX PRESS LIGHT COMES ON WHEN LEFT SIDE AUX FWD FUEL PUMP SWITCH IS SET TO ON	10-2.3	RH FUEL PUMPS MAIN FWD CIRCUIT BREAKER WILL NOT STAY CLOSED	10-2.3
LH FUEL PUMP CONT MAIN FWD CIRCUIT BREAKER WILL NOT STAY CLOSED	10-2.3	R FUEL PRESS CAPSULE DOES NOT GO OUT WHEN RIGHT SIDE MAIN AFT FUEL PUMP SWITCH IS SET TO ON	10-2.3	RH FUEL PUMP CONT MAIN AFT CIRCUIT BREAKER WILL NOT STAY CLOSED	10-2.3
LH FUEL PUMPS MAIN AFT CIRCUIT BREAKER WILL NOT STAY CLOSED	10-2.3	R FUEL PRESS CAPSULE DOES NOT GO OUT WHEN RIGHT SIDE MAIN FWD FUEL PUMP SWITCH IS SET TO ON	10-2.3	RH FUEL PUMP CONT MAIN FWD CIRCUIT BREAKER WILL NOT STAY CLOSED	10-2.3
LH FUEL PUMPS MAIN FWD CIRCUIT BREAKER WILL NOT STAY CLOSED	10-2.3	RH FUEL PUMPS AUX AFT CIRCUIT BREAKER WILL NOT STAY CLOSED	10-2.3	RIGHT SIDE AUX PRESS LIGHT COMES ON WHEN RIGHT SIDE AUX AFT FUEL PUMP SWITCH IS SET TO ON	10-2.3
L FUEL PRESS CAPSULE DOES NOT GO OUT WHEN LEFT SIDE MAIN AFT FUEL PUMP SWITCH IS SET TO ON	10-2.3			RIGHT SIDE AUX PRESS LIGHT COMES ON WHEN RIGHT SIDE AUX FWD FUEL PUMP SWITCH IS SET TO ON	10-2.3

FAILURE SYMPTOM LIST (Continued).

SINGLE POINT PRESSURE REFUELING

SYMPTOM	TASK
FUEL DOES NOT STOP FLOWING WITHIN 4 SECONDS WITH ALL TEST SWITCH AT PRI OFF	10-3.4
FUEL DOES NOT STOP FLOWING WITHIN 4 SECONDS WITH ALL TEST SWITCH AT SEC OFF	10-3.4
FUEL REFUEL CIRCUIT BREAKER WILL NOT STAY CLOSED	10-3.4

SYMPTOM	TASK
LH OR RH REFUEL VALVE POSN LIGHT DOES NOT COME ON OR COMES ON AND STAYS ON	10-3.4
LH OR RH REFUEL VALVE POSN LIGHT DOES NOT COME ON WHEN PRESSED	10-3.4
LH OR RH REFUEL VALVE POSN LIGHT IS ON	10-3.4

SYMPTOM	TASK
PWR LIGHT DOES NOT COME ON	10-3.4
REFUEL PANEL FUEL QUANTITY INDICATOR DOES NOT INDICATE FUEL LEVEL	10-3.4
REFUEL PANEL LIGHT DOES NOT COME ON	10-3.4
TANK WILL NOT ACCEPT FUEL WHILE PRESSURE REFUELING	10-3.4

EXTENDED RANGE FUEL SYSTEM (ERFS II) (WITH 32)

SYMPTOM	TASK
ERFS II REFUEL VALVE HANDLE NOT AT CLSD WHEN CONTROL PANEL REFUEL VALVE SWITCH SET TO CLOSE	10-4.4
ERFS II REFUEL VALVE HANDLE NOT AT OPEN POSITION AND CONTROL PANEL REFUEL VALVE IN TRANSIT LIGHT STAYS ON	10-4.4

SYMPTOM	TASK
ERFS II REFUEL VALVE HANDLE NOT AT OPEN POSITION WITH CONTROL PANEL REFUEL VALVE SWITCH SET TO OPEN	10-4.4

SYMPTOM	TASK
ERFS II CONTROL PANEL REFUEL VALVE IN TRANSIT LIGHT DOES NOT COME ON WITH ERFS II REFUEL VALVE OPERATION NORMAL	10-4.4
FUEL REFUEL CIRCUIT BREAKER WILL NOT STAY CLOSED WHEN ERFS II FUEL CONTROL PANEL IS CONNECTED	10-4.4

FUEL SYSTEM ELECTRICAL COMPONENT LOCATION AND CONFIGURATION LIST

REF DESIG	PART NUMBER	TYPE	MATE WITH/LOCATION	STATION LOCATION			REF DESIG	PART NUMBER	TYPE	MATE WITH/LOCATION	STATION LOCATION		
				FS	WL	BL					FS	WL	BL
GD058		151		492	20	50L	174P2	MS3476W8-98S	12	LH AFT FUEL PRESS SWITCH	380	-5	54L
GD109		151		518	10	50R	174P3	MS3476W8-98S	12	RH FWD FUEL PRESS SWITCH	240	-5	54R
GD110		151		508	25	50R	174P4	MS3476W8-98S	12	RH AFT FUEL PRESS SWITCH	380	-5	54R
GD111		151		492	20	50L	174P5	MS3476W14-19P	21	L AUX AFT FUEL TANK PLUG, LH POD	385	-5	52L
GD147		151		230	-10	50L	174J5	MS3474W14-19S	21	L AUX AFT FUEL TANK RCPT	385	-5	52L
GD148		151		230	-10	50L	174P6	MS3476W14-19P	21	R AUX AFT FUEL TANK PLUG RH POD	385	-5	52R
GD149		151		365	-15	50L	174J6	MS3474W14-19S	21	R AUX AFT FUEL TANK RCPT	385	-5	50R
GD150		151		365	-15	50L	174P7	MS3476W14-19S	21	LH FUEL PUMP THERMISTER CONT	340	8	50L
GD151		151		230	-5	50L	174P8	MS3476W14-19S	21	RH FUEL PUMP THERMISTER CONT	340	8	50R
GD153		151		380	-10	50L	232P1	MS3476W22-55S	27	CTR INSTR PNL, MSTR CAUTION PNL			
GD154		151		230	-15	50R	232P2	MS3476W16-26S	24	CTR INSTR PNL, MSTR CAUTION PNL			
GD155		151		230	10	50R	300J1	M83723-74A2041N	40	NO. 1 PDP DISC OVHD PNL RCPT			
GD156		151		230	-20	50R	300P1	M83723-75A2041N	40	NO. 1 PDP DISC OVHD PNL PLUG			
GD158		151		365	-15	50R	300J2	M83723-74A2255N	42	NO. 1 PDP DISC CONSOLE RCPT			
GD159		151		365	-15	50R	300P2	M83723-75A2255N	42	NO. 1 PDP DISC CONSOLE PLUG			
GD160		151		380	-10	50R	300J4	M83723-74A2461N	43	NO. 1 PDP AFT RCPT			
GD175		151		340	30	50L	300P4	M83723-75A2461N	43	NO. 1 PDP AFT PLUG			
GD176		151		348	10	50R	300J5	M83723-74A2041N	40	NO. 2 PDP DISC OVHD PNL RCPT			
GD248		151		348	10	50R	300P5	M83723-75A2041N	40	NO. 2 PDP DISC OVHD PNL PLUG			
GD249		151		348	10	50L	300J6	M83723-74A24616	43	NO. 2 PDP DISC CONSOLE RCPT			
GD265		151		348	32	50L	300P6	M83723-75A24616	43	NO. 2 PDP DISC CONSOLE PLUG			
GD266		151		350	32	50R	300J8	M83723-74A2461 N	42	NO. 2 PDP AFT RCPT			
TB36			OVERHEAD PANEL-COCKPIT				300P8	M83723-75A2461 N	42	NO. 2 PDP AFT PLUG			
171K1		108					300J11	M83723-73A2255N	42	CONSOLE, UNDERFLOOR DISCONNECT	85	-20	
171K2		108	IN LH AND RH FUEL CONTROL	345	0	50L	300P11	M83723-76A2255N	42	CONSOLE, UNDERFLOOR DISCONNECT	85	-20	
174K1		108	RELAY BOX, 171A1	345	0	50R	300J15	M83723-75A24617	43	CONSOLE, UNDERFLOOR DISCONNECT	85	-20	
174K2		108					300P15	M83723-75A24617	43	CONSOLE, UNDERFLOOR DISCONNECT	85	-20	
057P4	M83723-75A2025N	153	J1 FUEL QTY SW BOX	232	2		300J18	M83723-73A2041N	40	OVERHEAD PANEL, COCKPIT			
057P6	M83723-75A20257	153	J3 FUEL QTY SW BOX	232	2		300P18	M83723-76A2041N	40	OVERHEAD PANEL, COCKPIT			
057P11	M83723-75A1624N	35	REFUEL PRECHECK PANEL				300J19	M83723-73A2041N	40	OVERHEAD PANEL, COCKPIT			
057J15	D38999/24WB98SN	330	ERFS II CONTROL RECEPTACLE	353	4	50L	300P19	M83723-76A2041N	40	OVERHEAD PANEL, COCKPIT			
057P16	MS83723-75A1005N	30	ERFS II REFUEL VALVE PLUG	255	-8	54L	300J20	M83723-74A2461N	43	OVERHEAD PANEL, COCKPIT			
171P1	PT06CE-8-3S	12	NO. 1 ENG FUEL PRESS SW	504	10	50L	300P20	M83723-75A2461N	43	OVERHEAD PANEL, COCKPIT			
171P2	PT06CE-8-3S	12	NO. 2 ENG FUEL PRESS SW	504	10	50R	300J21	M83723-74A2461N	43	OVERHEAD PANEL, COCKPIT			
171P3	MS3476W16-26S	24	LH FUEL CONT RELAY BOX, J3	340	8	50L	300P21	M83723-75A2461N	43	OVERHEAD PANEL, COCKPIT			
171P4	MS3476W16-26S	24	RH FUEL CONT RELAY BOX, J3	340	8	50R	300J34	MS3474W16-26P	24	LH FWD FUEL TANK RCPT	245	-15	50L
171P5	MS3476W14-19S	24	LH FUEL CONT RELAY BOX, J5	340	8	50L	300P34	NO PART NUMBER	24	LH FWD FUEL TANK PLUG-LH POD	245	-15	52L
171P6	MS3476W14-19S	21	RH FUEL CONT RELAY BOX, J5	340	8	50R	300J35	MS3474W16-26P	24	LH CABIN, L MAIN TANK RCPT	260	-15	50L
171J7	MS3474W16-26P	24	R MAIN AFT FUEL TANK RCPT	375	-15	50R	300J36	MS3474W16-26P	24	RH FWD AUX FUEL TANK RCPT	245	-15	50R
171J8	MS3474W16-26P	24	L MAIN AFT FUEL TANK RCPT	375	-15	50L	300P36	NO PART NUMBER	24	RH FWD AUX FUEL TANK, PLUG RH POD	245	-15	52R
172P1	MS3476W14-5S	18	NO. 1 ENG FUEL VALVE	498	10	50L	300J37	MS3474W16-26P	24	RH CABIN, R MAIN TANK RCPT	260	-15	50R
172P2	MS3476W14-5S	18	NO. 2 ENG FUEL VALVE	498	15	50R	300J38	MS3474W16-26P	24	LH AFT AUX FUEL TANK RCPT	380	-15	50L
173P1	MS3476W14-5S	18	LH FUEL CROSSFEED VALVE	504	15	50L	300P38	NO PART NUMBER	24	LH AFT AUX FUEL TANK PLUG LH POD	380	-15	52L
173P2	MS3476W14-5S	18	RH FUEL CROSSFEED VALVE	504	15	50R							
174P1	MS3476W8-98S	12	LH FWD FUEL PRESS SWITCH	240	-5	54L							

FUEL SYSTEM ELECTRICAL COMPONENT LOCATION AND CONFIGURATION LIST (Continued)

REF DESIG	PART NUMBER	TYPE	MATE WITH/LOCATION	STATION LOCATION		
				FS	WL	BL
300J39	MS3474W16-26P	24	RH AFT AUX FUEL TANK RCPT	375	-25	50R
300P39	NO PART NUMBER	24	RH AFT AUX FUEL TANK PLUG, RH POD	375	-25	52R
300J40	M83723-73A1415N	34	LH CABIN	222	-5	52L
300P40	M83723-76A1415N	34	LH CABIN	222	-5	52L
300J41	M83723-73A1415N	34	RH CABIN	245	-5	52R
300P41	M83723-76A1415N	34	RH CABIN	245	-5	52R
300J45	M83723-73A2461N	43	HEATER COMPARTMENT	105	40	30R
300P45	M83723-76A2461N	43	HEATER COMPARTMENT	105	40	30R
300J48	M83723-74A2461N	43	ELECTRONICS COMPARTMENT	105	40	20L
300P48	M83723-75A2461N	43	ELECTRONICS COMPARTMENT	105	40	20L
300J51	M83723-74A2461N	43	AFT CROWN-OVHD	460	45	20R
300P51	M83723-75A2461N	43	AFT CROWN-OVHD	460	45	20R
300J52	M83723-74A2255N	42	AFT CROWN-OVHD	460	45	30L
300P52	M83723-75A2255N	42	AFT CROWN-OVHD	460	45	30L
300J55	M83723-73A2255N	42	ELECTRONICS COMPARTMENT (WITHOUT 74)	105	40	20L
300J55	M83723-73W2255N	27	ELECTRONICS COMPARTMENT (WITH 74)	105	40	20L
300P55	M83723-76A2255N	42	ELECTRONICS COMPARTMENT (WITHOUT 74)	105	40	20L
300P55	M83723-76W2255N	27	ELECTRONICS COMPARTMENT (WITH 74)	105	40	20L
300J56	M83723-73A2255N	42	HEATER COMPARTMENT	105	40	25R
300P56	M83723-76A2255N	42	HEATER COMPARTMENT	105	40	25R
300J58	M83723-73A22558	42	CONSOLE, UNDERFLOOR DISCONNECT	85	-20	
300P58	M83723-76A22558	42	CONSOLE, UNDERFLOOR DISCONNECT	85	-20	
300J61	M83723-73A24619	43	CONSOLE, UNDERFLOOR DISCONNECT (WITHOUT 74)	85	-20	
300J61	M83723-73W24619	28	CONSOLE, UNDERFLOOR DISCONNECT (WITH 74)	85	-20	
300P61	M83723-76A24619	43	CONSOLE, UNDERFLOOR DISCONNECT (WITHOUT 74)	85	-20	
300P61	M83723-76W24619	28	CONSOLE, UNDERFLOOR DISCONNECT (WITH 74)	85	-20	

FUEL SYSTEM ELECTRICAL COMPONENT LOCATION AND CONFIGURATION LIST (Continued)

RECEPTACLE

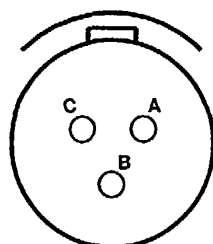

12

PLUG

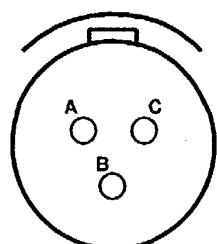

12

RECEPTACLE

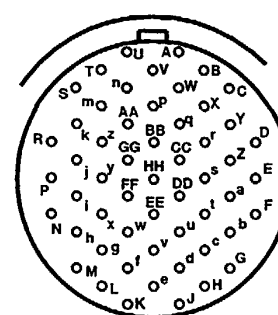

27

PLUG

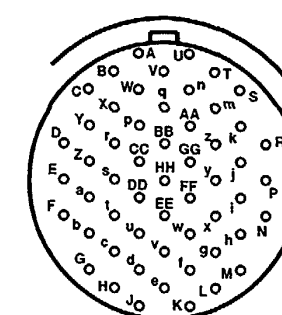

27

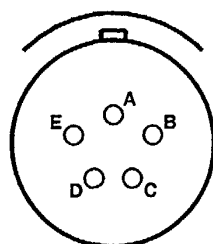

18

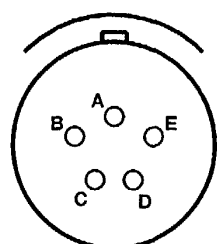

18

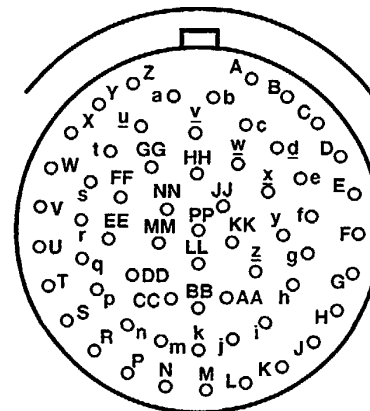

28

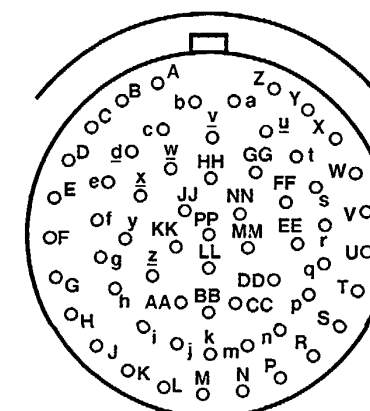

28

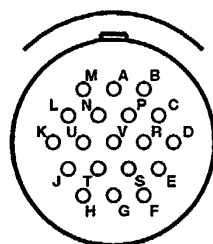

21

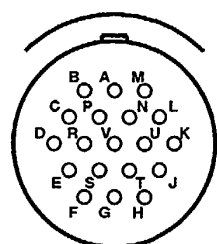

21

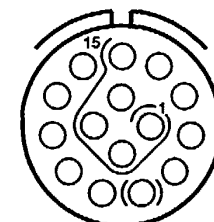

34

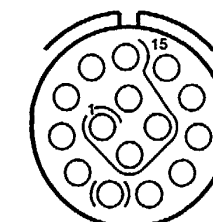

34

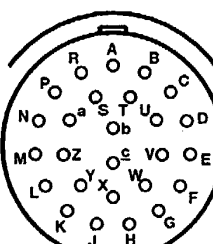

24

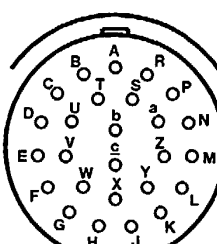

24

A65443

FUEL SYSTEM ELECTRICAL COMPONENT LOCATION AND CONFIGURATION LIST (Continued)

RECEPTACLE

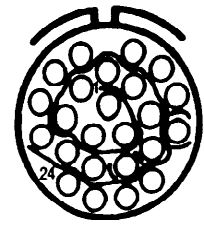

35

PLUG

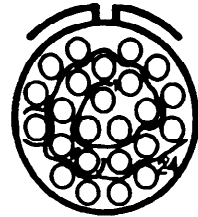

35

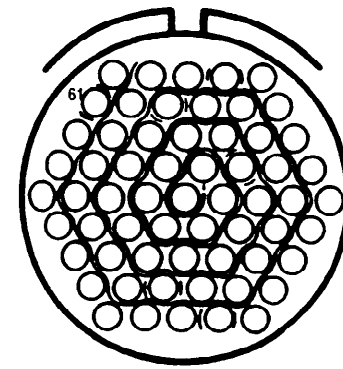

43

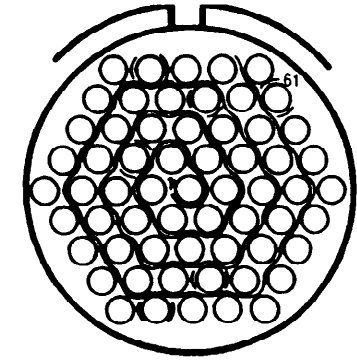

43

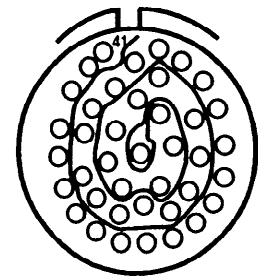

40

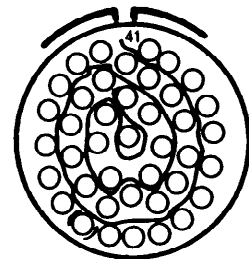

40

RELAY

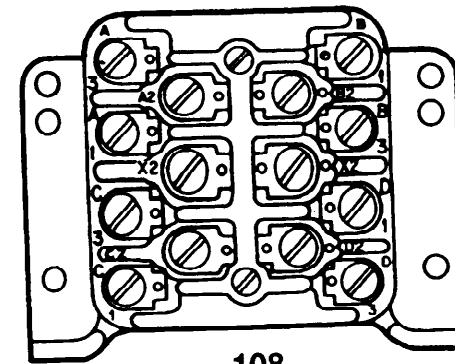

108

GND STUD

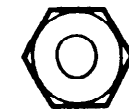

151

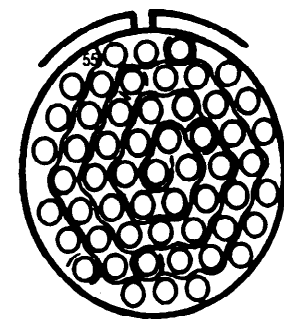

42

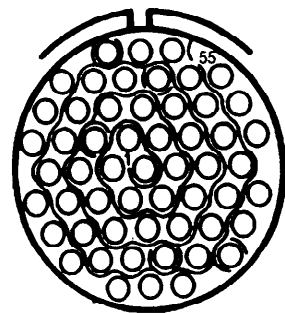

42

RECEPTACLE

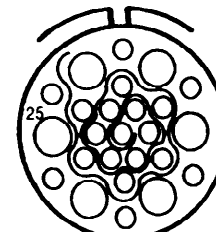

153

PLUG

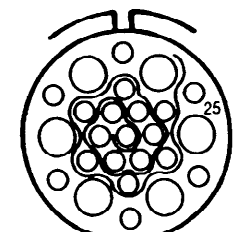

153

RECEPTACLE

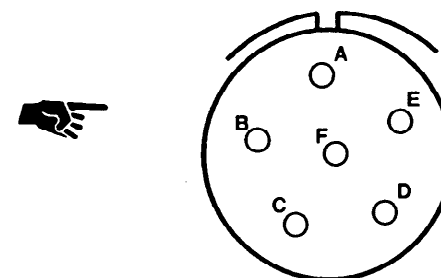

330

PLUG

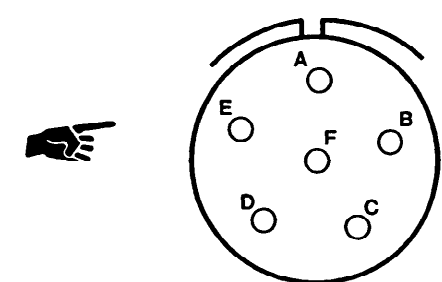

330

A73202

10-1 ENGINE FUEL SHUTOFF AND CROSSFEED VALVES

10-1.1 ENGINE FUEL SHUTOFF AND CROSSFEED VALVES SCHEMATIC DIAGRAM

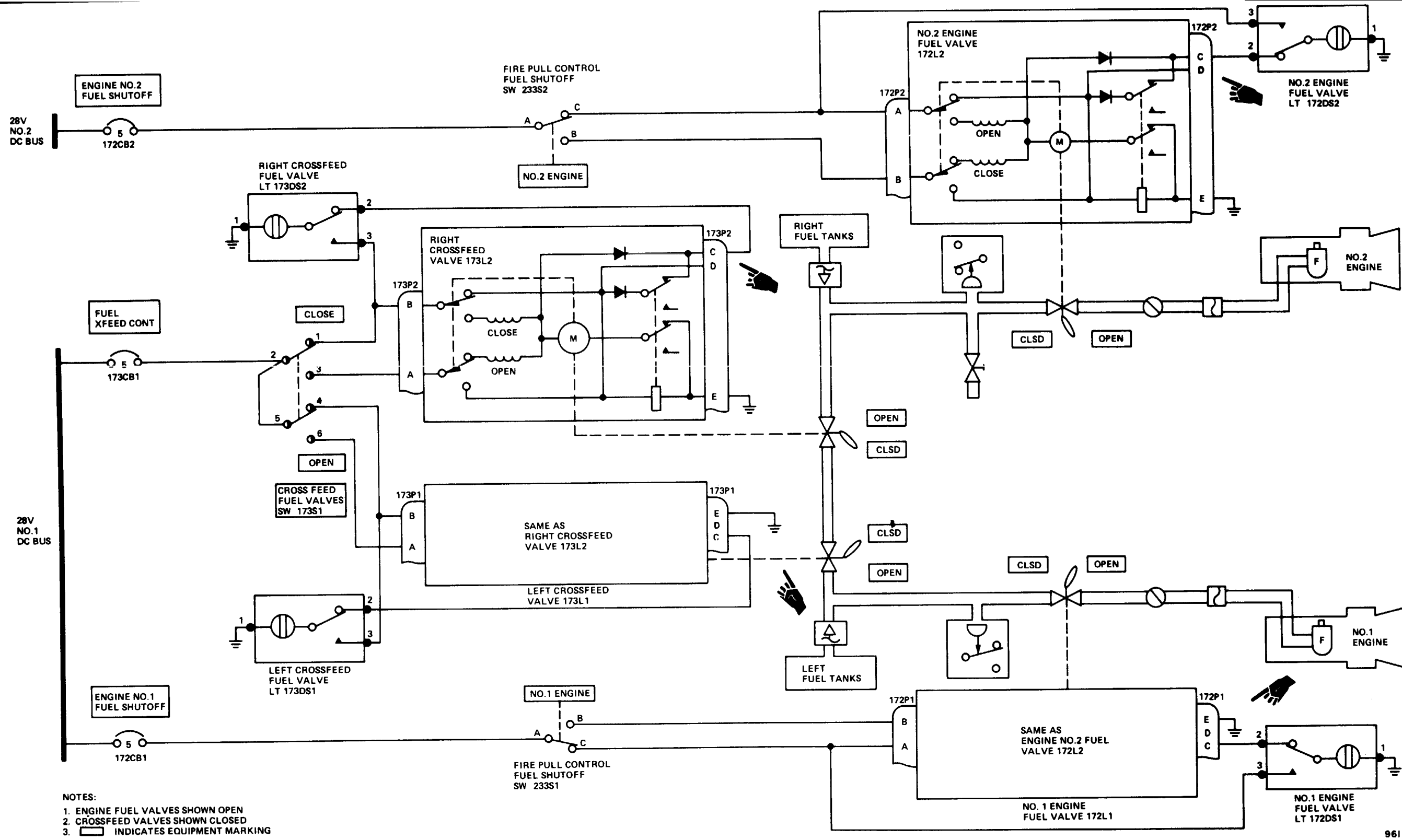

10-1.2 ENGINE FUEL SHUTOFF AND CROSSFEED VALVES WIRING DIAGRAM

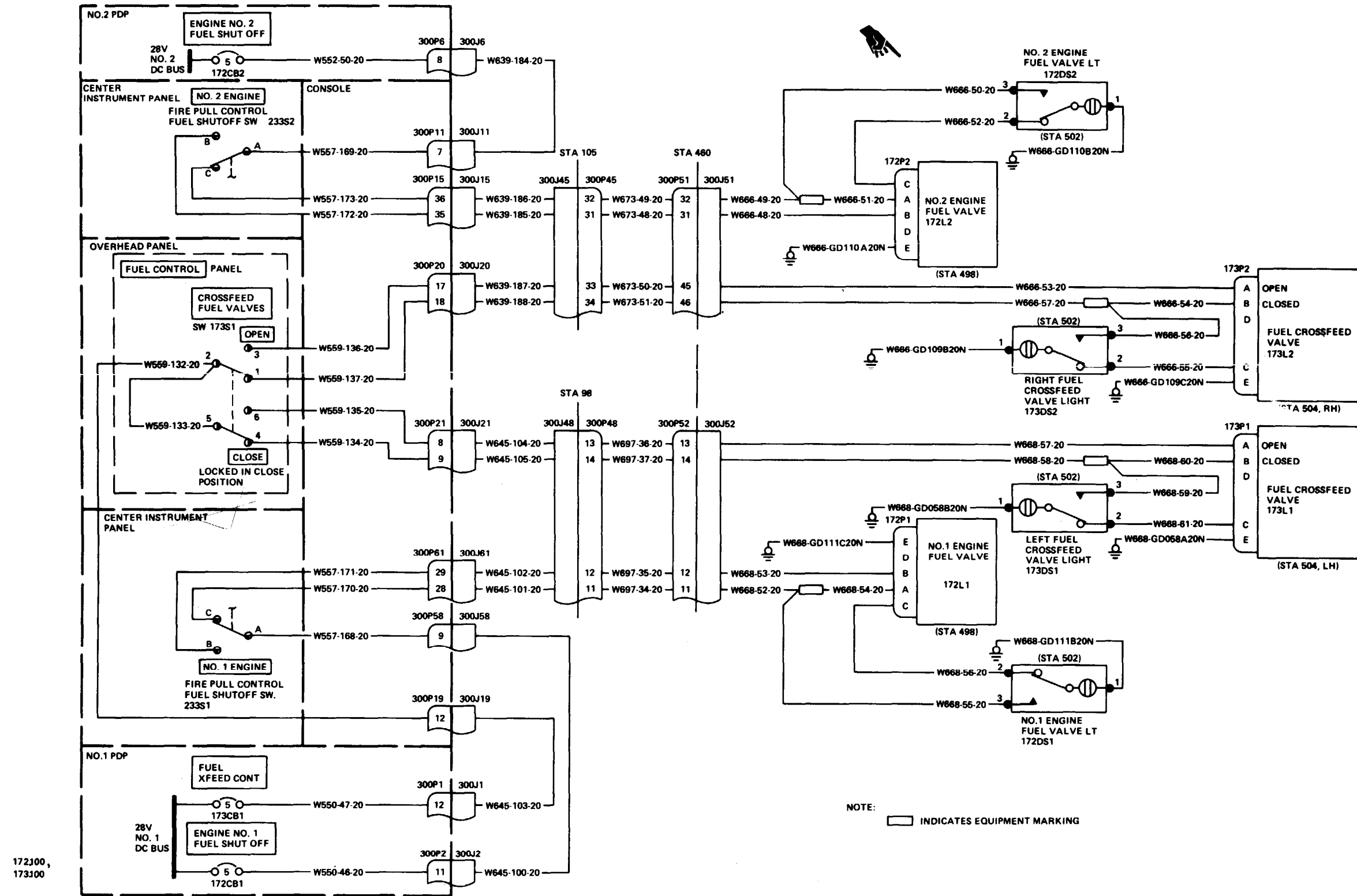

10-1.3 ENGINE FUEL SHUTOFF AND CROSSFEED VALVES
VISUAL CHECK

INITIAL SETUP

Personnel Required:
67U10 Medium Helicopter Repairer

Applicable Configurations:
All

References:
TM 55-1520-240-23

Tools:
Aircraft Mechanic's Tool Kit,
NSN 5180-00-323-4692

Equipment Condition:
TM 55-1520-240-23:
Battery Disconnected
Electrical Power Off
Hydraulic Power Off

Materials:
None

TASK	RESULT
1. Check left crossfeed valve (1).	If valve (1) is loose or damaged, tighten or replace it as required. If wiring or connector (2) is damaged, repair or replace wiring or connector as required.
2. Check No. 1 engine fuel valve (3).	If valve (3) is loose or damaged, tighten or replace it as required. If wiring or connector (4) is damaged, repair or replace wiring, or connector as required.
3. Check left crossfeed valve and No. 1 engine fuel valve lights (5).	If either light (5) is damaged, replace it. If wiring to either light is damaged, repair or replace it as required,
4. Check right crossfeed valve (6).	If valve (6) is loose or damaged, tighten or replace it as required. If wiring or connector (7) is damaged, repair or replace wiring or connector as required.
5. Check No. 2 engine fuel valve (8).	If valve (8) is loose or damaged, tighten or replace it as required, If wiring or connector (9) is damaged, repair or replace wiring or connector as required.
6. Check right crossfeed valve and No. 2 engine fuel valve lights (10).	If either light (10) is damaged, replace it. If wiring to either light is damaged, repair or replace it as required.
7. Check CROSSFEED FUEL VALVES switch (11).	If switch (11) is loose or damaged, tighten or replace it as required.

FOLLOW-ON MAINTENANCE:

None

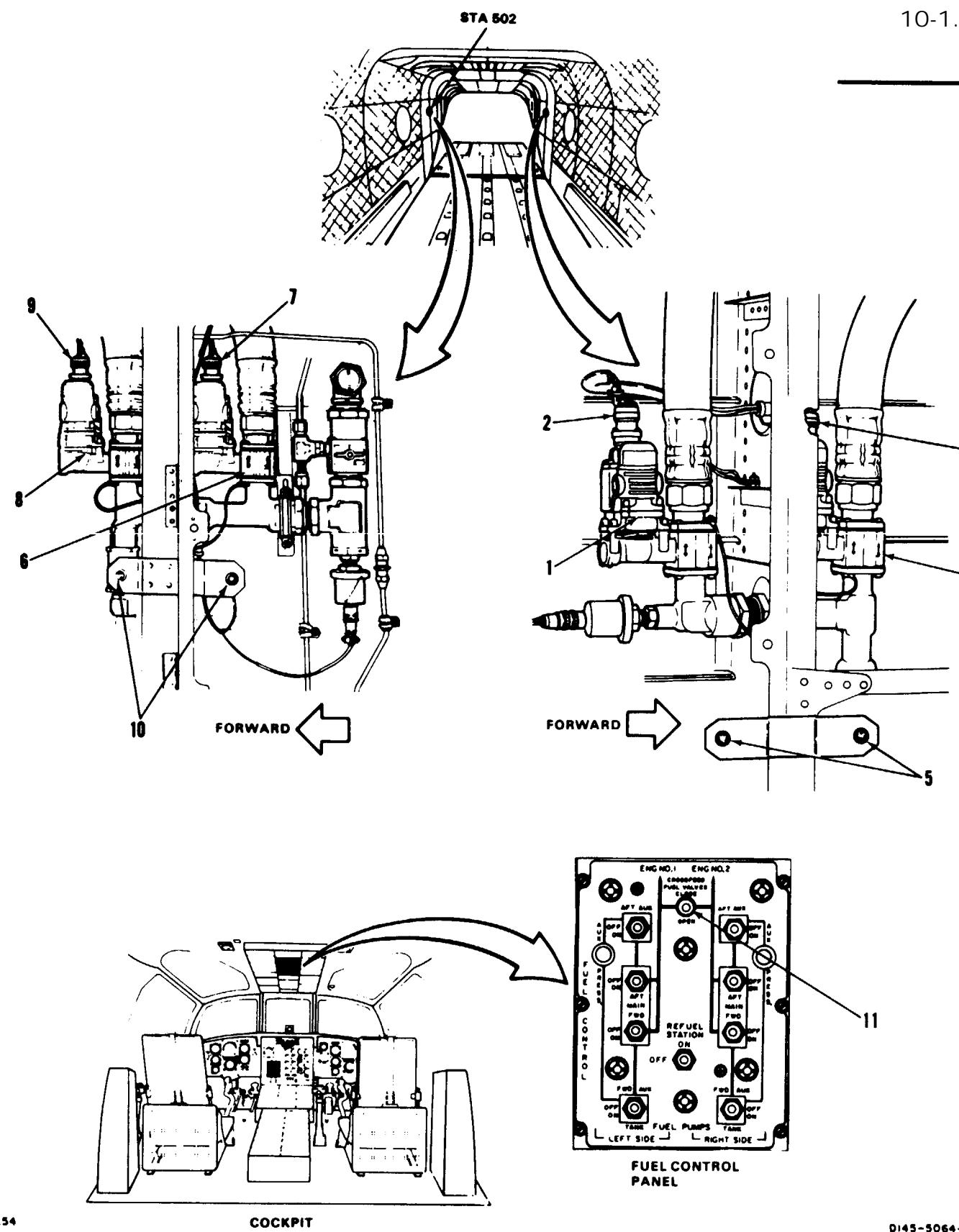

10-1.4 ENGINE FUEL SHUTOFF AND CROSSFEED VALVES
OPERATIONAL CHECK

INITIAL SETUP

Applicable Configurations:
All

Tools:
None

Materials:
None

Personnel Required:
68F20 Aircraft Electrician
67U10 Medium Helicopter Repairer

References:
TM 55-1520-240-23

Equipment Condition:
TM 55-1520-240-23:
Battery Connected
Electrical Power On
Hydraulic Power Off
Engine Fuel Shutoff And Crossfeed
Valves Visual Check Performed (Task 10- 1.3)

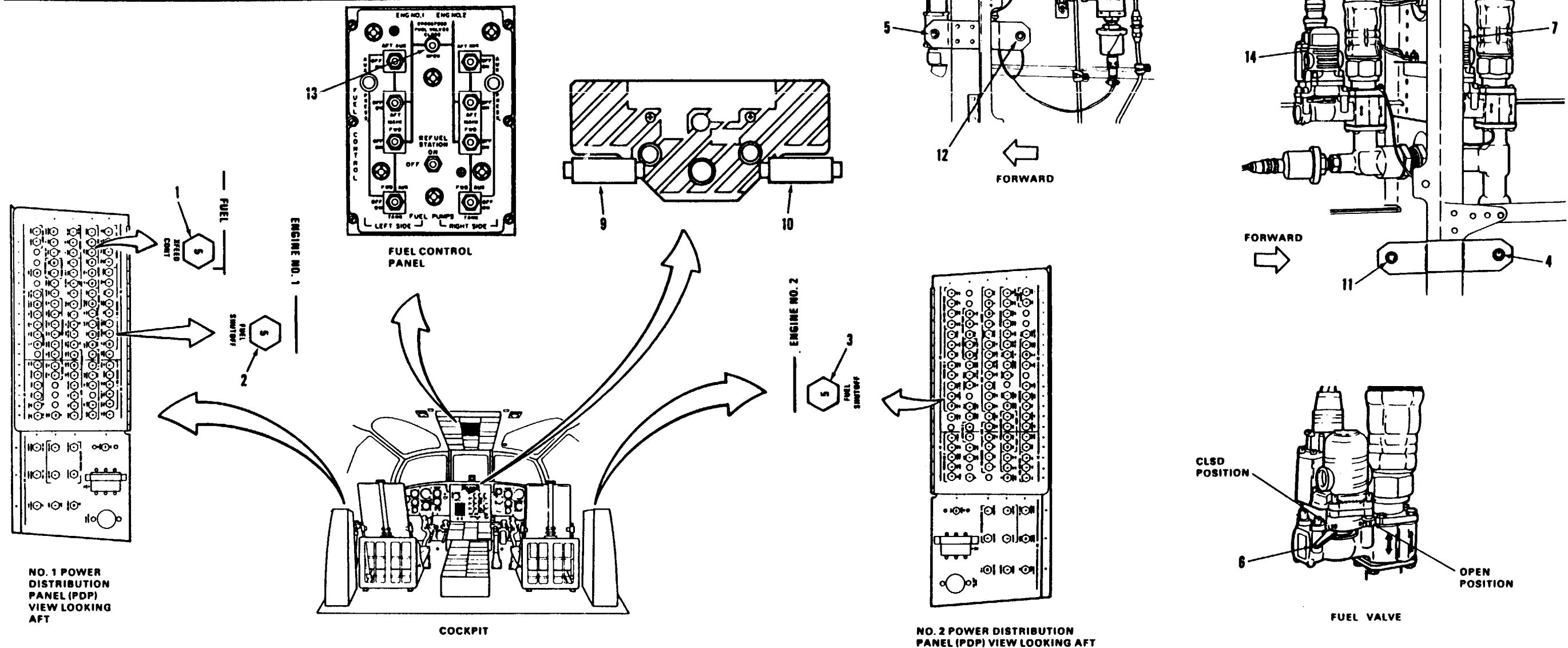

90X54

10-1.4 ENGINE FUEL SHUTOFF AND CROSSFEED VALVES
OPERATIONAL CHECK (Continued)

10-1.4

TASK	RESULT
CHECK CIRCUIT BREAKERS	
1. Check that FUEL XFEED CONT circuit breaker (1) is closed.	If XFEED CONT circuit breaker (1) is open, close it. If it opens again, go to task 10-1.5.
2. Check that ENGINE NO. 1 FUEL SHUTOFF circuit breaker (2) is closed.	If FUEL SHUTOFF circuit breaker (2) is open, close it. If it opens again, go to task 10-1.6.
3. Check that ENGINE NO. 2 FUEL SHUTOFF circuit breaker (3) is closed.	If FUEL SHUTOFF circuit breaker (3) is open, close it. If it opens again, go to task 10-1.6.
CHECK ENGINE FUEL SHUTOFF VALVES	
4. Press and release No. 1 engine fuel valve light (4).	Light (4) shall momentarily come on. If it does not, go to task 10-1.7.
5. Press and release No. 2 engine fuel valve light (5).	Light (5) shall momentarily come on. If it does not, go to task 10-1.8.
6. Open ENGINE NO. 1 FUEL SHUTOFF circuit breaker (2) and ENGINE NO. 2 FUEL SHUTOFF circuit breaker (3).	
7. Set handles (6) on No 1 engine fuel valve (7) and No 2 engine fuel valve (8) to CLSD.	If handle (6) cannot be moved to CLSD, replace No. 1 or No. 2 engine fuel valve as required.
8. Close ENGINE NO. 1 FUEL SHUTOFF circuit breaker (2).	Handle (6) on No. 1 engine fuel valve (7) shall move to OPEN. No. 1 engine fuel valve light (4) shall come on and remain on until handle is at OPEN. If handle is not at OPEN or light comes on and stays on, go to task 10-1.9. If light did not come on but handle is at OPEN, go to task 10-1.10. If light is on and handle is at OPEN, replace No. 1 engine fuel valve.
9. Close ENGINE NO. 2 FUEL SHUTOFF circuit breaker (3).	Handle (6) on No. 2 engine fuel valve (8) shall move to OPEN. No. 2 engine fuel valve light (5) shall come on and remain on until handle is at OPEN. If handle is not at OPEN or light comes on and stays on, go to task 10-1.9. If light did not come on but handle is at OPEN, go to task 10-1.10. If light is on and handle is at OPEN, replace No. 2 engine fuel valve.

CAUTION

Do not operate FIRE AGENT switch while fire handles are out. Fire bottles will discharge into engines.

TASK	RESULT
10. Pull out No. 1 ENGINE fire handle (9).	Handle (6) on No. 1 engine fuel valve (7) shall move to CLSD. No. 1 engine fuel valve light (4) shall come on and remain on until handle is at CLSD. If handle is not at CLSD or light (4) comes on and stays on, go to task 10-1.11. If light did not come on but handle is at CLSD, go to task 10-1.10. If light is on and handle is at CLSD, replace No. 1 engine fuel valve.
11. Pull out No. 2 ENGINE fire handle (10).	Handle (6) on No. 2 engine fuel valve (8) shall move to CLSD. No. 2 engine fuel valve light (5) shall come on and remain on until handle is at CLSD. If handle is not at CLSD or light comes on and stays on, go to task 10-1.11. If light (4) did not come on but handle (6) is at CLSD, go to task 10-1.10. If light is on and handle is at CLSD, replace No. 2 engine fuel valve.
12. Open ENGINE NO. 1 FUEL SHUTOFF circuit breaker (2) and ENGINE NO. 2 FUEL SHUTOFF circuit breaker (3).	
13. Set handles (6) on No. 1 engine fuel valve (7) and No. 2 engine fuel valve (8) to OPEN.	
14. Close ENGINE NO. 1 FUEL SHUTOFF circuit breaker (2).	Handle (6) on No. 1 engine fuel valve (7) shall move to CLSD. No. 1 engine fuel valve light (4) shall come on and remain on until handle is at CLSD. If not, replace No. 1 engine fuel valve.
15. Close ENGINE NO. 2 FUEL SHUTOFF circuit breaker (3).	Handle (6) on No. 2 engine fuel valve (8) shall move to CLSD. No. 2 engine fuel valve light (5) shall come on and remain on until handle is at CLSD, If not, replace No. 2 engine fuel valve
16. Push in No. 1 ENGINE fire handle (9).	Handle (6) on No 1 engine fuel valve (7) shall move to OPEN. If not, replace No. 1 ENGINE fire pull control.
17. Push in No. 2 ENGINE fire handle (10).	Handle (6) on No. 2 engine fuel valve (8) shall move to OPEN, If not, replace No. 2 ENGINE fire pull control.
CHECK CROSSFEED VALVES	
18. Press and release left crossfeed fuel valve light (11).	Light (11) shall momentarily come on. If it does not, go to task 10-1.12.

GO TO NEXT PAGE

**10-1.4 ENGINE FUEL SHUTOFF AND CROSSFEED VALVES
OPERATIONAL CHECK (Continued)**

TASK	RESULT
19. Press and release right crossfeed fuel valve light (12).	Light (12) shall momentarily come on. If it does not, go to task 10-1.13.
20. Set CROSSFEED FUEL VALVES switch (13) to OPEN.	Handles (6) on left crossfeed fuel valve (14) and right crossfeed fuel valve (15) shall move to OPEN. Left and right crossfeed fuel valve lights (11 and 12) shall come on and remain on until handles are at OPEN. If either crossfeed fuel valve handle is not at OPEN or light comes on and stays on, go to task 10-1.14. If either light did not come on but handle is at OPEN, go to task 10-1.15. If either light is on and handle is at OPEN, replace faulty crossfeed fuel valve.
21. Open FUEL XFEED CONT circuit breaker (1).	
22. Set handle (6) on left and right crossfeed fuel valves (14 and 15) to CLSD.	If handle (6) cannot be moved to CLSD, replace left or right crossfeed fuel valve, as required.
23. Close FUEL XFEED CONT circuit breaker (1).	Handles (6) on left and right crossfeed fuel valves (14 and 15) shall move to OPEN. Left and right crossfeed fuel valve lights (11 and 12) shall come on and remain on until handles are at OPEN. If not, replace faulty crossfeed fuel valve.
24. Set CROSSFEED FUEL VALVES switch (13) to CLOSE.	Handles (6) on left and right crossfeed fuel valves (14 and 15) shall move to CLSD. Left and right crossfeed fuel valve lights (11 and 12) shall come on and remain on until handles are at CLSD. If either crossfeed fuel valve handle is not at CLSD or light comes on and stays on, go to task 10-1.16. If either light did not come on but handles are at CLSD, go to task 10-1.15. If light is on and handle is at OPEN, replace faulty crossfeed fuel valve.
25. Open FUEL XFEED CONT circuit breaker (1).	
26. Set handle (6) on left and right crossfeed fuel valves (14 and 15) to OPEN.	

TASK	RESULT
27. Close FUEL XFEED CONT circuit breaker (1).	Handles (6) on left and right crossfeed fuel valves (14 and 15) shall move to CLSD. Left and right crossfeed fuel valve lights (11 and 12) shall come on and remain on until handles are at CLSD. If either handle is not at CLSD or light comes on and stays on, replace faulty crossfeed fuel valve.

FOLLOW-ON MAINTENANCE:

TM 55-1520-240-23:
Electrical Power Off
Disconnect Battery

GO TO NEXT PAGE

10-1.4 ENGINE FUEL SHUTOFF AND CROSSFEED VALVES
OPERATIONAL CHECK (Continued)

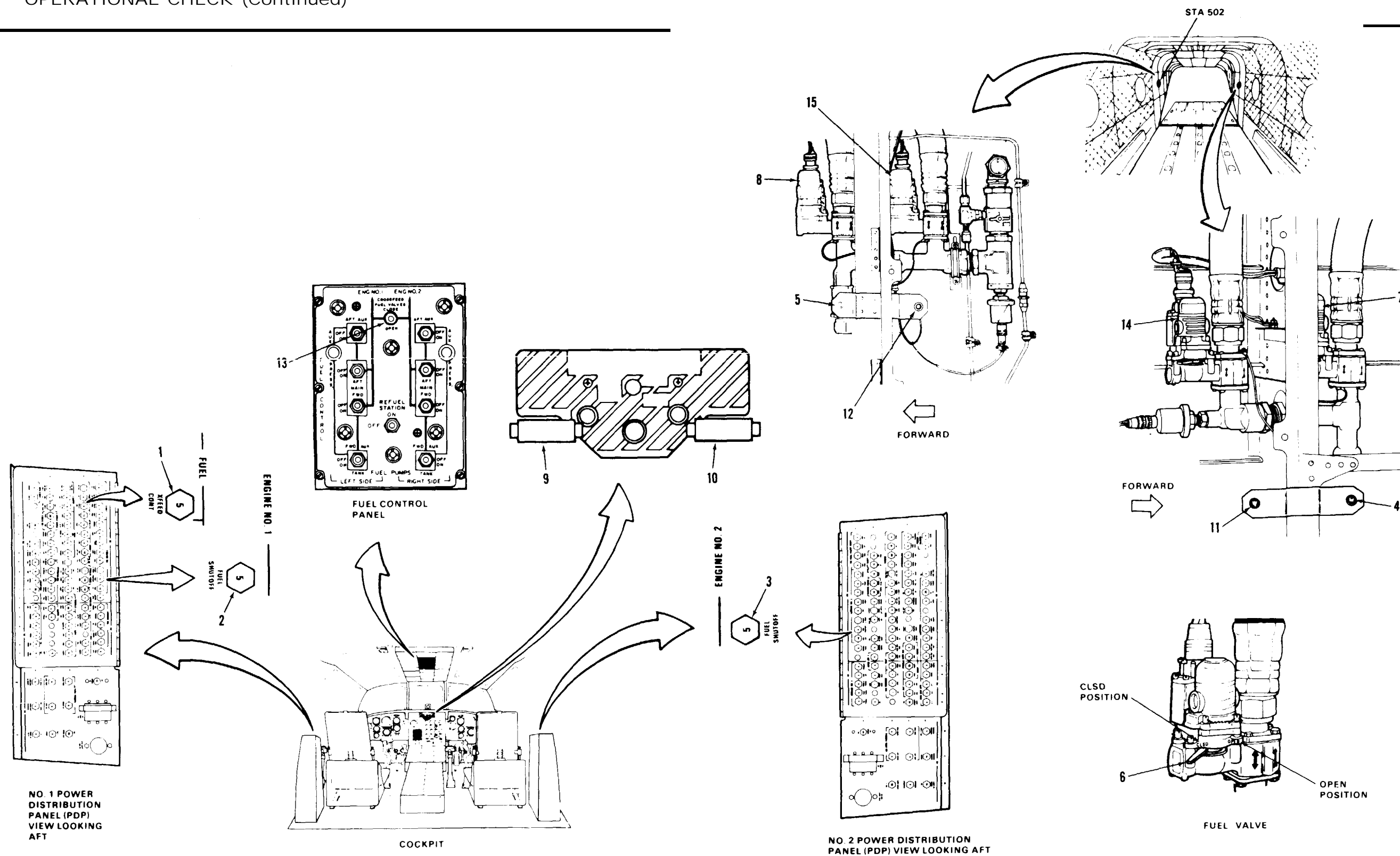

90 X 54

0145-11830-SPA

END OF TASK

10-1.5 FUEL XFEED CONT CIRCUIT BREAKER DOES NOT STAY CLOSED

FAULT ISOLATION PROCEDURE

INITIAL SETUP

Applicable Configurations:
All

Tools:
Electrical Repairer's Tool Kit,
NSN 5180-00-323-4915
Multimeter

Materials:
None

Personnel Required:
68F10 Aircraft Electrician
68F20 Aircraft Electrician

References:
TM 55-1520-240-23

Equipment Condition:
TM 55-1520-240-23
Battery Disconnected
Electrical Power Off
Hydraulic Power Off

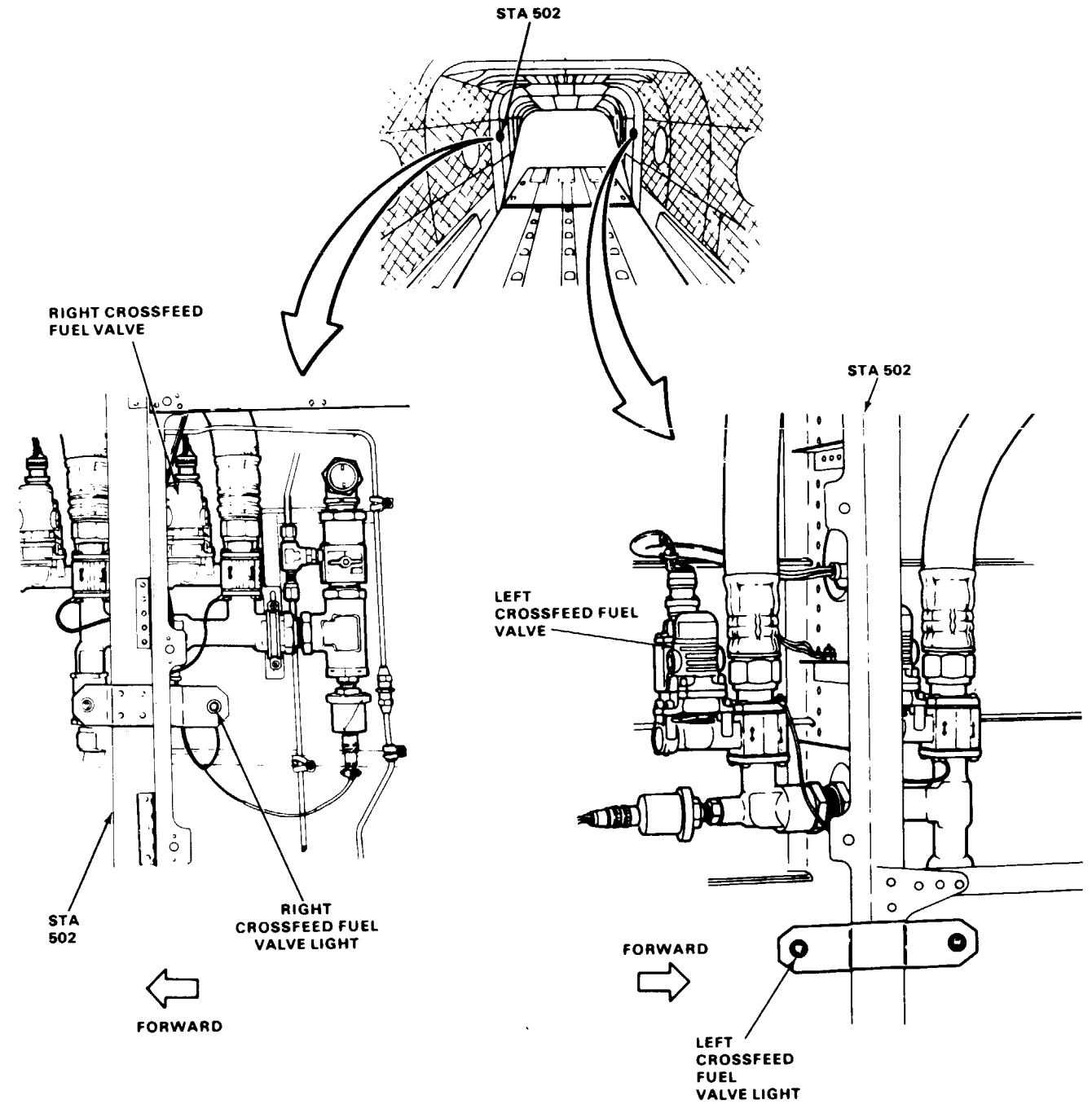
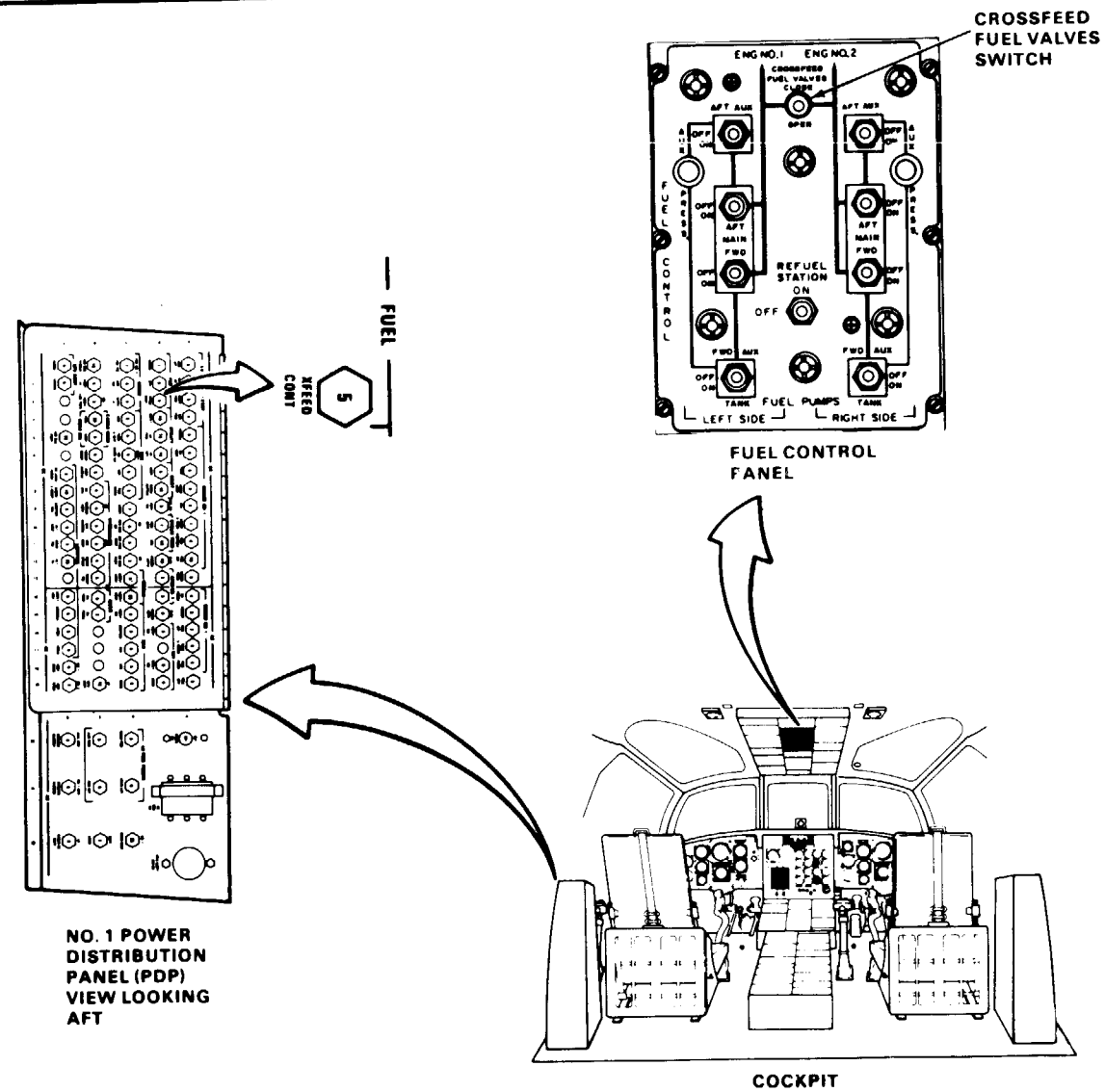

D145-5066-SPA
GO TO NEXT PAGE

10-1.5 FUEL XFEED CONT CIRCUIT BREAKER DOES NOT STAY CLOSED (Continued)

10-1.5

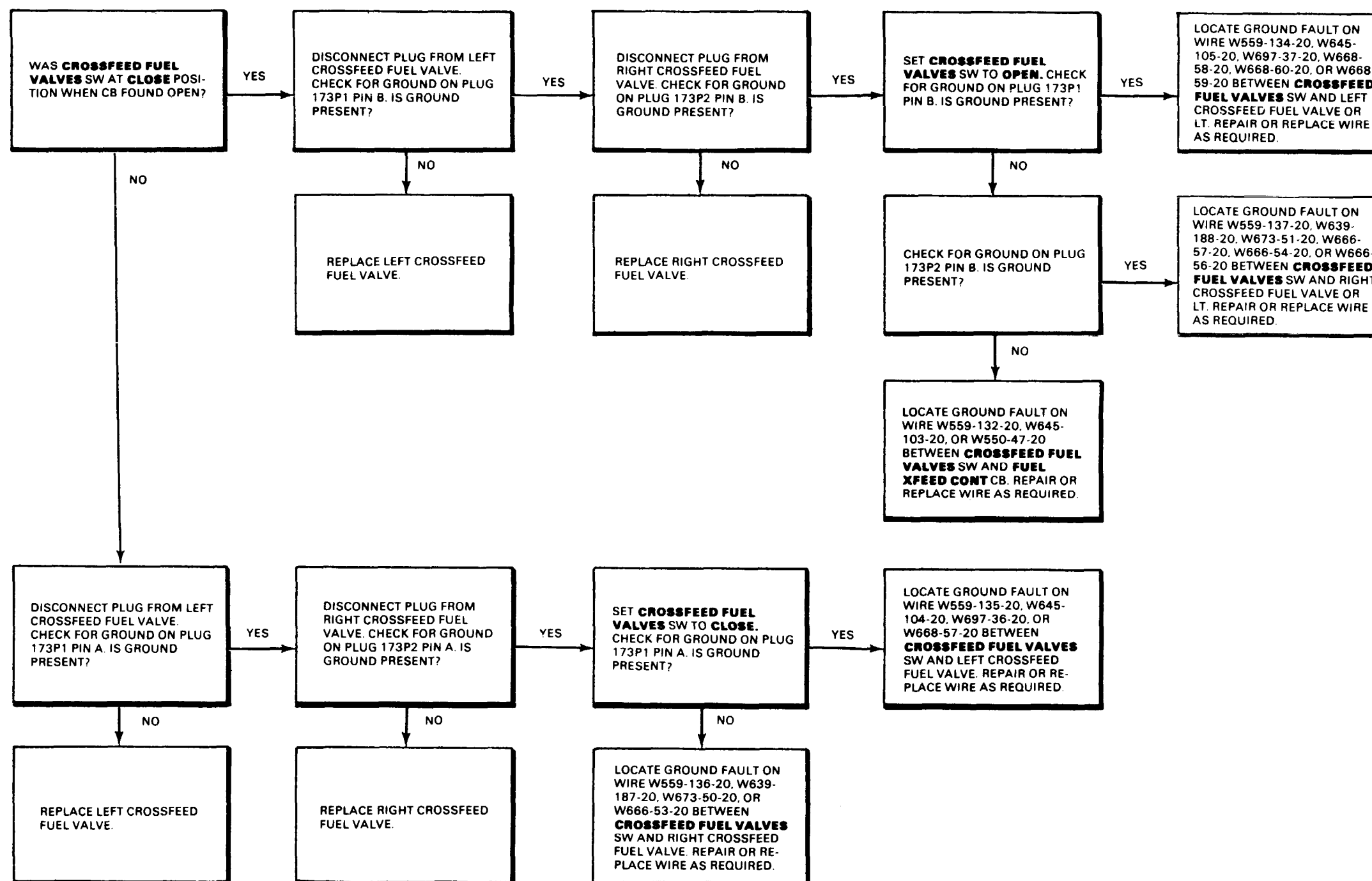

END OF TASK

10-1.6 ENGINE FUEL SHUTOFF CIRCUIT BREAKER DOES NOT STAY CLOSED

FAULT ISOLATION PROCEDURE

INITIAL SETUP

Applicable Configurations:

All

Tools:

Electrical Repairer's Tool Kit,

NSN 5180-00-323-4915

Multimeter

Materials:

None

Personnel Required:

68F10 Aircraft Electrician

68F20 Aircraft Electrician

References:

TM 55-1520-240-23

Equipment Condition:

TM 55-1520-240-23:

Battery Disconnected

Electrical Power Off

Hydraulic Power Off

FUEL SHUTOFF SWITCH

TYPICAL FIRE PULL CONTROL VIEW LOOKING AFT

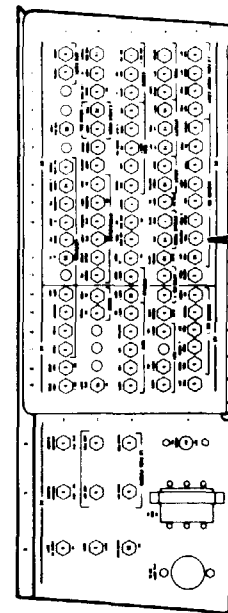

NO. 1 POWER DISTRIBUTION PANEL (PDP) VIEW LOOKING AFT

ENGINE NO. 1 FUEL SHUTOFF

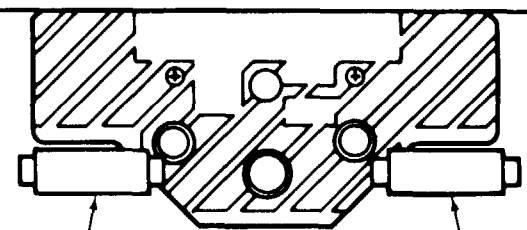

NO. 1 ENGINE FIRE HANDLE

NO. 2 ENGINE FIRE HANDLE

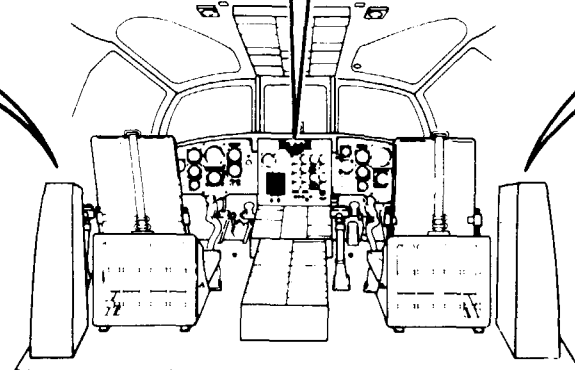

COCKPIT

ENGINE NO. 2 FUEL SHUTOFF

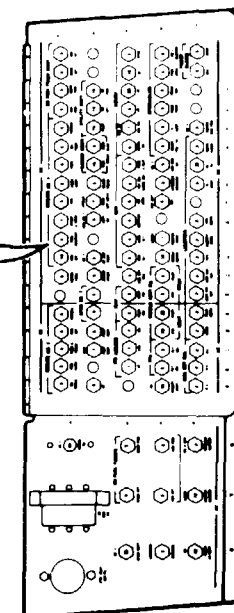

NO. 2 POWER DISTRIBUTION PANEL (PDP) VIEW LOOKING AFT

NO. 2 ENGINE FUEL VALVE

NO. 2 ENGINE FUEL VALVE LIGHT

STA 502

FORWARD

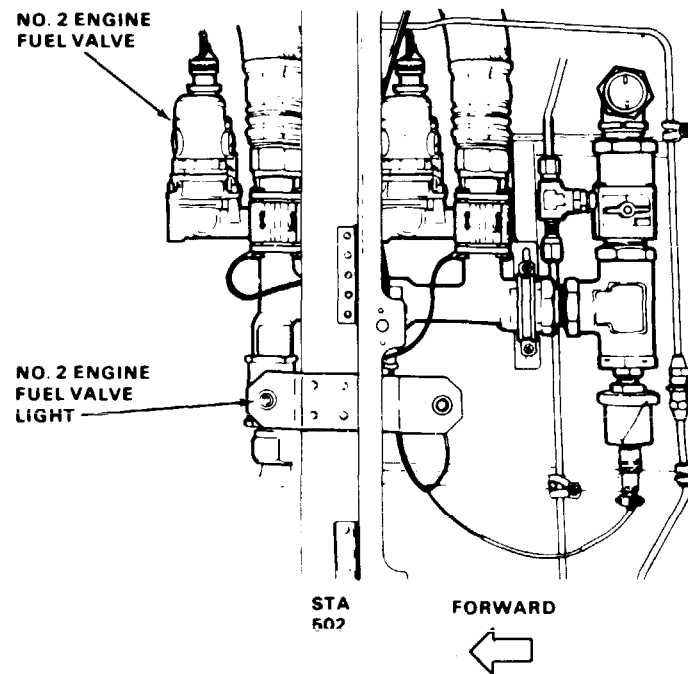

STA 502

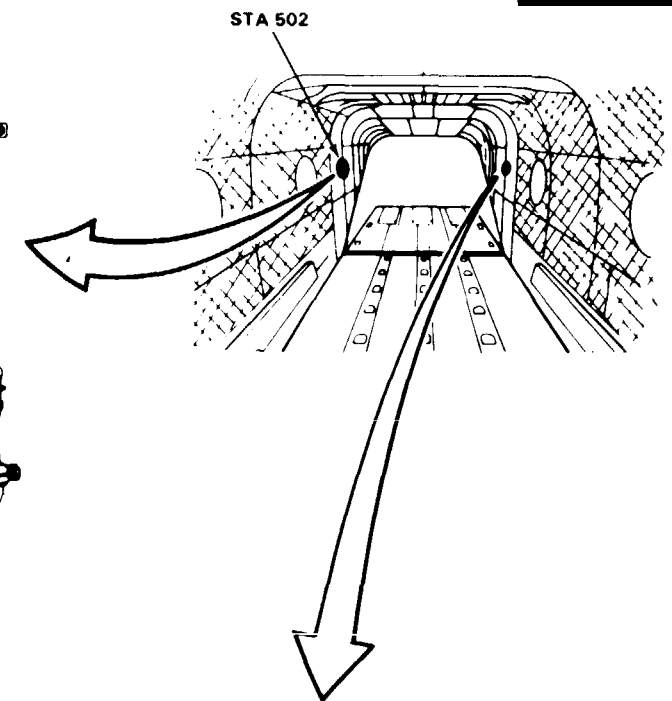

NO. 1 ENGINE FUEL VALVE

FORWARD

STA 502

NO. 1 ENGINE FUEL VALVE LT

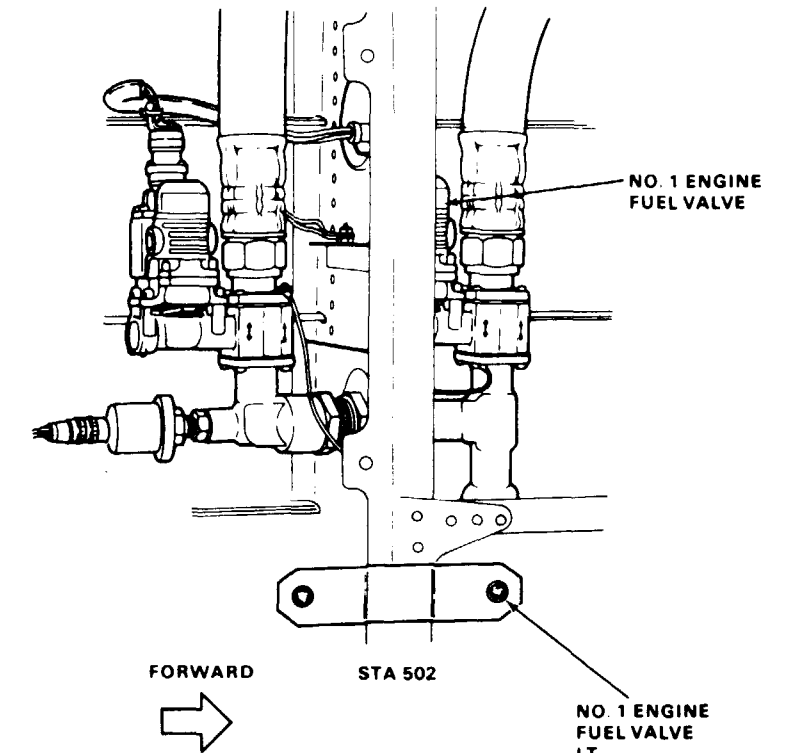

10-1.6 ENGINE FUEL SHUTOFF CIRCUIT BREAKER DOES NOT STAY CLOSED (Continued)

ENGINE NO. 1 FUEL SHUTOFF CIRCUIT BREAKER DOES NOT STAY CLOSED

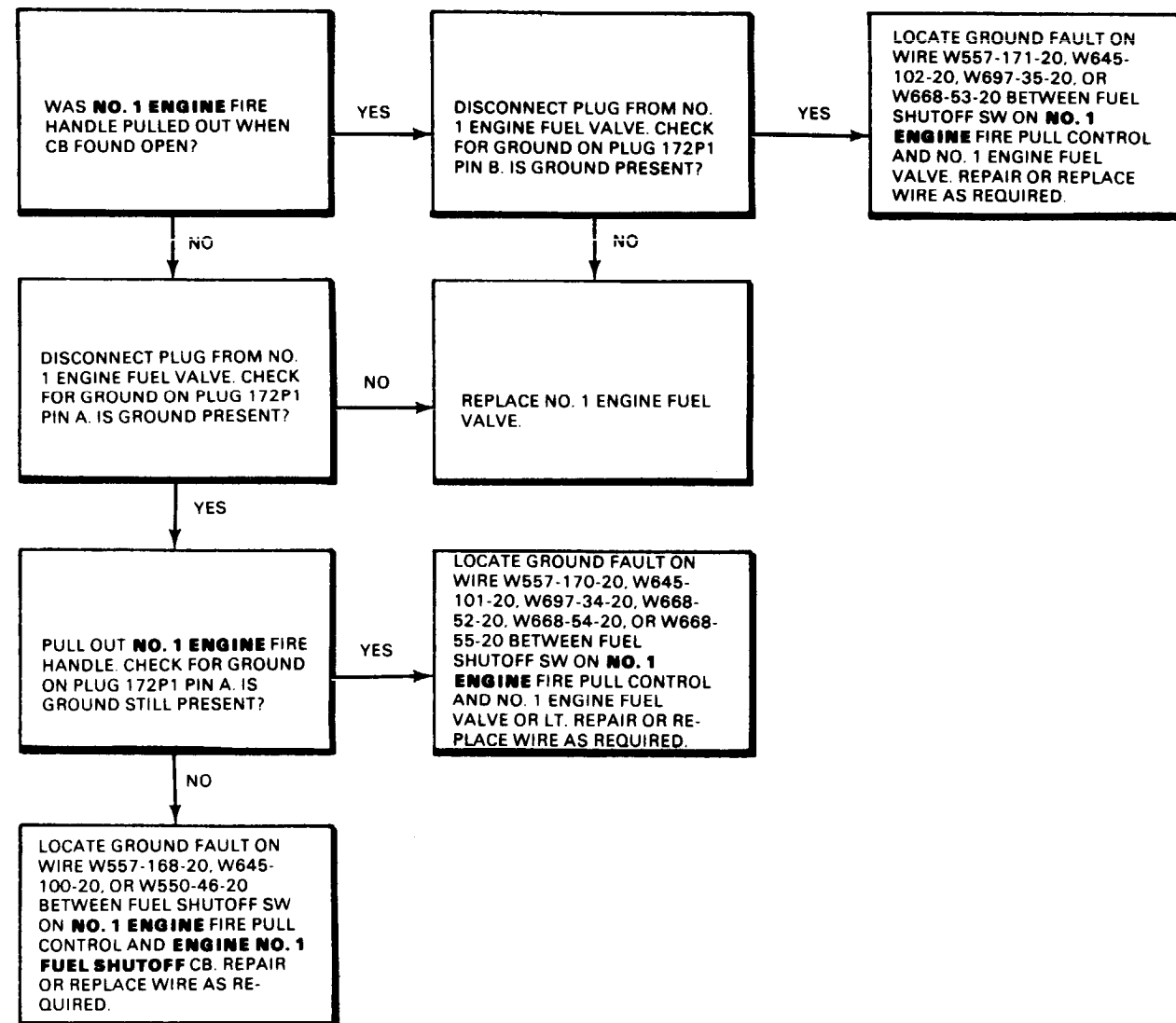

ENGINE NO. 2 FUEL SHUTOFF CIRCUIT BREAKER DOES NOT STAY CLOSED

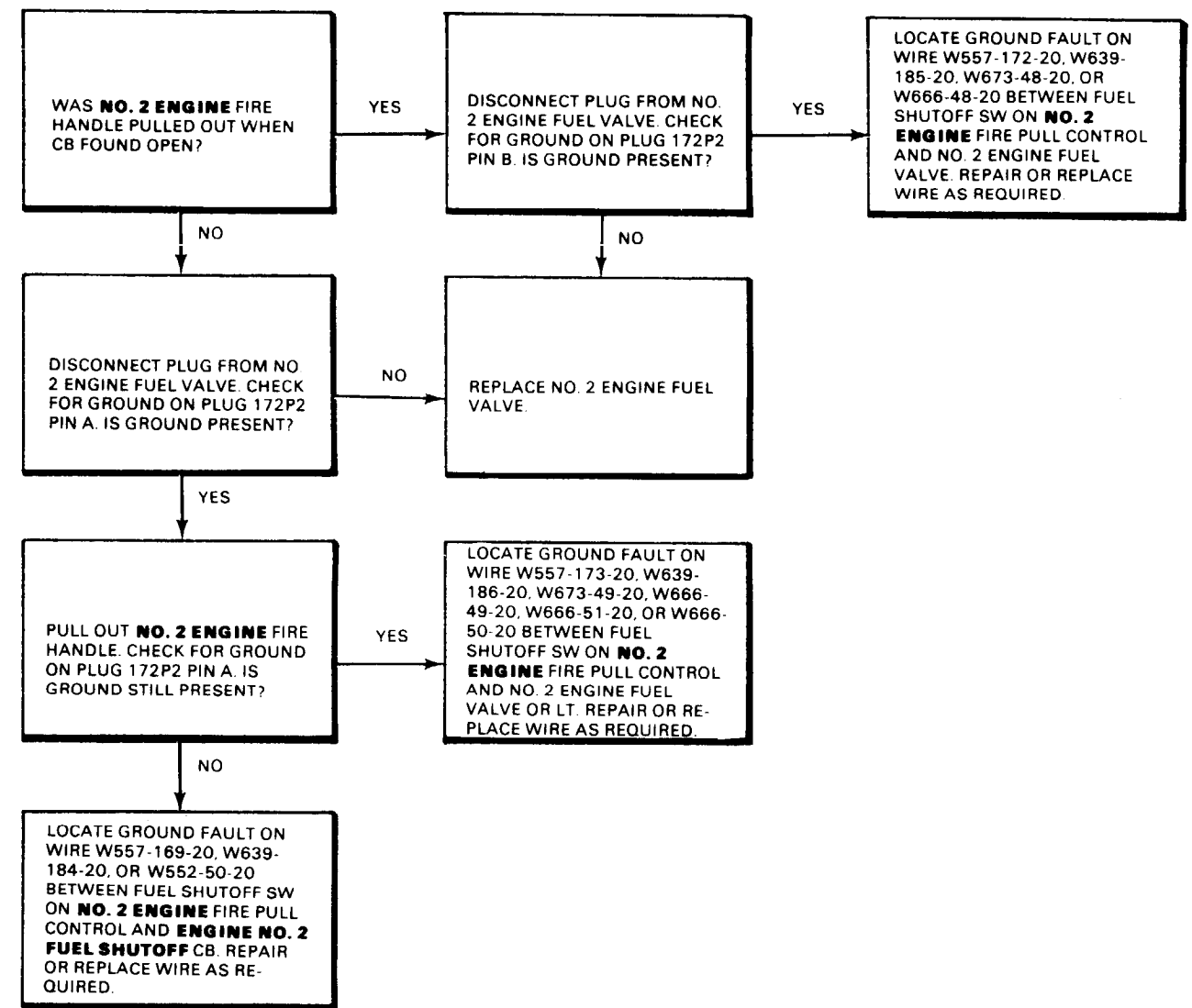

END OF TASK

10-1.7 NO. 1 ENGINE FUEL VALVE LIGHT DOES NOT COME ON DURING PRESS-TO-TEST

FAULT ISOLATION PROCEDURE

INITIAL SETUP

Applicable Configurations:
All

Tools:
Electrical Repairer's Tool Kit,
NSN 5180-00-323-4915
Multimeter

Materials:
None

Personnel Required:
68F10 Aircraft Electrician
68F20 Aircraft Electrician

References:
TM 55-1520-240-23

Equipment Condition:
TM 55-1520-240-23:
Battery Connected
Electrical Power On
Hydraulic Power Off

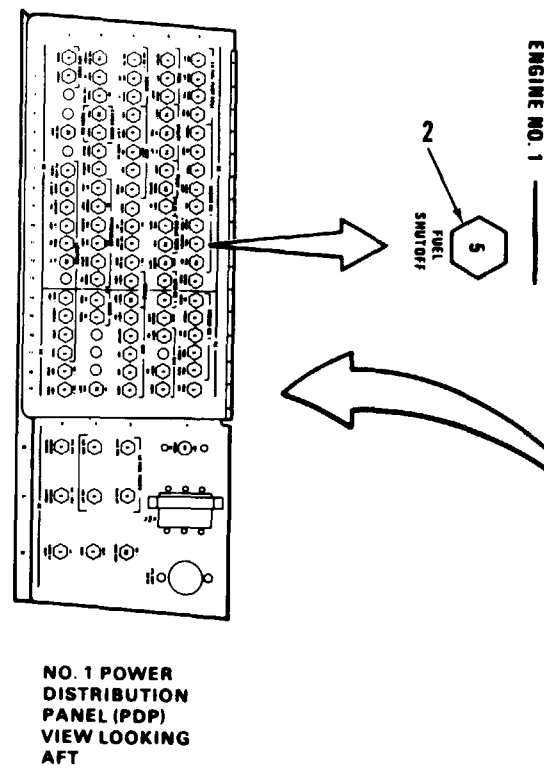
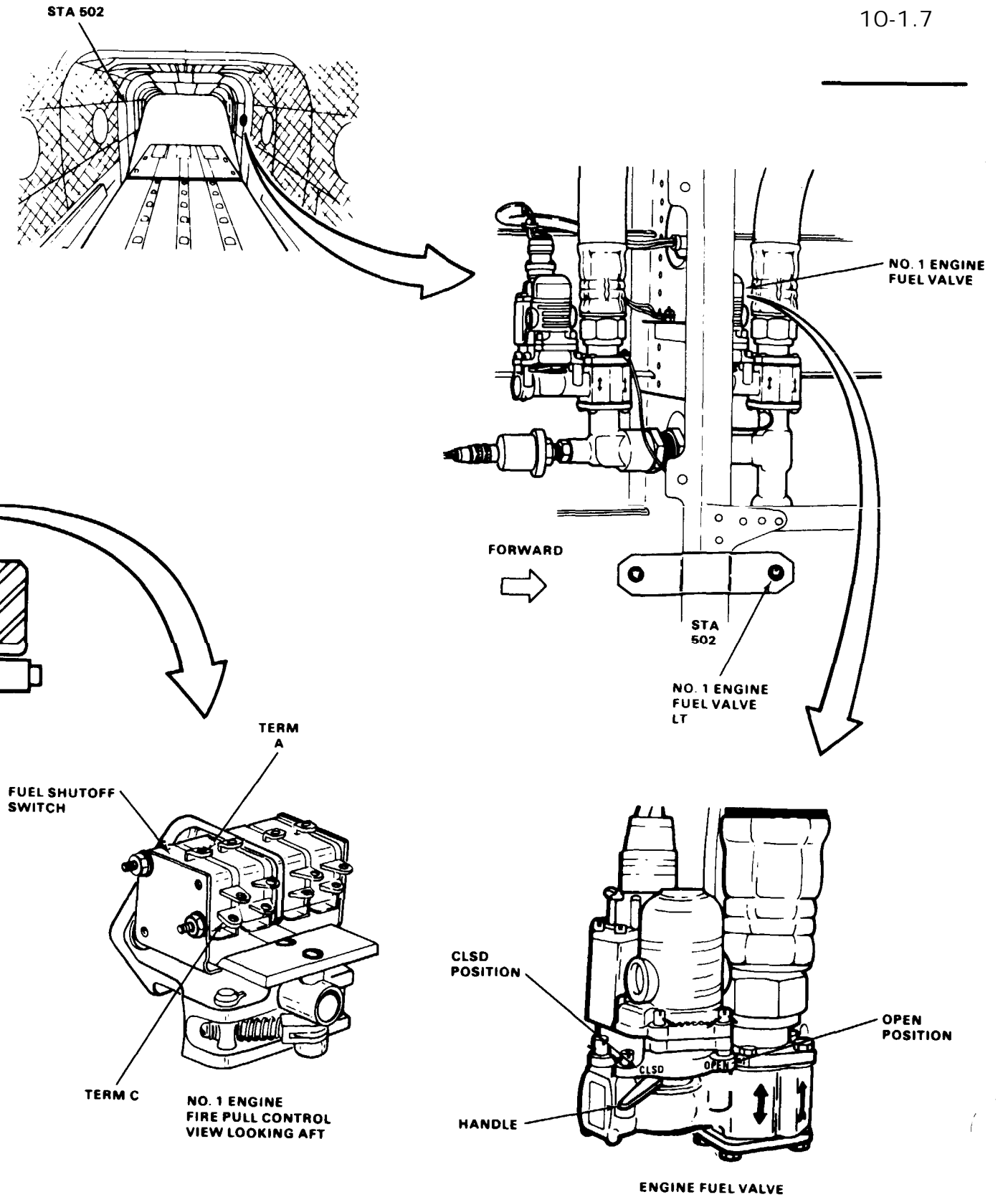

90x54

D145-5068-SPA

GO TO NEXT PAGE

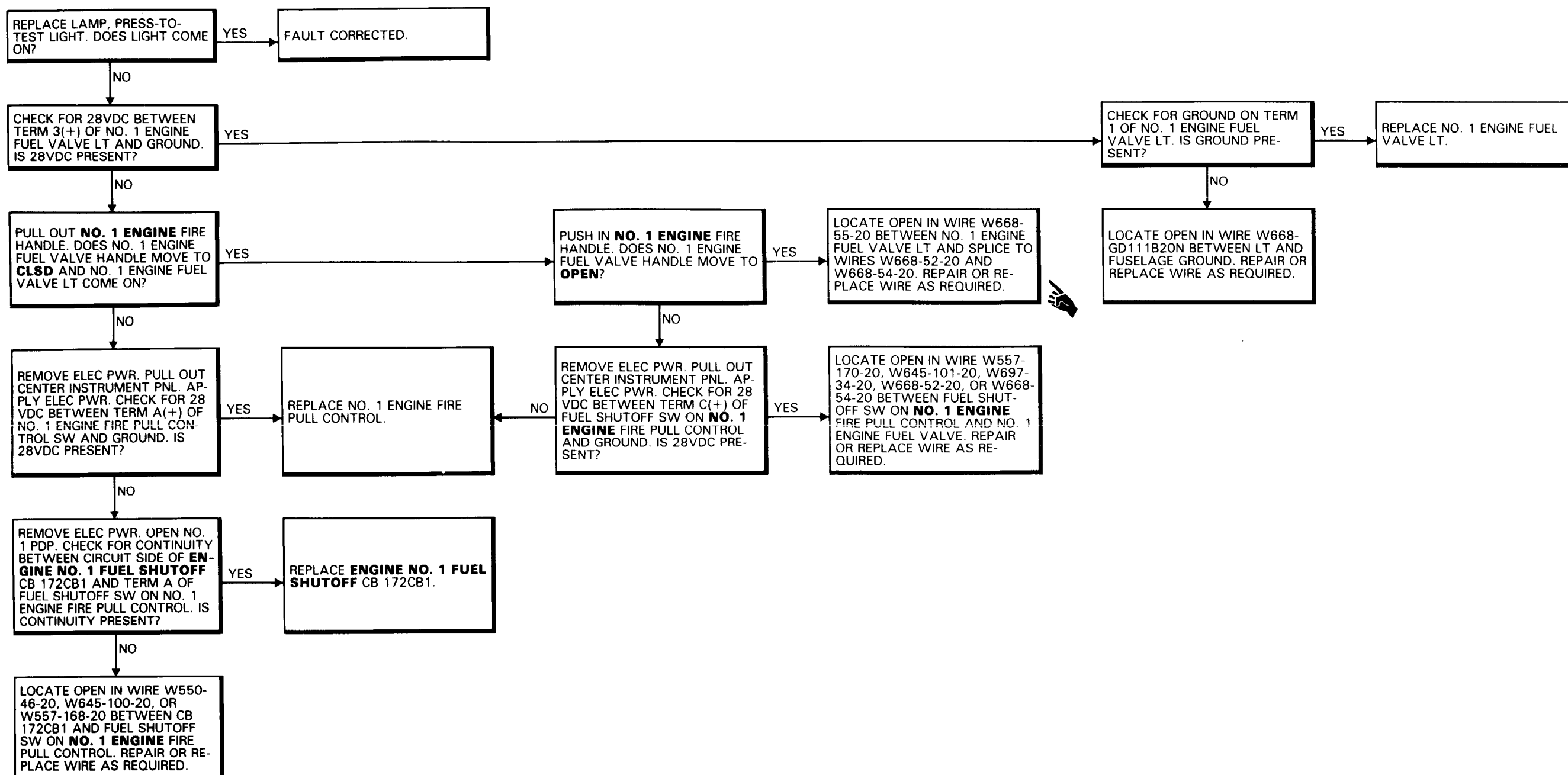

10-1.8 NO. 2 ENGINE FUEL VALVE LIGHT DOES NOT COME ON DURING PRESS-TO-TEST

FAULT ISOLATION PROCEDURE

INITIAL SETUP

Applicable Configurations:

All

Tools:

Electrical Repairer's Tool Kit,
NSN 5180-00-323-4915
Multimeter

Materials:

None

Personnel Required:

68F10 Aircraft Electrician
68F20 Aircraft Electrician

References:

TM 55-1520-240-23

Equipment Condition:

TM 55-1520-240-23:
Battery Connected
Electrical Power On
Hydraulic Power Off

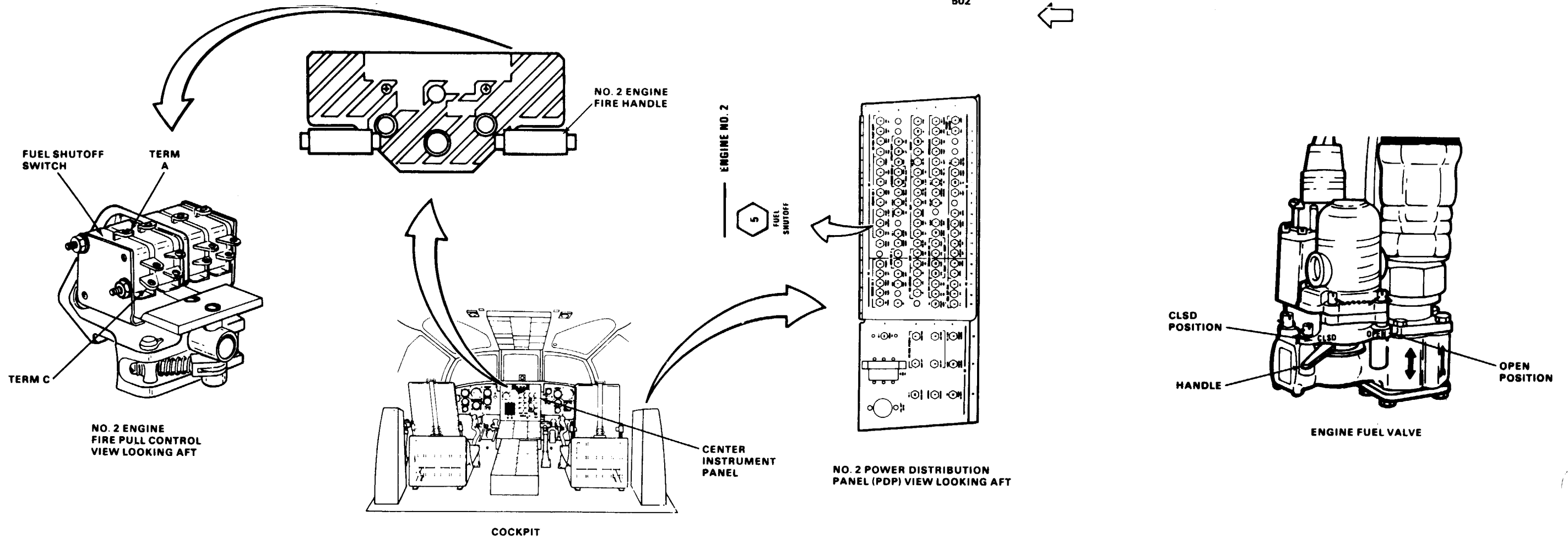
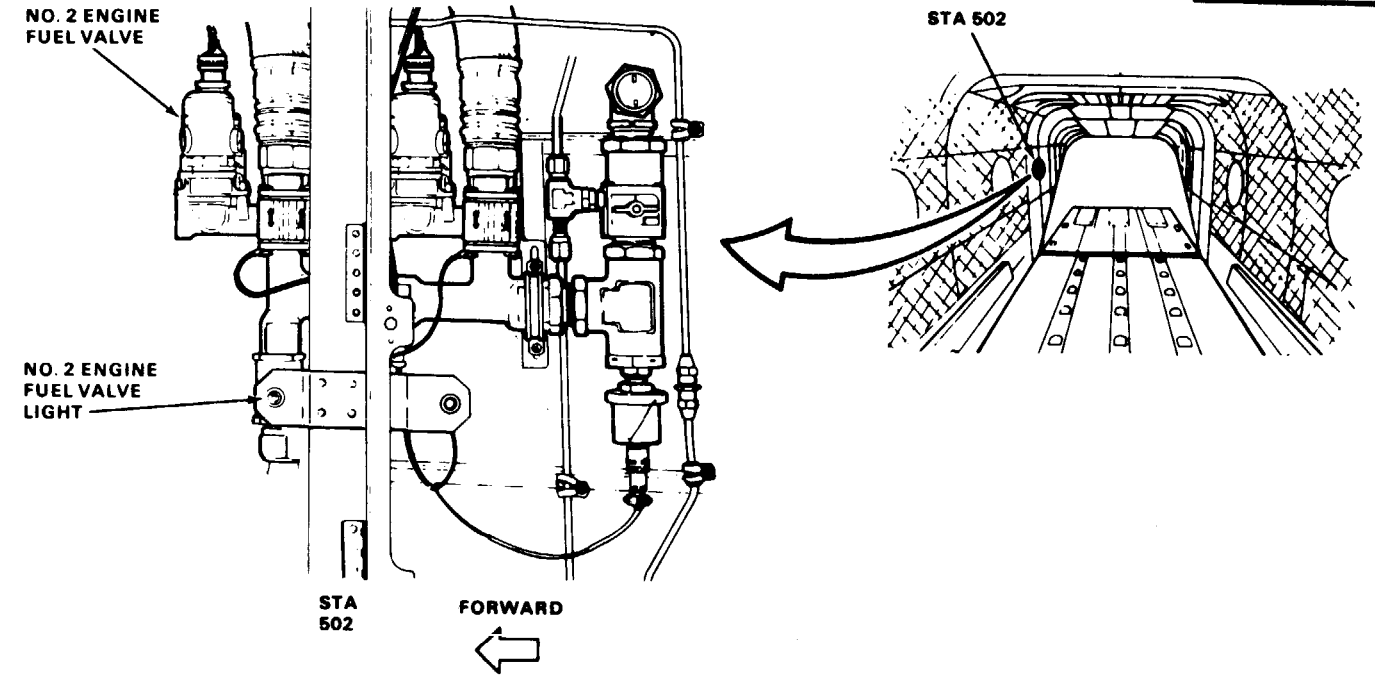

10-1.8 NO. 2 ENGINE FUEL VALVE LIGHT DOES NOT COME ON DURING PRESS-TO-TEST (Continued)

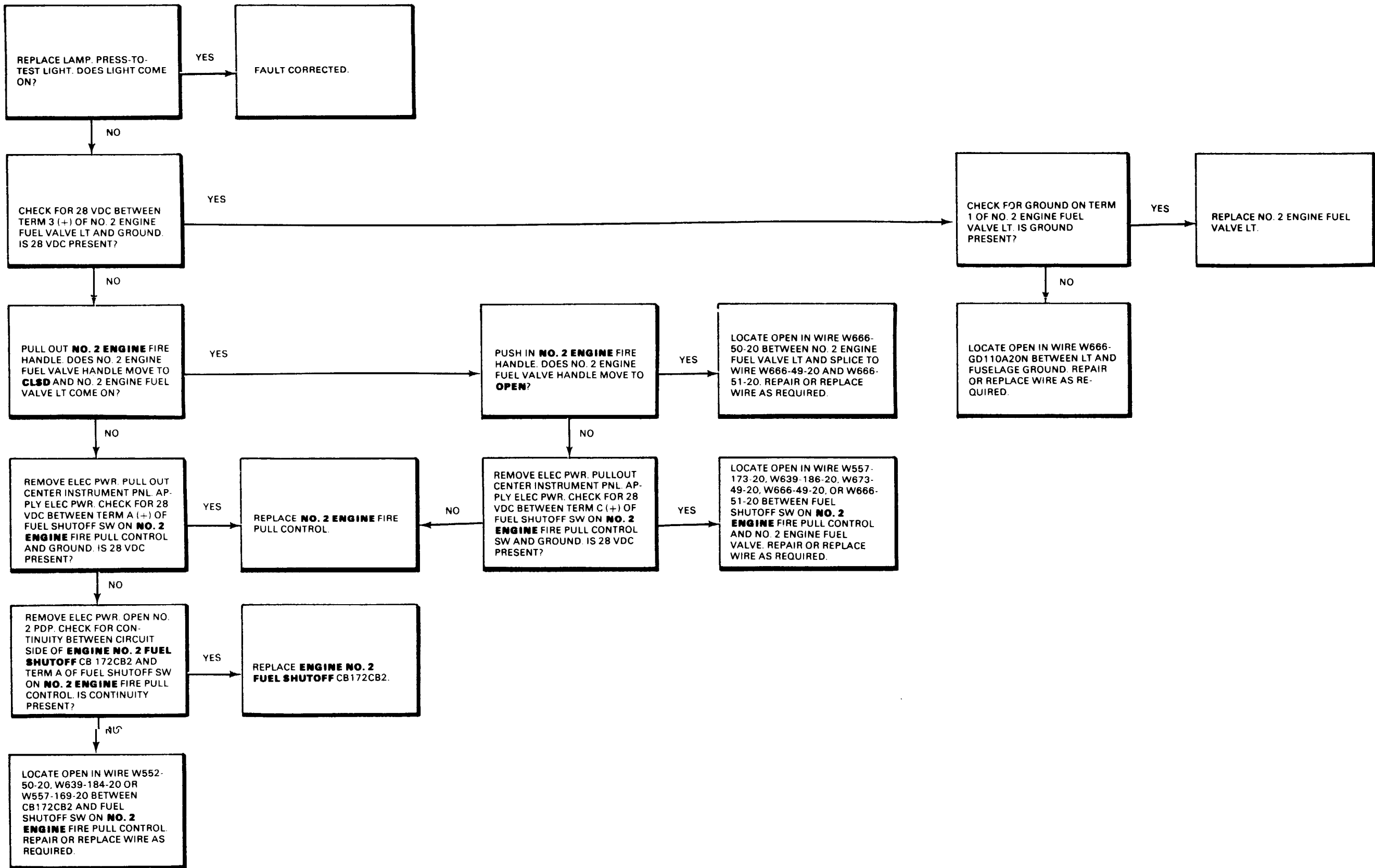

END OF TASK

10-1.9 ENGINE FUEL VALVE HANDLE IS NOT AT OPEN
WITH FIRE HANDLE IN

FAULT ISOLATION PROCEDURE

INITIAL SETUP

Personnel Required:
68F20 Aircraft Electrician

Applicable Configurations:
All

References:
TM 55-1520-240-23

Tools:
Electrical Repairer's Tool Kit,
NSN 5180-00-323-4915
Multimeter

Equipment Condition:
TM 55-1520-240-23:
Battery Connected
Electrical Power On
Hydraulic Power Off

Materials:
None

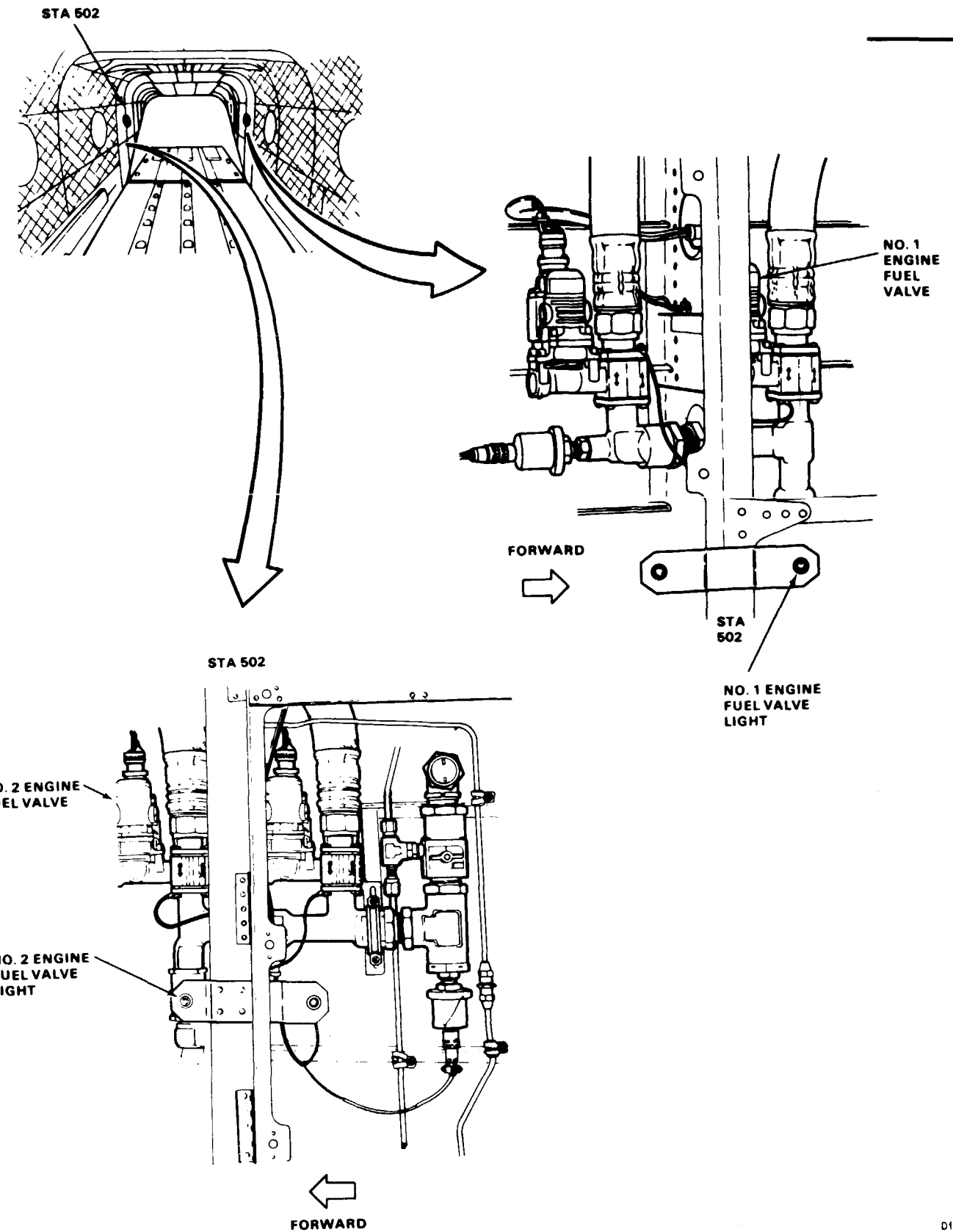

45x54

D145-5070-SPA

GO TO NEXT PAGE

10-1.9 ENGINE FUEL VALVE HANDLE IS NOT AT OPEN WITH FIRE HANDLE IN (Continued)

10-1.9

NO. 1 ENGINE FUEL VALVE HANDLE IS NOT AT OPEN WITH NO. 1 ENGINE FIRE HANDLE IN

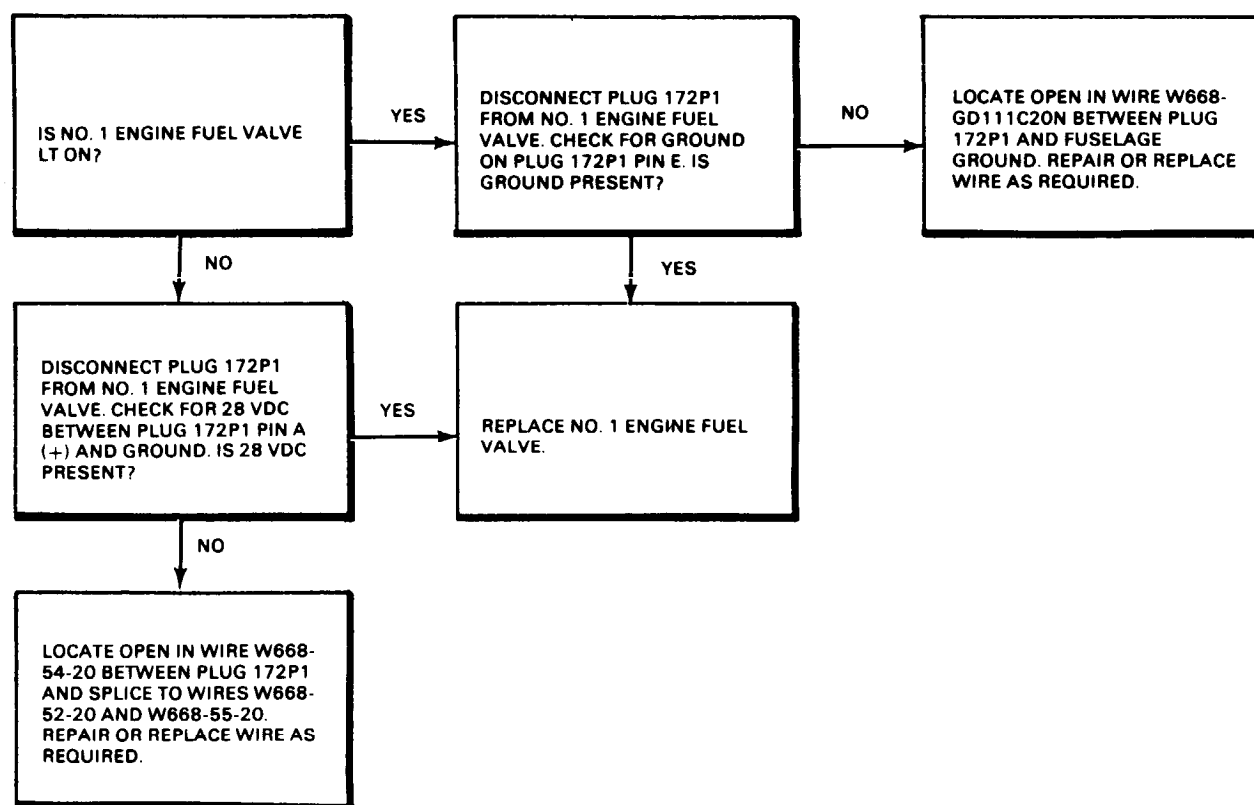

NO. 2 ENGINE FUEL VALVE HANDLE IS NOT AT OPEN WITH NO. 2 ENGINE FIRE HANDLE IN

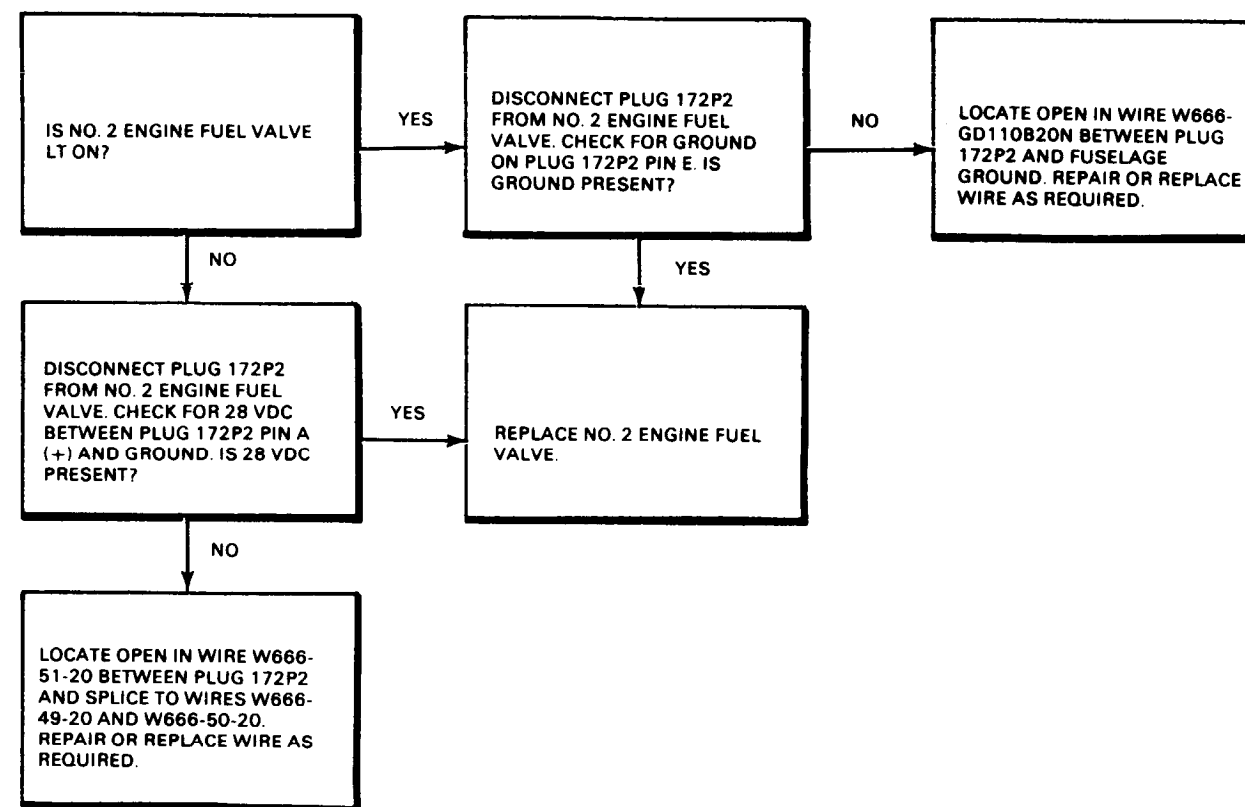

END OF TASK

10-1.10 ENGINE FUEL VALVE LIGHT DOES NOT COME ON,
VALVE OPERATION NORMAL

FAULT ISOLATION PROCEDURE

INITIAL SETUP

Personnel Required:
68F20 Aircraft Electrician

Applicable Configurations:
All

References:
TM 55-1520-240-23

Tools:
Electrical Repairer's Tool Kit,
NSN 5180-00-323-4915
Multimeter

Equipment Condition:
TM 55-1520-240-23:
Battery Connected
Electrical Power On
Hydraulic Power Off

Materials:
None

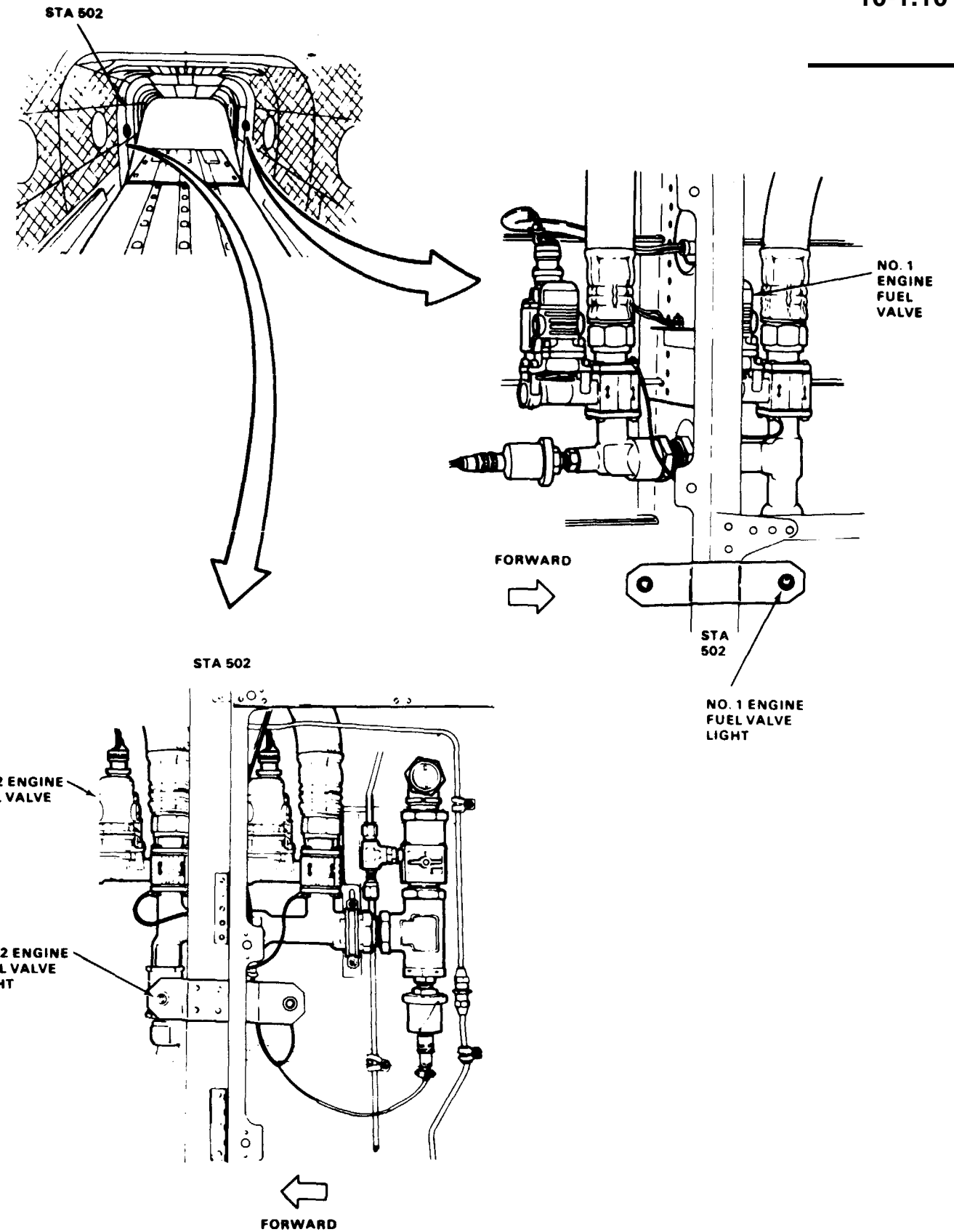

10-1.10 ENGINE FUEL VALVE LIGHT DOES NOT COME ON, VALVE OPERATION NORMAL (Continued)

10-1.10

NO. 1 ENGINE FUEL VALVE LIGHT DOES NOT COME ON, VALVE OPERATION NORMAL

NO. 2 ENGINE FUEL VALVE LIGHT DOES NOT COME ON, VALVE OPERATION NORMAL

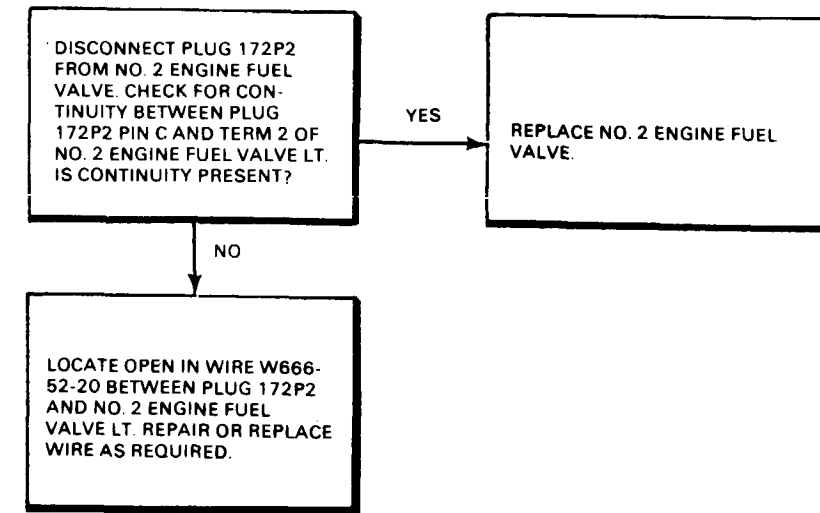
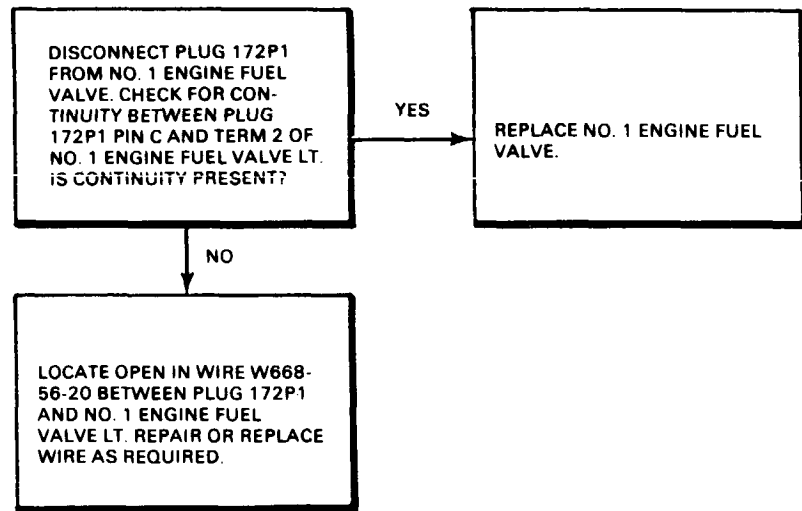

END OF TASK

10-1.11 ENGINE FUEL VALVE HANDLE IS NOT AT CLSD WITH FIRE HANDLE PULLED

FAULT ISOLATION PROCEDURE

INITIAL SETUP

Applicable Configurations:

All

Tools:

Electrical Repairer's Tool Kit,
NSN 5180-00-323-4915
Multimeter

Materials:

None

Personnel Required:

68F20 Aircraft Electrician

References:

TM 55-1520-240-23

Equipment Condition:

TM 55-1520-240-23:
Battery Connected
Electrical Power On
Hydraulic Power Off

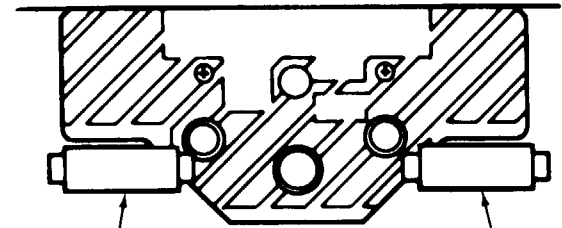
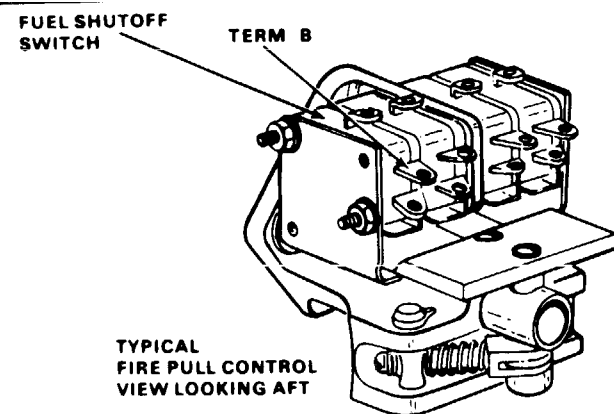

NO. 1 ENGINE FIRE HANDLE

NO. 2 ENGINE FIRE HANDLE

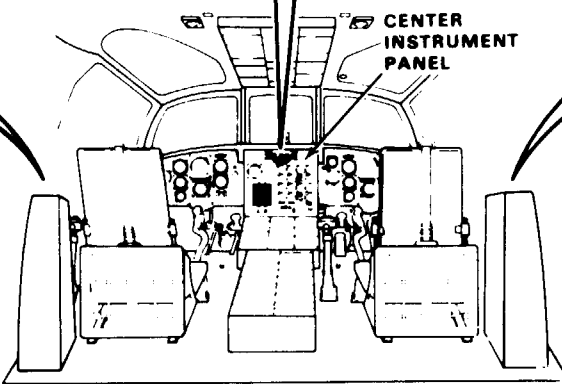

COCKPIT

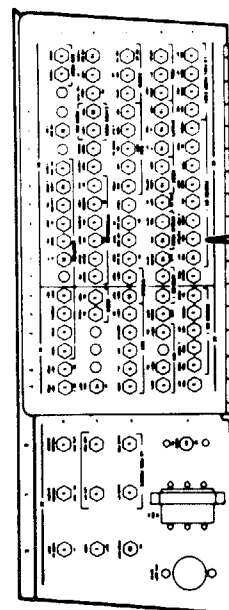

NO. 1 POWER DISTRIBUTION PANEL (PDP) VIEW LOOKING AFT

FUEL SHUTOFF SWITCH



ENGINE NO. 1

ENGINE NO. 2



FUEL SHUTOFF SWITCH

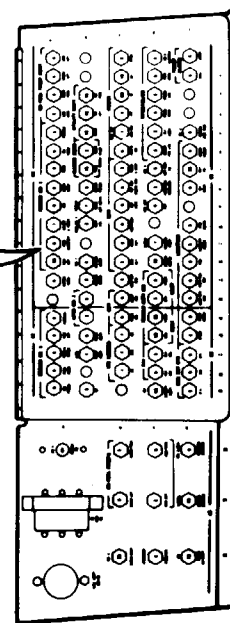

NO. 2 POWER DISTRIBUTION PANEL (PDP) VIEW LOOKING AFT

NO. 2 ENGINE FUEL VALVE

NO. 2 ENGINE FUEL VALVE LT

STA 502

FORWARD

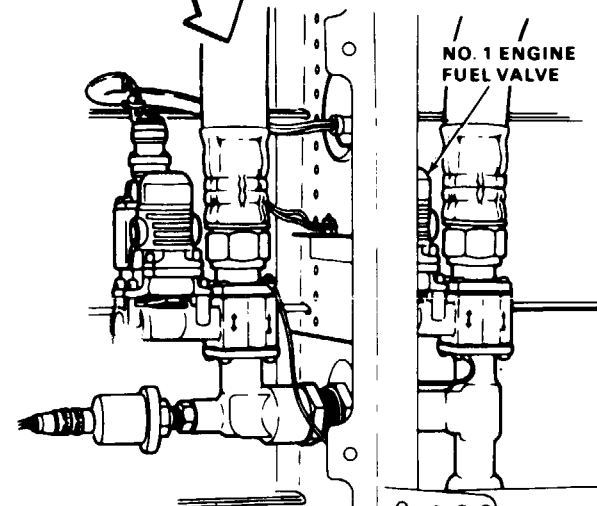
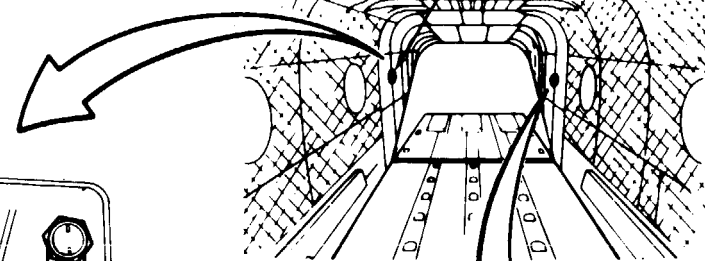

FORWARD

STA 502

NO. 1 ENGINE FUEL VALVE LT

10-1.11 ENGINE FUEL VALVE HANDLE IS NOT AT CLSD WITH FIRE HANDLE PULLED (Continued)

10-1.11

NO. 1 ENGINE FUEL VALVE HANDLE IS NOT AT CLSD WITH NO. 1 ENGINE FIRE HANDLE PULLED

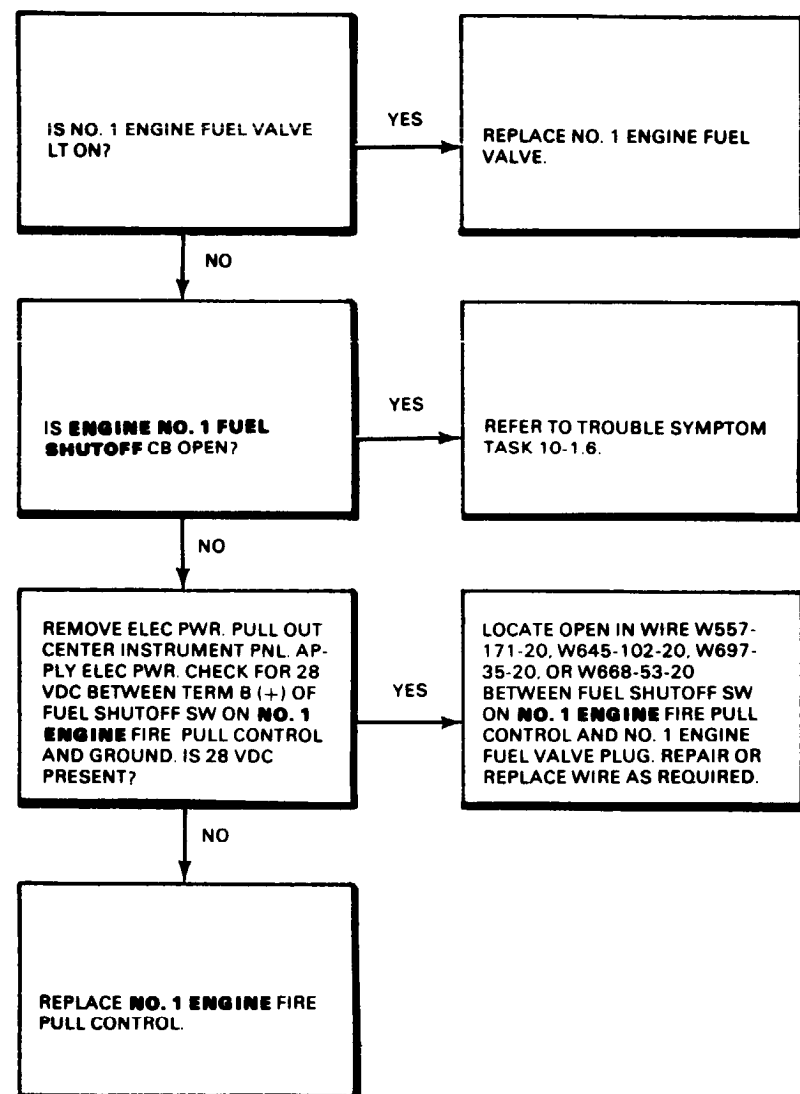

NO. 2 ENGINE FUEL VALVE HANDLE IS NOT AT CLSD WITH NO. 2 ENGINE FIRE HANDLE PULLED

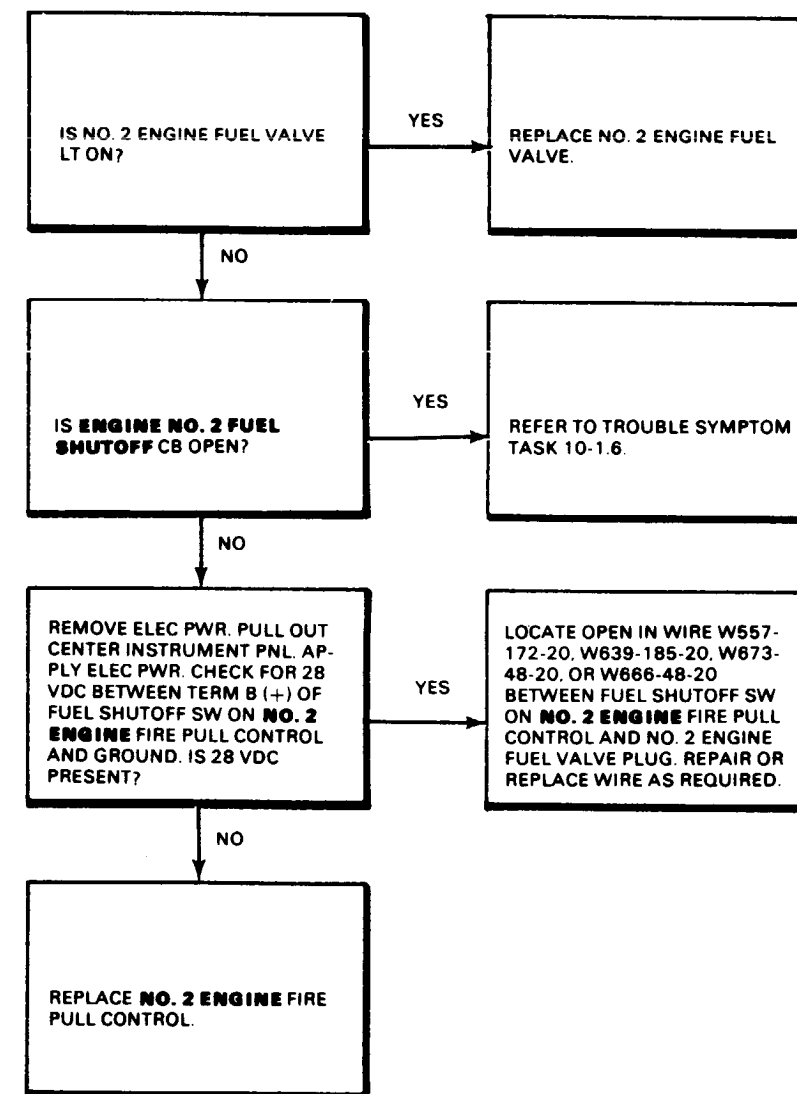

END OF TASK

10-1.12 LEFT CROSSFEED FUEL VALVE LIGHT DOES NOT COME ON DURING PRESS-TO-TEST

FAULT ISOLATION PROCEDURE

INITIAL SETUP

Applicable Configurations:

All

Tools:

Electrical Repairer's Tool Kit,
NSN 5180-00-323-4915
Multimeter

Materials:

None

Personnel Required:

68F10 Aircraft Electrician
68F20 Aircraft Electrician

References:

TM 55-1520-240-23

Equipment Condition:

TM 55-1520-240-23:
Battery Connected
Electrical Power On
Hydraulic Power Off

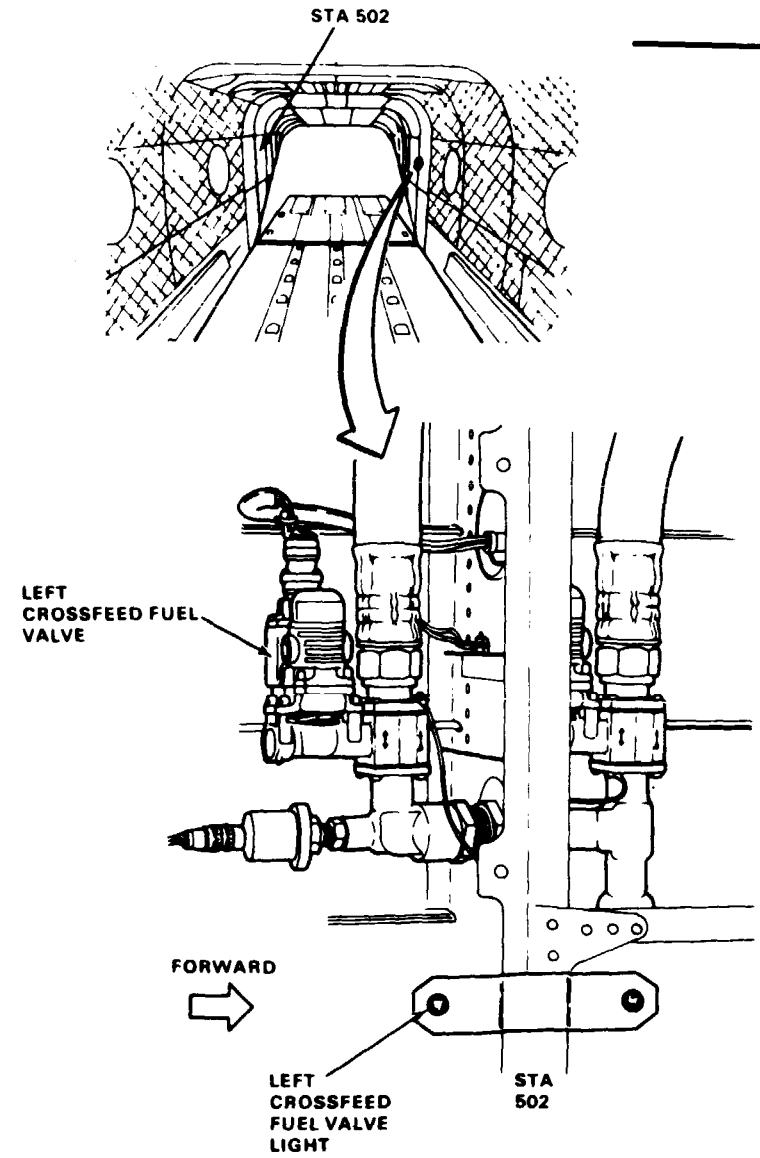
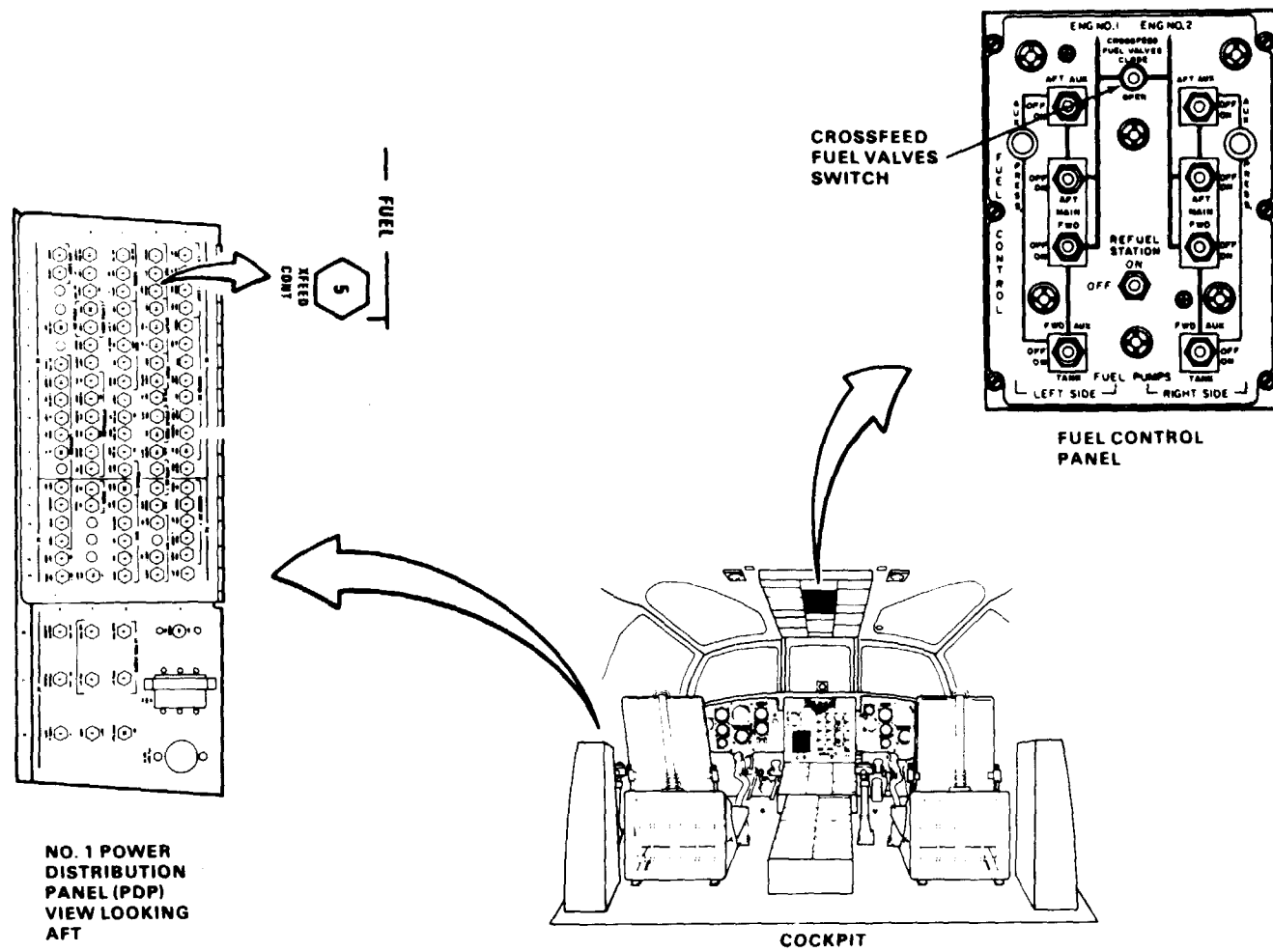

10-1.12 LEFT CROSSFEED FUEL VALVE LIGHT DOES NOT COME ON DURING PRESS-TO-TEST (Continued)

10-1.12

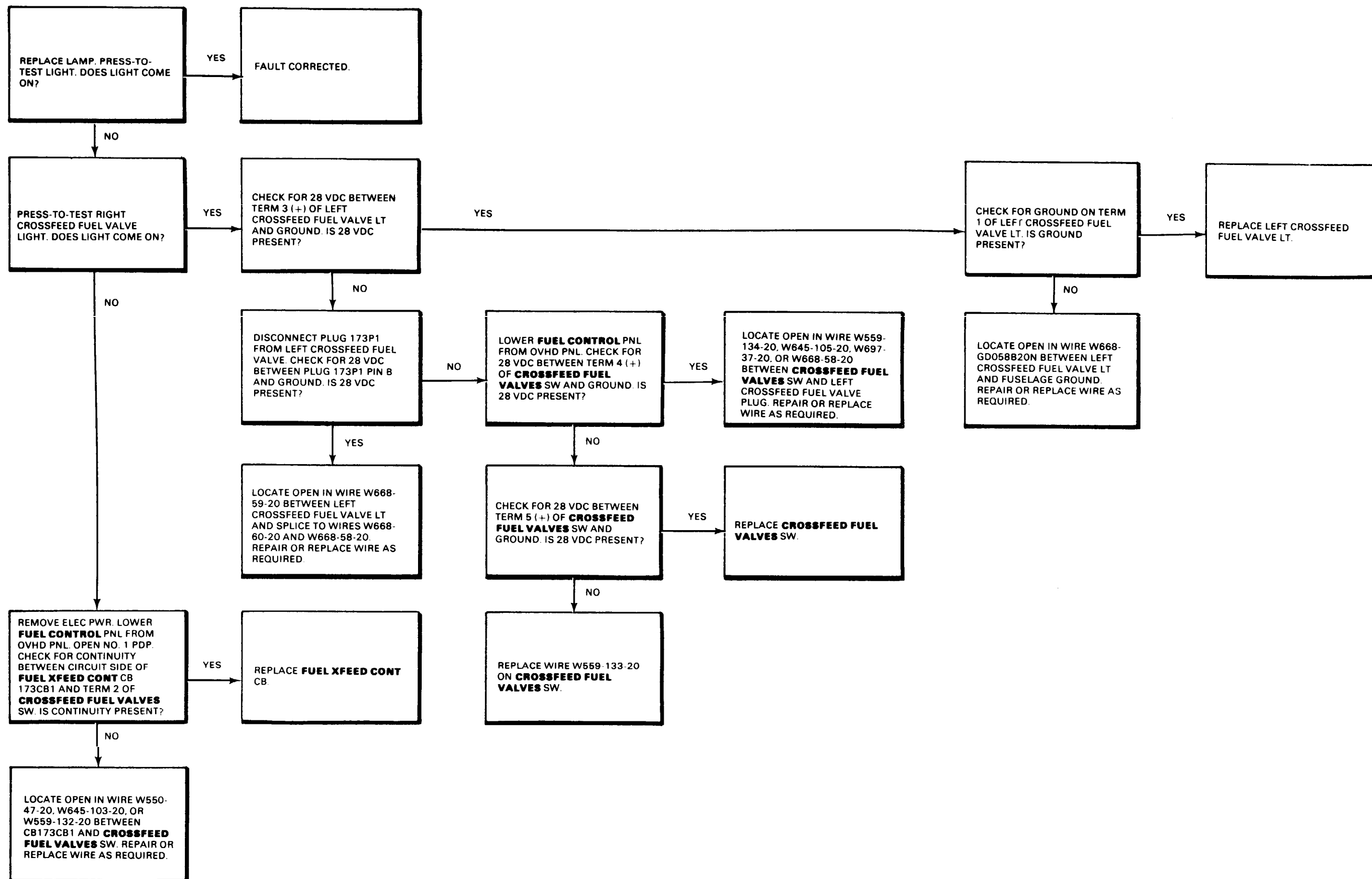

END OF TASK

10-1.13 RIGHT CROSSFEED FUEL VALVE LIGHT DOES NOT COME ON DURING PRESS-TO-TEST

FAULT ISOLATION PROCEDURE

INITIAL SETUP

Personnel Required:
68F20 Aircraft Electrician

Applicable Configurations:
All

References:
TM 55-1520-240-23

Tools:
Electrical Repairer's Tool Kit,
NSN 5180-00-323-4915
Multimeter

Equipment Condition:
TM 55-1520-240-23:
Battery Connected
Electrical Power On
Hydraulic Power Off

Materials:
None

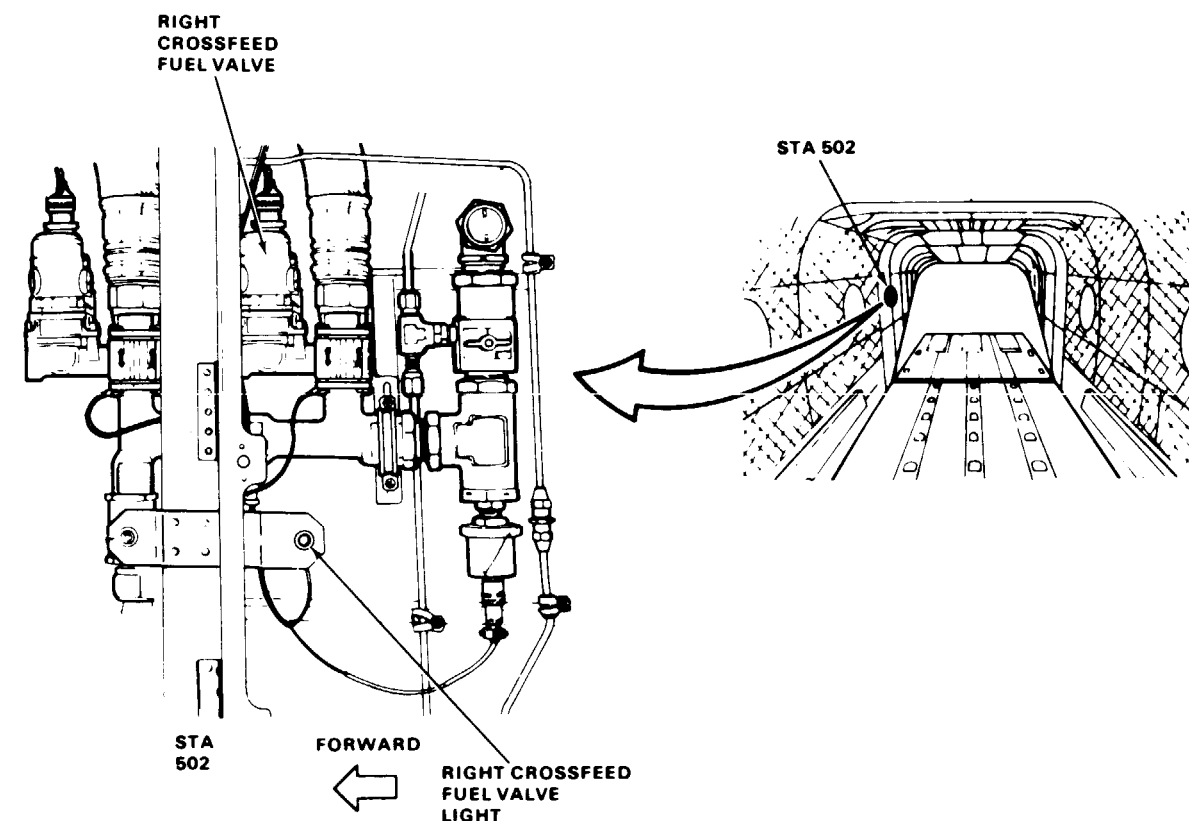
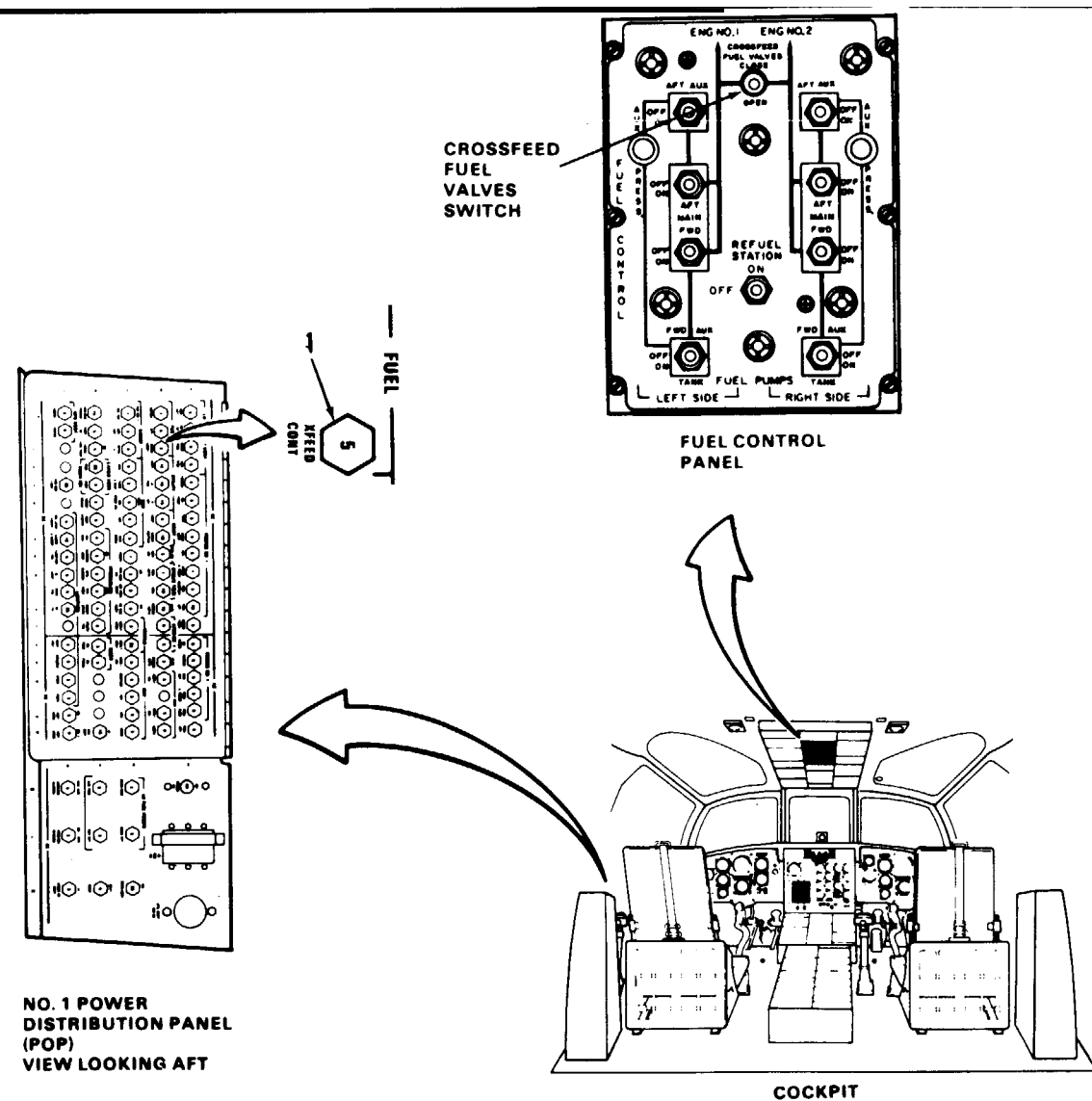

10-1.13 RIGHT CROSSFEED FUEL VALVE LIGHT DOES NOT COME ON DURING PRESS-TO-TEST (Continued)

10-1.13

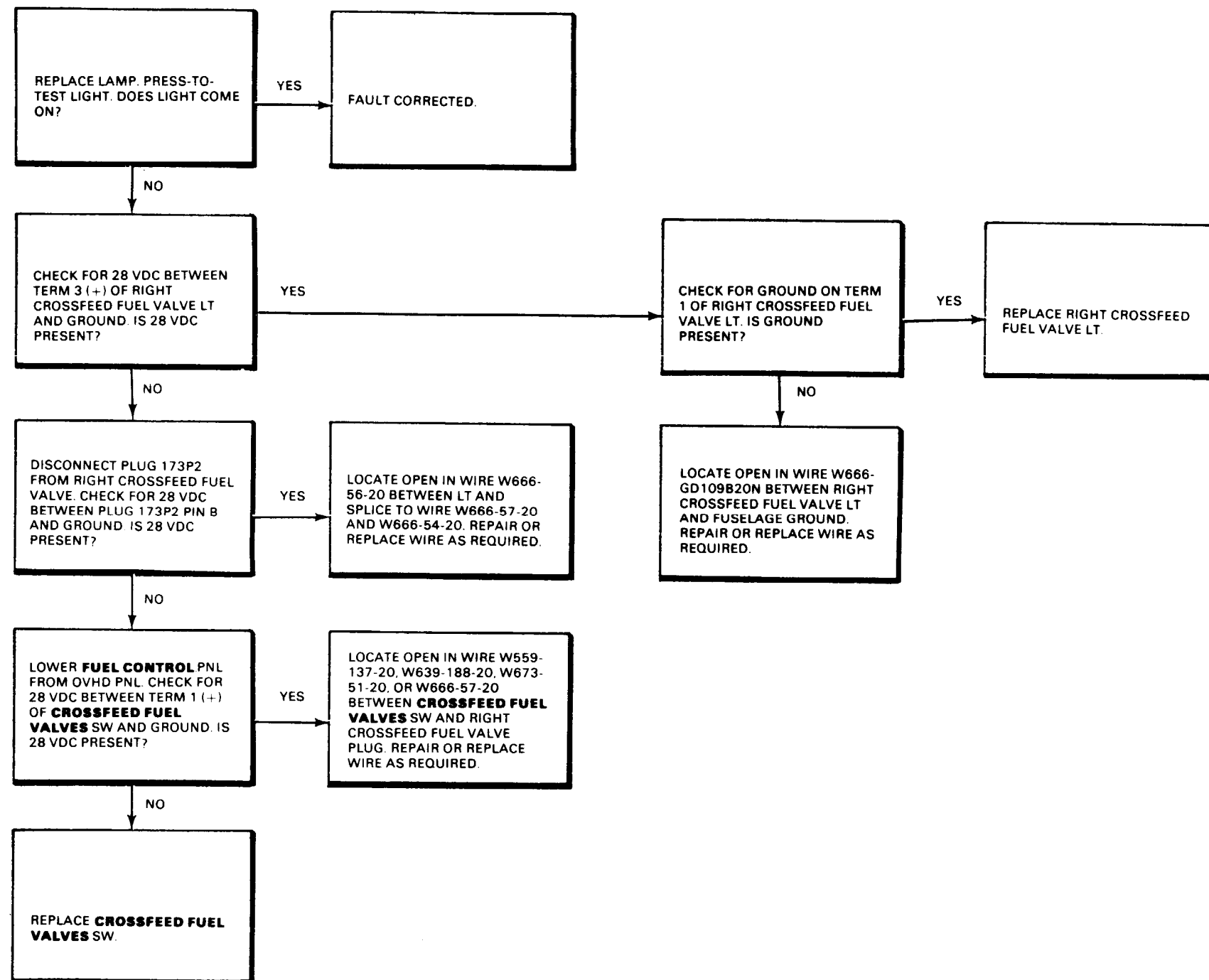

END OF TASK

10-1.14 CROSSFEED FUEL VALVE HANDLE IS NOT AT OPEN WITH CROSSFEED FUEL VALVES SWITCH AT OPEN

FAULT ISOLATION PROCEDURE

INITIAL SETUP

Applicable Configurations:

All

Tools:

Electrical Repairer's Tool Kit,
NSN 5180-00-323-4915
Multimeter

Materials:

None

Personnel Required:

68F20 Aircraft Electrician

References:

TM 55-1520-240-23

Equipment Condition:

TM 55-1520-240-23:
Battery Connected
Electrical Power On
Hydraulic Power Off

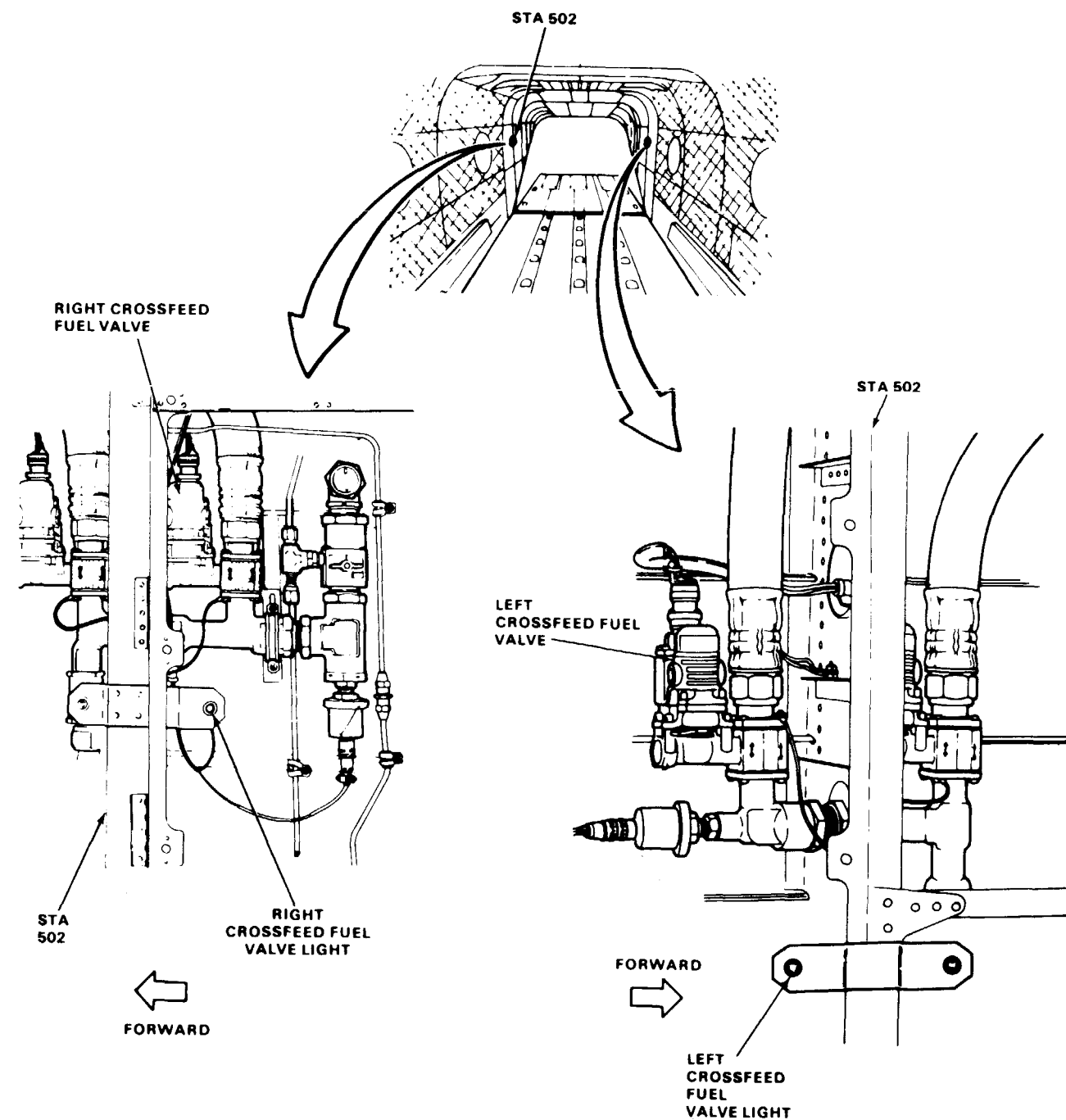
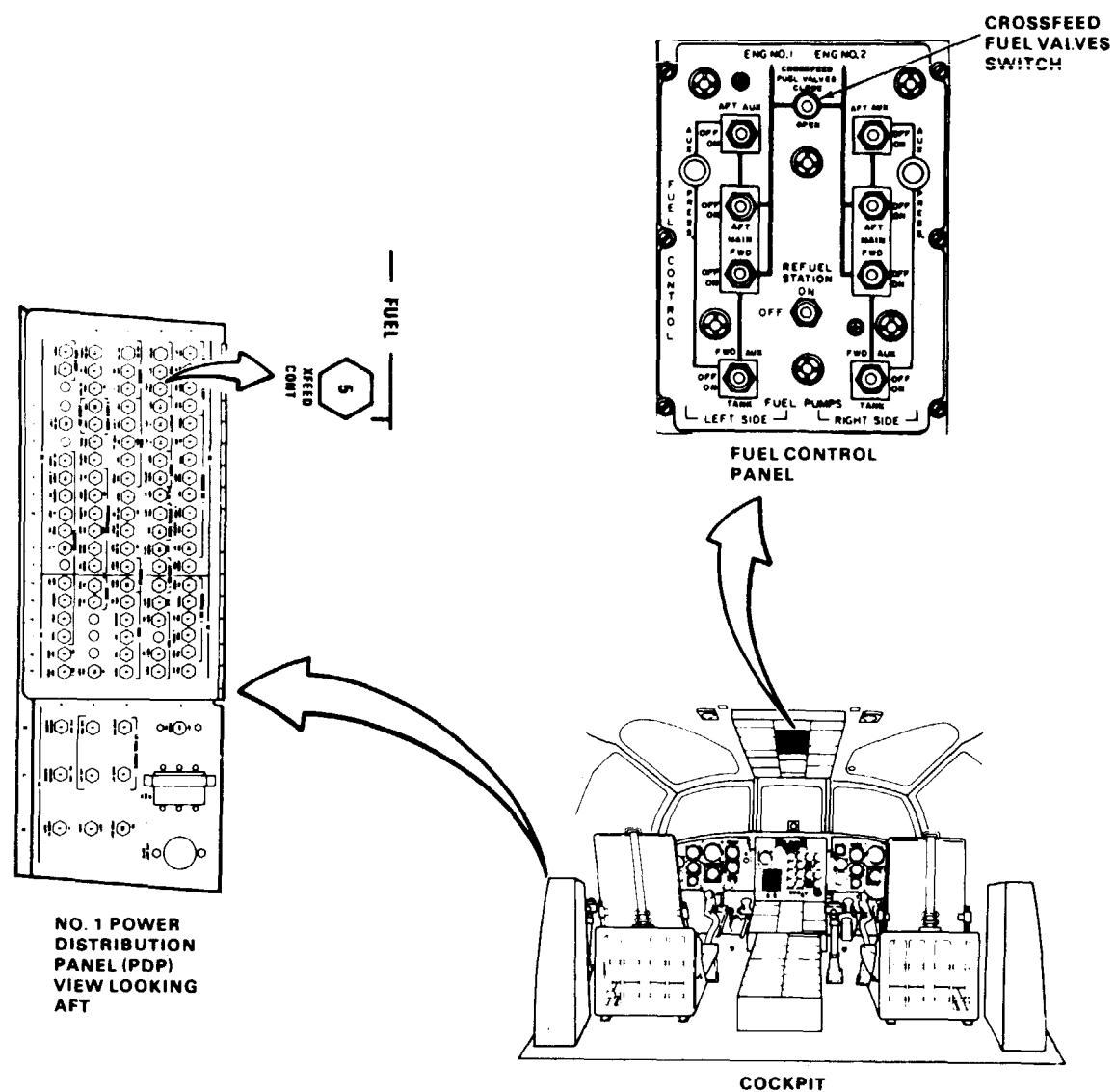

0145-5075-SPA

GO TO NEXT PAGE

10-1.14 CROSSFEED FUEL VALVE HANDLE IS NOT AT OPEN WITH CROSSFEED FUEL VALVES SWITCH AT OPEN (Continued)

LEFT CROSSFEED FUEL VALVE HANDLE IS NOT AT OPEN WITH CROSSFEED FUEL VALVES SWITCH AT OPEN

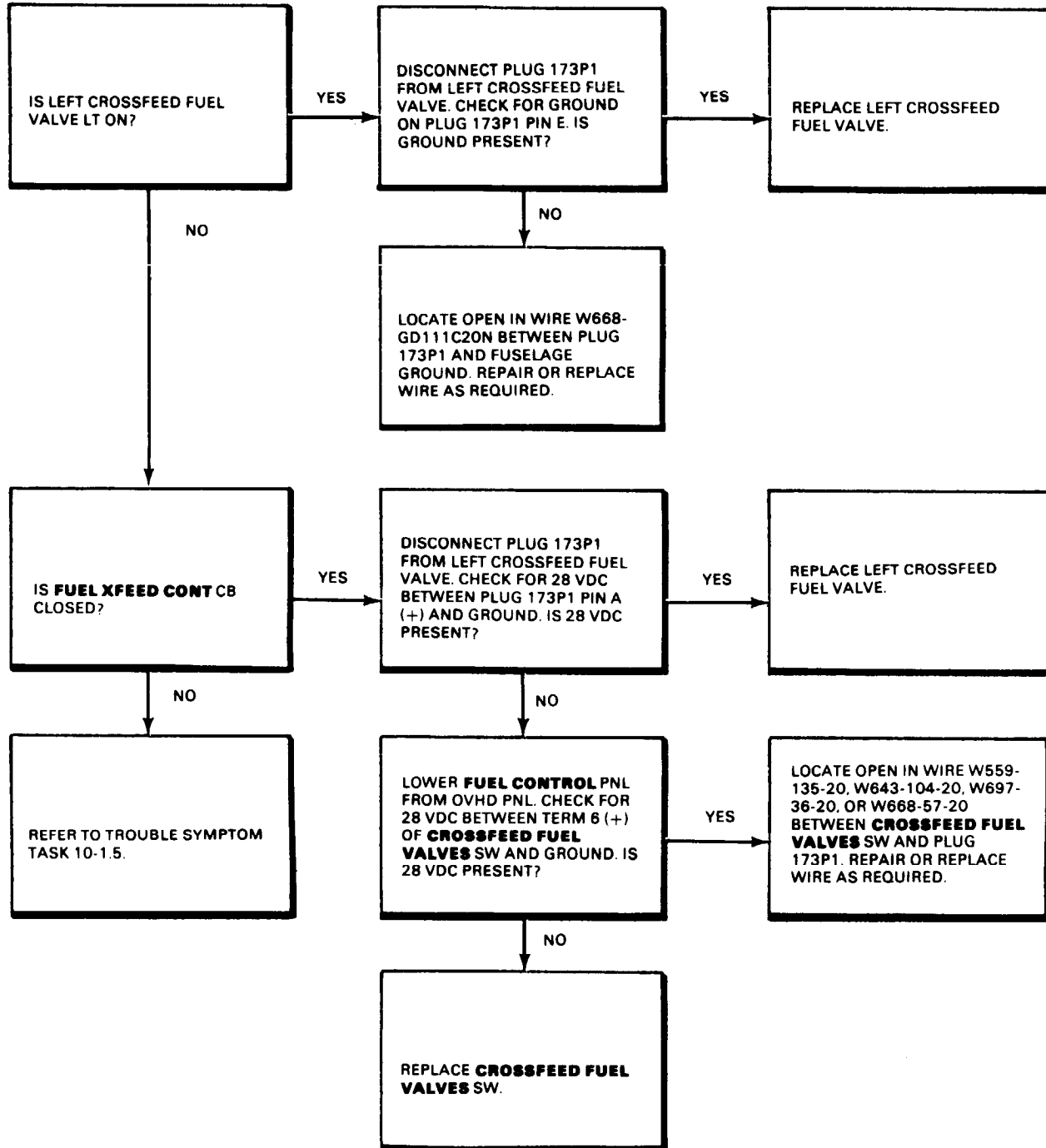

RIGHT CROSSFEED FUEL VALVE HANDLE IS NOT AT OPEN WITH CROSSFEED FUEL VALVES SWITCH AT OPEN

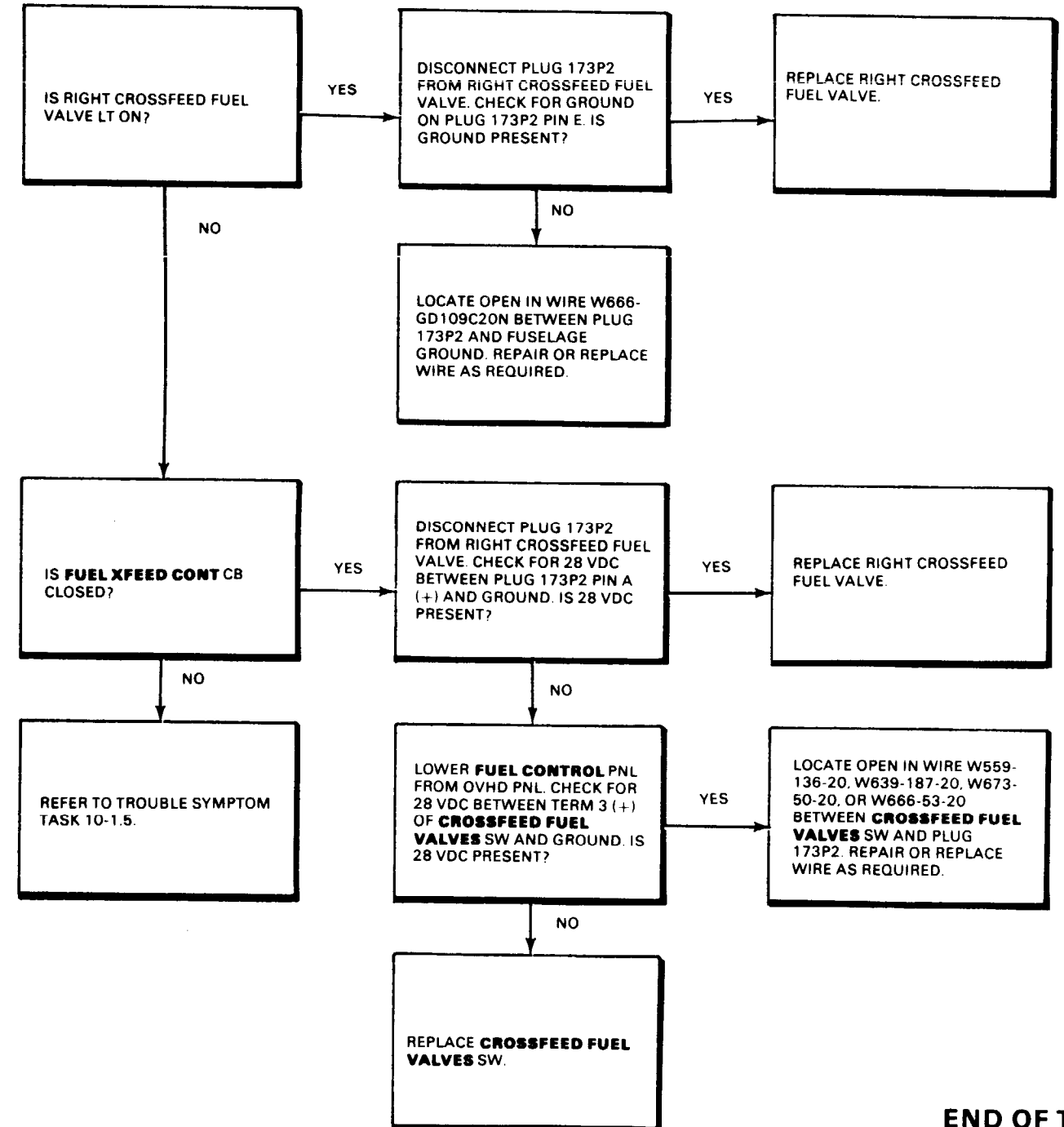

END OF TASK

10-1.15 CROSSFEED FUEL VALVE LIGHT DOES NOT COME ON, VALVE OPERATION NORMAL

FAULT ISOLATION PROCEDURE

INITIAL SETUP

Personnel Required:
68F20 Aircraft Electrician

Applicable Configurations:
All

References:
TM 55-1520-240-23

Tools:
Electrical Repairer's Tool Kit,
NSN 5180-00-323-4915
Multimeter

Equipment Condition:
TM 55-1520-240-23:
Battery Connected
Electrical Power On
Hydraulic Power Off

Materials:
None

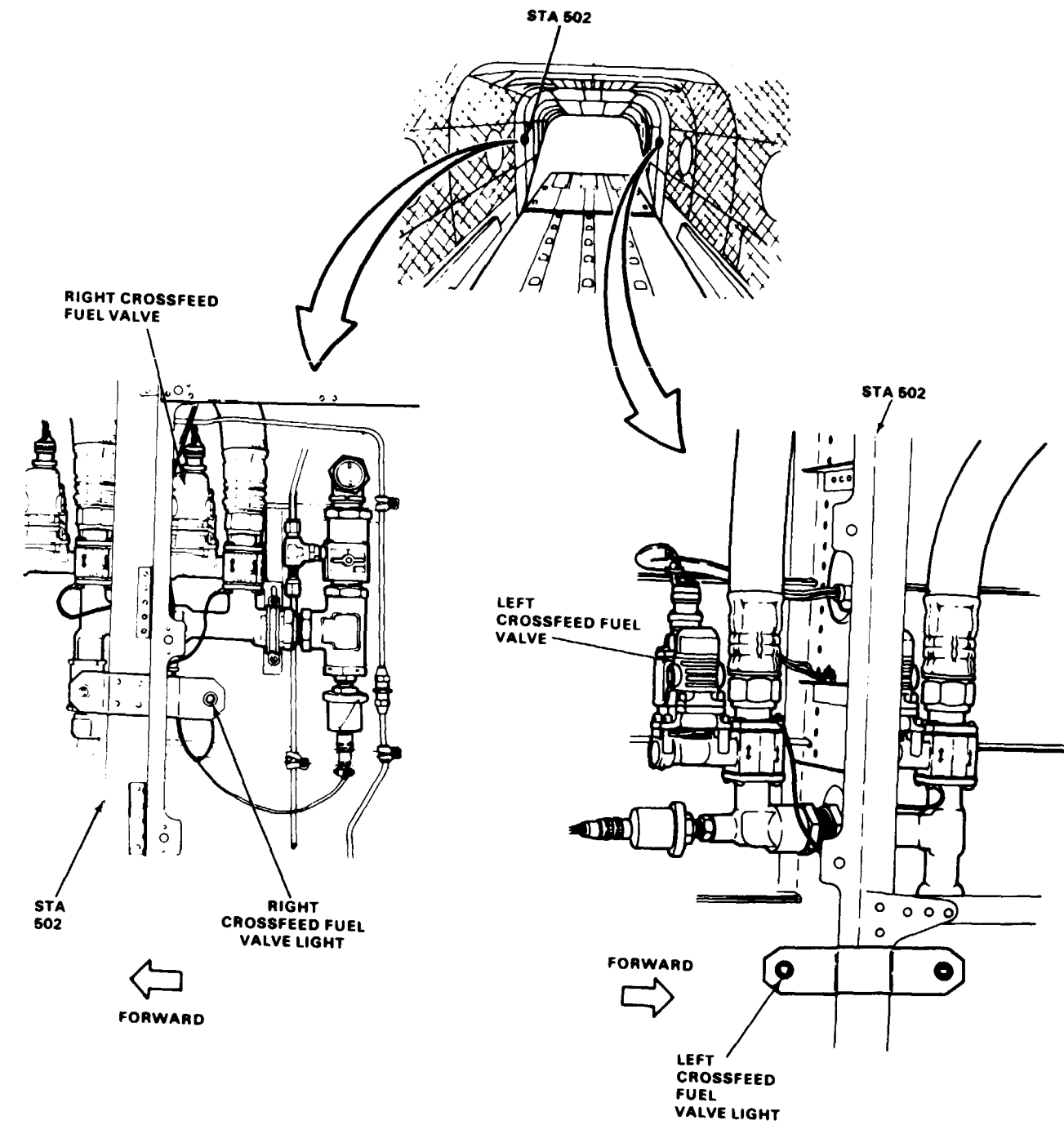
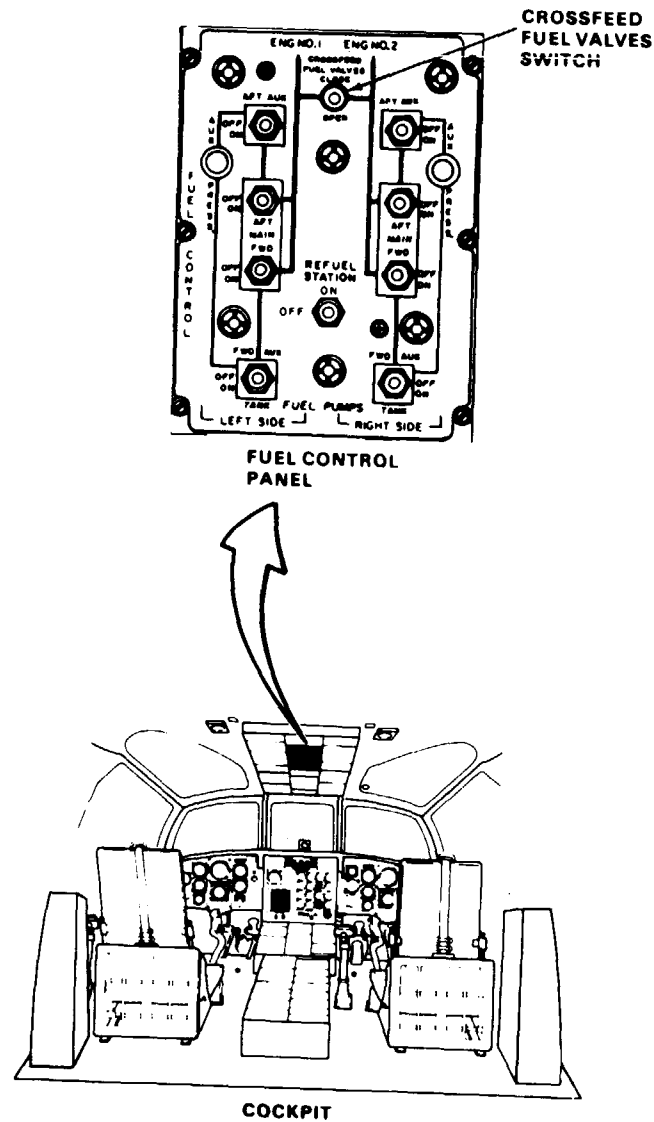

D145-3076-SPA

GO TO NEXT PAGE

10-1.15 CROSSFEED FUEL VALVE LIGHT DOES NOT COME ON, VALVE OPERATION NORMAL (Continued)

10-1.15

LEFT CROSSFEED FUEL VALVE LIGHT DOES NOT COME ON, VALVE OPERATION NORMAL

RIGHT CROSSFEED FUEL VALVE LIGHT DOES NOT COME ON, VALVE OPERATION NORMAL

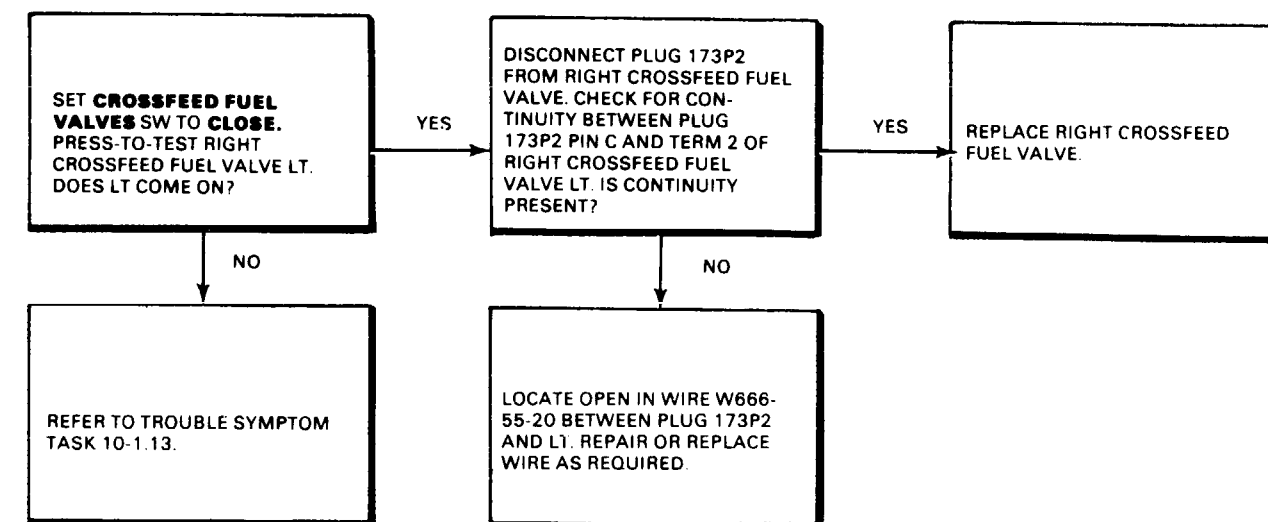
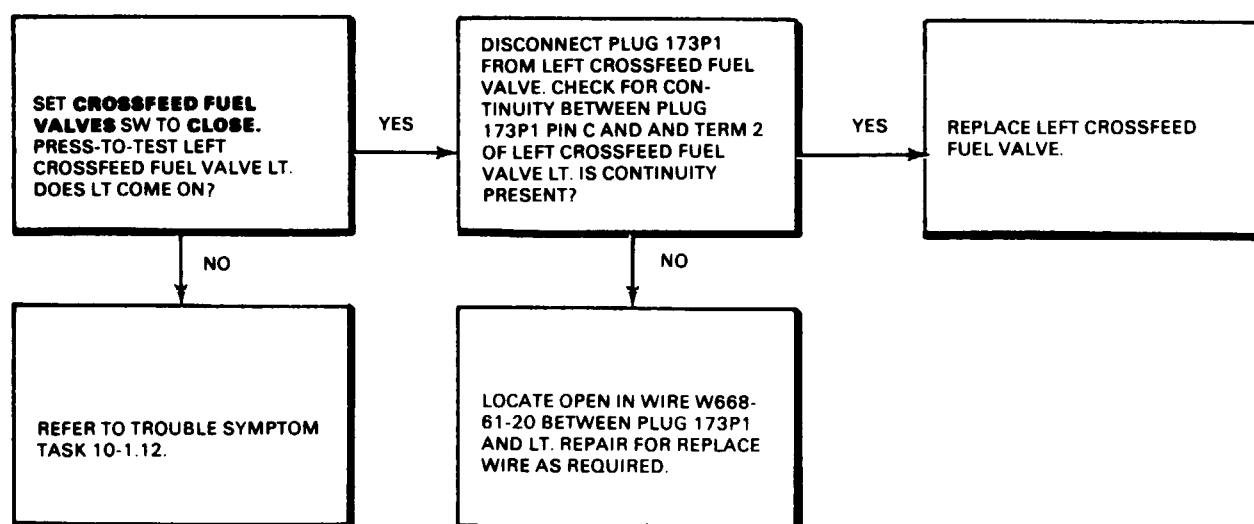

END OF TASK

10-1.16 CROSSFEED FUEL VALVE HANDLE IS NOT AT CLSD WITH CROSSFEED FUEL VALVES SWITCH AT CLOSE

FAULT ISOLATION PROCEDURE

INITIAL SETUP

Applicable Configurations:
All

Tools:
Electrical Repairer's Tool Kit,
NSN 5180-00-323-4915
Multimeter

Materials:
None

Personnel Required:
68F20 Aircraft Electrician

References:
TM 55-1520-240-23

Equipment Condition:
TM 55-1520-240-23:
Battery Connected
Electrical Power On
Hydraulic Power Off

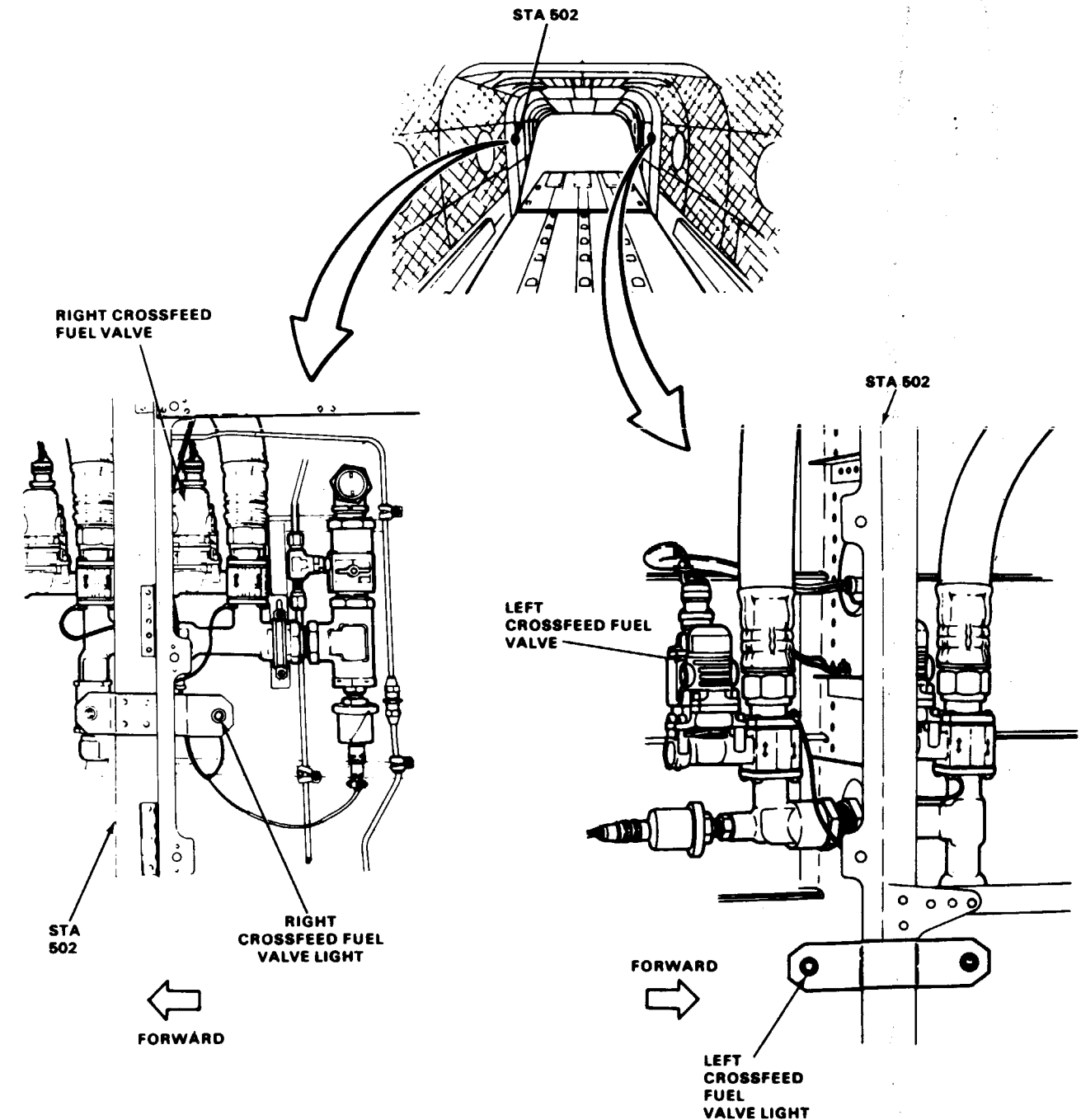
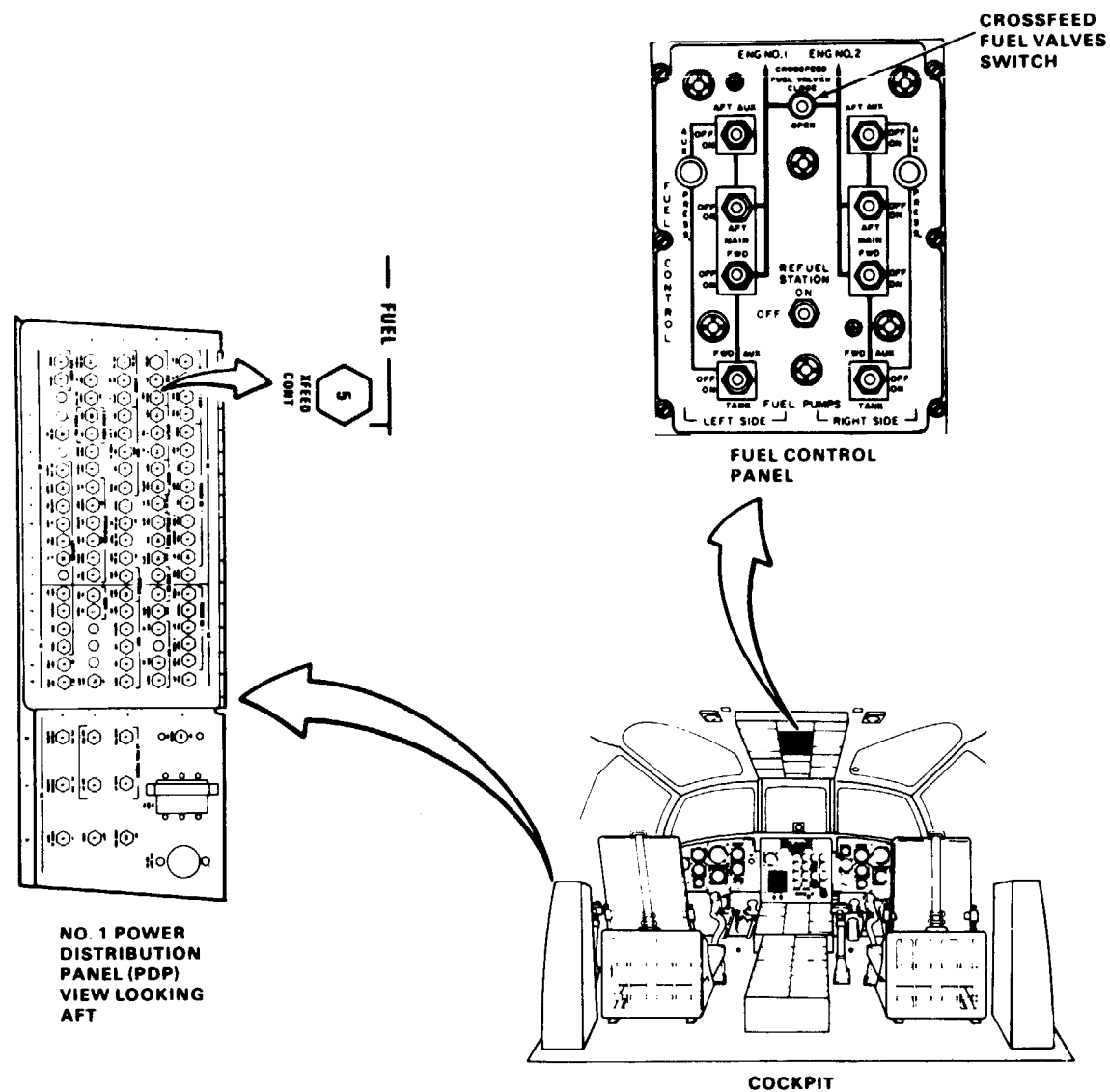

10-1.16 CROSSFEED FUEL VALVE HANDLE IS NOT AT CLSD WITH CROSSFEED FUEL VALVES SWITCH AT CLOSE (Continued)

10-1.16

LEFT CROSSFEED FUEL VALVE HANDLE IS NOT AT CLSD WITH CROSSFEED FUEL VALVES SWITCH AT CLOSE.

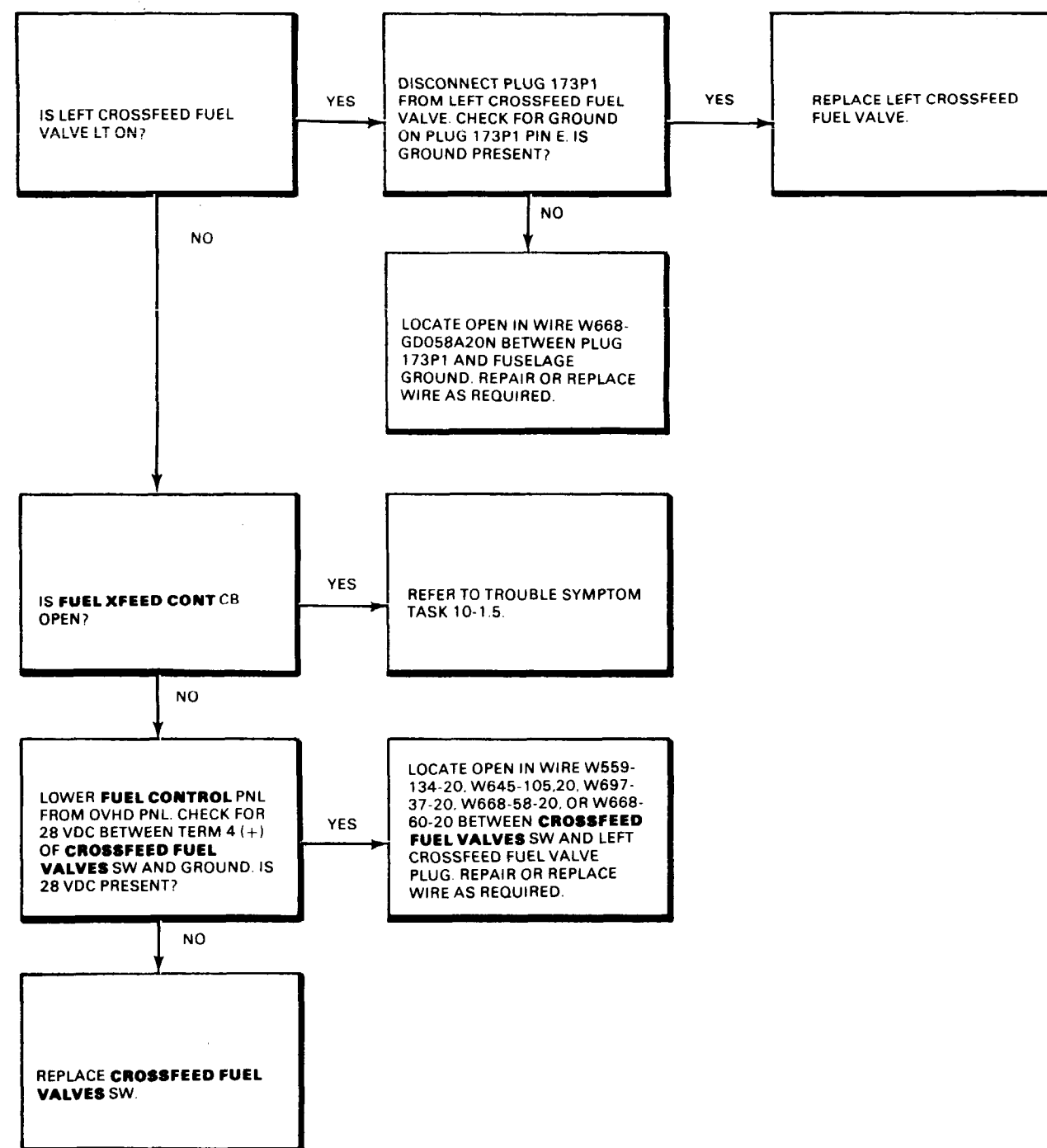

RIGHT CROSSFEED FUEL VALVE HANDLE IS NOT AT CLSD WITH CROSSFEED FUEL VALVES SWITCH AT CLOSE.

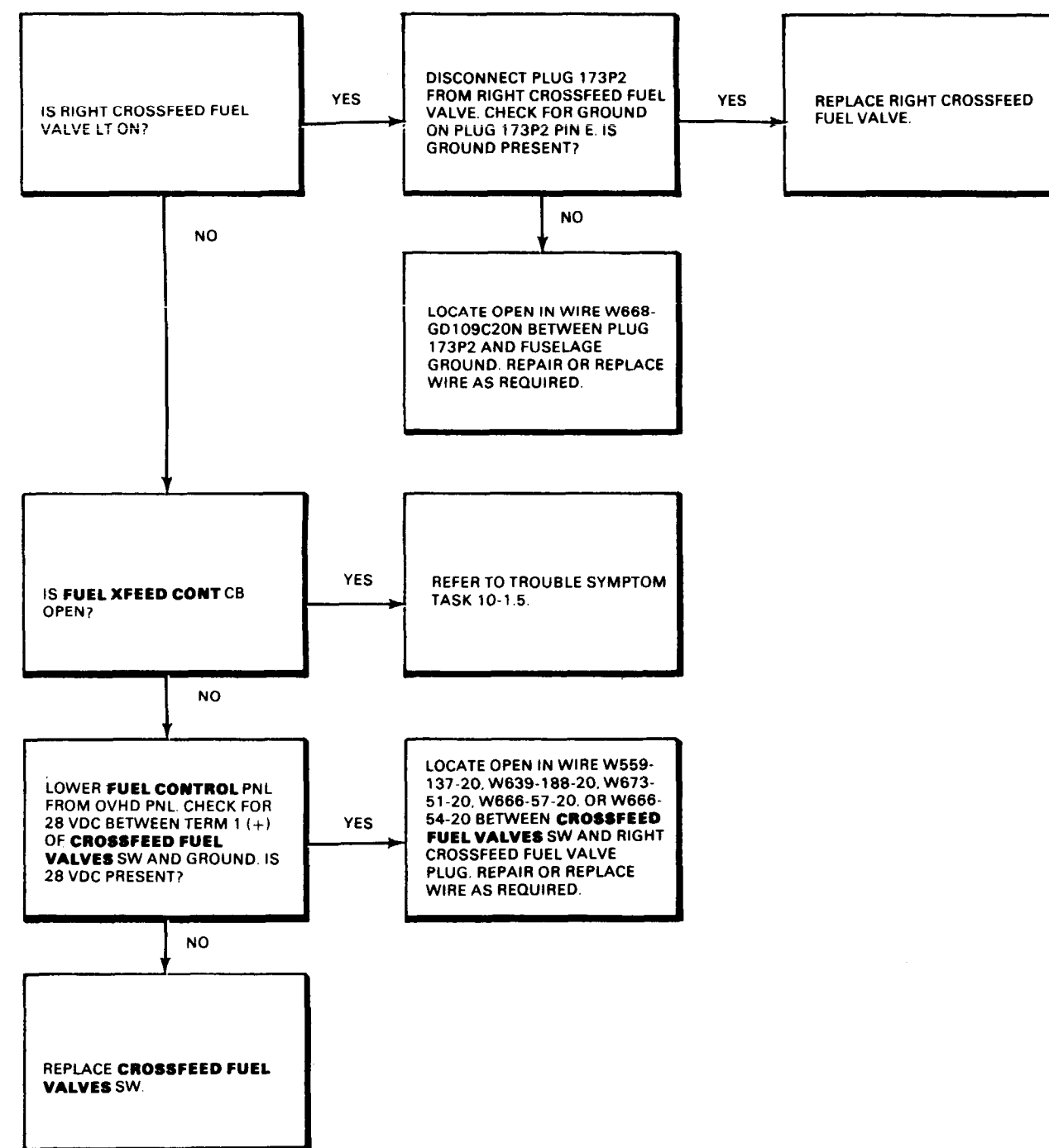

END OF TASK

10-2 FUEL BOOST PUMPS

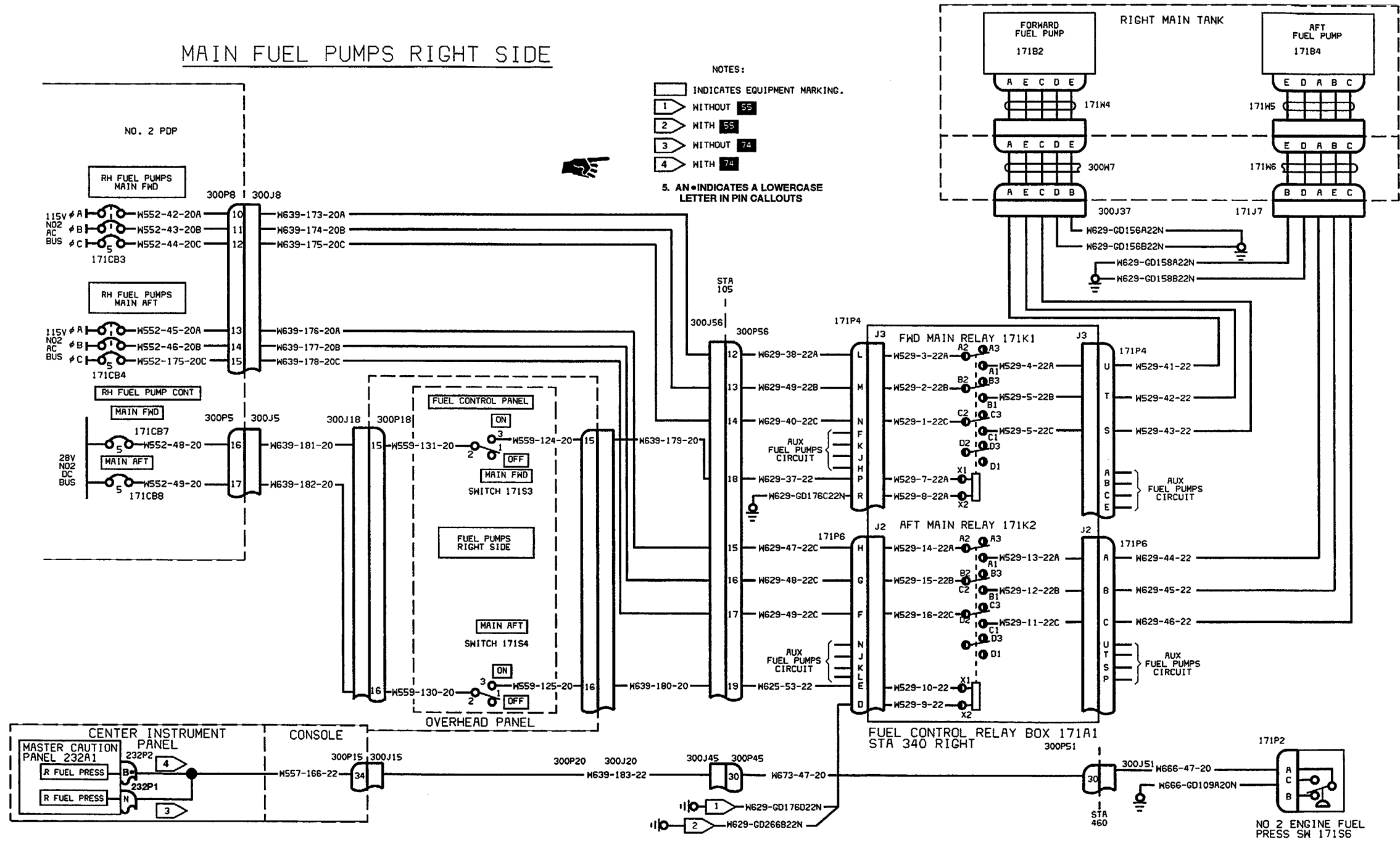

10-2.1 FUEL BOOST PUMPS WIRING DIAGRAM (Continued)

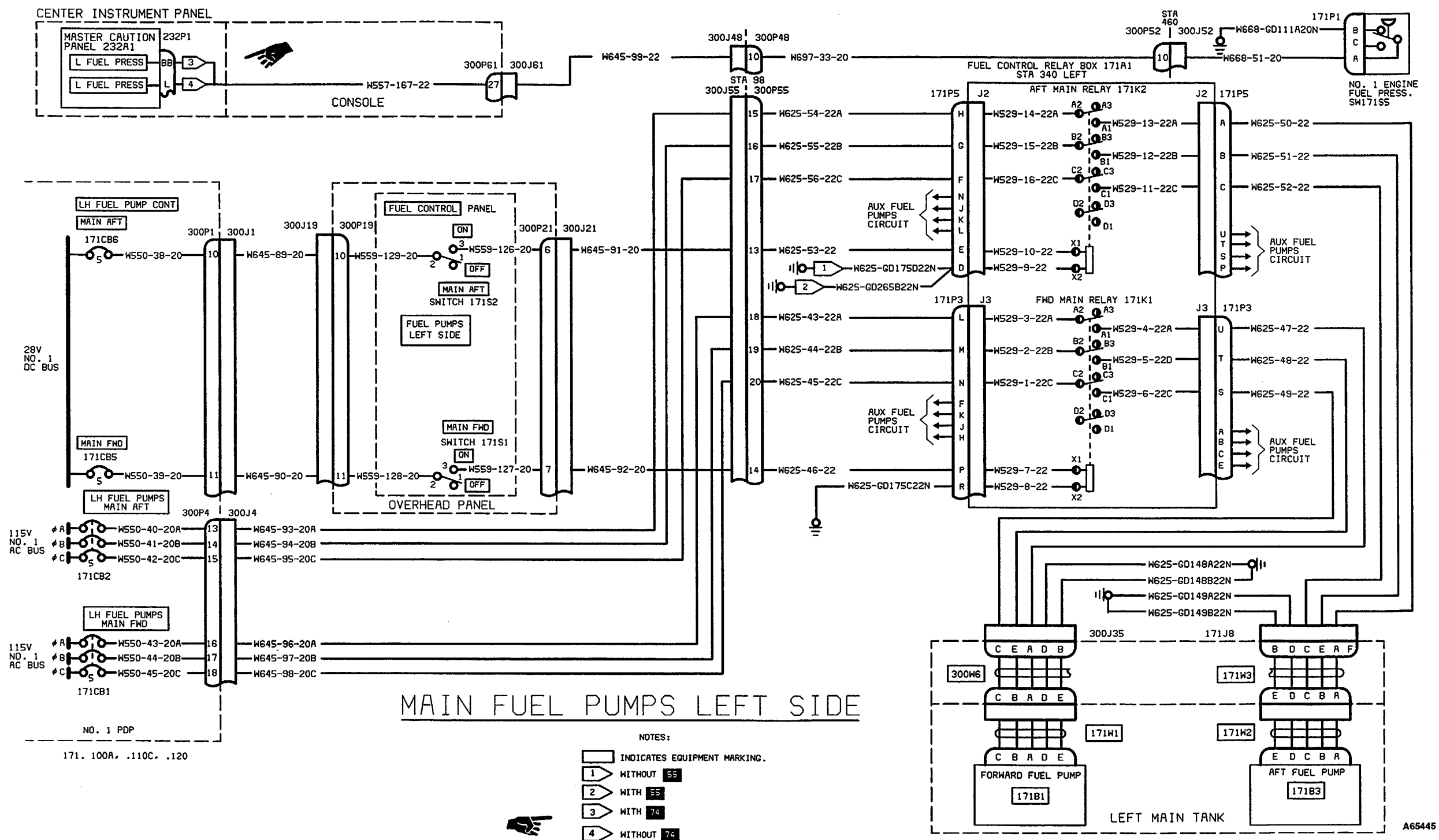

GO TO NEXT PAGE
Change 23 10-37

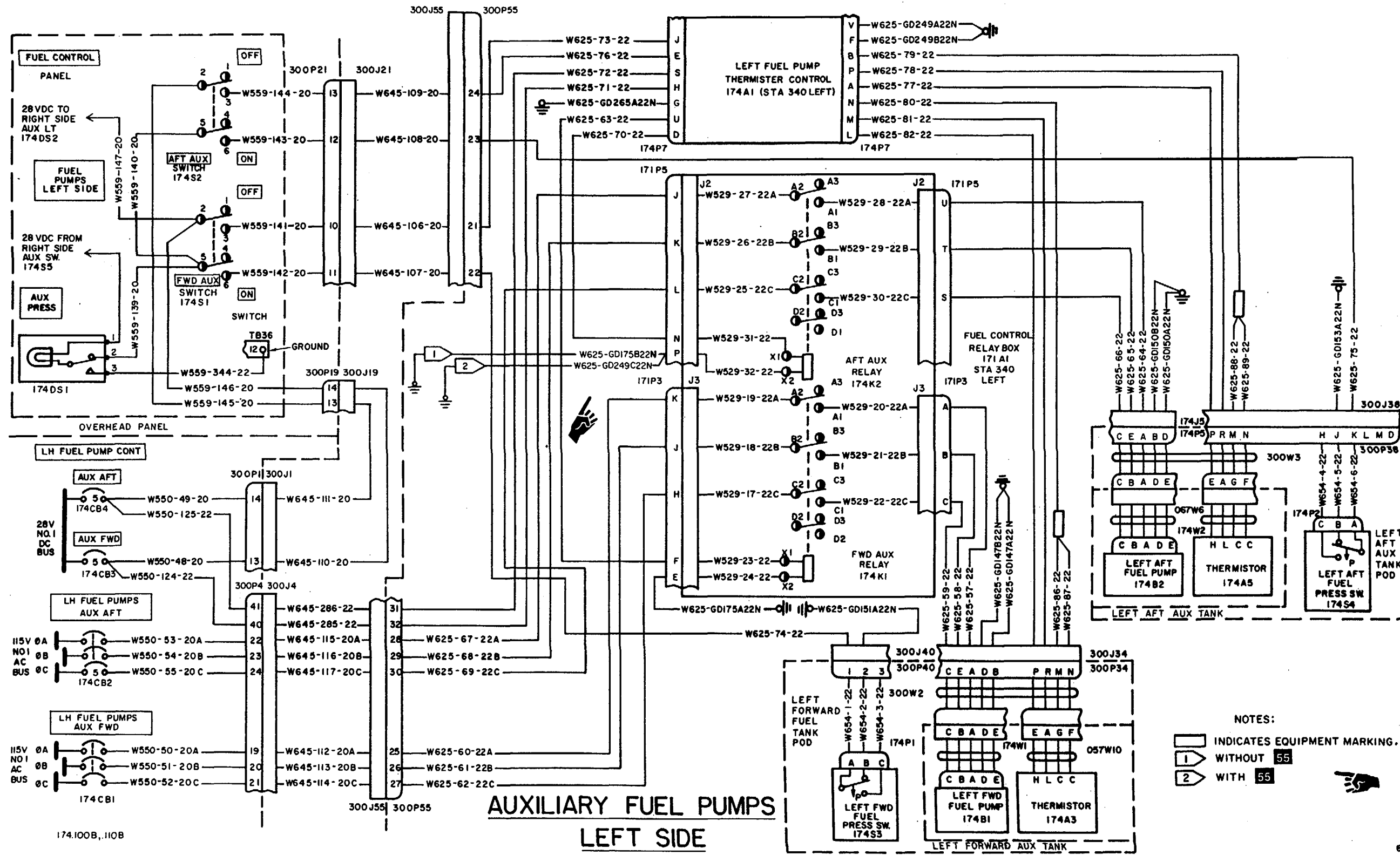

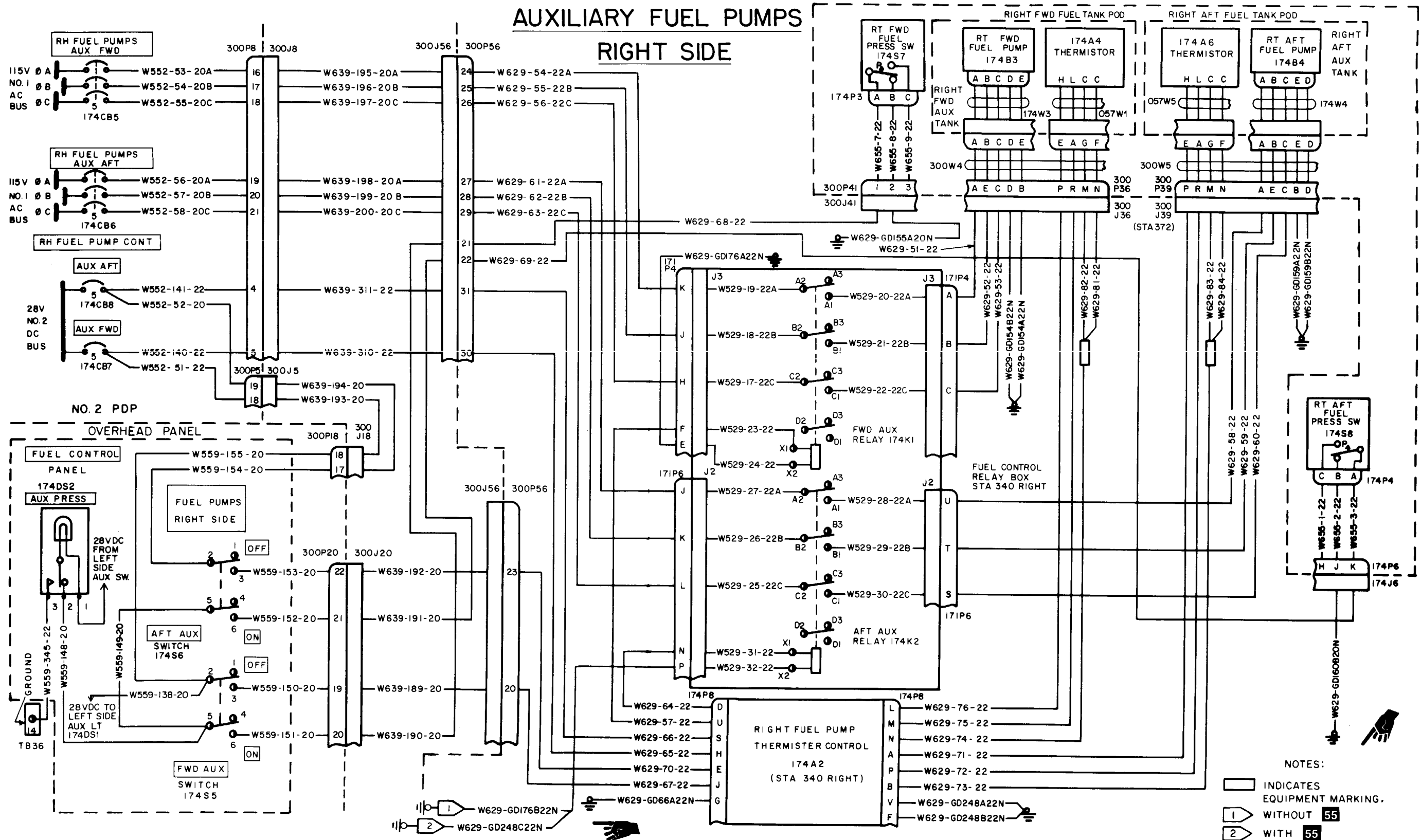

- NOTES:
- INDICATES EQUIPMENT MARKING.
 - ① WITHOUT 55
 - ② WITH 55

END OF TASK
Change 15 10-39

10-2.2 FUEL BOOST PUMP SYSTEM VISUAL CHECK

Applicable Configurations:

All

References:

TM 55-1520-240-23

Tools:

Electrical Repairer's Tool Kit,
NSN 5180-00-323-4915

Equipment Condition:

TM 55-1520-240-23:
Battery Disconnected
Electrical Power Off
Hydraulic Power Off
Left and Right Forward Landing Gear Access Panels Open
Left and Right Aft Intertank Pod Panels Open

Materials:

None

Personnel Required:

Aircraft Electrician

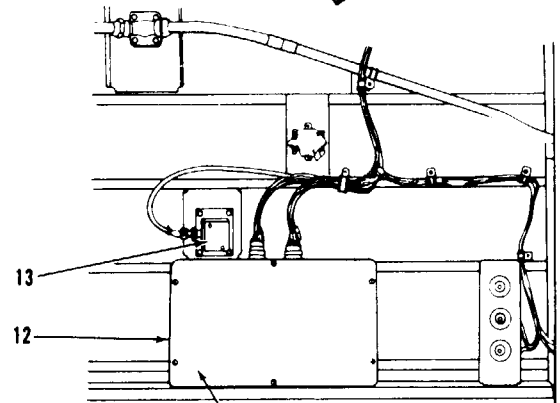
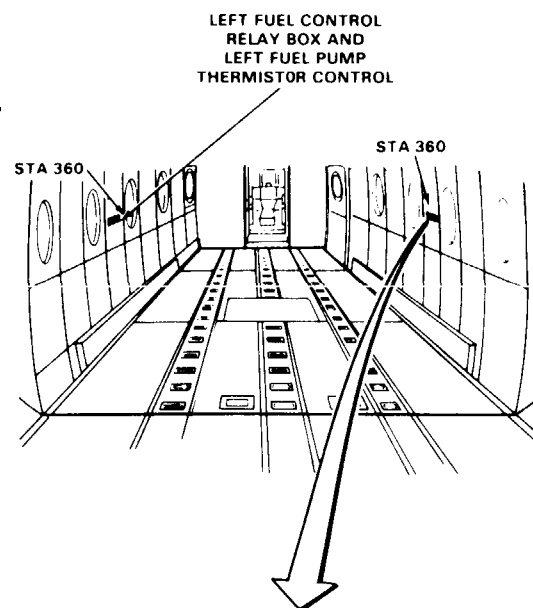
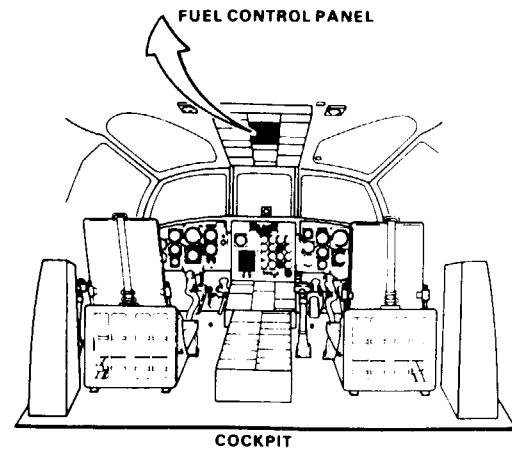
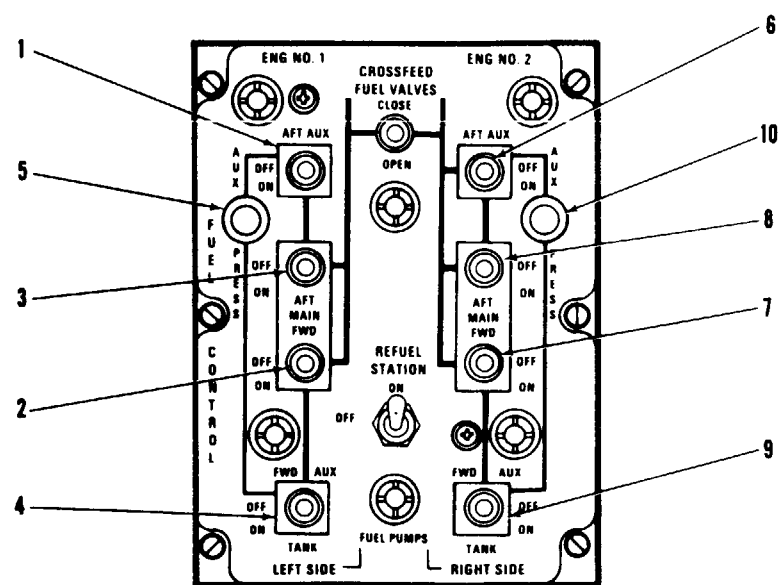

RIGHT FUEL CONTROL RELAY BOX AND RIGHT FUEL PUMP THERMISTOR CONTROL SHOWN. LEFT FUEL CONTROL RELAY BOX AND LEFT FUEL PUMP THERMISTOR CONTROL SIMILAR

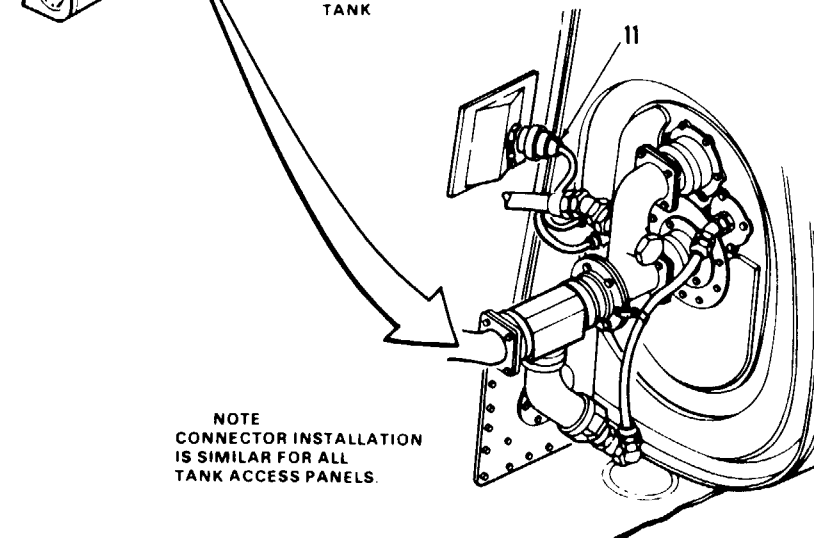
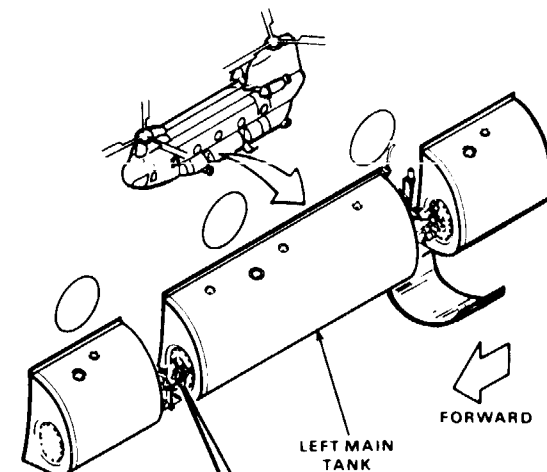
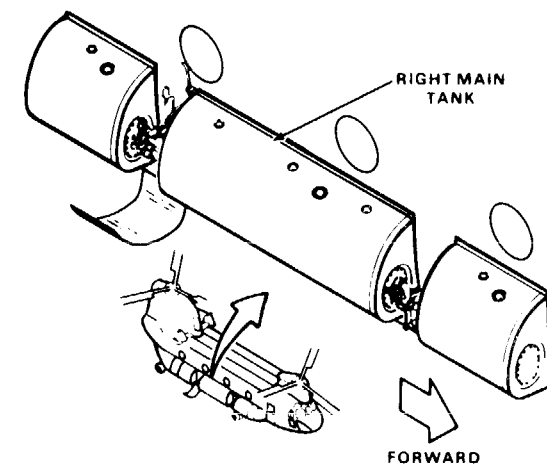

NOTE
CONNECTOR INSTALLATION IS SIMILAR FOR ALL TANK ACCESS PANELS

GO TO NEXT PAGE

**10-2.2 FUEL BOOST PUMP SYSTEM VISUAL CHECK
(Continued)**

TASK	RESULT	TASK	RESULT
1. On FUEL CONTROL panel, check LEFT SIDE AFT AUX, FWD and AFT MAIN, and FWD AUX boost pump switches (1, 2, 3, and 4).	If switches (1, 2, 3, and 4) are loose or damaged, tighten or replace them as required.	■ 13. Check right fuel control relay box (12).	If box (12) is loose or damaged, tighten or replace it as required. If either connector to box (12) is loose or damaged, tighten or replace it as required. If wiring to either connector is damaged, repair or replace it as required.
2. On FUEL CONTROL panel, check LEFT SIDE AUX PRESS light (5).	If light (5) is loose or damaged, tighten or replace it as required.	■ 14. Check right fuel pump thermister control (13).	If control (13) is loose or damaged, tighten or replace it as required. If connector to control is loose or damaged, tighten or replace it as required. If wiring to connector is damaged, repair or replace it as required.
3. On FUEL CONTROL panel, check RIGHT SIDE AFT AUX, FWD and AFT MAIN, and FWD AUX boost pump switches (6, 7, 8, and 9).	If switches (6, 7, 8, and 9) are loose or damaged, tighten or replace them as required.	■ 15. Repeat steps 13 and 14 for left fuel control relay box (12) and left fuel pump thermister control (13).	
4. On FUEL CONTROL panel, check RIGHT SIDE AUX PRESS light (10).	If light (10) is loose or damaged, tighten or replace it as required.		
5. On left FWD AUX tank access panel, check wiring and connector (11). damaged, repair or replace as required.	If connector (11) is loose or damaged, tighten or replace it as required. If wiring to connector is		
6. On left MAIN tank forward access panel, check wiring and connector (11). damaged, repair or replace as required.	If connector (11) is loose or damaged, tighten or replace it as required. If wiring to connector is		
7. On left MAIN tank aft access panel, check wiring and connector (11). damaged, repair or replace as required.	If connector (11) is loose or damaged, tighten or replace it as required. If wiring to connector is		
8. On left AFT AUX tank access panel, check wiring and connector (11). damaged, repair or replace as required.	If connector (11) is loose or damaged, tighten or replace it as required. If wiring to connector is		
9. On right FWD AUX tank access panel, check wiring and connector (11). damaged, repair or replace as required.	If connector (11) is loose or damaged, tighten or replace it as required. If wiring to connector is		
10. On right MAIN tank forward access panel, check wiring and connector (11). damaged, repair or replace as required.	If connector (11) is loose or damaged, tighten or replace it as required. If wiring to connector is		
11. On right MAIN tank aft access panel, check wiring and connector (11). damaged, repair or replace as required.	If connector (11) is loose or damaged, tighten or replace it as required. If wiring to connector is		
12. On right AFT AUX tank access panel, check wiring and connector (11). damaged, repair or replace as required.	If connector (11) is loose or damaged, tighten or replace it as required. If wiring to connector is		

FOLLOW-ON MAINTENANCE:
 TM 55-1520-240-23:
 Left and Right Forward Landing Gear Access Panels Closed
 Left and Right Aft Intertank Pod Panel Closed

END OF TASK

10-2.3 FUEL BOOST PUMP SYSTEM OPERATIONAL CHECK

INITIAL SETUP

Applicable Configurations:

All

Tools:

Electrical Repairer's Tool Kit,
NSN 5180-00-323-4915

Materials:

None

Personnel Required:

Aircraft Electrician
Rotary-Wing Aviator

References:

TM 55-1520-240-10
TM 55-1520-240-23

Equipment Condition:

TM 55-1520-240-23:
Battery Connected
Electrical Power On
Hydraulic Power Off
Visual Check of Fuel Boost Pump System Performed
(Task 10-2.2)

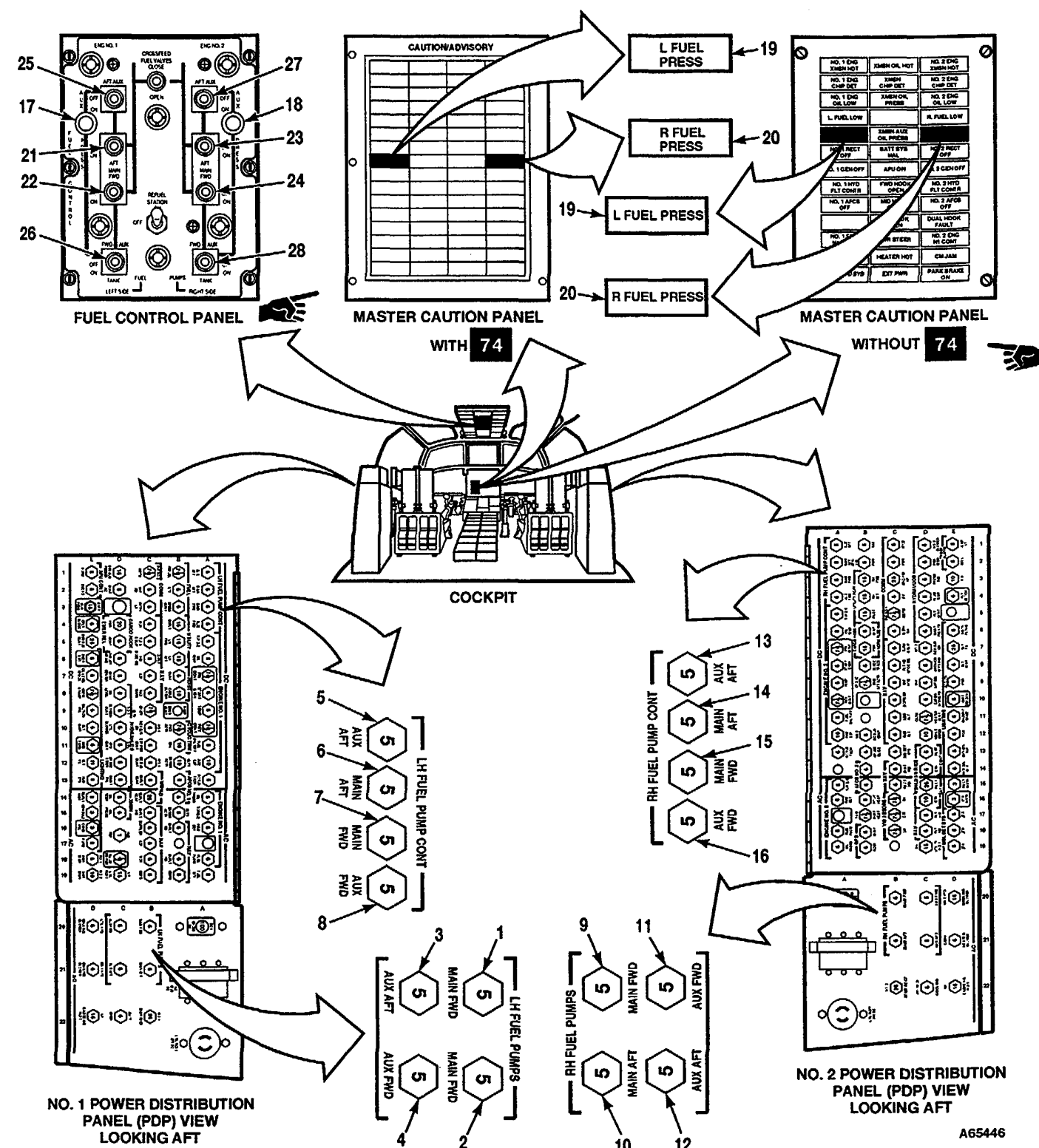

10-2.3 FUEL BOOST PUMP SYSTEM OPERATIONAL CHECK
(Continued)

10-2.3

TASK	RESULT
1. Check that LH FUEL PUMPS MAIN FWD, MAIN AFT, AUX FWD, and AUX AFT AC circuit breakers (1,2,3, and 4) are closed.	If circuit breaker (1) is open, close it, If it opens again, go to Task 10-2.4. If circuit breaker (2) is open, close it. If it opens again, go to Task 10-2.5. If circuit breaker (3) is open, close it. If it opens again, go to Task 10-2.6. If circuit breaker (4) is open, close it. If it opens again, go to Task 10-2.7.
2. Check that LH FUEL PUMP CONT AUX AFT, MAIN AFT, MAIN FWD, and AUX FWD DC circuit breakers (5,6, 7, and 8) are closed.	if circuit breaker (5) is open, close it, if it opens again, go to Task 10-2.8. If circuit breaker (6) is open, close it. If it opens again, go to Task 10-2.9 If circuit breaker (7) is open, close it. If it opens again, go to Task 10-2.10. If circuit breaker (8) is open, close it. If it opens again, go to Task 10-2.11.
3. Check that RH FUEL PUMPS MAIN FWD, MAIN AFT, AUX FWD, and AUX AFT AC circuit breakers (9, 10, 11, and 12) are closed.	If circuit breaker (9) is open, close it, If it opens again, go to Task 10-2.12. If circuit breaker (10) is open, close it, If it opens again, go to Task 10-2.13. If circuit breaker (11) is open, close it. If it opens again, go to Task 10-2.14. If circuit breaker (12) is open, close it. If it opens again, go to Task 10-2.15.
4. Check that RH FUEL PUMP CONT AUX AFT, MAIN AFT, MAIN FWD, and AUX FWD, DC circuit breakers (13, 14, 15, and 16) are closed.	If circuit breaker (13) is open, close it. If it opens again, go to Task 10-2.16. If circuit breaker (14) is open, close it. If it opens again, go to Task 10-2.17. If circuit breaker (15) is open, close it. If it opens again, go to Task 10-2.18. If circuit breaker (16) is open, close it. If it opens again, go to Task 10-2.19.
5. Check that all FUEL PUMP switches (21, 22, 23, 24, 25, 26, 27, 27 and 28) on FUEL CONTROL PANEL are set to OFF.	If switches are ON, set them to OFF.
6. Press and release LEFT SIDE AUX PRESSURE light (17).	AUX PRESSURE light (17) shall momentarily come on. If it does not, go to Task 10-2.20.
7. Press and release RIGHT SIDE AUX PRESSURE light (18).	AUX PRESSURE light (18) shall momentarily come on. If it does not, go to Task 10-2.20.

TASK	RESULT
WARNING	
An inoperative fuel pump in main tanks cannot be detected unless the following methods, steps 8 thru 17, are utilized. Flight operations with an undetected pump failure can result in engine flameout when operative pump fails. This could result in loss of helicopter lift.	
8. Check that L FUEL PRESS capsule (19) is lit.	If capsule (19) is not lit, go to Task 10-2.21.
9. Check that R FUEL PRESS capsule (20) is lit.	If capsule (20) is not lit, go to Task 10-2.21.
10. Have pilot start engines and stabilize rotors at ground idle. Set eight FUEL PUMP switches (21 through 28) to OFF.	
11. Set LEFT SIDE MAIN AFT FUEL PUMP switch (21) to ON.	Capsule (19) shall go out. If not, go to Task 10-2.22.
12. Set LEFT SIDE MAIN AFT FUEL PUMP switch (21) to OFF.	Capsule (19) shall come on. If not, go to Task 10-2.21.
13. Set LEFT SIDE MAIN FWD FUEL PUMP switch (22) to ON.	Capsule (19) shall go out. If not, go to Task 10-2.23.
14. Set LEFT SIDE MAIN FWD FUEL PUMP switch (22) to OFF.	Capsule (19) shall come on. If not, go to Task 10-2.21.
15. Set RIGHT SIDE MAIN FWD FUEL PUMP switch (24) to ON.	Capsule (20) shall go out. If not, go to Task 10-2.24.
16. Set RIGHT SIDE MAIN FWD FUEL PUMP switch (24) to OFF.	Capsule (20) shall come on. If not, go to Task 10-2.21.
17. Set RIGHT SIDE MAIN AFT FUEL PUMP switch (23) to ON.	Capsule (20) shall go out. If not, go to Task 10-2.25.
18. Set RIGHT SIDE MAIN AFT FUEL PUMP switch (23) to OFF.	Capsule (20) shall come on. If not, go to Task 10-2.21.

GO TO NEXT PAGE

TASK	RESULT
19. Set LEFT SIDE AFT AUX FUEL PUMP switch (25) to ON.	AUX PRESS light (17) shall stay out. If it is on, go to task 10-2.26.
20. Set LEFT SIDE AFT AUX FUEL PUMP switch (25) to OFF.	
21. Set LEFT SIDE FWD AUX FUEL PUMP switch (26) to ON.	AUX PRESS light (17) shall stay out. If it is on, go to task 10-2.27.
22. Set LEFT SIDE FWD AUX FUEL PUMP switch (26) to OFF.	
23. Set RIGHT SIDE AFT AUX FUEL PUMP switch (27) to ON.	AUX PRESS light (18) shall stay out. If it is on, go to task 10-2.28.
24. Set RIGHT SIDE AFT AUX FUEL PUMP switch (27) to OFF.	
25. Set RIGHT SIDE FWD AUX FUEL PUMP switch (28) to ON.	AUX PRESS light (18) shall stay out. If it is on, go to task 10-2.29.
26. Set RIGHT SIDE FWD AUX FUEL PUMP switch (28) to OFF.	
27. Have pilot shut down engines.	

CHECK AUX TANK FUEL PUMP SHUTOFF (NO FUEL)

- | | |
|---|--|
| <p>28. Check that fuel level in main tank is low enough to accept transfer of fuel from associated auxiliary tanks.</p> <p>29. (Deleted.)</p> <p>30. (Deleted.)</p> | <p>If too much fuel is in main tank, remove quantity required. Refer to TM 55-1520-240-23.</p> |
|---|--|

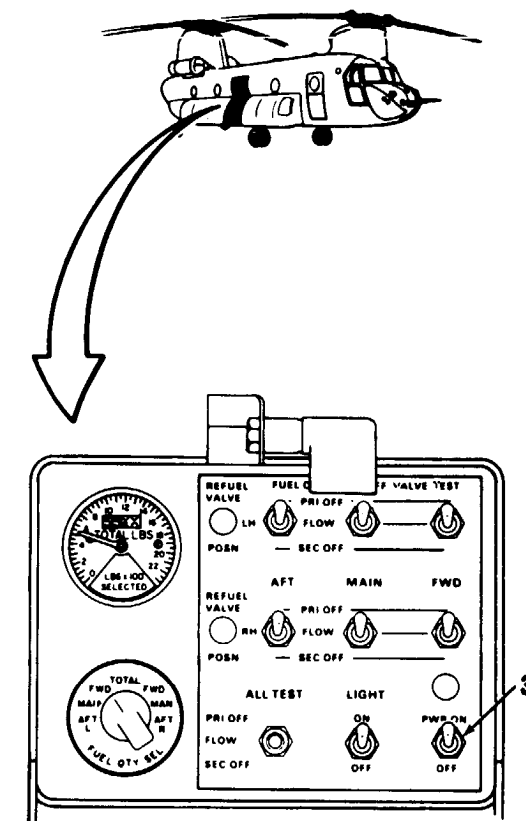
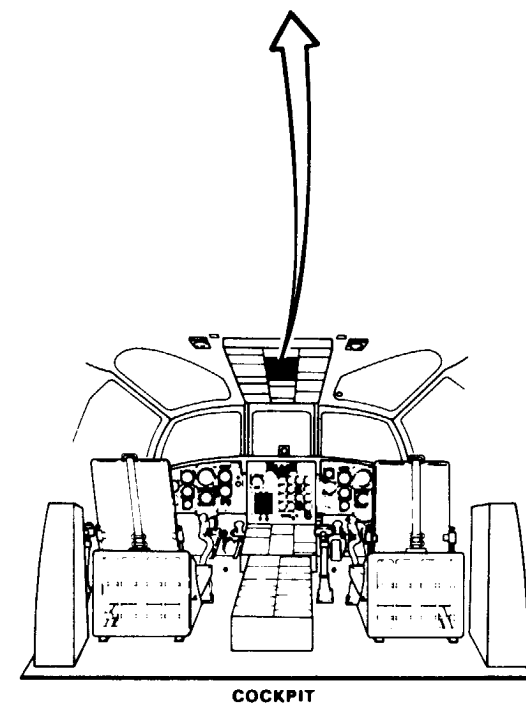
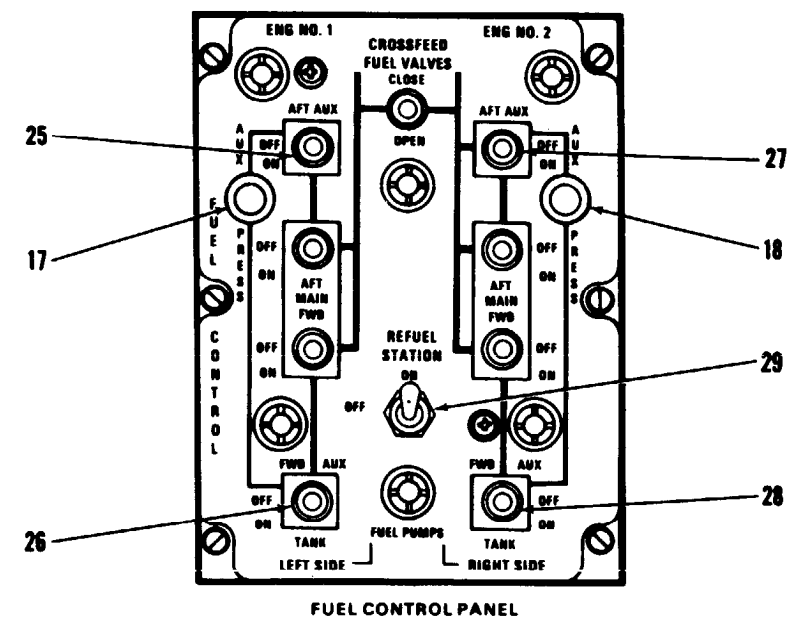

TASK	RESULT
<p>31. Set RIGHT SIDE FWD AUX FUEL PUMP switch (28) to ON. Have helper standby right side fwd aux tank and listen for operation of boost pump.</p>	<p>AUX PRESS light (18) will go out. If not, go to task 10-2.29. Fuel will transfer from RIGHT SIDE FWD AUX tank to RIGHT SIDE MAIN TANK. AUX PRESS light (18) will come on when RIGHT SIDE FWD AUX tank is depleted. The fuel pump will shut off automatically. If fuel pump continues running after AUX PRESS light comes on and tank is empty, replace right side thermistor control box.</p>
<p>32. Set RIGHT SIDE AFT AUX FUEL PUMP switch (27) to ON. Have helper standby right side aft aux tank and listen for operation of boost pump.</p>	<p>AUX PRESS light (18) will go out. If not, go to task 10-2.28. Fuel will transfer from RIGHT SIDE AFT AUX tank to RIGHT SIDE MAIN TANK. AUX PRESS light (18) will come on when RIGHT SIDE AFT AUX tank is depleted. The fuel pump will shutoff automatically. If fuel pump continues running after AUX PRESS light comes on and tank is empty, replace right side thermistor control box.</p>

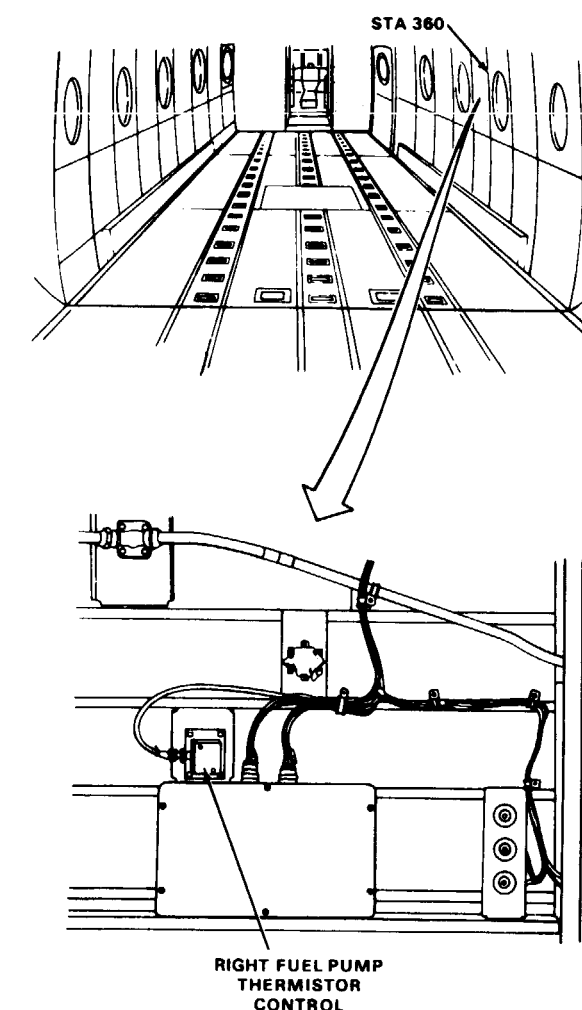
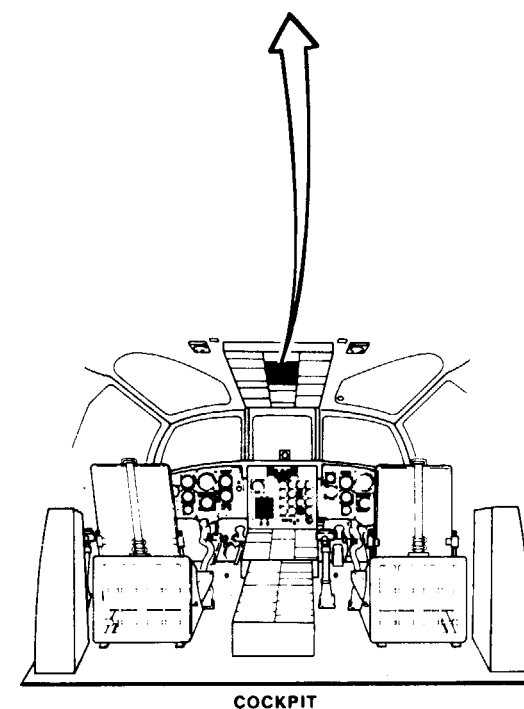
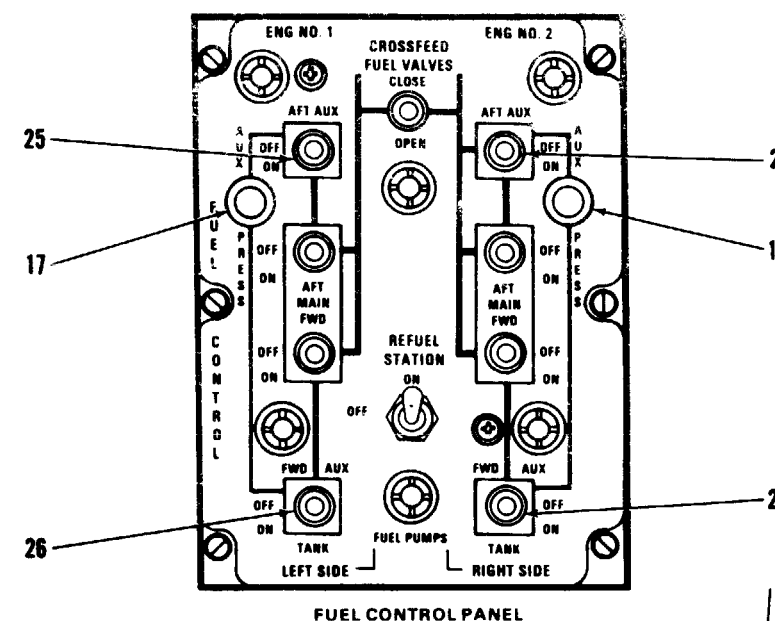

TASK	RESULT
33. Set LEFT SIDE FWD AUX FUEL PUMP switch (26) to ON. Have helper standby left side fwd aux tank and listen for operation of boost pump.	AUX PRESS light (17) will go out. If not, go to task 10-2.27. Fuel will transfer from LEFT SIDE FWD AUX TANK to LEFT SIDE MAIN TANK. AUX PRESS light (17) will come on when LEFT SIDE FWD AUX tank is depleted. The fuel pump will shut off automatically. If fuel pump continues running after AUX PRESS light comes on and tank is empty, replace left side thermistor control box.
34. Set LEFT SIDE AFT AUX FUEL PUMP switch (25) to ON. Have helper standby left side aft aux tank and listen for operation of boost pump.	Fuel will transfer from LEFT SIDE AFT AUX tank to LEFT SIDE MAIN tank. AUX PRESS light (17) will come on when LEFT SIDE AFT AUX tank is depleted. The fuel pump will shut off automatically. If fuel pump continues running after AUX PRESS light comes on and tank is empty, replace left side thermistor control box.

FOLLOW-ON MAINTENANCE:
 TM 55-1520-240-23:
 Battery Disconnected
 Electrical Power Off

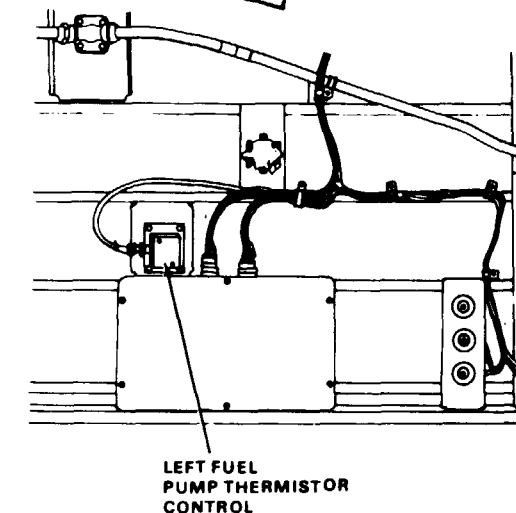
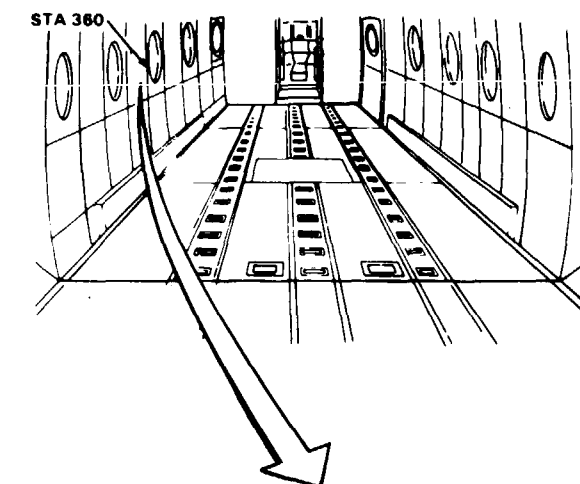
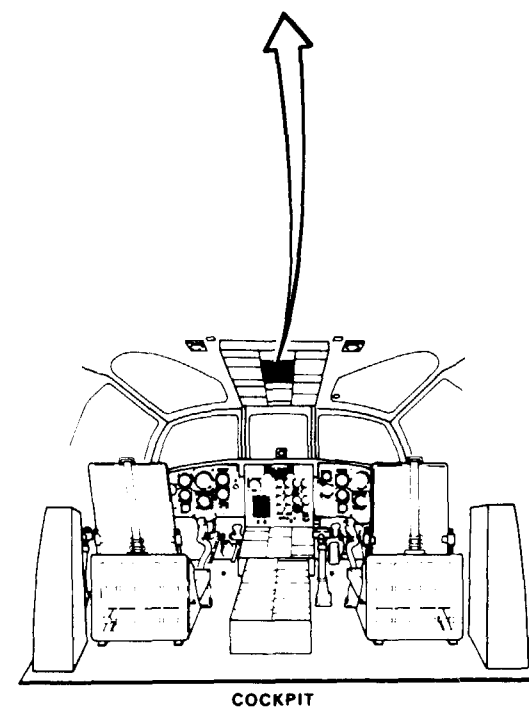
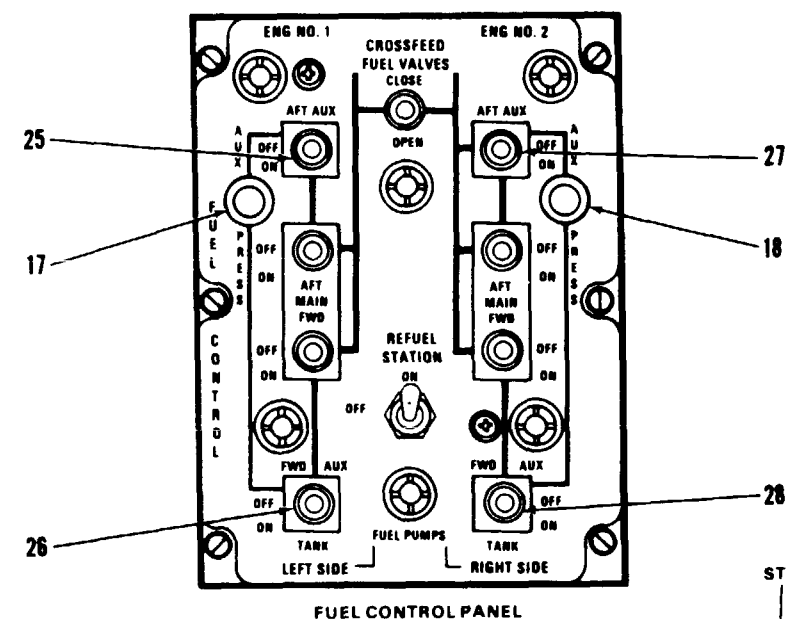

FAULT ISOLATION PROCEDURE

INITIAL SETUP

Applicable Configurations:

All

Tools:

Electrical Repairer's Tool Kit,
NSN 5180-00-323-4915
Multimeter

Materials:

None

Personnel Required:

Aircraft Electrician (2)

References:

TM 55-1520-240-23

Equipment Condition:

TM 55-1520-240-23:
Battery Connected
Electrical Power On
Hydraulic Power Off
Side Acoustical Blanket Removed Between Sta
320 and 360
Left Fwd Landing Gear Access Panel Open

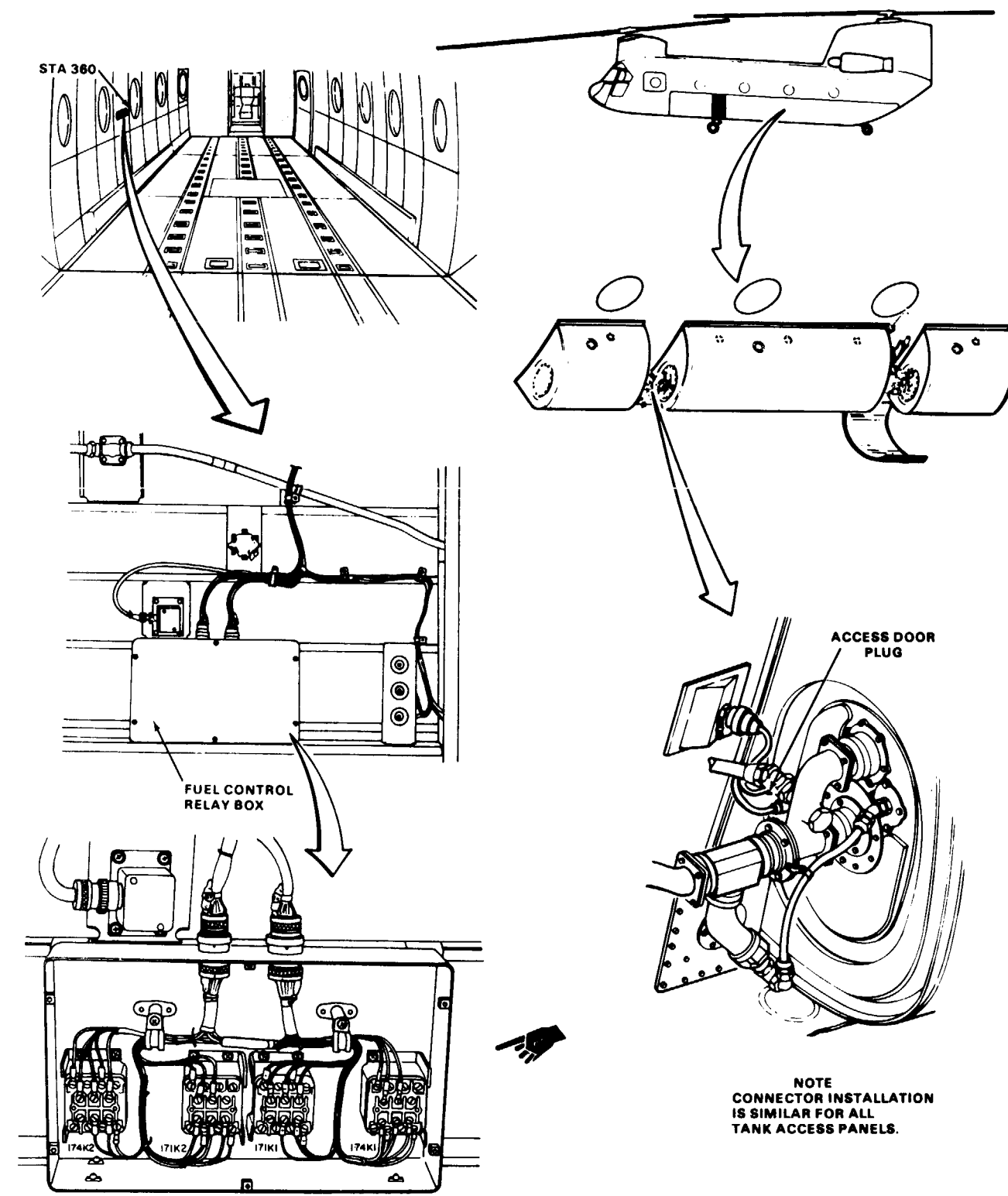
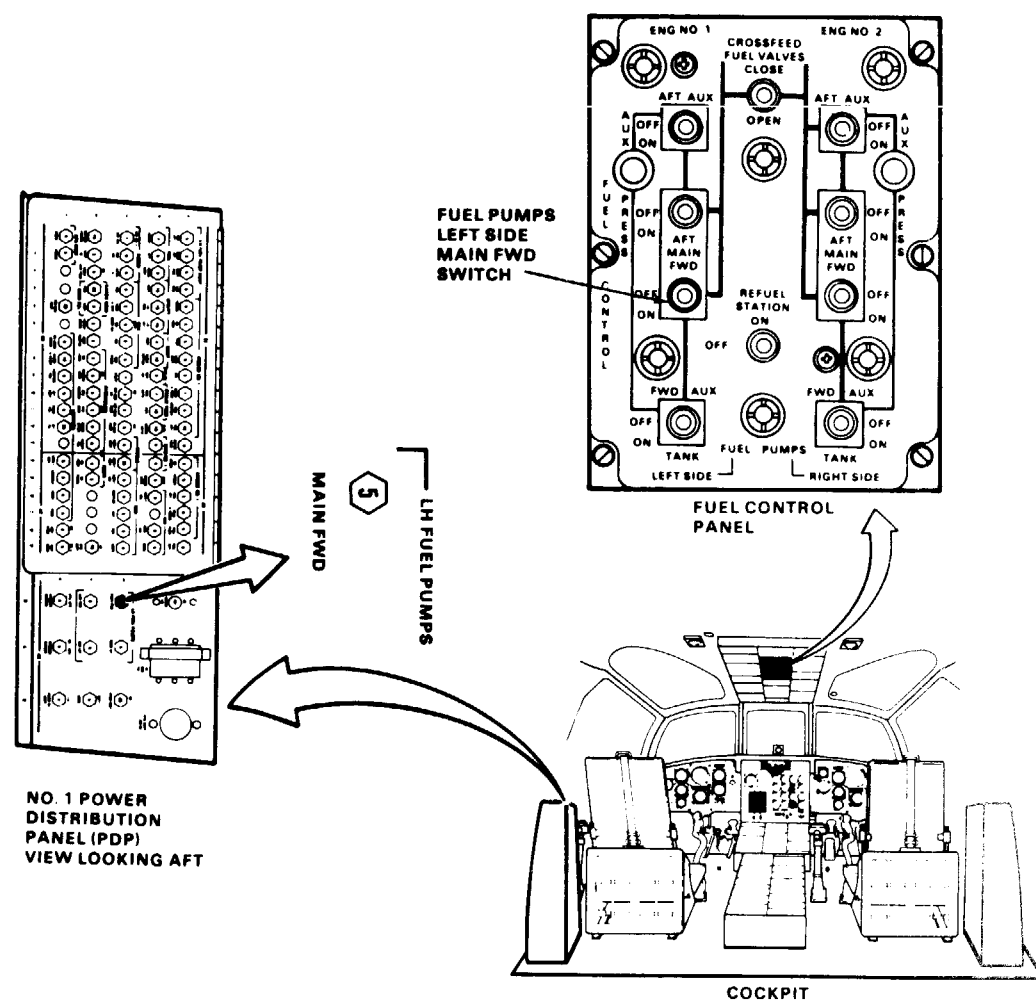

NOTE
CONNECTOR INSTALLATION
IS SIMILAR FOR ALL
TANK ACCESS PANELS.

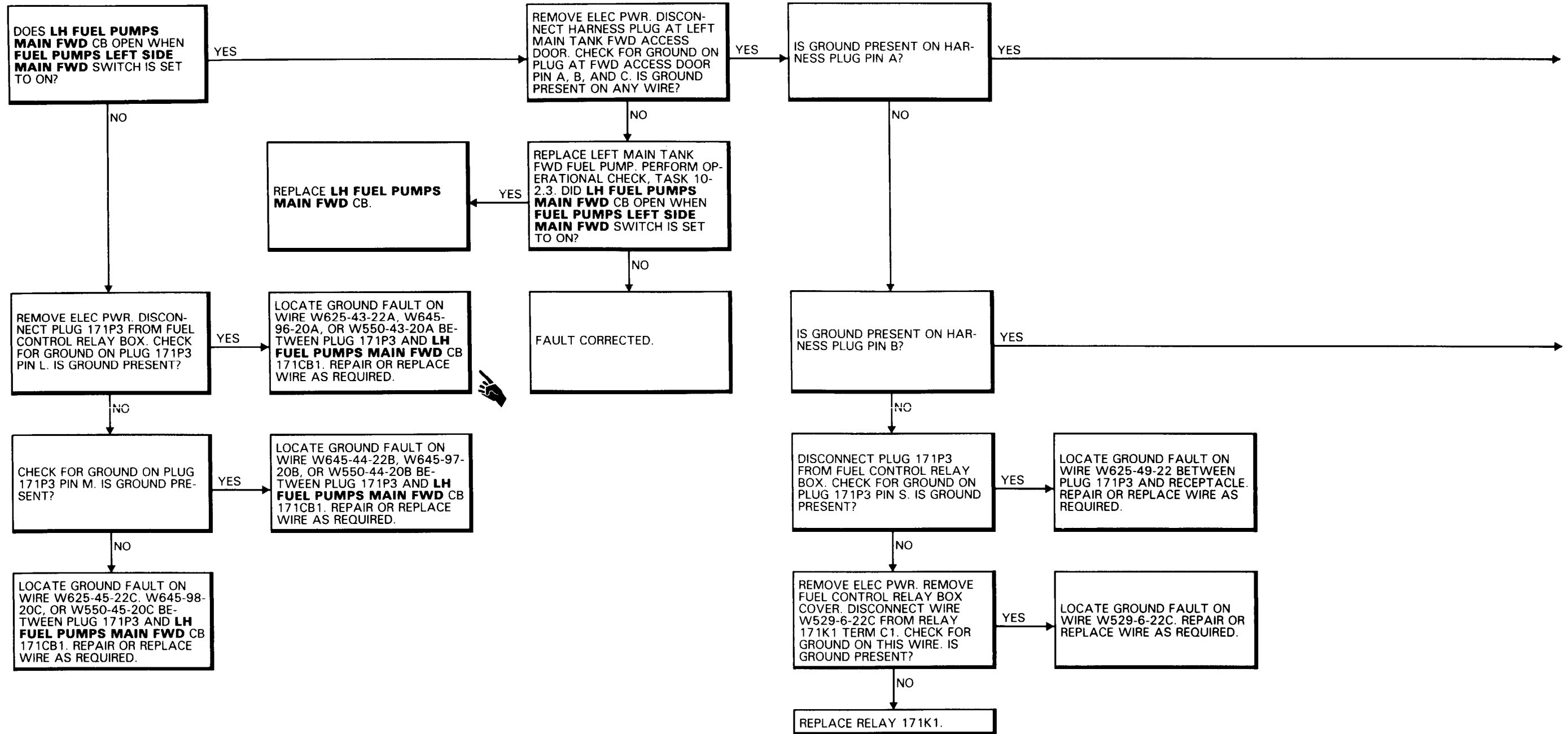

10-2.4 LH FUEL PUMPS MAIN FWD CIRCUIT BREAKER WILL NOT STAY CLOSED (Continued)

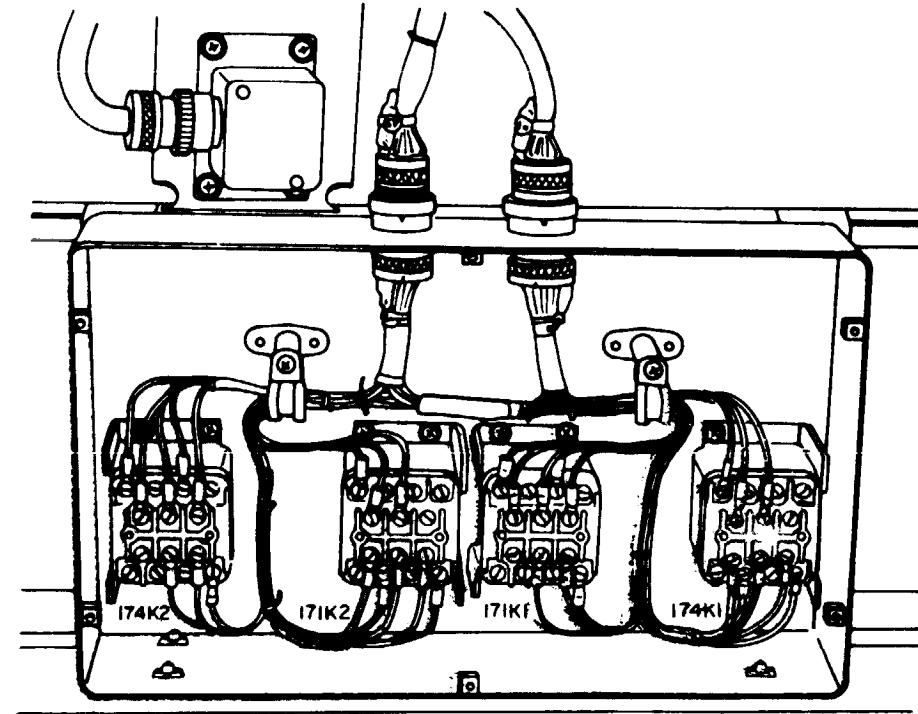
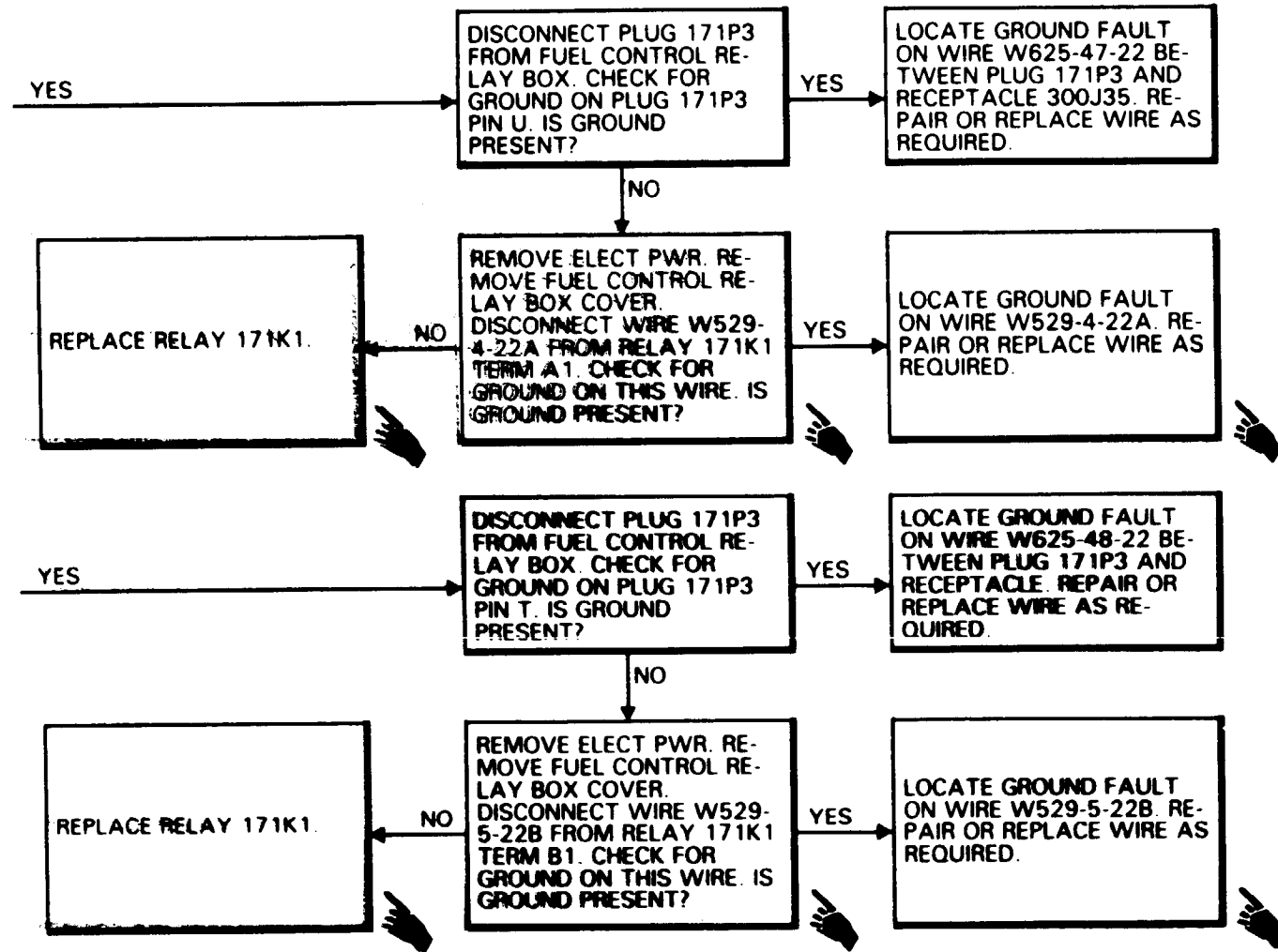

FAULT /SOLUTION PROCEDURE

INITIAL SETUP

Applicable Configurations:

All

Tools:

- Electrical Repairer's Tool Kit,
NSN 5180-00-323-4915
- Multimeter

Materials:

None

Personnel Required:

- Aircraft Electrician (2)

References

TM 55-1520-240-23

Equipment Condition:

TM 55-1520-240-23:

- Battery Connected
- Electrical Power On
- Hydraulic Power Off
- Side Acoustical Blanket Removed Between Sta 320 and 360
- Left Aft Intertank Access Panel Open

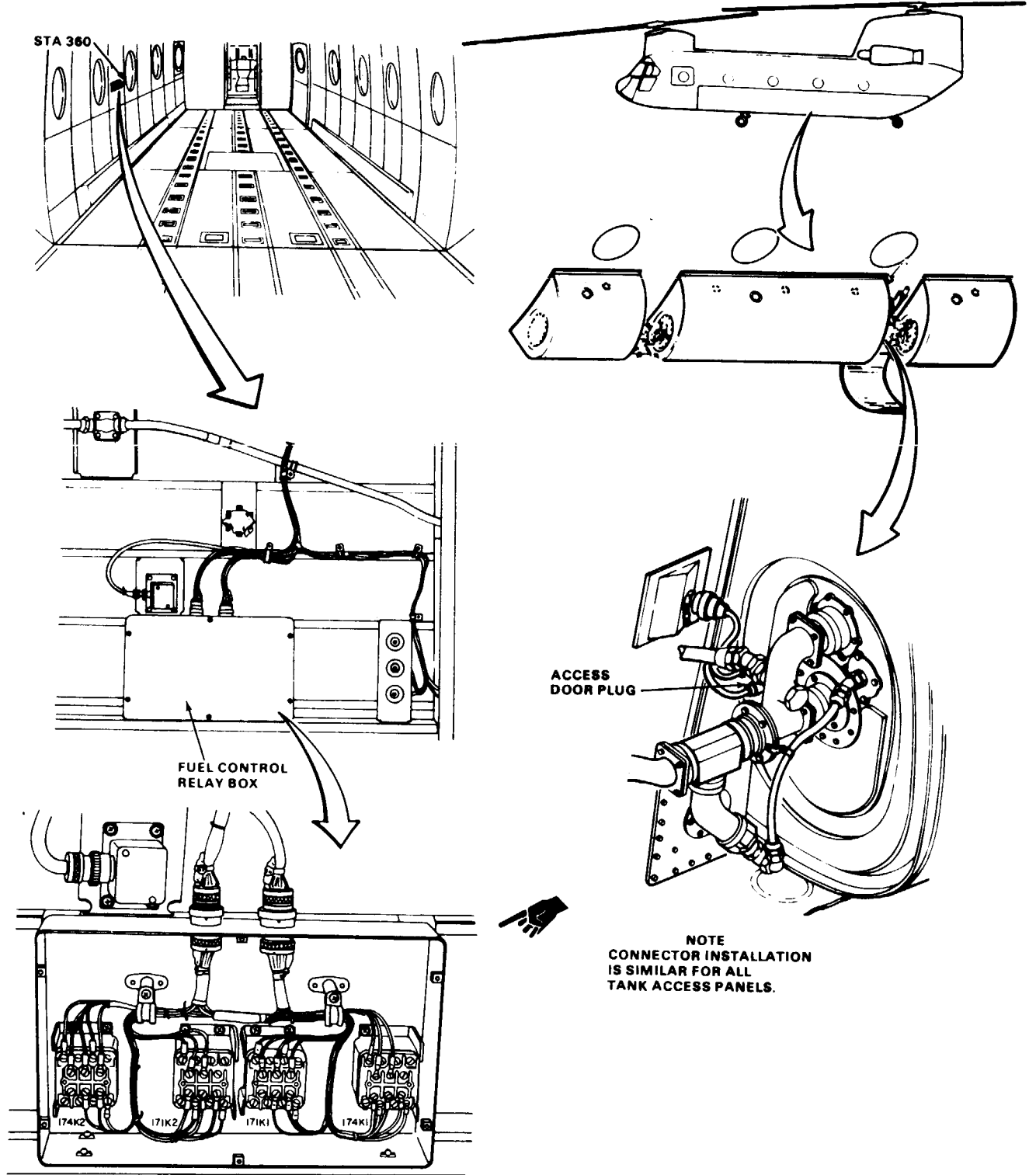
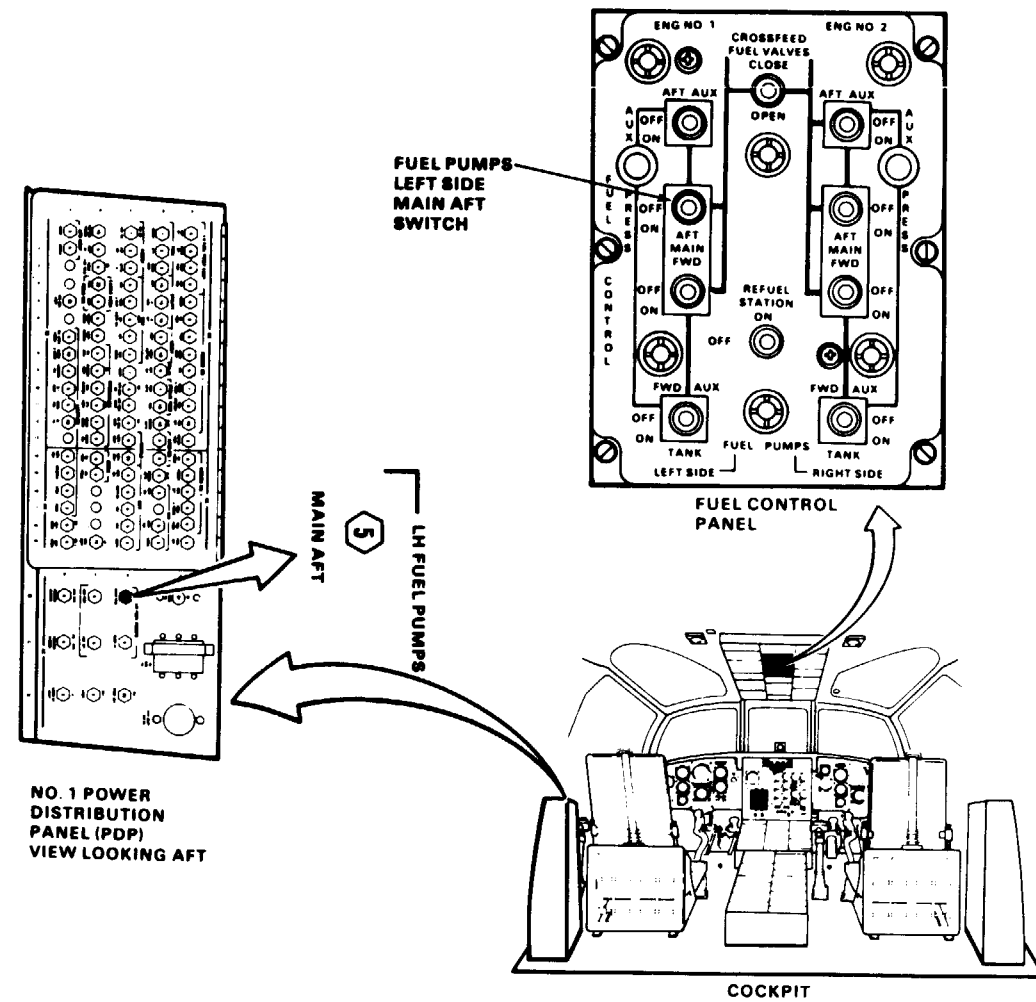

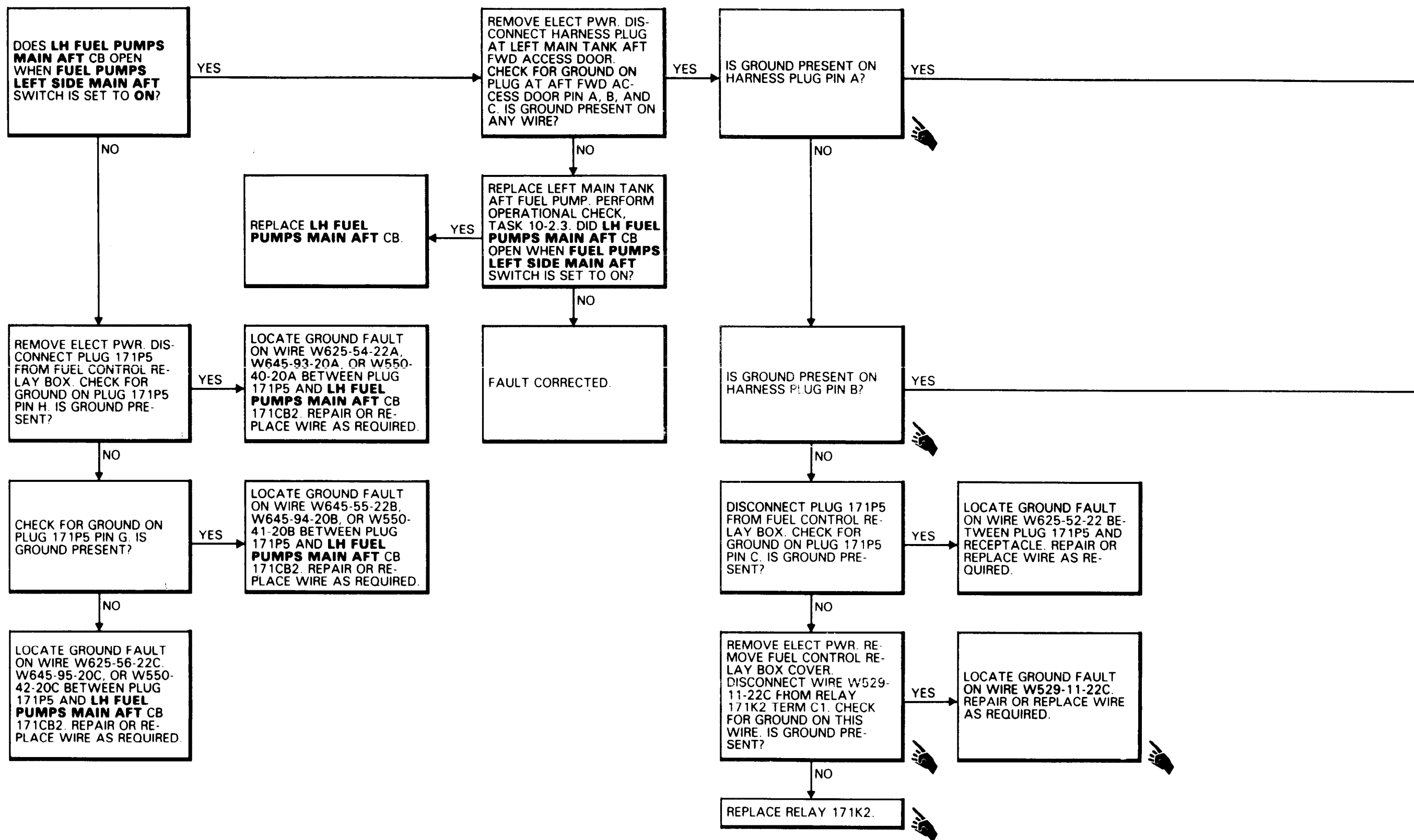

10-2.5 LH FUEL PUMPS MAIN AFT CIRCUIT BREAKER WILL NOT STAY CLOSED (Continued)

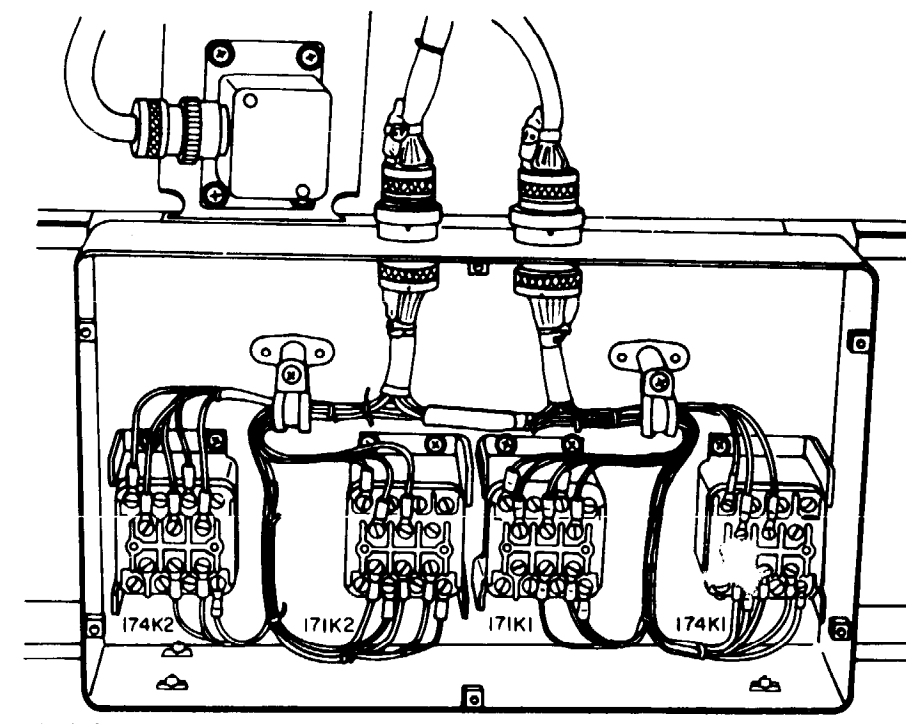
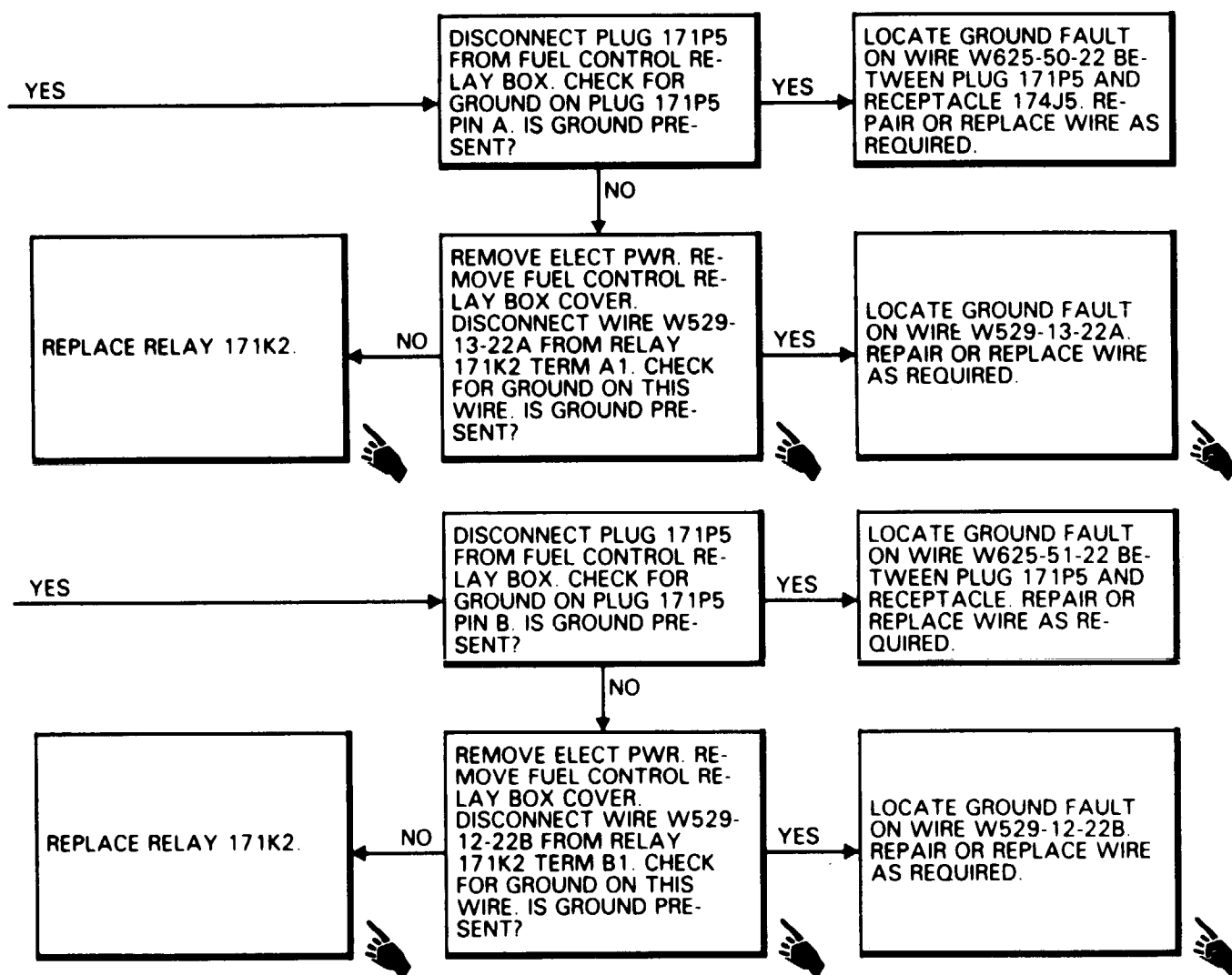

10.2.6 LH FUEL PUMPS AUX FWD CIRCUIT BREAKER WILL NOT STAY CLOSED

FAULT ISOLATION PROCEDURE

INITIAL SETUP

Applicable Configurations:

All

Tools:

- Electrical Repairer's Tool Kit,
NSN 5180-00-323-4915
- Multimeter

Materials:

None

Personnel Required

- Aircraft Electrician (2)

References:

TM 55-1520-240-23

Equipment Condition:

TM 55-1520-240-23:

- Battery Connected
- Electrical Power On
- Hydraulic Power Off
- Side Acoustical Blanket Removed Between Sta 320 and 360
- Left Forward Landing Gear Access Panel Open

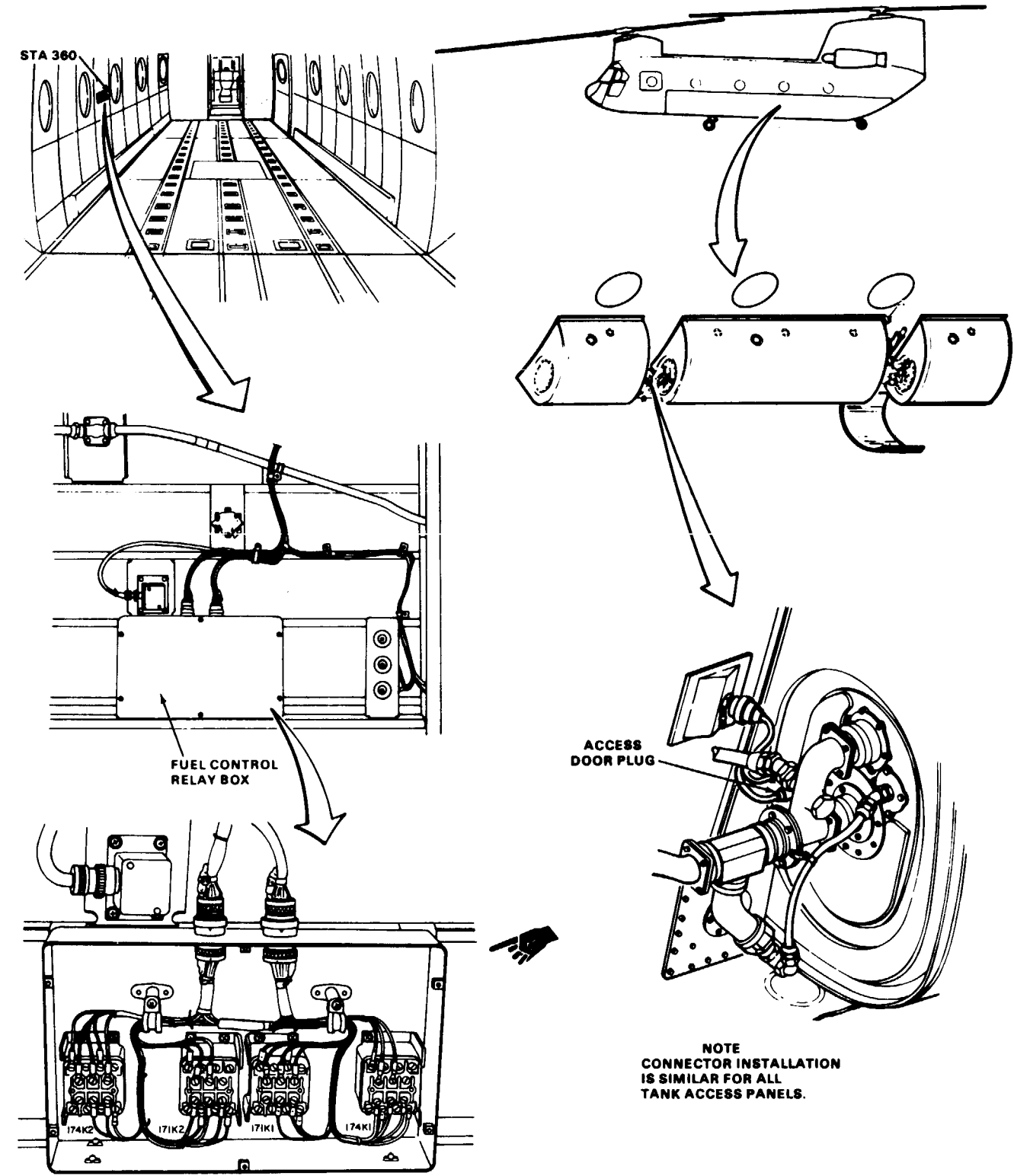
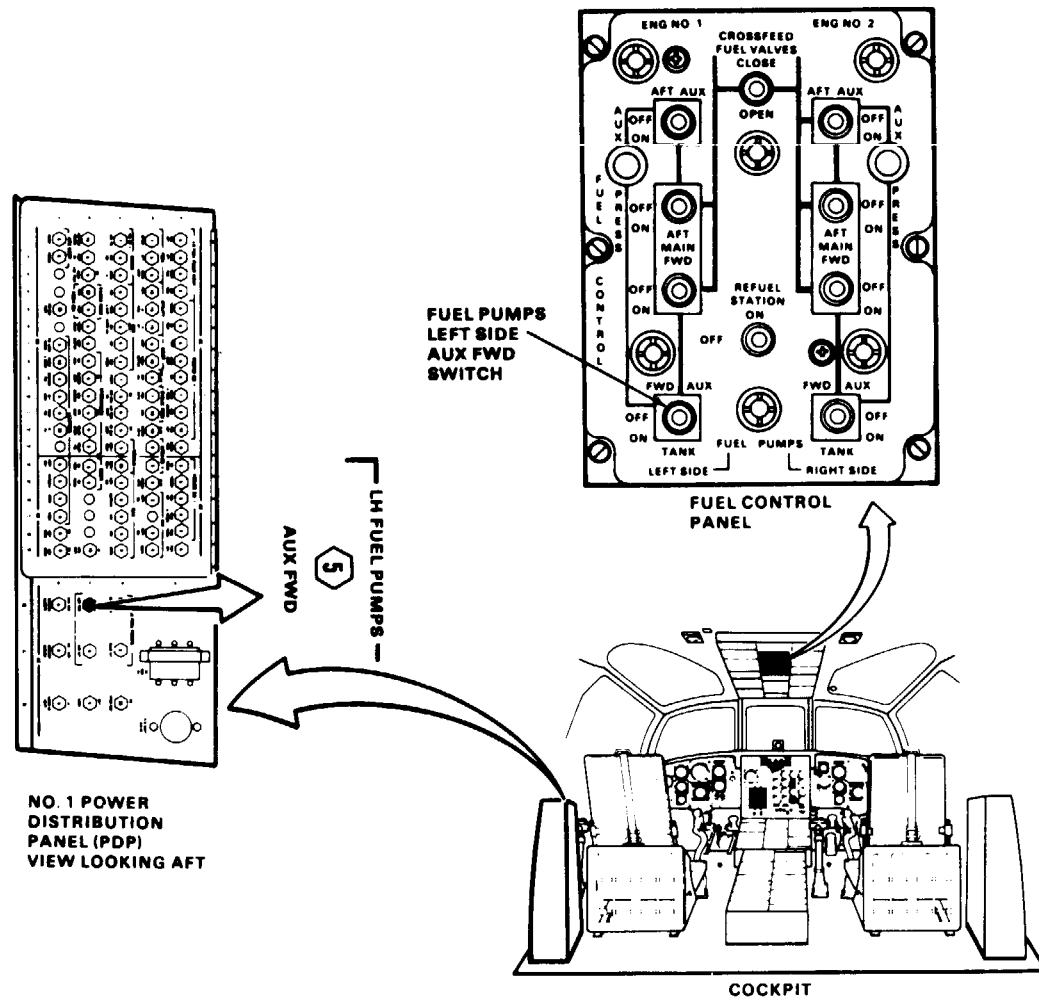

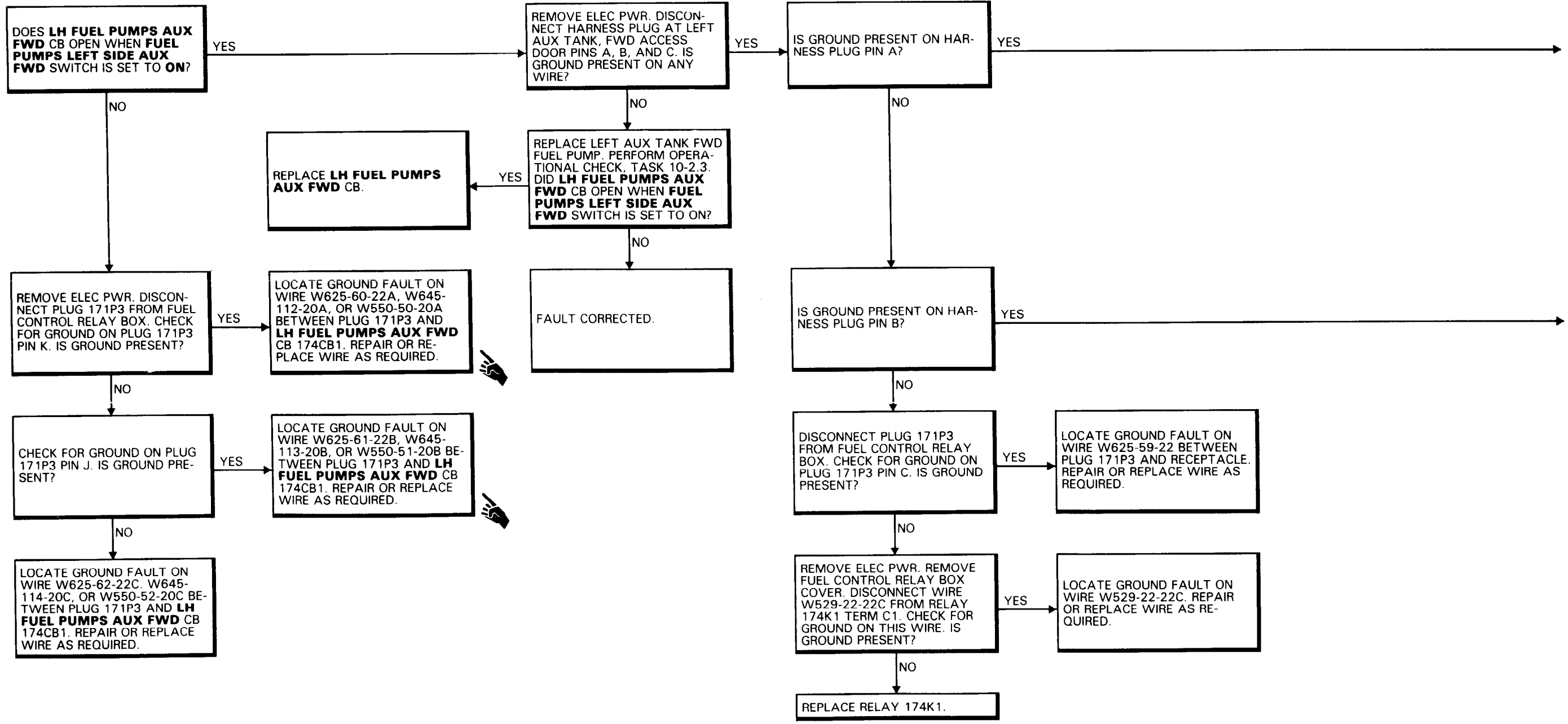

10-2.6 LH FUEL PUMPS AUX FWD CIRCUIT BREAKER WILL NOT STAY CLOSED (Continued)

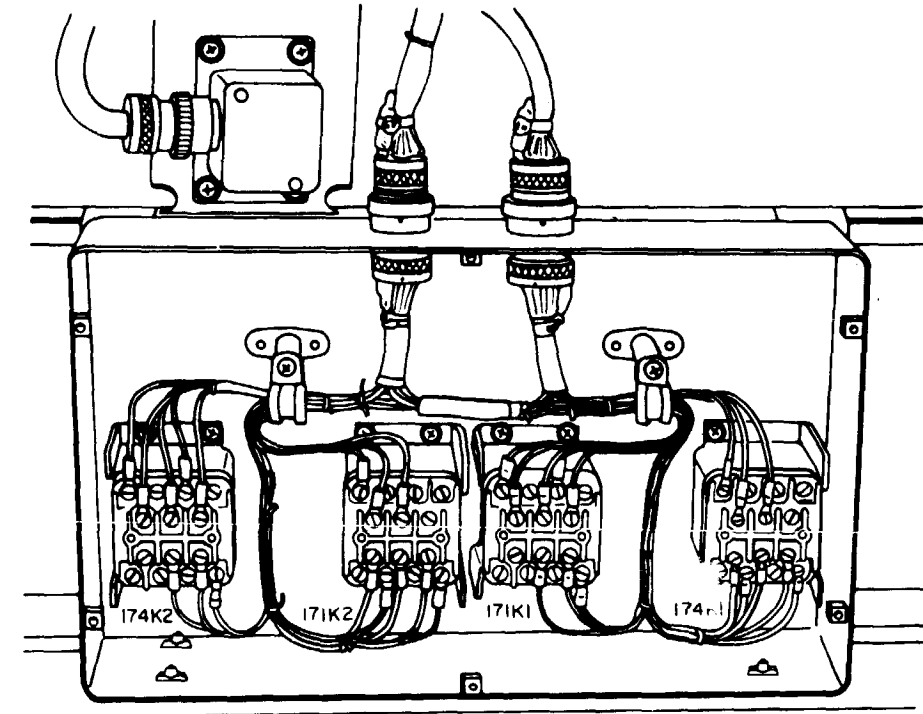
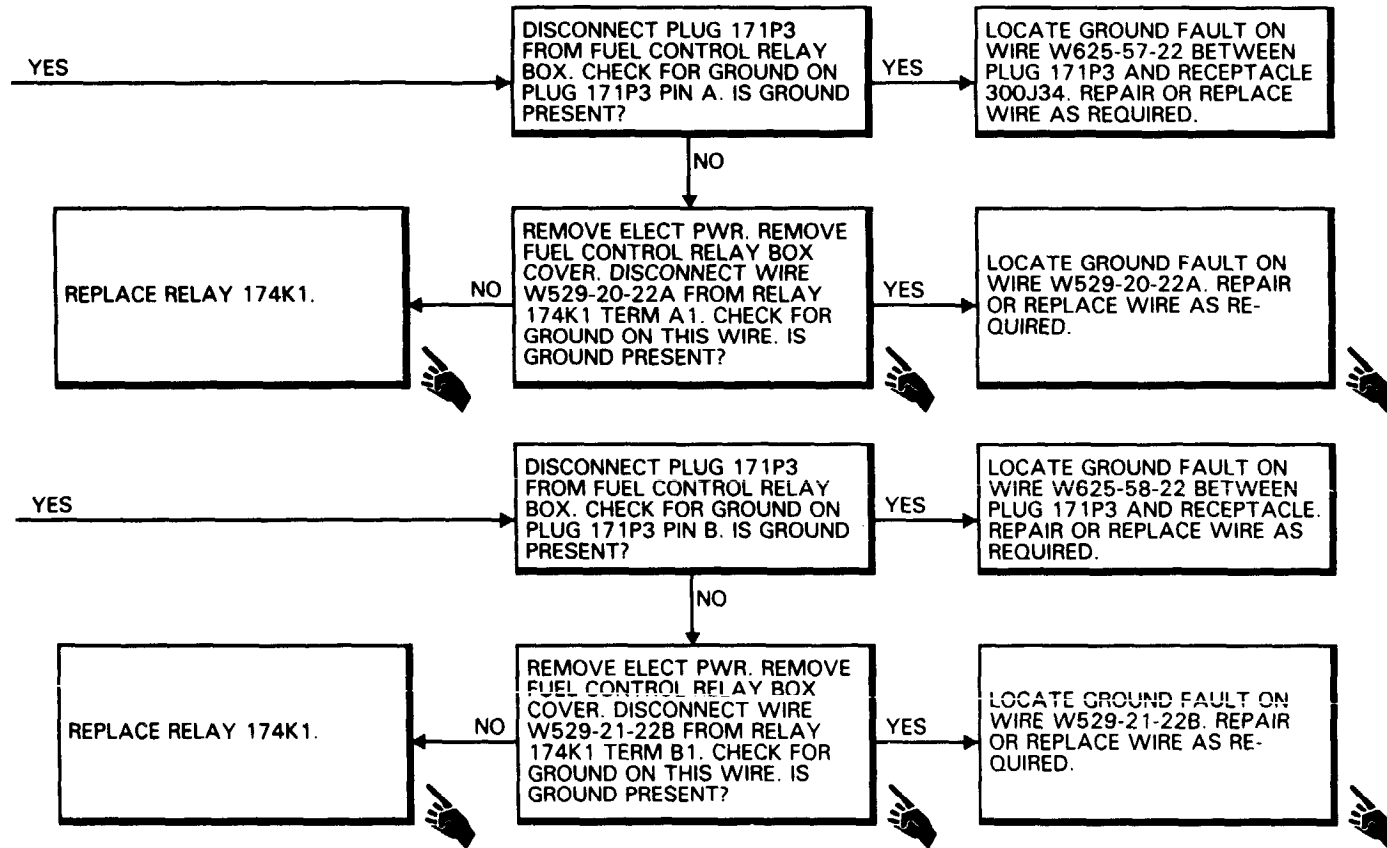

FAULT ISOLATION PROCEDURE

INITIAL SETUP

Applicable Configurations:

All

Tools:

- Electrical Repairer's Tool Kit,
NSN 5180-00-323-4915
- Multimeter

Materials:

None

Personnel Required:

- Aircraft Electrician (2)

References:

TM 55-1520-240-23

Equipment Condition:

TM 55-1520-240-23:

- Battery Connected
- Electrical Power On
- Hydraulic Power Off

Side Acoustical Blanket Removed Between Sta 320 and 360

Left Aft Intertank Access Panel Open

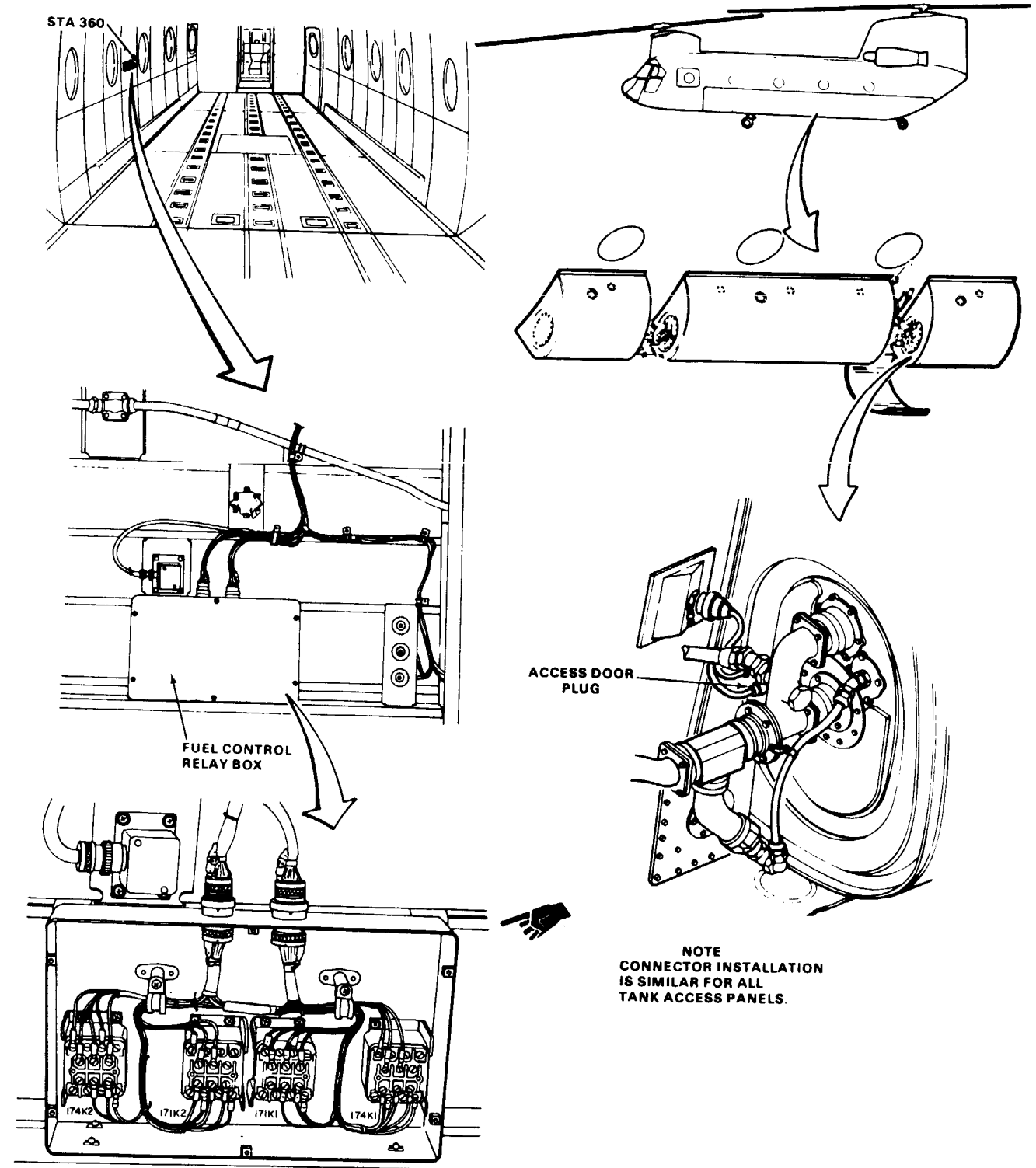
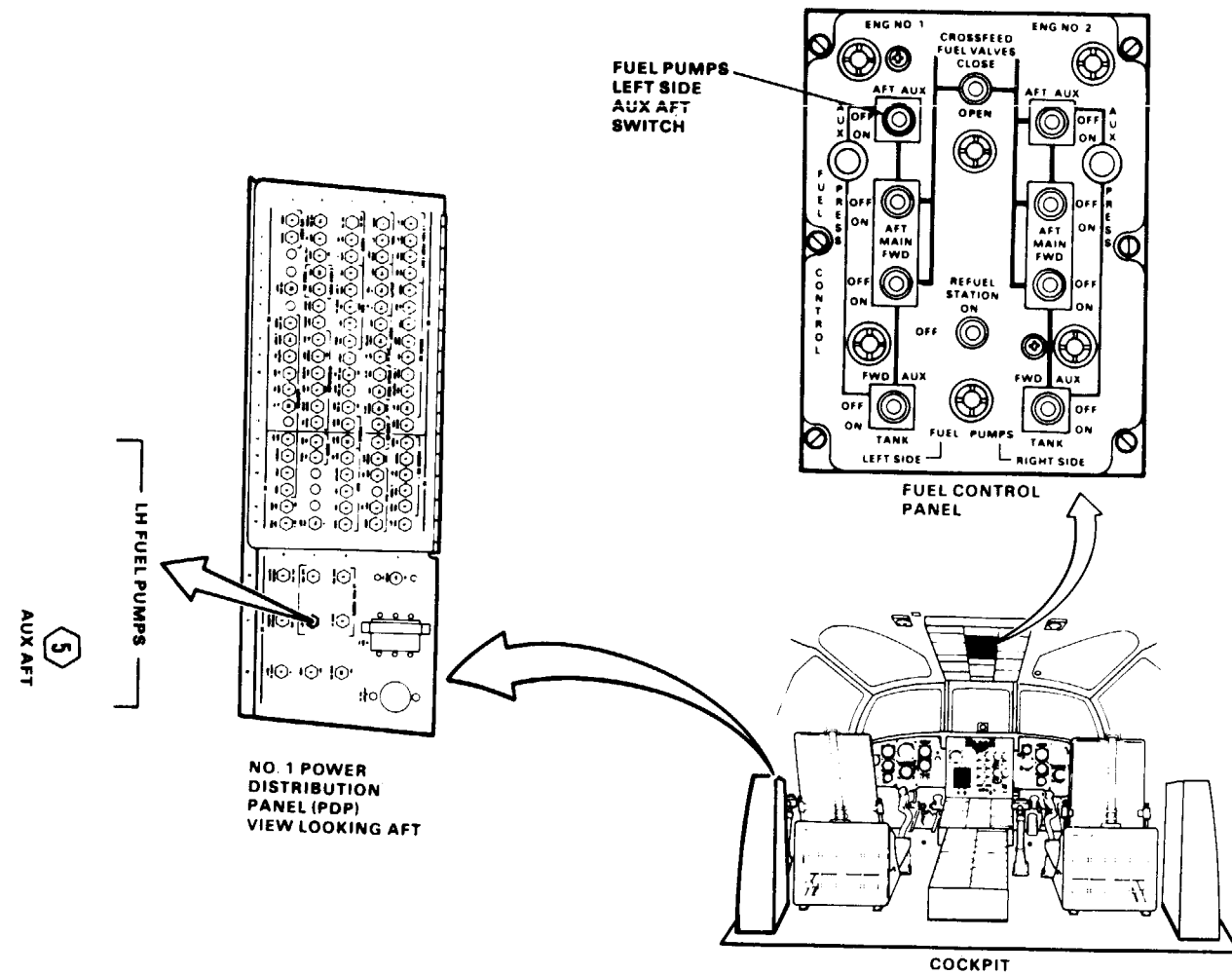

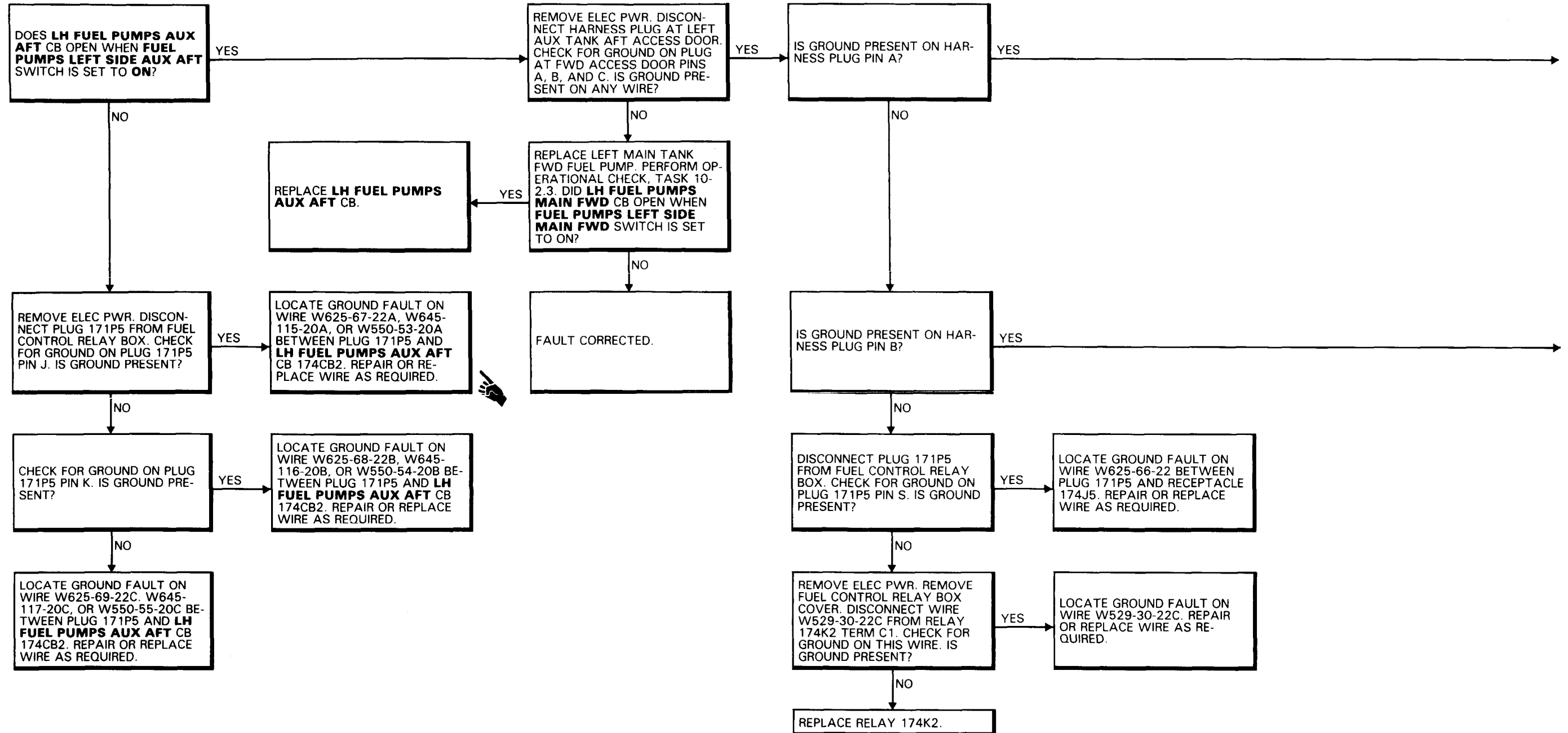

10-2.7 LH FUEL PUMPS AUX AFT CIRCUIT BREAKER WILL NOT STAY CLOSED (Continued)

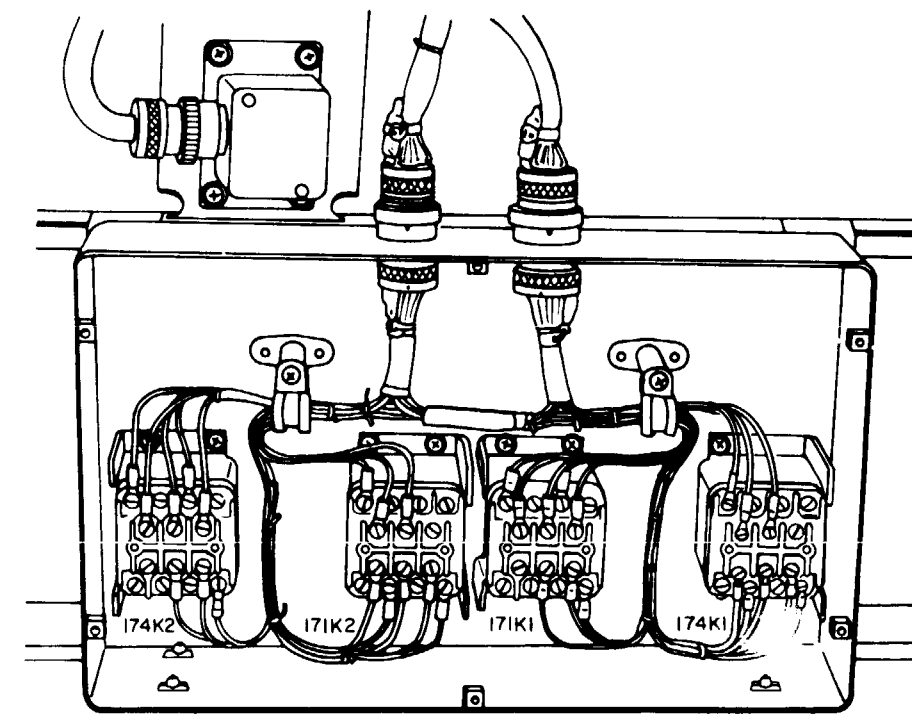
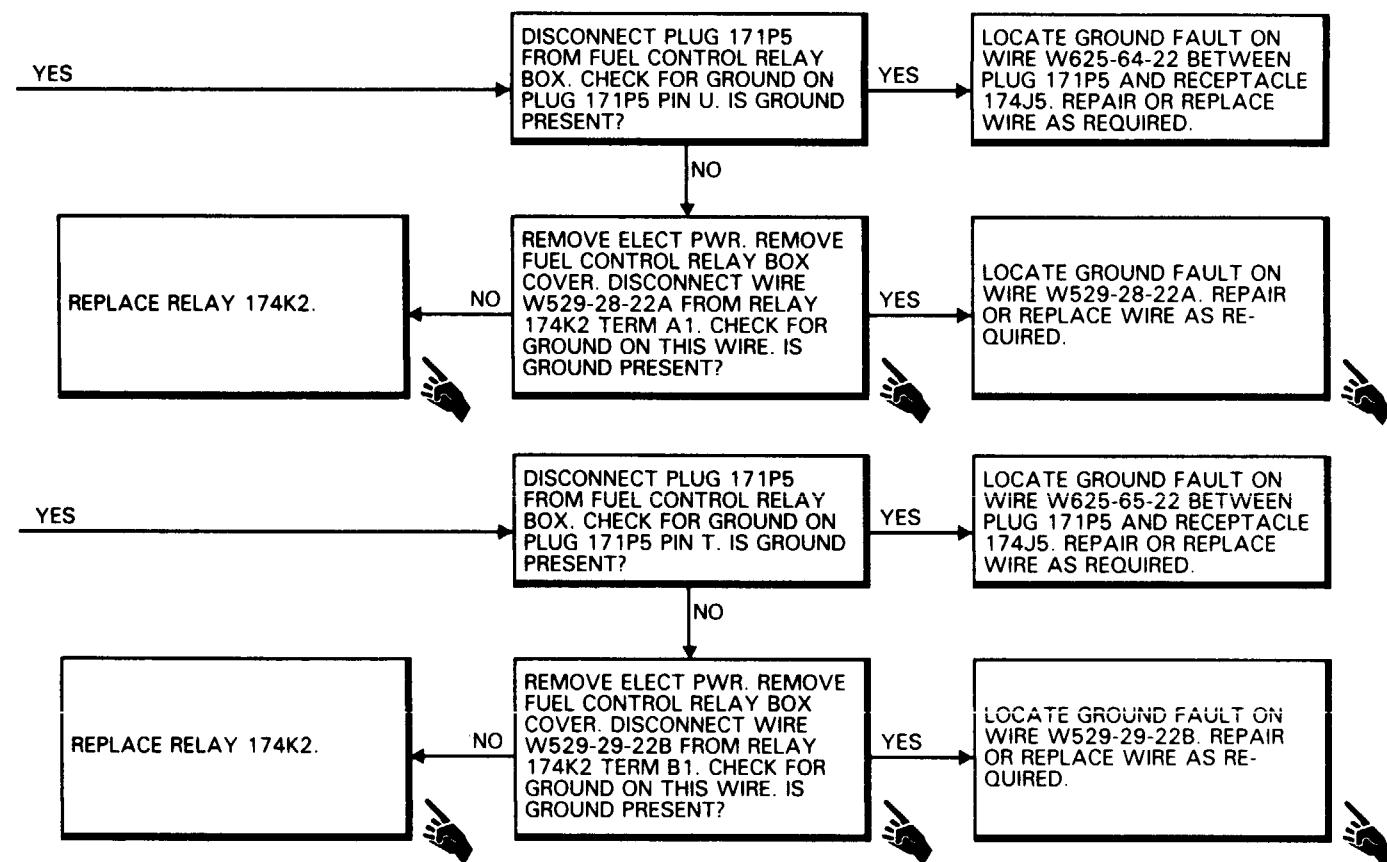

10-2.8 LH FUEL PUMP CONT AUX AFT CIRCUIT
NOT STAY CLOSED

FAULT ISOLATION PROCEDURE

INITIAL SETUP

Applicable Configurations:

All

Tools:

Electrical Repairer's Tool Kit,
NSN 5180-00-323-4915
Multimeter

Materials:

None

Personnel Required:

68F10 Aircraft Electrician
68F20 Aircraft Electrician

References:

TM 55-1520-240-23

Equipment Condition:

TM 55-1520-240-23:
Battery Connected
Electrical Power On
Hydraulic Power Off
Side Acoustical Blanket Removed Between
Sta 320 and 360

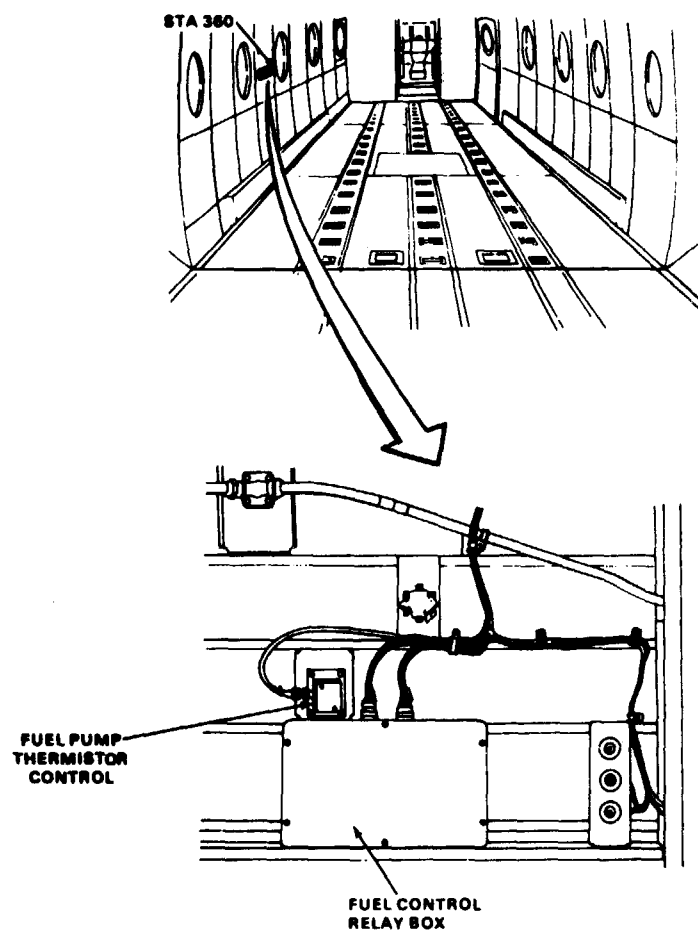

90 X 84

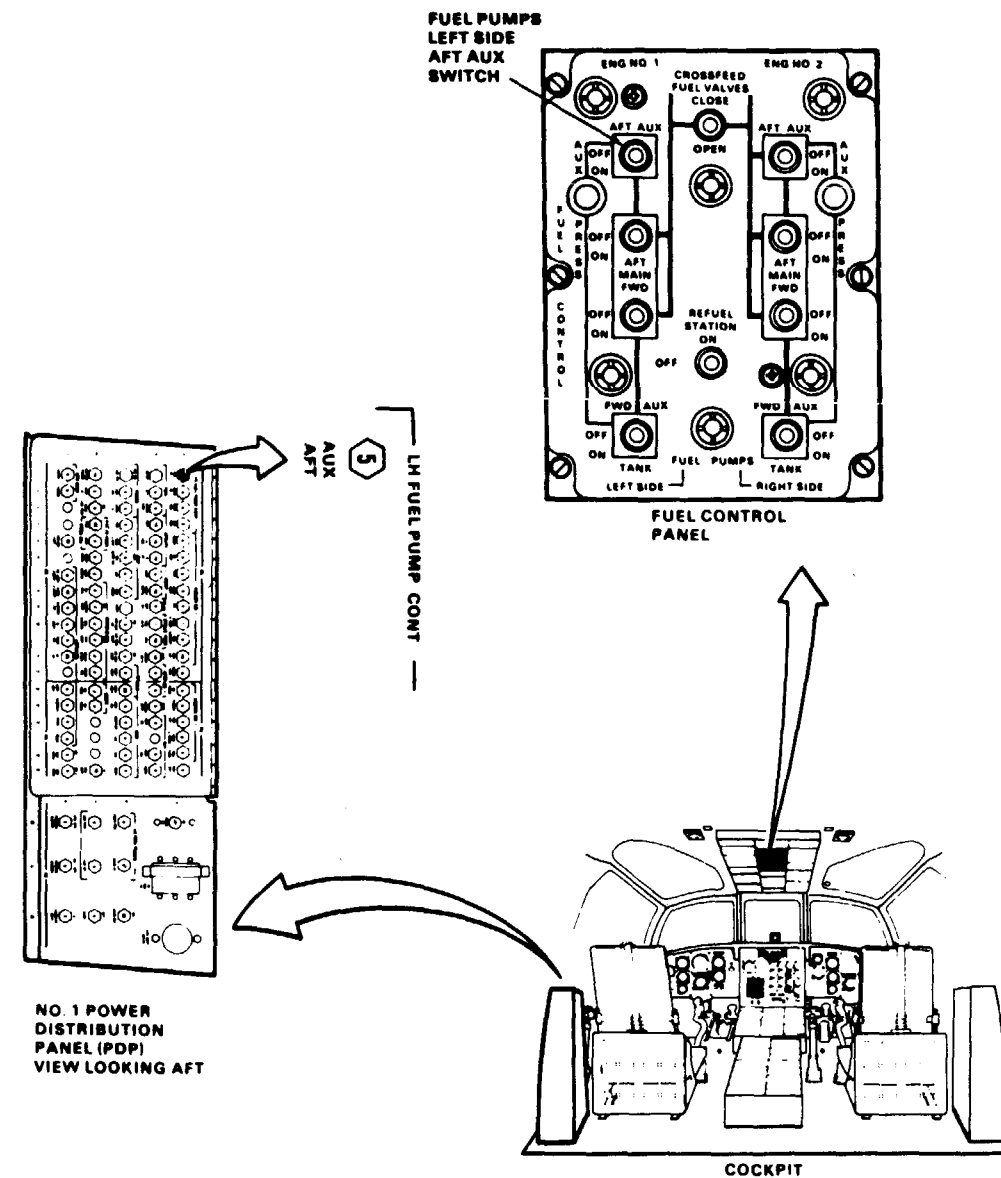

0145-11735-8PA

GO TO NEXT PAGE

10-2.8 LH FUEL PUMP CONT AUX AFT CIRCUIT BREAKER WILL NOT STAY CLOSED (Continued)

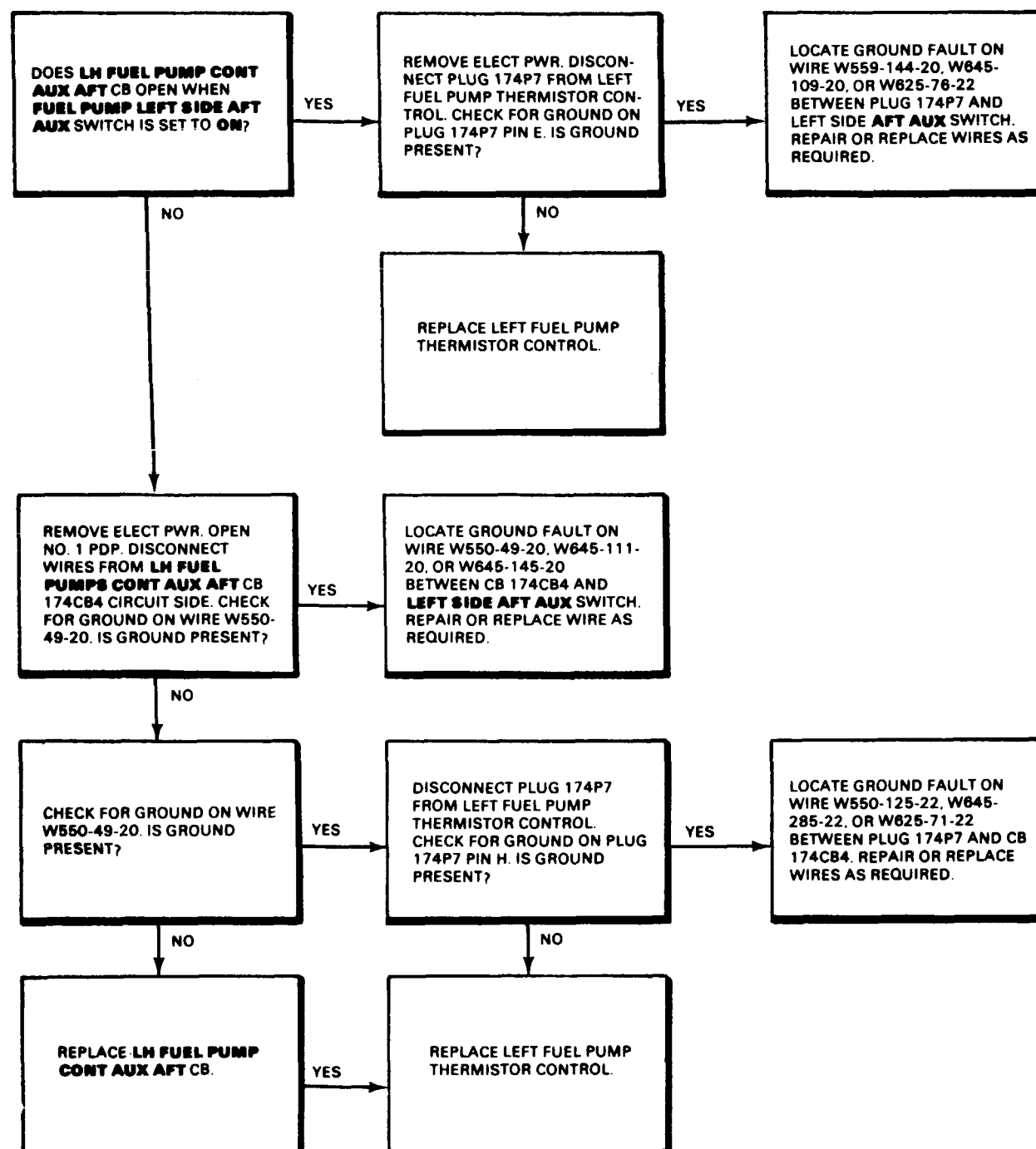

END OF TASK

FAULT ISOLATION PROCEDURE

INITIAL SETUP

Applicable Configurations:

All

Tools:

Electrical Repairer's Tool Kit,
NSN 5180-00-323-4915
Multimeter

Materials:

None

Personnel Required:

Aircraft Electrician (2)

References:

TM 55-1520-240-23

Equipment Condition:

TM 55-1520-240-23:
Battery Connected
Electrical Power On
Hydraulic Power Off
Side Acoustical Blanket Removed Between Sta
320 and 360

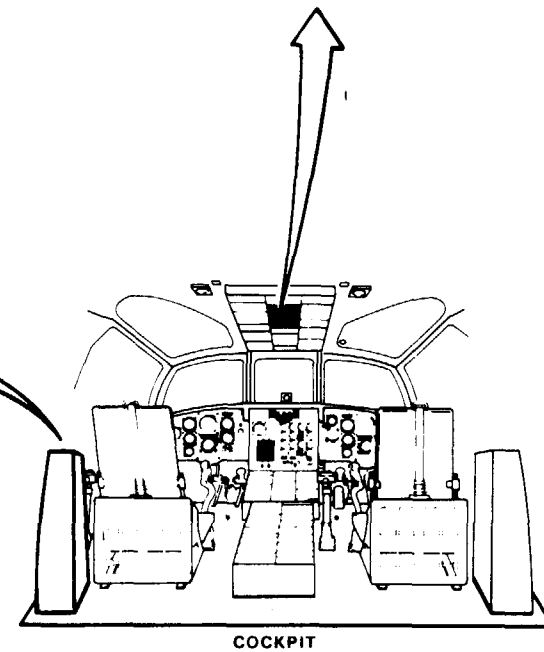
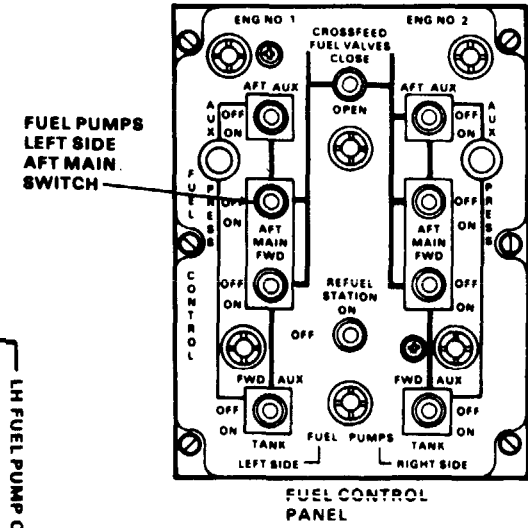
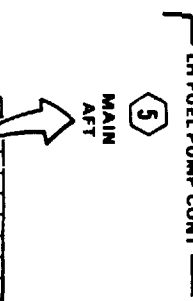
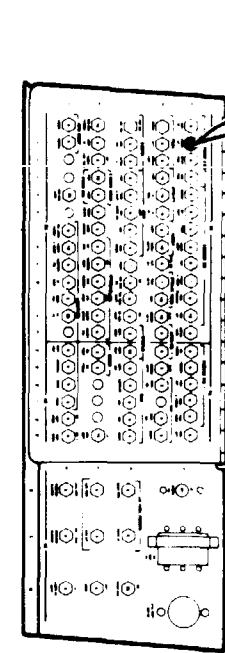
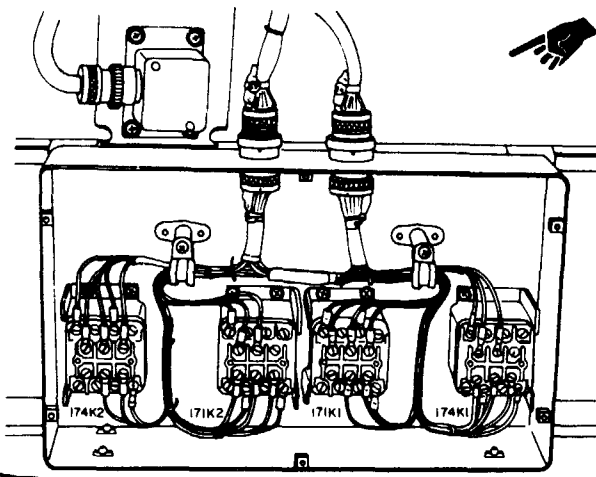
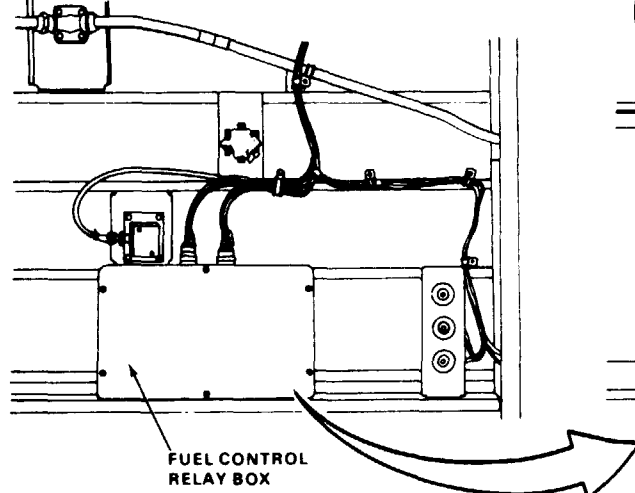
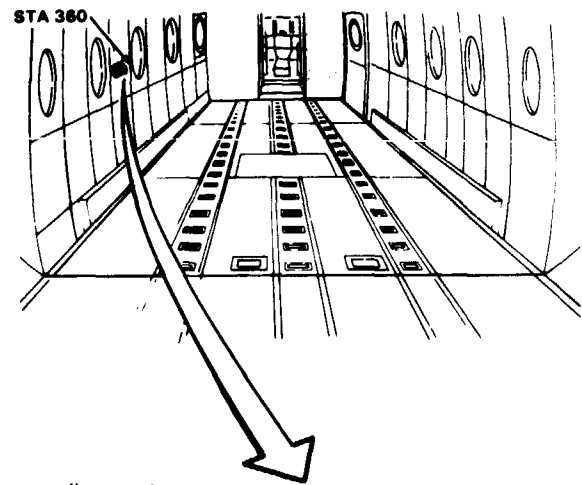

10-2.9 LH FUEL PUMP CONT MAIN AFT CIRCUIT BREAKER WILL NOT STAY CLOSED (Continued)

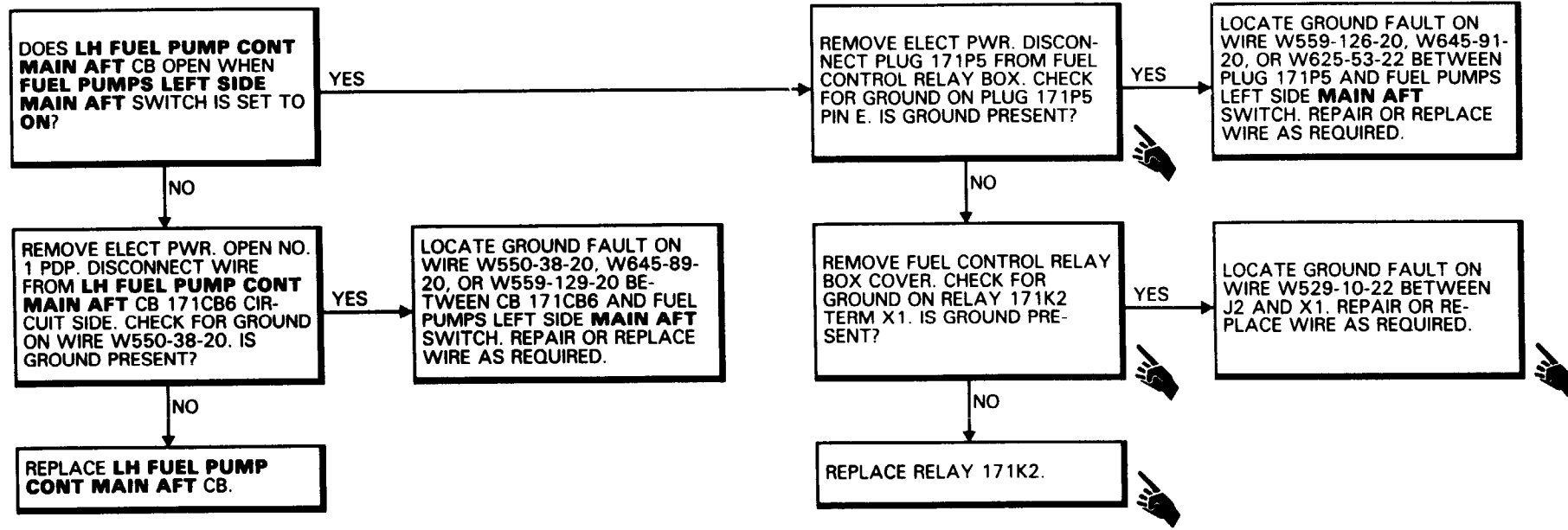

FAULT ISOLATION PROCEDURE

INITIAL SETUP

Applicable Configurations:

All

Tools:

- Electrical Repairer's Tool Kit,
- NSN 5180-00-323-4915
- Multimeter

Materials:

None

Personnel Required:

- Aircraft Electrician (2)

References:

TM 55-1520-240-23

Equipment Condition:

- TM 55-1520-240-23:
- Battery Connected
- Electrical Power On
- Hydraulic Power Off
- Side Acoustical Blanket Removed Between Sta 320 and 360

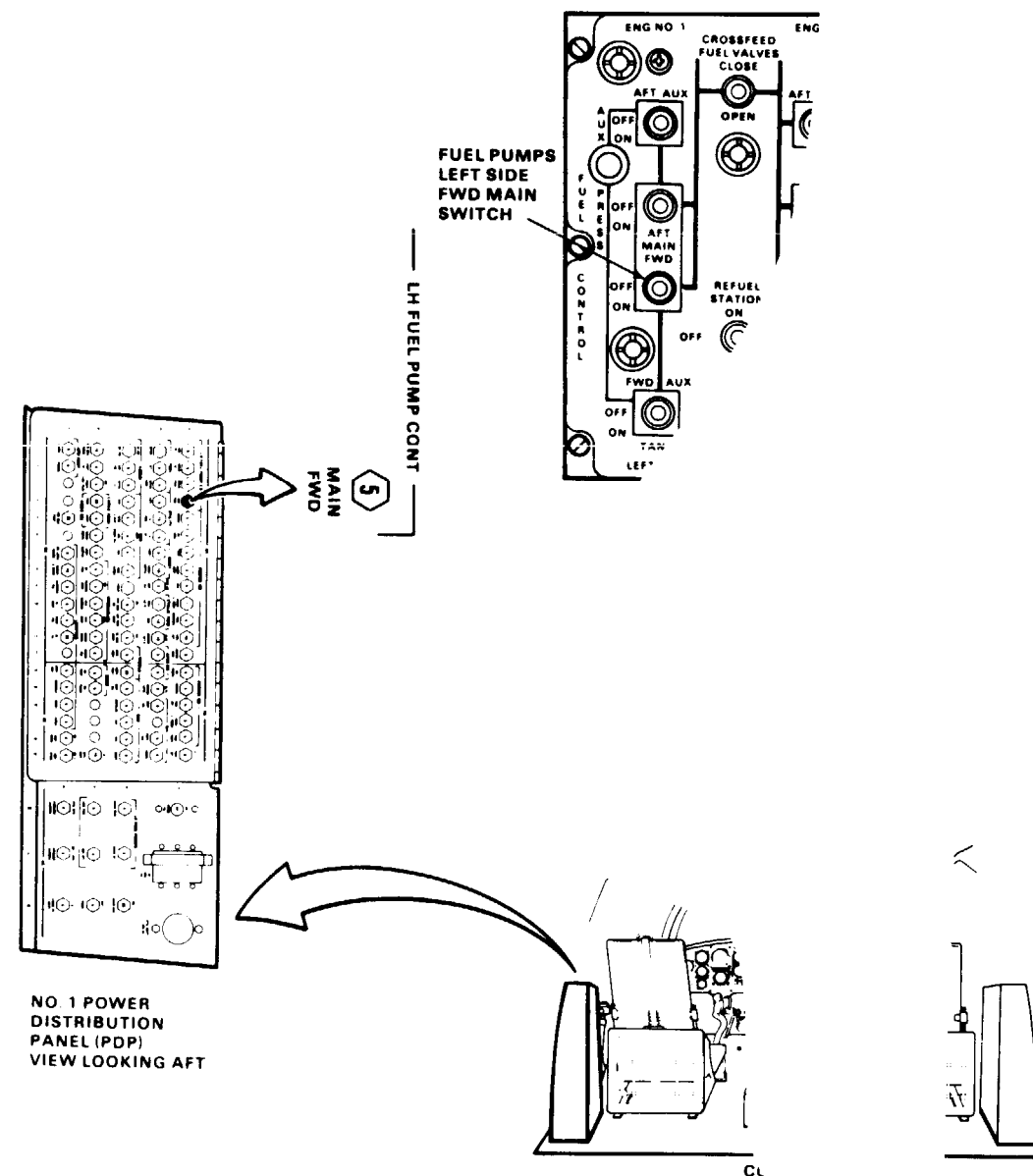
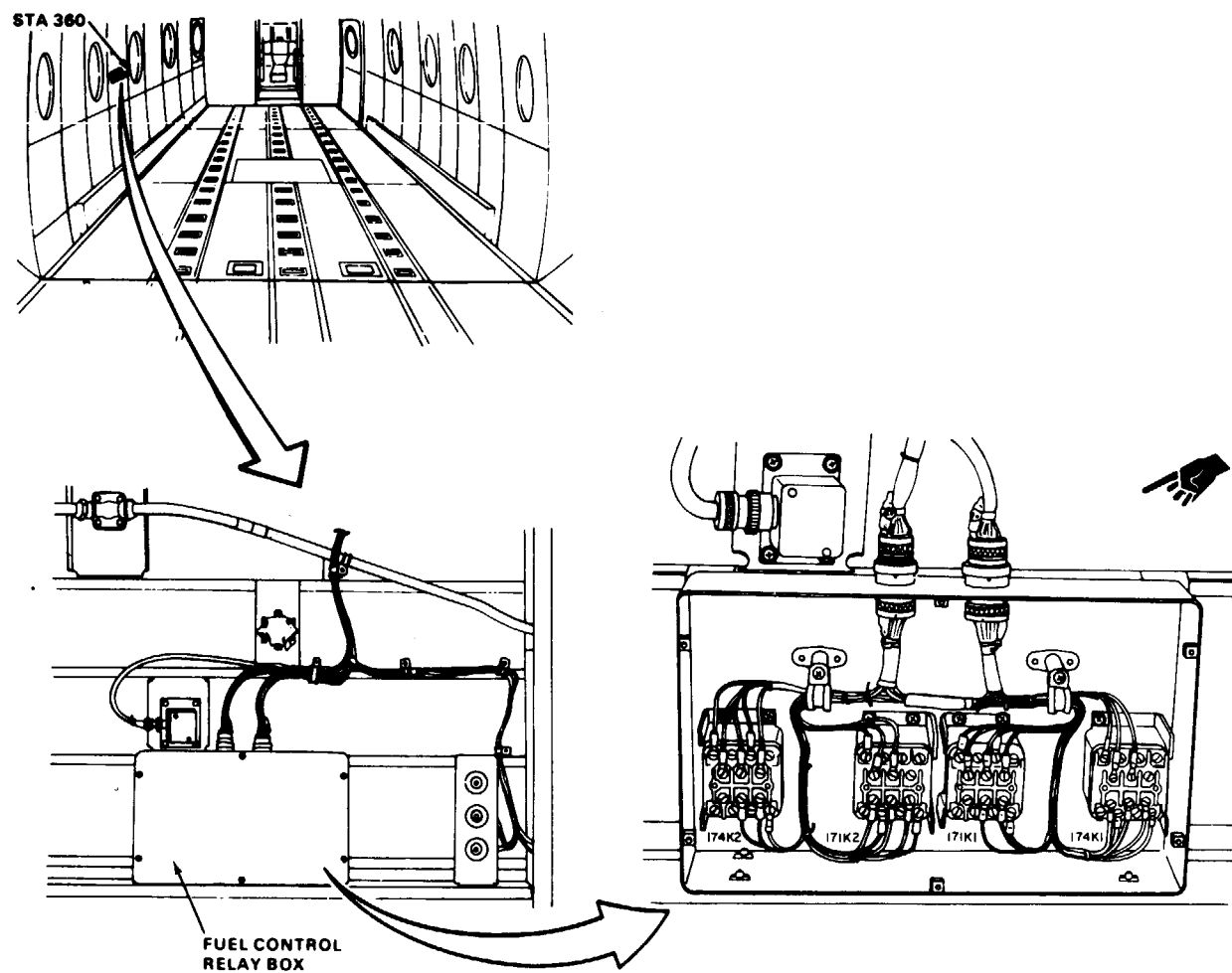

9622

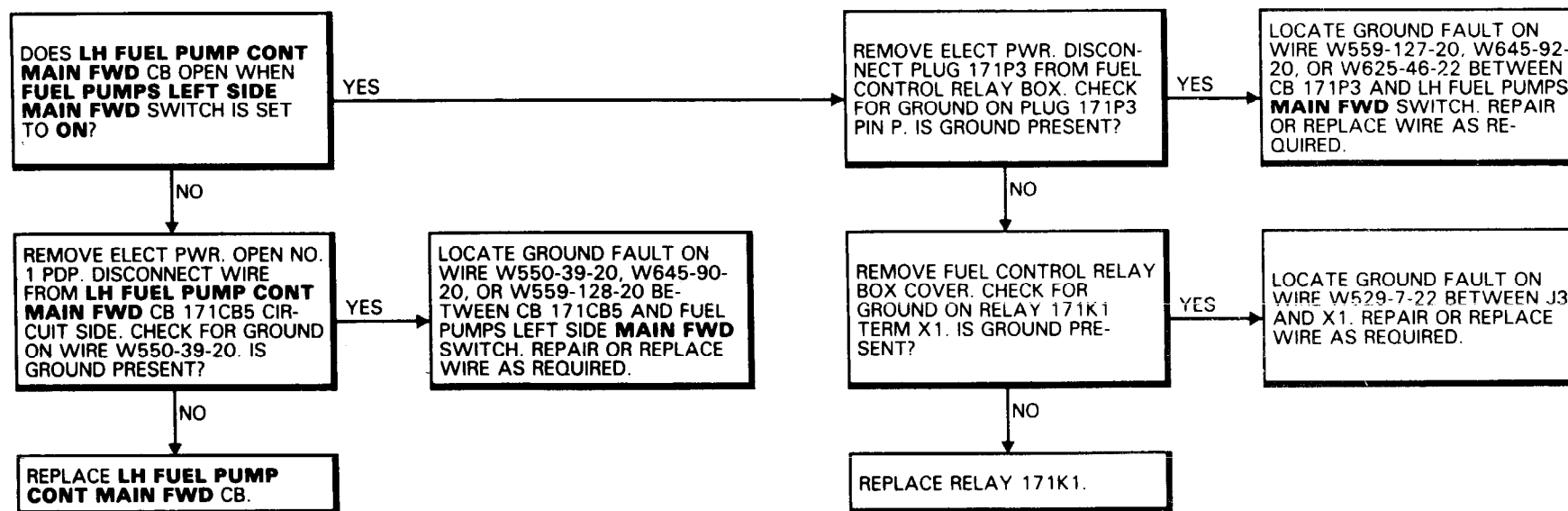

10-2.11 LH FUEL PUMP CONT AUX FWD CIRCUIT BREAKER
WILL NOT STAY CLOSED

FAULT ISOLATION PROCEDURE

INITIAL SETUP

Applicable Configurations:
All

Tools:
Electrical Repairer's Tool Kit,
NSN 5180-00-323-4915
Multimeter

Materials:
None

Personnel Required:
Aircraft Electrician (2)

References:
TM 55-1520-240-23

Equipment Condition:
TM 55-1520-240-23:
Battery Connected
Electrical Power On
Hydraulic Power Off
Side Acoustical Blanket Removed Between Sta
320 and 360

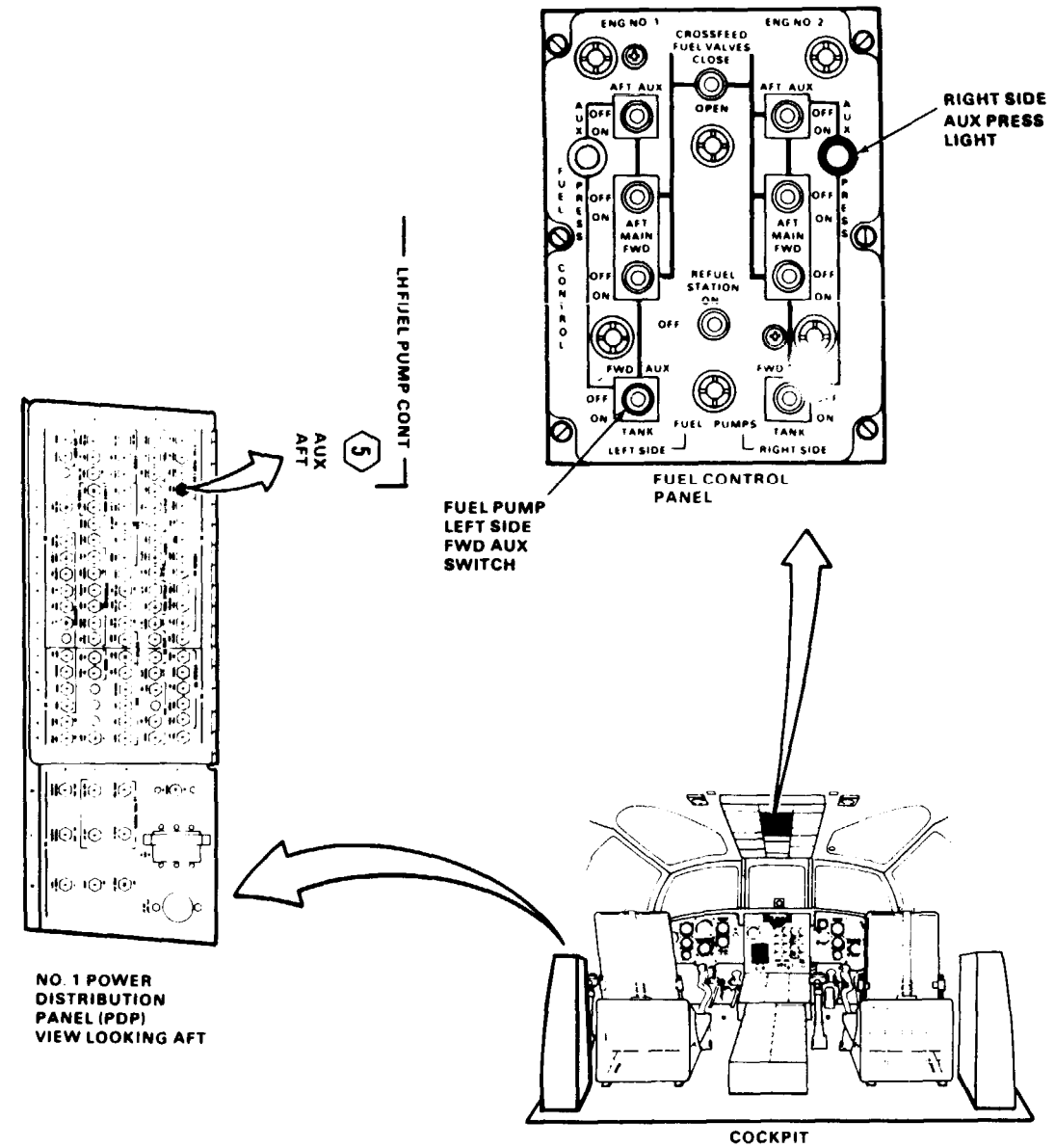
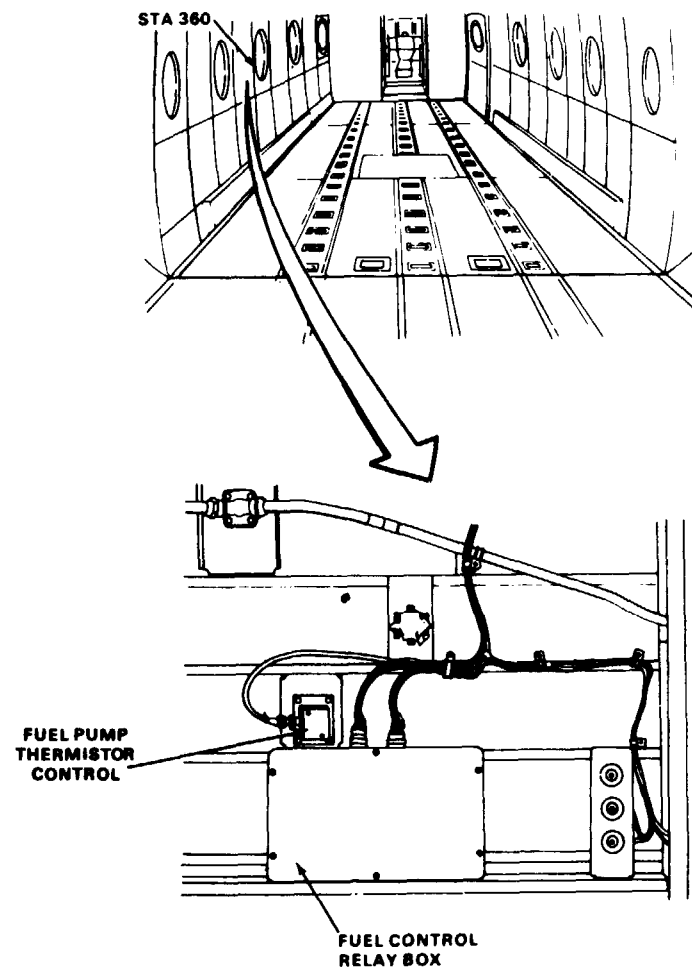

10-2.11 LH FUEL PUMP CONT AUX FWD CIRCUIT BREAKER
WILL NOT STAY CLOSED (Continued)

10-2.11

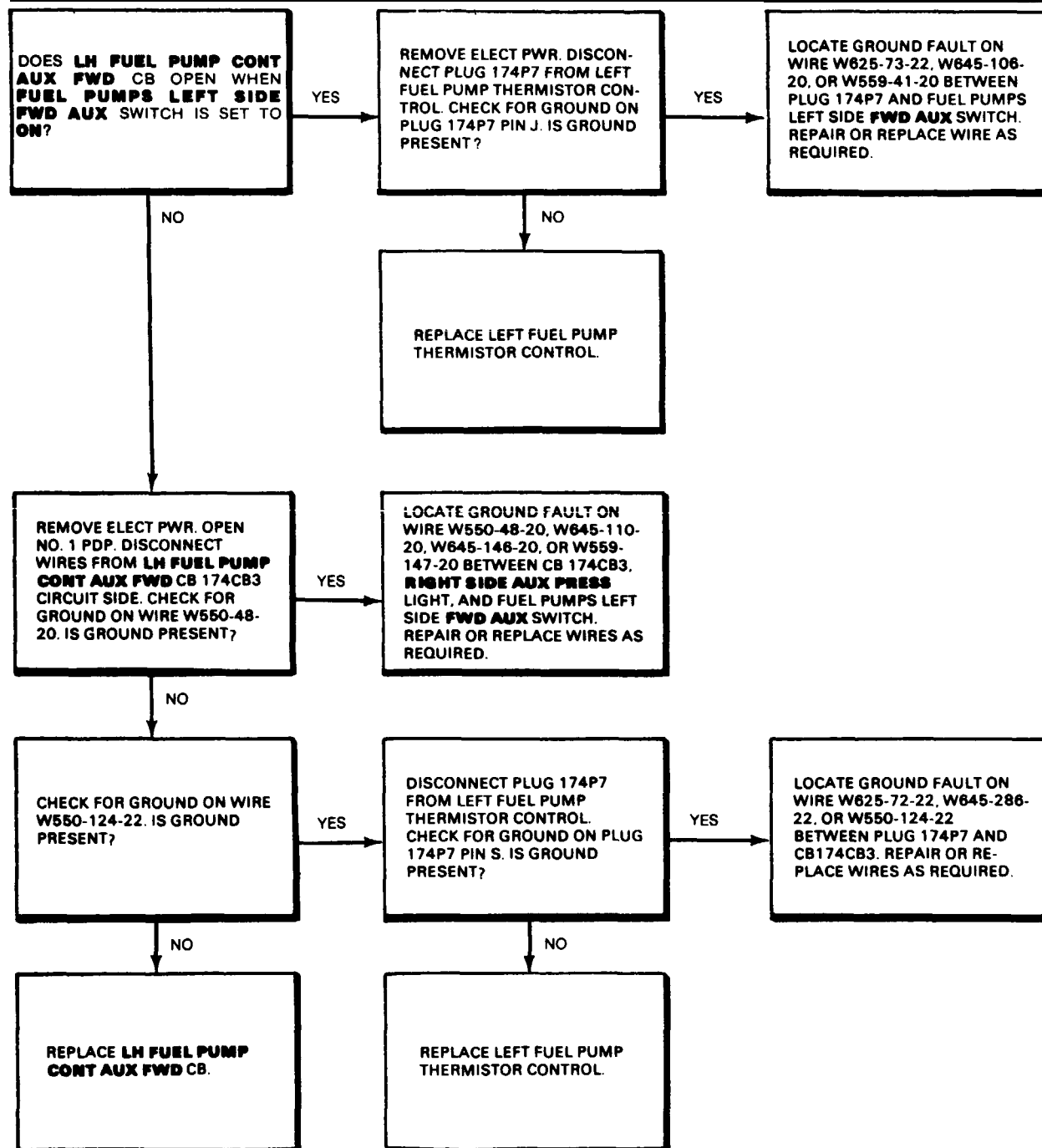

END OF TASK

FAULT ISOLATION PROCEDURE

INITIAL SETUP

Applicable Configurations:

All

Tools:

- Electrical Repairer's Tool Kit, NSN 5180-00-323-4915
- Multimeter

Materials:

None

Personnel Required:

Aircraft Electrician (2)

References:

TM 55-1520-240-23

Equipment Condition:

- TM 55-1520-240-23:
 - Battery Connected
 - Electrical Power On
 - Hydraulic Power Off
 - Side Acoustical Blanket Removed Between Sta 320 and 360
 - Right Forward Landing Gear Access Panel Open

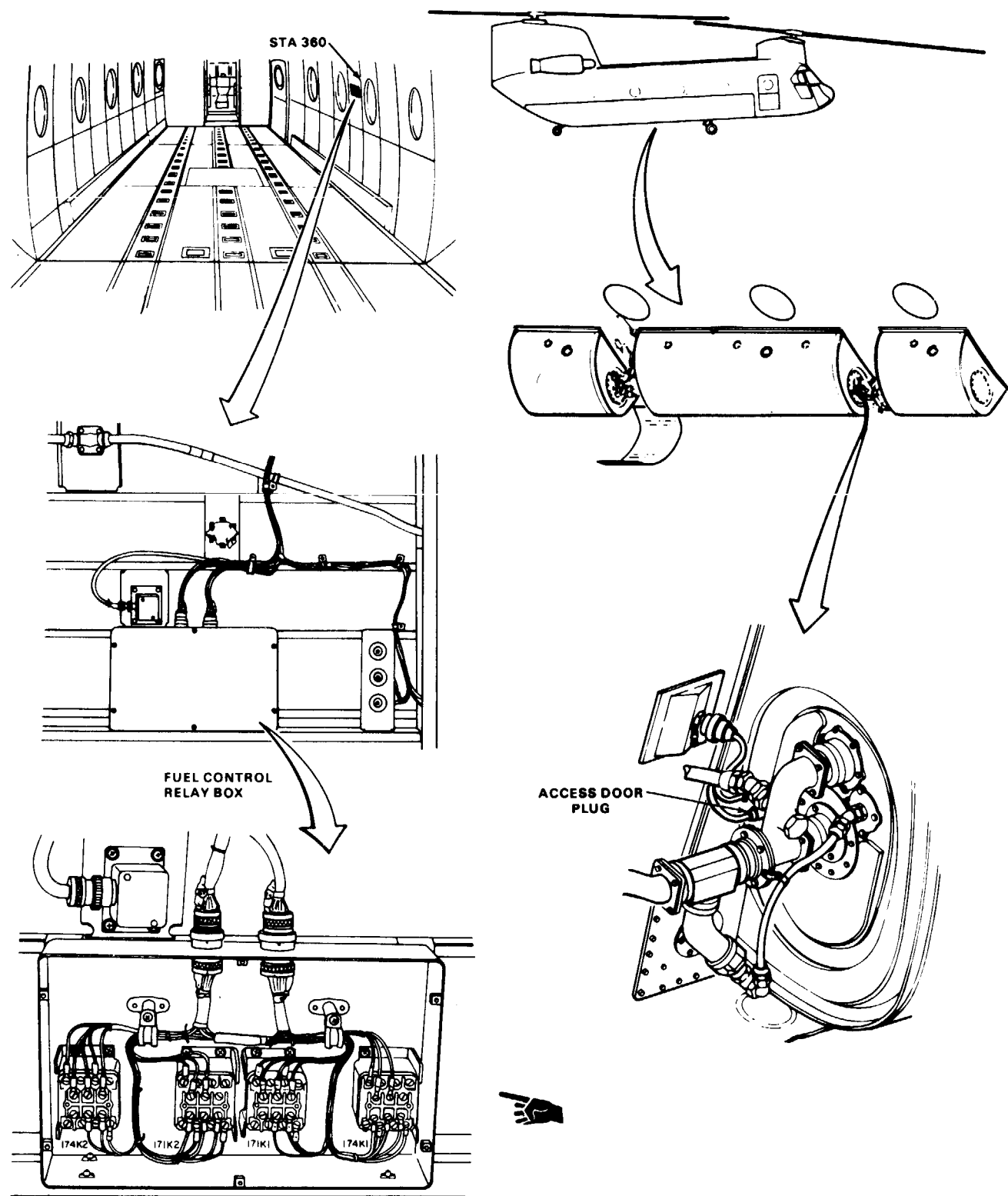
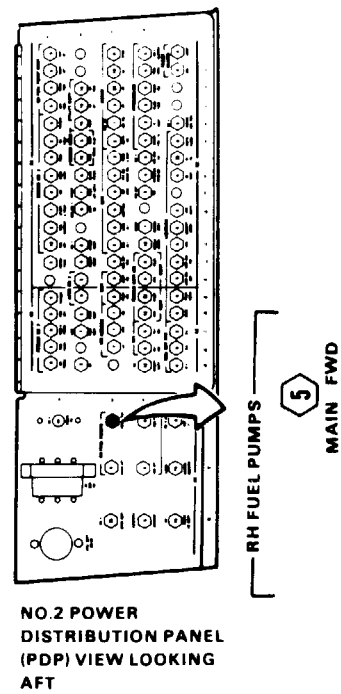
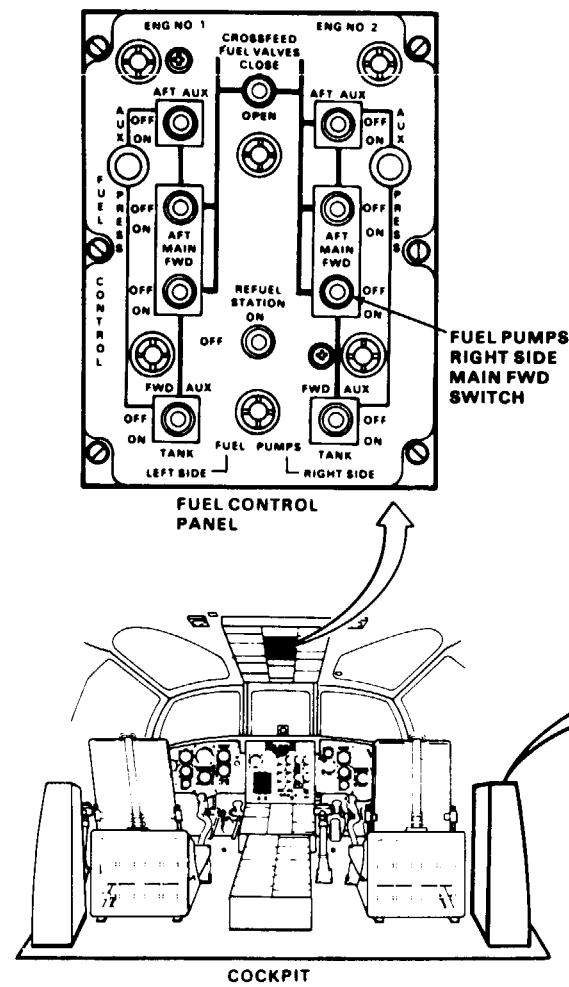

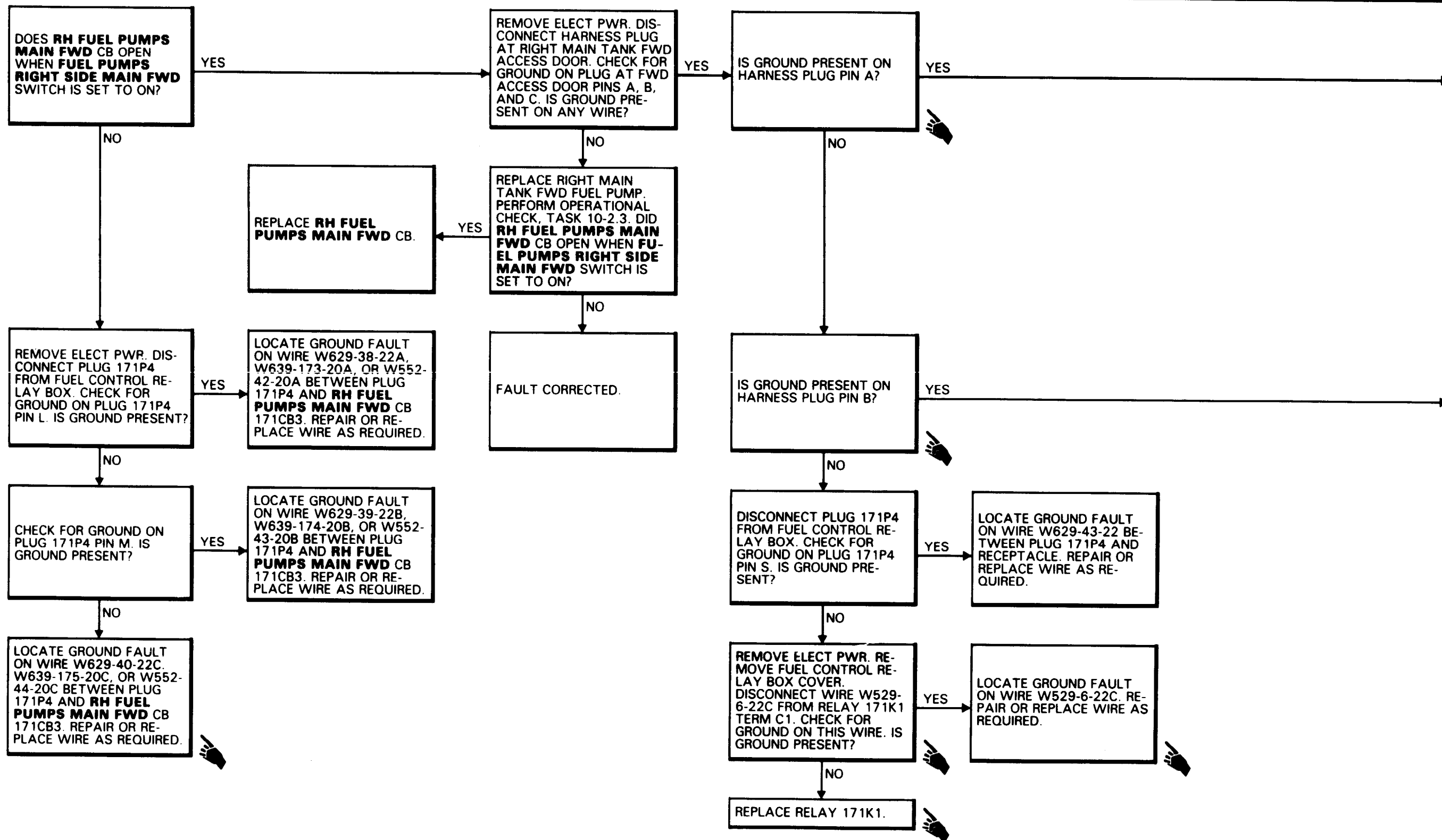

10-2.12 RH FUEL PUMP MAIN FWD CIRCUIT BREAKER WILL NOT STAY CLOSED (Continued)

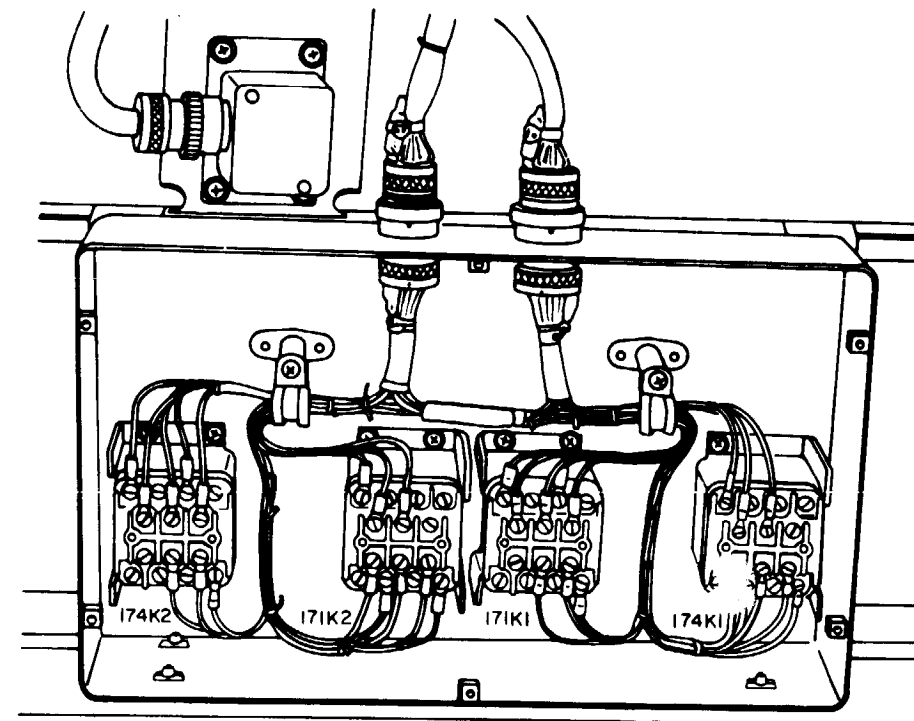
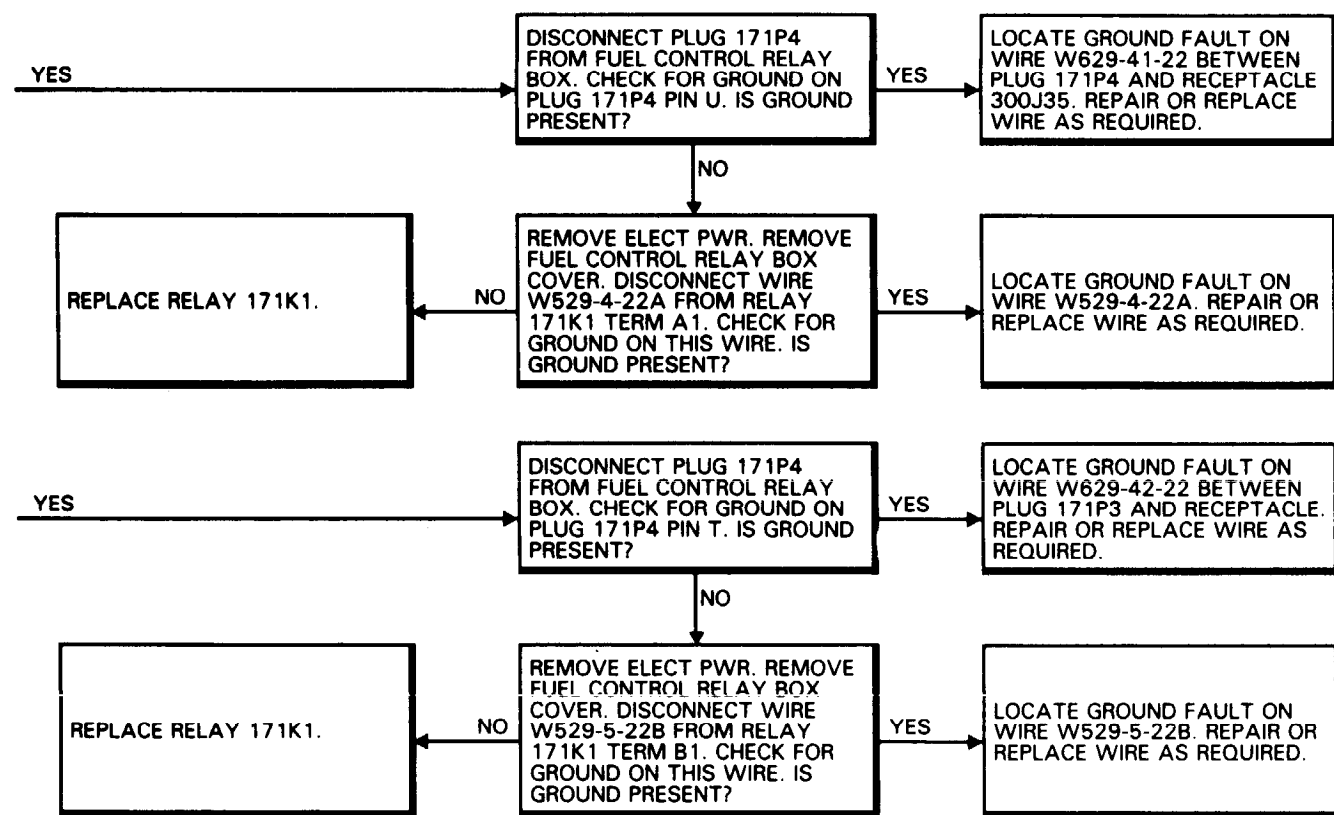

FAULT ISOLATION PROCEDURE

INITIAL SETUP

Applicable Configurations:

All

Tools:

- Electrical Repairer's Tool Kit,
NSN 5180-00-323-4915
- Multimeter

Materials:

None

Personnel Required:

Aircraft Electrician (2)

References:

TM 55-1520-240-23

Equipment Condition:

- TM 55-1520-240-23:
- Battery Connected
- Electrical Power On
- Hydraulic Power Off
- Side Acoustical Blanket Removed Between Sta 320 and 360
- Right Aft Intertank Access Panel Open

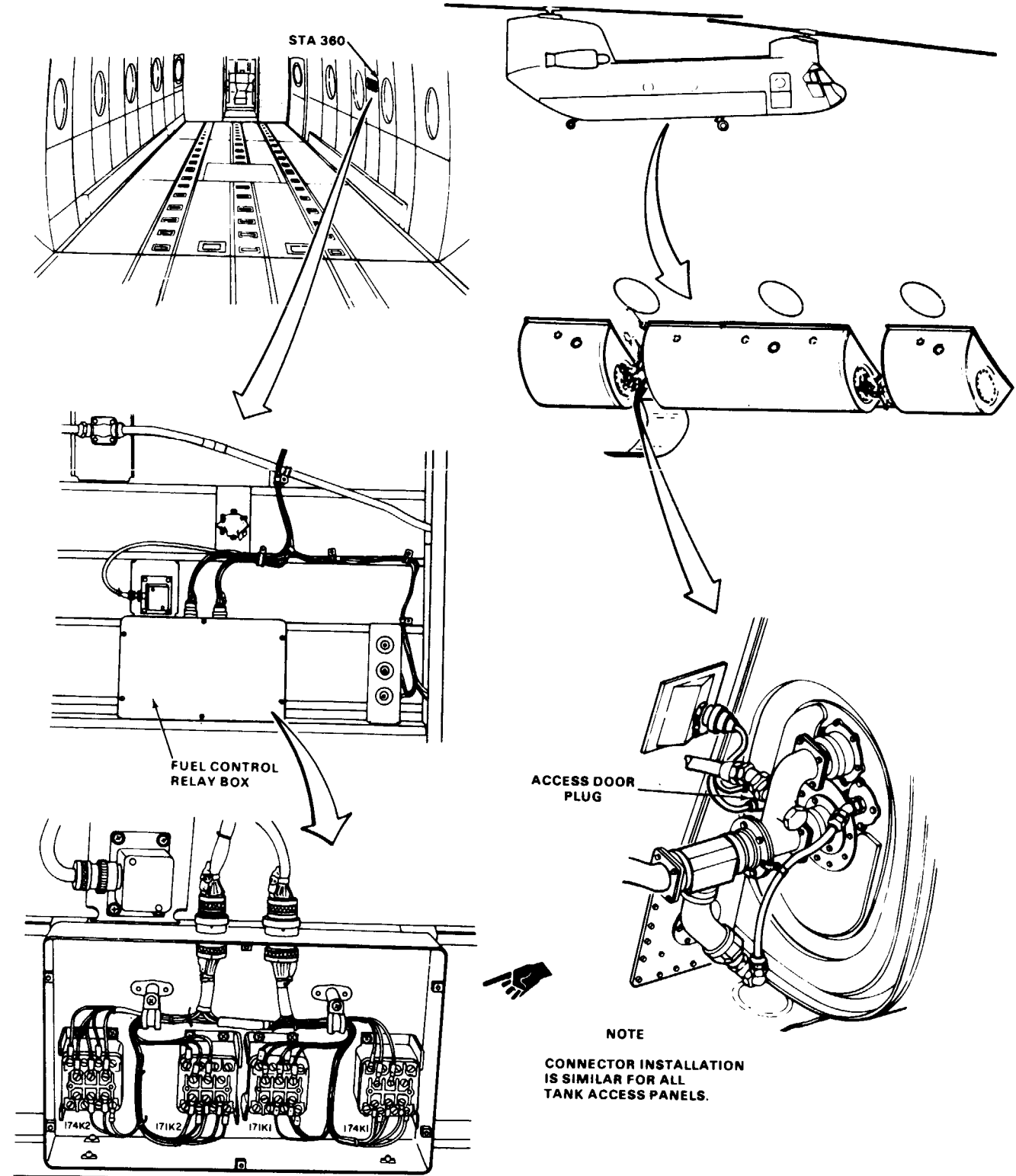
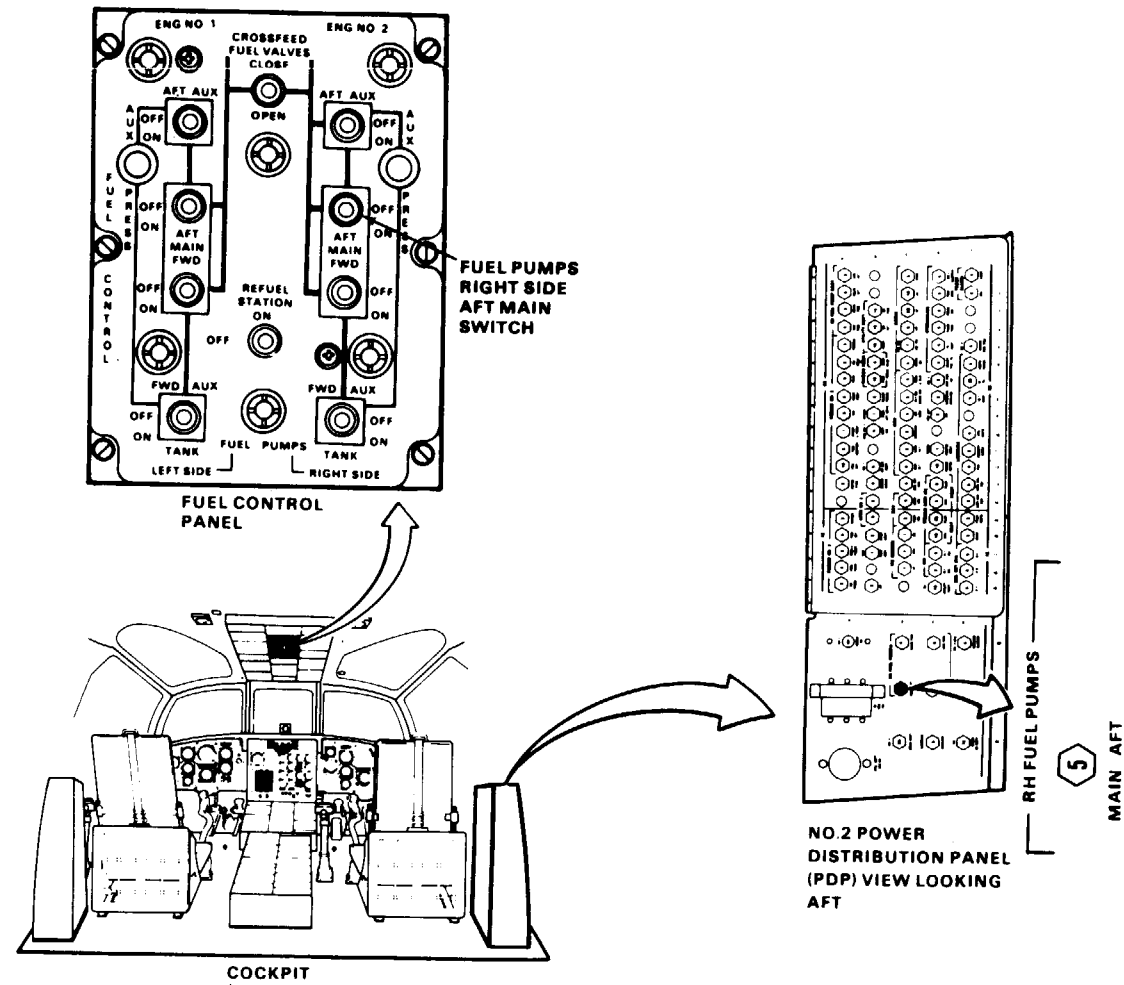

10-2.13 RH FUEL PUMP MAIN AFT CIRCUIT BREAKER WILL NOT STAY CLOSED (Continued)

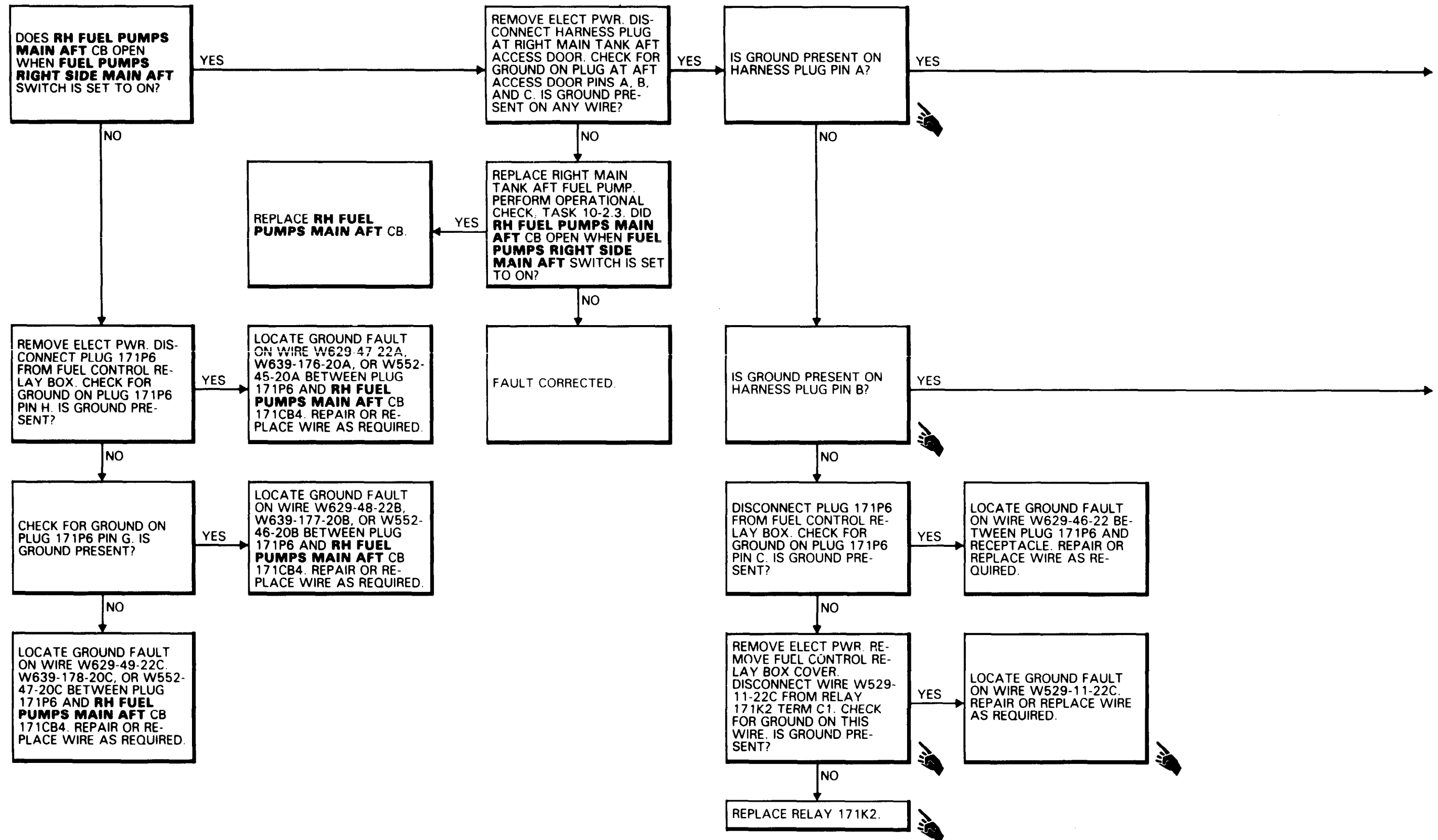

10-2.13 RH FUEL PUMP MAIN AFT CIRCUIT BREAKER WILL NOT STAY CLOSED (Continued)

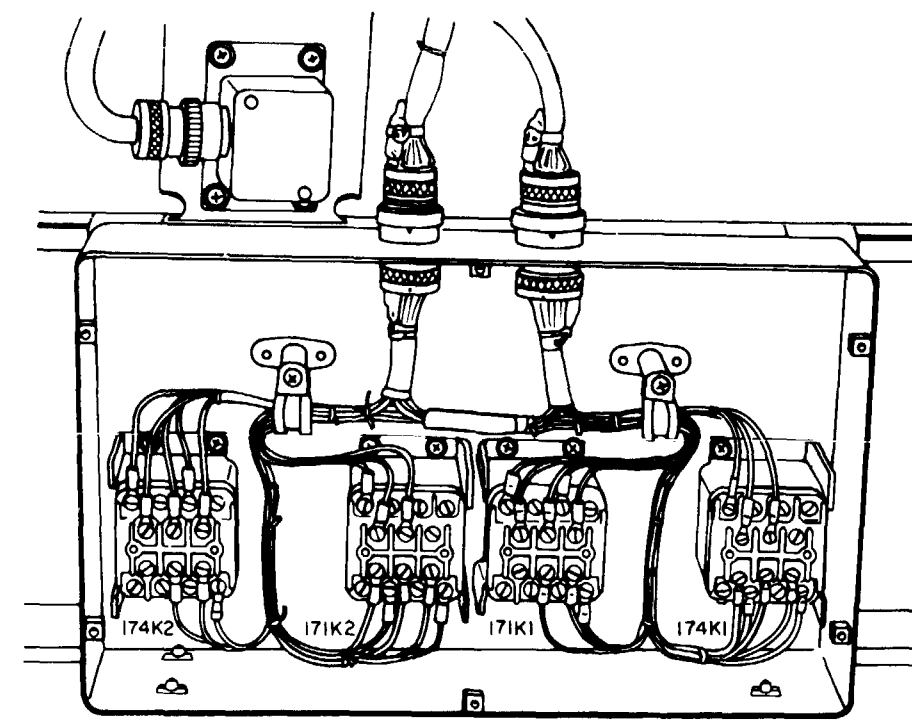
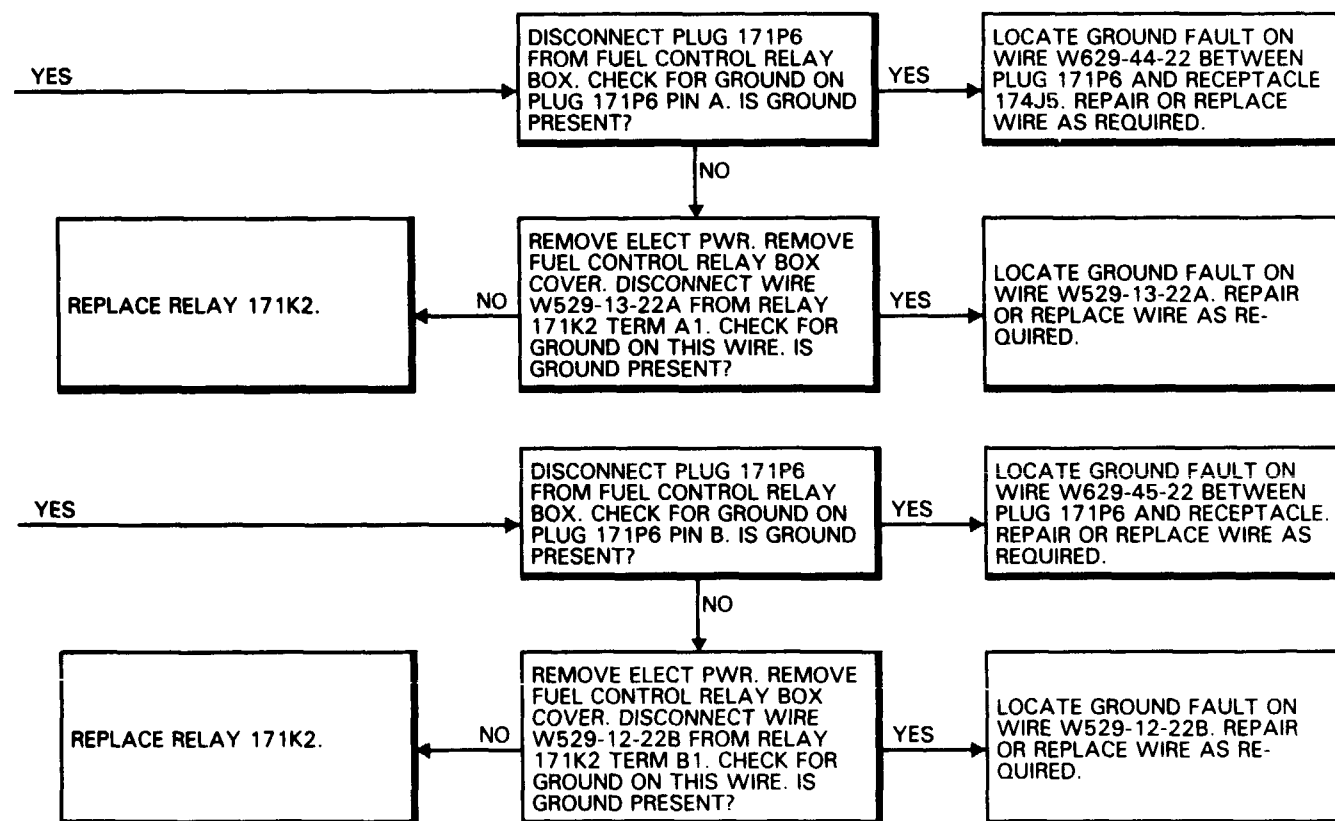

FAULT ISOLATION PROCEDURE

INITIAL SETUP

Applicable Configurations:

All

Tools:

- Electrical Repairer's Tool Kit,
NSN 5180-00-323-4915
- Multimeter

Materials:

None

Personnel Required:

Aircraft Electrician (2)

References:

TM 55-1520-240-23

Equipment Condition:

- TM 55-1520-240-23:
- Battery Connected
- Electrical Power On
- Hydraulic Power Off
- Side Acoustical Blanket Removed Between Sta 320 and 360
- Right Forward Landing Gear Access Panel Open

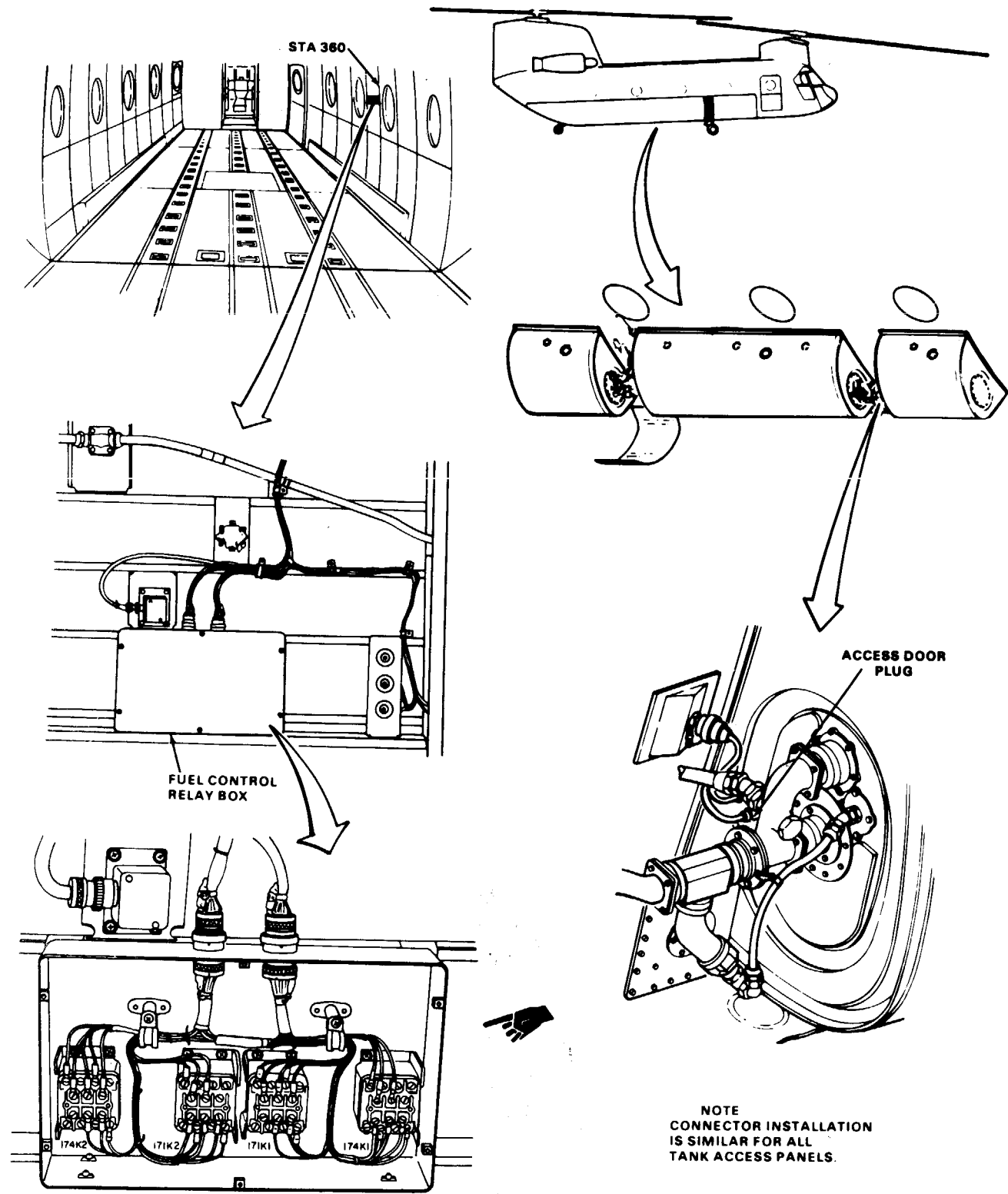
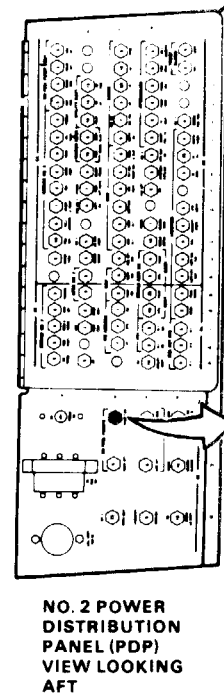
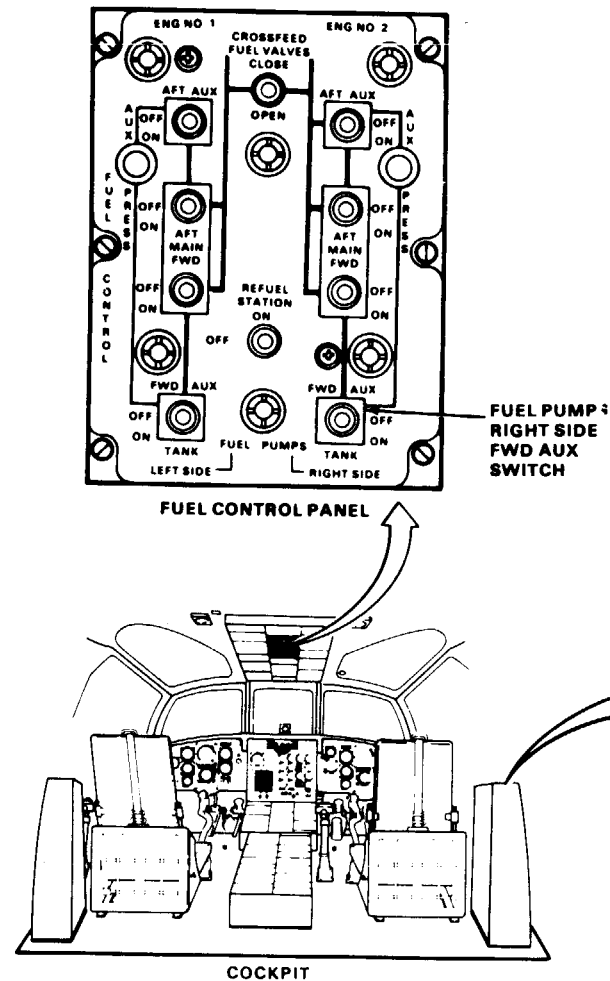

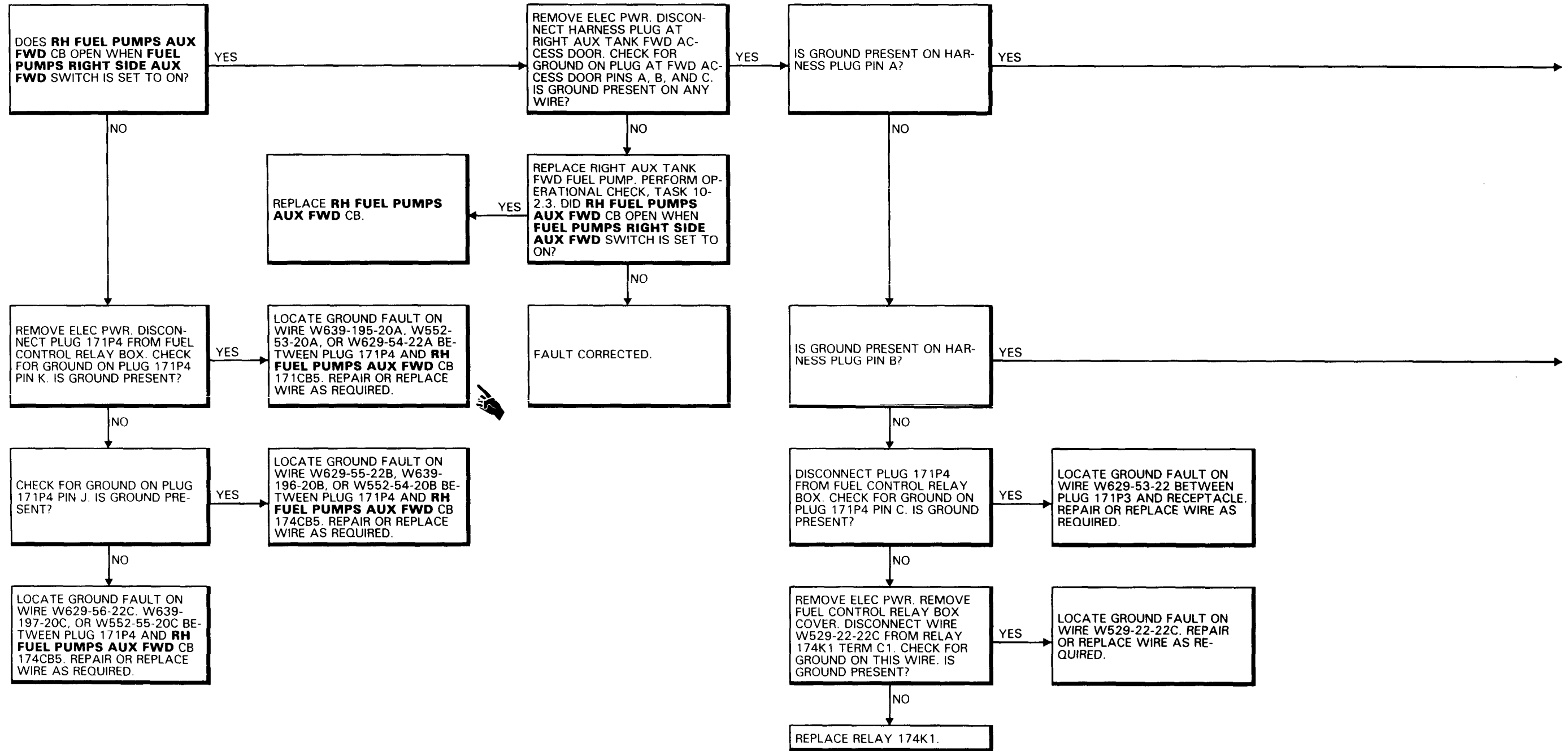

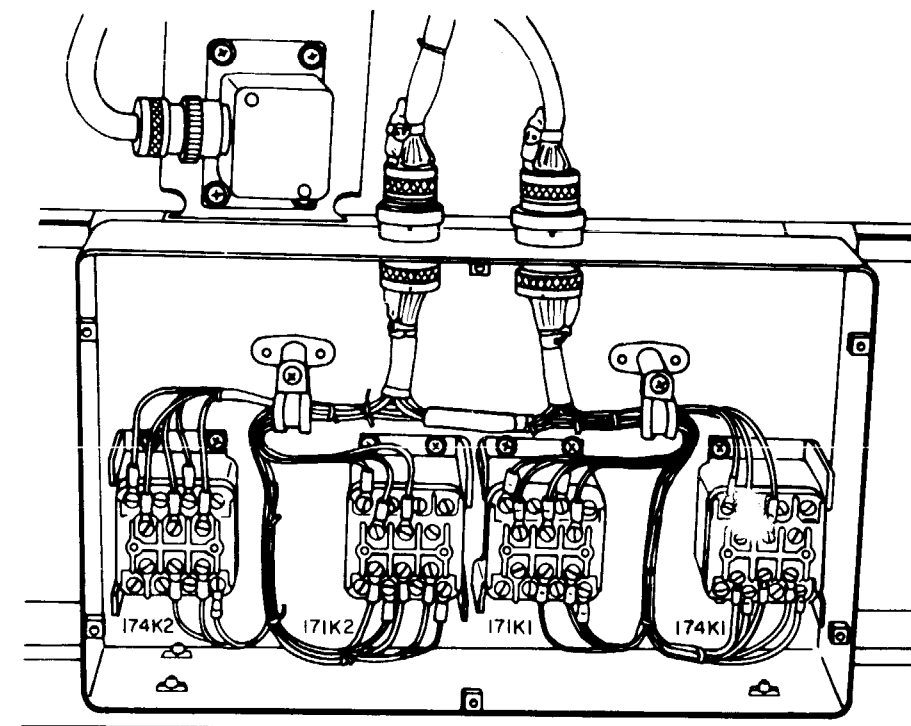
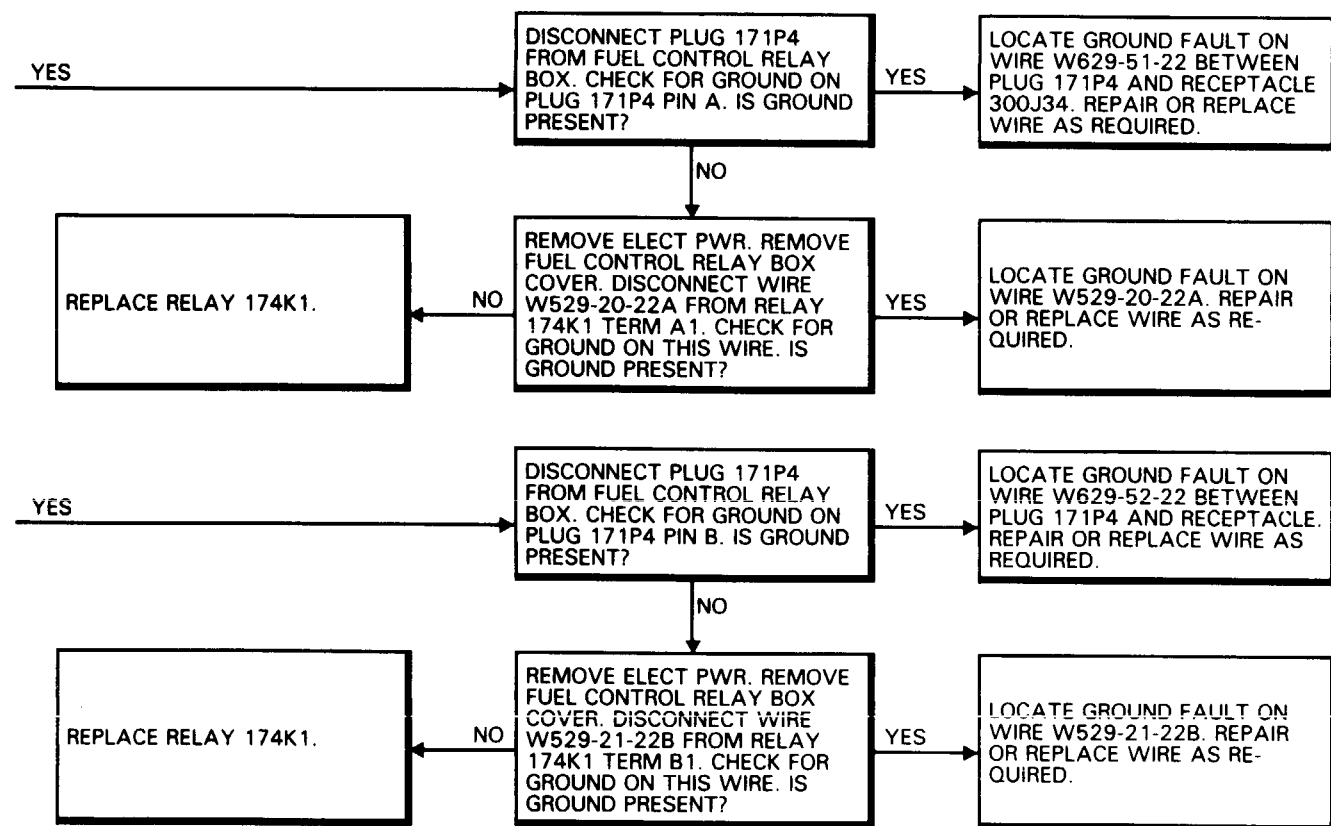

FAULT ISOLATION PROCEDURE

INITIAL SETUP

Applicable Configurations:

All

Tools:

Electrical Repairer's Tool Kit,
NSN 5180-00-323-4915
Multimeter

Materials:

None

Personnel Required:

Aircraft Electrician (2)

References:

TM 55-1520-240-23

Equipment Condition:

TM 55-1520-240-23:
Battery Connected
Electrical Power On
Hydraulic Power Off
Side Acoustical Blanket Removed Between Sta
320 and 360
Right Aft Intertank Access Panel Open

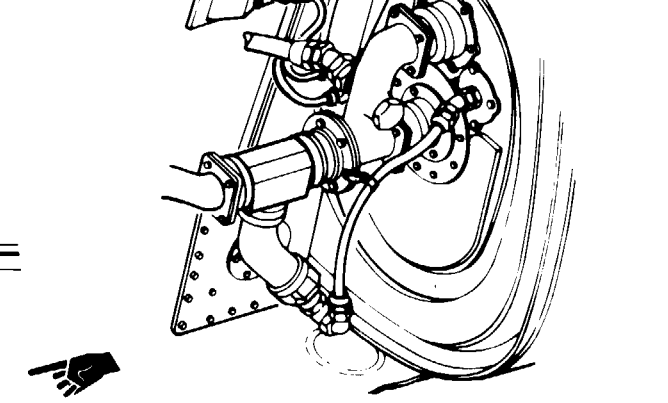
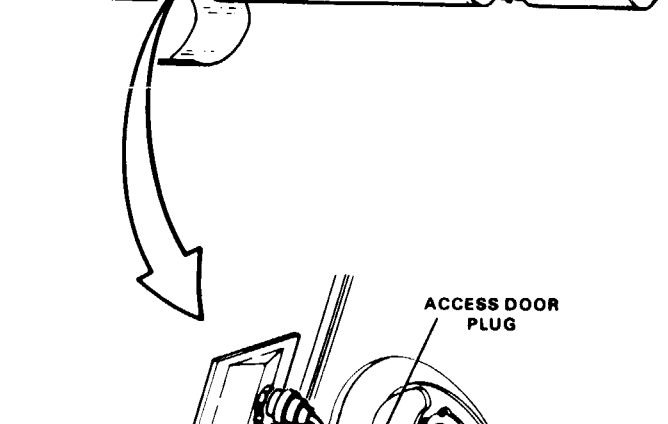
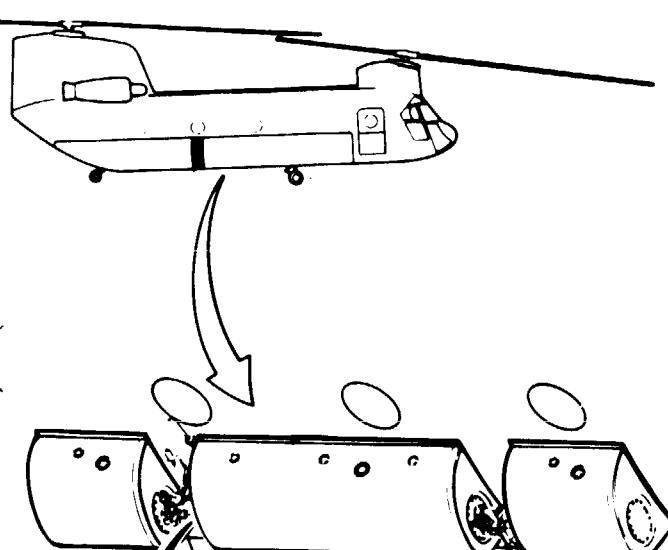
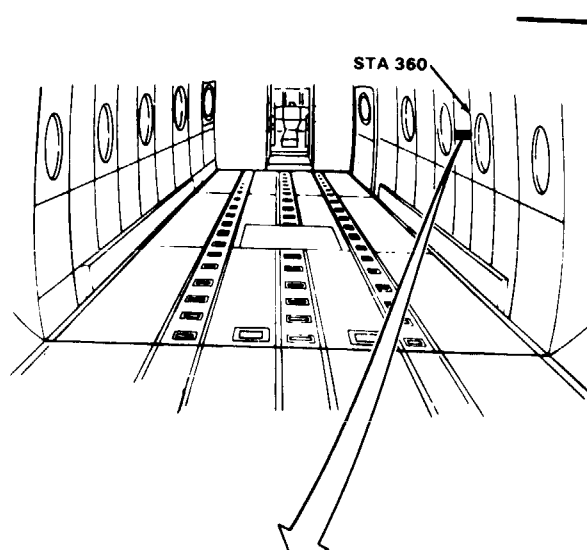
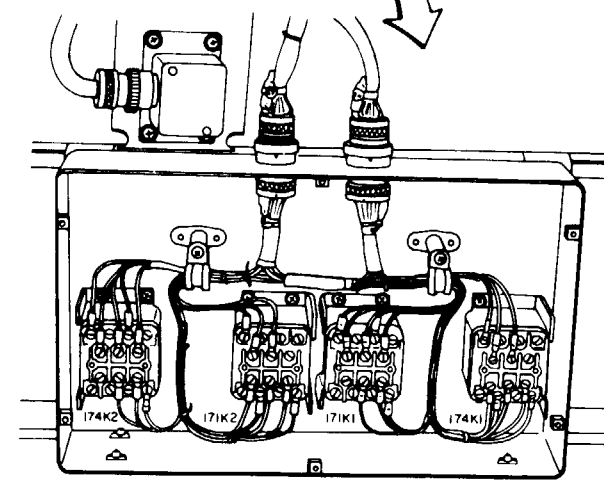
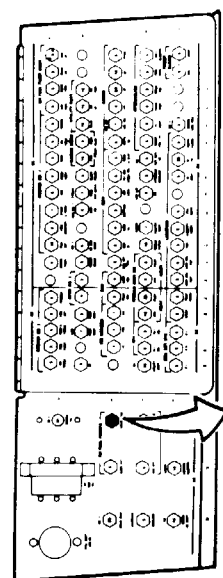
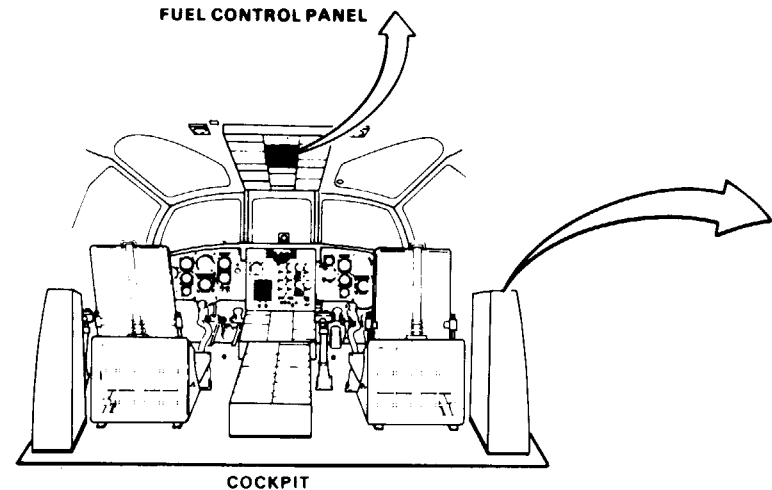
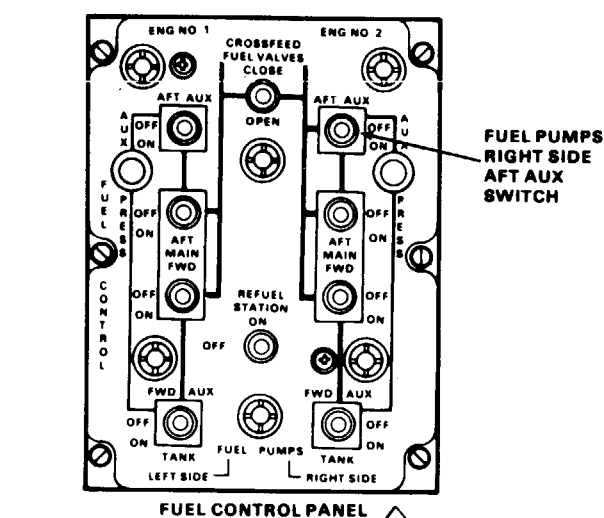

NOTE
CONNECTOR INSTALLATION
IS SIMILAR FOR ALL
TANK ACCESS PANELS

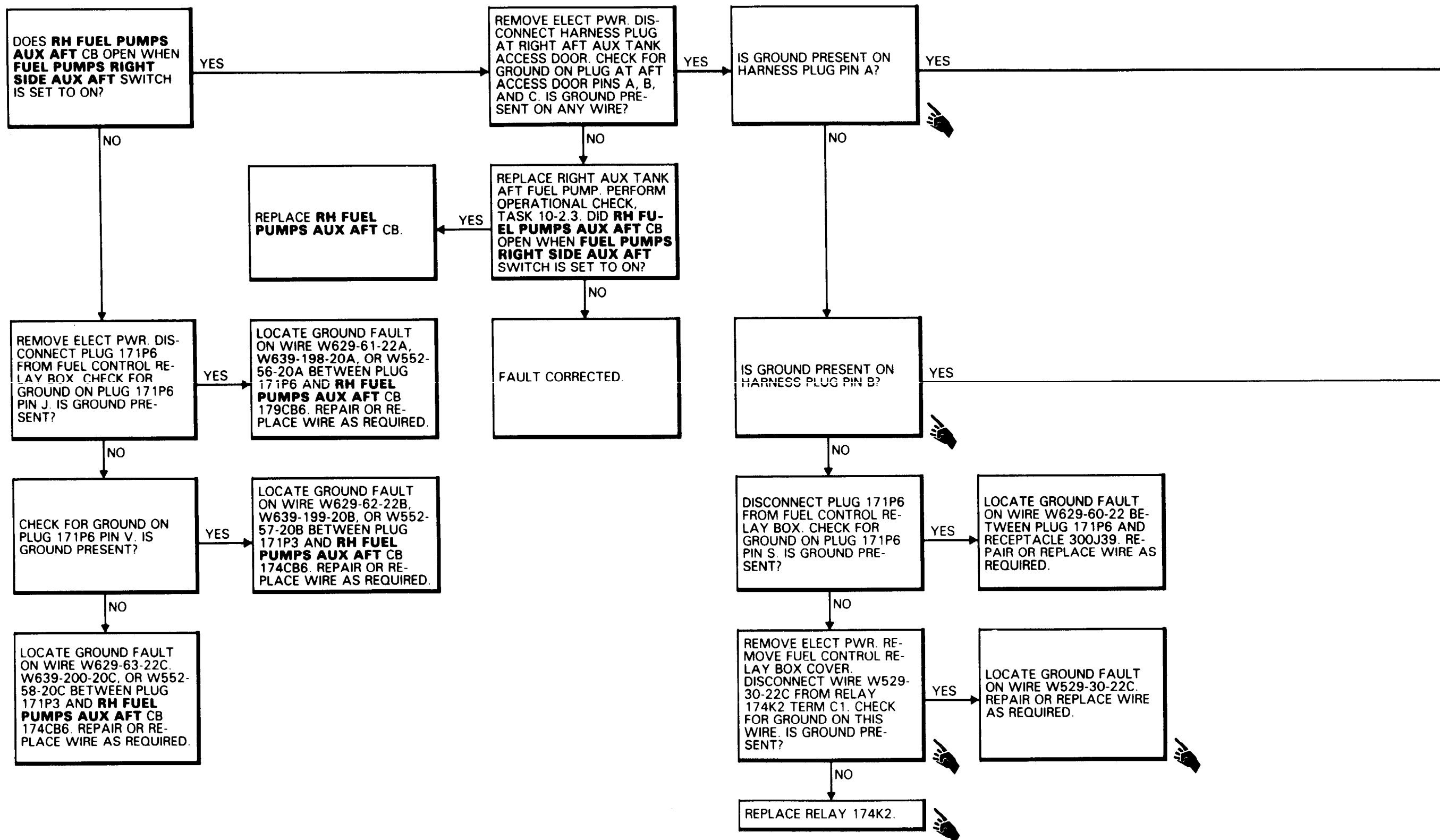

10-2.15 RH FUEL PUMP AUX AFT CIRCUIT BREAKER WILL NOT STAY CLOSED (Continued)

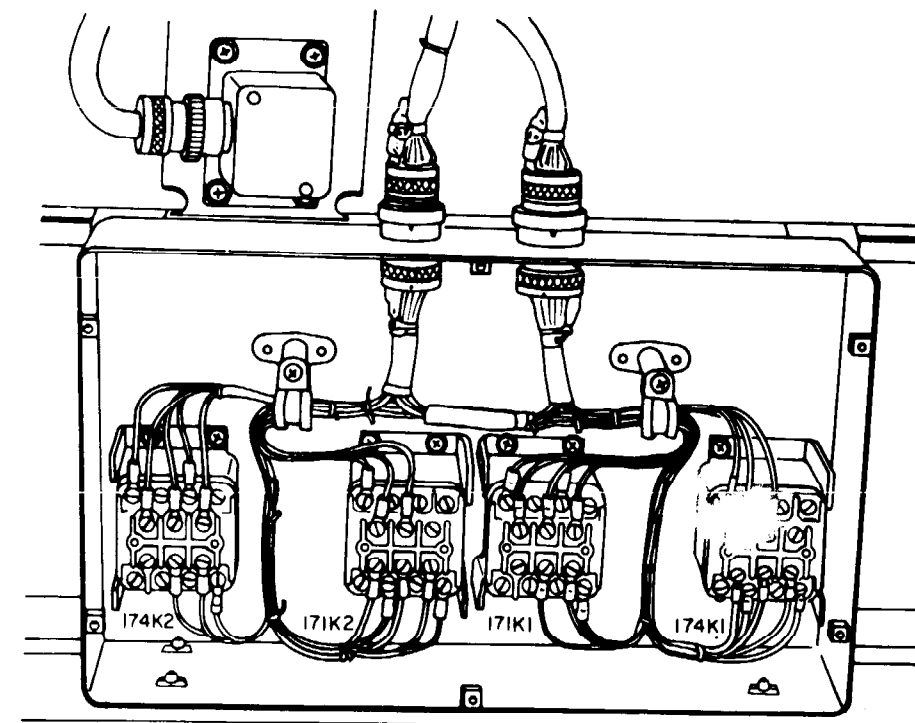
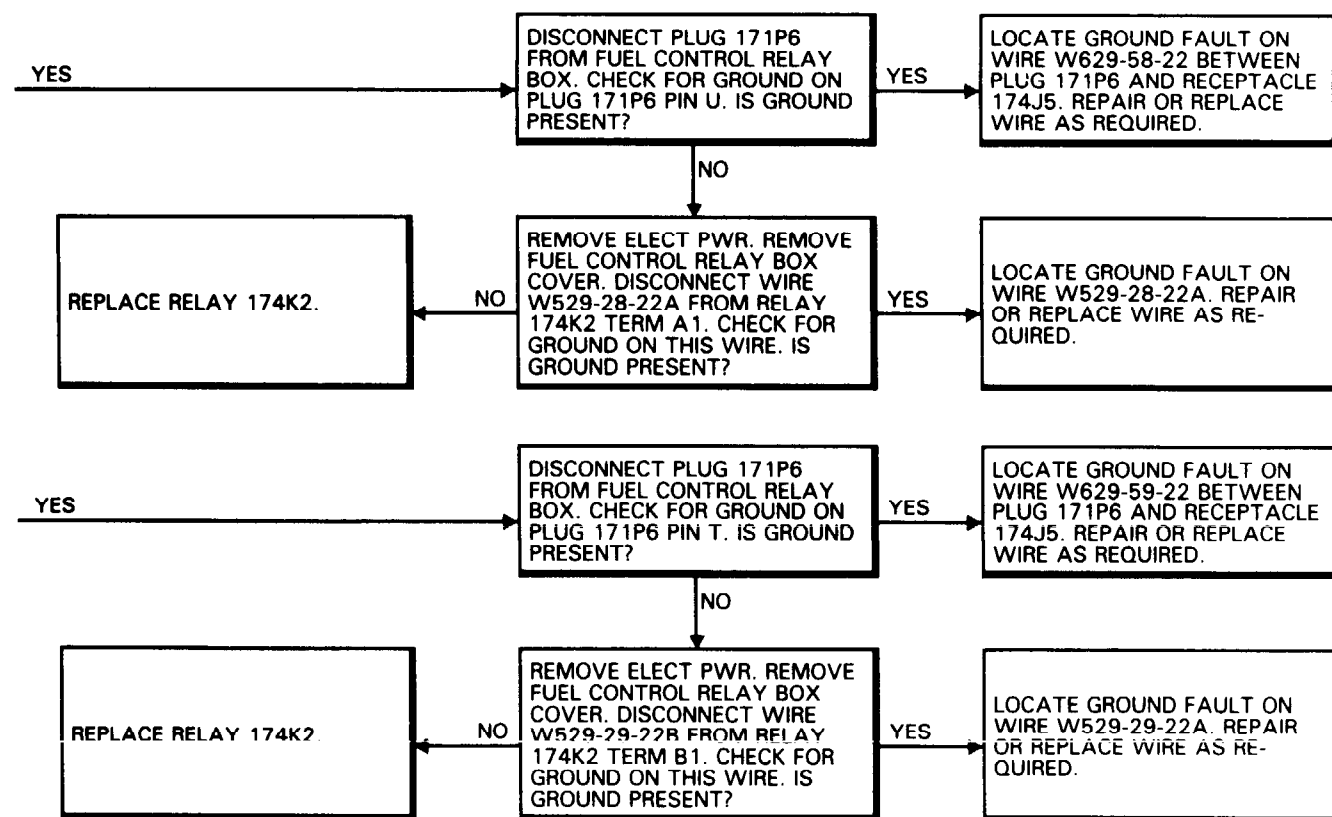

FAULT ISOLATION PROCEDURE

INITIAL SETUP

References:

TM 55-1520-240-23

Applicable Configurations:

All

Tools:

Electrical Repairer's Tool Kit,
NSN 5180-00-323-4915
Multimeter

Equipment Condition:

TM 55-1520-240-23:

Battery Connected
Electrical Power On
Hydraulic Power Off
Side Acoustical Blanket Removed
Between Sta 320 and 360.

Materials:

None

Personnel Required:

68F10 Aircraft Electrician
68F20 Aircraft Electrician

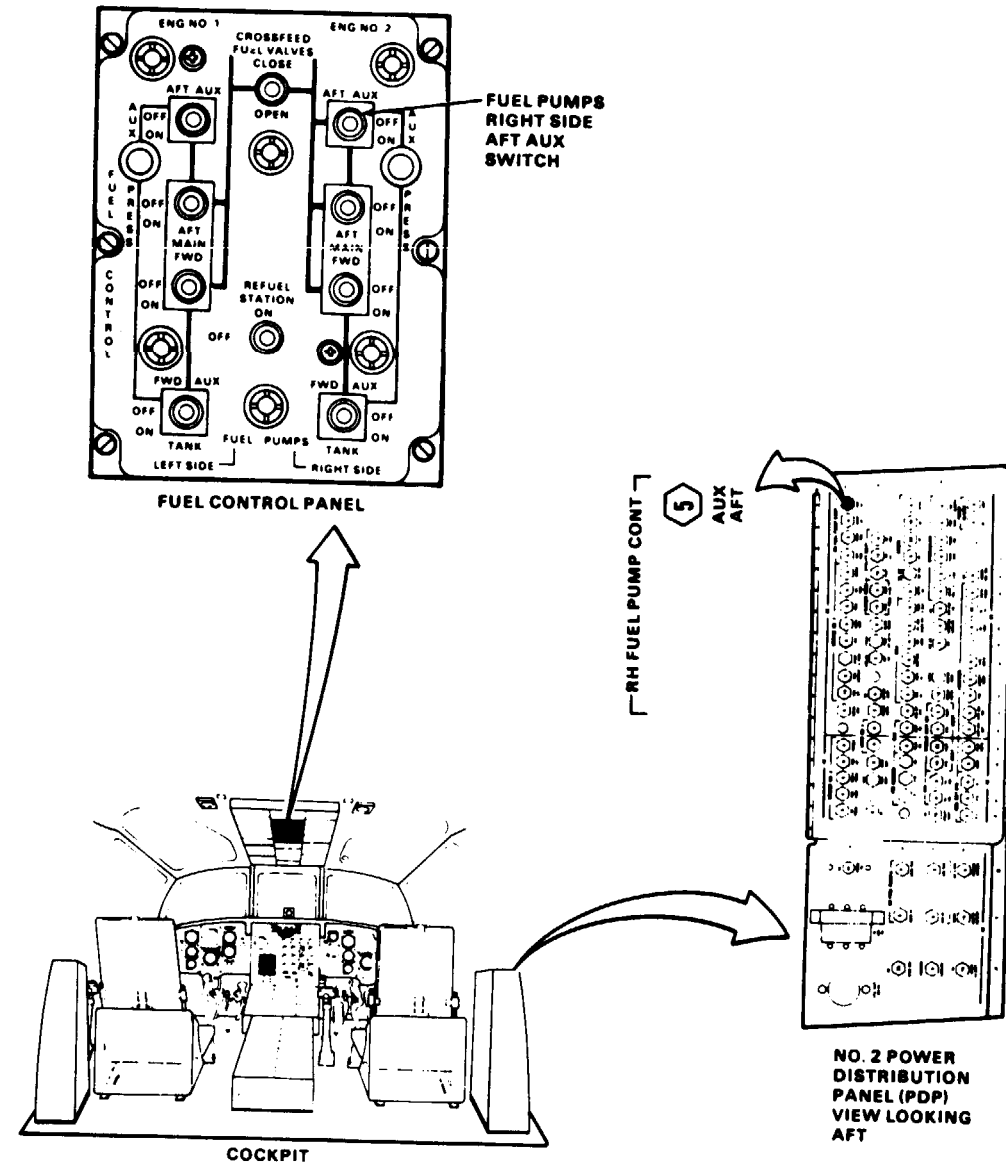
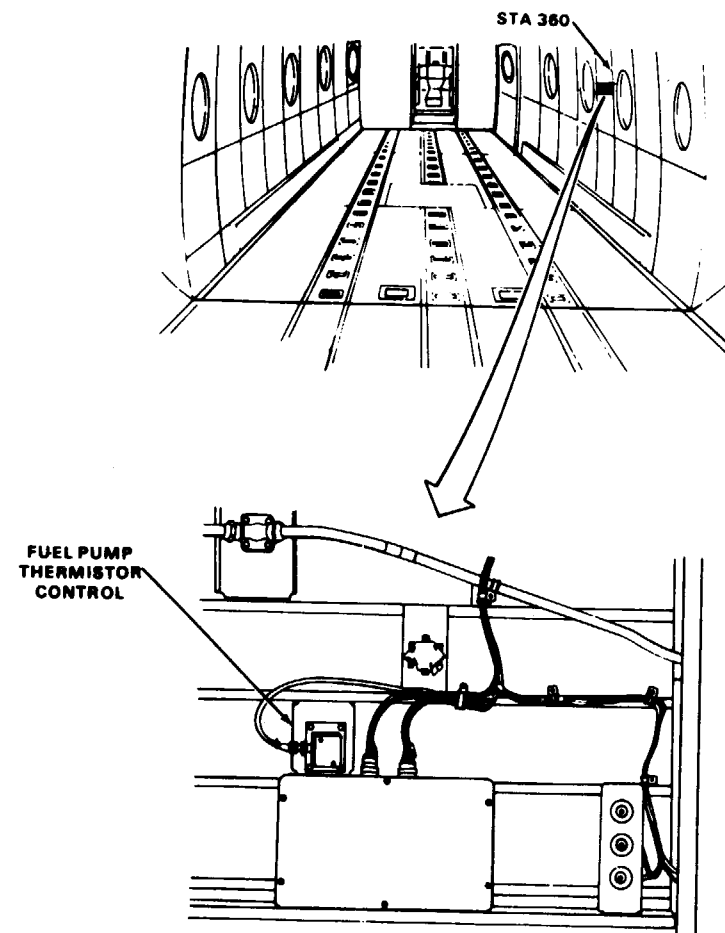

10-2.16 RH FUEL PUMP CONT AUX AFT CIRCUIT BREAKER WILL NOT STAY CLOSED (Continued)

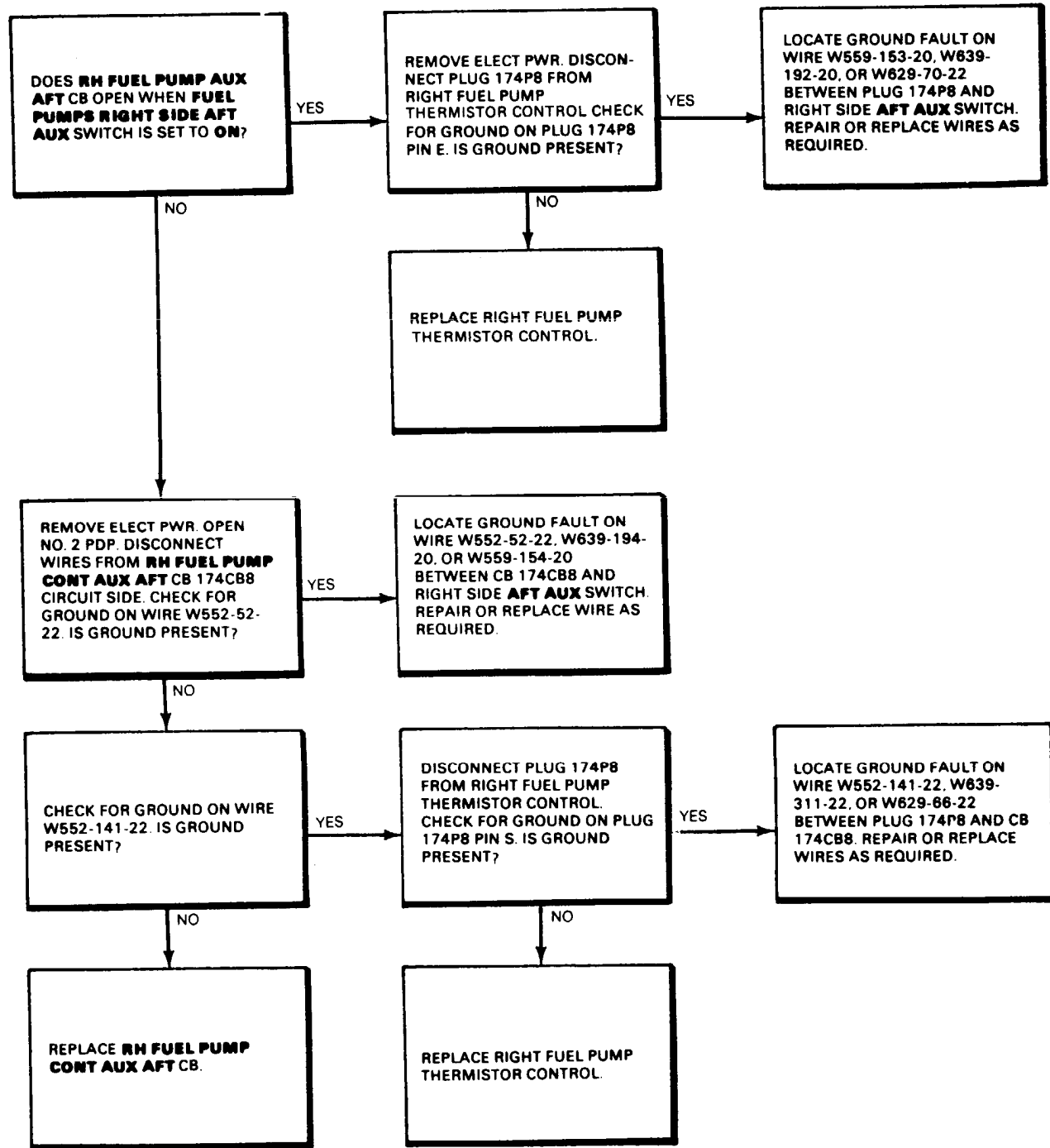

END OF TASK

FAULT ISOLATION PROCEDURE

INITIAL SETUP

Applicable Configurations:

All

Tools:

- Electrical Repairer's Tool Kit,
NSN 5180-00-323-4915
- Multimeter

Materials:

None

Personnel Required:

Aircraft Electrician (2)

References:

TM 55-1520-240-23

Equipment Condition:

- TM 55-1520-240-23:
- Battery Connected
- Electrical Power On
- Hydraulic Power Off
- Side Acoustical Blanket Removed Between Sta 320 and 360

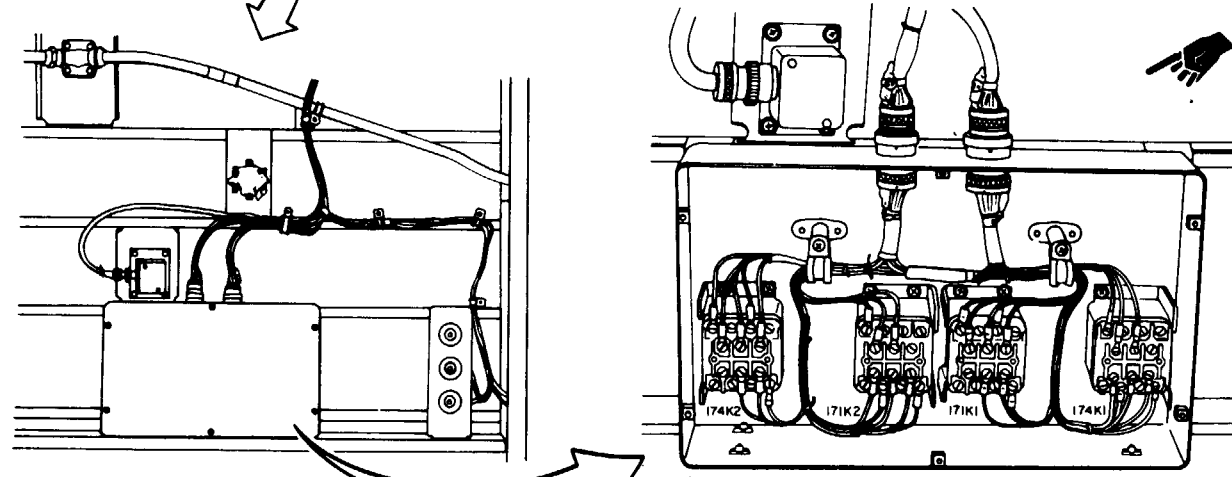
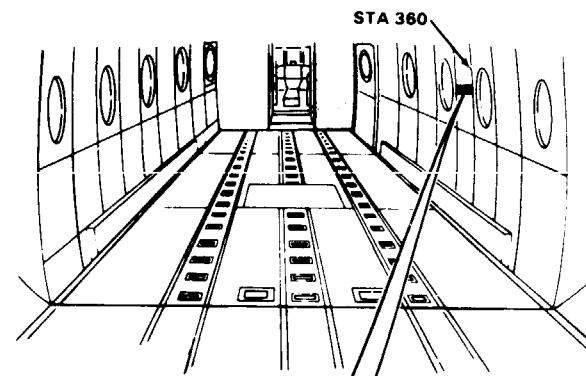

FUEL CONTROL RELAY BOX

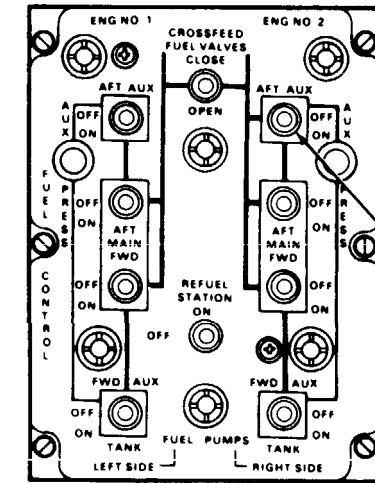

FUEL CONTROL PANEL

FUEL PUMPS RIGHT SIDE AFT MAIN SWITCH

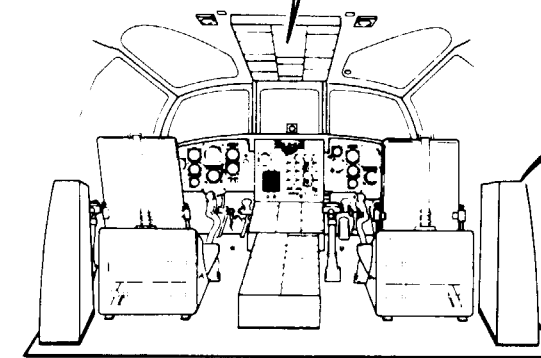

COCKPIT

5
RH FUE JUMP CONT

5
MAIN AFT

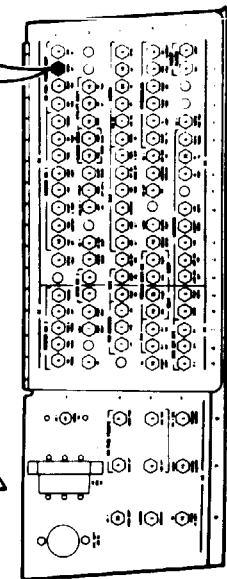

NO. 2 POWER DISTRIBUTION PANEL (PDP) VIEW LOOKING AFT

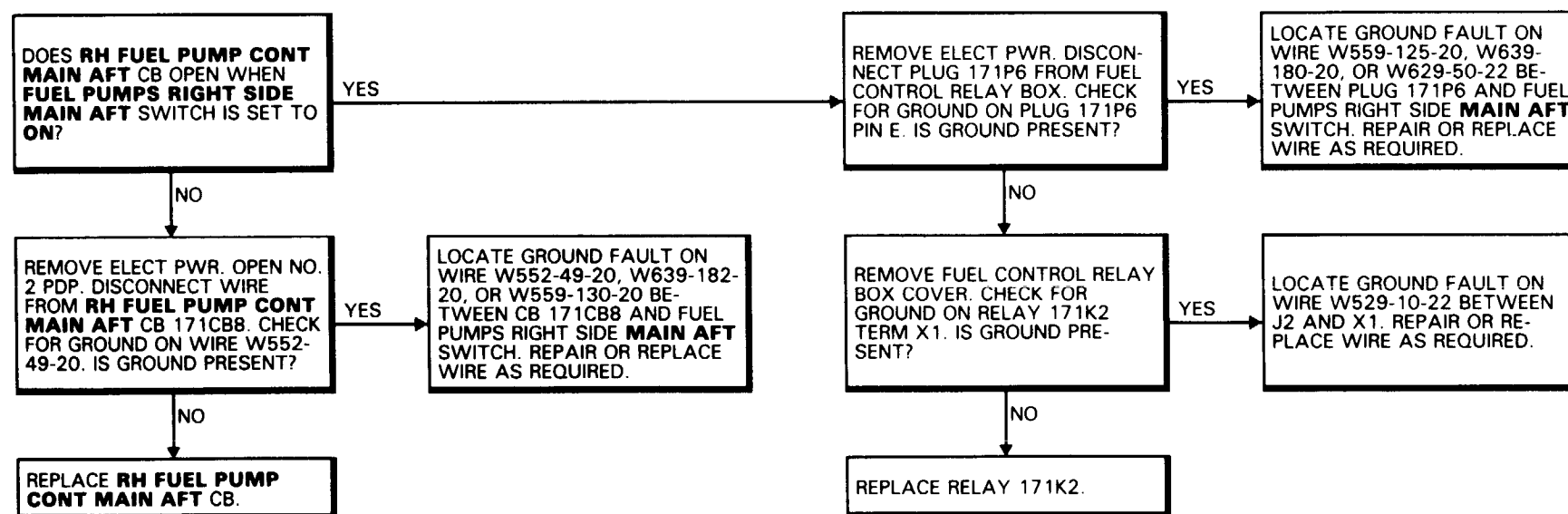

FAULT ISOLATION PROCEDURE

INITIAL SETUP

Applicable Configurations:

All

Tools:

- Electrical Repairer's Tool Kit,
NSN 5180-00-323-4915
- Multimeter

Materials:

None

Personnel Required:

- Aircraft Electrician (2)

References:

TM 55-1520-240-23

Equipment Condition:

- TM 55-1520-240-23:
- Battery Connected
- Electrical Power On
- Hydraulic Power Off
- Side Acoustical Blanket Removed Between Sta 320 and 360

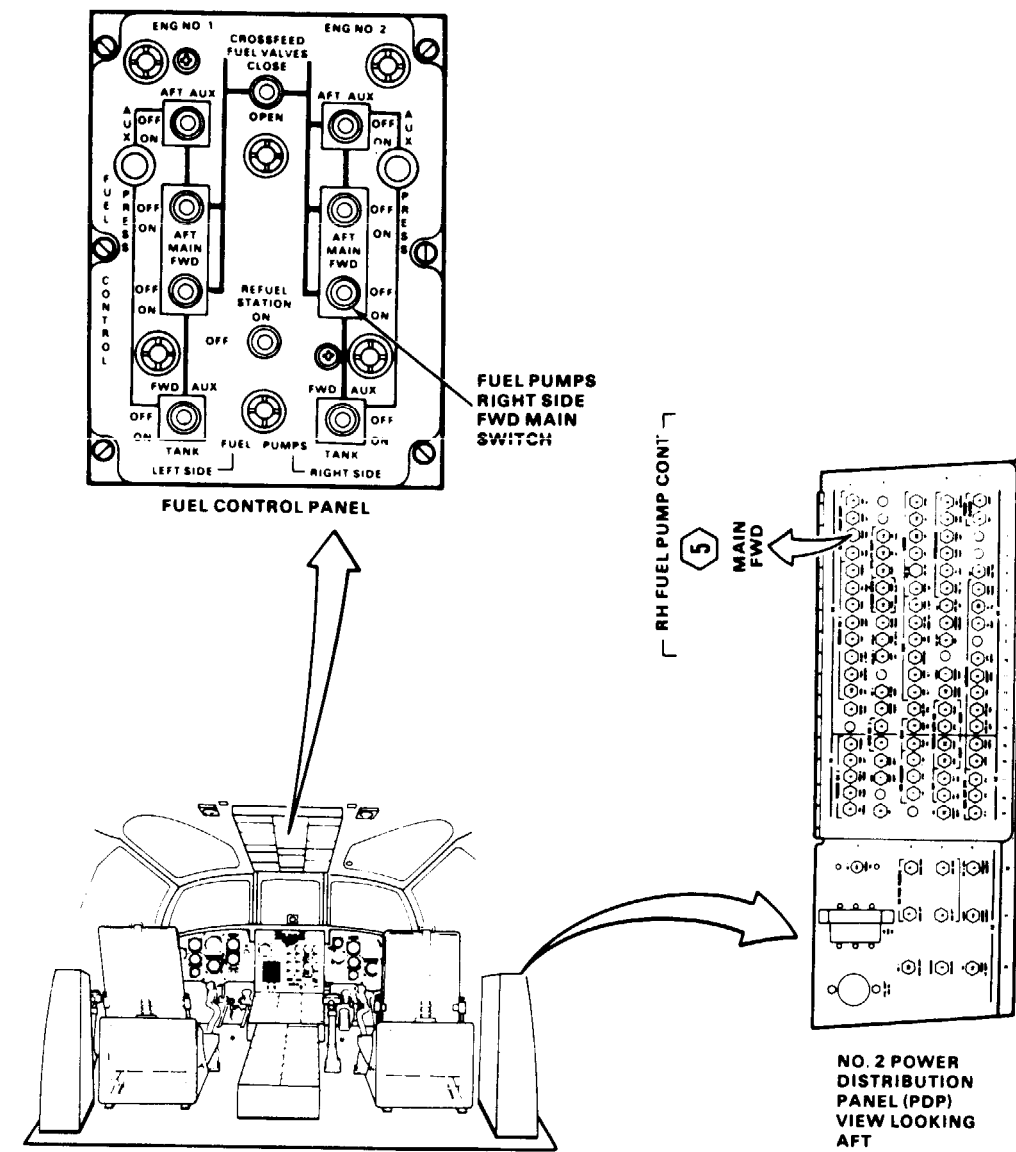
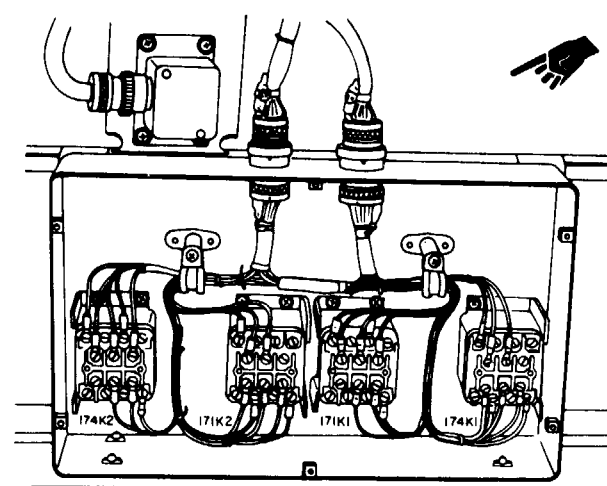
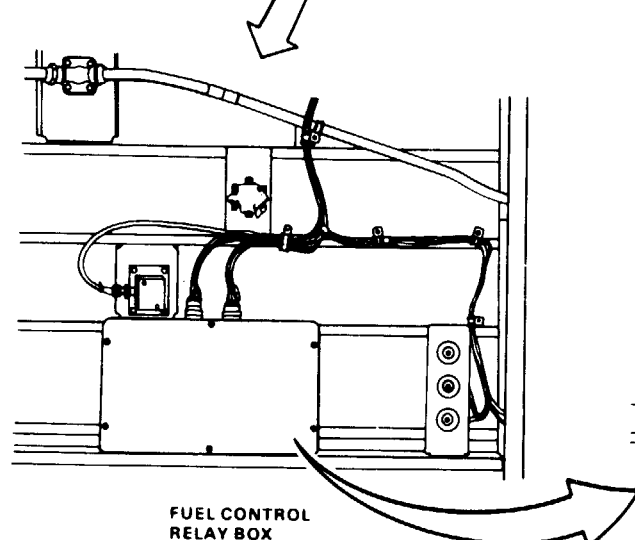
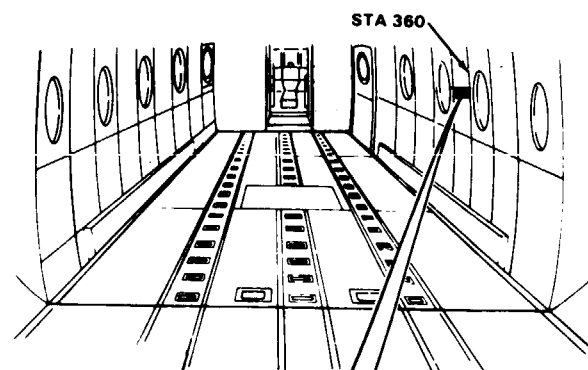

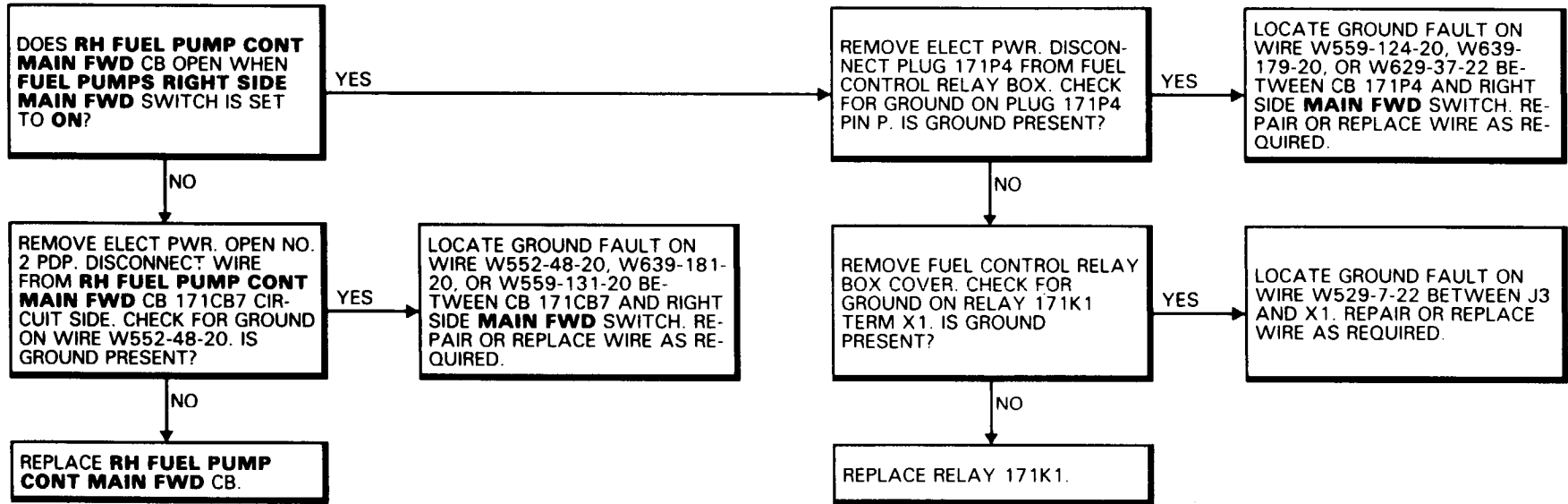

10-2.19 RH FUEL PUMP CONT AUX FWD CIRCUIT
BREAKER WILL NOT STAY CLOSED

FAULT ISOLATION PROCEDURE

INITIAL SETUP

References:

TM 55-1520-240-23

Applicable Configurations:

All

Equipment Condition:

TM 55-1520-240-23:

- Battery Connected
- Electrical Power On
- Hydraulic Power Off
- Side Acoustical Blanket Removed Between Sta 320 and 360

Tools:

- Electrical Repairer's Tool Kit,
NSN 5180-00-323-4915
- Multimeter

Materials:

None

Personnel Required:

Aircraft Electrician (2)

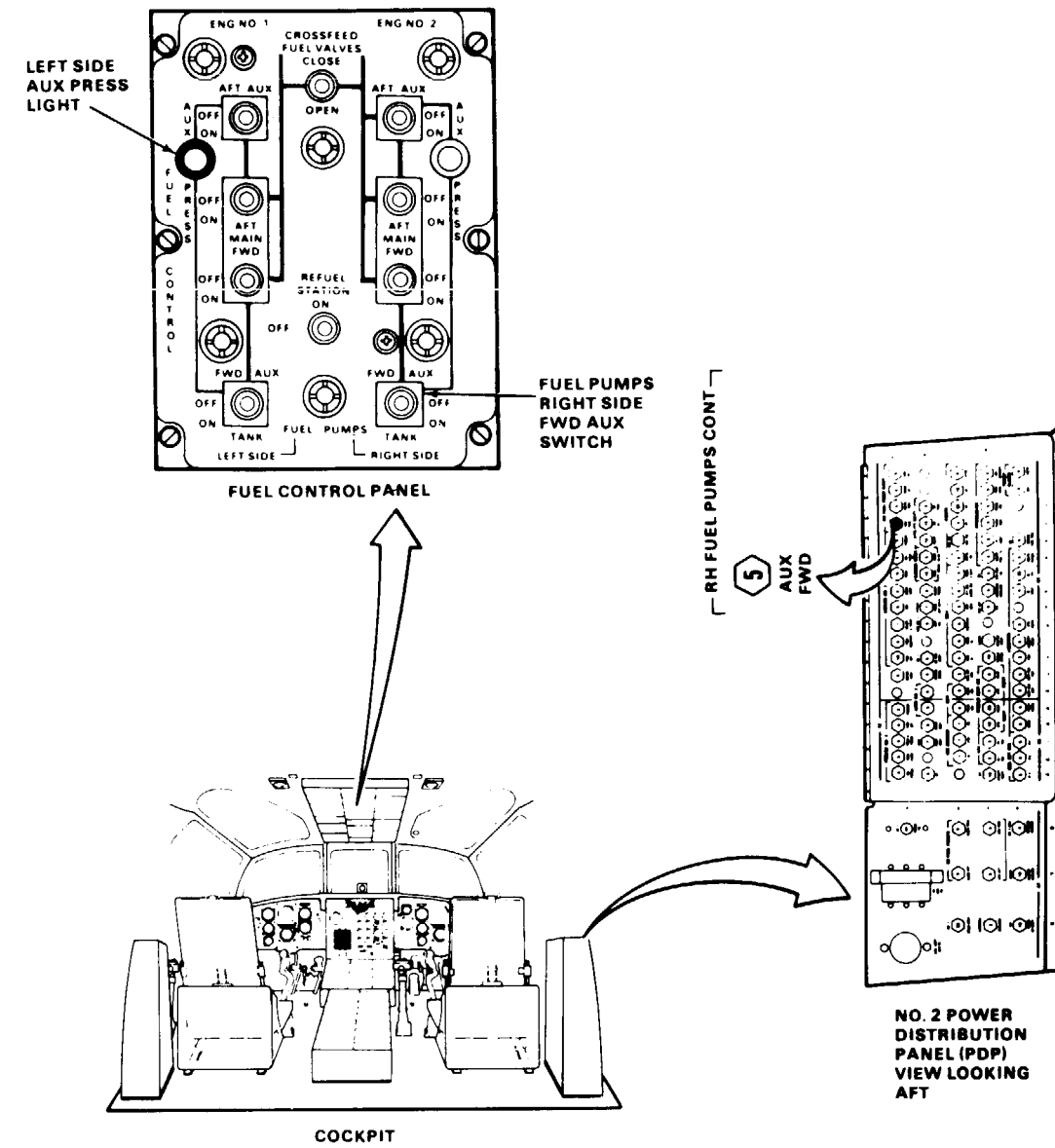
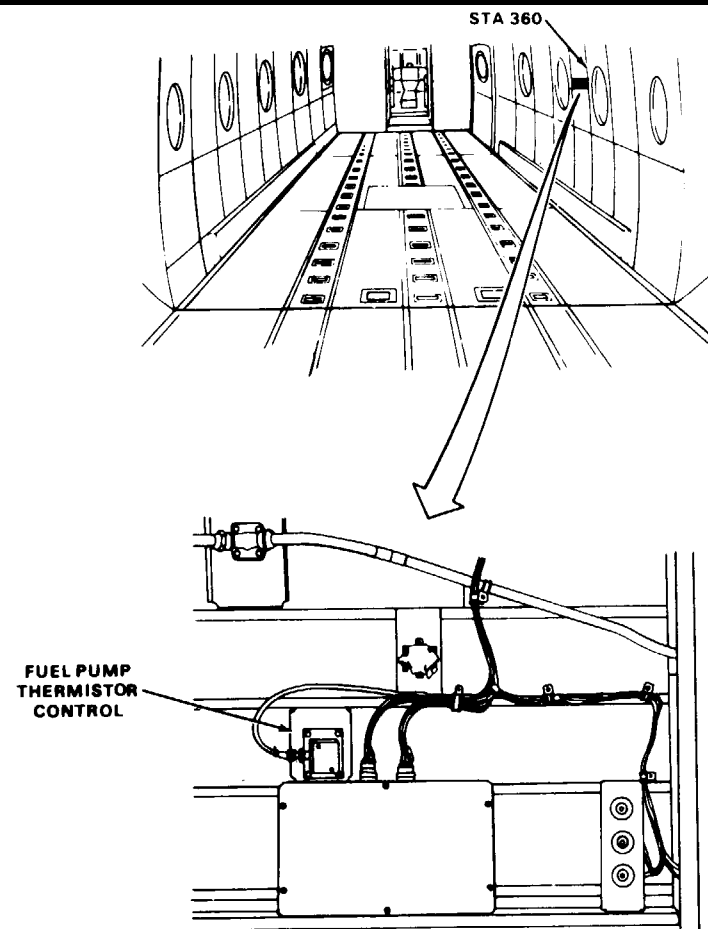

10-2.19 RH FUEL PUMP CONT AUX FWD CIRCUIT BREAKER WILL NOT STAY CLOSED (Continued)

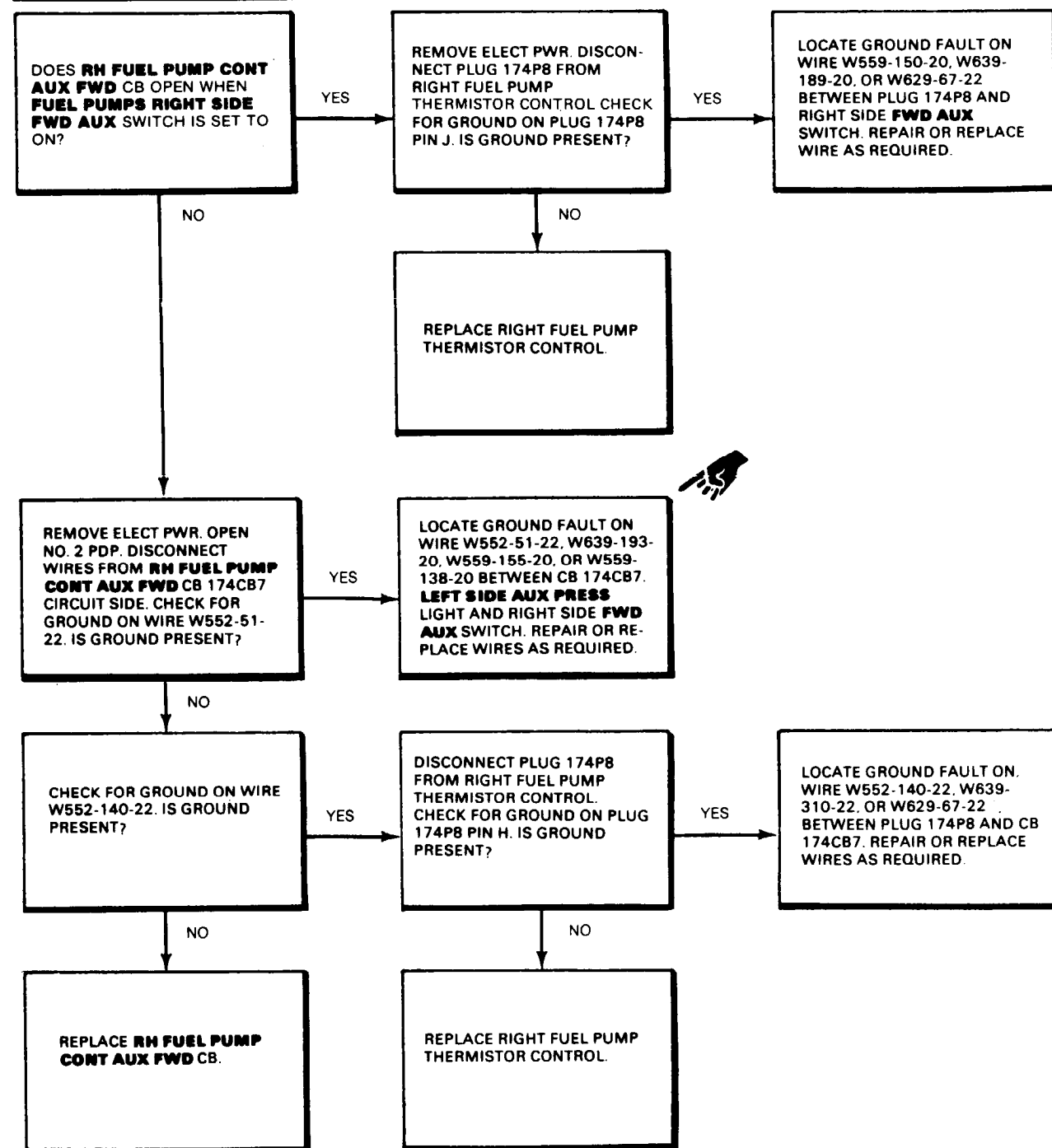

END OF TASK

10-2.20 LEFT OR RIGHT SIDE AUX PRESS LIGHTS
DOES NOT COME ON WHEN PRESSED TO TEST

FAULT ISOLATION PROCEDURE

INITIAL SETUP

Personnel Required:
68F20 Aircraft Electrician

Applicable Configurations:
All

References:
TM 55-1520-240-23

Tools:
Electrical Repairer's Tool Kit,
NSN 5180-00-323-4915
Multimeter

Equipment Condition:
TM 55-1520-240-23
Battery Connected
Electrical Power On
Hydraulic Power Off

Materials:
None

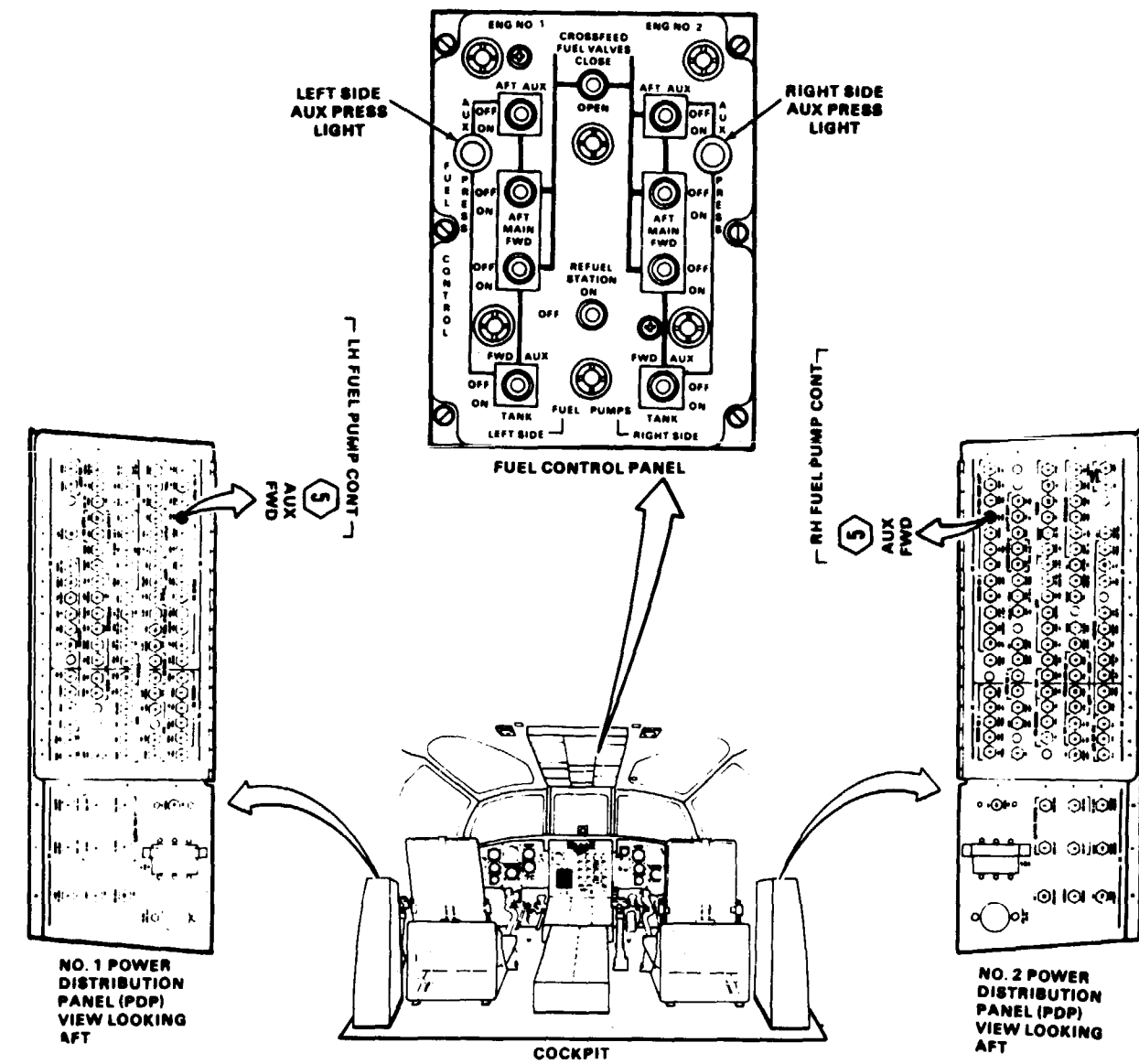

48X84

D145-11747-8PA

10-2.20 LEFT OR RIGHT SIDE AUX PRESS LIGHTS DOES NOT COME ON WHEN PRESSED TO TEST (Continued)

LEFT SIDE AUX PRESS LIGHT DOES NOT COME ON WHEN PRESSED TO TEST

RIGHT SIDE AUX PRESS LIGHT DOES NOT COME ON WHEN PRESSED TO TEST

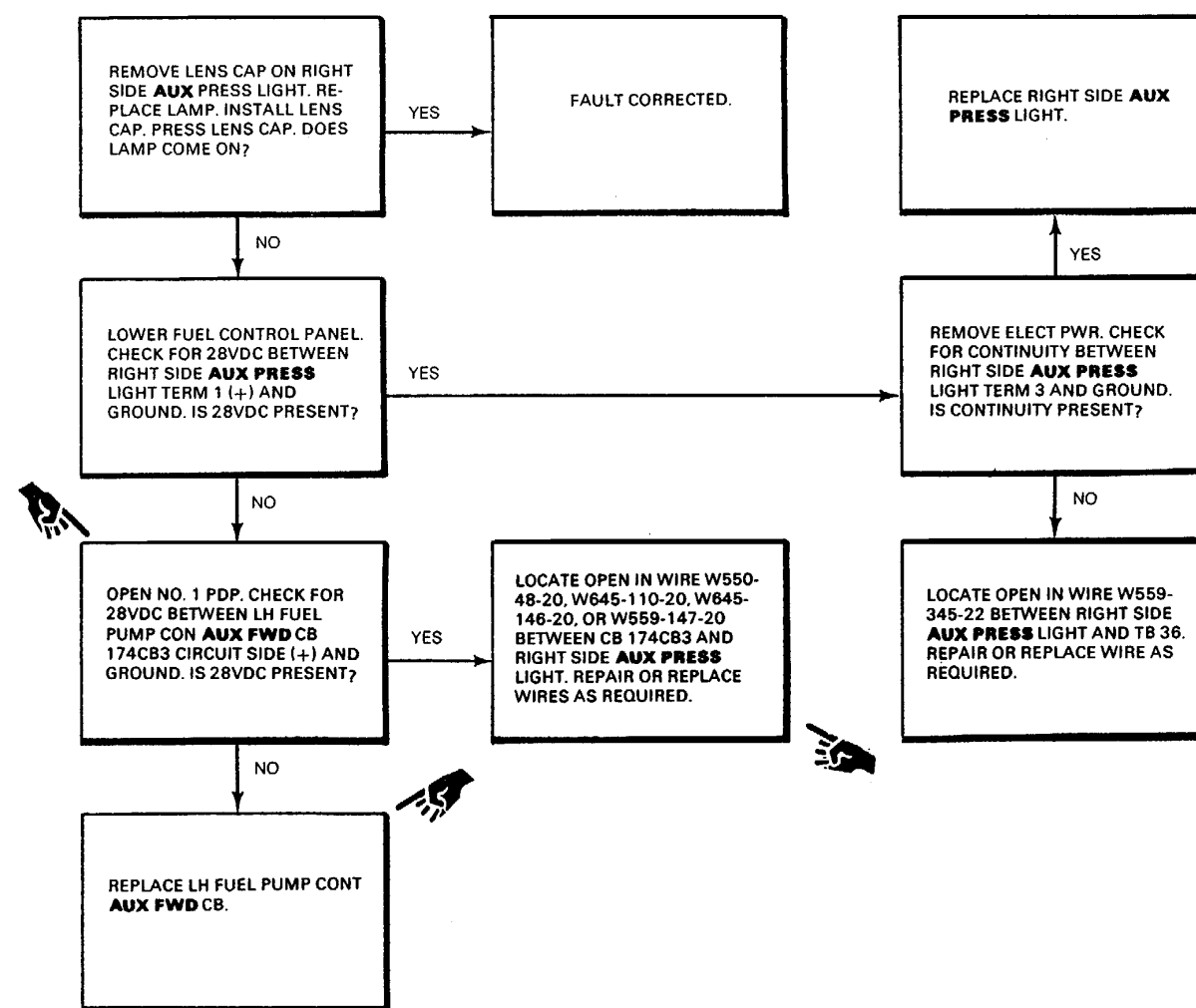
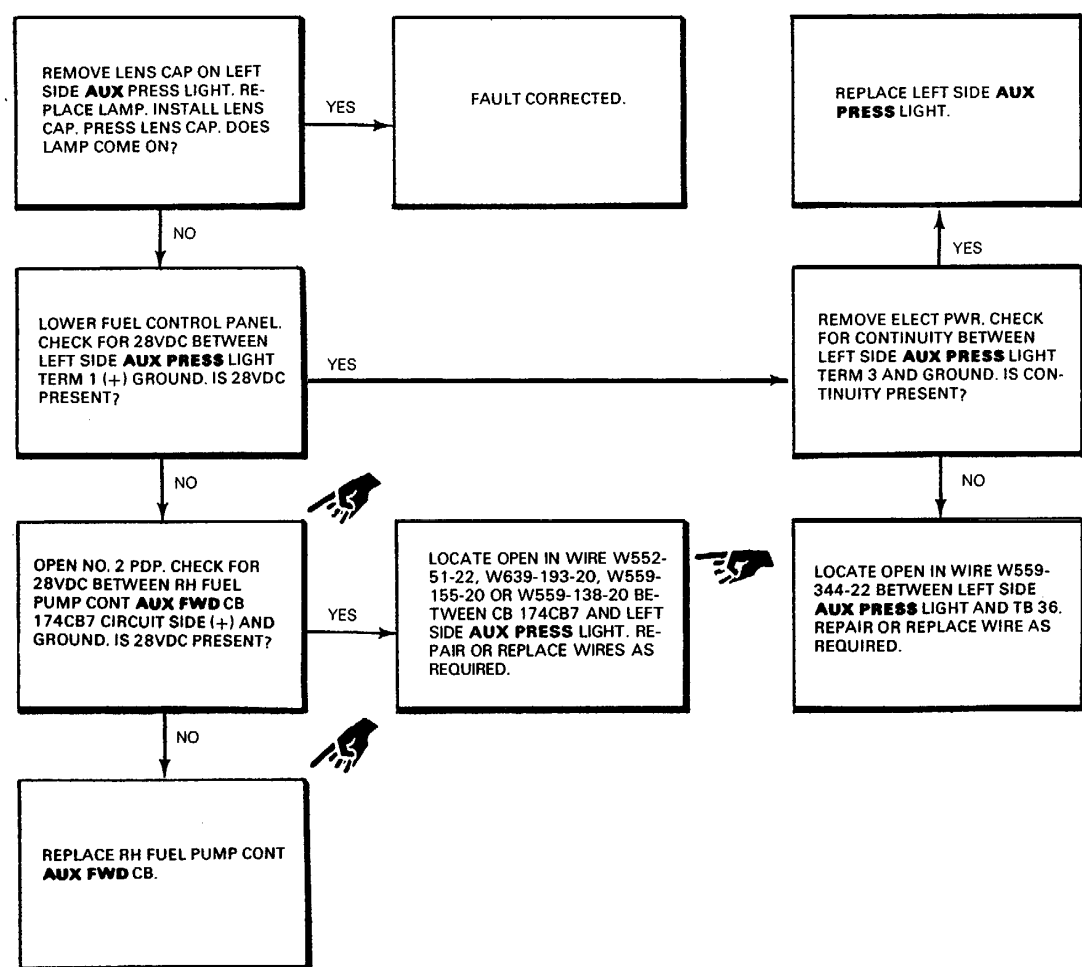

END OF TASK

Change 2 10-79

FAULT ISOLATION PROCEDURE

INITIAL SETUP

Applicable Configurations:

All

Tools

Electrical Repairer's Tool Kit,
NSN 5180-00-323-4915

Multimeter

Materials

None

Personnel Required:

Aircraft Electrician (2)

References

TM 55-1520-240-23

Equipment Condition:

TM 55-1520-240-23:

Battery Connected

Electrical Power On

Hydraulic Power Off

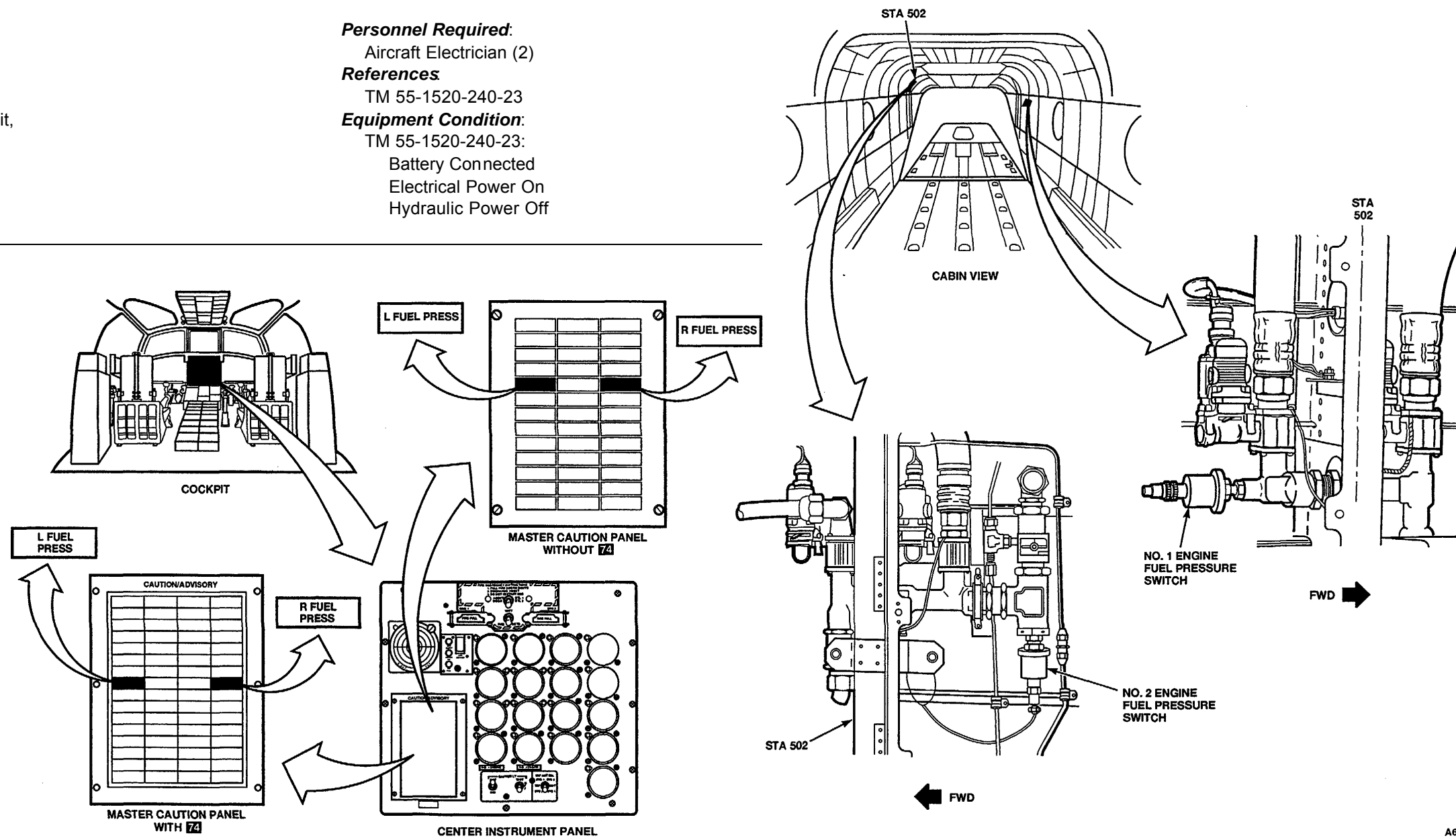

A65447

L FUEL PRESS CAPSULE IS NOT ON

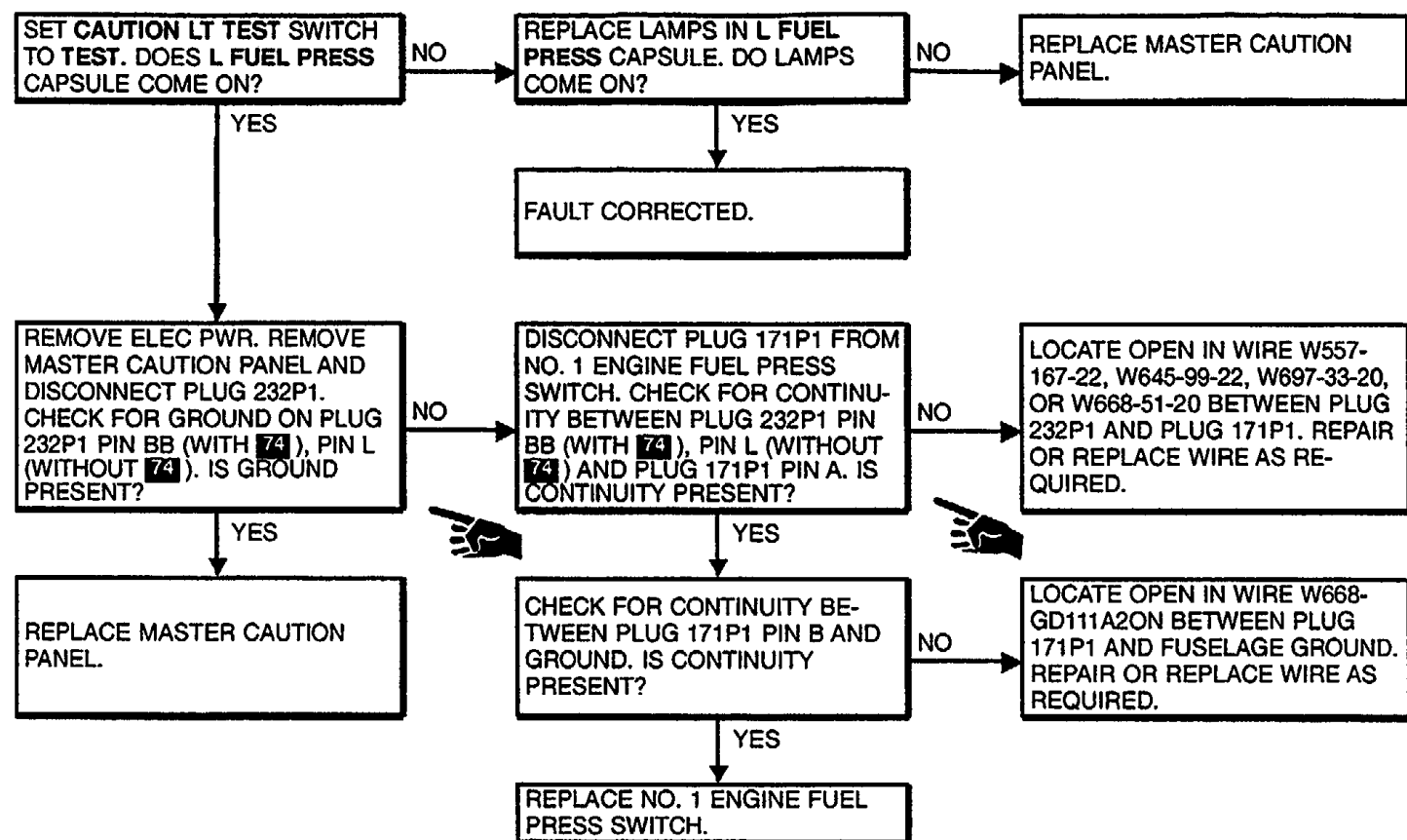

R FUEL PRESS CAPSULE IS NOT ON

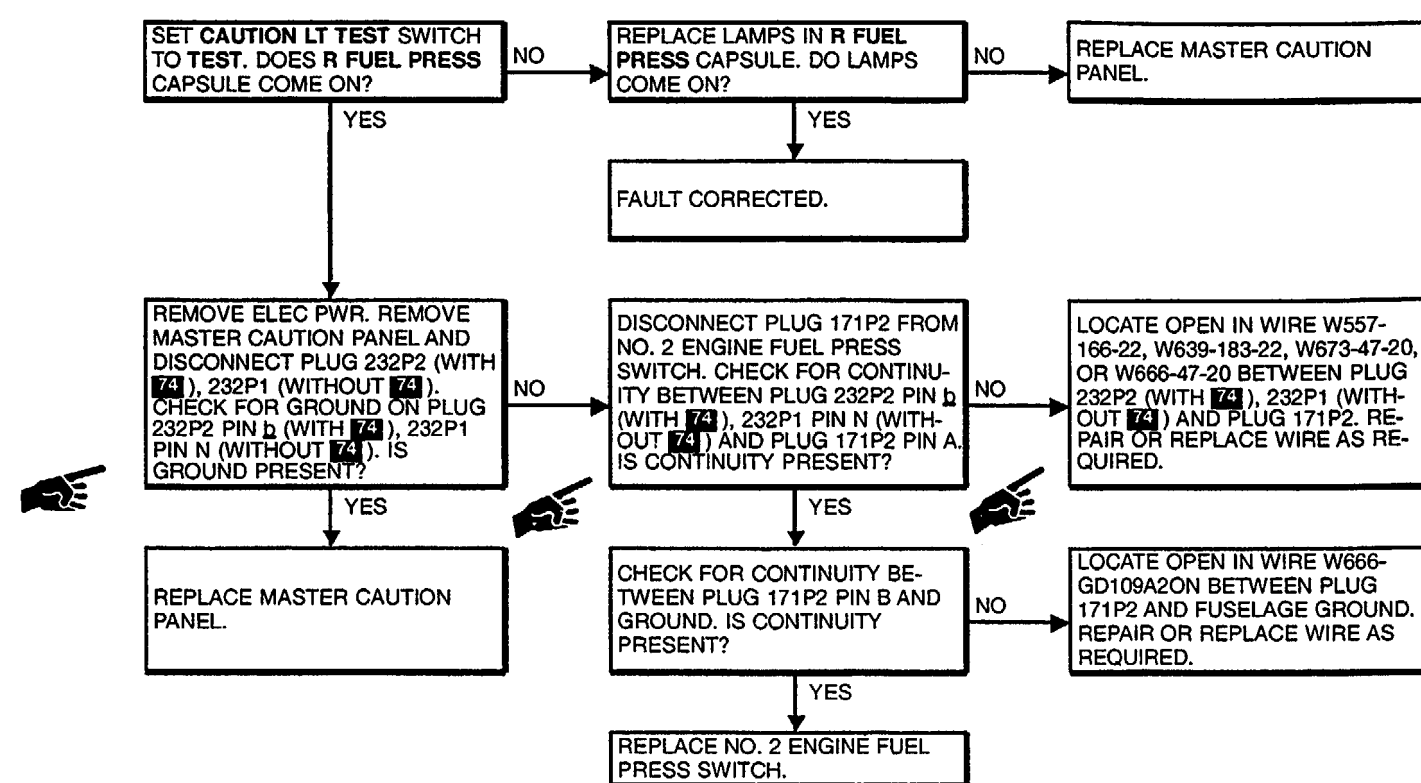

10-2.22 L FUEL PRESS CAPSULE DOES NOT GO OUT WHEN LEFT SIDE MAIN AFT FUEL PUMPS SWITCH IS SET TO ON

FAULT ISOLATION PROCEDURE

INITIAL SETUP

Applicable Configurations:

All

Tools:

- Electrical Repairer's Tool Kit,
NSN 5180-00-323-4915
- Multimeter

Materials:

None

Personnel Required:

Aircraft Electrician (2)

References:

- TM 55-1520-240-10
- TM 55-1520-240-23

Equipment Condition:

- TM 55-1520-240-10:
Both Engines Shut Down
- TM 55-1520-1520-240-23:
Battery Connected
Electrical Power On
Hydraulic Power Off
Side Acoustical Blanket Removed Between Sta 320
and 360
Left Aft Intertank Access Panel Open

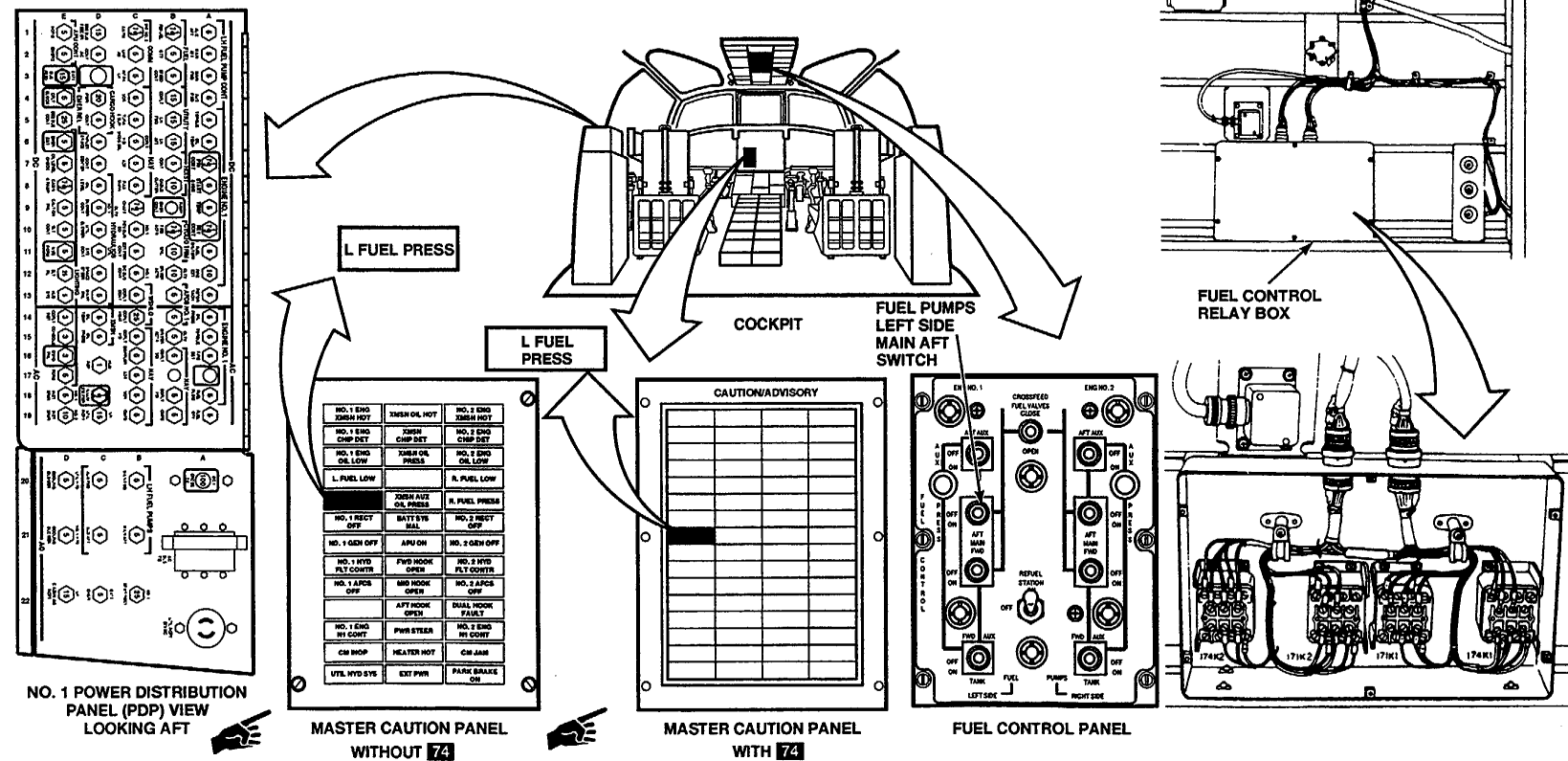
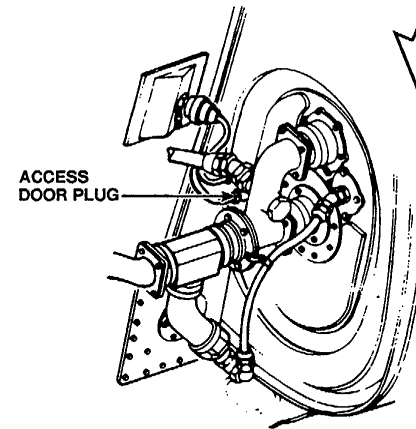
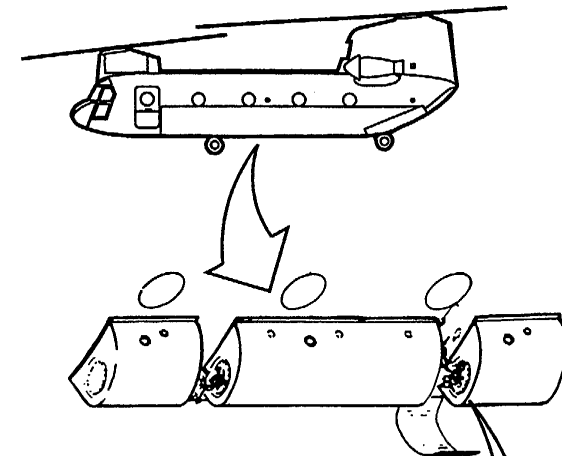
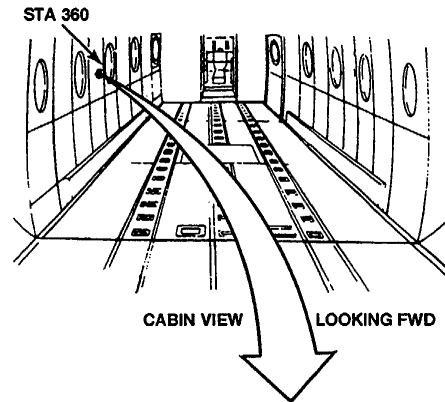

NOTE:
CONNECTOR INSTALLATION
IS SIMILAR FOR ALL TANK
ACCESS PANELS.

A65448

10-2.22 L FUEL PRESS CAPSULE DOES NOT GO OUT WHEN LEFT SIDE MAIN AFT FUEL PUMPS SWITCH IS SET TO ON (Continued)

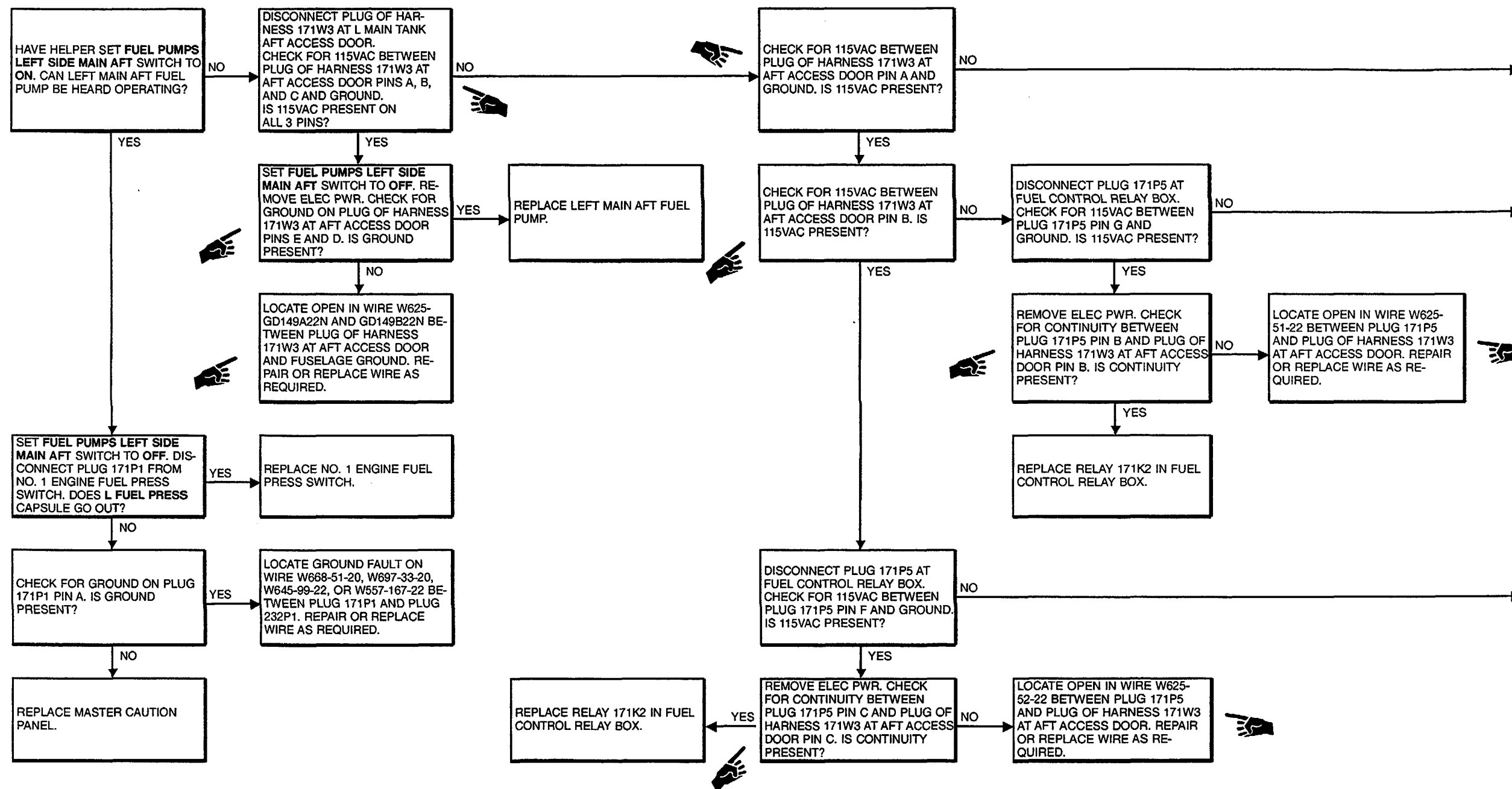

10-2.22 L FUEL PRESS CAPSULE DOES NOT GO OUT WHEN LEFT SIDE MAIN AFT FUEL PUMPS SWITCH IS SET TO ON (Continued)

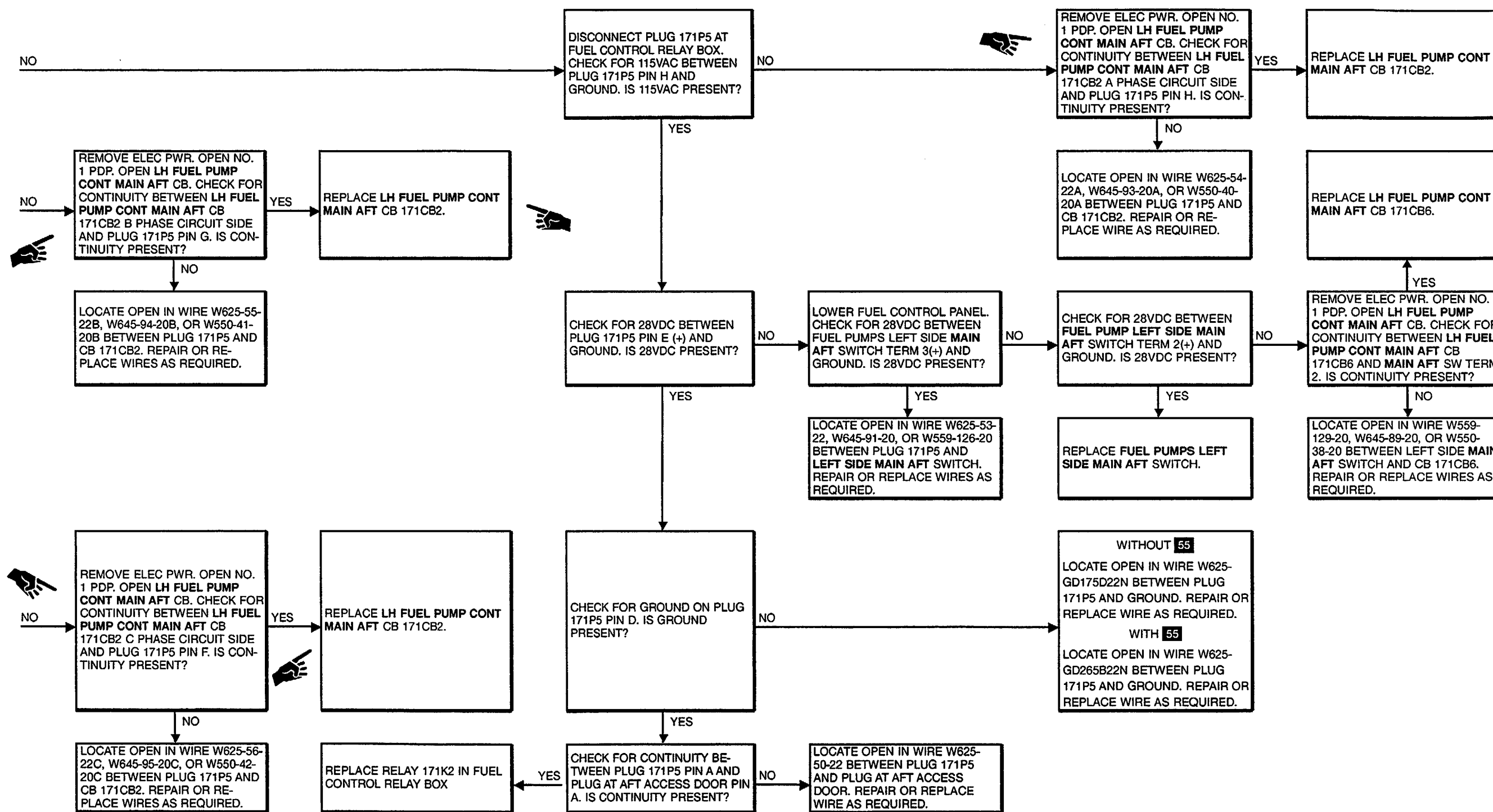

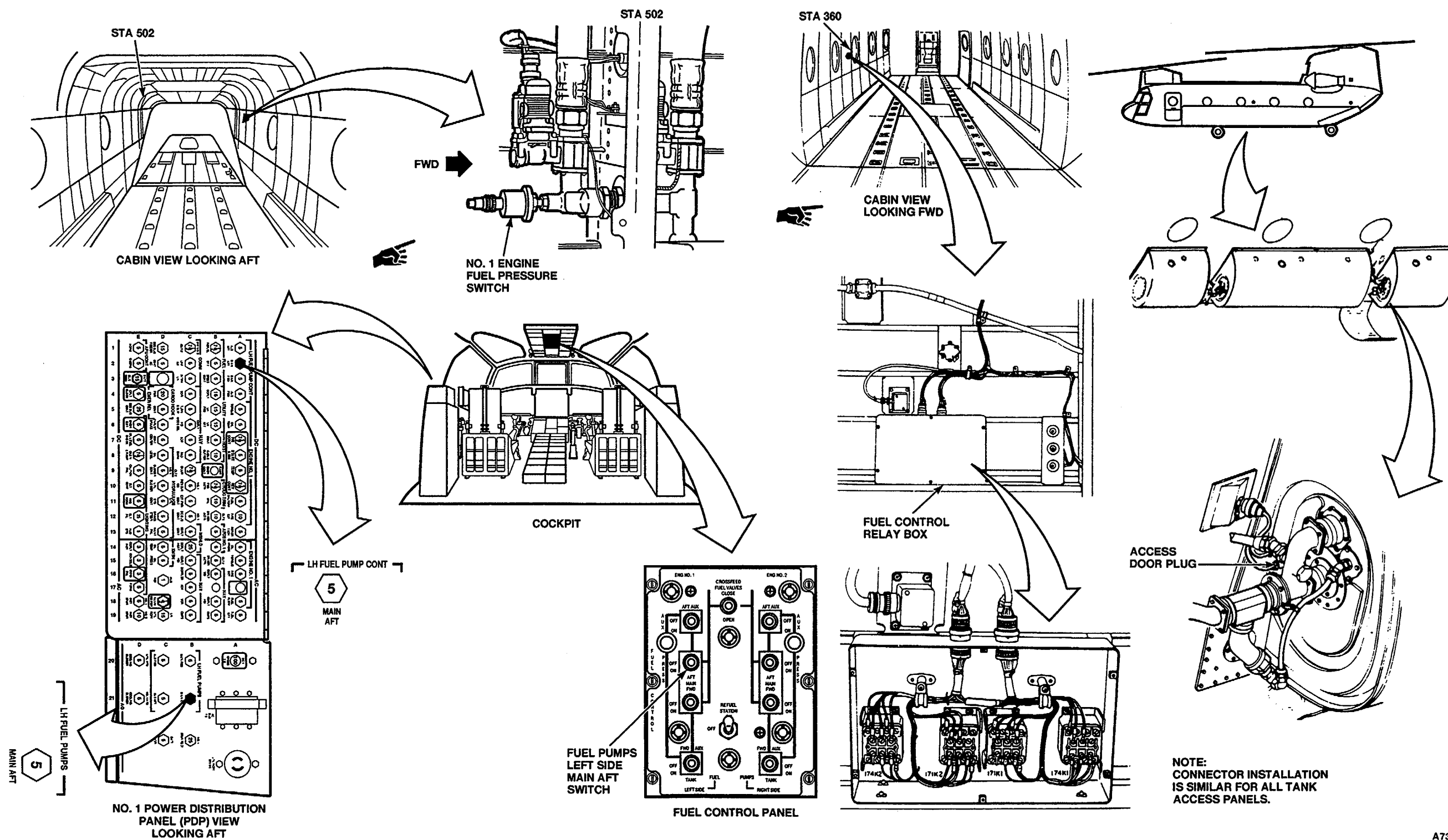

A73597

10-2.23 L FUEL PRESS CAPSULE DOES NOT GO OUT WHEN LEFT SIDE MAIN FWD FUEL PUMPS SWITCH IS SET TO ON

FAULT ISOLATION PROCEDURE

INITIAL SETUP

Applicable Configurations:

All

Tools:

Electrical Repairer's Tool Kit,
NSN 5180-00-323-4915

Multimeter

Materials:

None

Personnel Required:

Aircraft Electrician (2)

References:

TM 55-1520-240-10

TM 55-1520-240-23

Equipment Condition:

TM 55-1520-240-10:

Both Engines Shut Down

TM 55-1520-240-23:

Battery Connected

Electrical Power On

Hydraulic Power Off

Side Acoustical Blanket Removed Between Sta 320
and 360

Left Fwd Landing Gear Access Panel Open

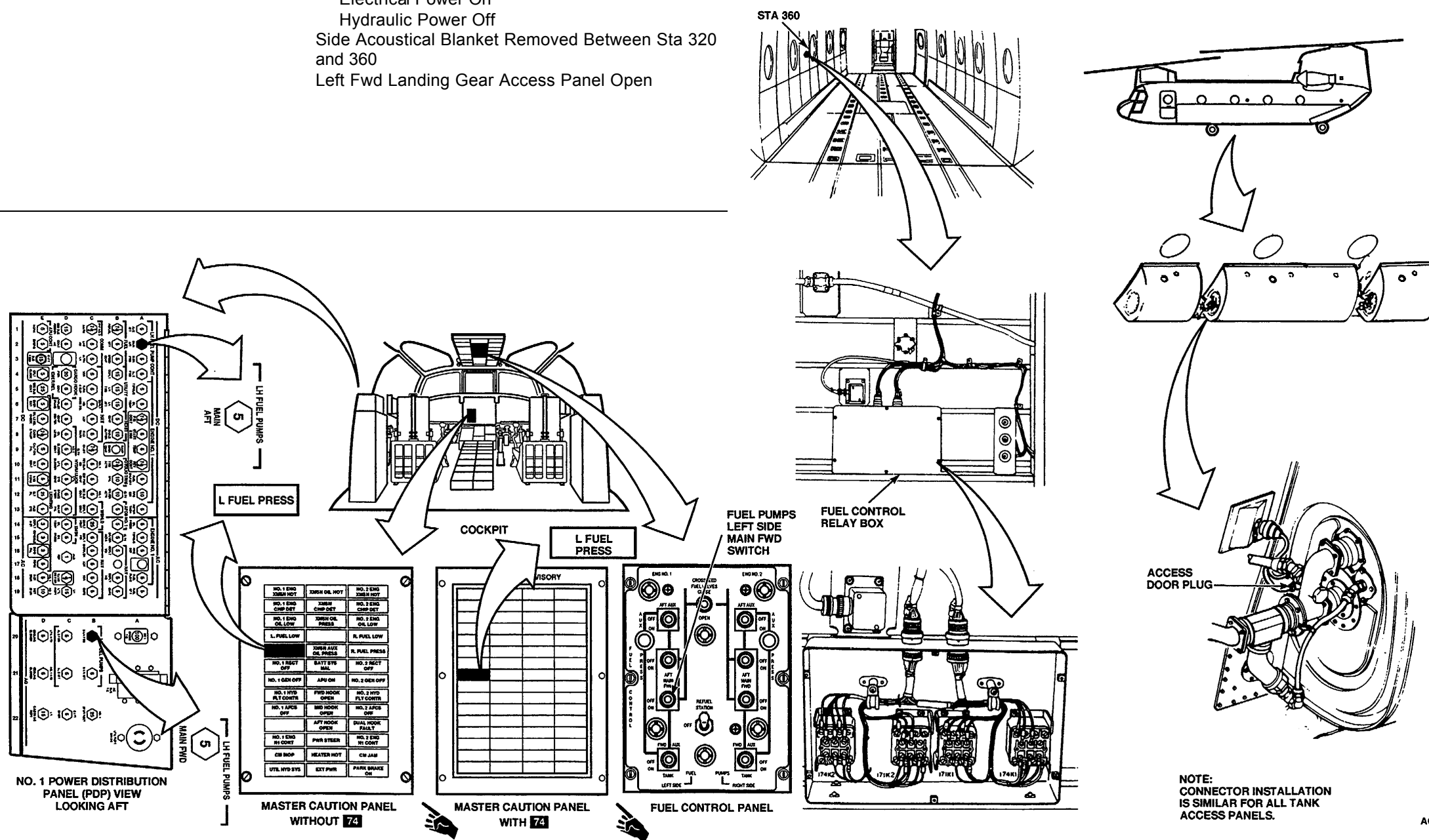

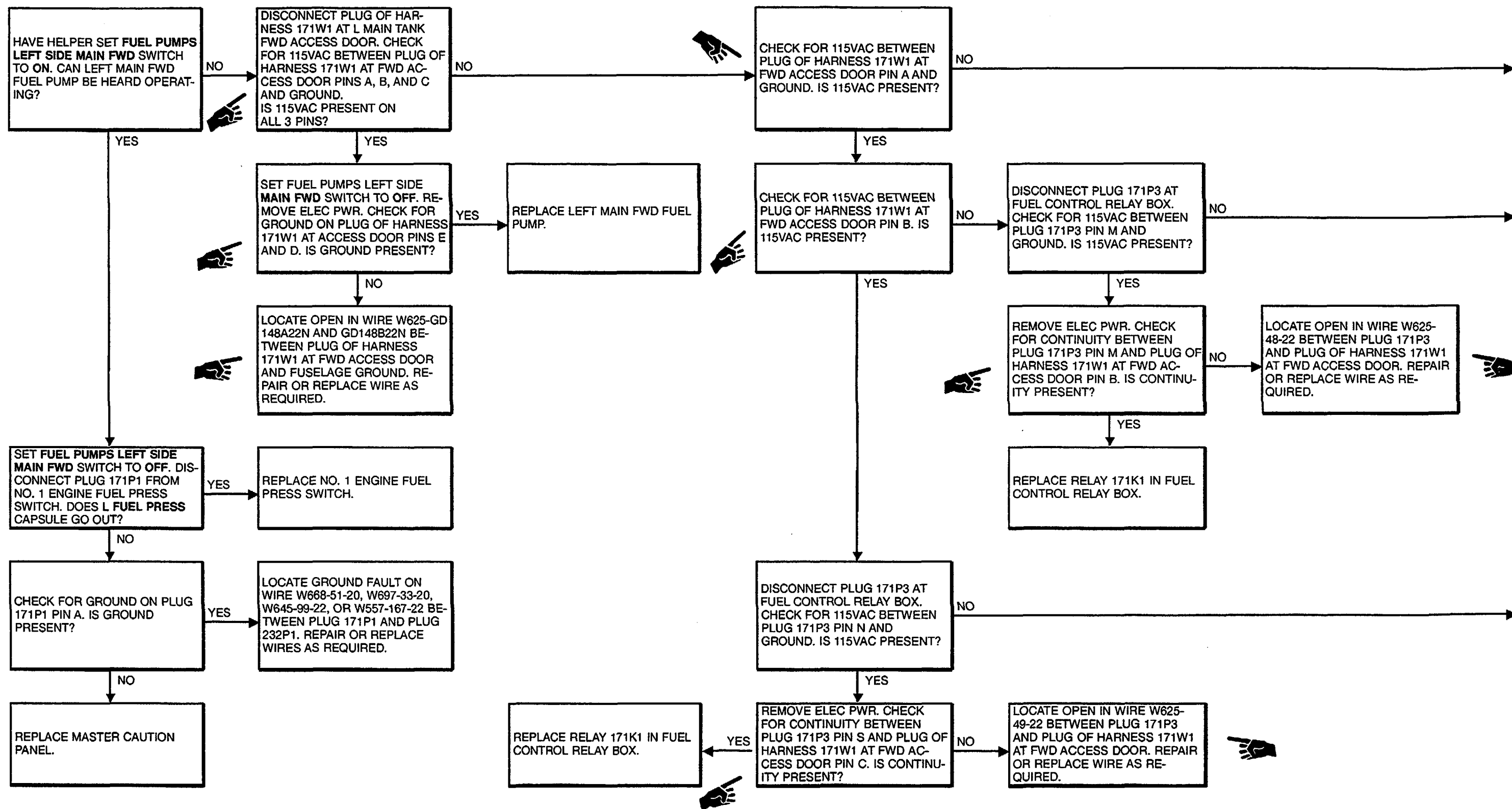

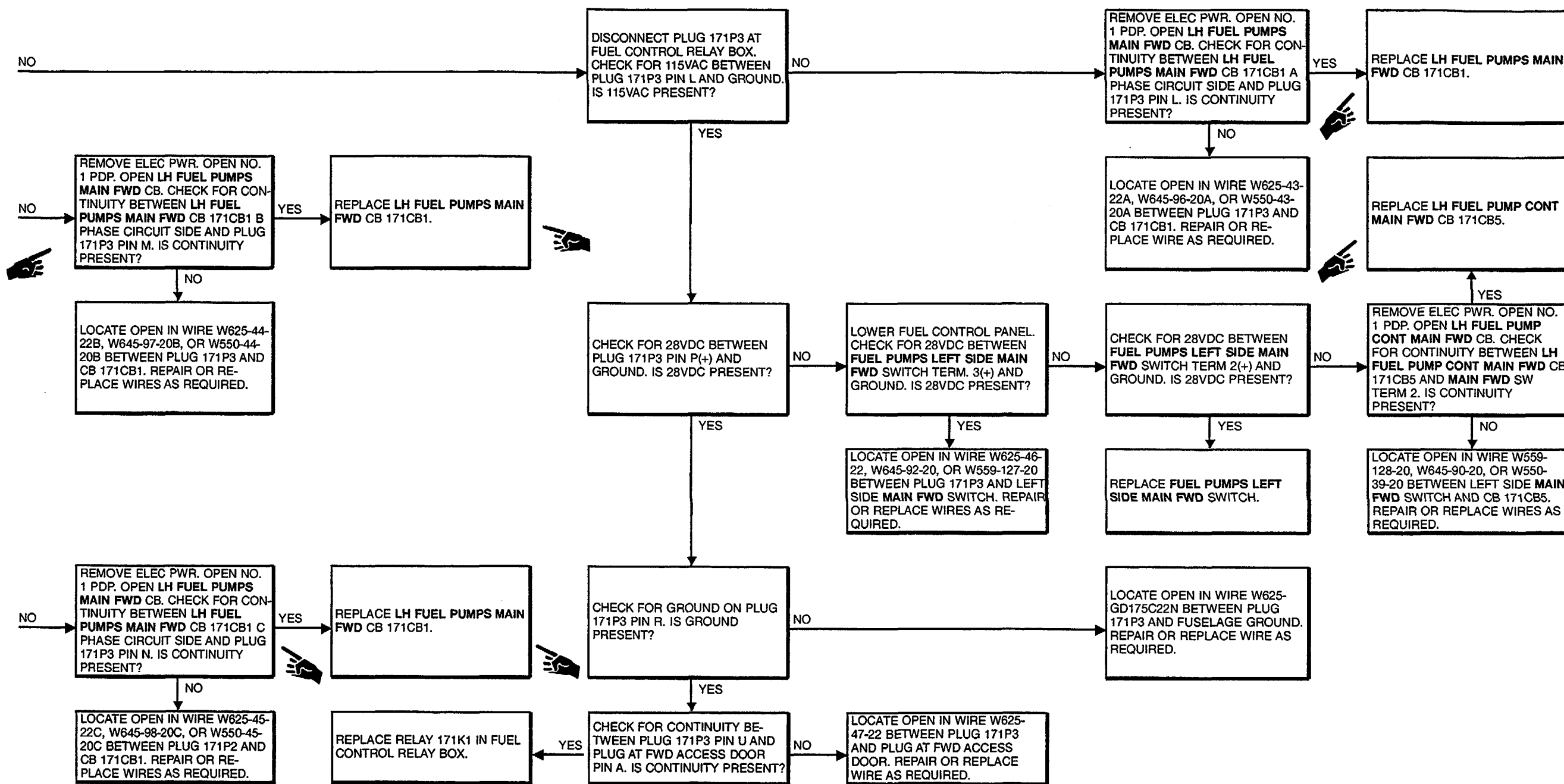

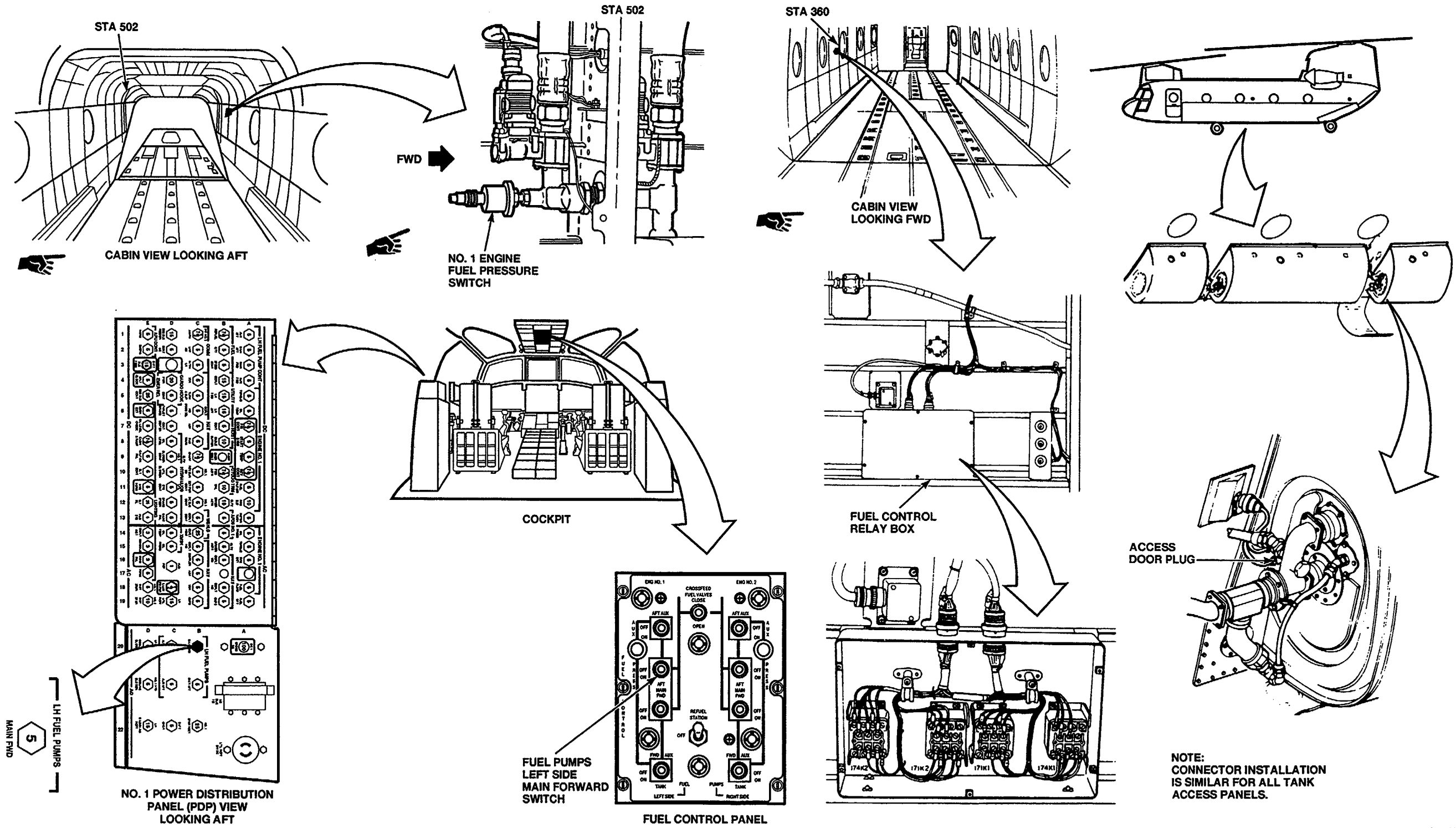

A73596

10-2.24 R FUEL PRESS CAPSULE DOES NOT GO OUT WHEN RIGHT SIDE MAIN FWD FUEL PUMPS SWITCH IS SET TO ON

FAULT ISOLATION PROCEDURE

INITIAL SETUP

Applicable Configurations:

All

Tools:

Electrical Repairer's Tool Kit,
NSN 5180-00-323-4915
Multimeter

Materials:

None

Personnel Required:

Aircraft Electrician (2)

References:

TM 55-1520-240-10
TM 55-1520-240-23

Equipment Condition:

TM 55-1520-240-10:
Both Engines Shut Down
TM 55-1520-240-23:
Battery Connected
Electrical Power On
Hydraulic Power Off
Side Acoustical Blanket Removed Between Sta 320
and 360
Right Fwd Landing Gear Access Panel Open

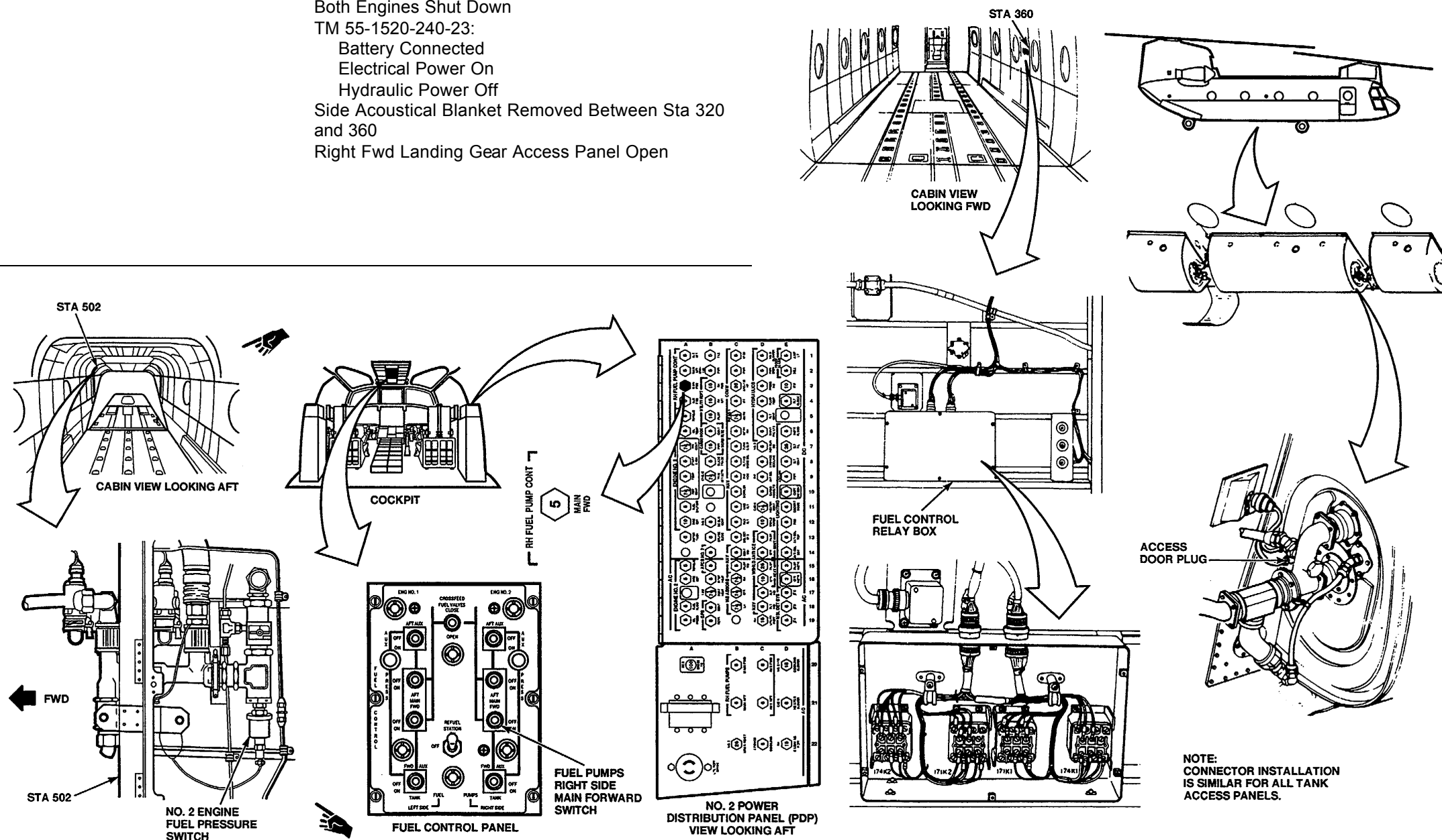

A84925

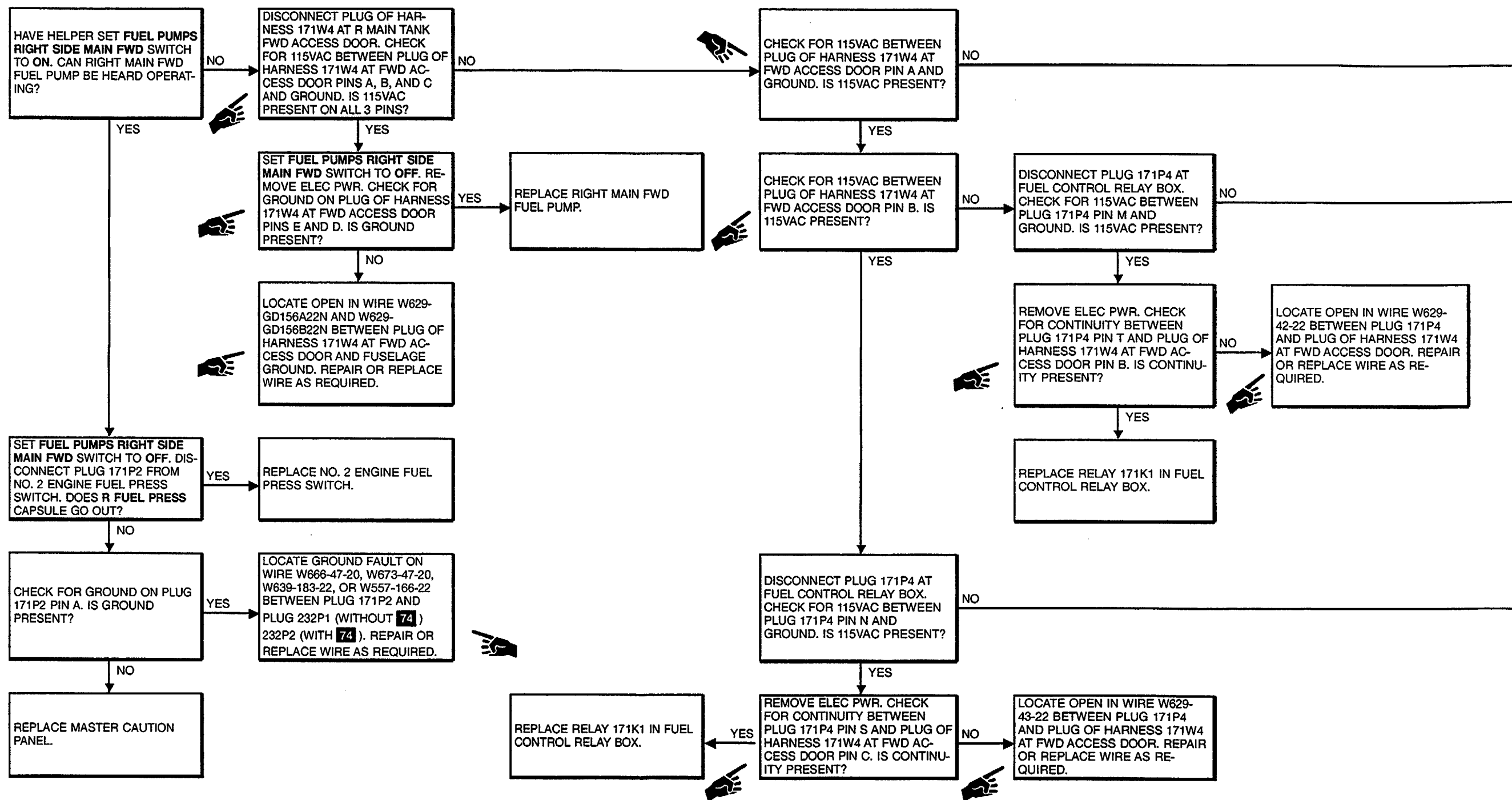

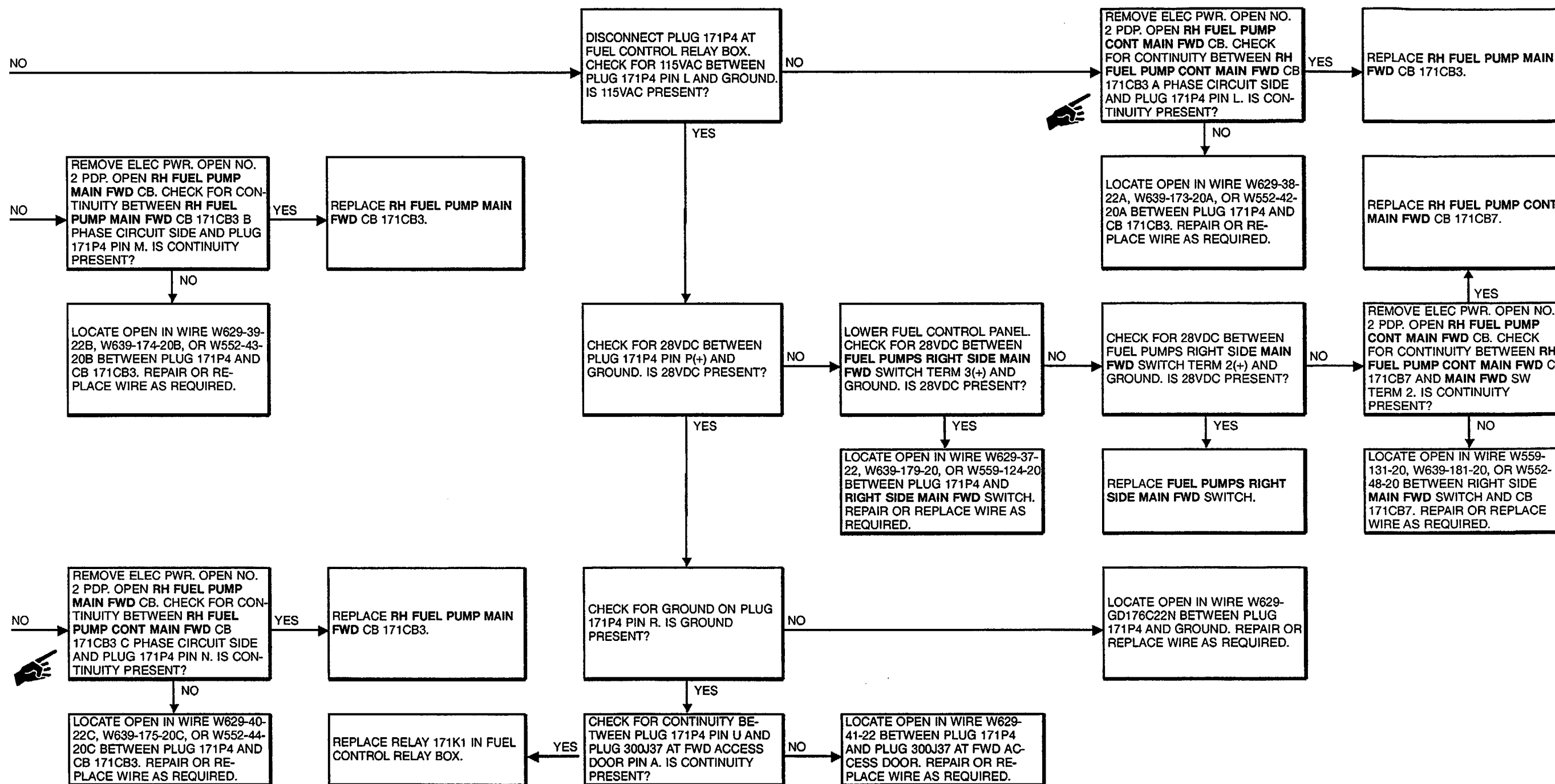

GO TO NEXT PAGE

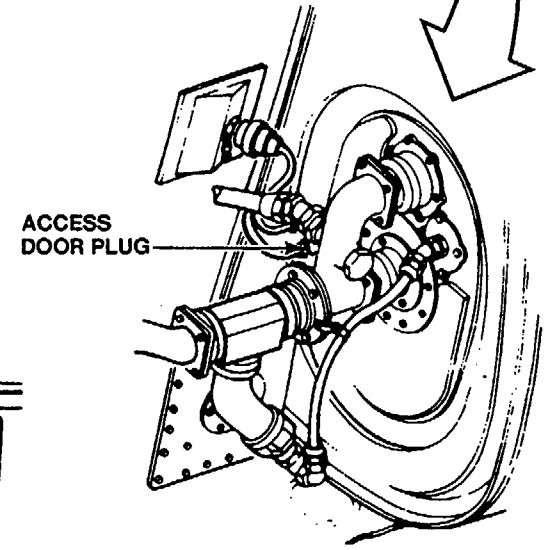
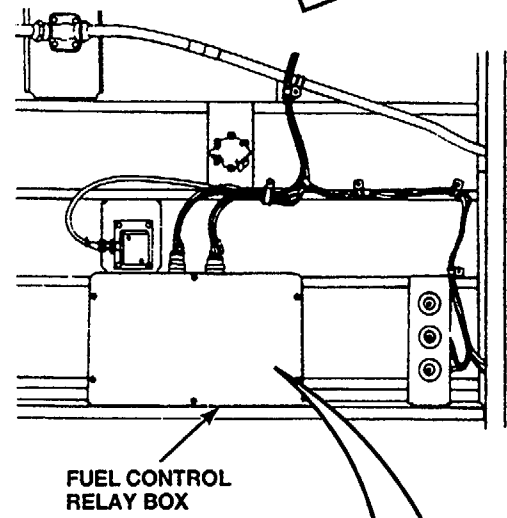
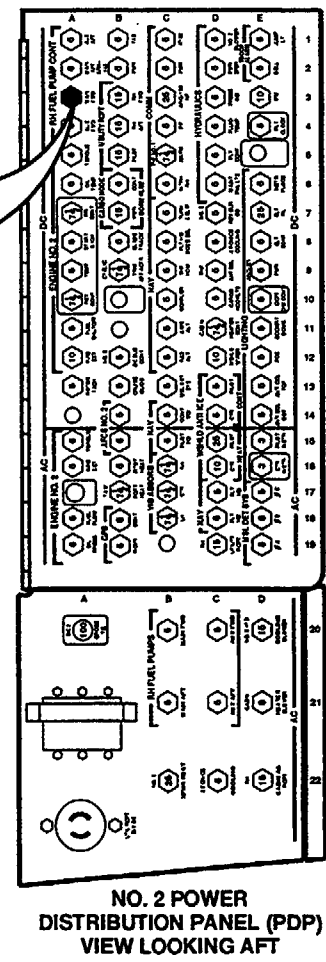
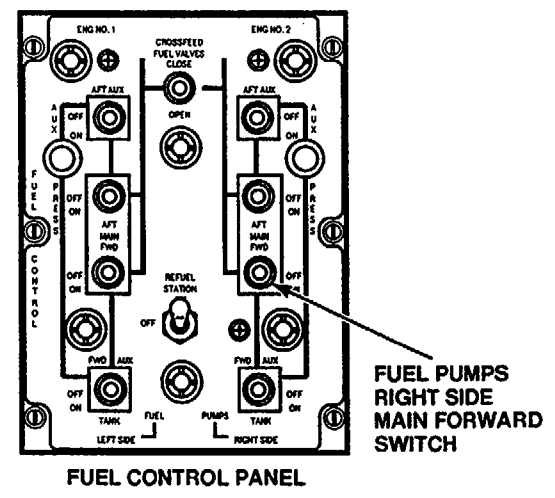
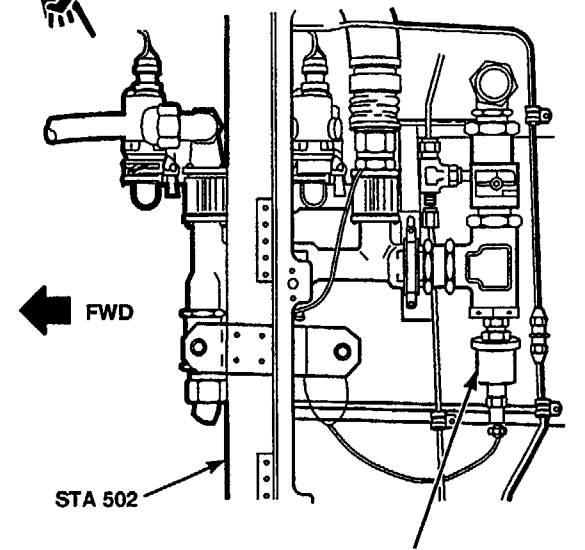
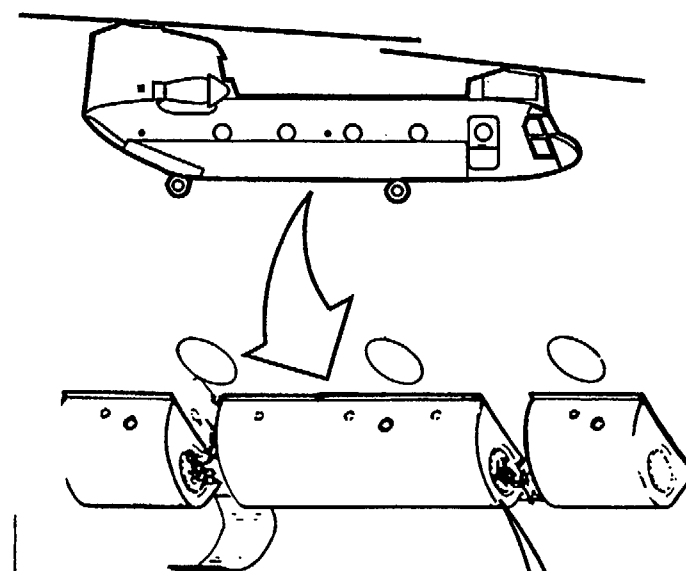
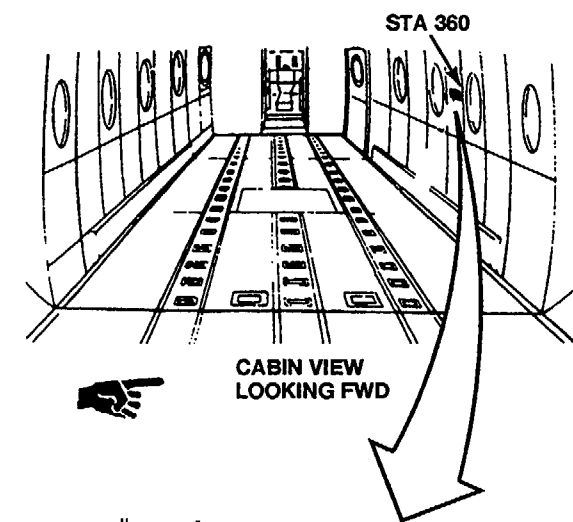
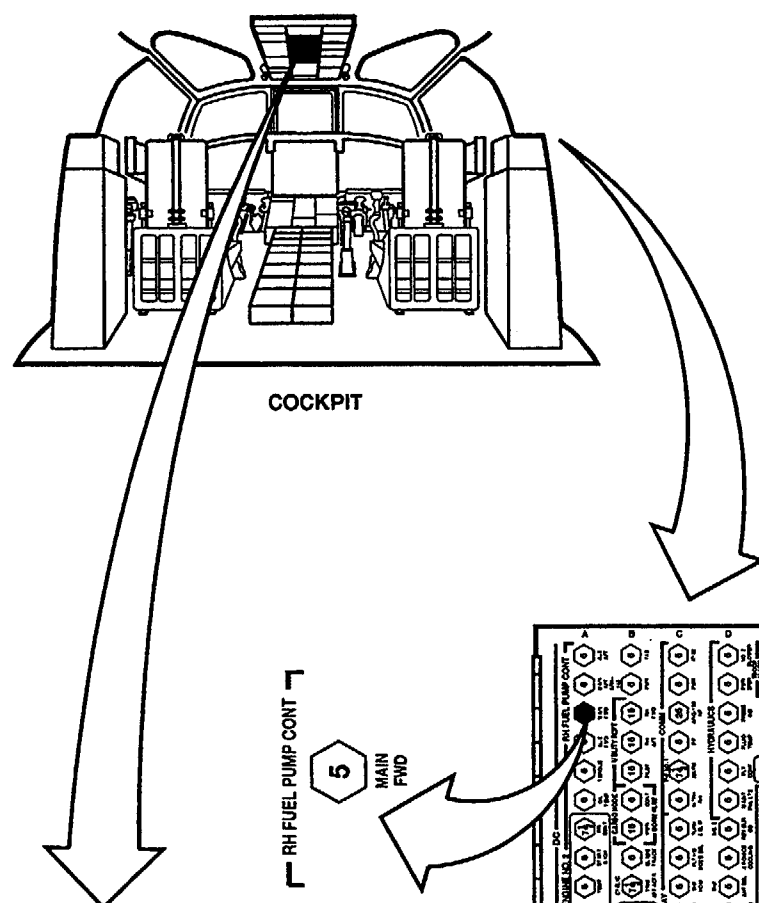
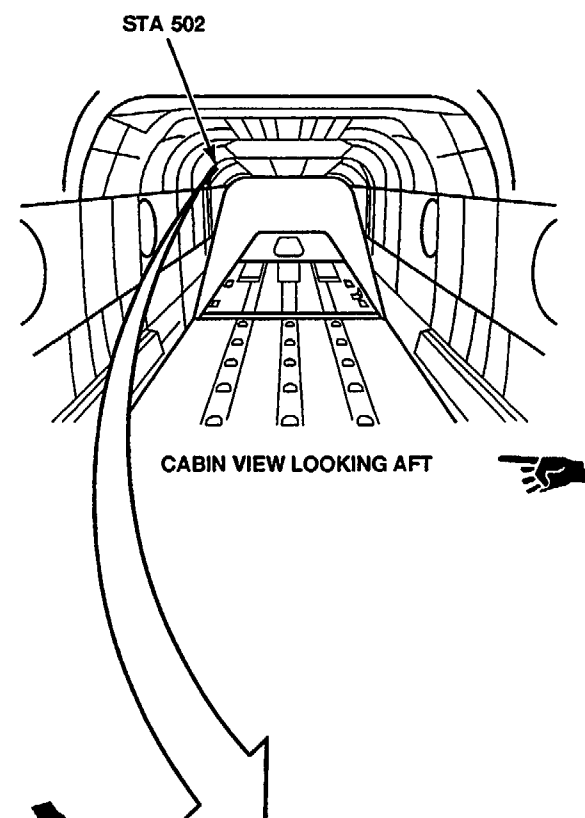

NOTE:
CONNECTOR INSTALLATION
IS SIMILAR FOR ALL TANK
ACCESS PANELS.

10-2.25 R FUEL PRESS CAPSULE DOES NOT GO OUT WHEN RIGHT SIDE MAIN AFT FUEL PUMPS SWITCH IS SET TO ON

FAULT ISOLATION PROCEDURE

INITIAL SETUP

Applicable Configurations:

All

Tools:

- Electrical Repairer's Tool Kit, NSN 5180-00-323-4915
- Multimeter

Materials:

None

Personnel Required:

- Aircraft Electrician (2)

References:

- TM 55-1520-240-10
- TM 55-1520-240-23

Equipment Condition:

- TM 55-1520-240-10 Both Engines Shut Down
- TM 55-1520-240-23: Battery Connected
- Electrical Power On
- Hydraulic Power Off
- Side Acoustical Blanket Removed Between Sta 320 and 360
- Right Side Intertank Access Panel Open

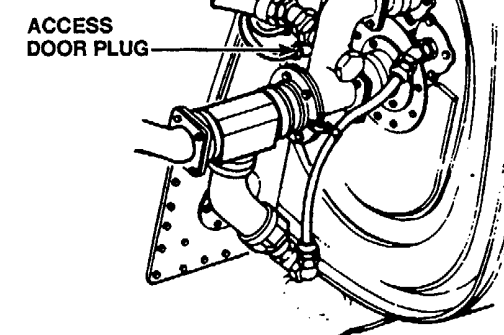
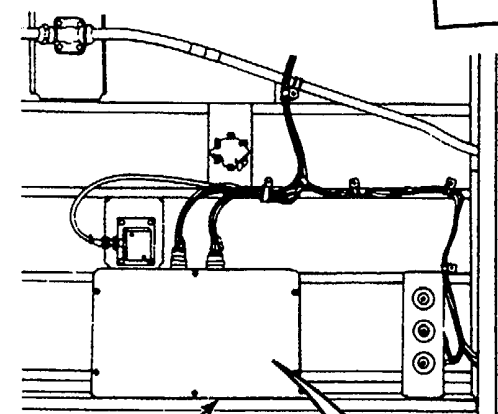
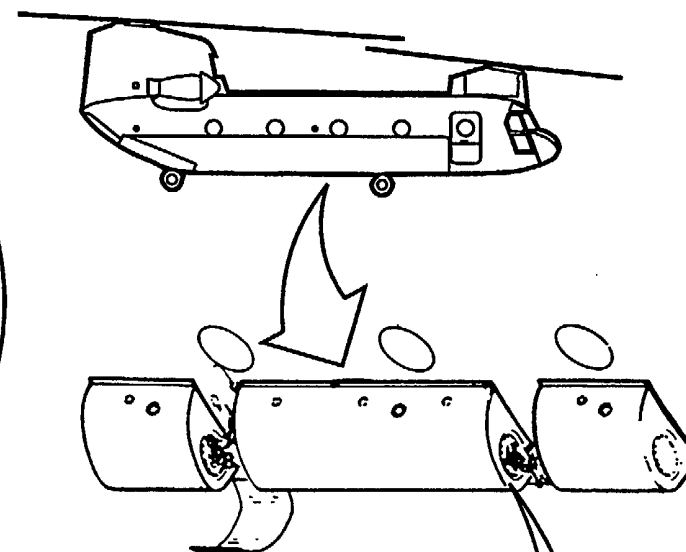
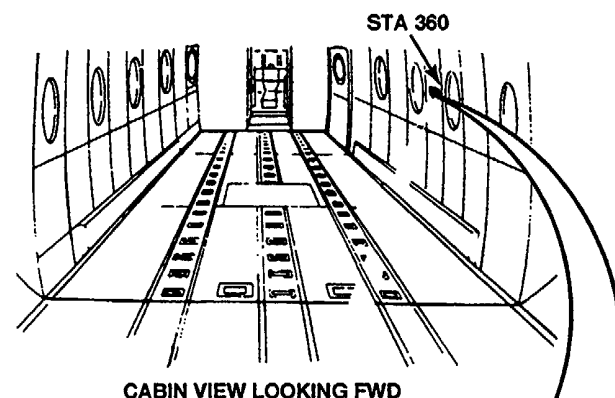

NOTE:
CONNECTOR INSTALLATION IS SIMILAR FOR ALL TANK ACCESS PANELS.

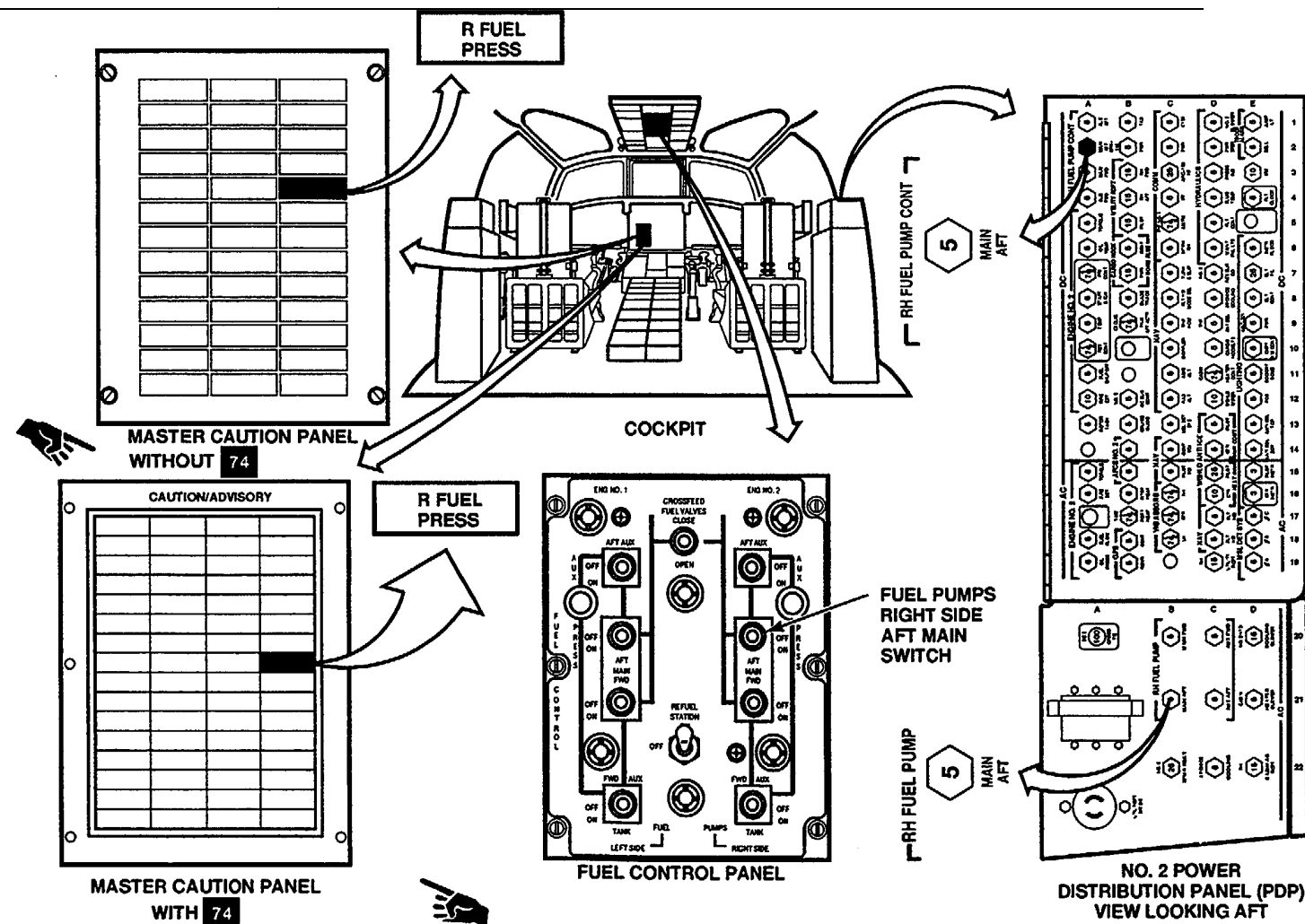

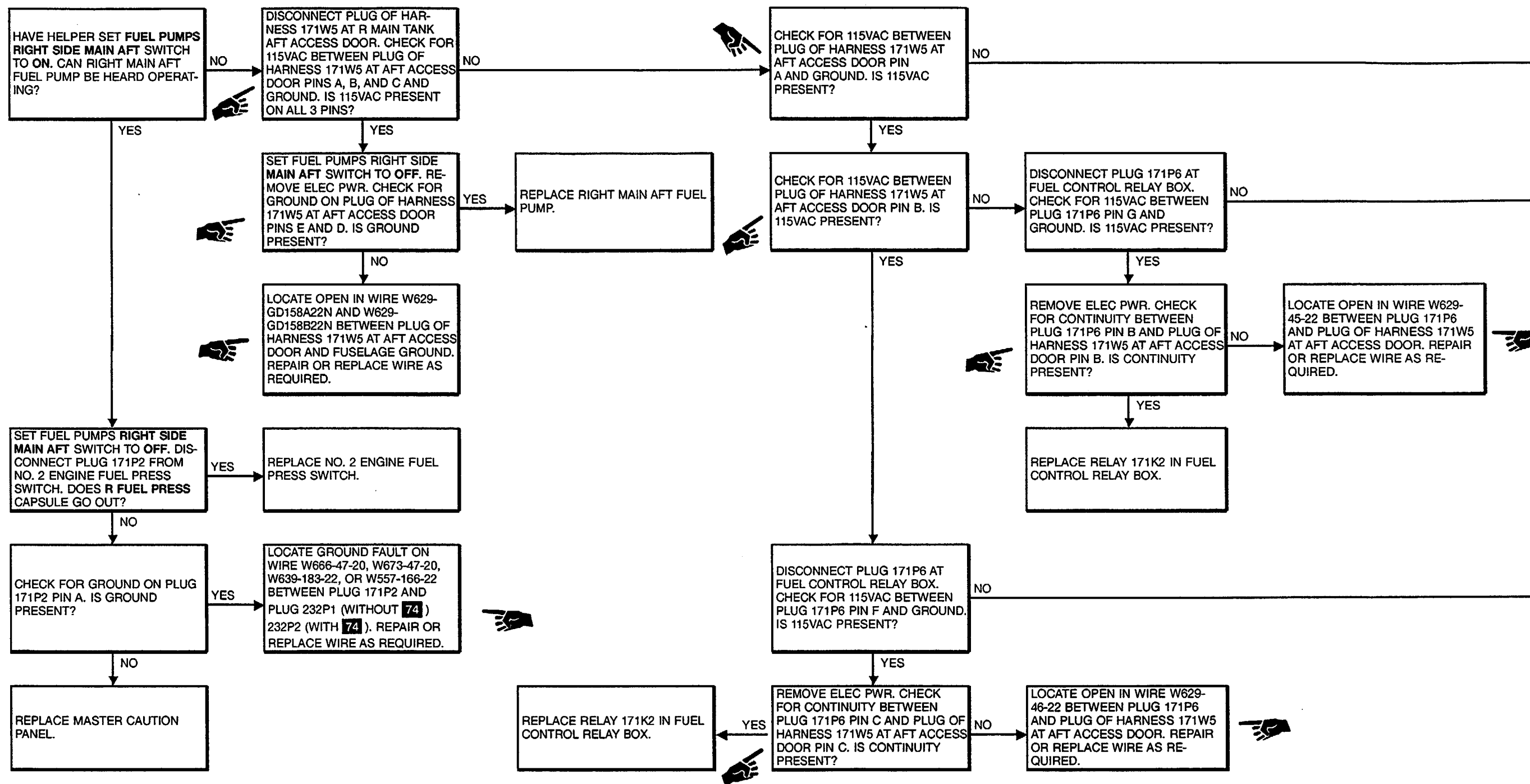

GO TO NEXT PAGE

Change 23 10-95

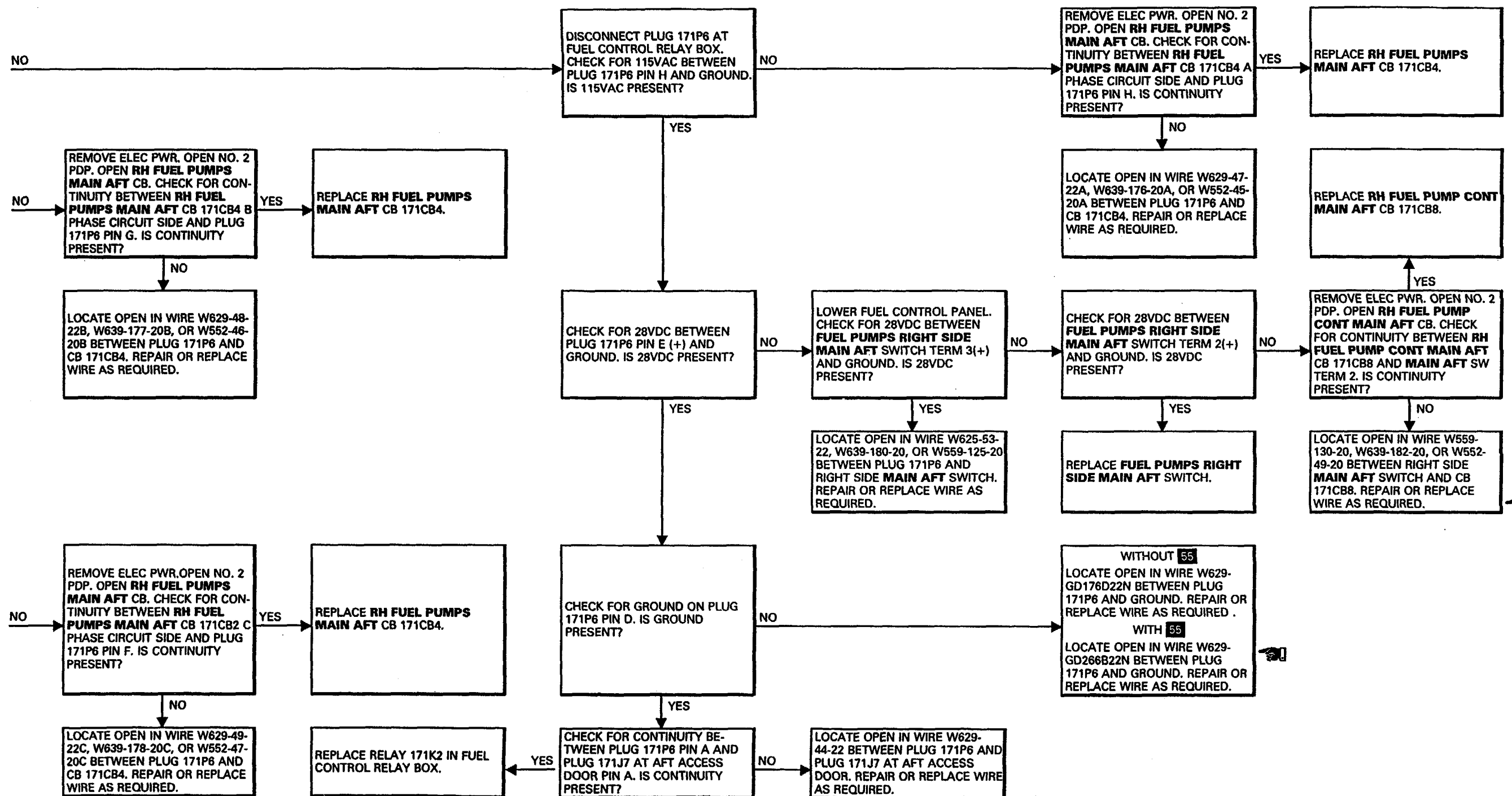

GO TO NEXT PAGE

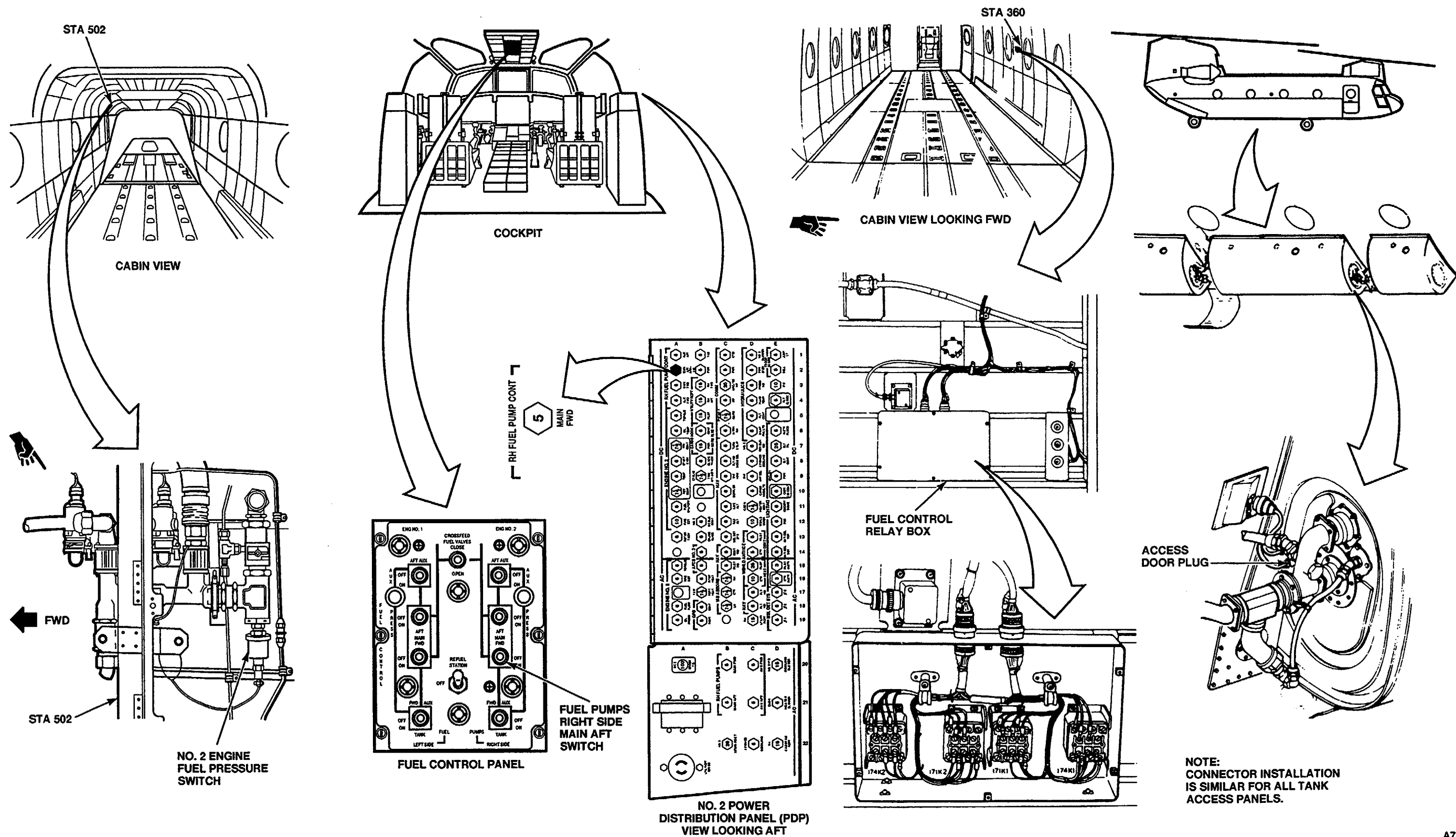

NOTE:
CONNECTOR INSTALLATION
IS SIMILAR FOR ALL TANK
ACCESS PANELS.

10-2.26 LEFT SIDE AUX PRESS LIGHT COMES ON WHEN LEFT SIDE AFT AUX FUEL PUMP SWITCH IS SET TO ON

FAULT ISOLATION PROCEDURE

INITIAL SETUP

Applicable Configurations:
All

Tools
Electrical Repairer's Tool Kit,
NSN 5180-00-323-4915

Materials:
None

Personnel Required:
Aircraft Electrician (2)

References:
TM 55-1520-240-23

Equipment Condition:
TM 55-1520-240-23:
Battery Connected
Electrical Power On
Hydraulic Power Off
Side Acoustical Blanket Removed Between Sta 320 and 360
Left Aft Intertank Access Panel Open

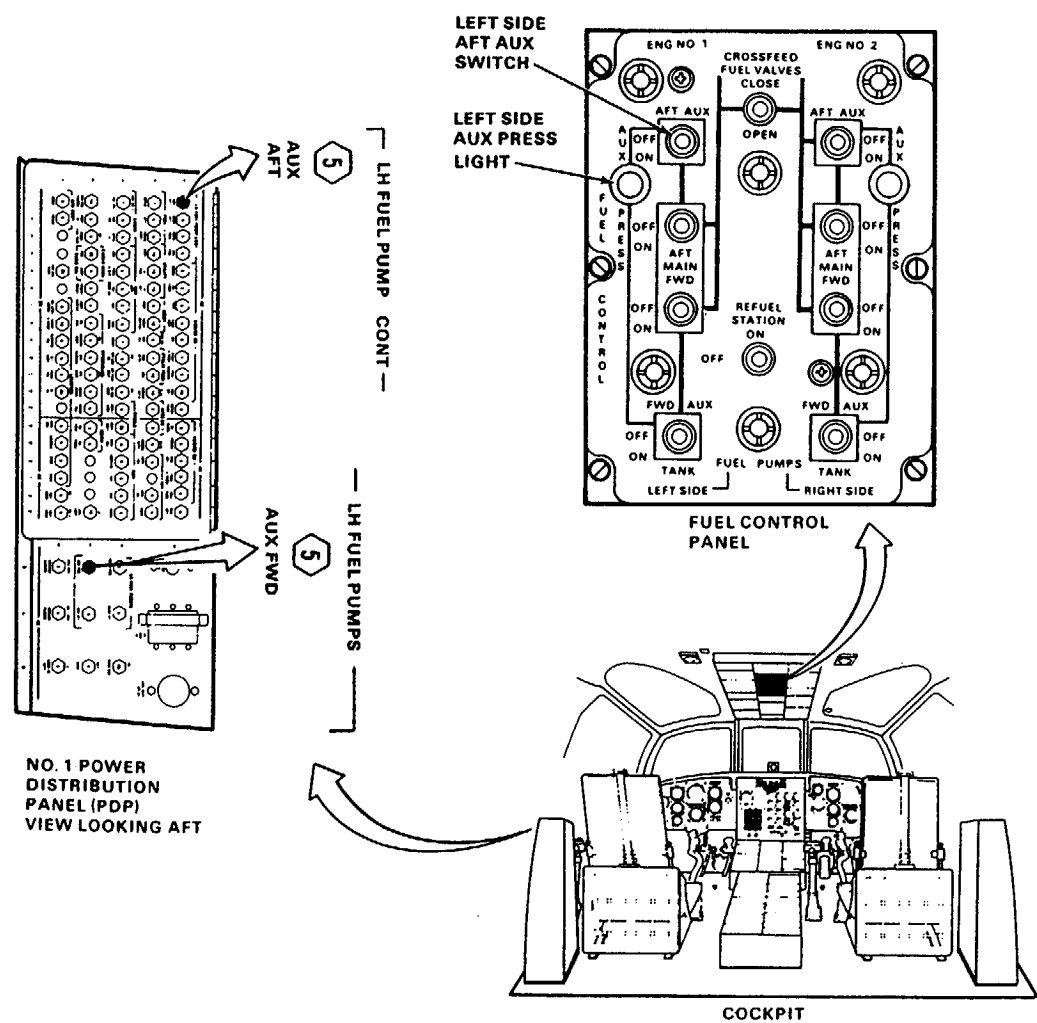
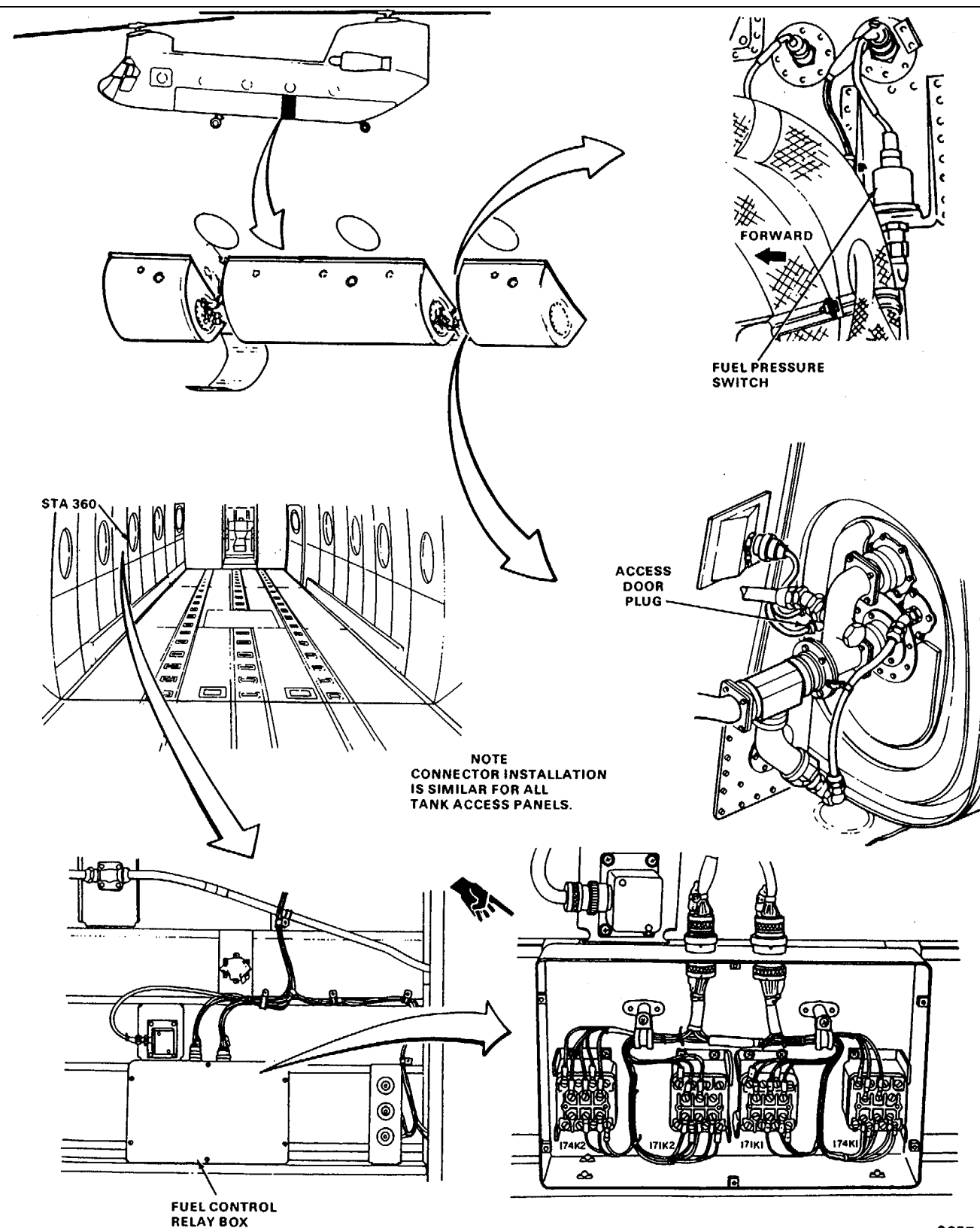

10-2.26 LEFT SIDE AUX PRESS LIGHT COMES ON WHEN LEFT SIDE AFT AUX FUEL PUMP SWITCH IS SET TO ON (Continued)

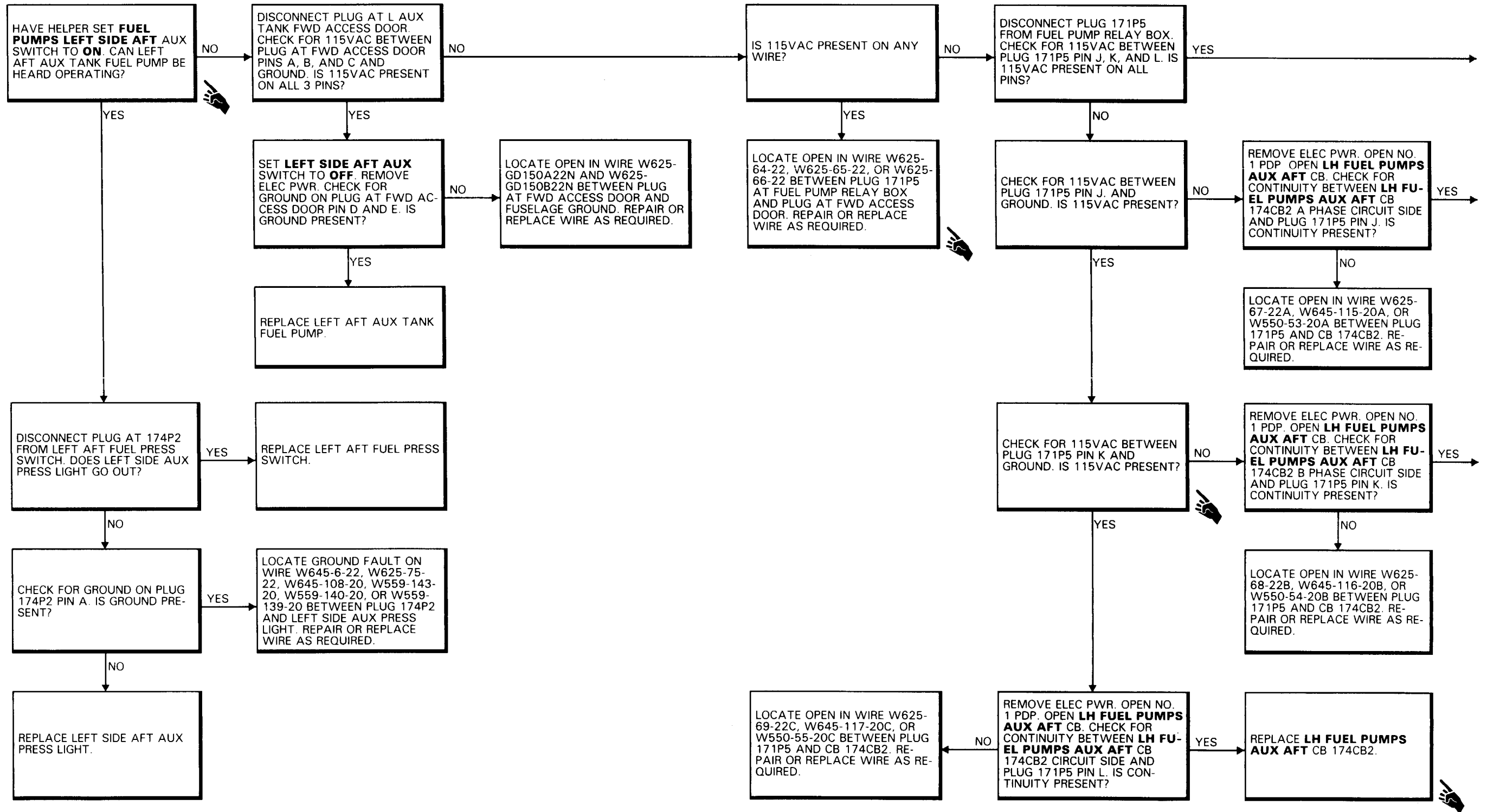

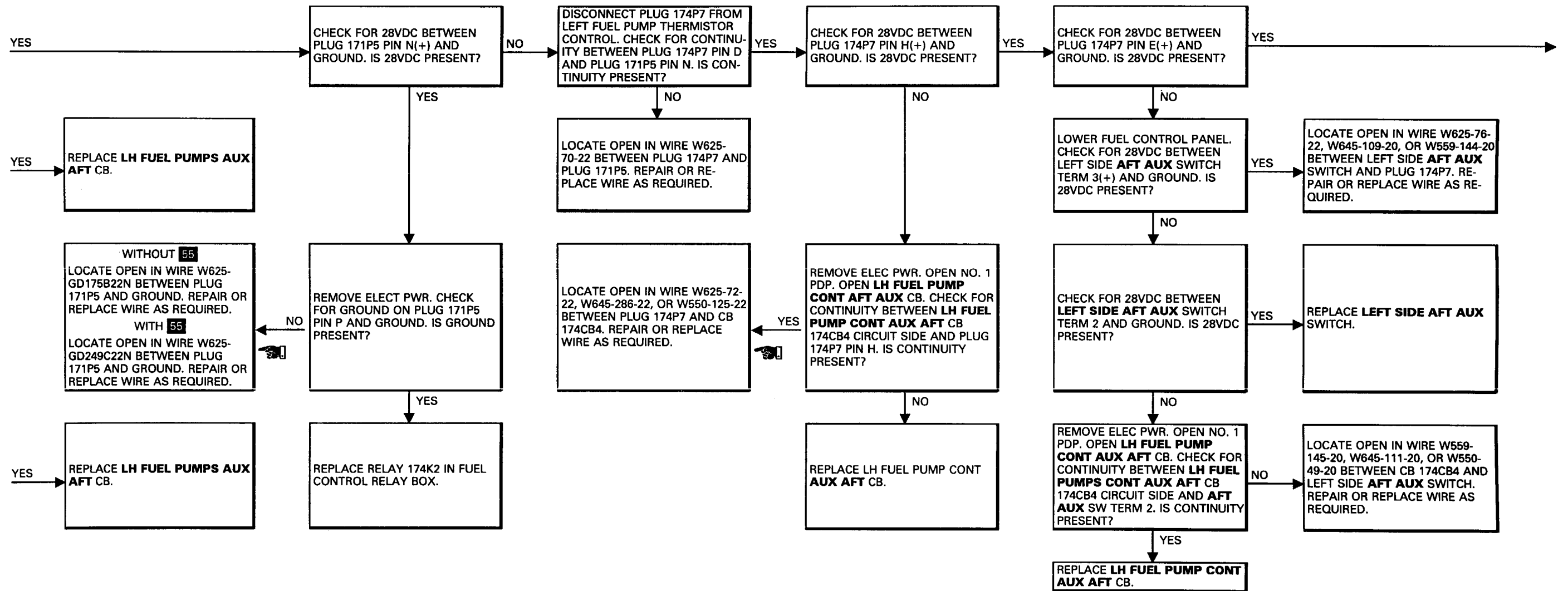

10-2.26 LEFT SIDE AUX PRESS LIGHT COMES ON
WHEN LEFT SIDE AFT AUX FUEL PUMP
SWITCH IS SET TO ON (Continued)

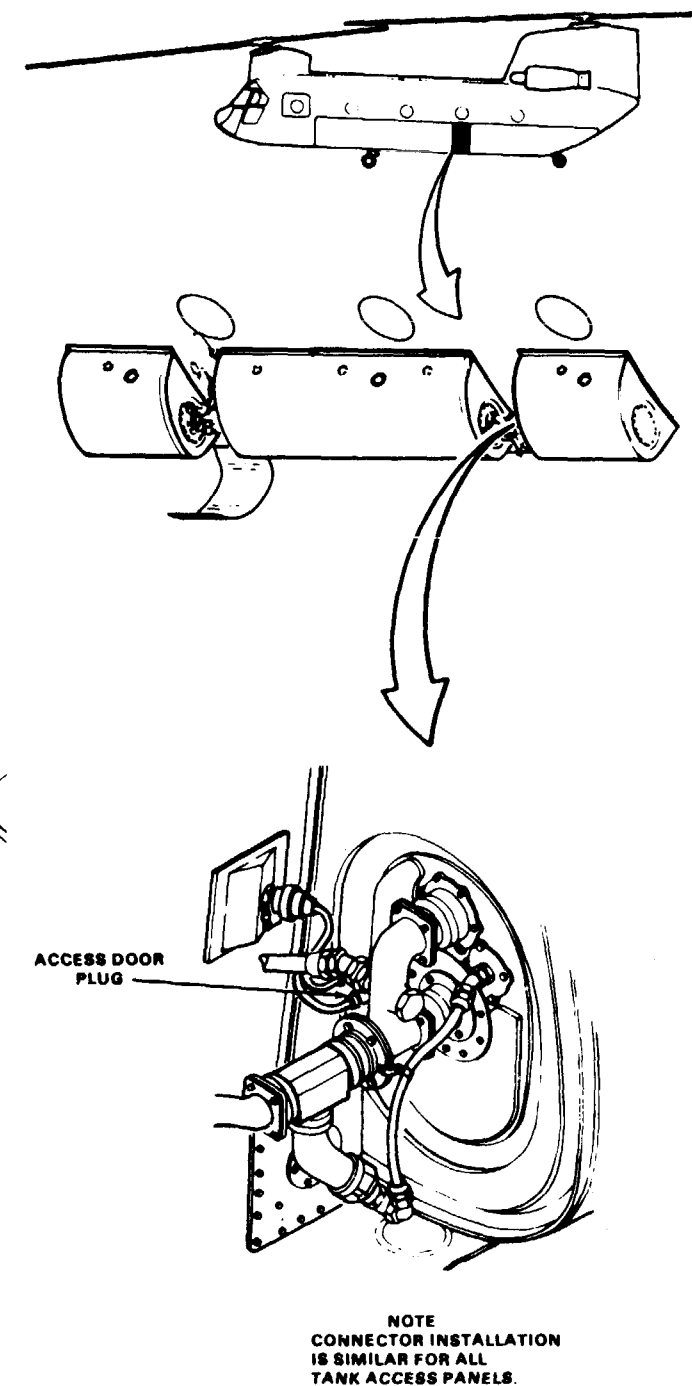
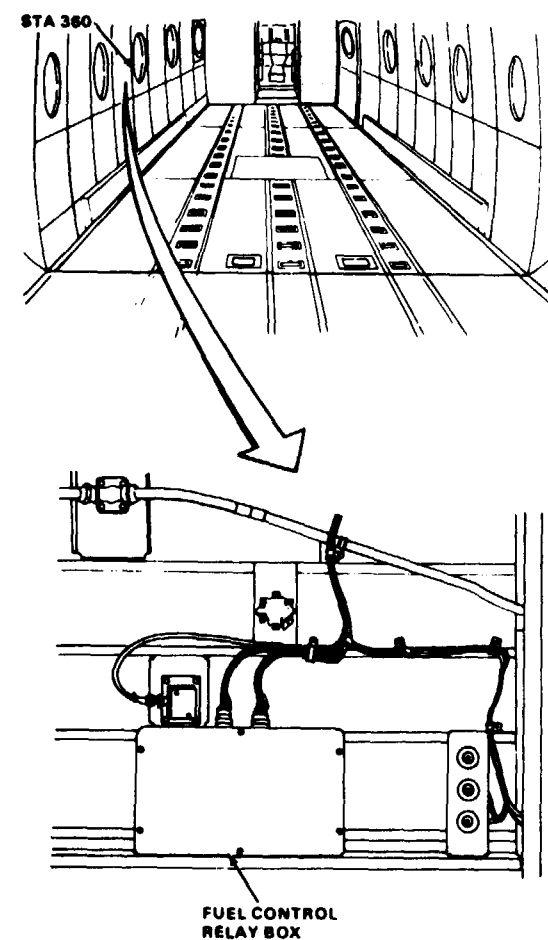
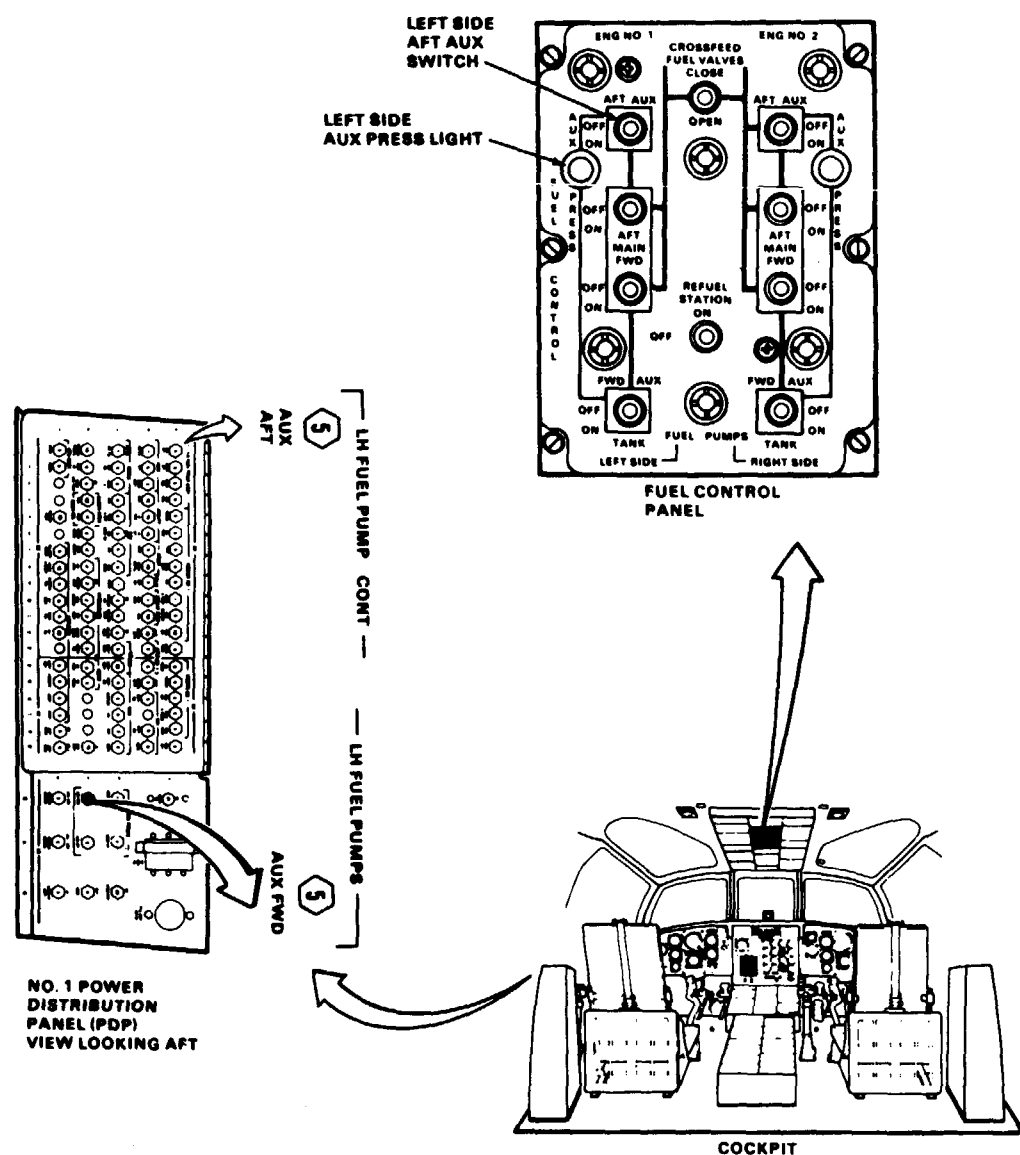

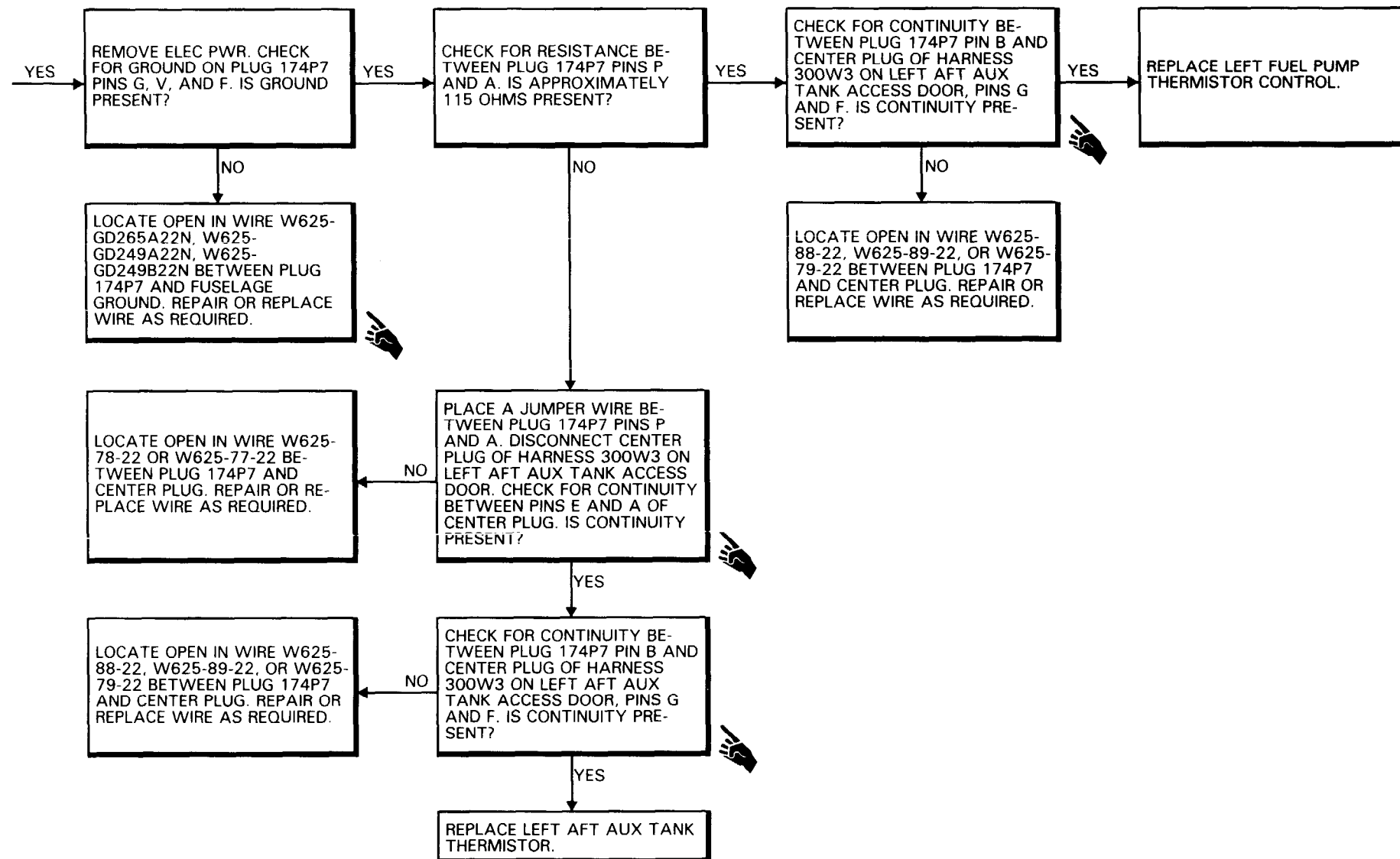

10-2.26 LEFT SIDE AUX PRESS LIGHT COMES ON WHEN LEFT SIDE AFT AUX FUEL PUMP SWITCH IS SET TO ON (Continued)

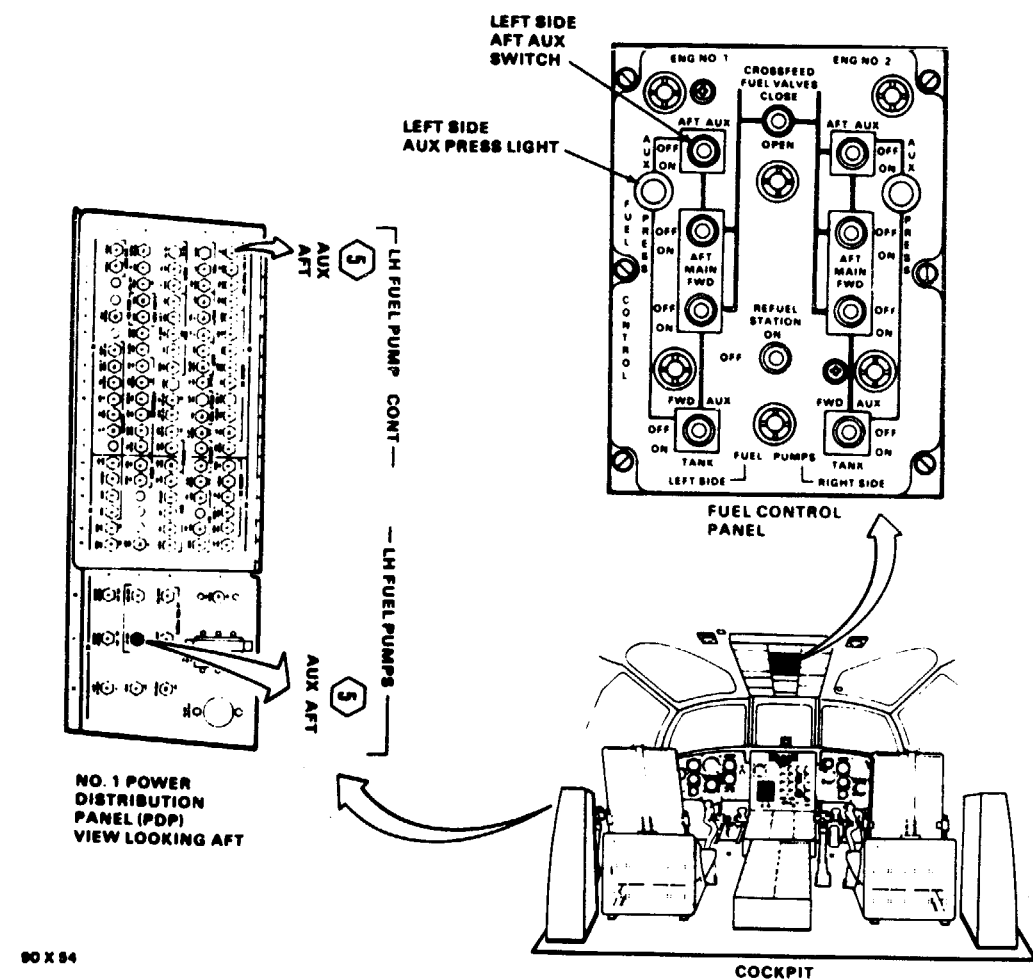

90 X 54

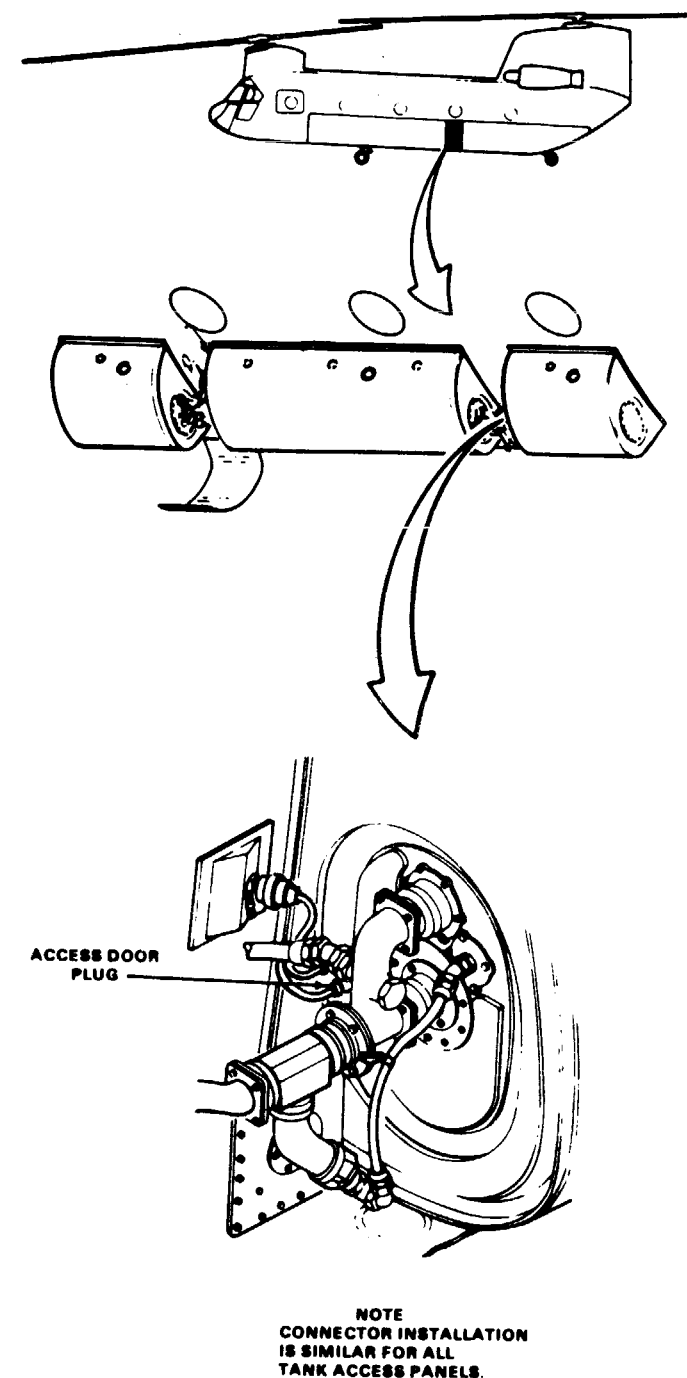
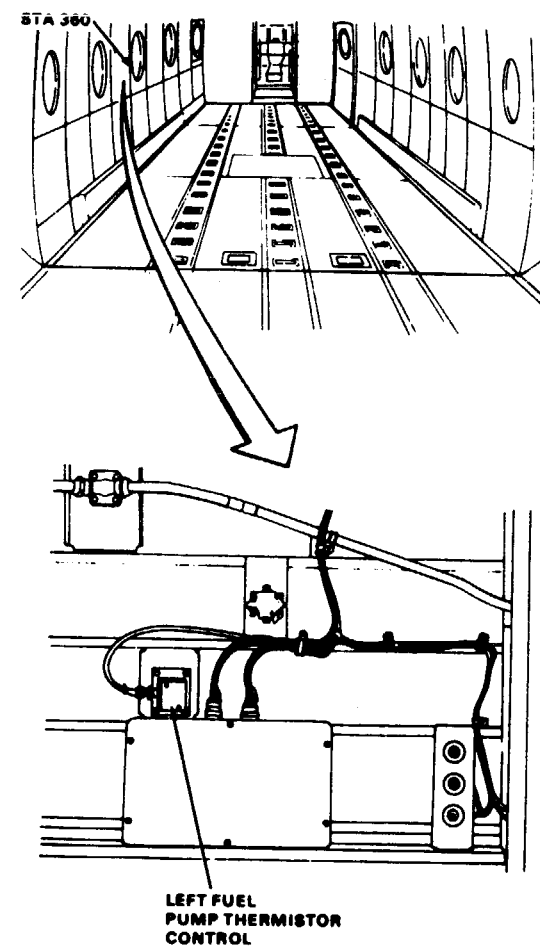

D145-11759-8PA

END OF TASK

FAULT ISOLATION PROCEDURE

INITIAL SETUP

Applicable Configurations:

All

Tools:

Electrical Repairer's Tool Kit,
NSN 5180-00-323-4915
Multimeter

Materials:

None

Personnel Required:

Aircraft Electrician (2)

References:

TM 55-1520-240-23

Equipment Condition:

TM 55-1520-240-23:
Battery Connected
Electrical Power On
Hydraulic Power Off
Side Acoustical Blanket Removed Between Sta 320 and 360
Left Forward Landing Gear Access Panel Open

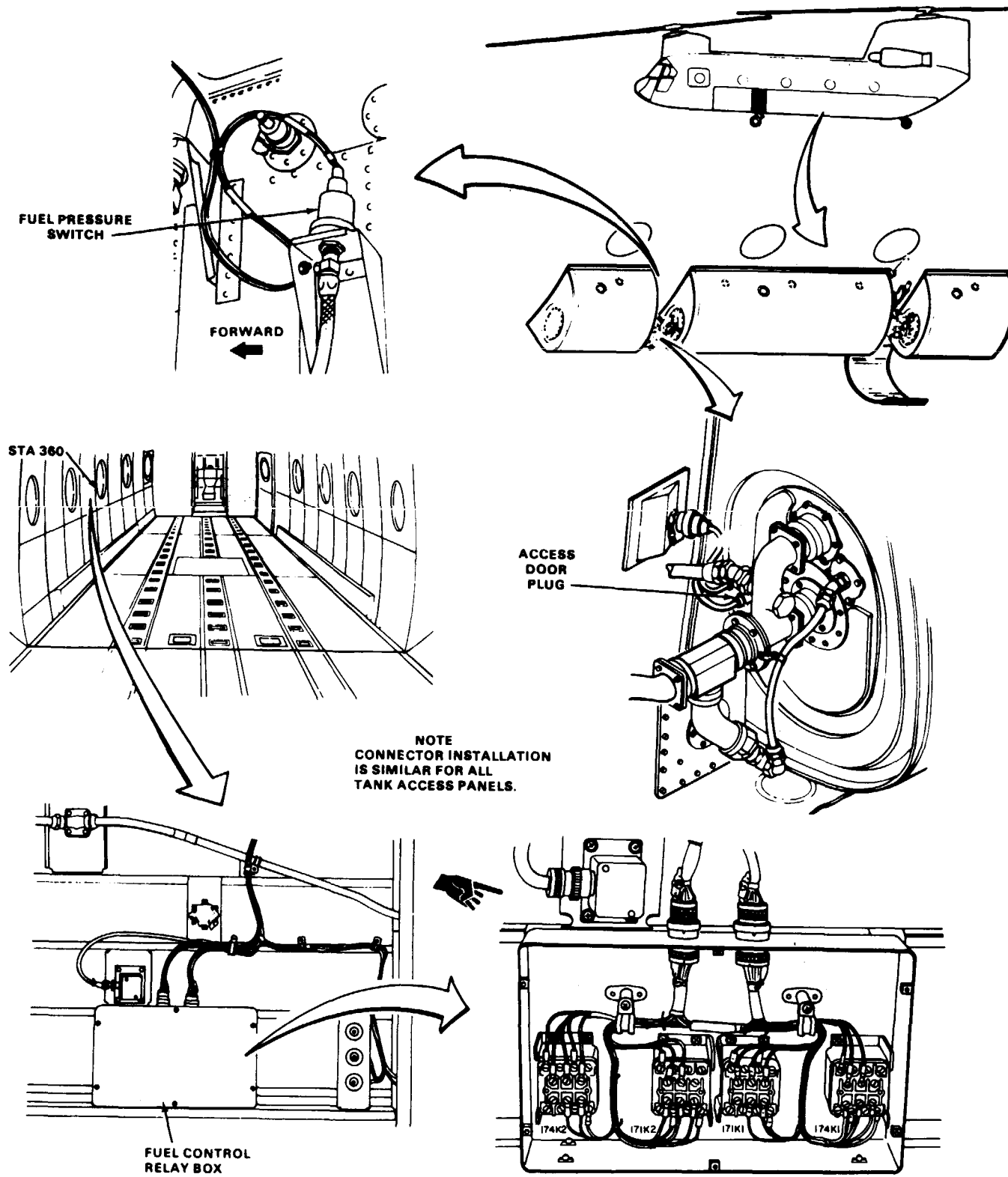
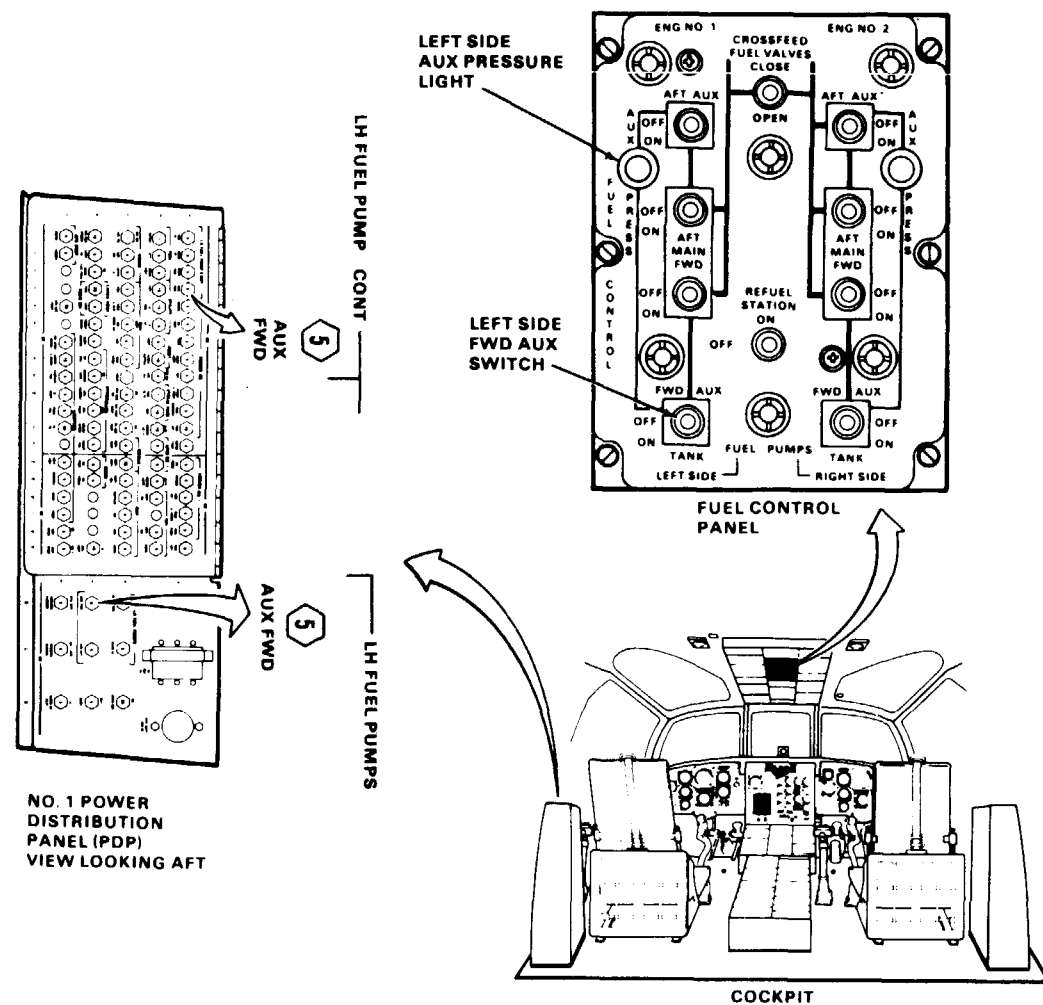

9638

GO TO NEXT PAGE

10-2.27 LEFT SIDE AUX PRESS LIGHT COMES ON WHEN LEFT SIDE FWD AUX FUEL PUMP SWITCH IS SET TO ON (Continued)

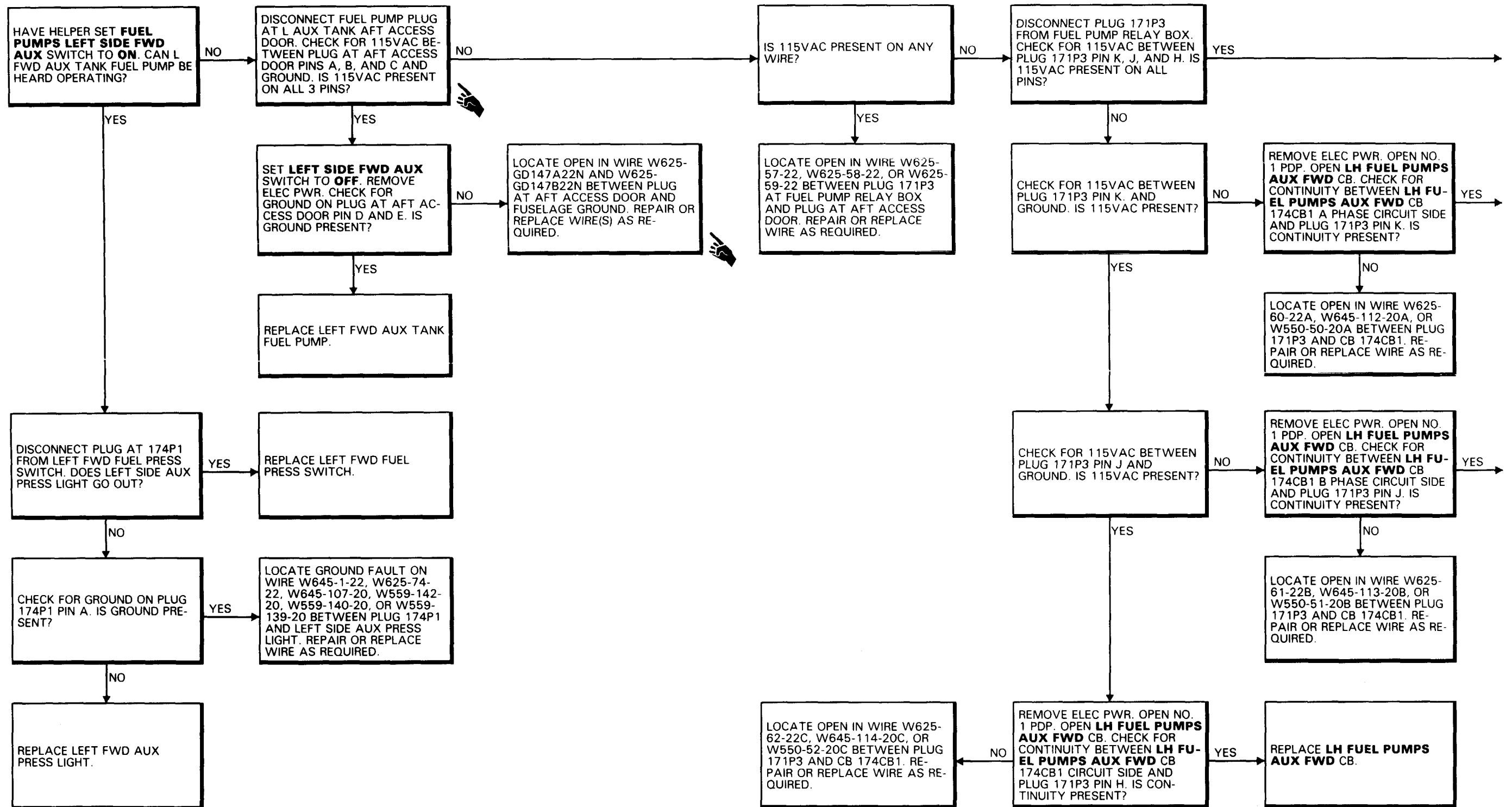

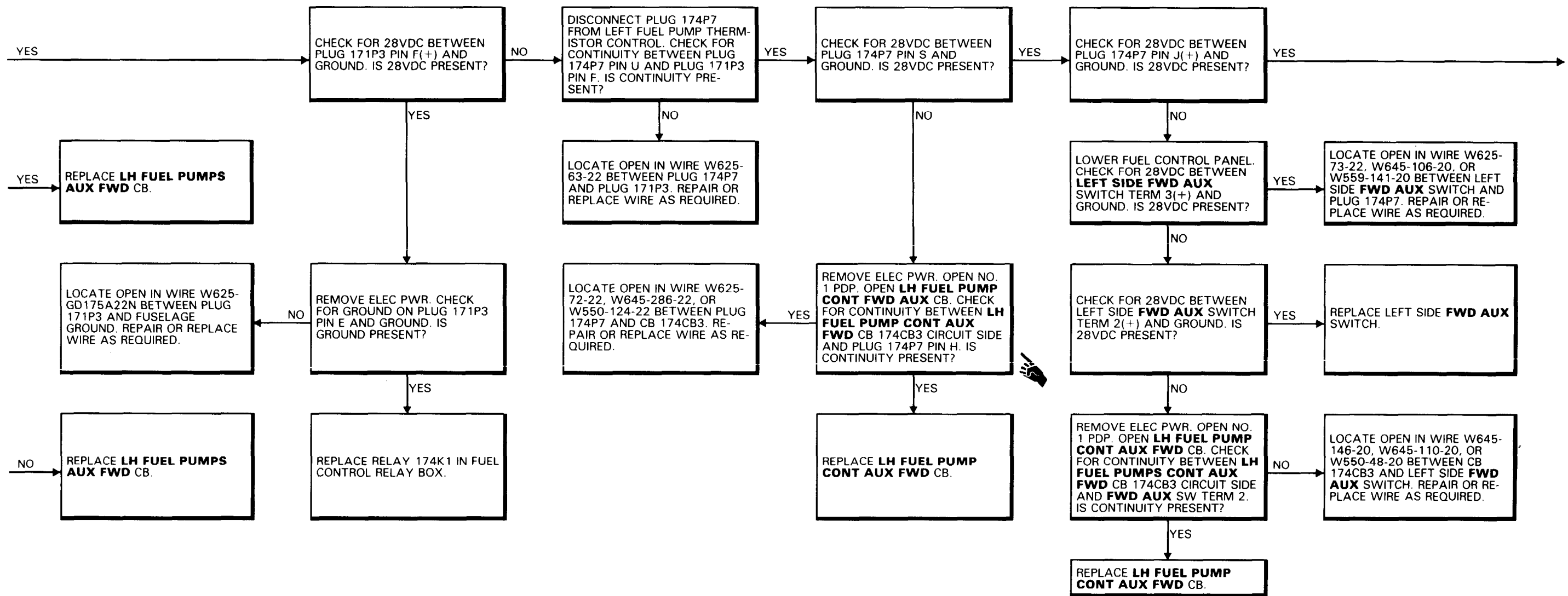

10-2.27 LEFT SIDE AUX PRESS LIGHT COMES ON WHEN LEFT SIDE FWD AUX FUEL PUMP SWITCH IS SET TO ON
(Continued)

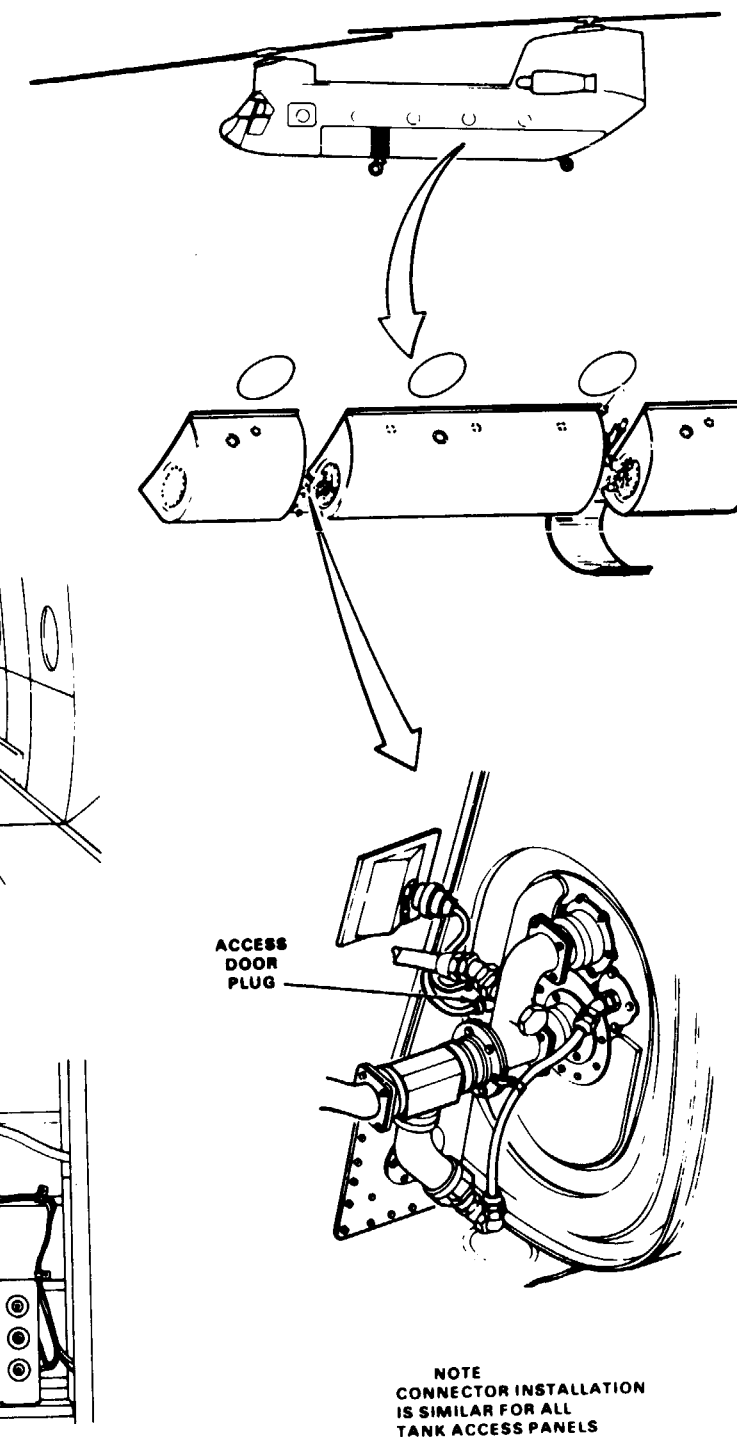
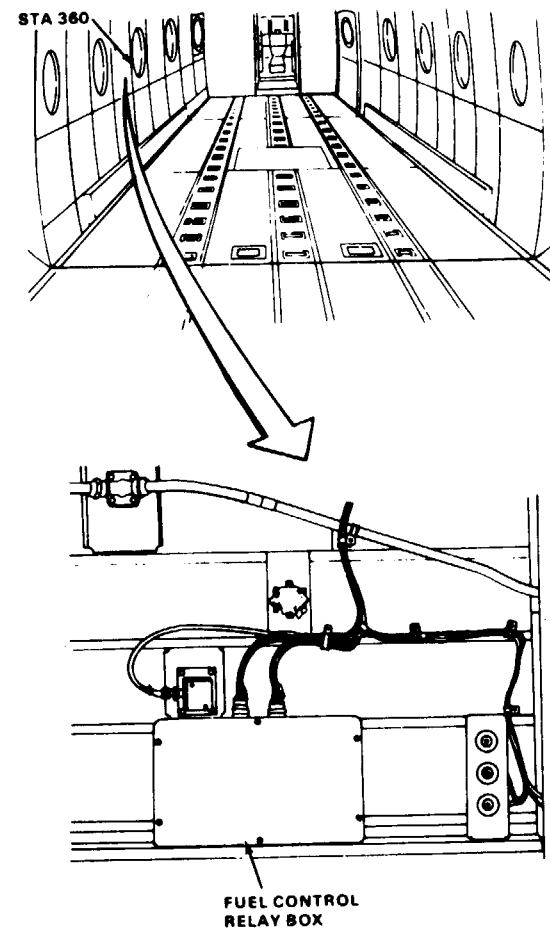
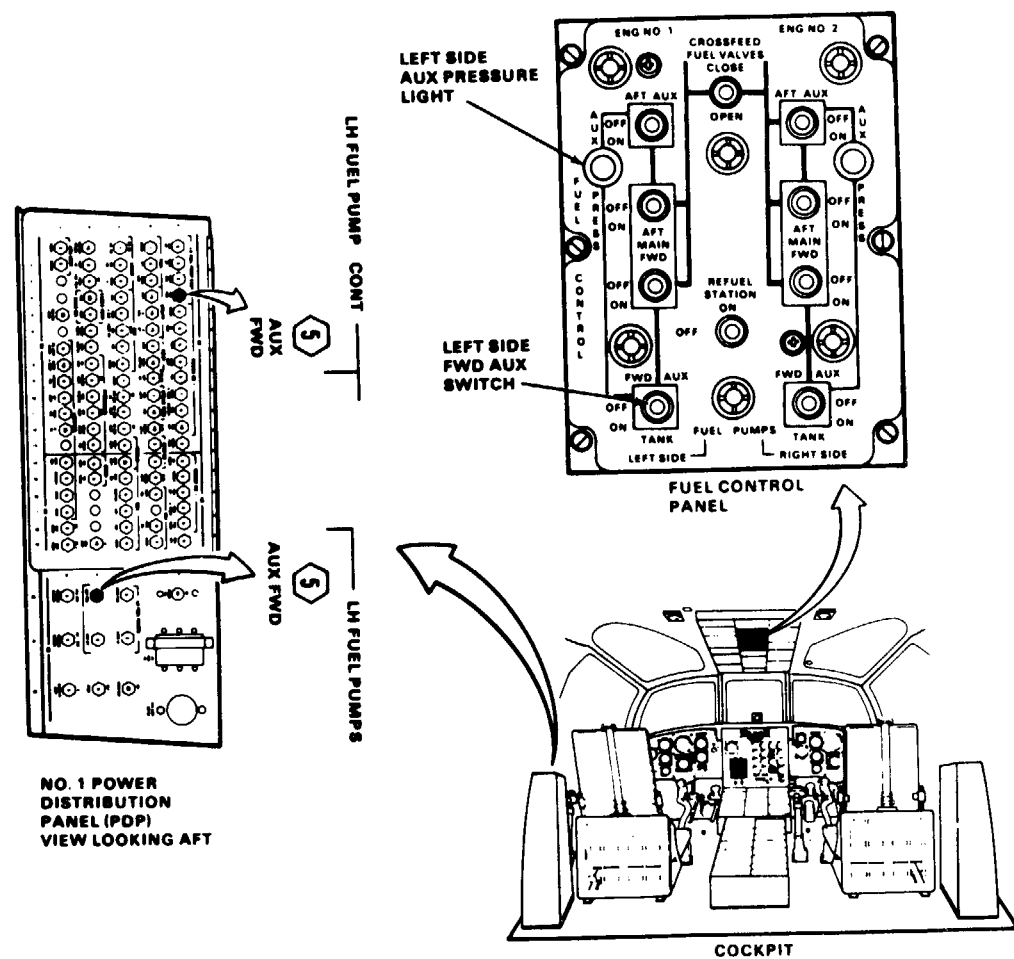

NOTE
CONNECTOR INSTALLATION
IS SIMILAR FOR ALL
TANK ACCESS PANELS

D145-11761-5PA

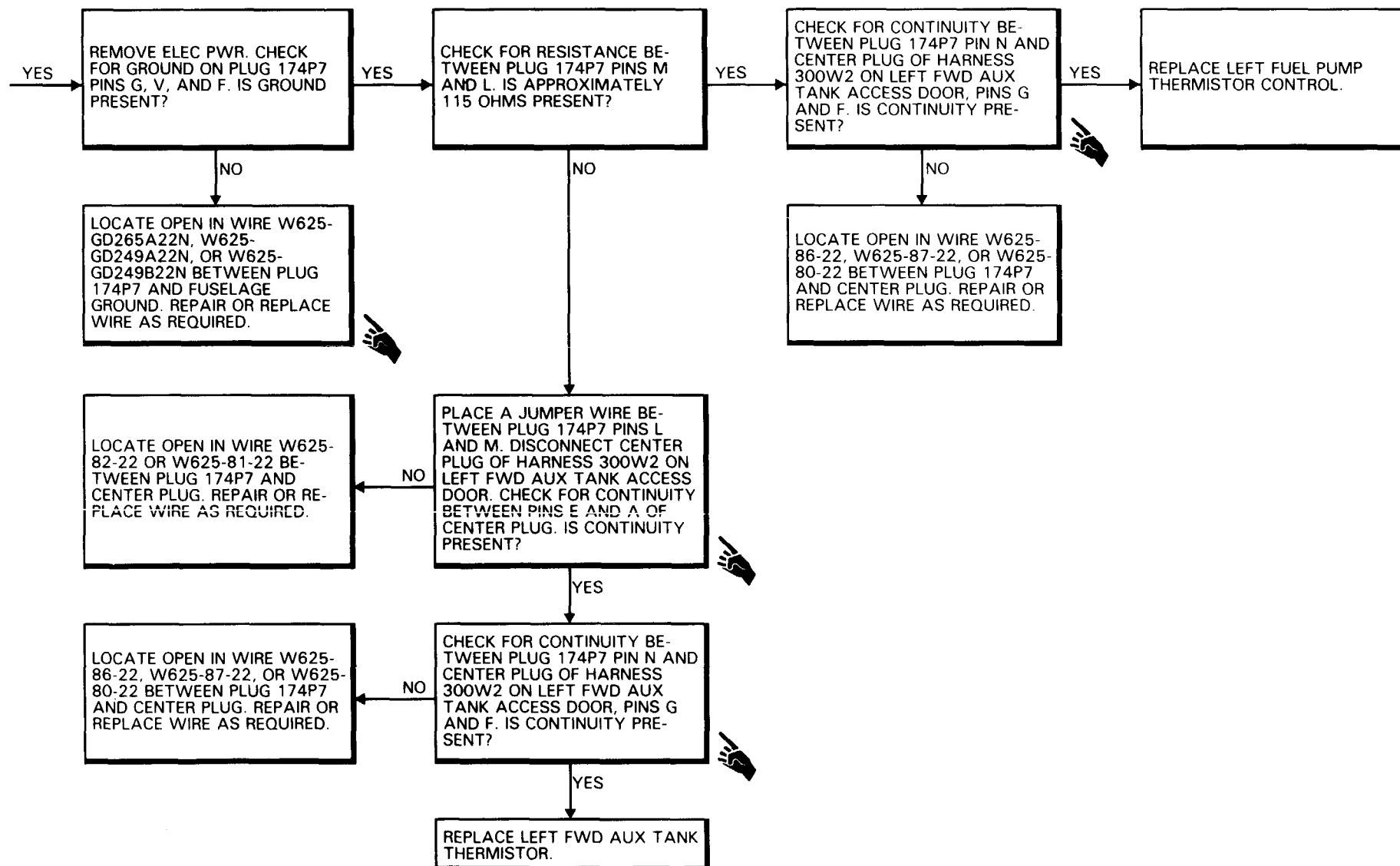

10-2.27 LEFT SIDE AUX PRESS LIGHT COMES ON WHEN LEFT SIDE FWD AUX FUEL PUMP SWITCH IS SET TO ON (Continued)

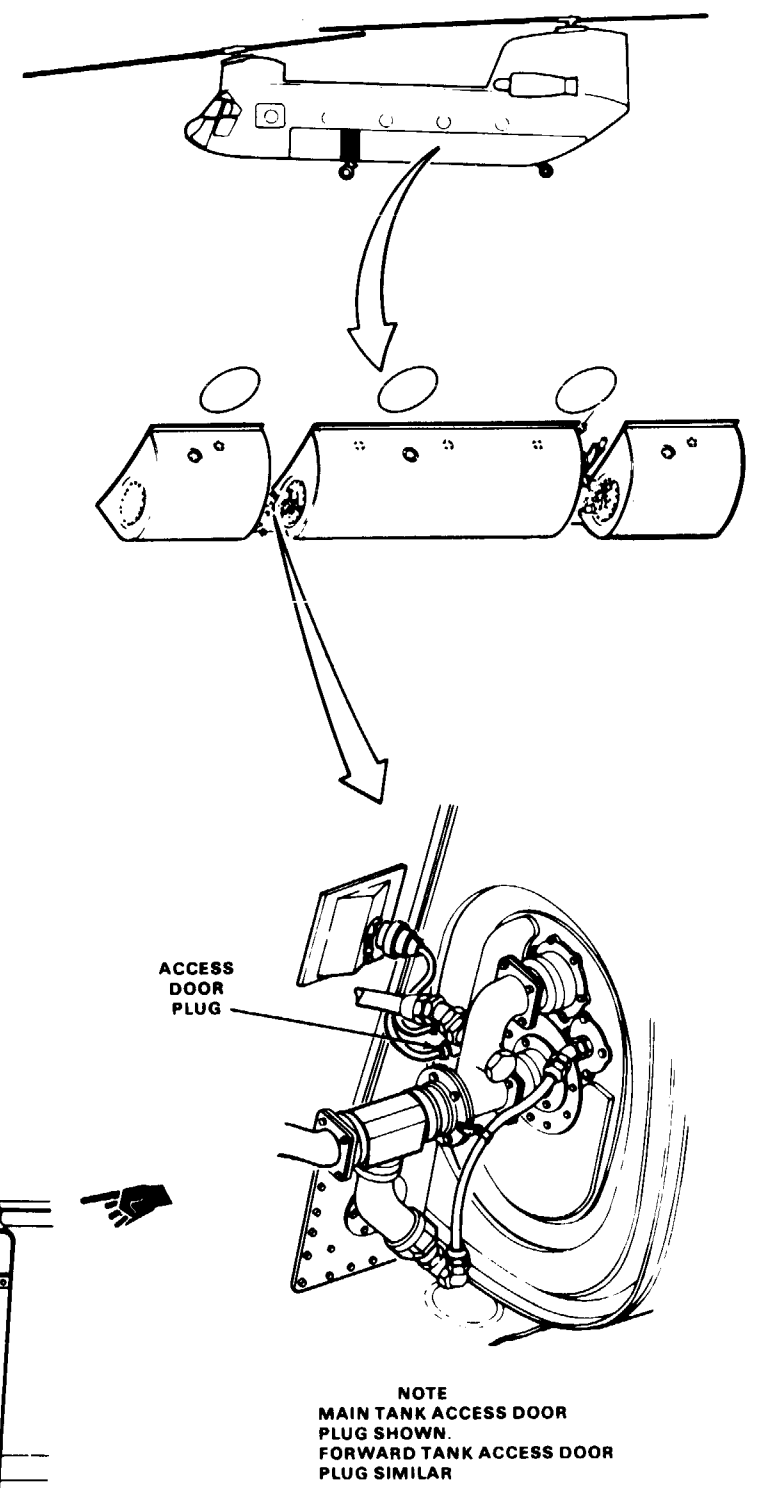
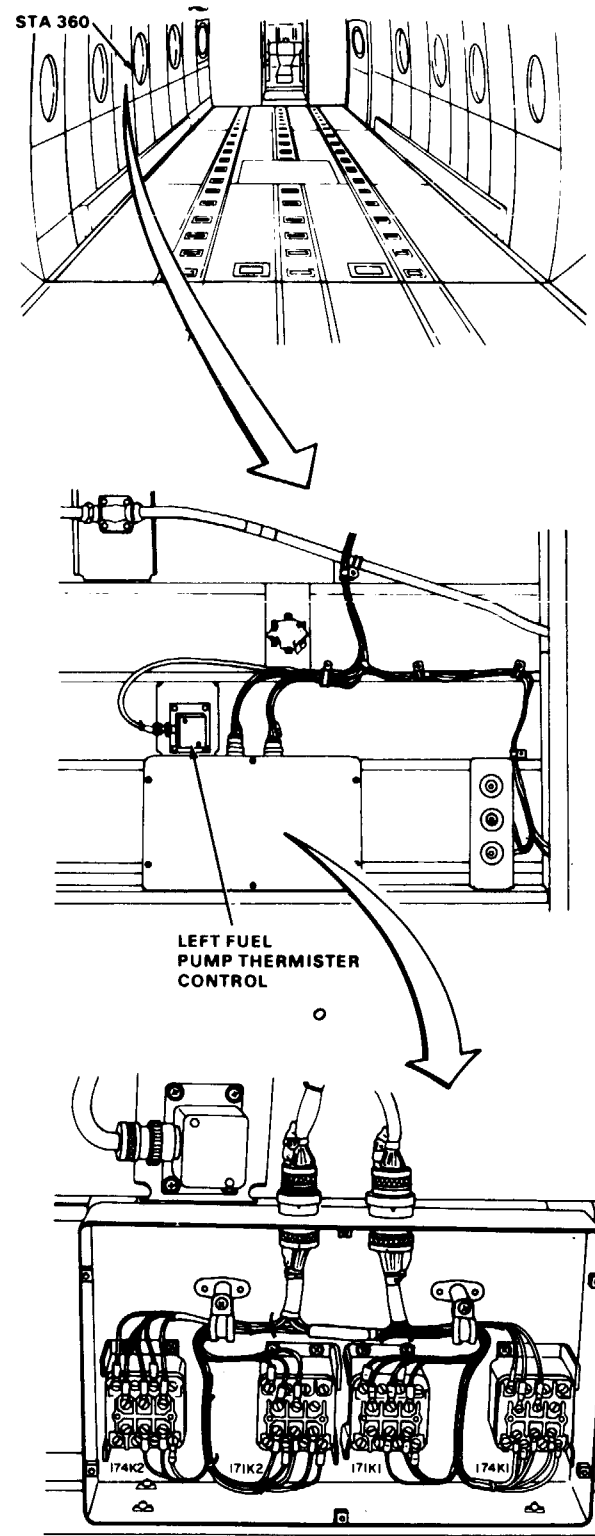
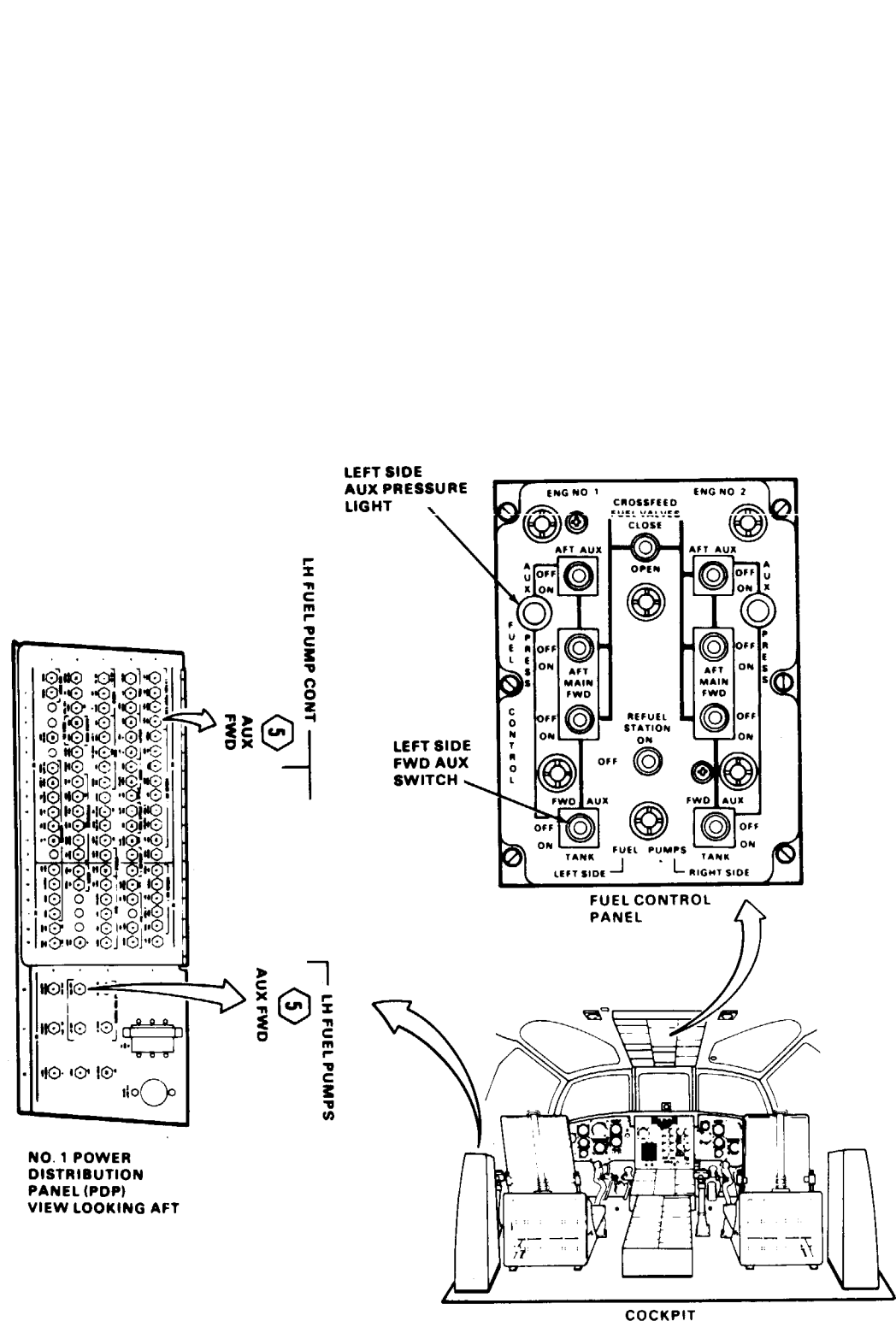

9639

FAULT ISOLATION PROCEDURE

INITIAL SETUP

Applicable Configurations:

All

Tools:

Electrical Repairer's Tool Kit,
NSN 5180-00-323-4915
Multimeter

Materials:

None

Personnel Required:

Aircraft Electrician (2)

References:

TM 55-1520-240-23

Equipment Condition:

TM 55-1520-240-23:

- Battery Connected
- Electrical Power On
- Hydraulic Power Off
- Side Acoustical Blanket Removed Between Sta 320 and 360.
- Right Aft Intertank Access Panel Open

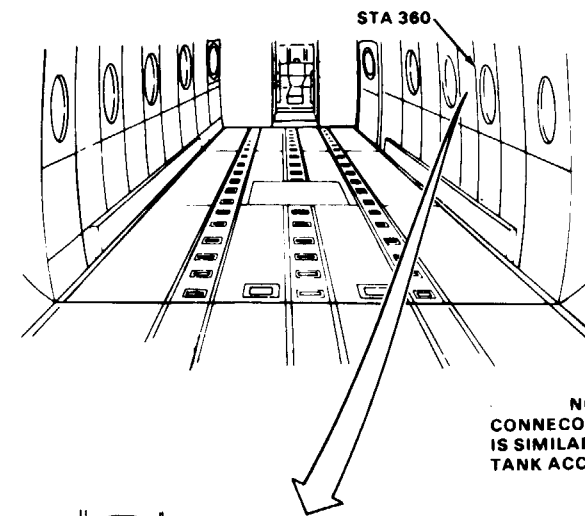
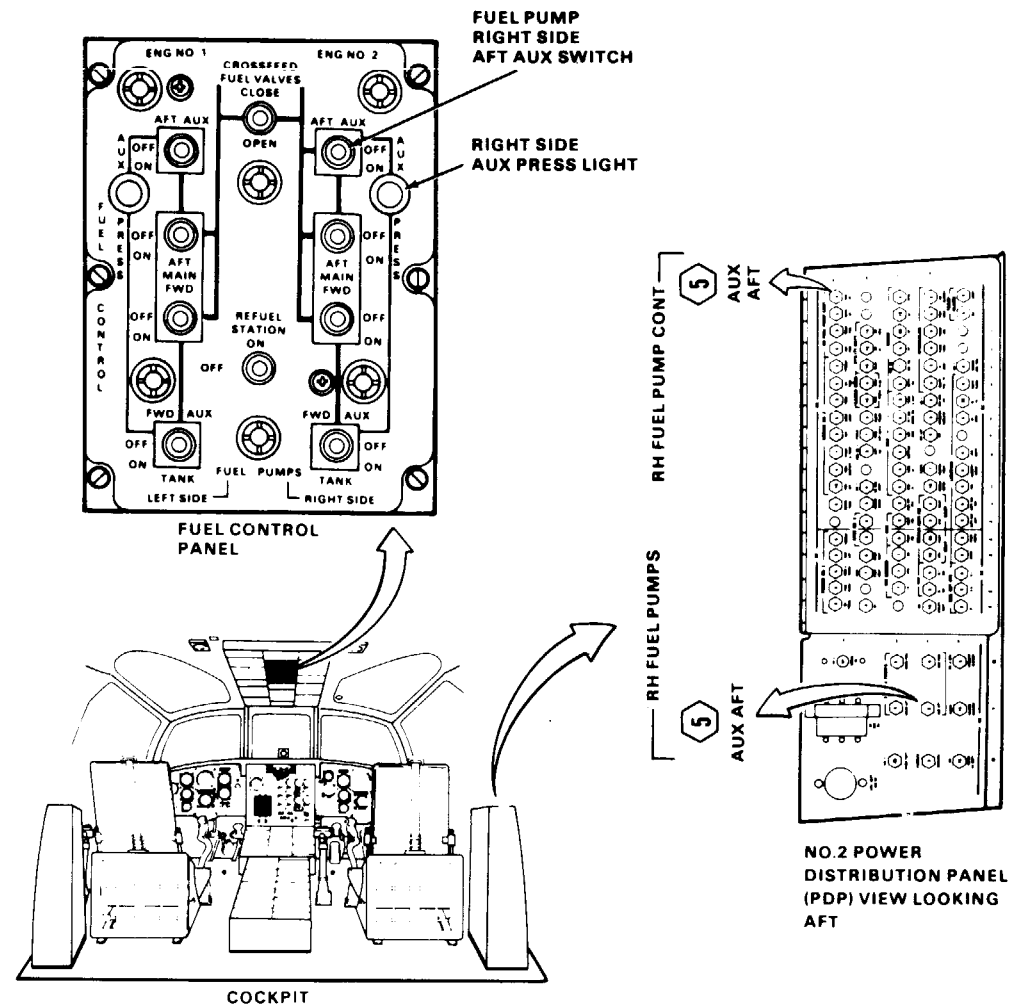
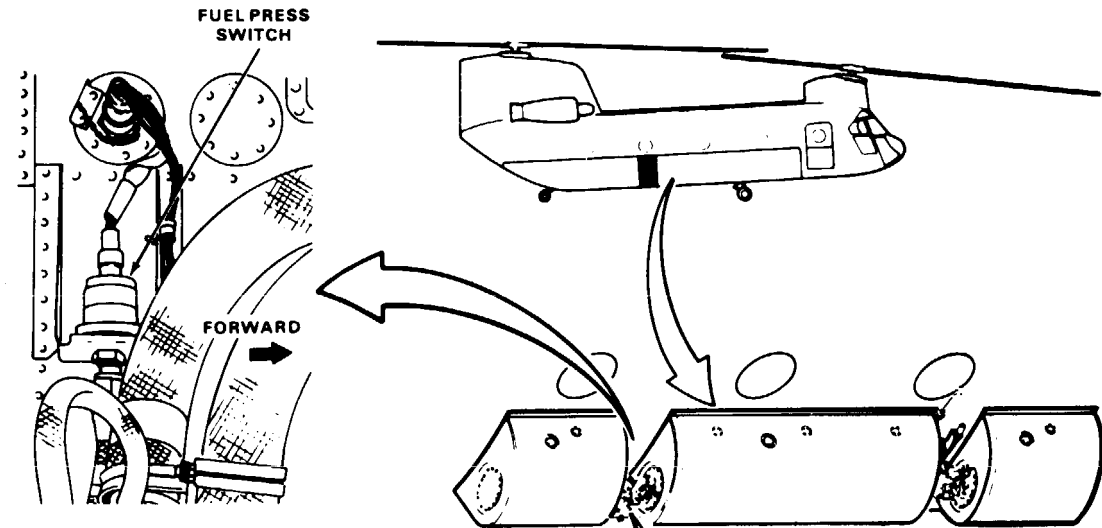

ACCESS DOOR PLUG

NOTE
CONNECTOR INSTALLATION IS SIMILAR FOR ALL TANK ACCESS PANELS.

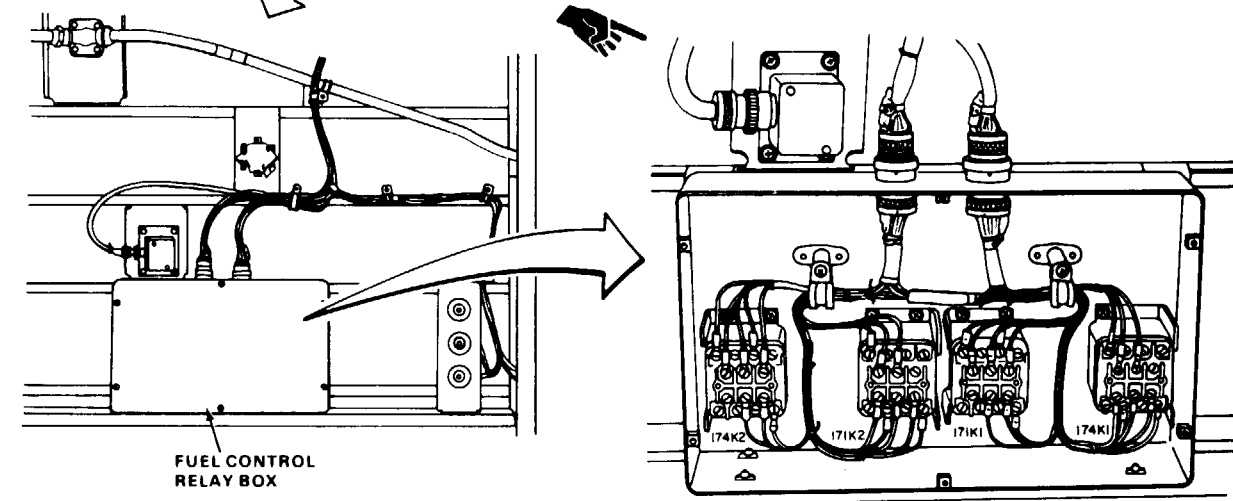

10-2.28 RIGHT SIDE AUX PRESS LIGHT COMES ON WHEN RIGHT SIDE AUX AFT FUEL PUMP SWITCH IS SET TO ON (Continued)

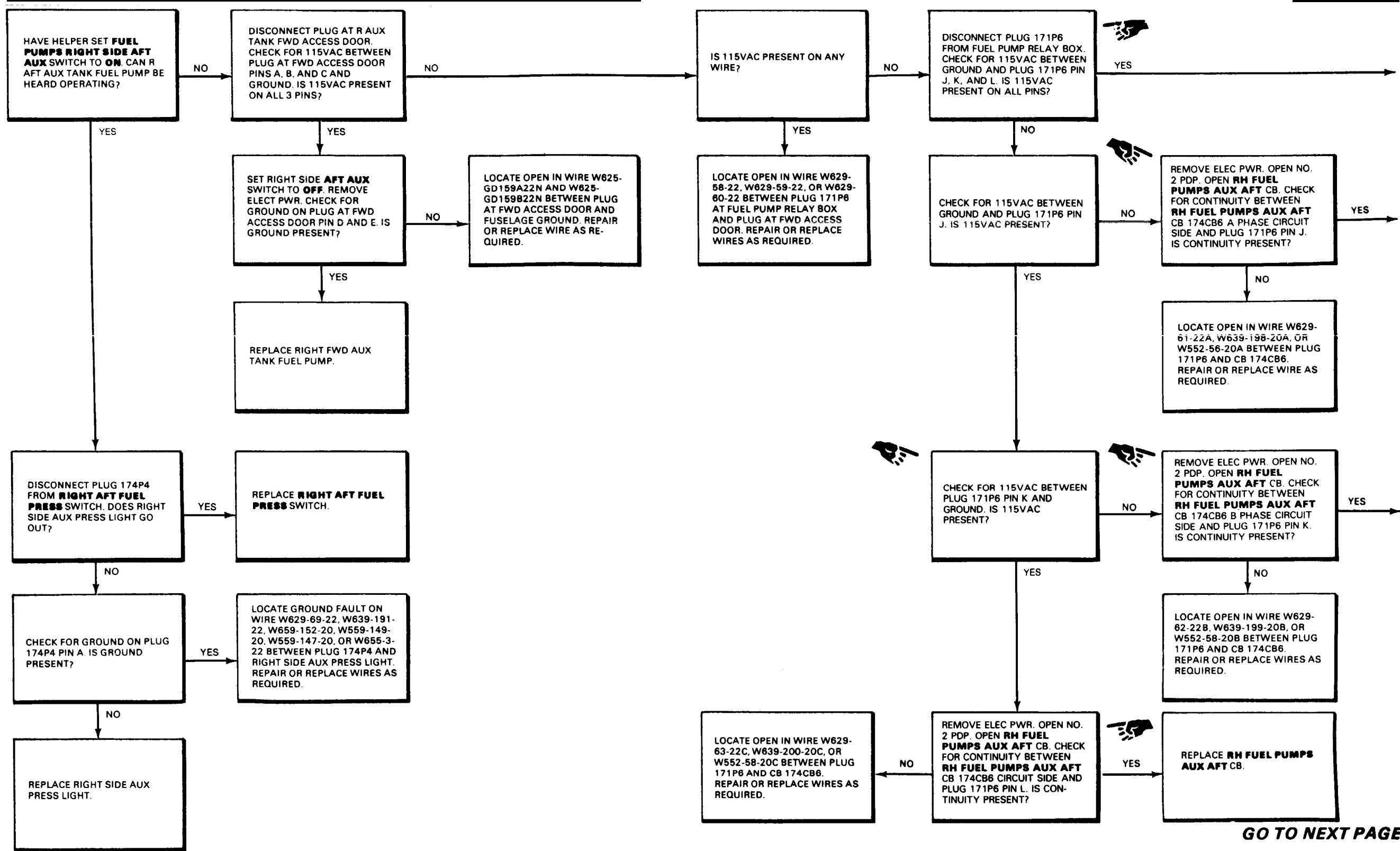

GO TO NEXT PAGE

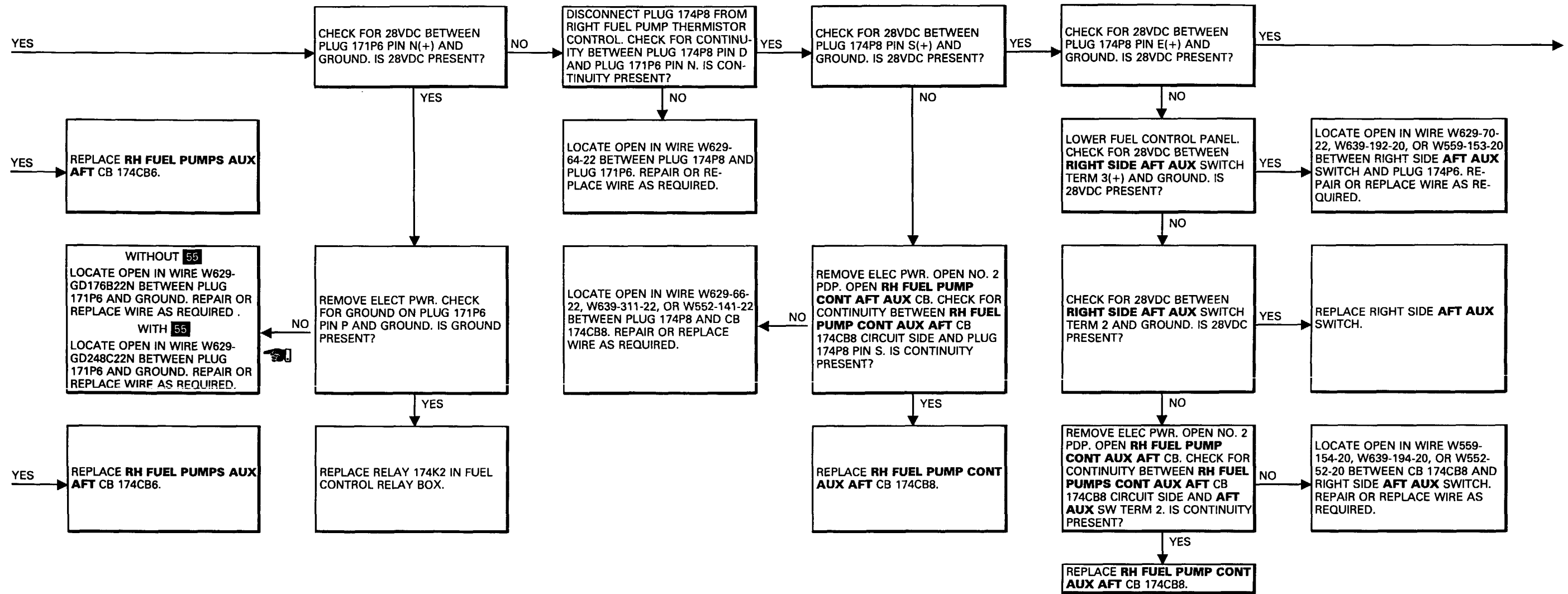

10-2.28 RIGHT SIDE AUX PRESS LIGHT COMES ON WHEN RIGHT SIDE AFT AUX FUEL PUMP SWITCH IS SET TO ON
(Continued)

10-2.28

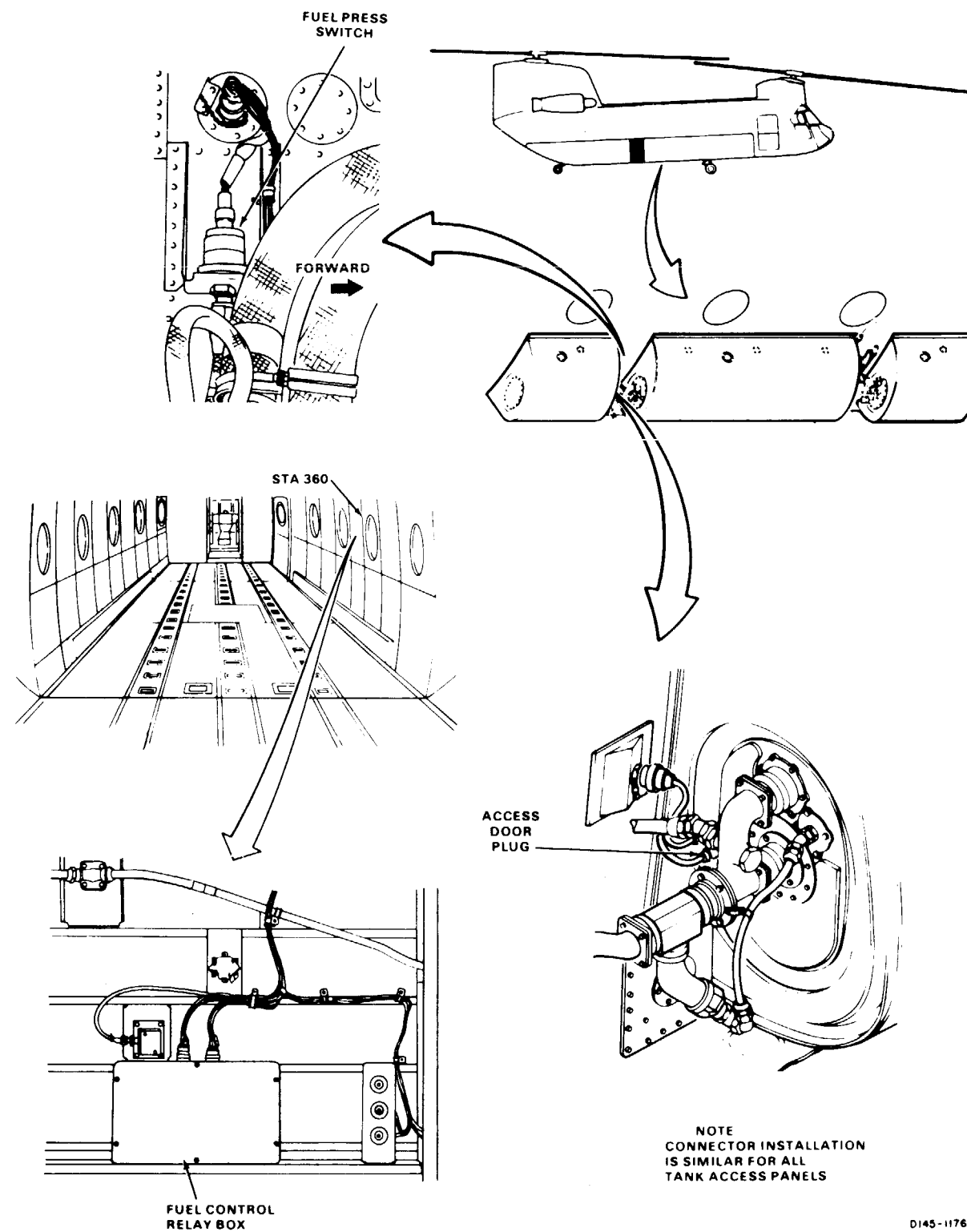
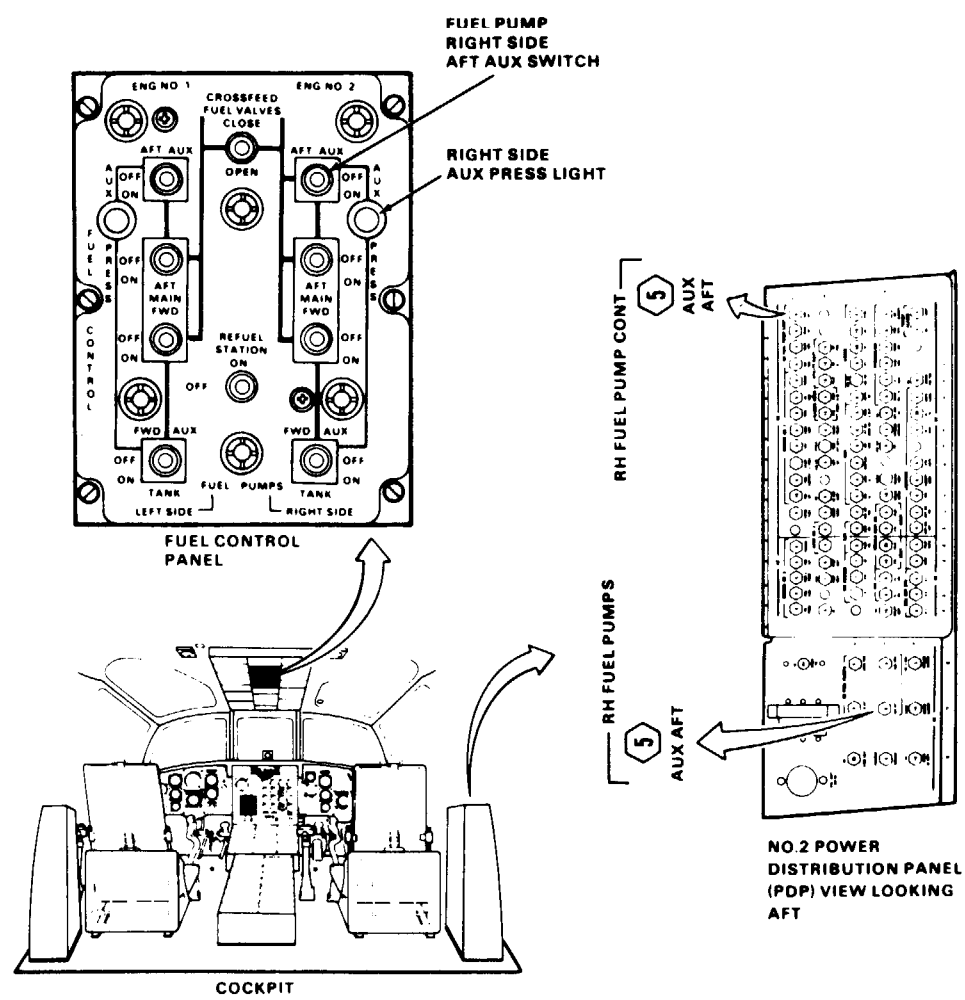

90 X 54

0145-11764-SPA

GO TO NEXT PAGE

10-2.28 RIGHT SIDE AUX PRESS LIGHT DOES NOT COME ON WHEN RIGHT SIDE AUX AFT FUEL PUMP SWITCH IS SET TO ON (Continued)

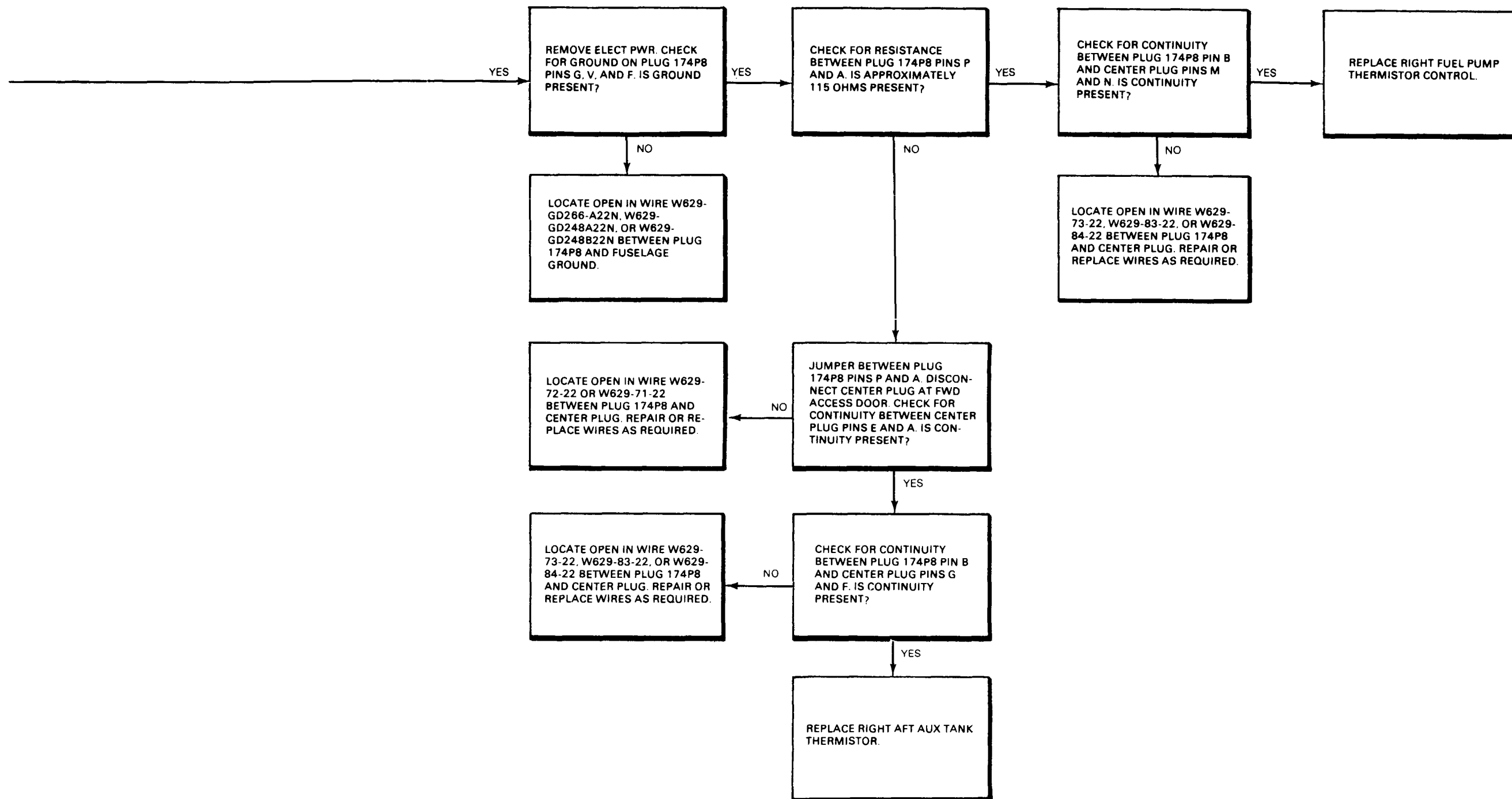

GO TO NEXT PAGE

10-2.28 RIGHT SIDE AUX PRESS LIGHT COMES ON WHEN RIGHT SIDE AFT AUX FUEL PUMP SWITCH IS SET TO ON (Continued)

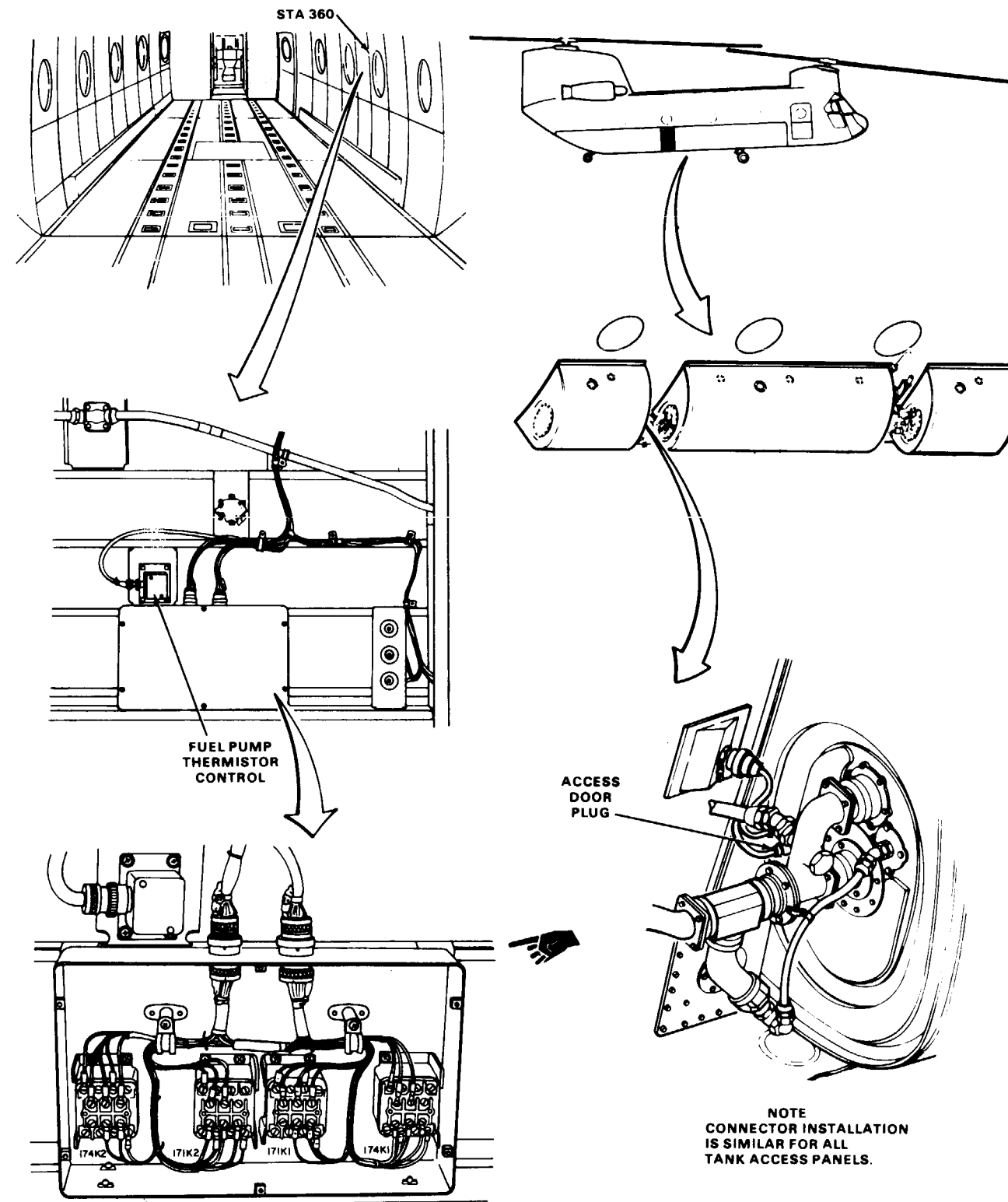
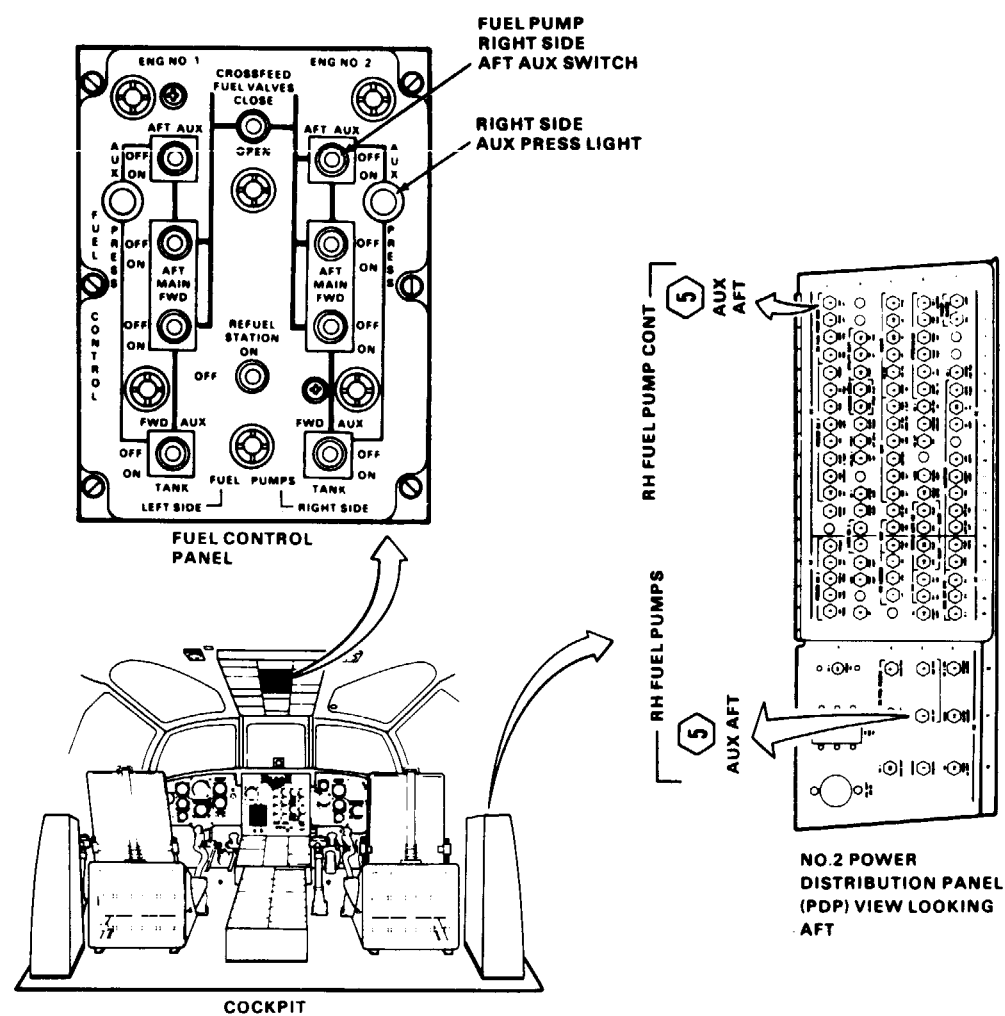

FAULT ISOLATION PROCEDURE

INITIAL SETUP

Applicable Configurations:

All

Tools:

- Electrical Repairer's Tool Kit,
NSN 5180-00-323-4915
- Multimeter

Materials:

None

Personnel Required:

- Aircraft Electrician (2)

References:

TM 55-1520-240-23

Equipment Condition:

- TM 55-1520-240-23:
- Battery Connected
- Electrical Power On
- Hydraulic Power Off
- Side Acoustical Blanket Removed Between Sta 320 and 360
- Right Forward Landing Gear Access Panel Open

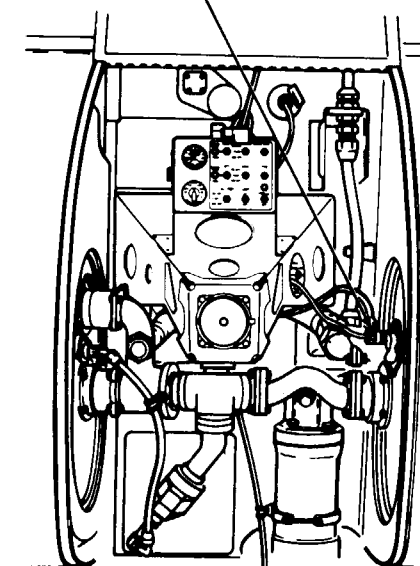
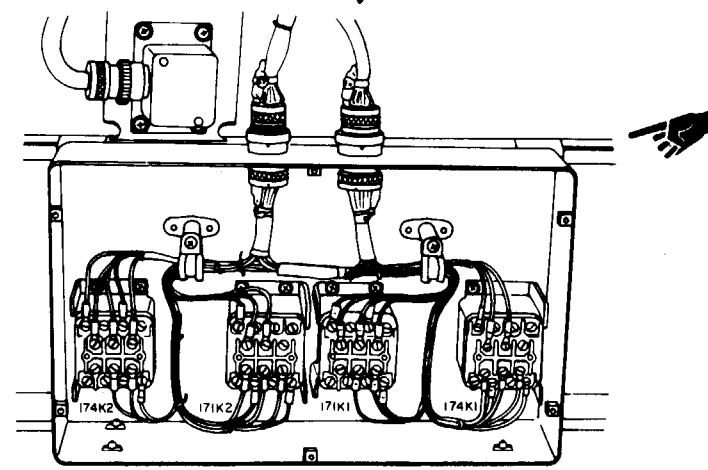
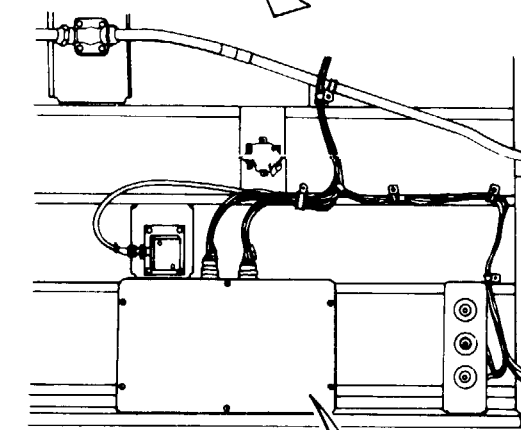
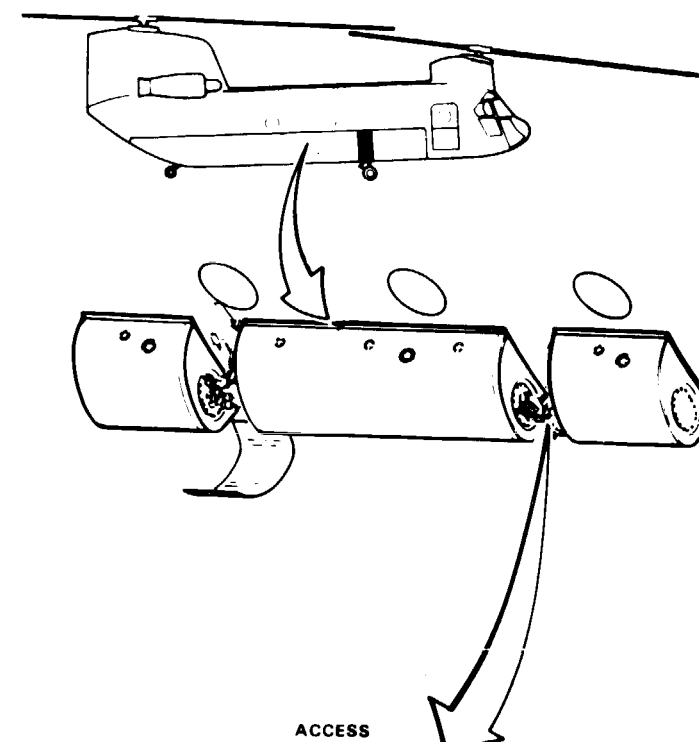
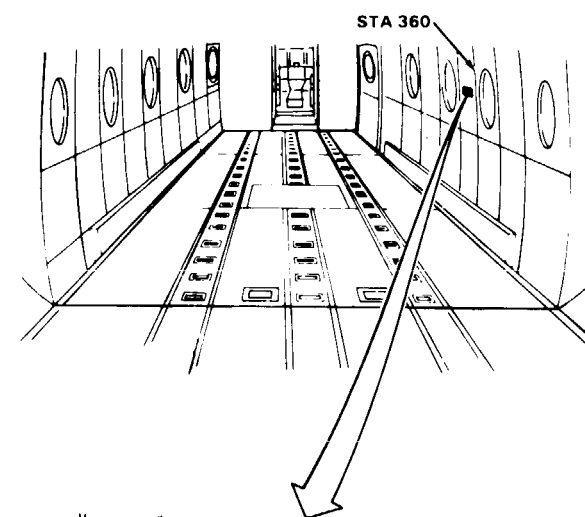
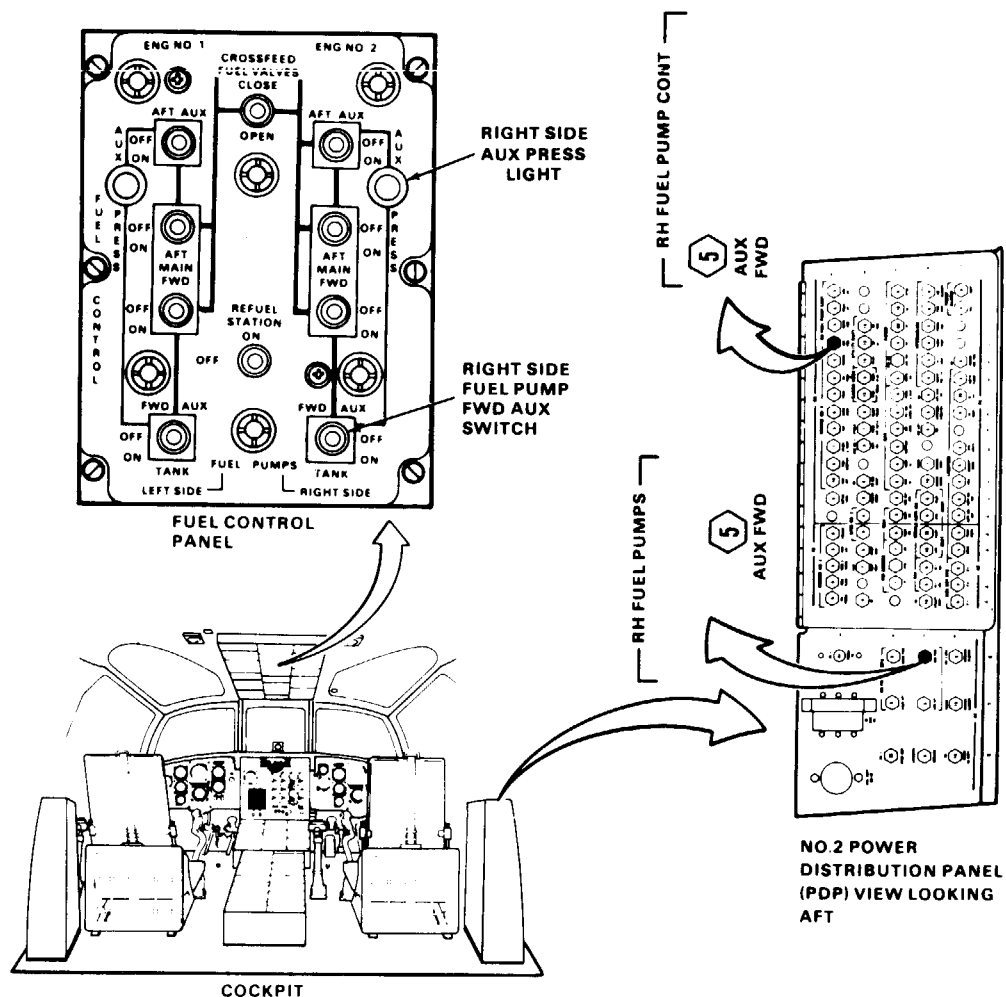

10-2.29 RIGHT SIDE AUX PRESS LIGHT COMES ON WHEN RIGHT SIDE FWD AUX FUEL PUMP SWITCH IS SET TO ON (CONTINUED)

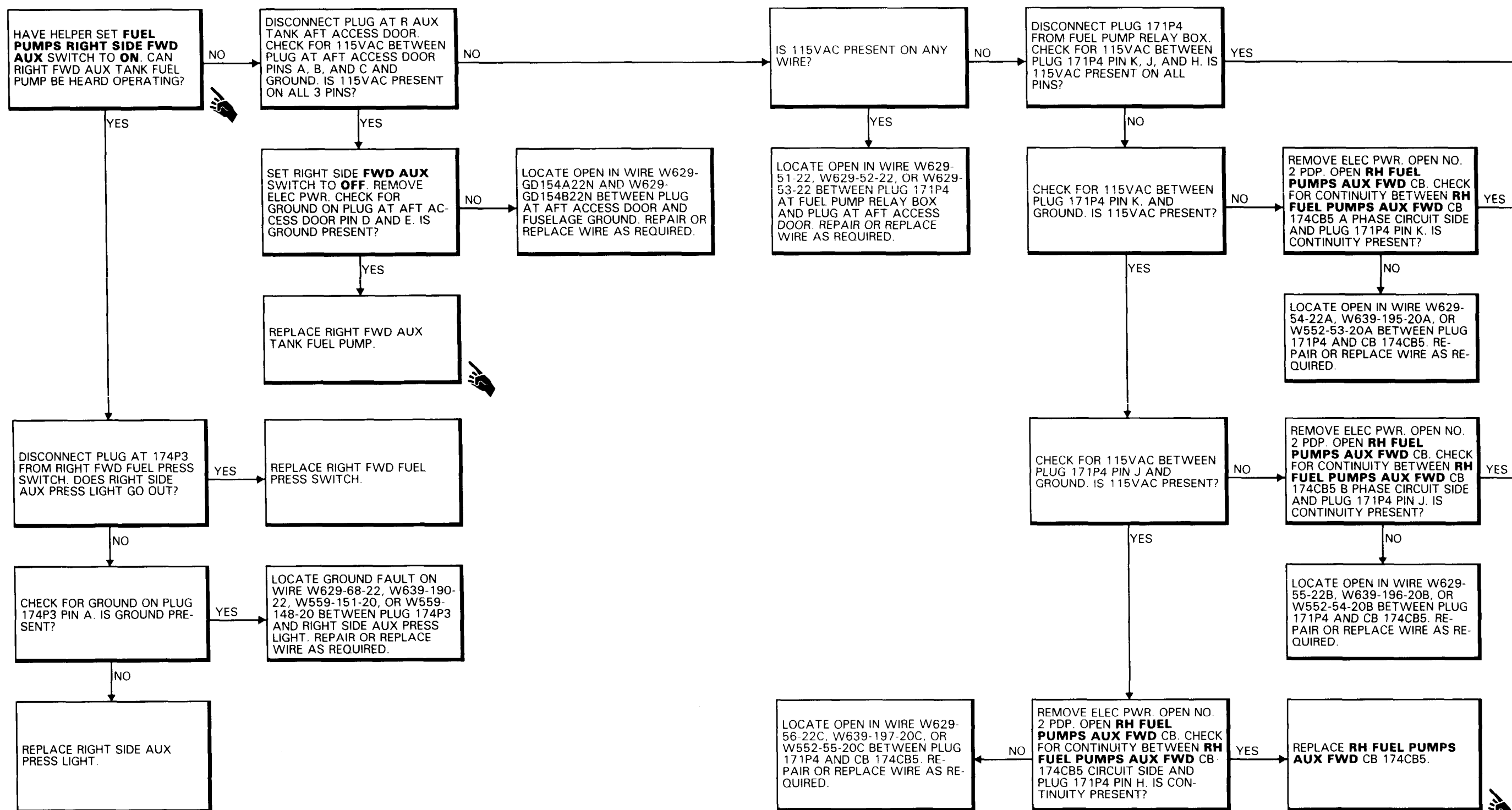

10-2.29 RIGHT SIDE AUX PRESS LIGHT COMES ON WHEN RIGHT SIDE FWD AUX FUEL PUMP SWITCH IS SET TO ON
(Continued)

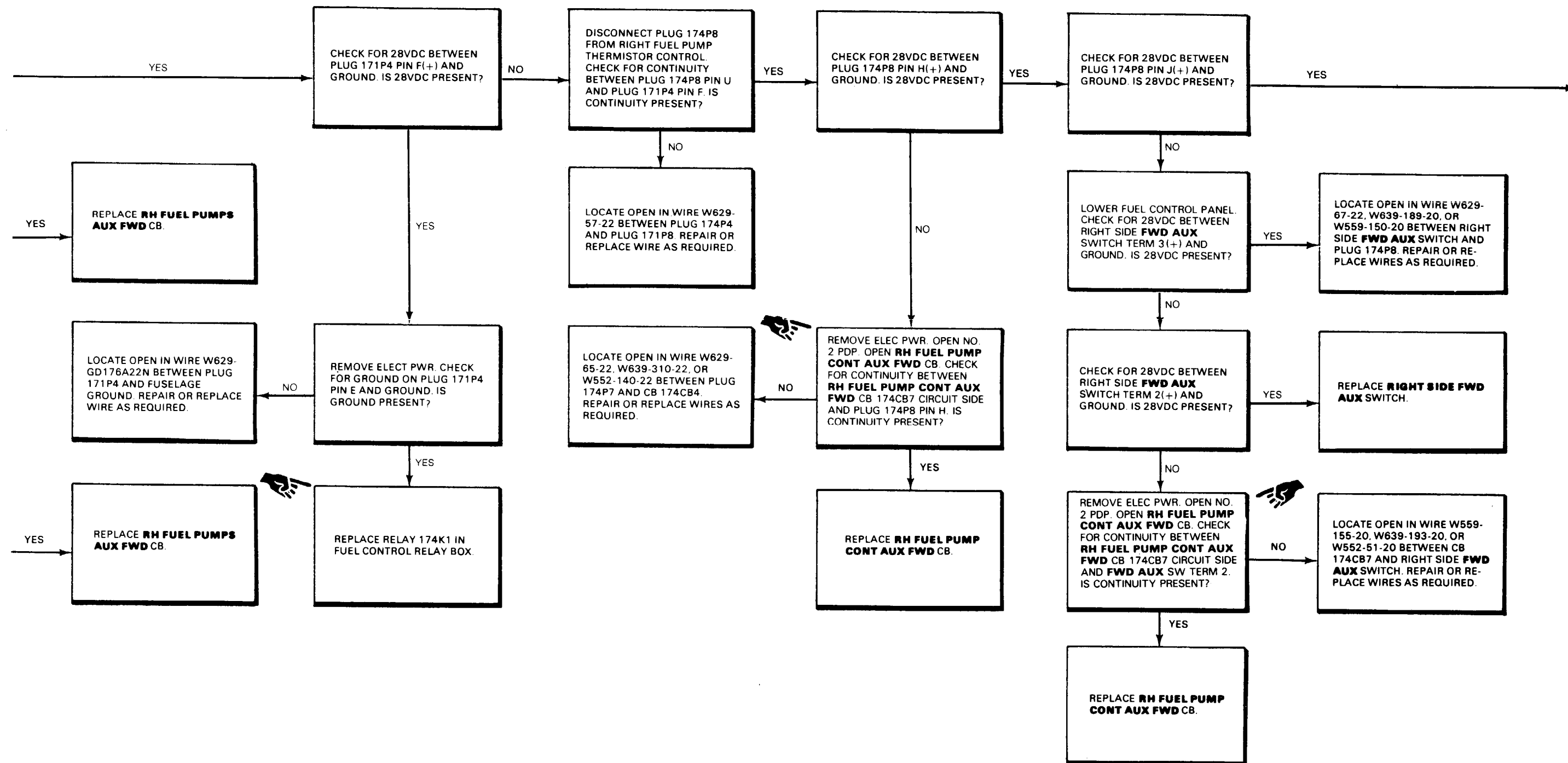

10-2.29 RIGHT SIDE AUX PRESS LIGHT COMES ON WHEN RIGHT SIDE FWD AUX FUEL PUMP SWITCH IS SET TO ON
(Continued)

10-2.29

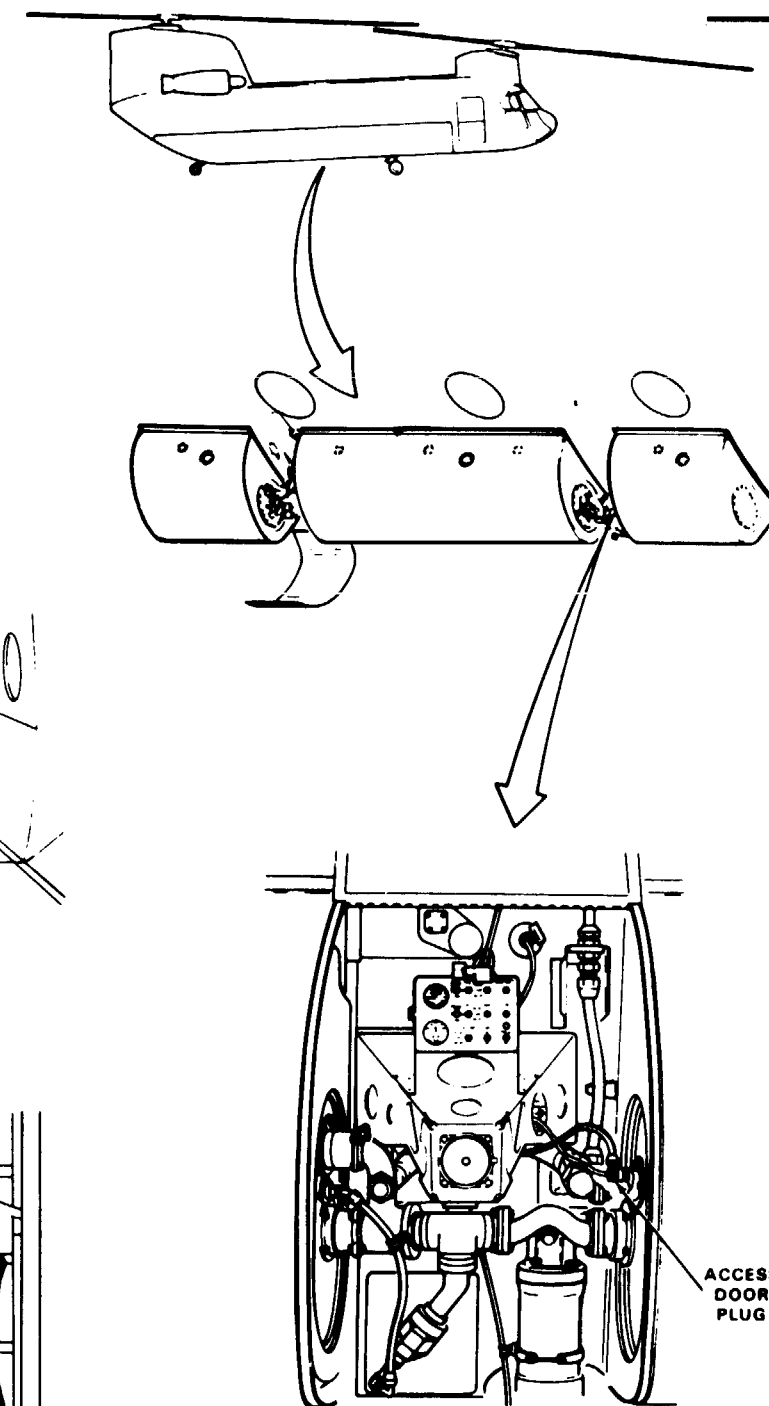
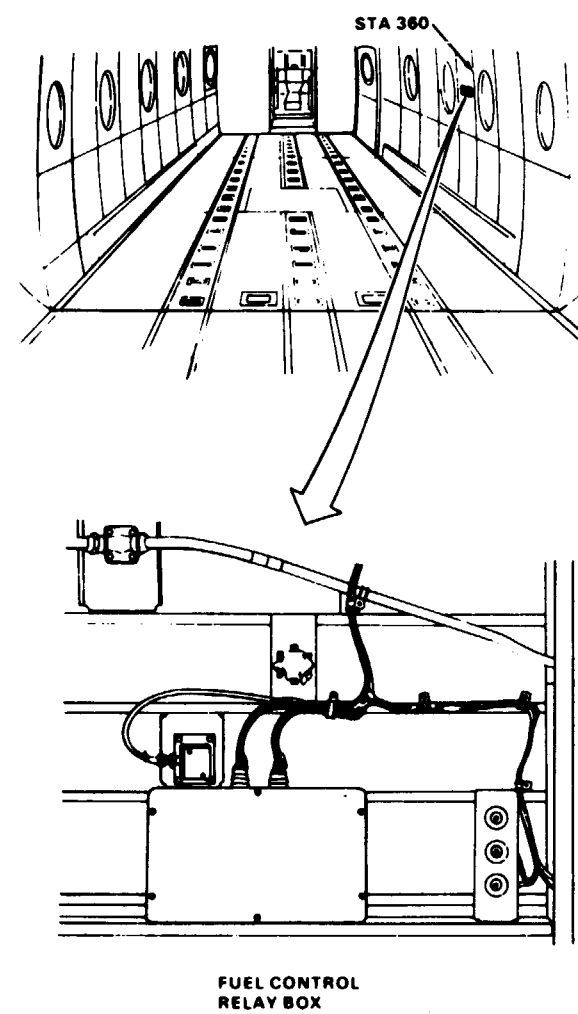
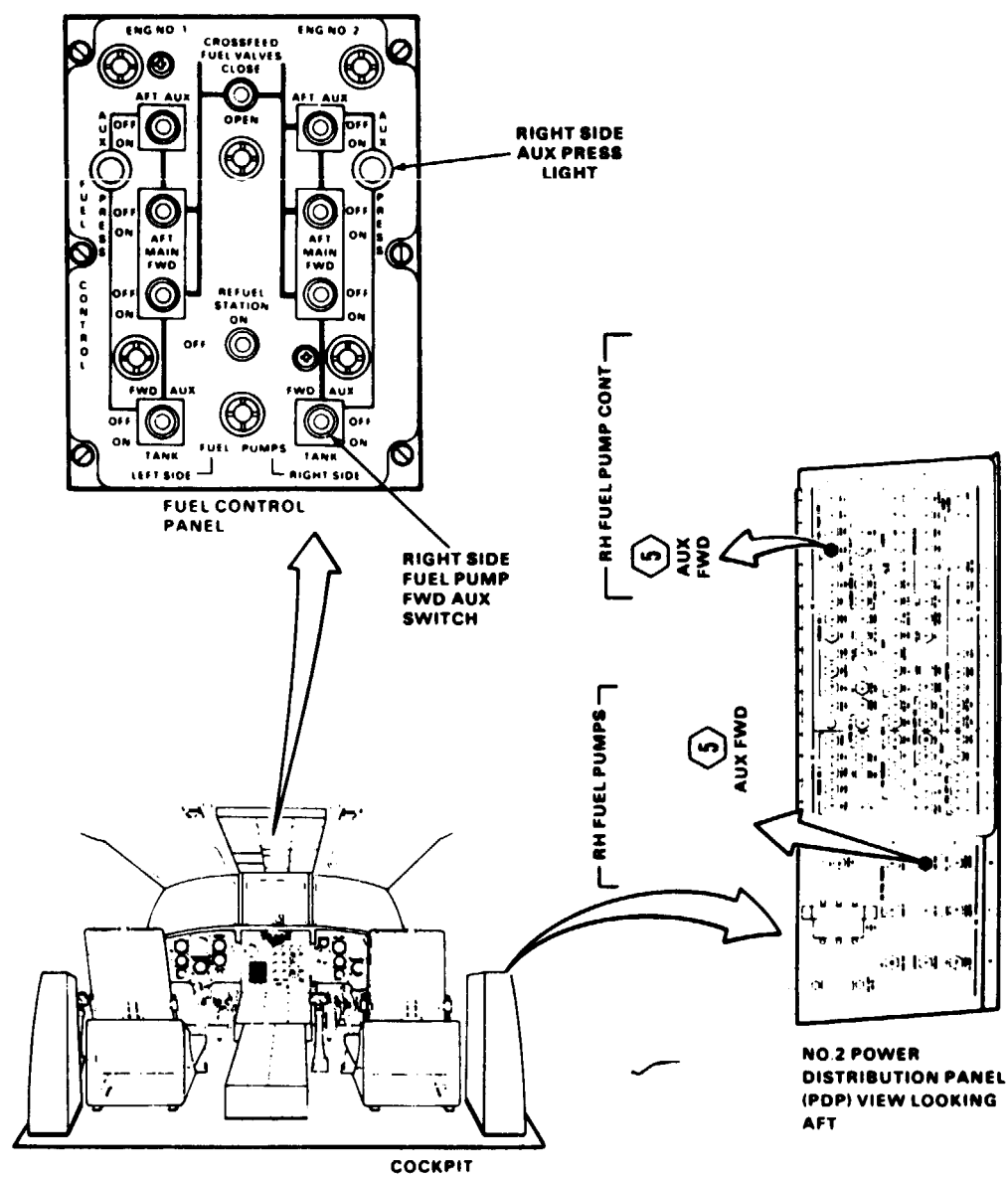

90X54

COCKPIT

NO 2 POWER DISTRIBUTION PANEL (PDP) VIEW LOOKING AFT

FUEL CONTROL RELAY BOX

D145-11767-SPA

GO TO NEXT PAGE

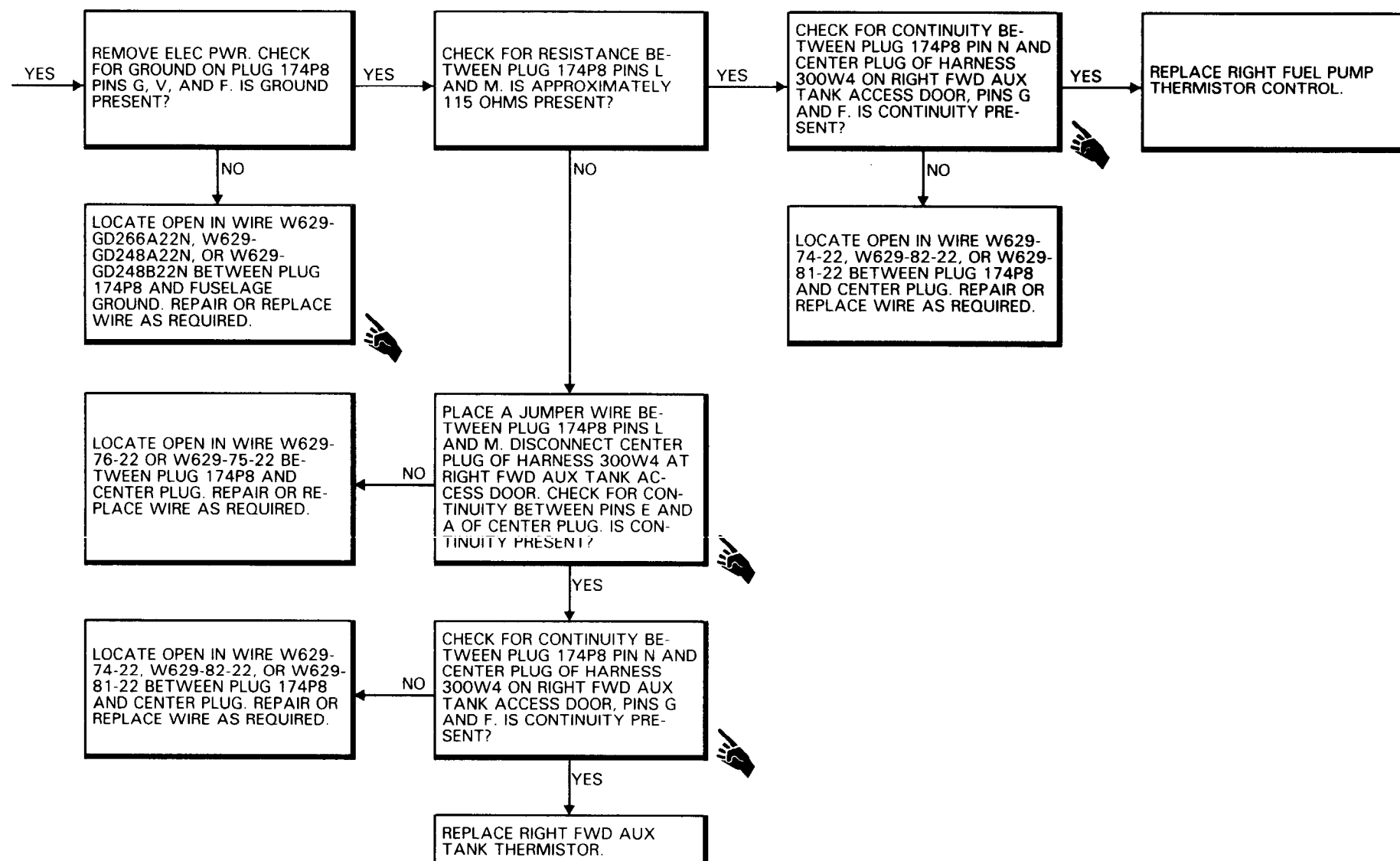

10-2.29 RIGHT SIDE AUX PRESS LIGHT COMES ON WHEN RIGHT SIDE FWD AUX FUEL PUMP SWITCH IS SET TO ON
 (Continued)

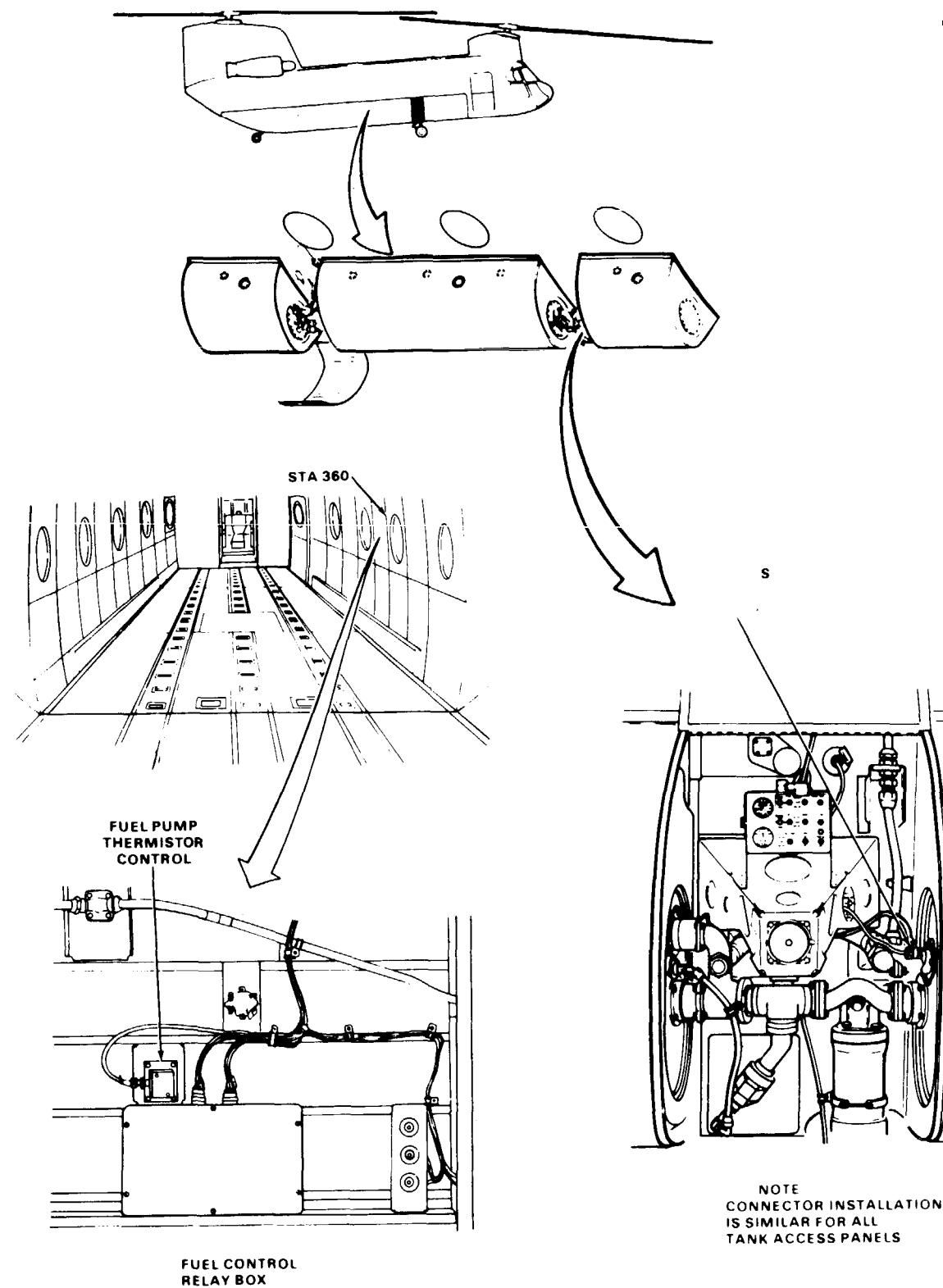
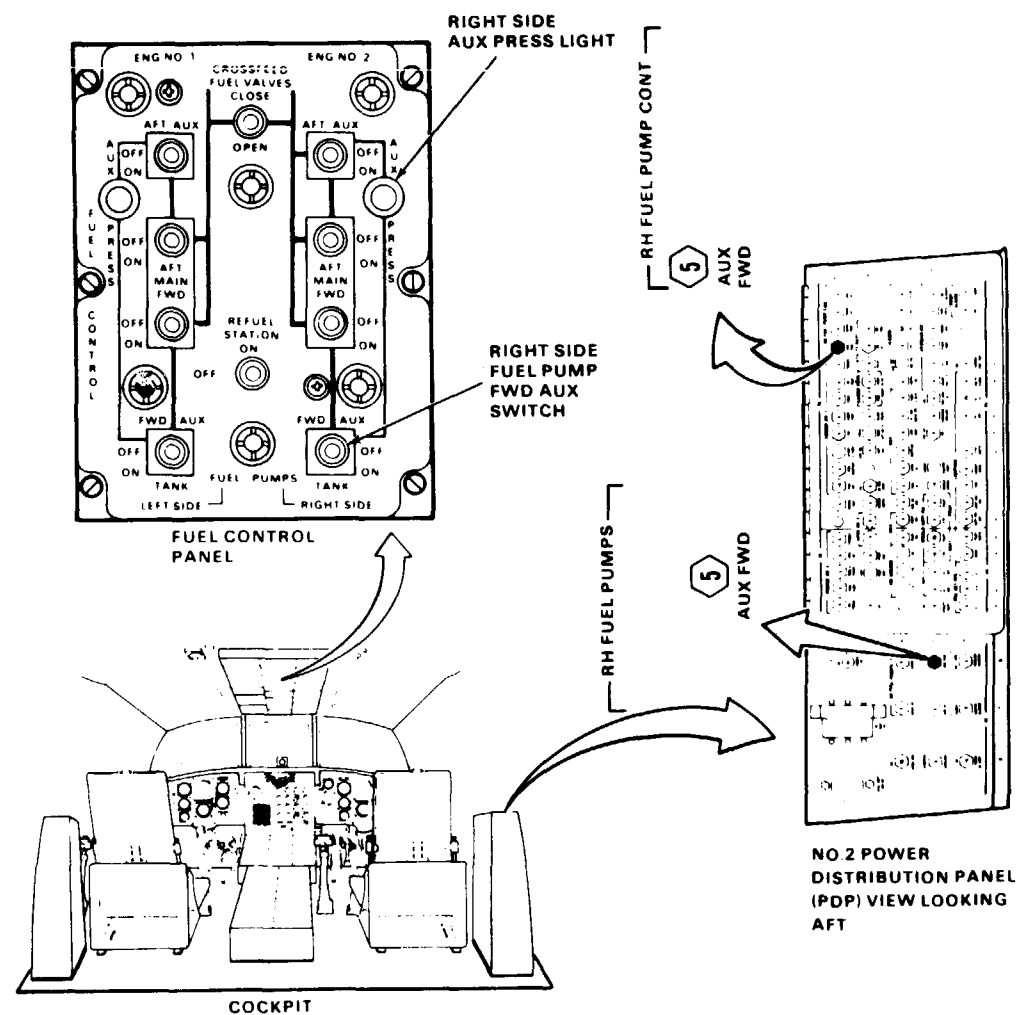

10-3 SINGLE POINT PRESSURE REFUELING SYSTEM

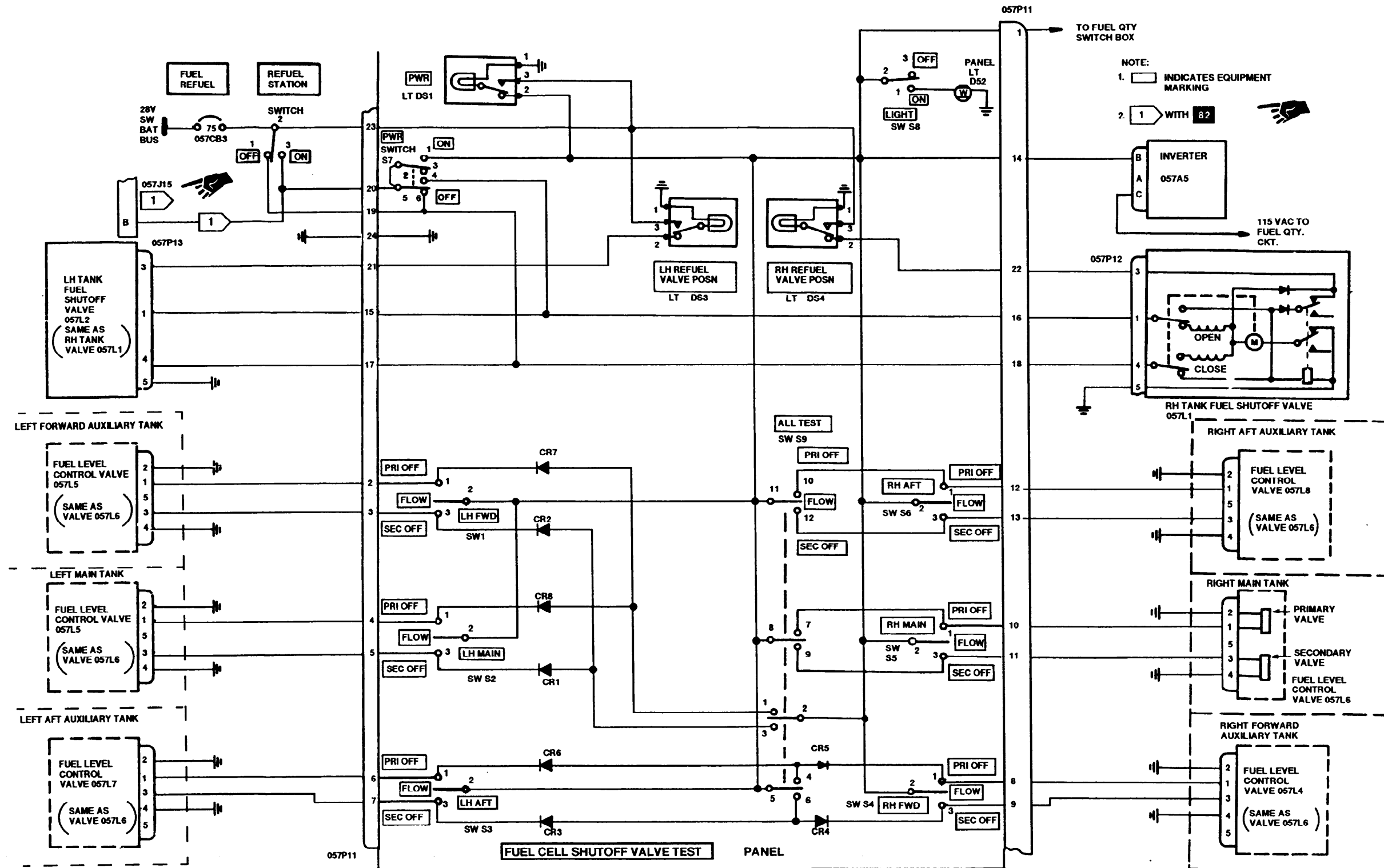

A73203

END OF TASK

10-3.2 SINGLE POINT PRESSURE REFUELING SYSTEM WIRING DIAGRAM

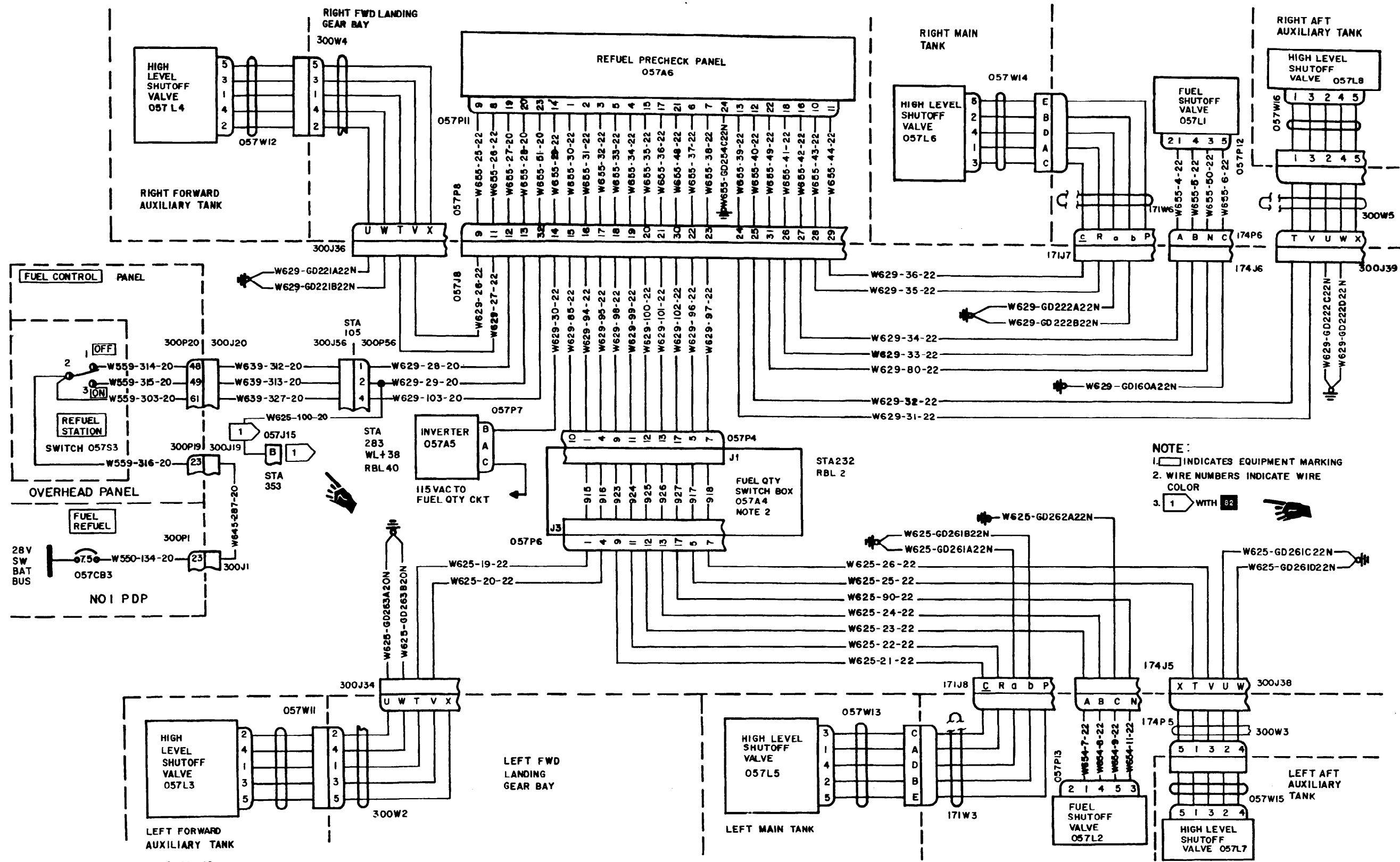

NOTE:

1. [] INDICATES EQUIPMENT MARKING
2. WIRE NUMBERS INDICATE WIRE COLOR
3. 1 WITH 82

057. 100A, 110A, 120A, 130, 140D, 150, 160





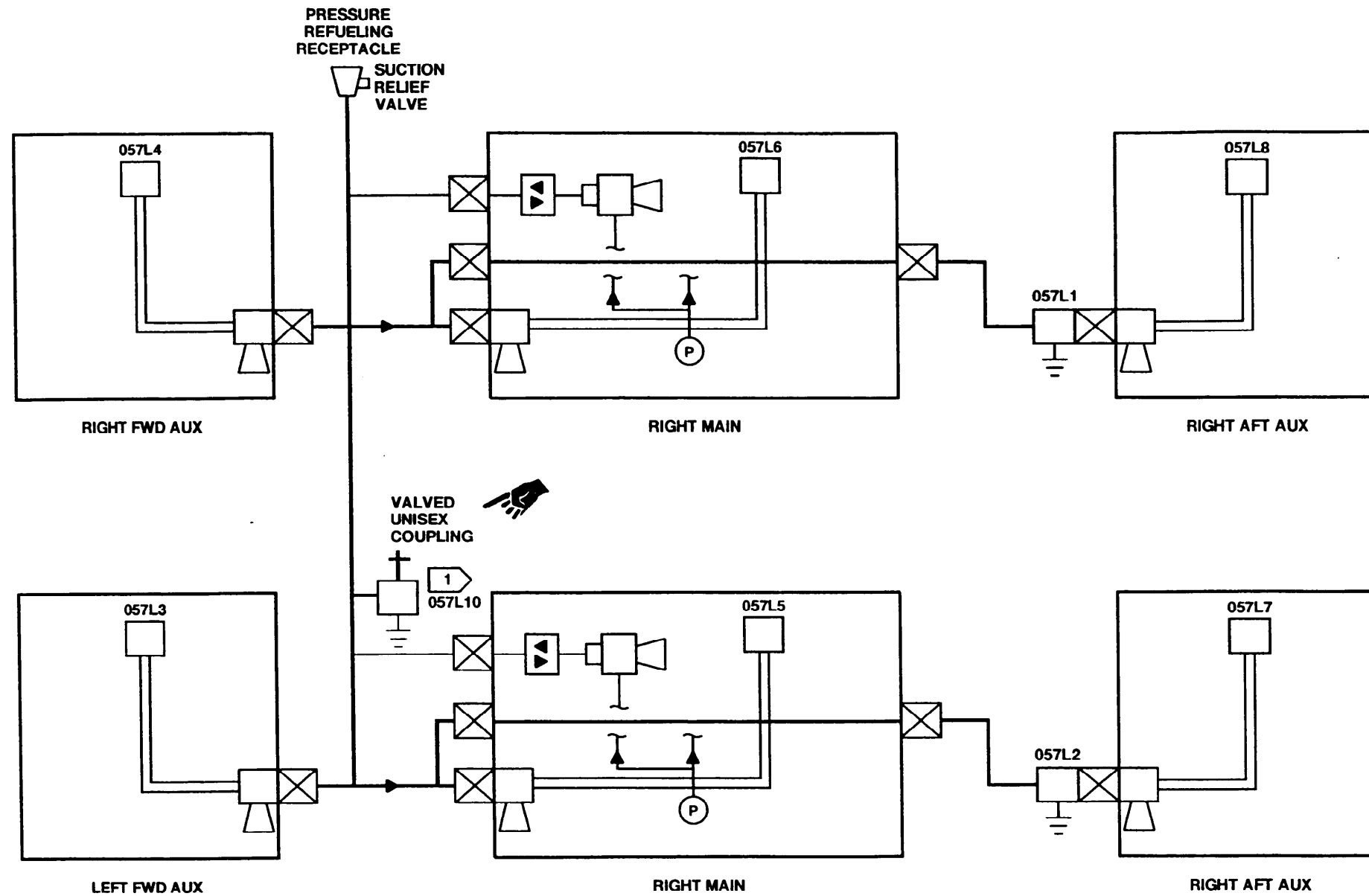



A73204

END OF TASK
Change 22 10-125



NOTE:

1. SYMBOLS

-  BREAKAWAY FITTING
-  JET PUMP (REFUELING MANIFOLD EVACUATION)
-  PRESSURE FUELING SHUTOFF VALVE
-  CHECK VALVE
-  ENGINE FEED BOOST PUMP
-  MOTOR OPERATED SHUTOFF VALVE
-  LEVEL CONTROL PILOT VALVE
-  TWO WAY CHECK VALVE

2.  WITH  

10-3.3 SINGLE POINT PRESSURE REFUELING SYSTEM VISUAL CHECK

INITIAL SETUP

Applicable Configurations:

All

Tools:

Electrical Repairer's Tool Kit,
NSN 5180-00-323-4915

Materials:

None

Personnel Required:

Aircraft Electrician

References:

TM 55-1520-240-23

Equipment Condition:

TM 55-1520-240-23:
Electrical Power Off
Battery Disconnected
Hydraulic Power Off
Forward Right Landing Gear Access Panel Open

TASK	RESULT
1. Check REFUEL STATION switch (1).	If switch (1) is loose or damaged, tighten or replace it as required.
2. Check pre-check panel (2).	If panel (2) is loose or damaged, tighten, repair, or replace it as required.
3. Check light (3).	If light (3) is loose or damaged, tighten or replace it as required.
4. Check three lights (4).	If any light (4) is damaged, repair or replace it as required.
5. Check nine switches (5).	If any switch (5) is loose or damaged, tighten or replace as required.
6. Check fuel quantity indicator (6).	H indicator (6) is loose or damaged, tighten or replace it as required.
7. Check fuel quantity selector switch (7).	If switch (7) is loose or damaged, tighten or replace it as required.
8. Check inverter (8).	If inverter (8) is loose or damaged, tighten or replace it as required.
9. On aircraft with 68, check installation of vacuum relief valve (9), security of hose (10) at clamps (11), and connection (12) on refueling adapter (13).	If components are loose or damaged, tighten or replace as required.

FOLLOW-ON MAINTENANCE:

None

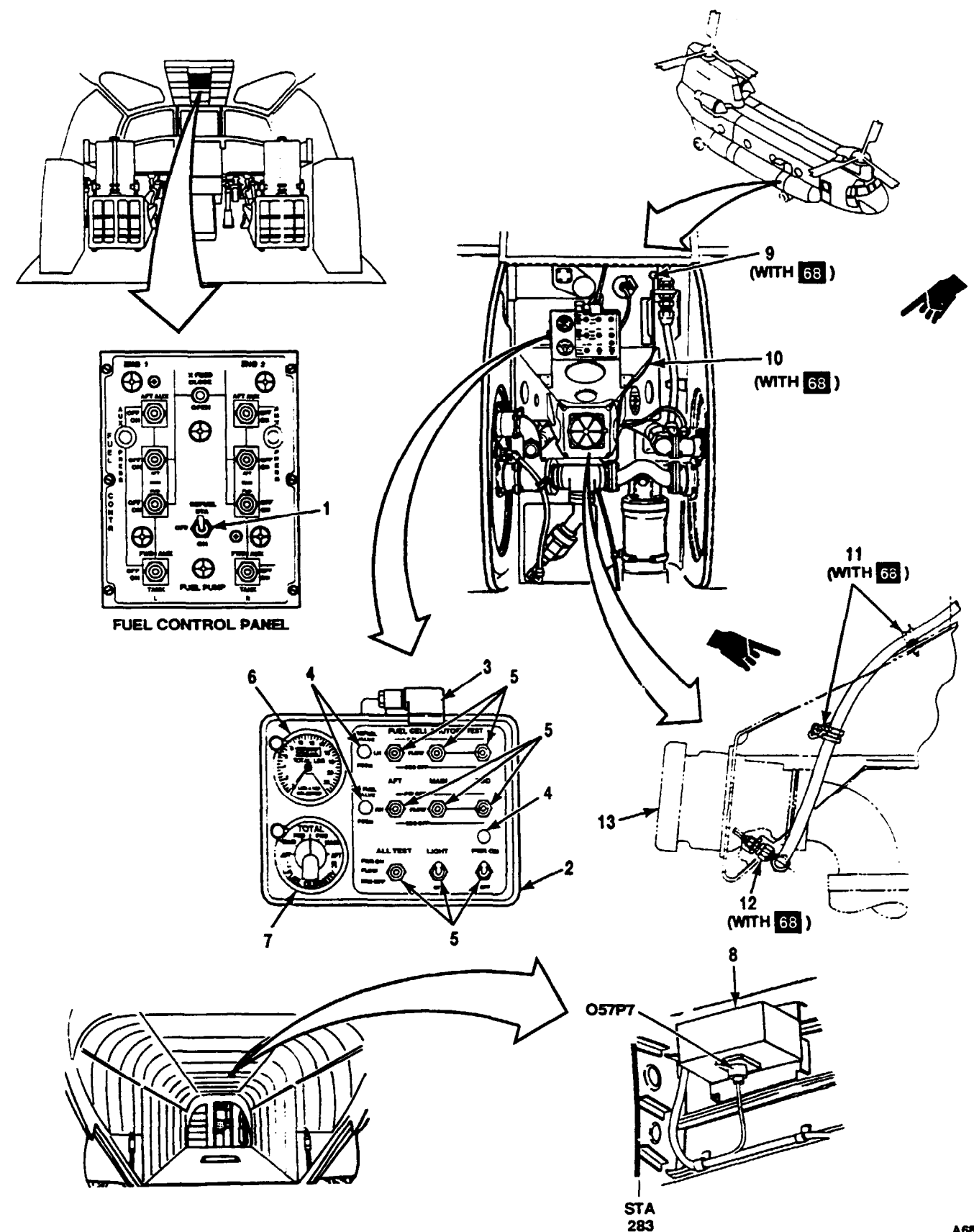

INITIAL SETUP

Applicable Configurations:

All

Tools:

None

Materials:

None

Personnel Required:

Medium Helicopter Repairer

References:

TM 55-1520-240-23

Equipment Condition:

TM 55-1520-240-23:

Electrical Power Off

Battery Connected

Hydraulic Power Off

Visual Check of Single Point Pressure Refueling System Performed (Task 10-3.3)

TASK

RESULT

NOTE

A small amount of fuel will continue to flow through the open primary and secondary valves when the refueling valve is dosed.

8. Perform single point refueling of all tanks or individual tank as required. Refer to TM 55-1520-240-23.

If fuel does not stop flowing within 4 seconds with ALL TEST switch (11) at PRI OFF, stop refueling and go to Task 10-3.12.

If fuel does not stop flowing within 4 seconds with ALL TEST switch (11) at SEC OFF, stop refueling and go to Task 10-3.13.

If during initial single tank refueling procedures, fuel begins flowing before tank is selected, stop refueling and go to Task 10-3.12 or 10-3.13.

If fuel does not flow in one or more tanks during single point refueling, go to Task 10-3.14.

On aircraft with 68, if fuel leaks from vacuum relief valve (12), remove and clean valve. Refer to TM 55-1520-240-23, Task 10-119.

On aircraft with 68, if fuel leaks around nipple or fitting (13) to vacuum relief line, remove hardware and repair or replace components as required. Refer to TM 55-1520-240-23, Task 10-119.

TASK

RESULT

- | | |
|---|--|
| <ol style="list-style-type: none"> 1. Make sure FUEL REFUEL circuit breaker (1) is closed. 2. Set REFUEL STATION switch (2) to ON. 3. Make sure LH REFUEL VALVE POSN and RH REFUEL VALVE POSN lights (3 and 4). 4. Press and release LH REFUEL VALVE POSN and RH REFUEL VALVE POSN lights (3 and 4). 5. Set PWR switch (5) to ON. 6. Set LIGHT switch (7) to ON. 7. Turn FUEL QTY SEL switch (9) through its positions. | <p>If circuit breaker (1) is open, dose it. If it opens again, go to Task 10-3.5.</p> <p>Both lights (3 and 4) shall be out. If either light is on, go to Task 10-3.6.</p> <p>Both lights (3 and 4) shall momentarily come on. If either light does not come on, go to Task 10-3.7.</p> <p>Light (6) shall come on. LH REFUEL VALVE POSN and RH REFUEL VALVE POSN lights (3 and 4) shall come on and go out. If light (6) does not come on, go to Task 10-3.7. If either (3 or 4) does not come on, go to Task 10-3.8. If either light comes on and stays on, go to Task 10-3.9.</p> <p>Light (8) shall come on. If it does not, go to Task 10-3.10.</p> <p>Pointer on indicator (10) shall indicate fuel level in tank selected. If pointer does not move for any switch position, go to Task 8-13.18. If pointer indicates fuel amount for all but one position, go to Task 8-13.19.</p> |
|---|--|

FOLLOW-ON MAINTENANCE:

TM 55-1520-240-23:

Battery disconnected.

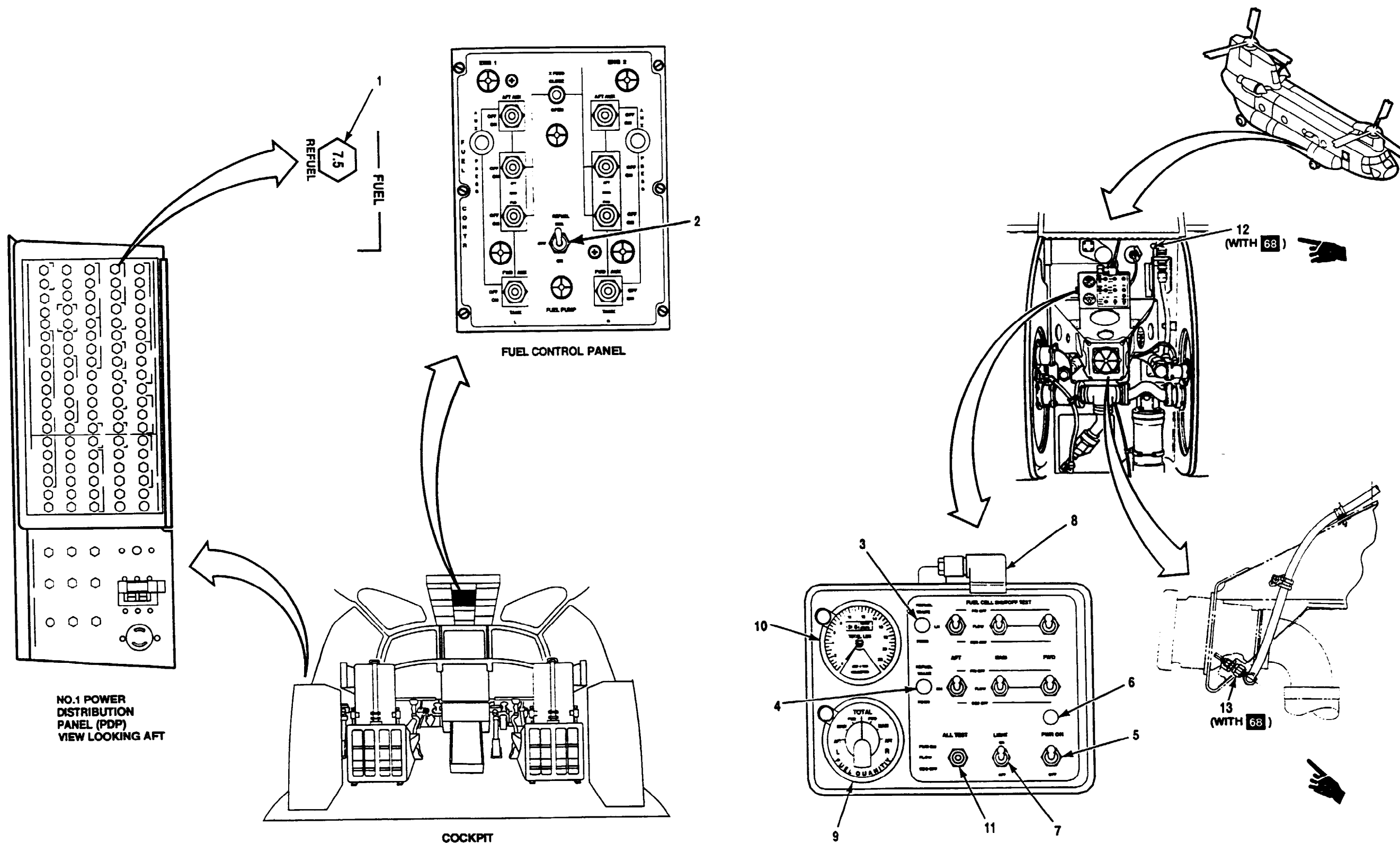

A51213

FAULT ISOLATION PROCEDURE

INITIAL SETUP

Applicable Configurations:

All

Tools:

Electrical Repairer's Tool Kit,
NSN 5180-00-323-4915
Multimeter

Materials:

None

Personnel Required:

Medium Helicopter Repairer
Aircraft Electrician (2)

References:

TM 55-1520-240-23

Equipment Condition:

TM 55-1520-240-23:
Battery Disconnected
Electrical Power Off
Hydraulic Power Off

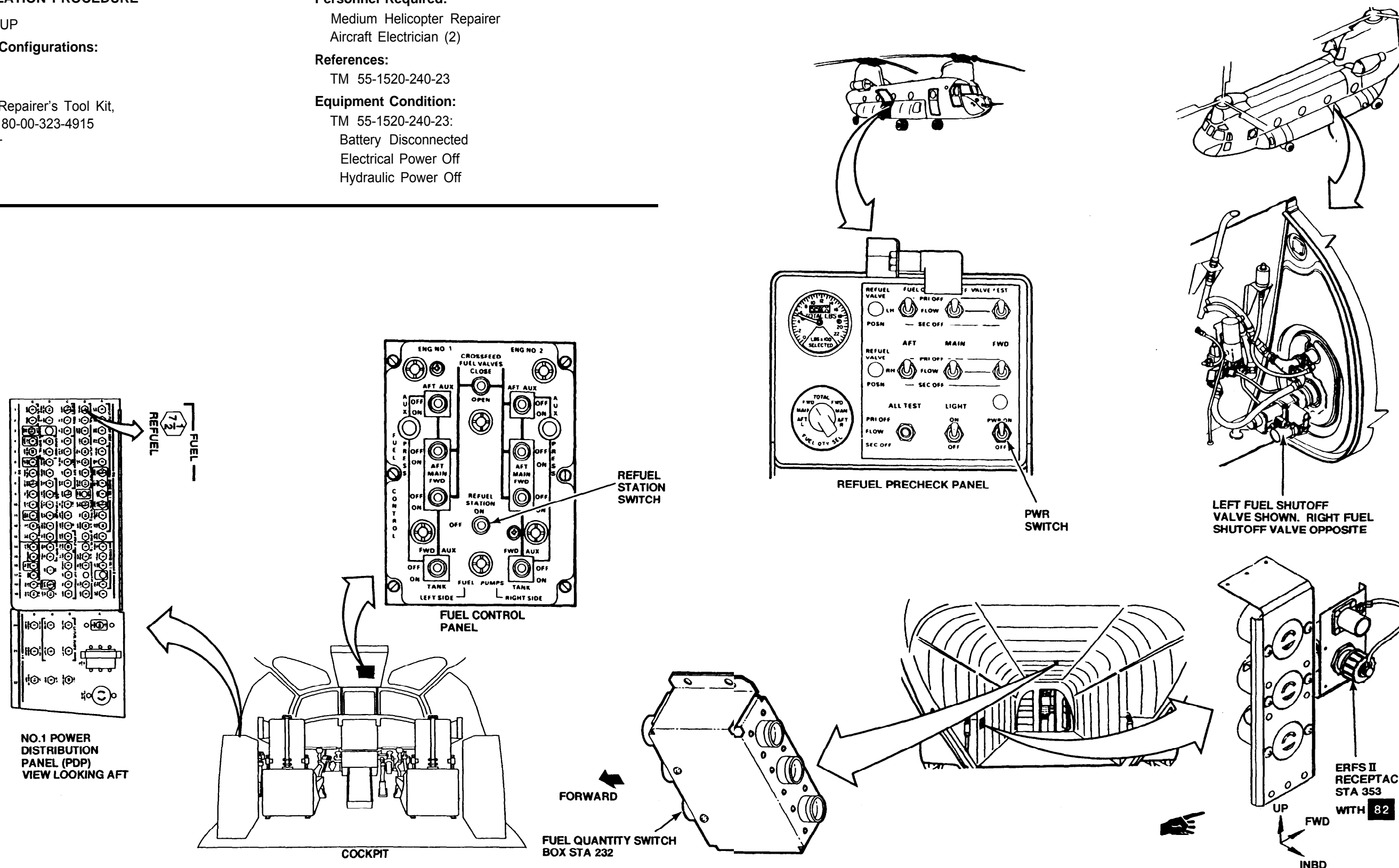

A73206

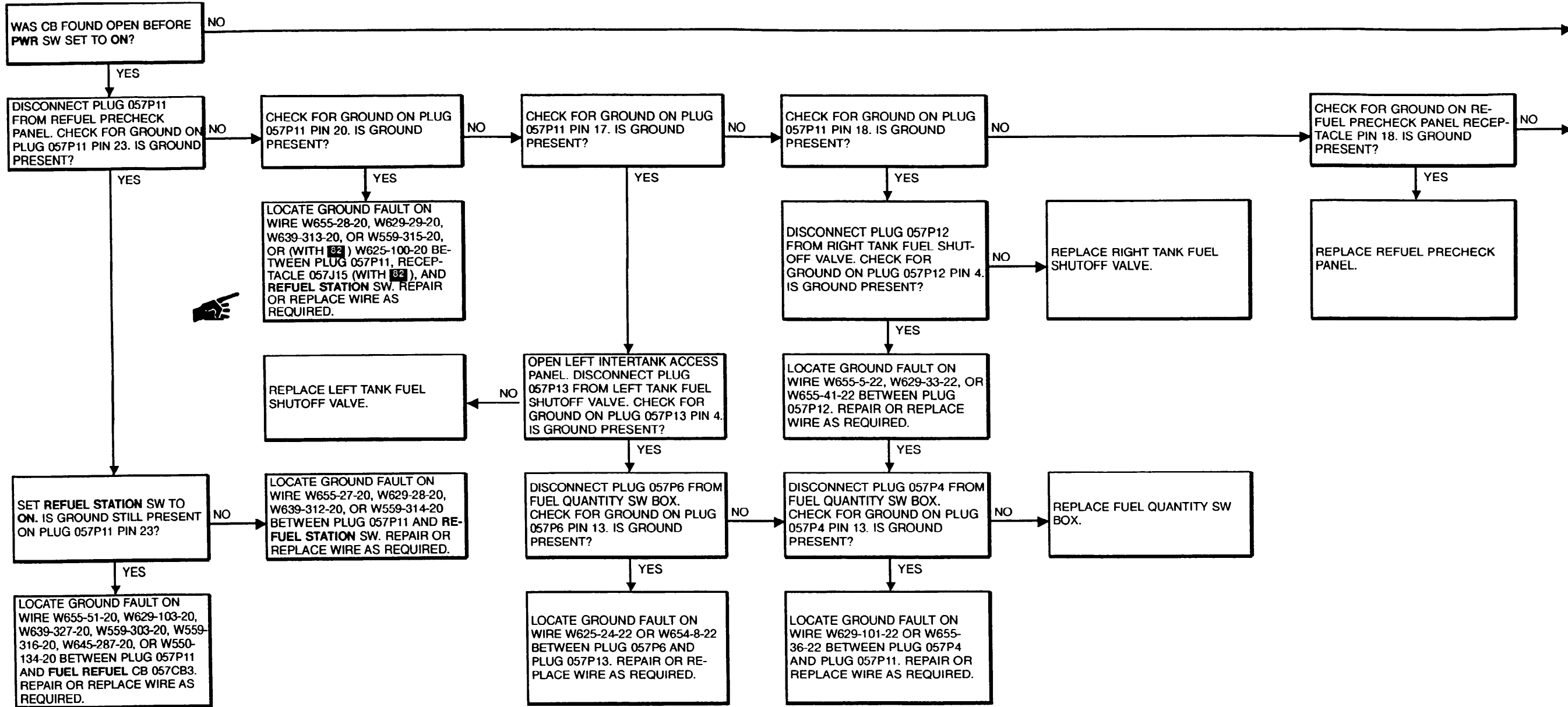

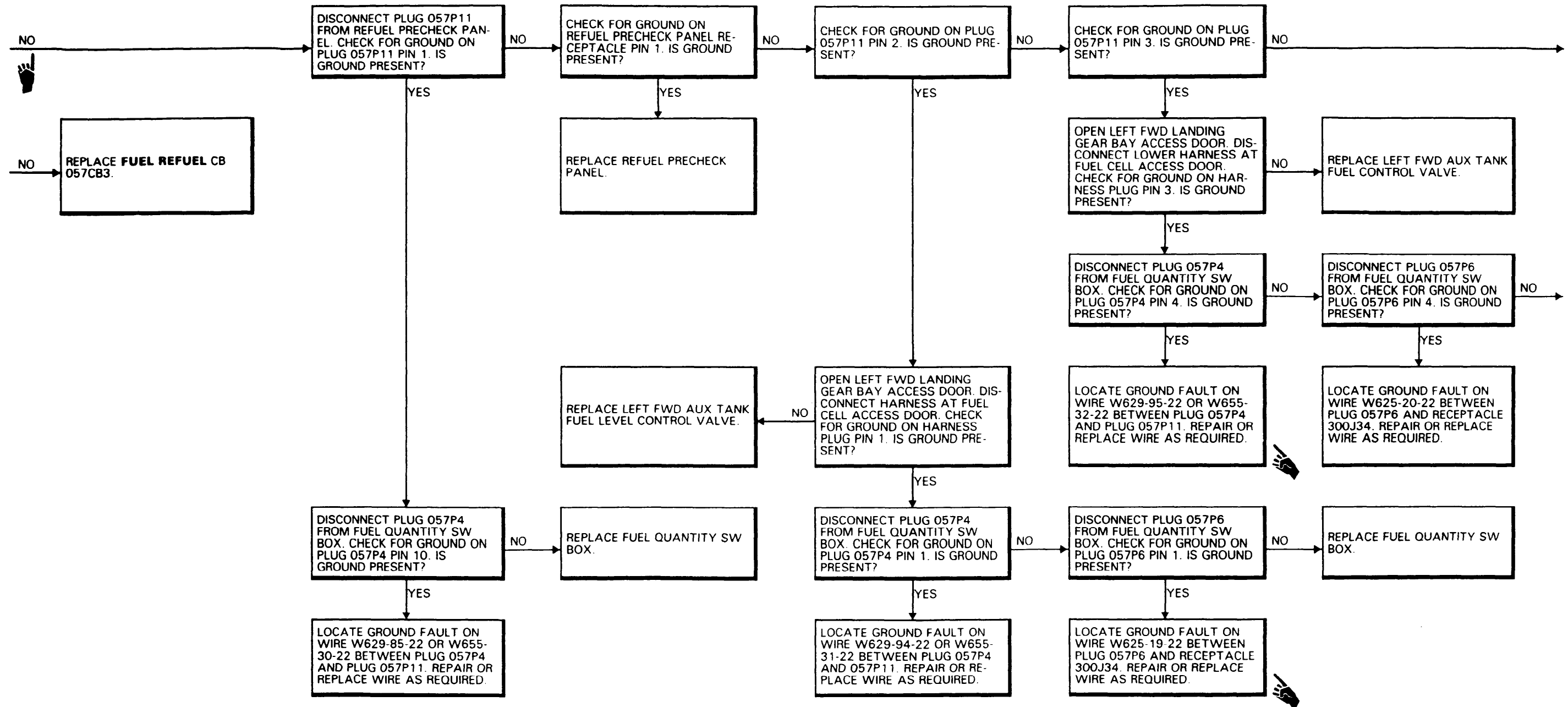

10-3.5 FUEL REFUEL CIRCUIT BREAKER WILL NOT STAY CLOSED (Continued)

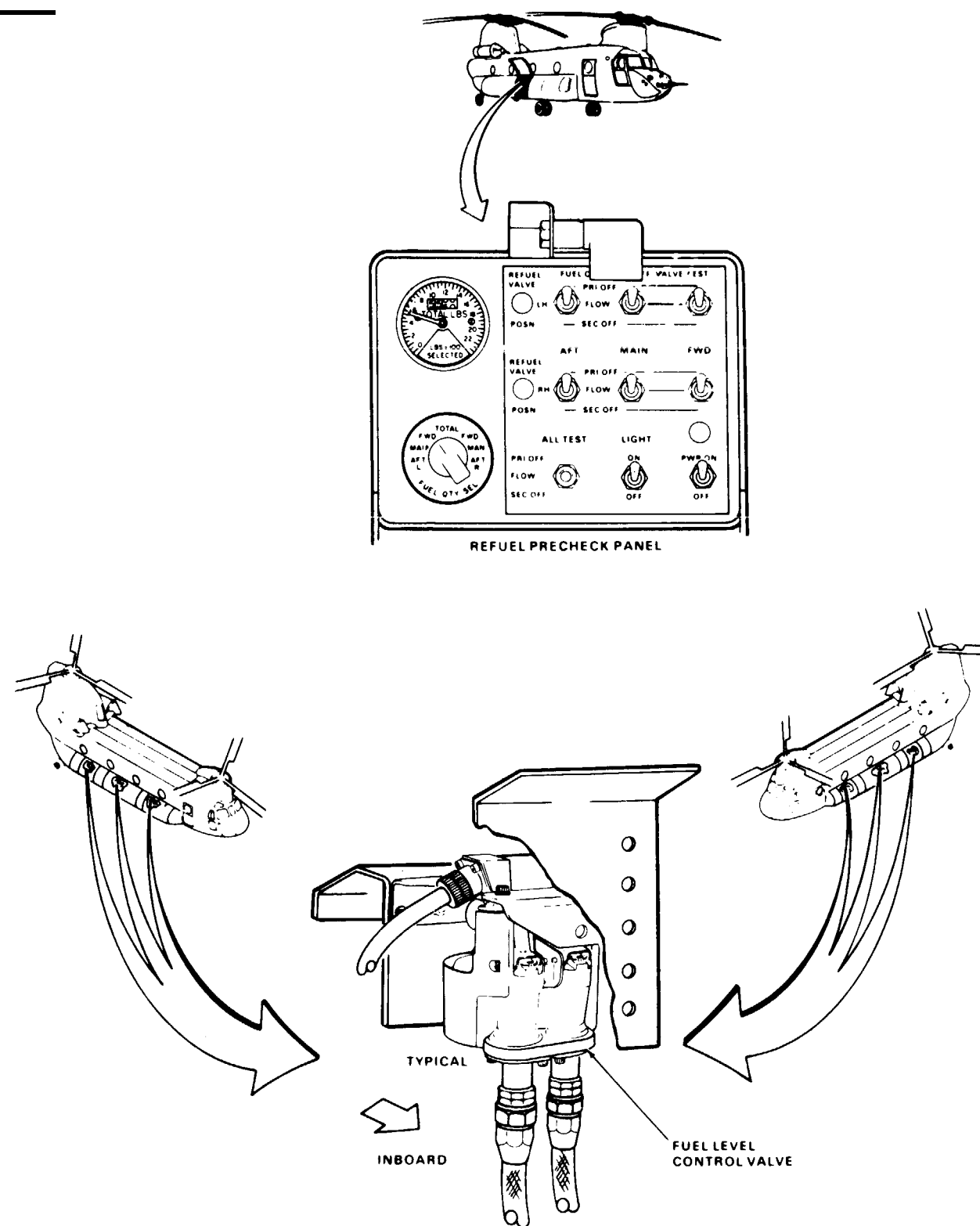
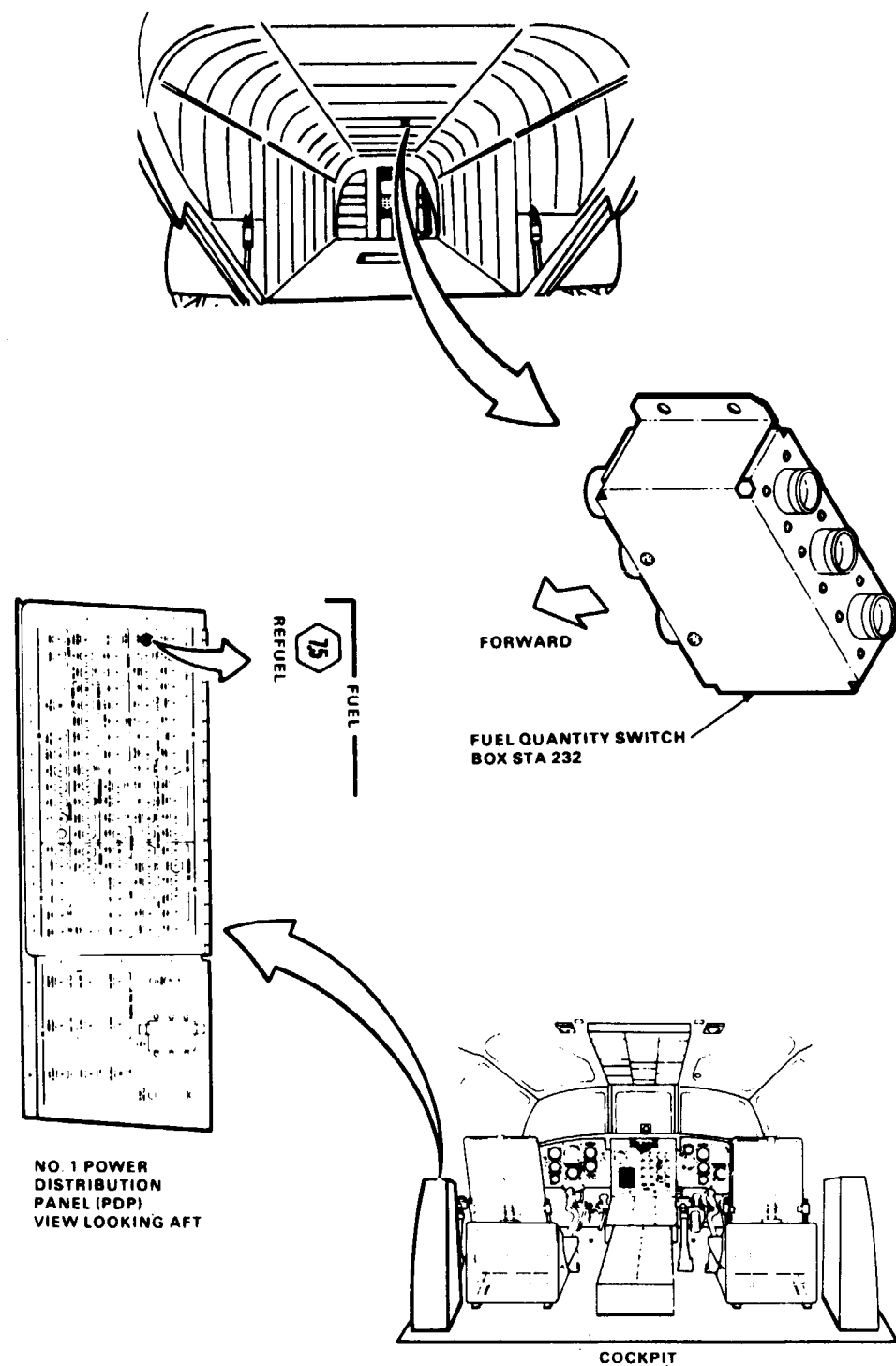

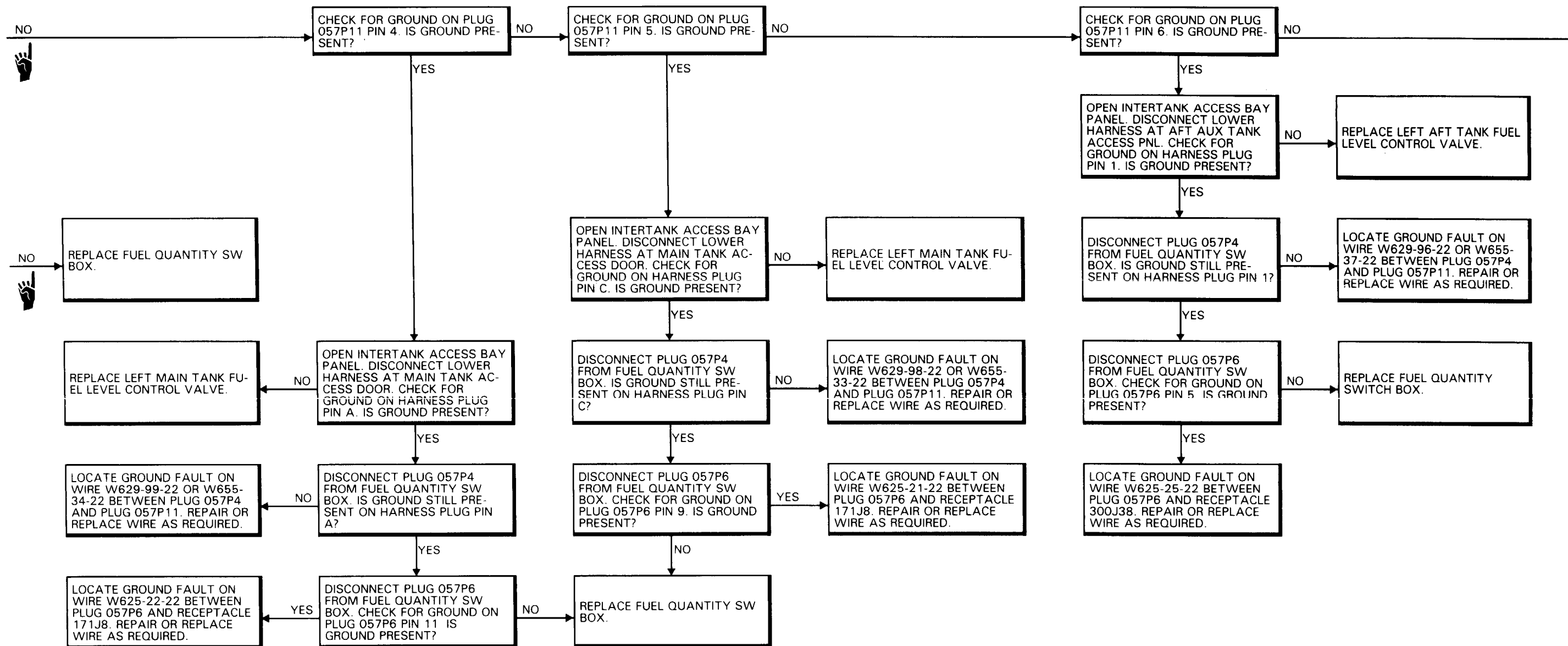

10-3.5 FUEL REFUEL CIRCUIT BREAKER WILL NOT STAY CLOSED (Continued)

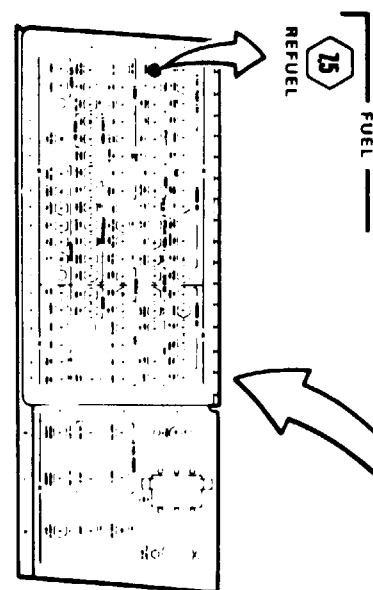
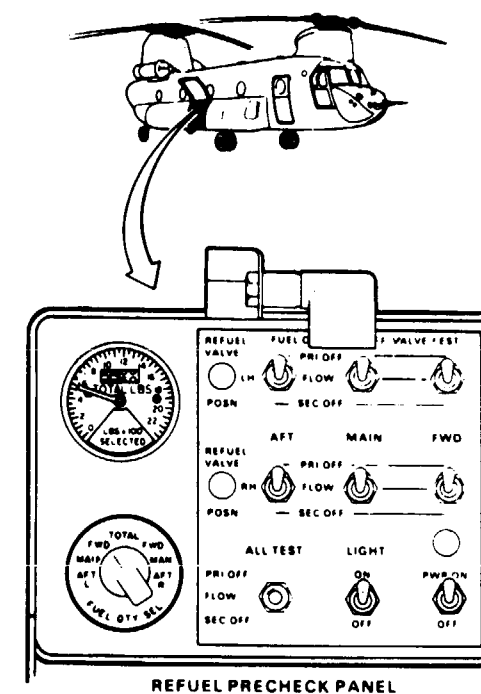
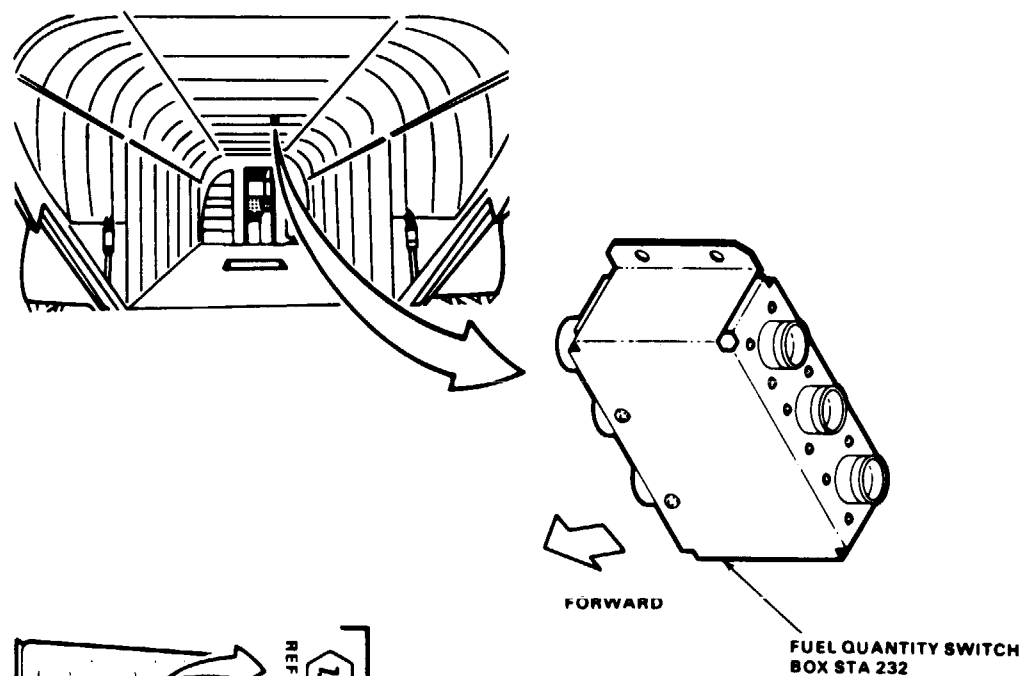

NO. 1 POWER DISTRIBUTION PANEL (PDP) VIEW LOOKING AFT

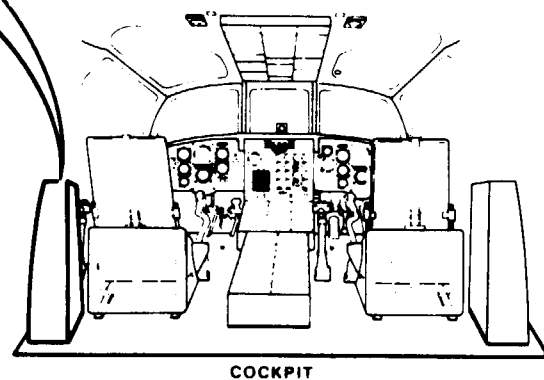

COCKPIT

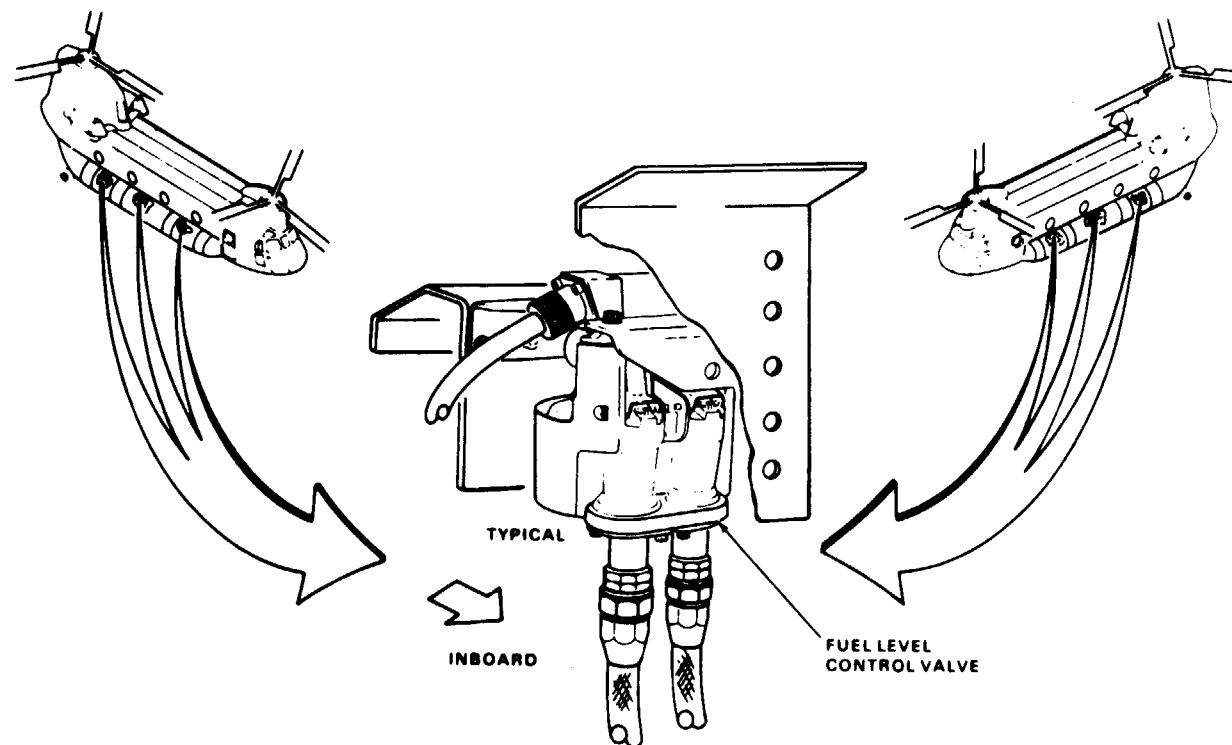

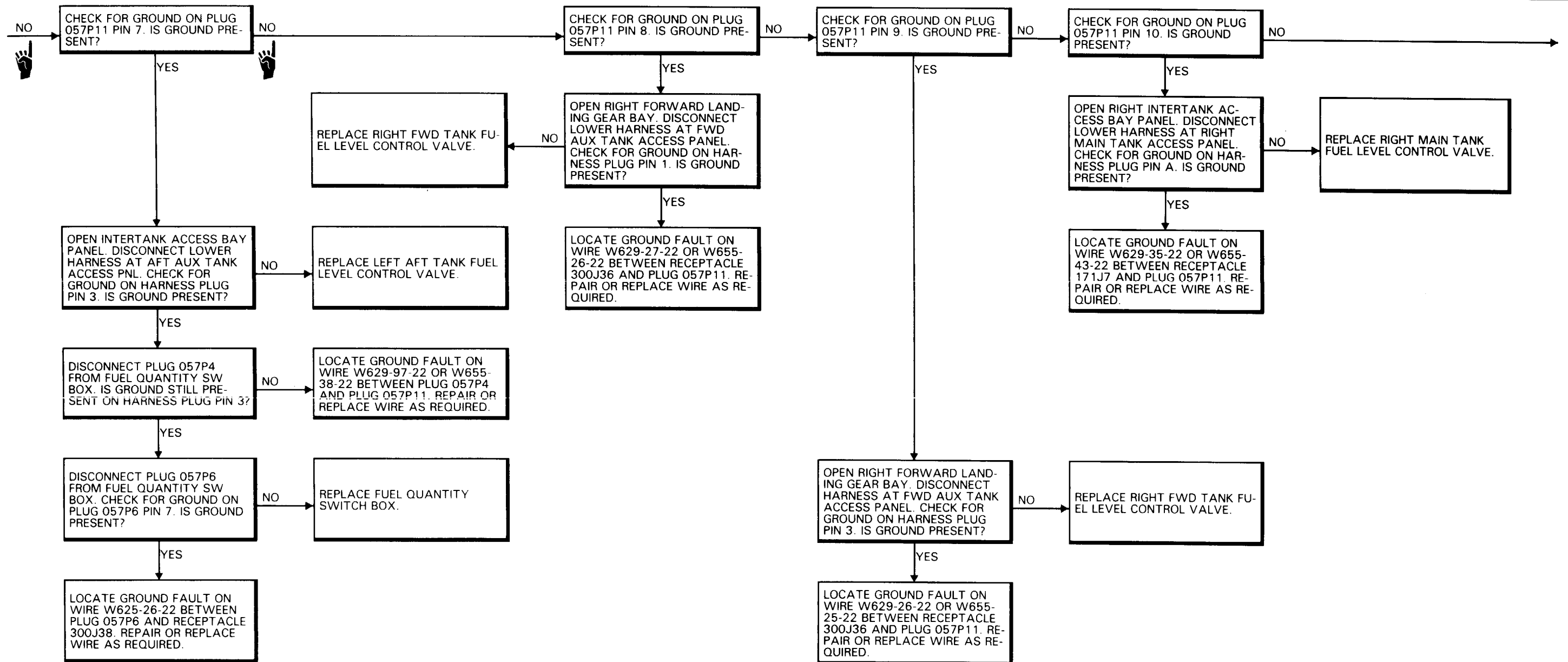

10-3.5 FUEL REFUEL CIRCUIT BREAKER WILL NOT STAY CLOSED (Continued)

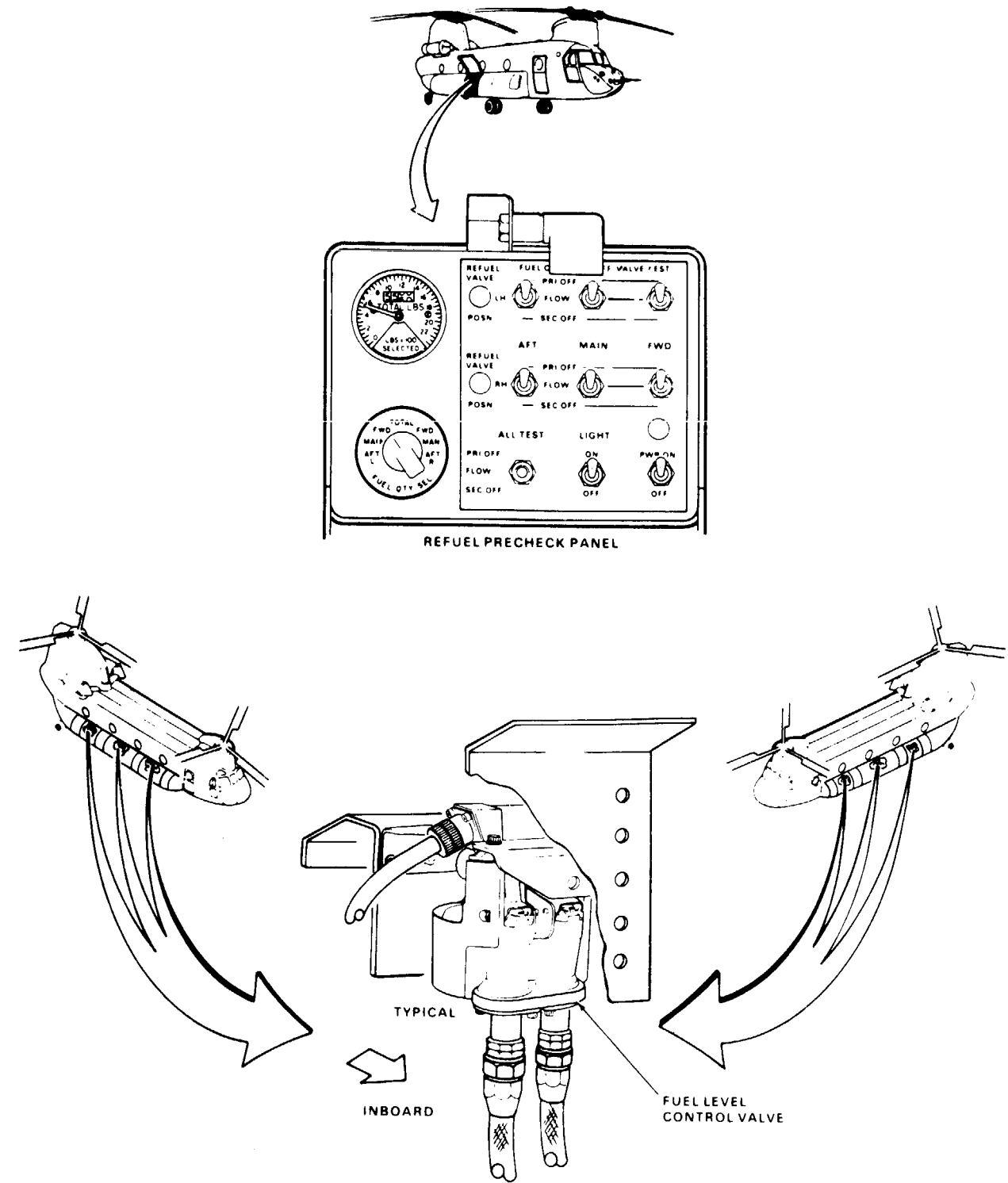
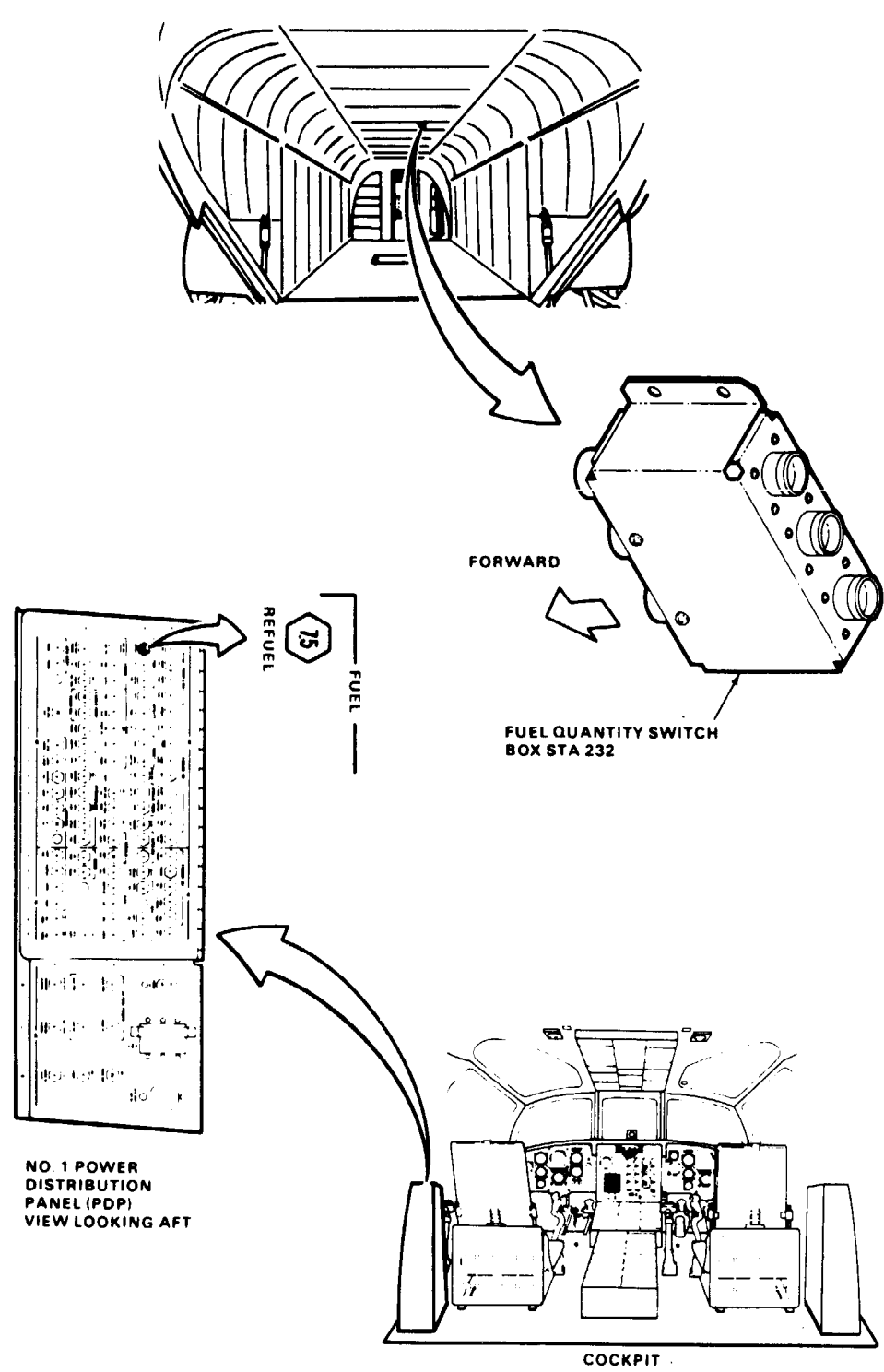

10-3.5 FUEL REFUEL CIRCUIT BREAKER WILL NOT STAY CLOSED (Continued)

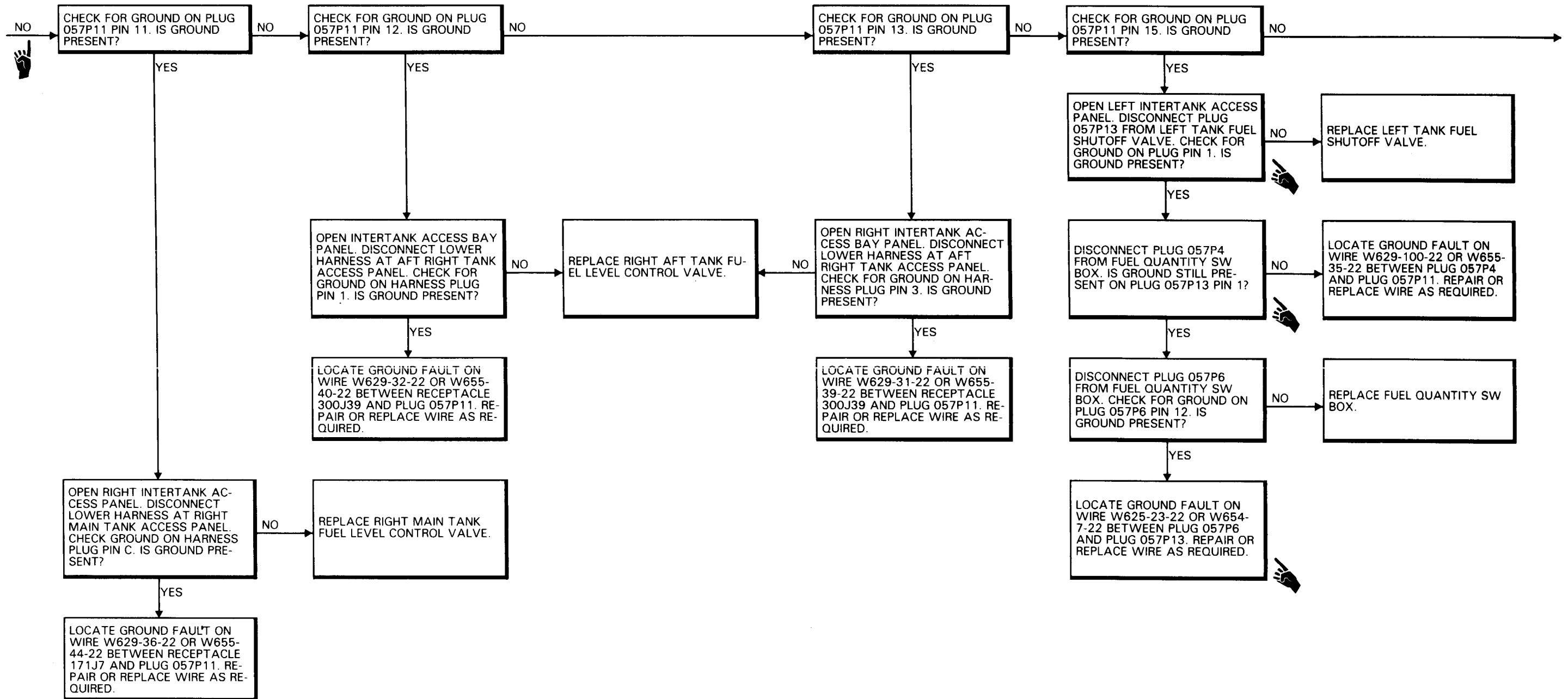

10-3.5 FUEL REFUEL CIRCUIT BREAKER WILL NOT STAY CLOSED (Continued)

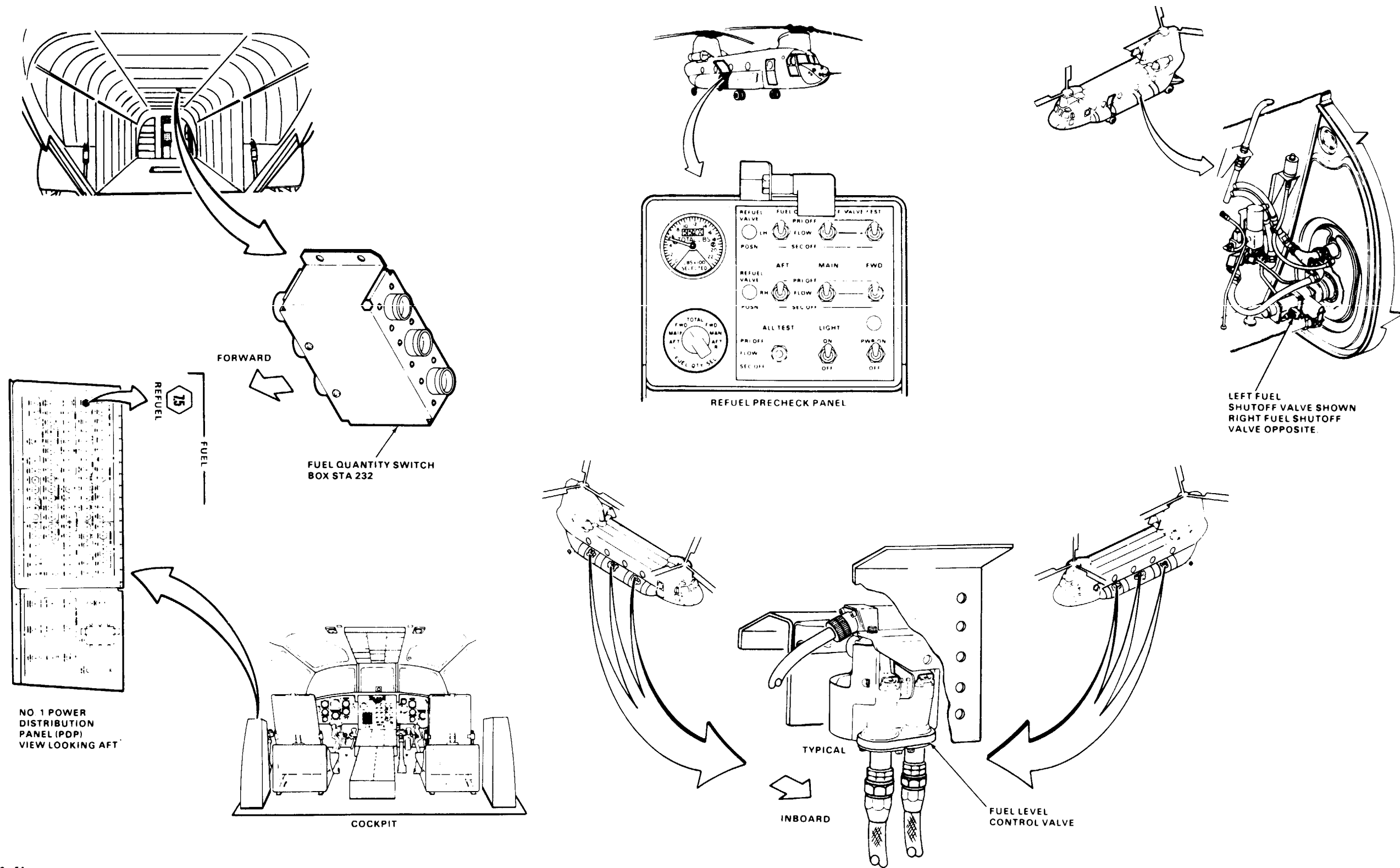

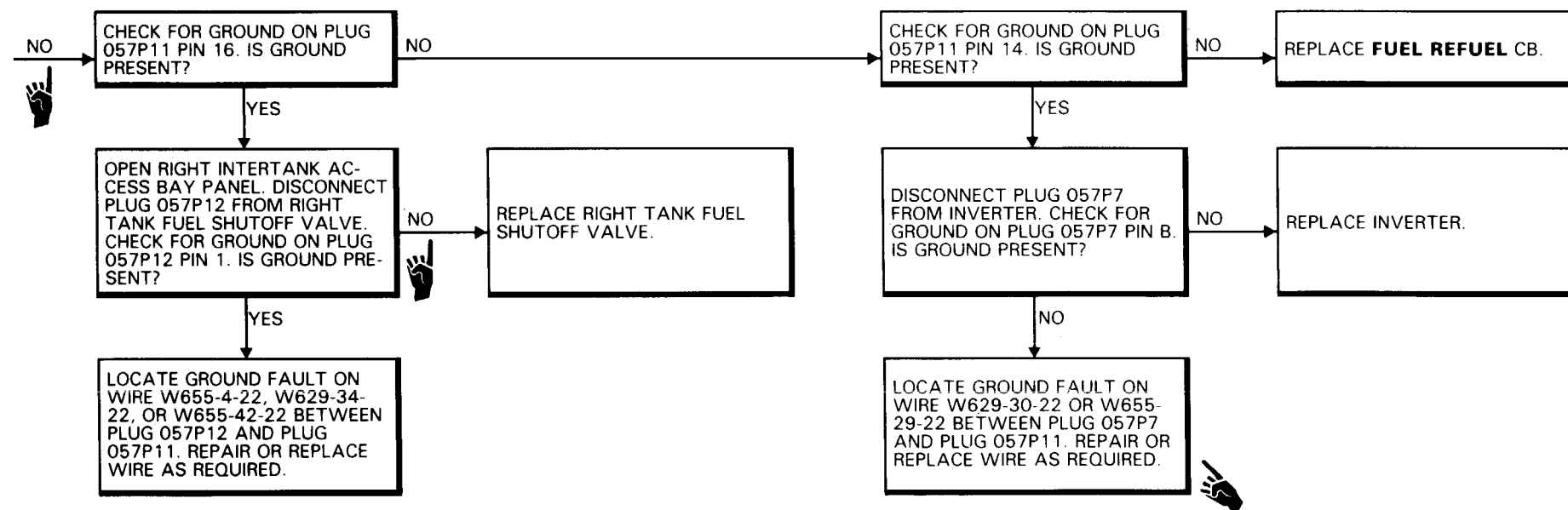

10-3.5 FUEL REFUEL CIRCUIT BREAKER WILL NOT STAY CLOSED (Continued)

10-3.5

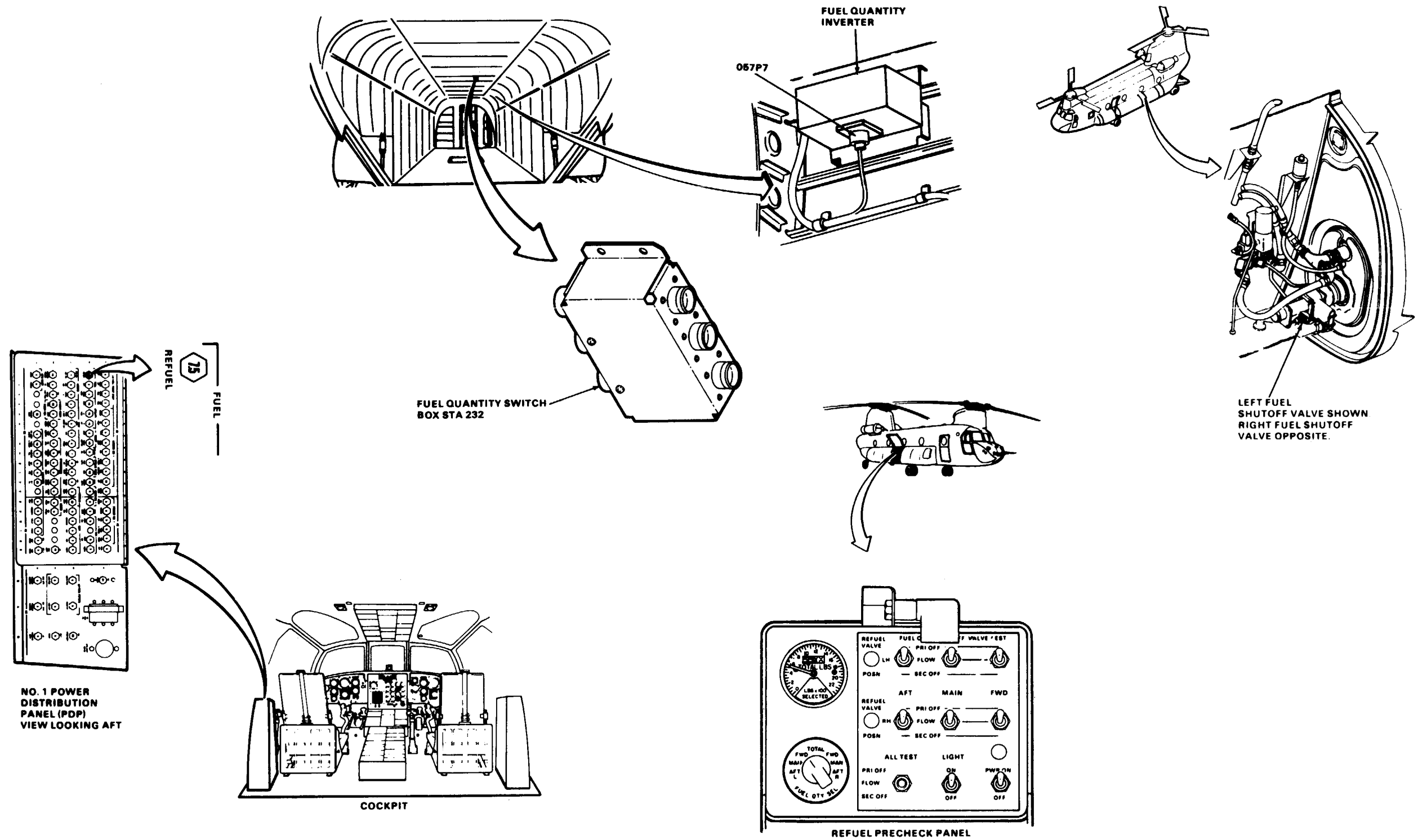

10-3.6 LH OR RH REFUEL VALVE POSN LIGHT
IS ON

FAULT ISOLATION PROCEDURE

INITIAL SETUP

Applicable Configurations:
All

Tools:
Aircraft Mechanic's Tool Kit,
NSN 5180-00-323-4692
Multimeter

Materials:
None

Personnel Required
67U10 Medium Helicopter Repairer
68F20 Aircraft Electrician

References:
TM 55-1520-240-23

Equipment Condition:
TM 55-1520-240-23:
Battery Connected
Electrical Power On
Hydraulic Power Off

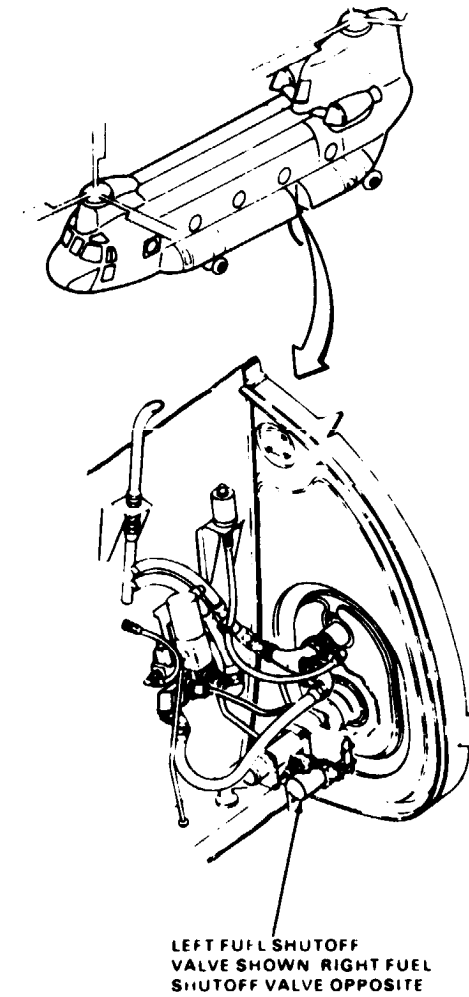

RIGHT REFUEL VALVE POSN LIGHT IS ON

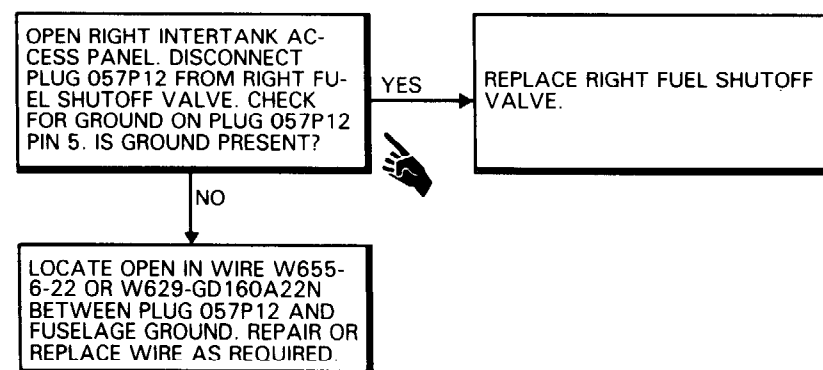

LEFT REFUEL VALVE POSN LIGHT IS ON

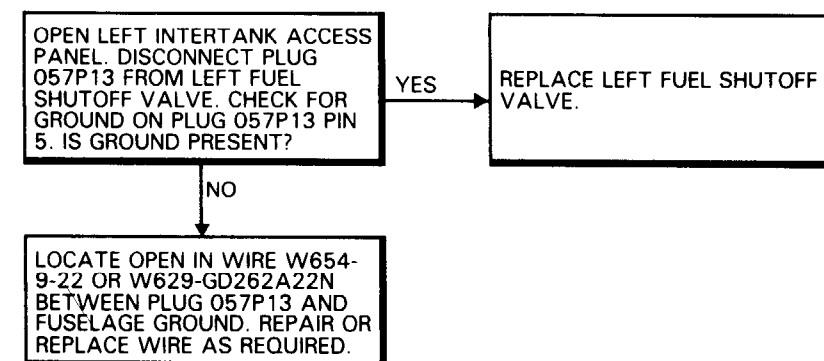

10-3.7 LH OR RH REFUEL VALVE POSN LIGHT DOES NOT COME ON WHEN PRESSED

FAULT ISOLATION PROCEDURE

INITIAL SETUP

Applicable Configurations:
All

Tools:
Electrical Repairer's Tool Kit,
NSN 5180-00-323-4915
Multimeter

Materials:
None

Personnel Required:
68F20 Aircraft Electrician

References:
TM 55-1520-240-23

Equipment Condition:
TM 55-1520-240-23:
Battery Connected
Electrical Power On
Hydraulic Power Off

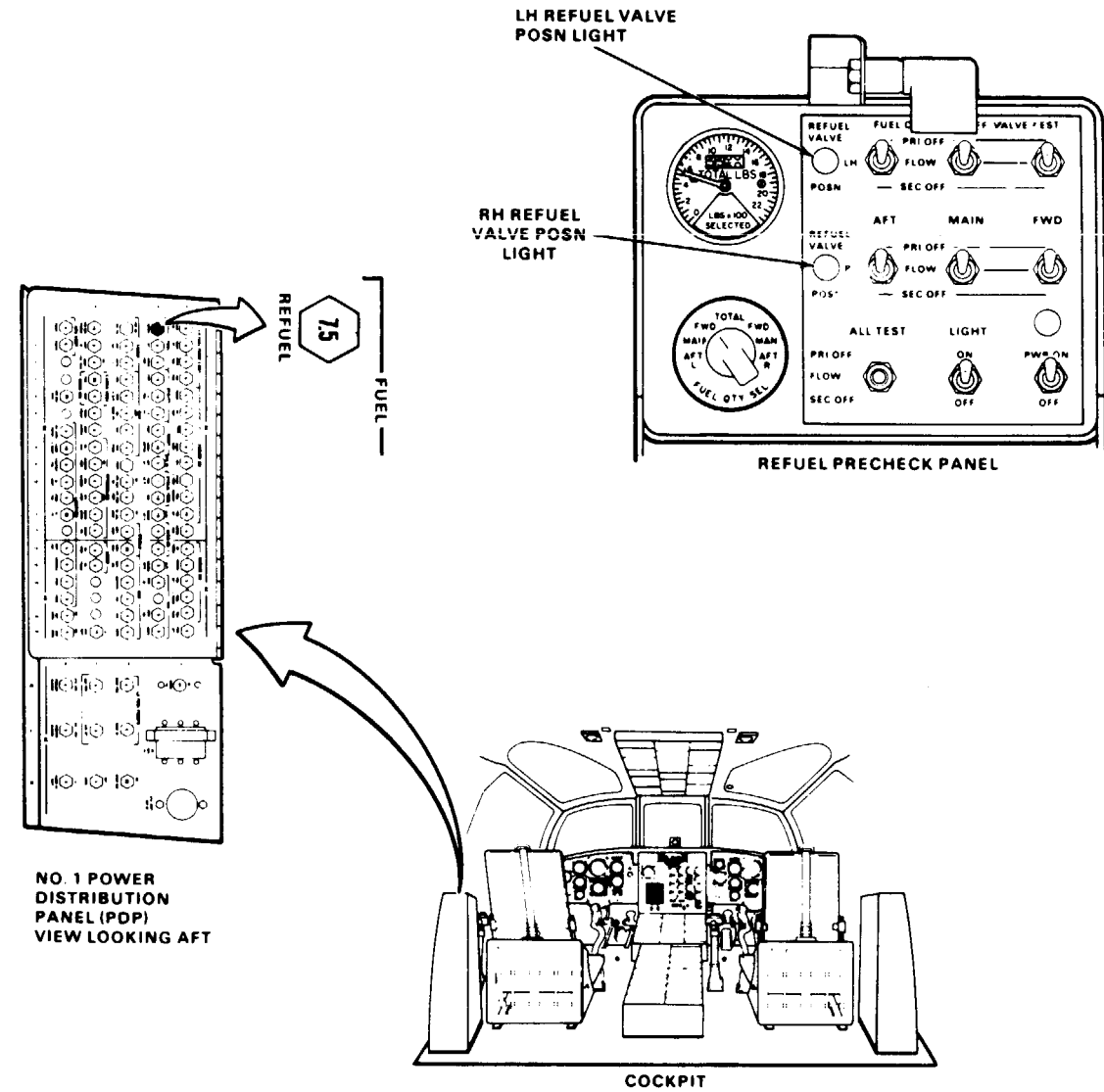
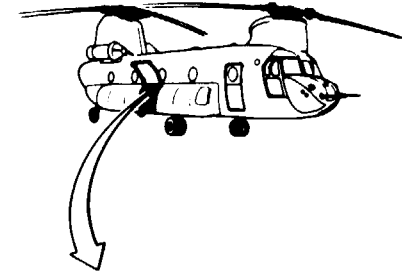

10-3.7 LH OR RH REFUEL VALVE POSN LIGHT DOES NOT COME ON WHEN PRESSED (Continued)

10-3.7

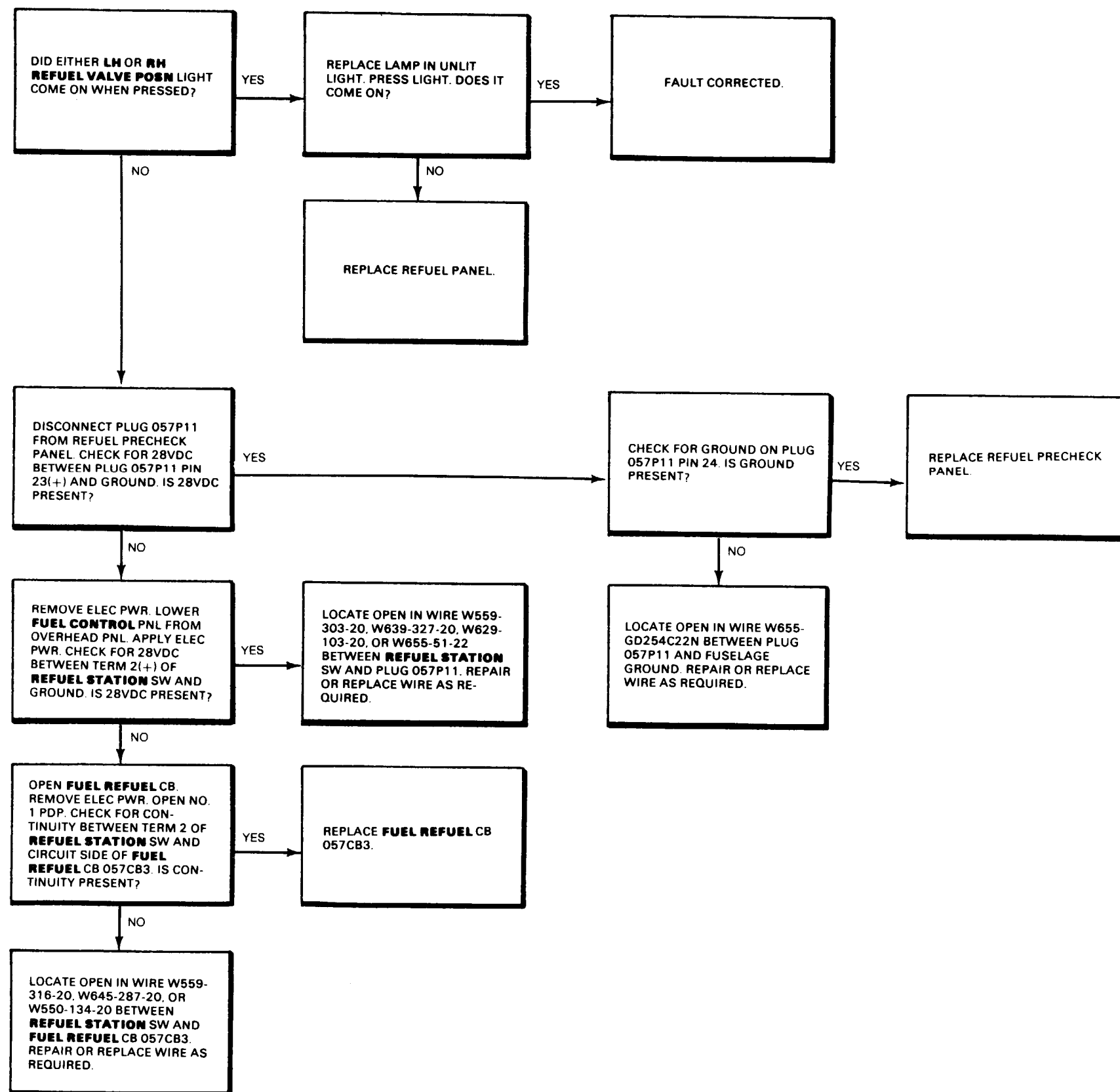

END OF TASK

10-3.8 PWR LIGHT DOES NOT COME ON

FAULT ISOLATION PROCEDURE

INITIAL SETUP

Personnel Required:
68F20 Aircraft Electrician

Applicable Configurations:
All

References:
TM 55-1520-240-23

Tools:
Electrical Repairer's Tool Kit,
NSN 5180-00-323-4915
Multimeter

Equipment Condition:
TM 55-1520-240-23:
Battery Connected
Electrical Power On
Hydraulic Power Off

Materials:
None

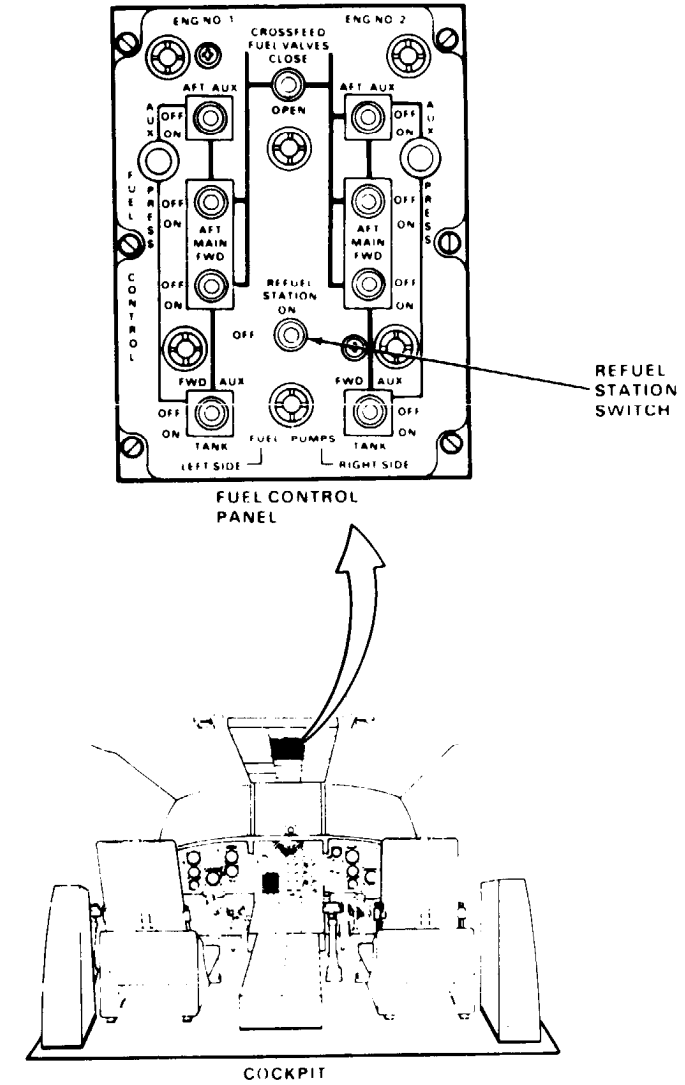
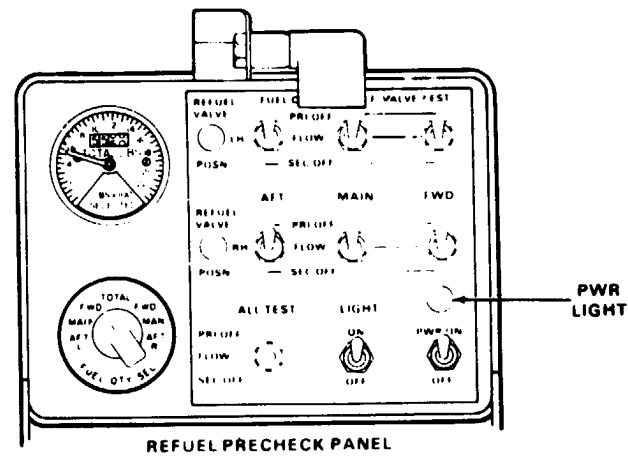
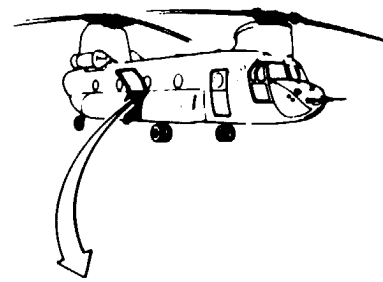

GO TO NEXT PAGE

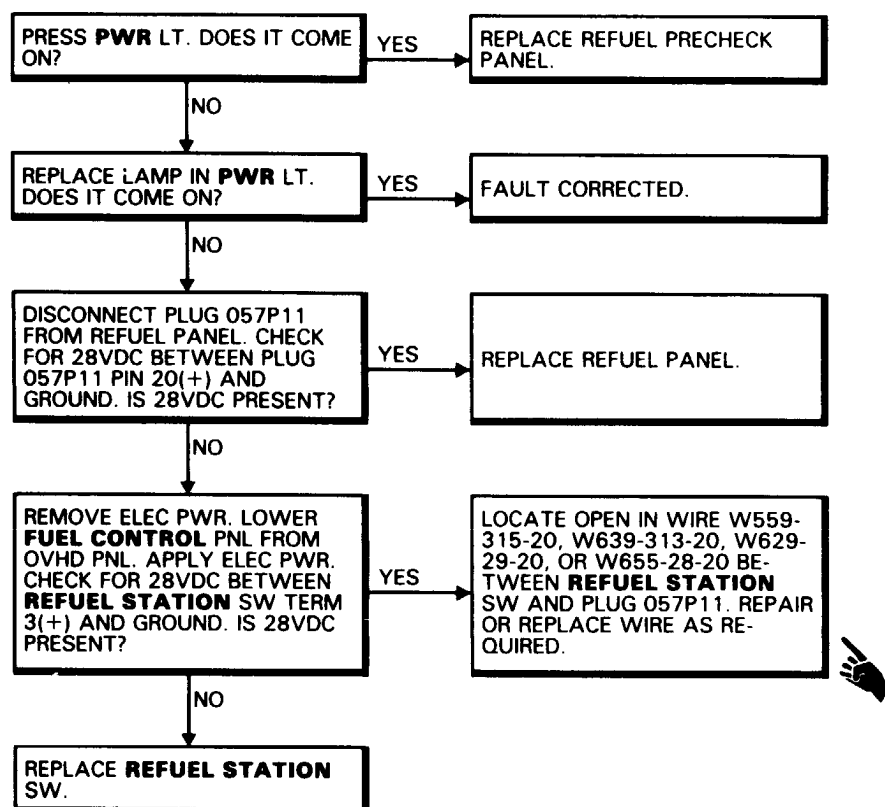

10-3.9 LH OR RH REFUEL VALVE POSN LIGHT DOES NOT COME ON OR COMES ON AND STAY ON

FAULT ISOLATION PROCEDURE

INITIAL SETUP

Applicable Configurations:

All

Tools:

- Electrical Repairer's Tool Kit,
- NSN 5180-00-323-4915
- Multimeter

Materials:

None

Personnel Required:

- 68F10 Aircraft Electrician
- 68F20 Aircraft Electrician

References:

- TM 55-1520-240-23:
- Battery Connected
- Electrical Power On
- Hydraulic Power Off

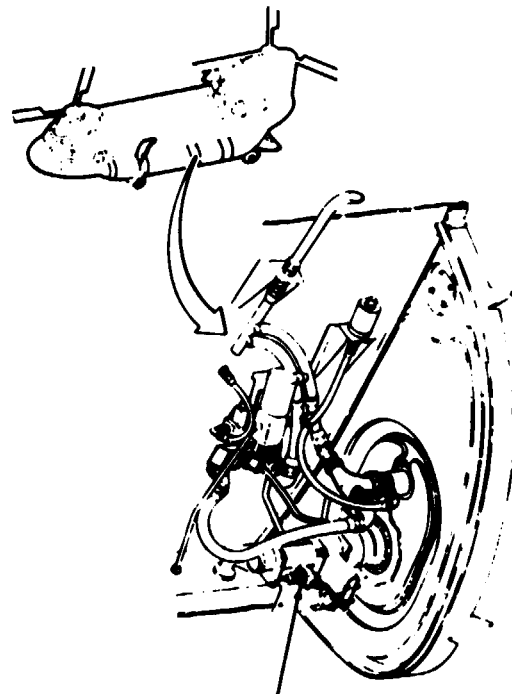

LEFT FUEL LEVEL SHUTOFF VALVES SHOWN. RIGHT FUEL LEVEL SHUTOFF VALVES SIMILAR.

90X94

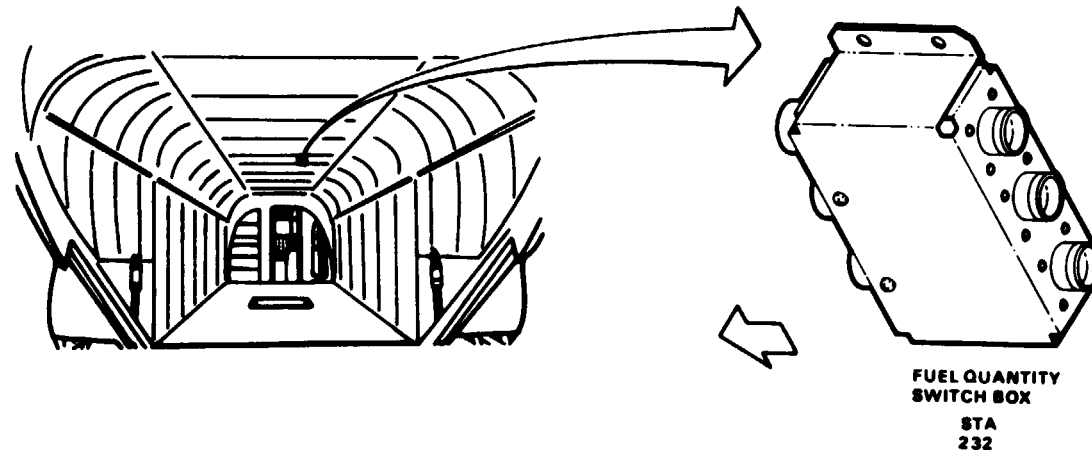

FUEL QUANTITY SWITCH BOX
STA 232

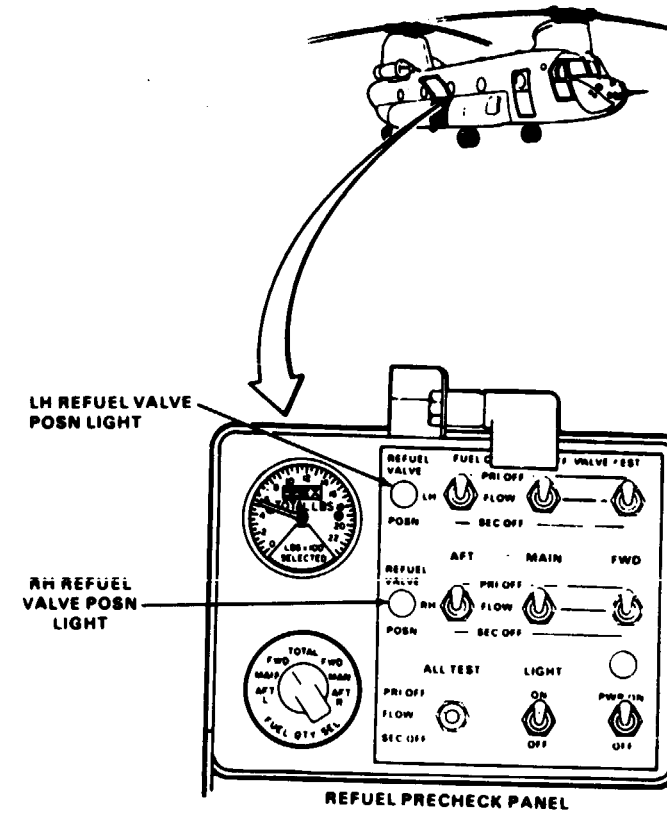

LH REFUEL VALVE POSN LIGHT

RH REFUEL VALVE POSN LIGHT

REFUEL PRECHECK PANEL

0145-11798-SPA

GO TO NEXTPAGE

10-3.9 LH OR RH REFUEL VALVE POSN LIGHT DOES NOT COME ON OR COMES ON AND STAYS ON
(Continued)

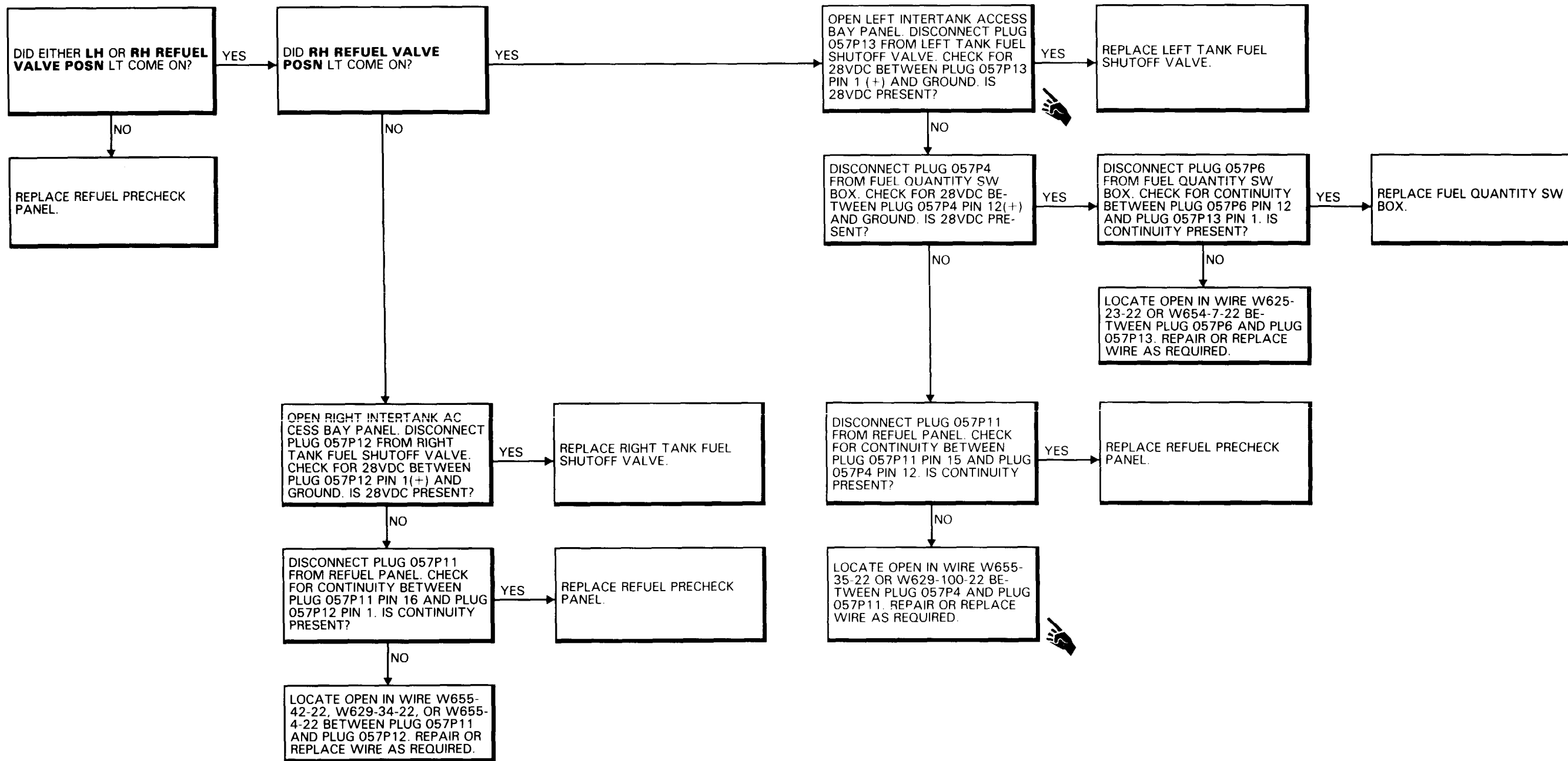

FAULT ISOLATION PROCEDURE

INITIAL SETUP

Personnel Required
68F10 Aircraft Electrician

Applicable Configurations:
All

References:
TM 55-1520-240-23

Tools:
Electrical Repairer's Tool Kit,
NSN 5180-00-323-4915

Equipment Condition:
TM 55-1520-240-23:
Battery Connected
Electrical Power On
Hydraulic Power Off

Materials:
None

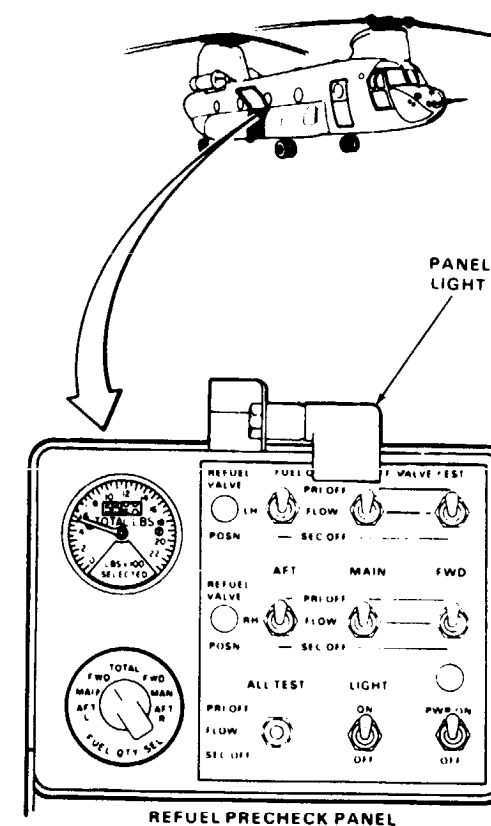
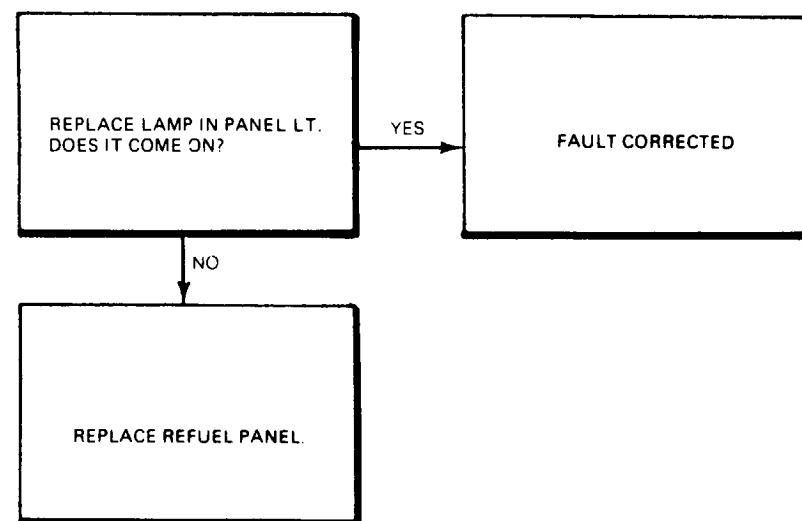

D145-11799-SPA

END OF TASK

This page intentionally left blank

**Task 10-3.11 Deleted.
Pages 10-152 and 10-153 Deleted.**

10-3.12 FUEL DOES NOT STOP FLOWING WITHIN
4 SECONDS WITH ALL TEST SWITCH
AT PRI OFF

FAULT ISOLATION PROCEDURE

INITIAL SETUP

Applicable Configurations:
All

Tools:
Electrical Repairer's Tool Kit,
NSN 5180-00-323-4915
Aircraft Mechanic's Tool Kit,
NSN 5180-00-323-4692
Multimeter

Materials:
None

Personnel Required:
67U20 Medium Helicopter Repairer
68F20 Aircraft Electrician

References:
TM 55-1520-240-23

Equipment Condition:
TM 55-1520-240-23:
Battery Connected
Aircraft Being Refueled
Hydraulic Power Off

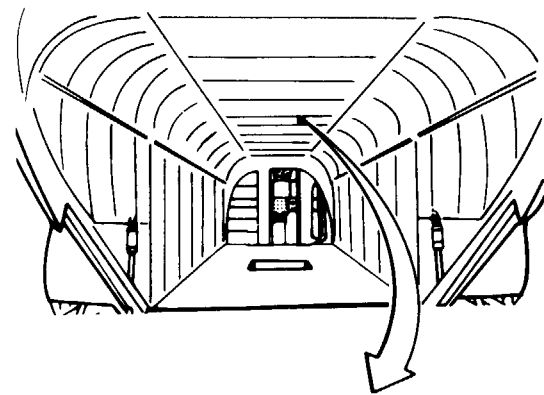
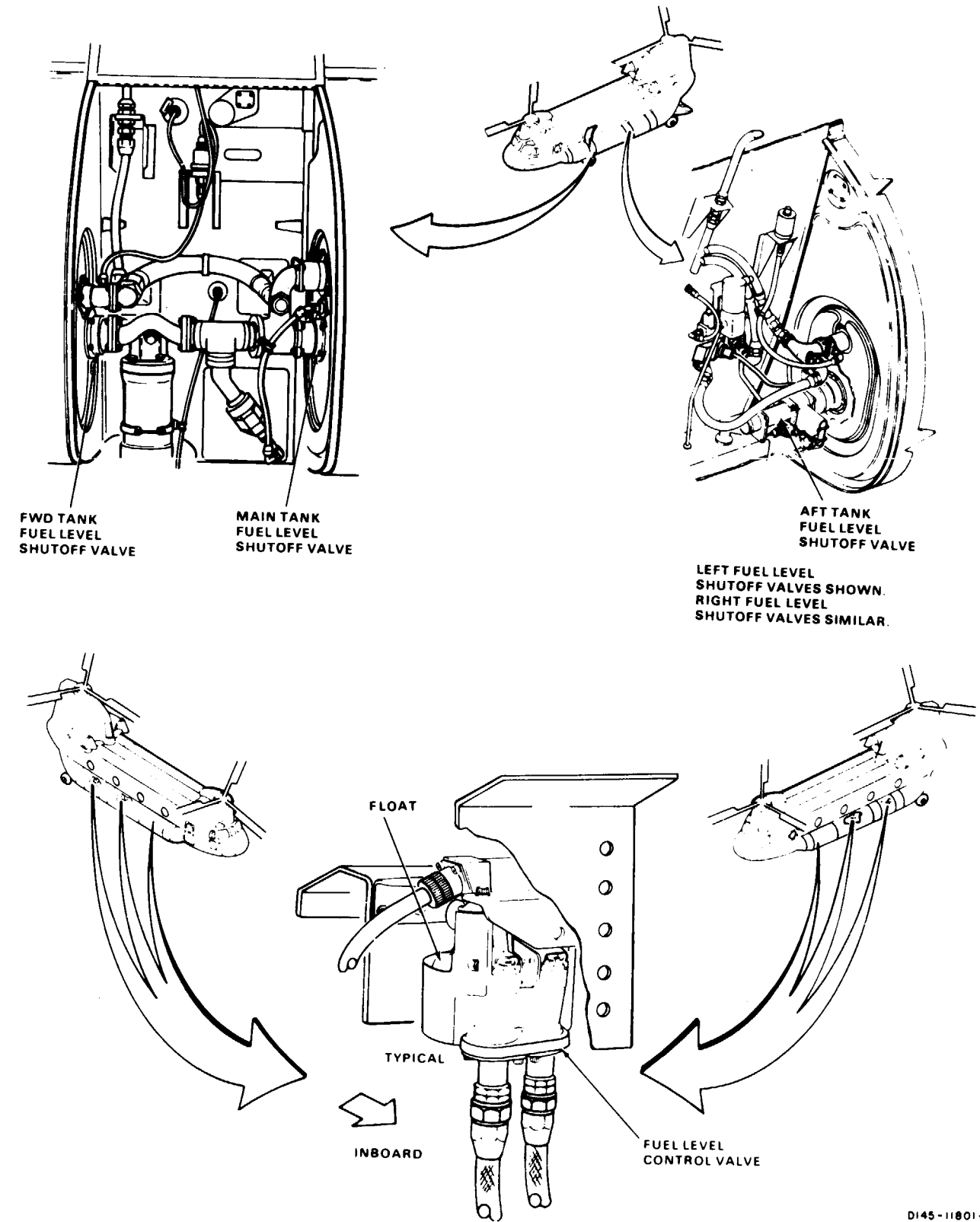

FORWARD

FUEL QUANTITY SWITCH BOX STA 232

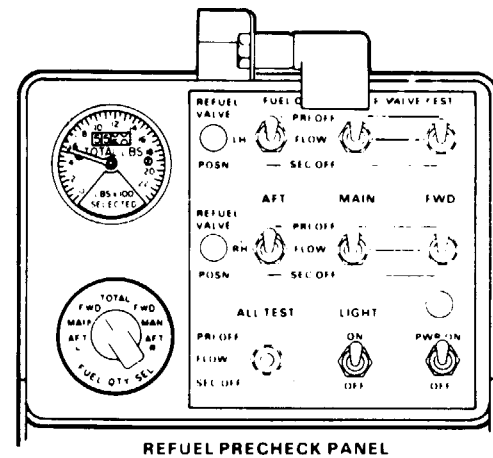
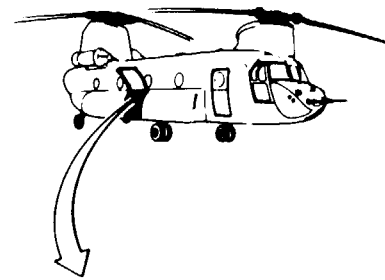

90 X 54

D145-11801-SPA

GO TO NEXT PAGE

10-3.12 FUEL DOES NOT STOP FLOWING WITHIN 4 SECONDS WITH ALL TEST SWITCH AT PRI OFF
(Continued)

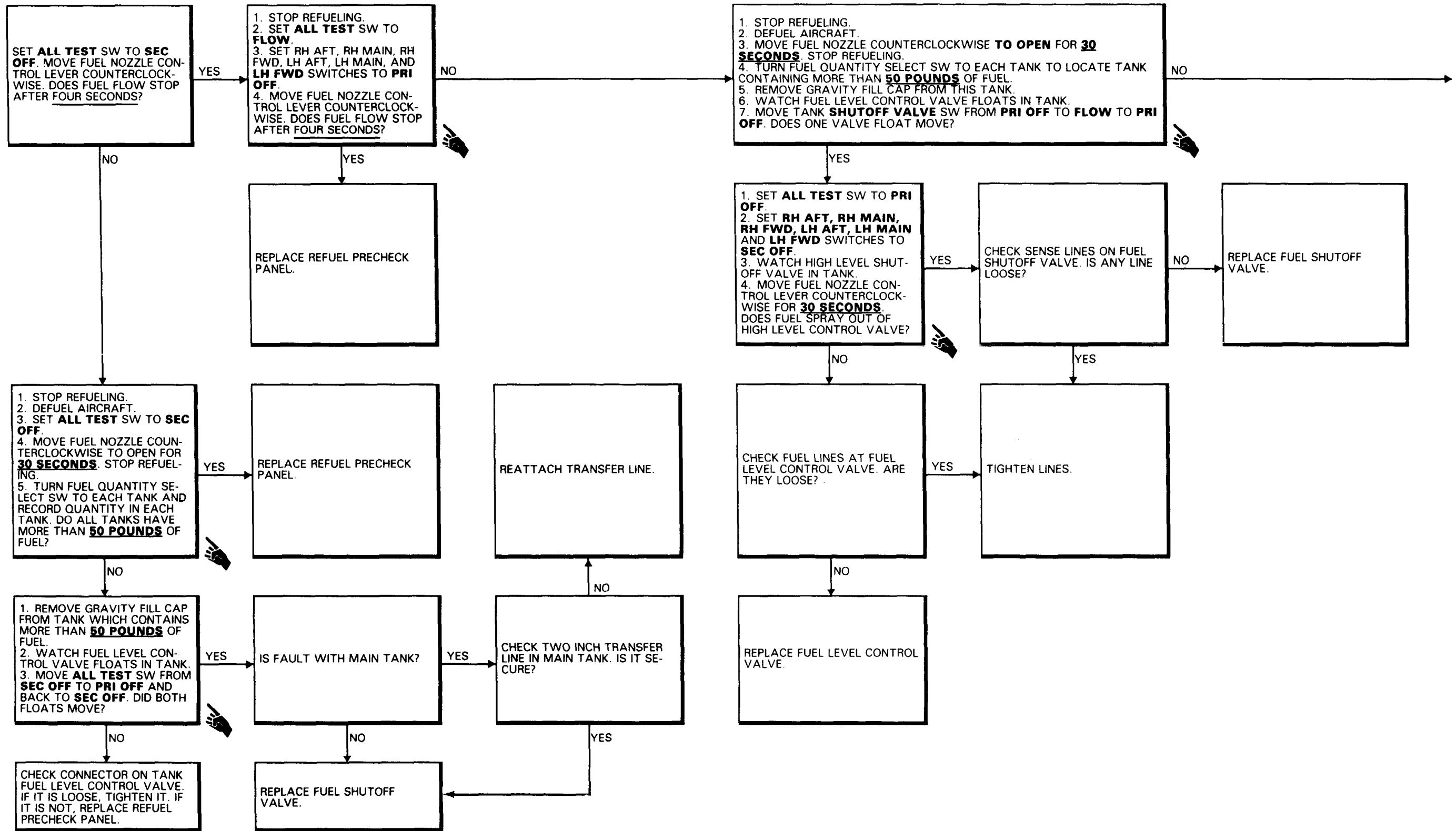

(Continued)

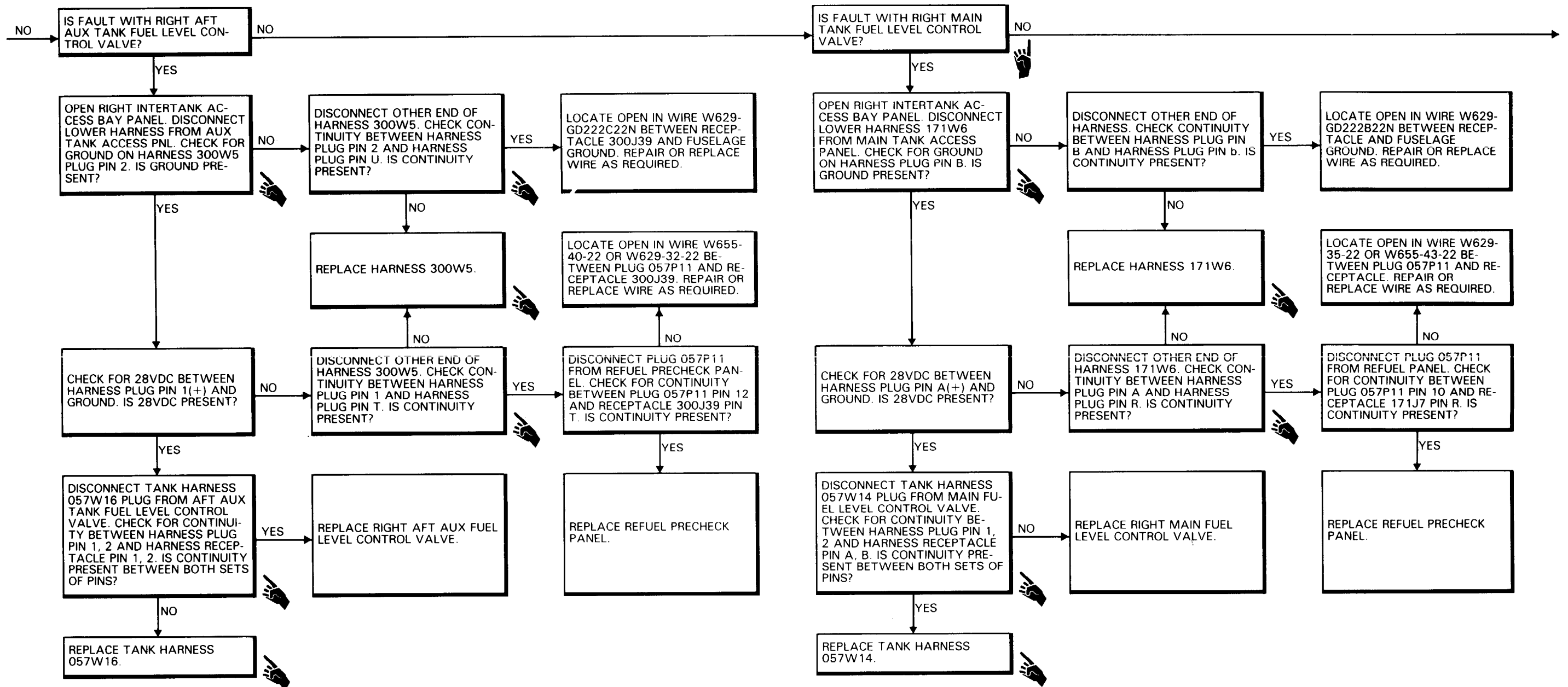

10-3.12 FUEL DOES NOT STOP FLOWING WITH IN
4 SECONDS WITH ALL TEST SWITCH
AT PRI OFF (Continued)

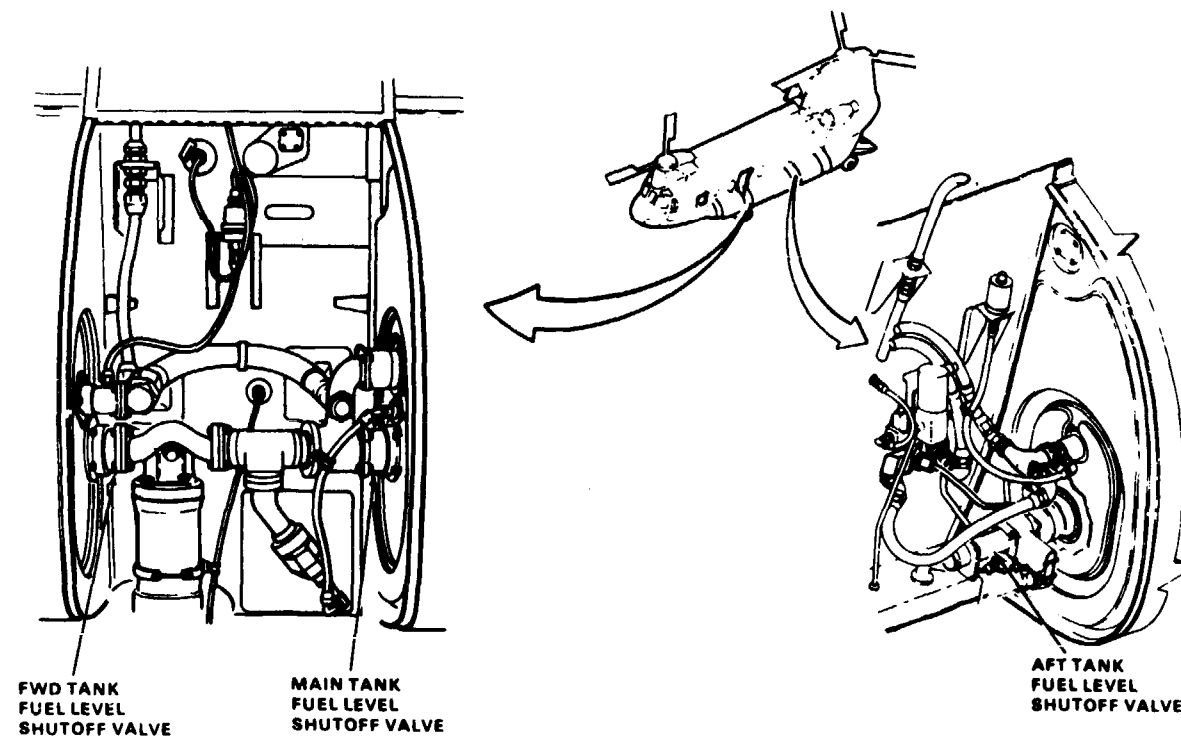

LEFT FUEL LEVEL SHUTOFF VALVES SHOWN. RIGHT FUEL LEVEL SHUTOFF VALVES SIMILAR.

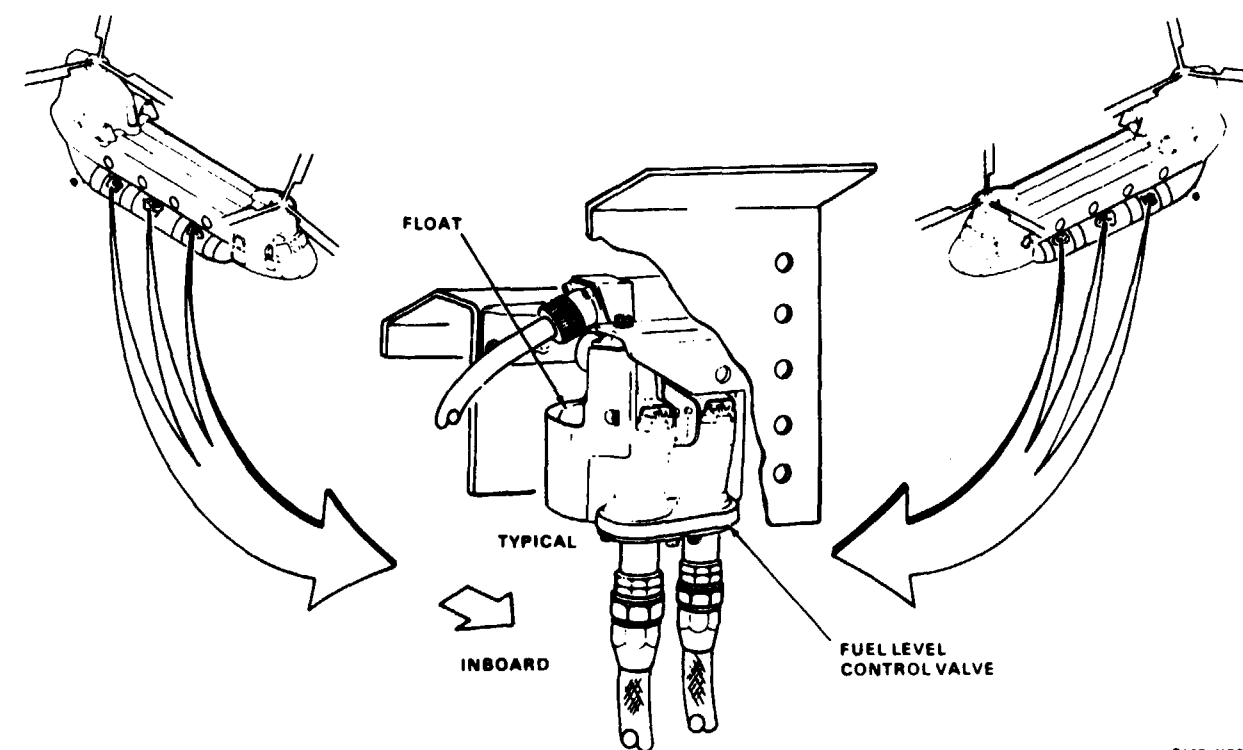
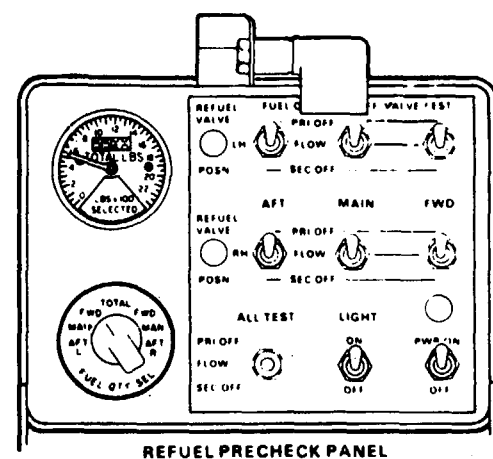
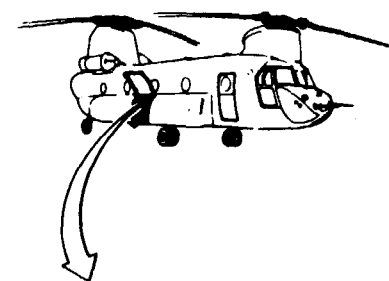
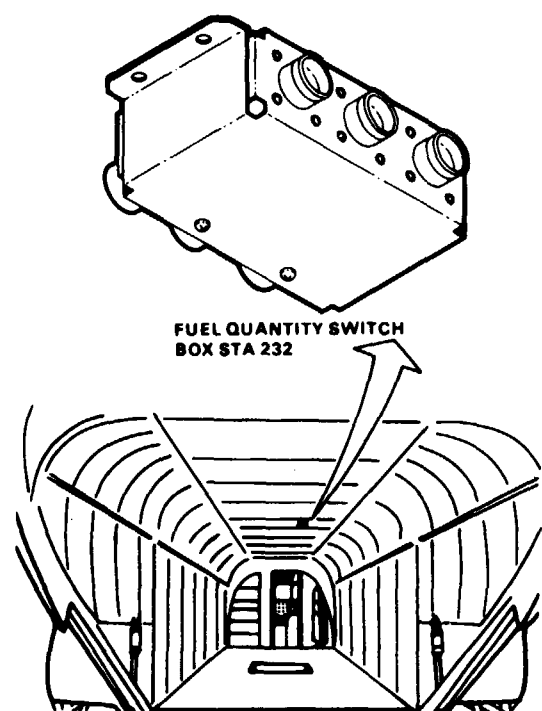

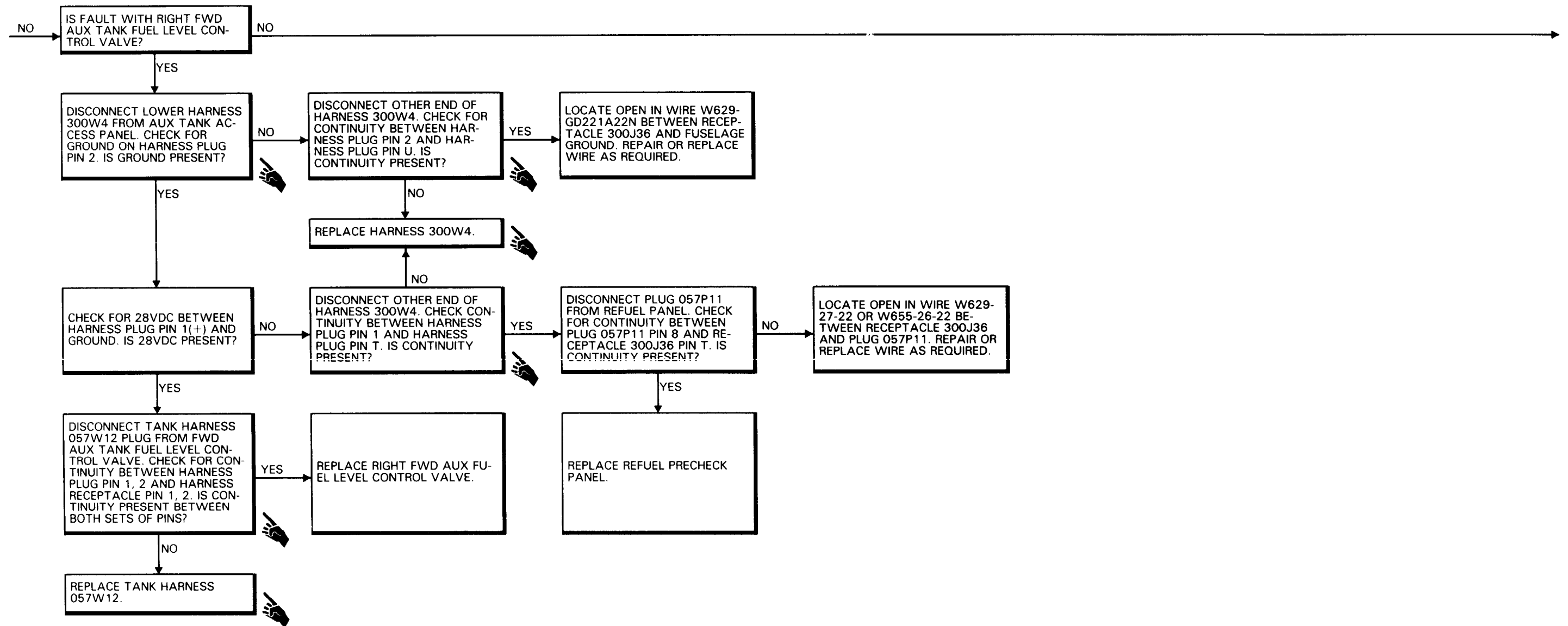

10-3.12 FUEL DOES NOT STOP FLOWING WITHIN
4 SECONDS WITH ALL TEST SWITCH
AT PRI OFF (Continued)

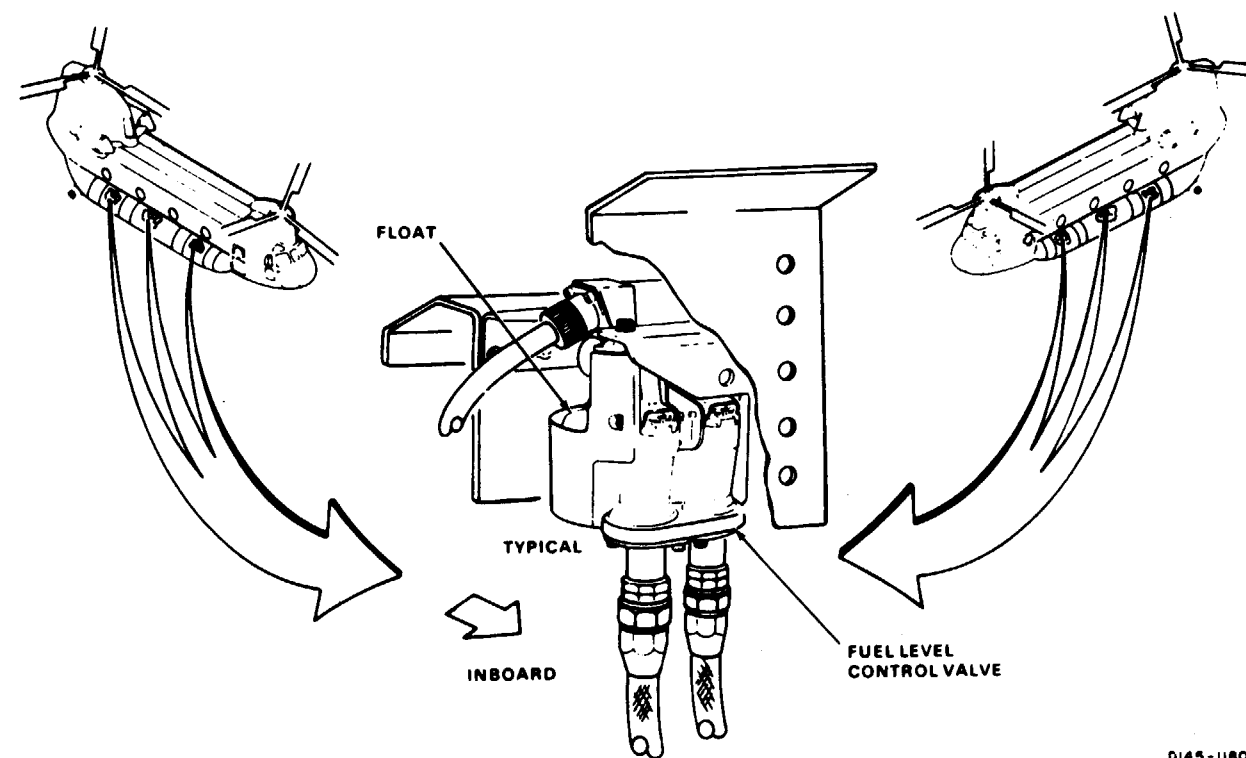
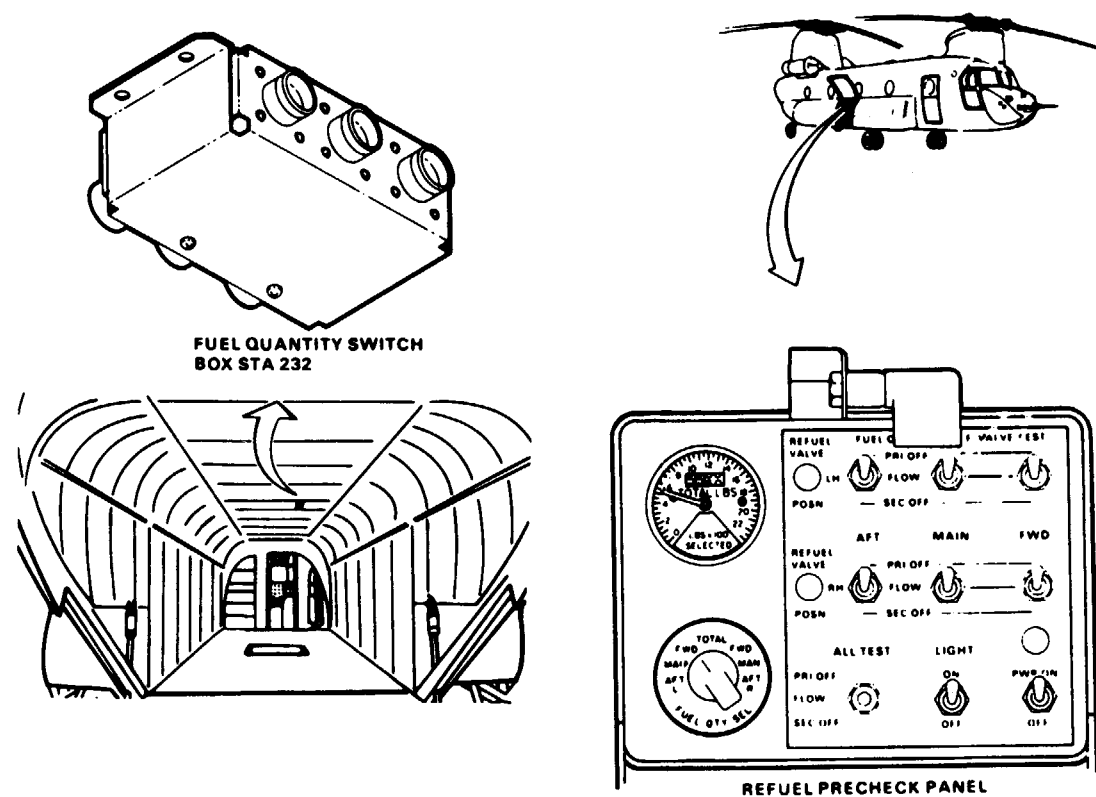
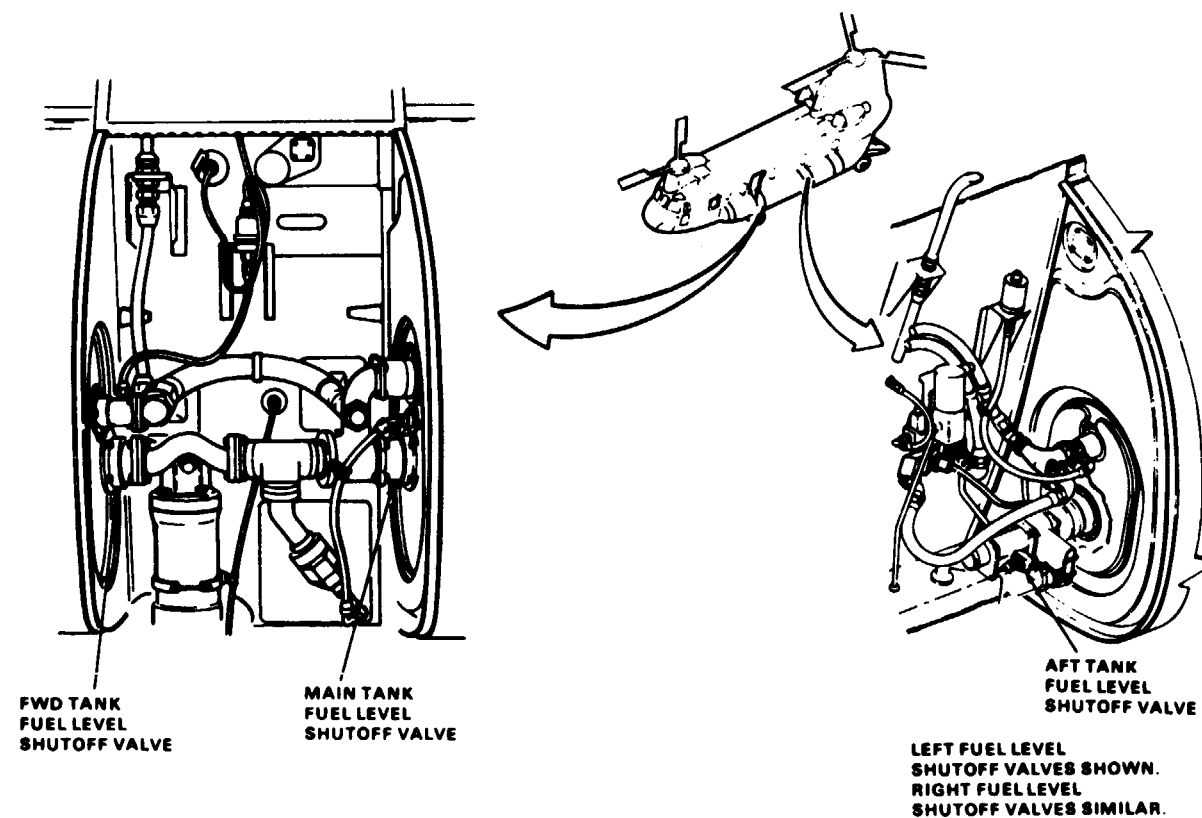

90X54

D145-11803-SPA

GO TO NEXT PAGE

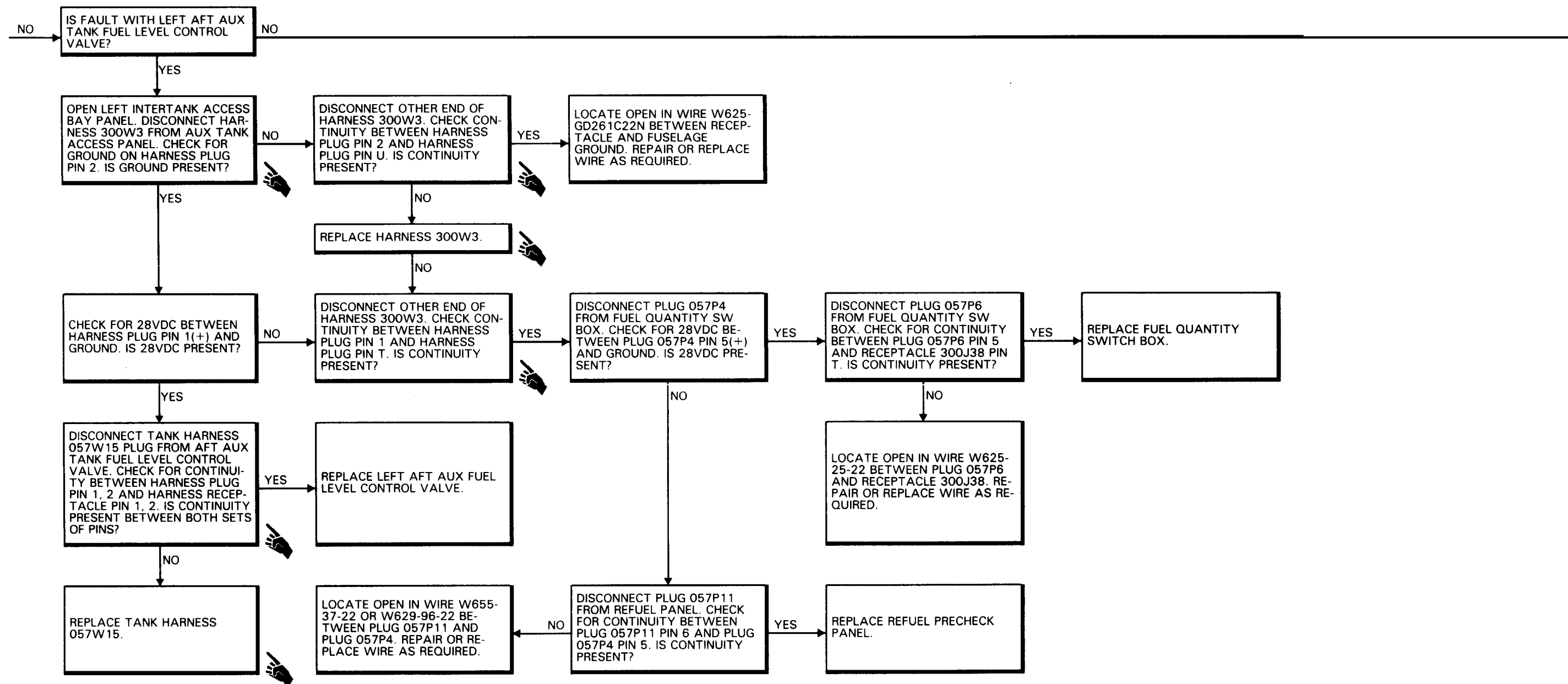

10-3.12 FUEL DOES NOT STOP FLOWING WITHIN
4 SECONDS WITH ALL TEST SWITCH
AT PRI OFF (Continued)

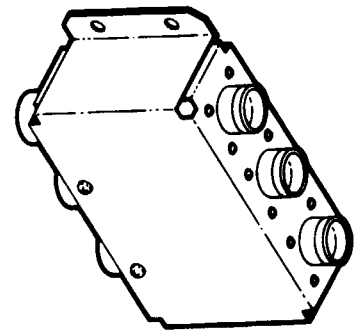
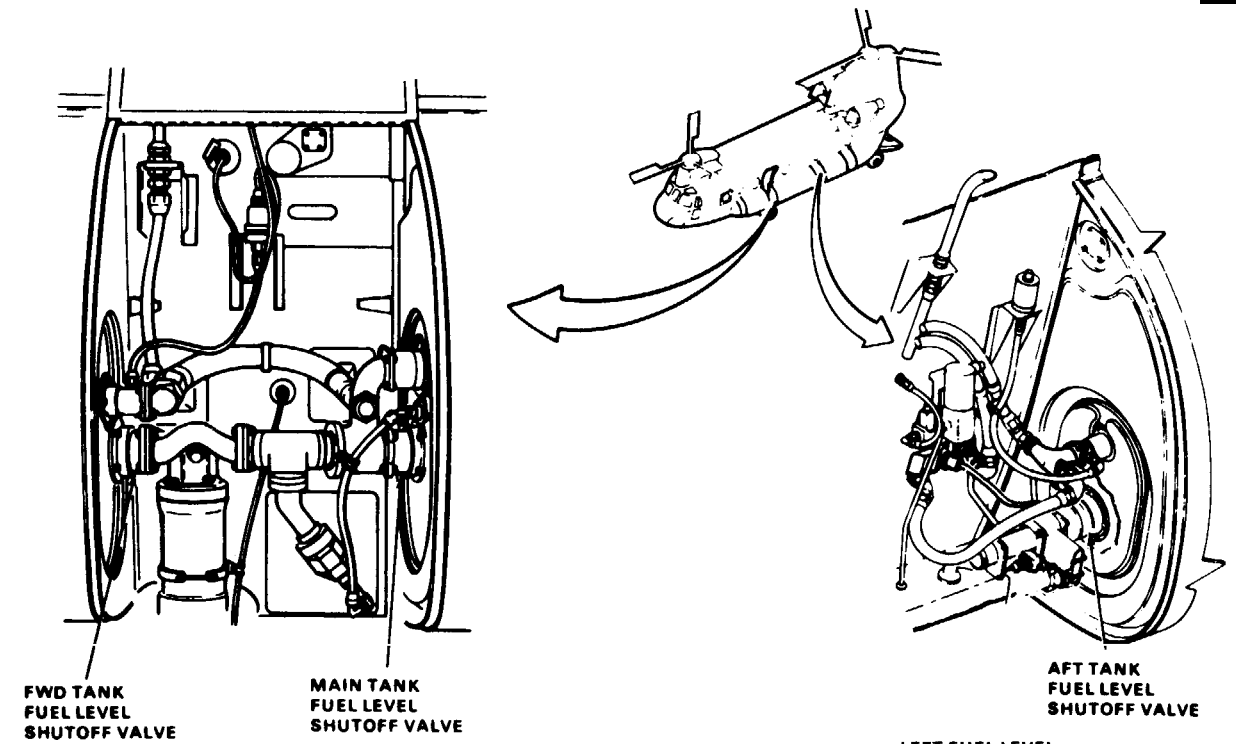

FUEL QUANTITY SWITCH
BOX STA 232

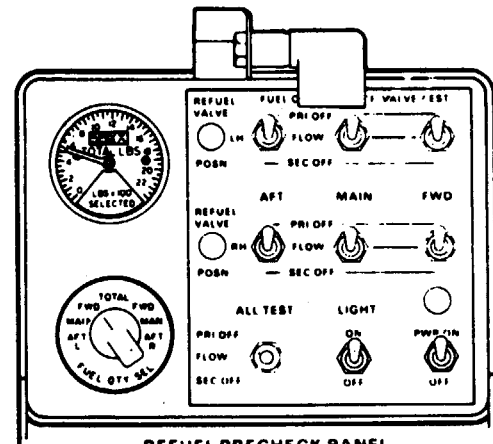
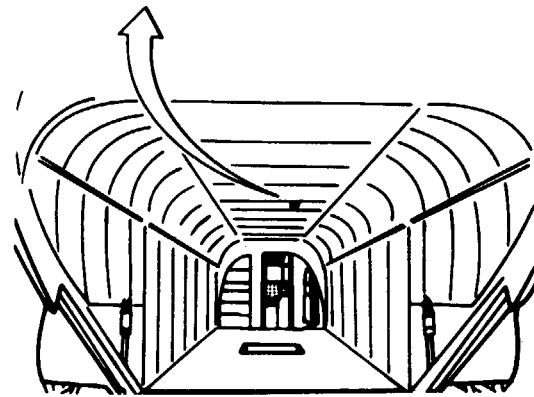
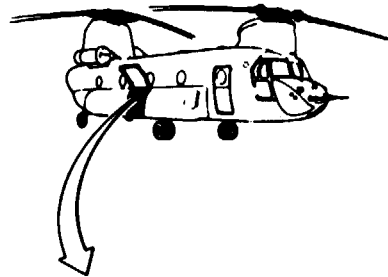

REFUEL PRECHECK PANEL

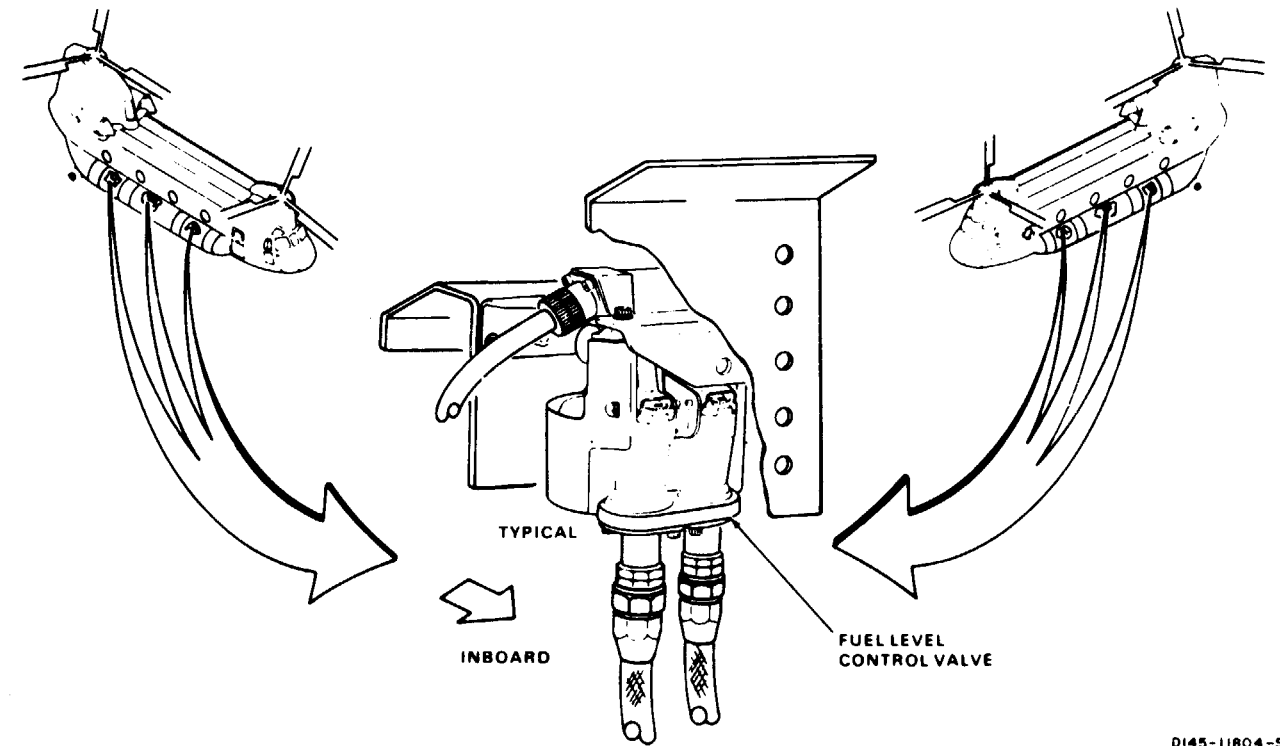

D145-11804-SPA

GO TO NEXT PAGE

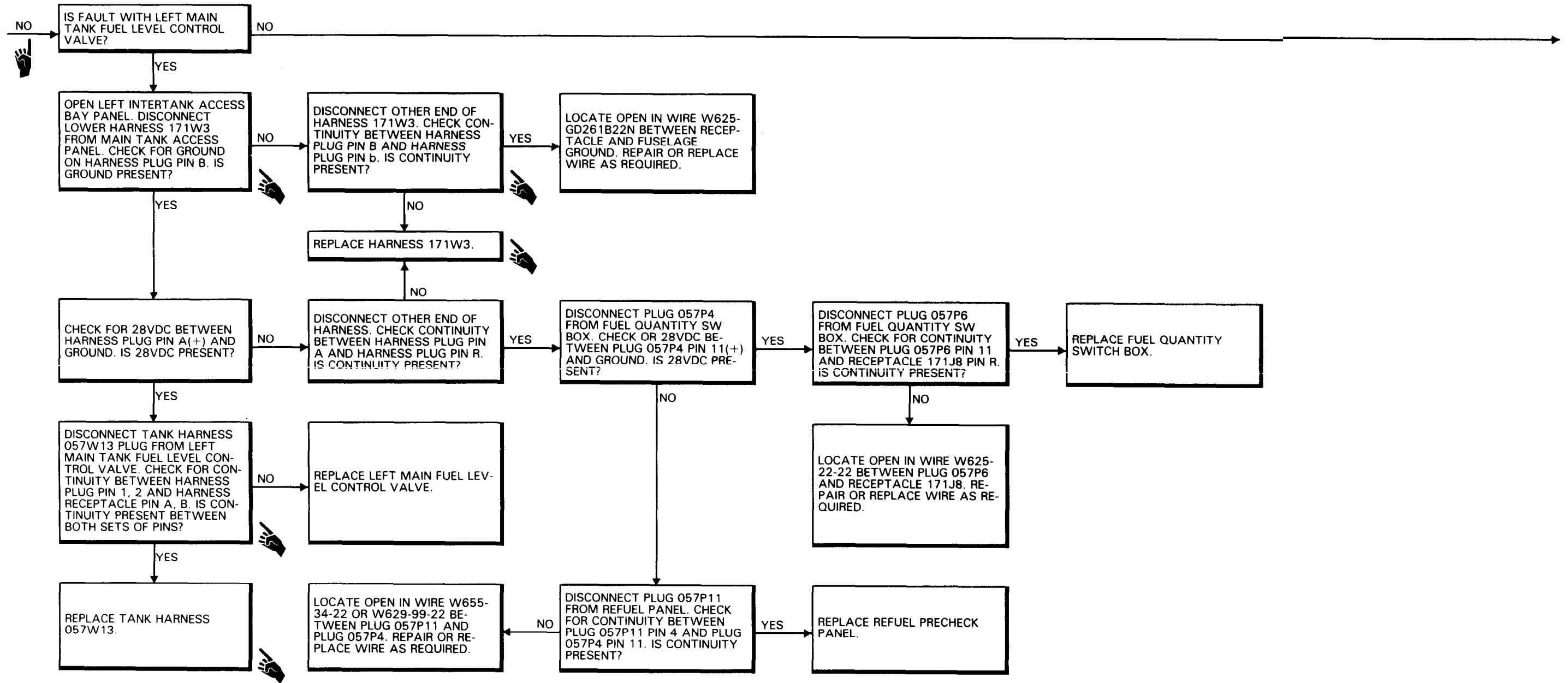

10-3.12 FUEL DOES NOT STOP FLOWING WITHIN
4 SECONDS WITH ALL TEST SWITCH
AT PRI OFF (Continued)

10-3.12

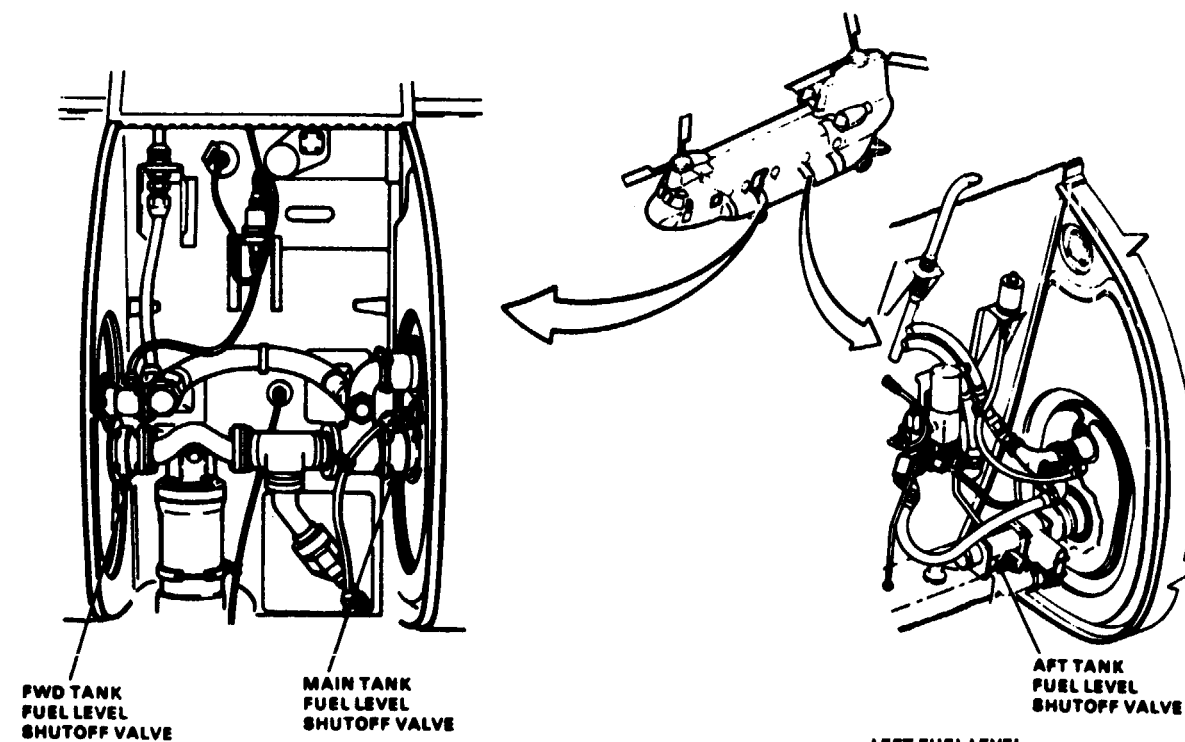

LEFT FUEL LEVEL SHUTOFF VALVES SHOWN. RIGHT FUEL LEVEL SHUTOFF VALVES SIMILAR.

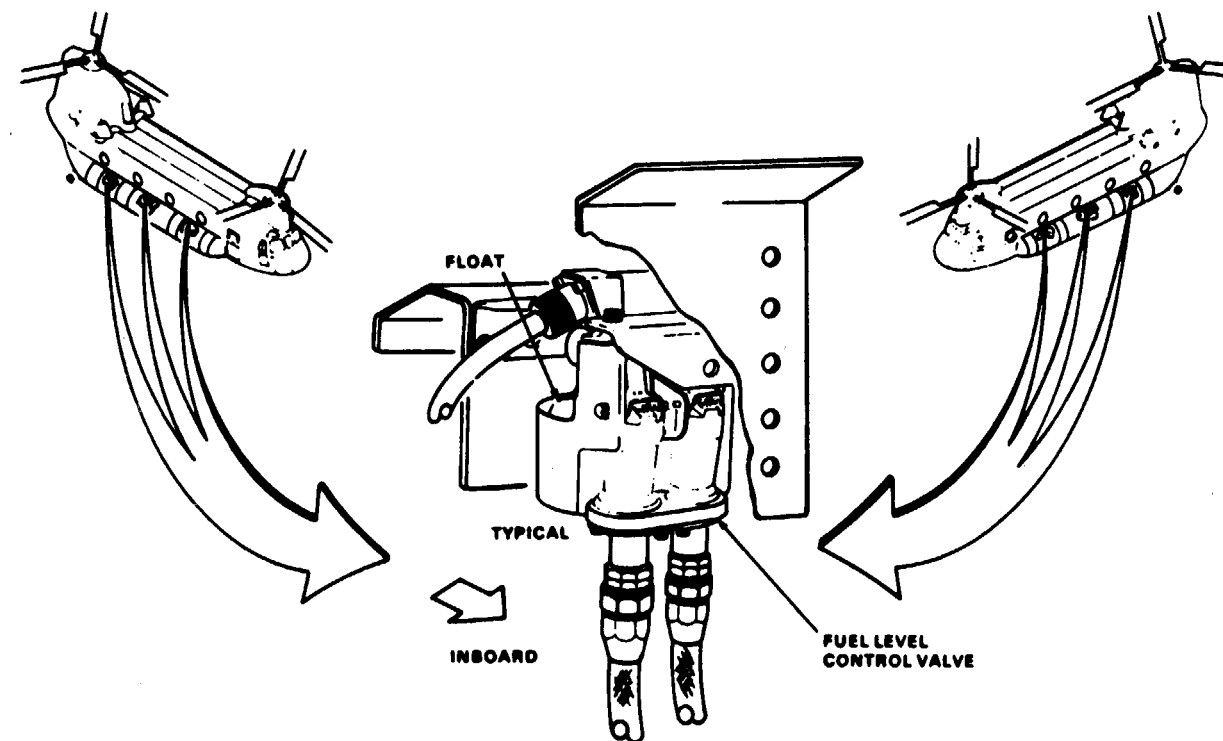
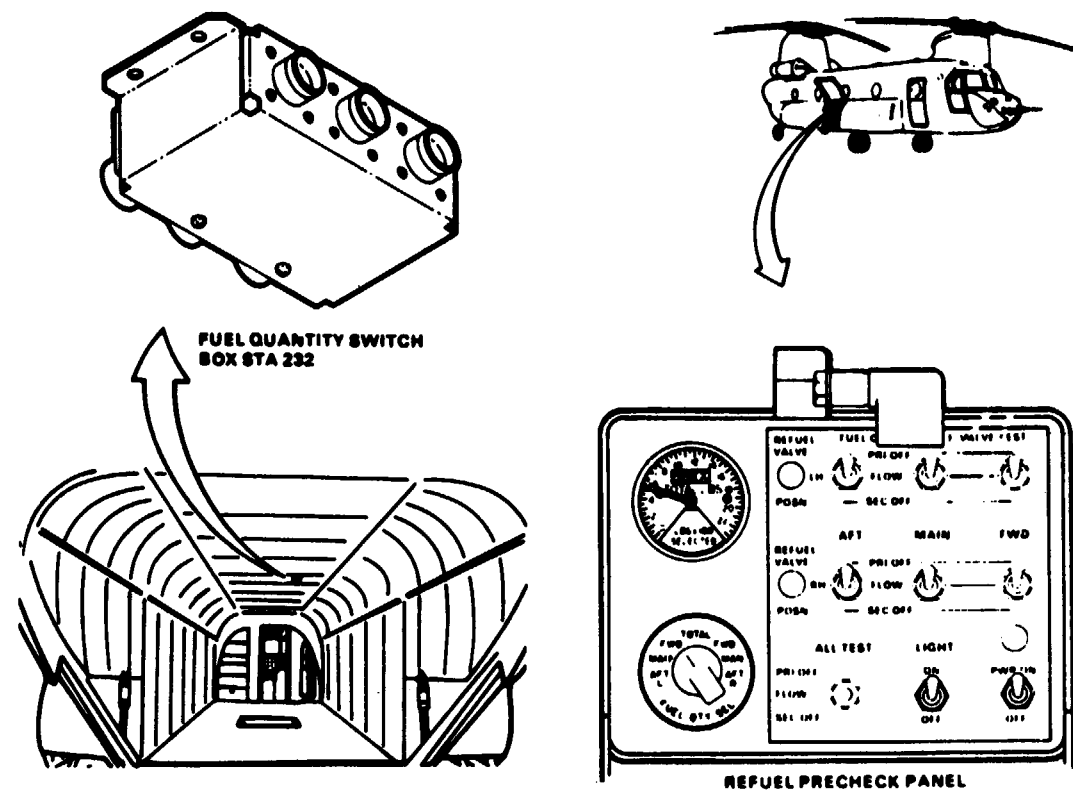

90 X 54

D143-11805-8PA

GO TO NEXT PAGE

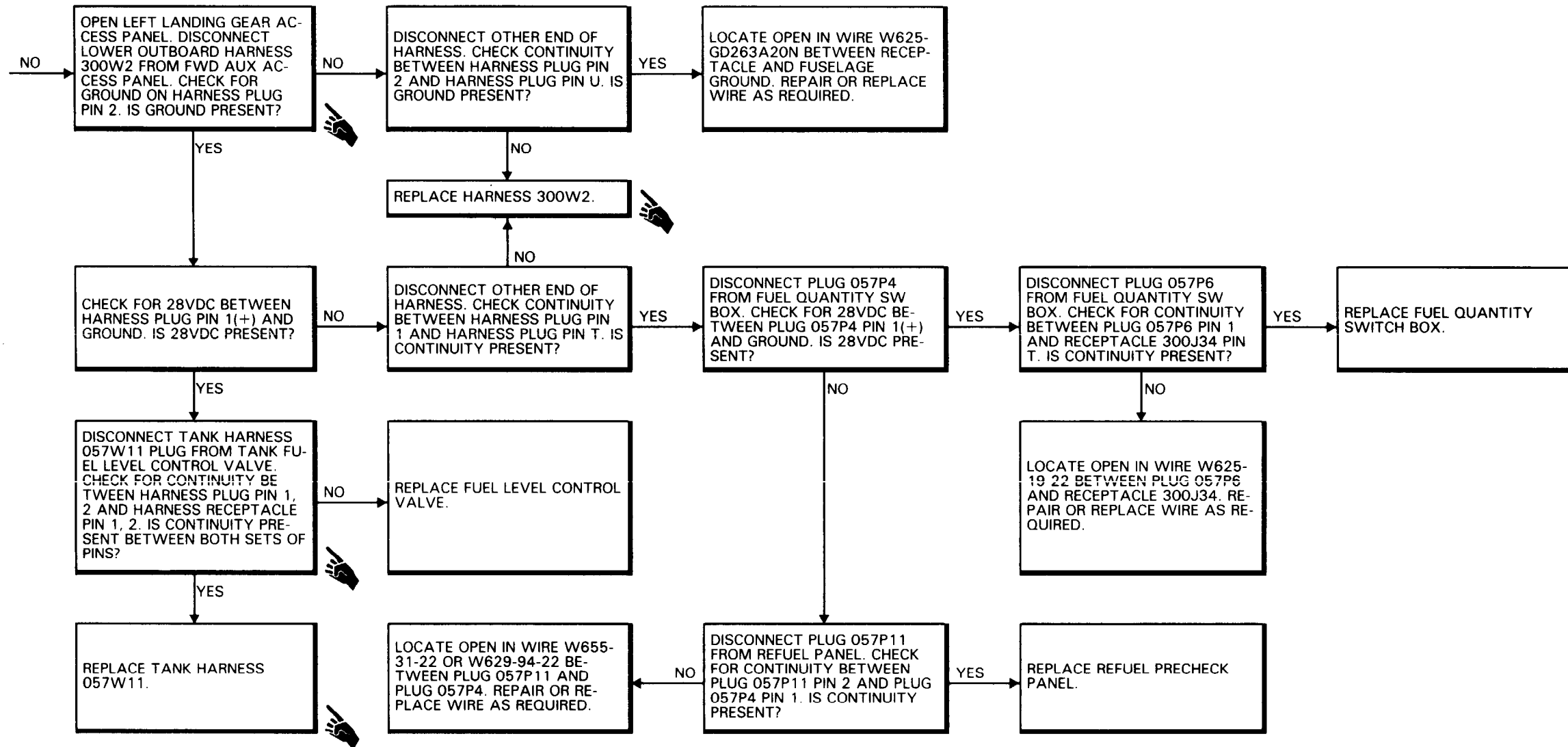

10-3.12 FUEL DOES NOT STOP FLOWING WITH IN
4 SECONDS WITH ALL TEST SWITCH
AT PRI OFF (Continued)

10-3.12

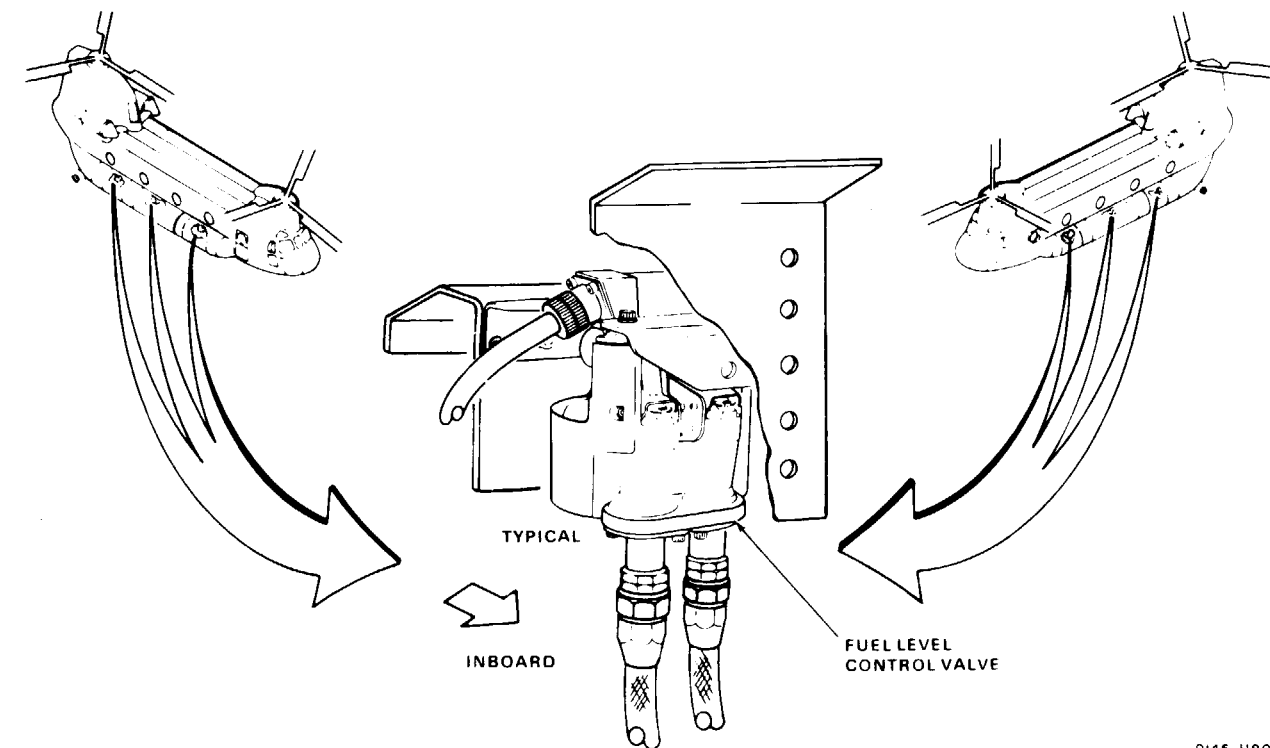
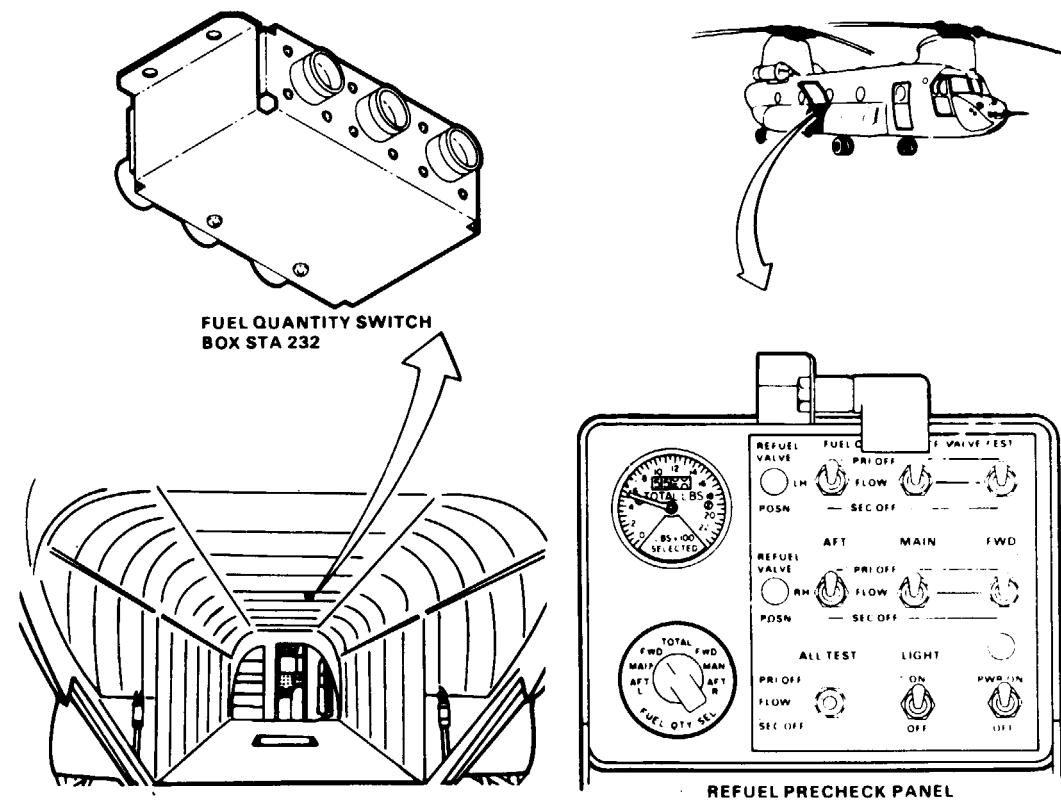
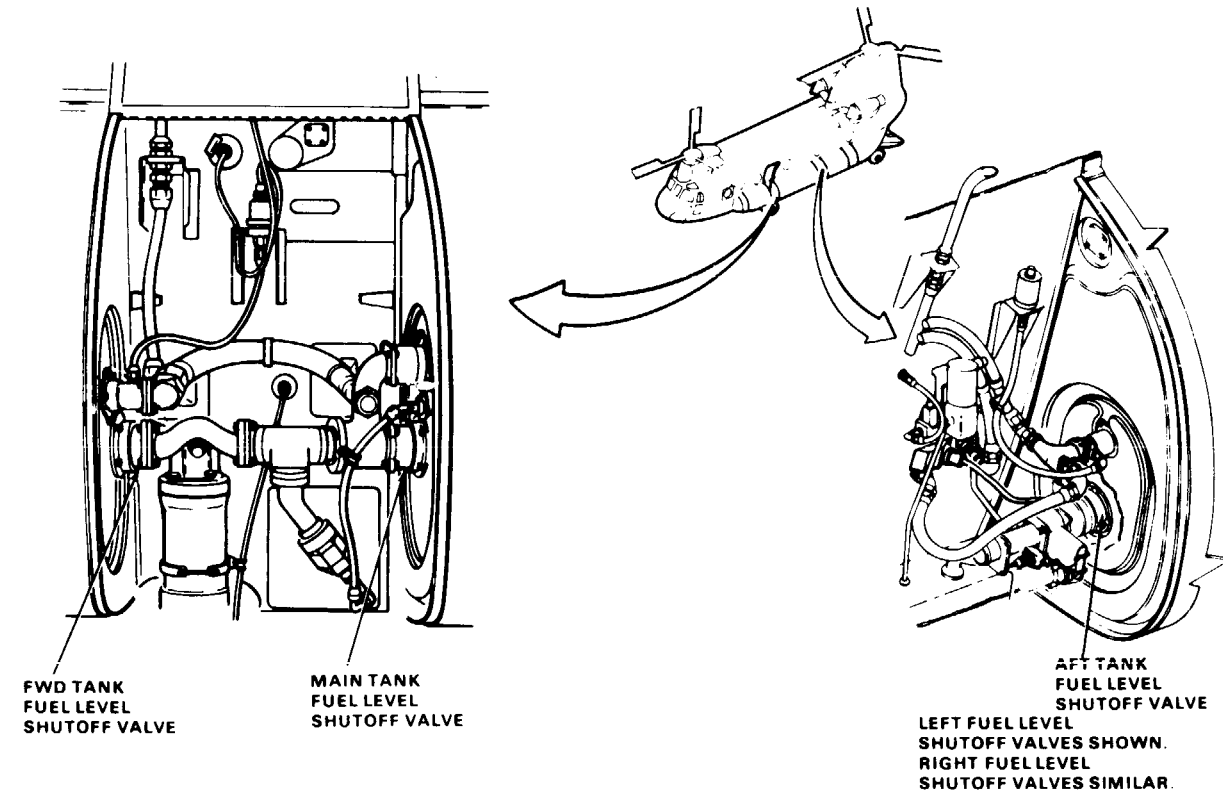

90X54

D145-11806-SPA

END OF TASK

10-165

10-3.13 FUEL DOES NOT STOP FLOWING WITHIN 4 SECONDS WITH ALL TEST SWITCH AT SEC OFF

FAULT ISOLATION PROCEDURE

INITIAL STUP

Applicable Configurations:

All

Tools:

- Electrical Repairer's Tool Kit, NSN 5180-00-323-4915
- Aircraft Mechanic's Tool Kit, NSN 5180-00-323-4692
- Multimeter

Materials:

None

Personnel Required:

- 67U20 Medium Helicopter Repairer
- 68F20 Aircraft Electrician

References:

TM 55-1520-240-23

Equipment Condition:

- TM 55-1520-240-23:
- Battery Connected
- Aircraft Being Refueled
- Hydraulic Power Off

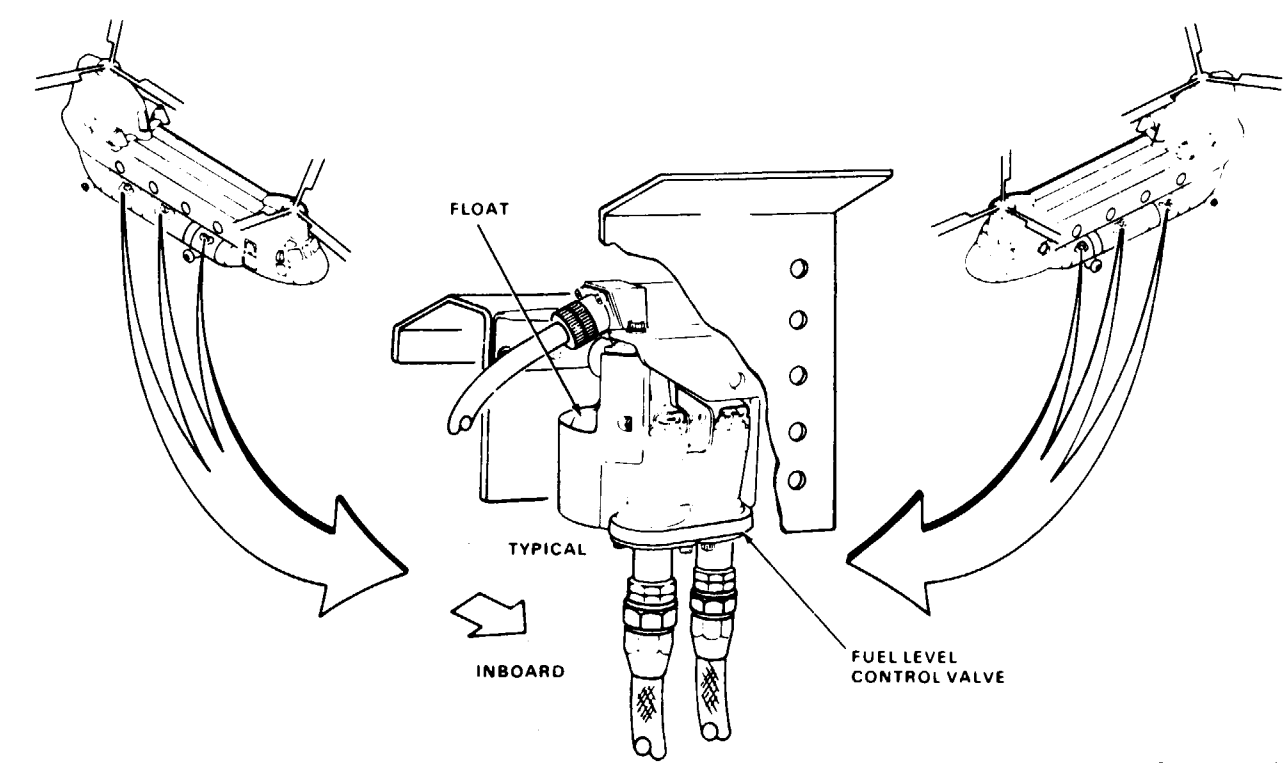
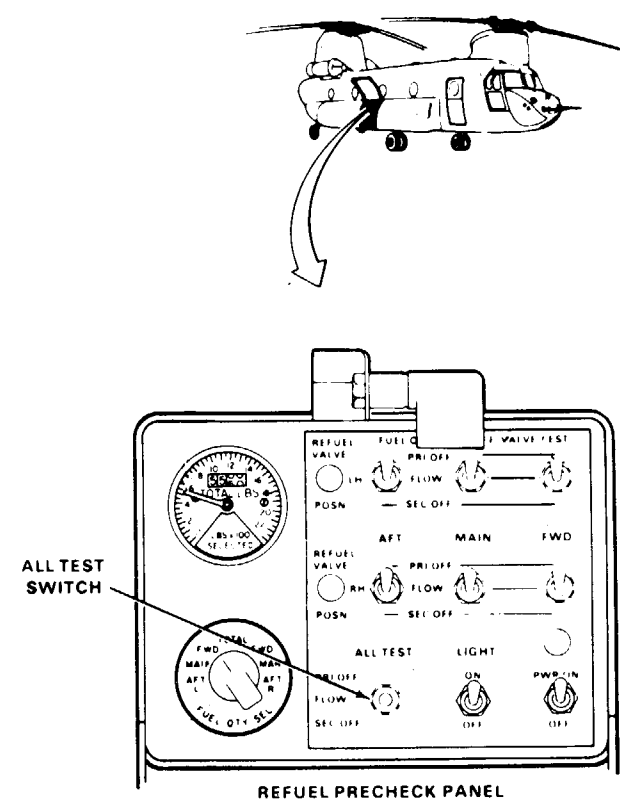
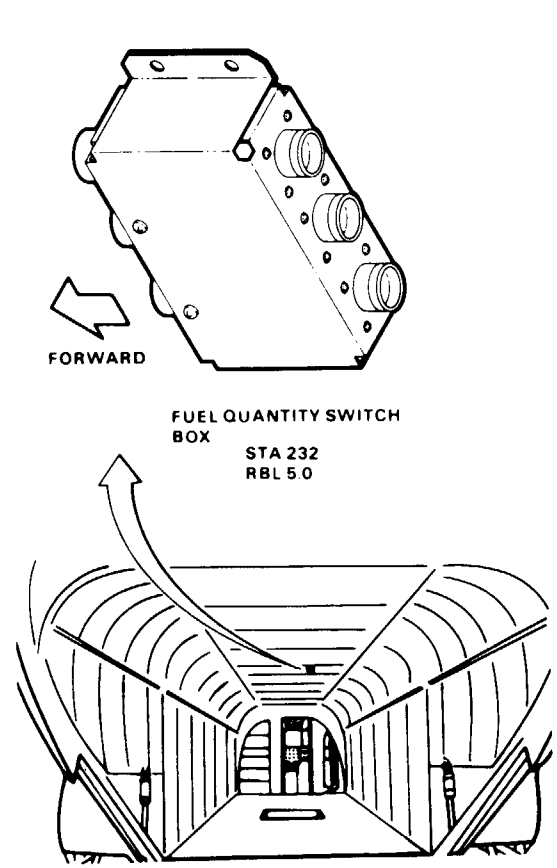
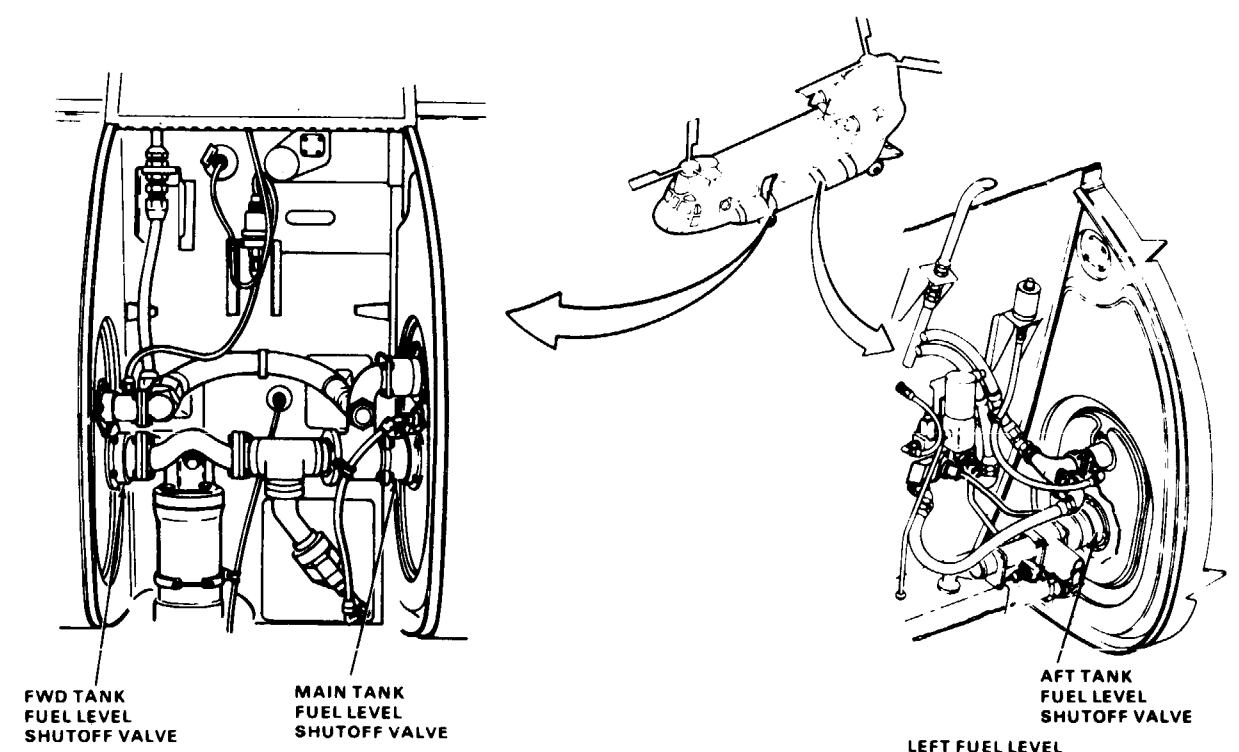

90X54

D145-11807-SPA

10-3.13 FUEL DOES NOT STOP FLOWING WITHIN 4 SECONDS WITH ALL TEST SWITCH AT SEC OFF
(Continued)

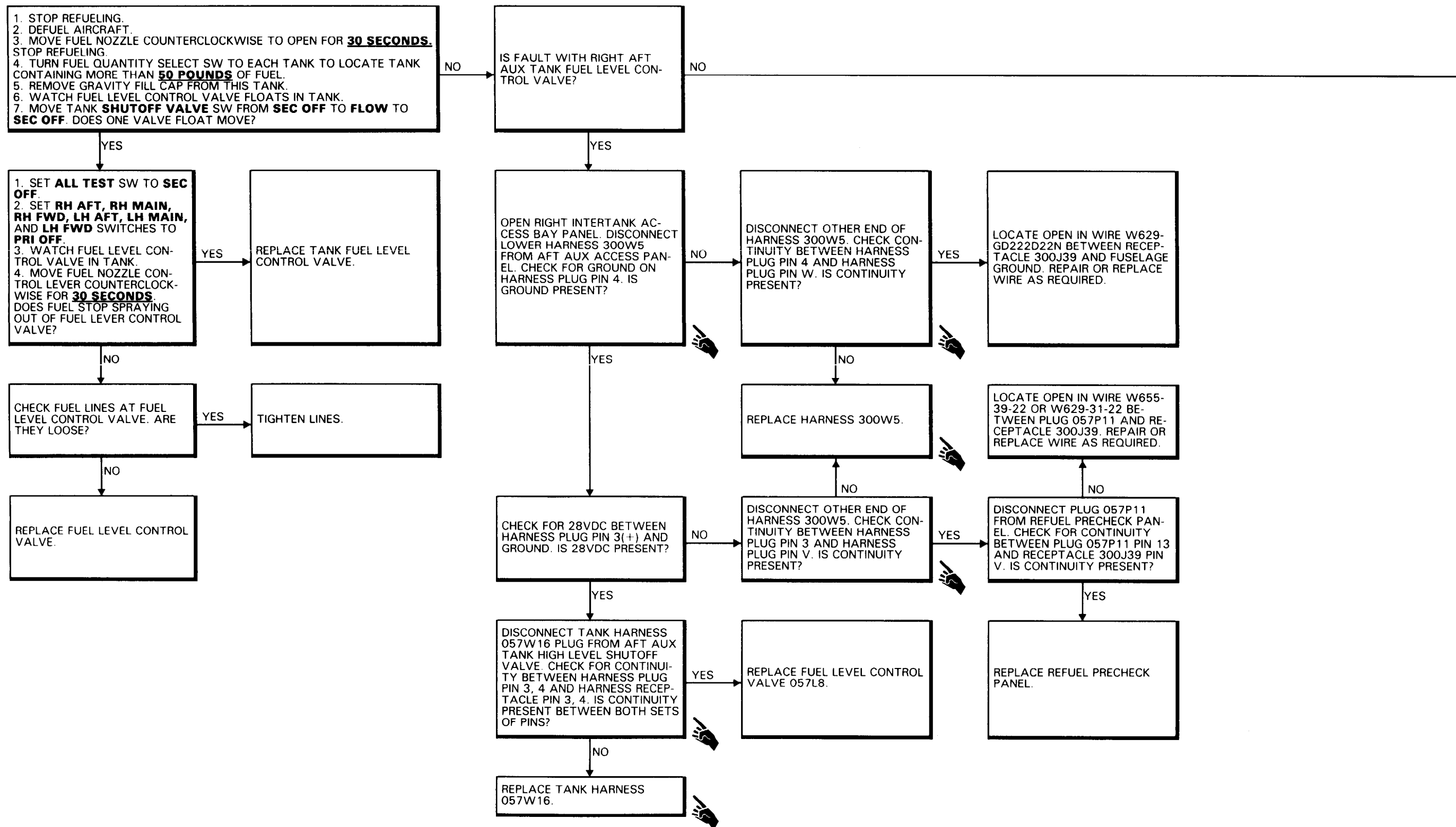

(Continued)

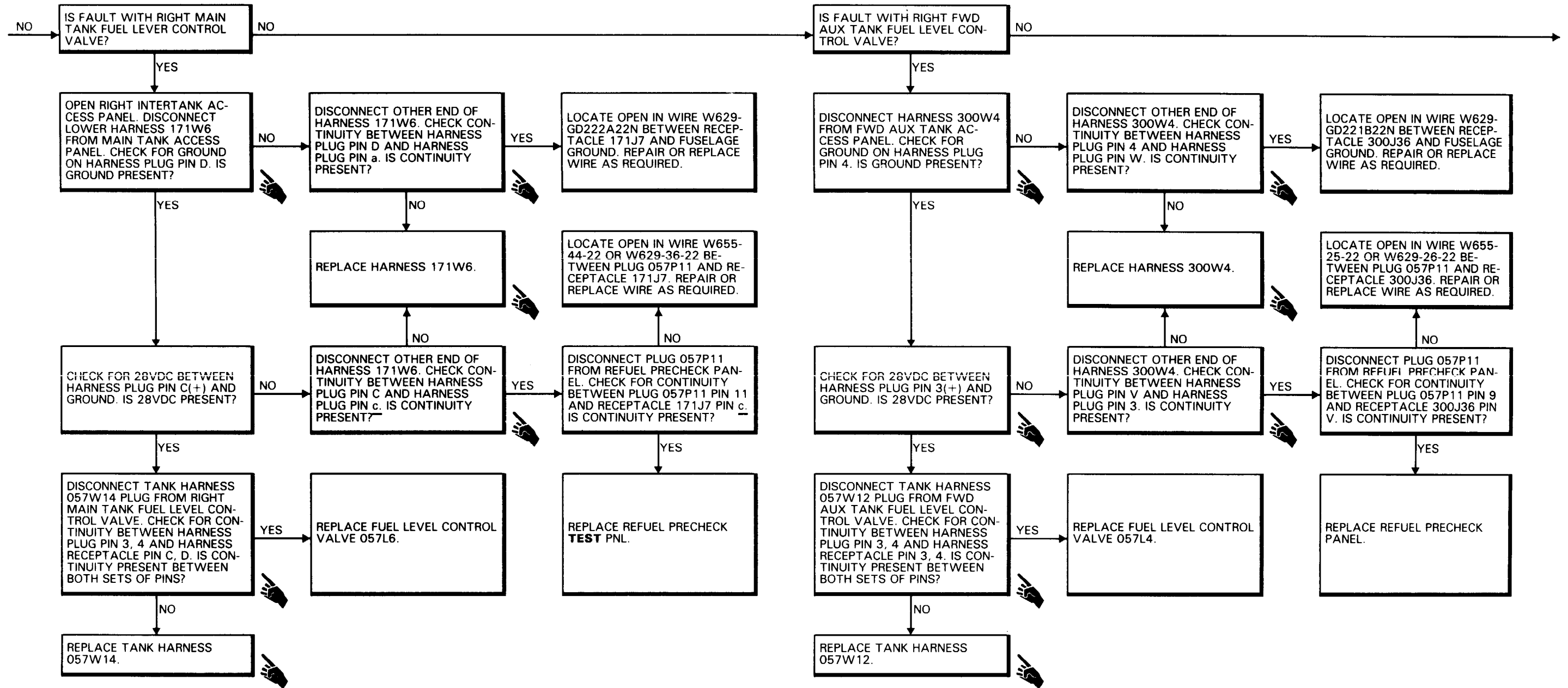

10-3.13 FUEL DOES NOT STOP FLOWING WITHIN 4 SECONDS WITH ALL TEST SWITCH AT SEC OFF (Continued)

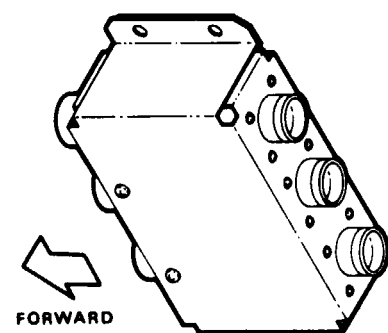

FUEL QUANTITY SWITCH BOX STA 232 RBL 5.0

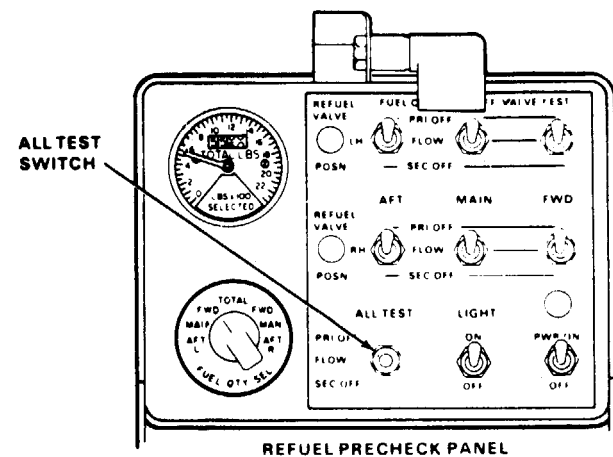
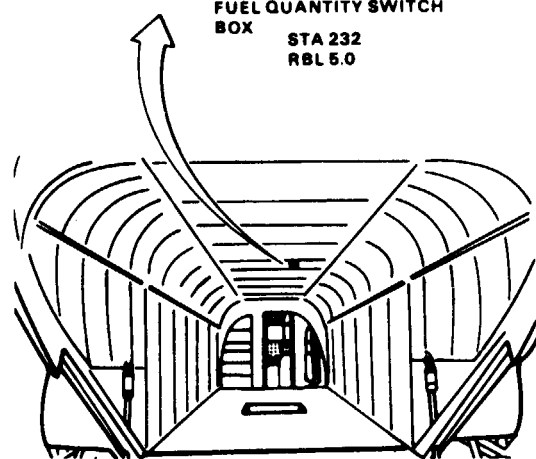

REFUEL PRECHECK PANEL

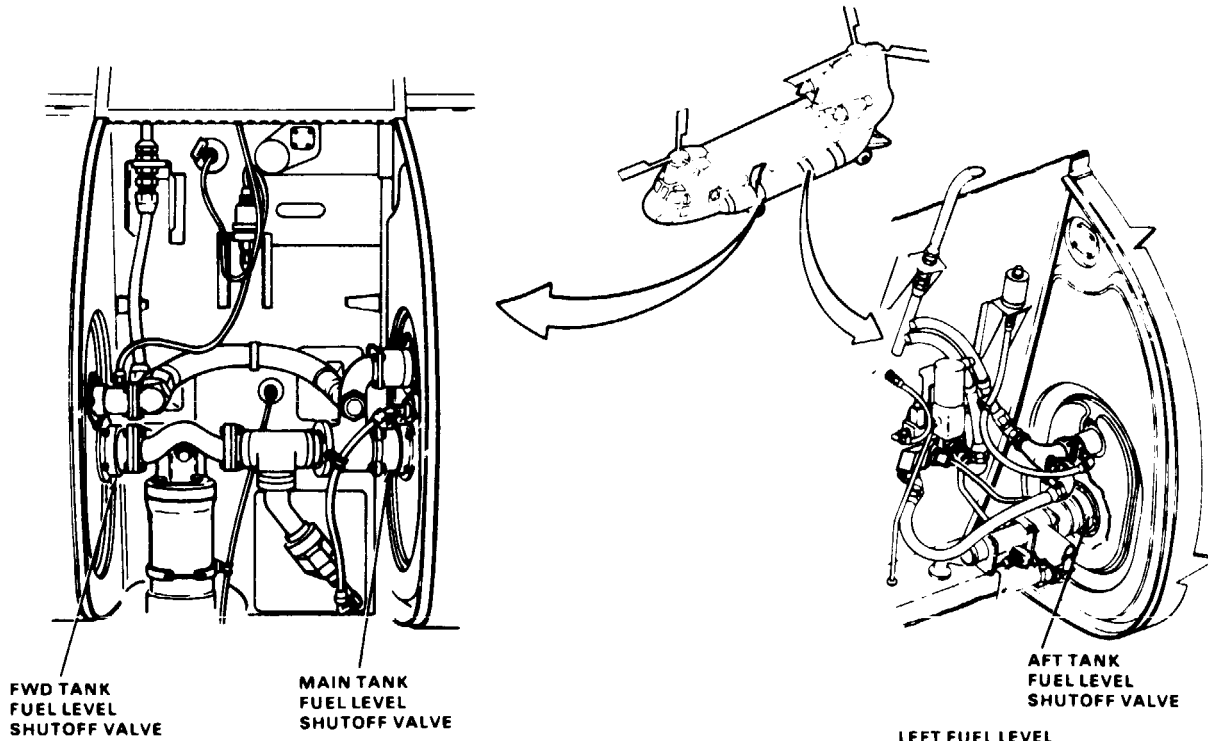

FWD TANK FUEL LEVEL SHUTOFF VALVE

MAIN TANK FUEL LEVEL SHUTOFF VALVE

AFT TANK FUEL LEVEL SHUTOFF VALVE

LEFT FUEL LEVEL SHUTOFF VALVES SHOWN. RIGHT FUEL LEVEL SHUTOFF VALVES SIMILAR.

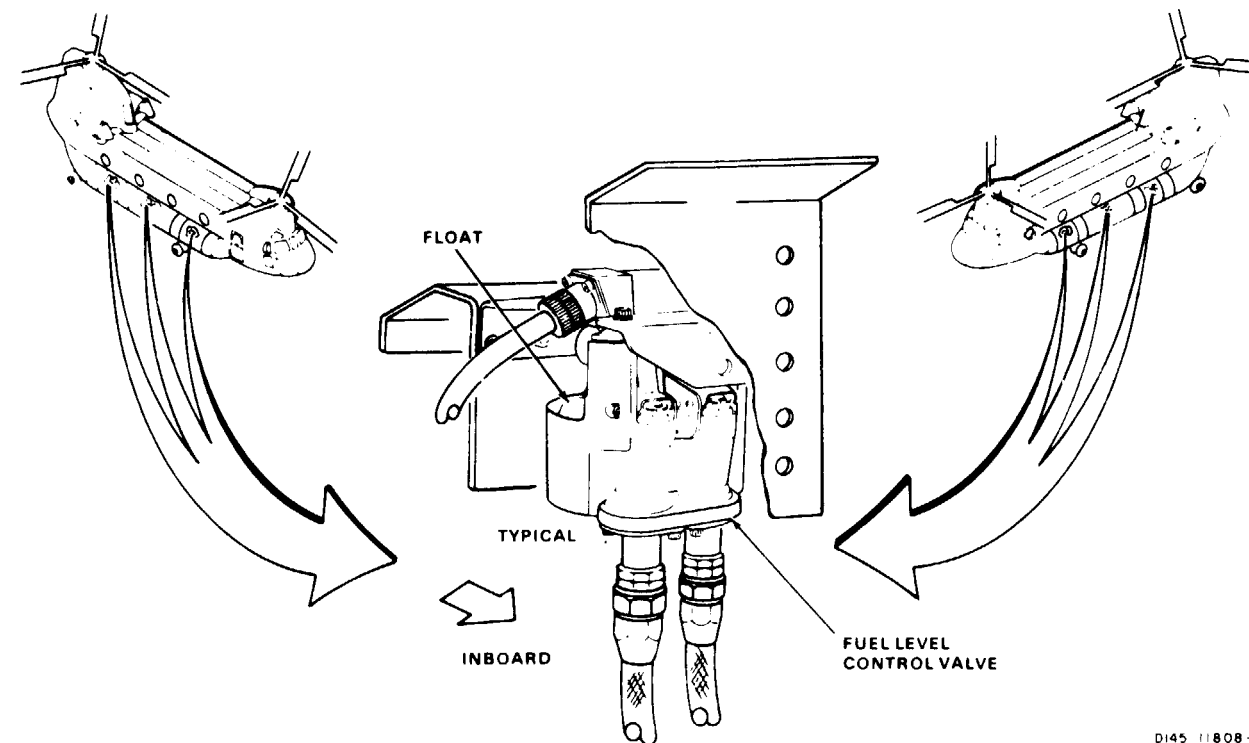

FLOAT

TYPICAL

INBOARD

FUEL LEVEL CONTROL VALVE

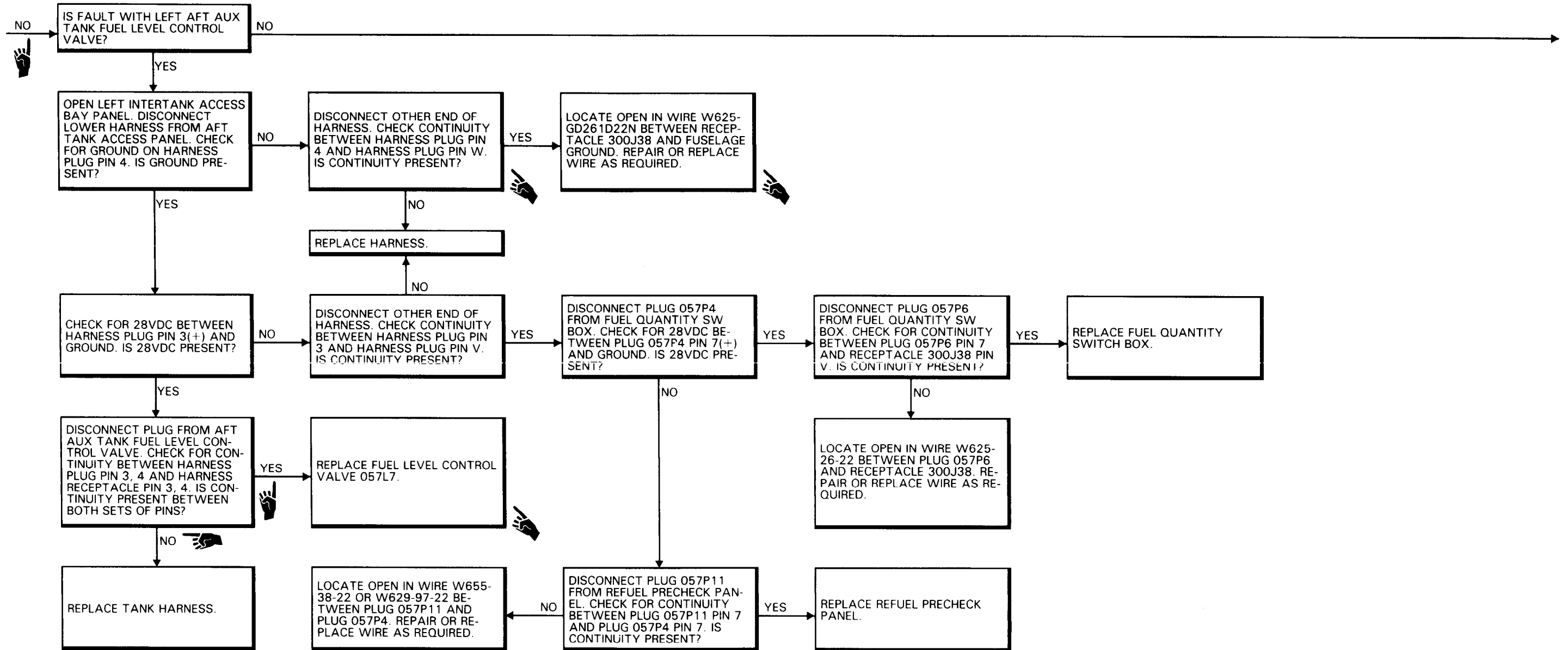

10-3.13 FUEL DOES NOT STOP FLOWING WITHIN 4 SECONDS WITH ALL TEST SWITCH AT SEC OFF (Continued)

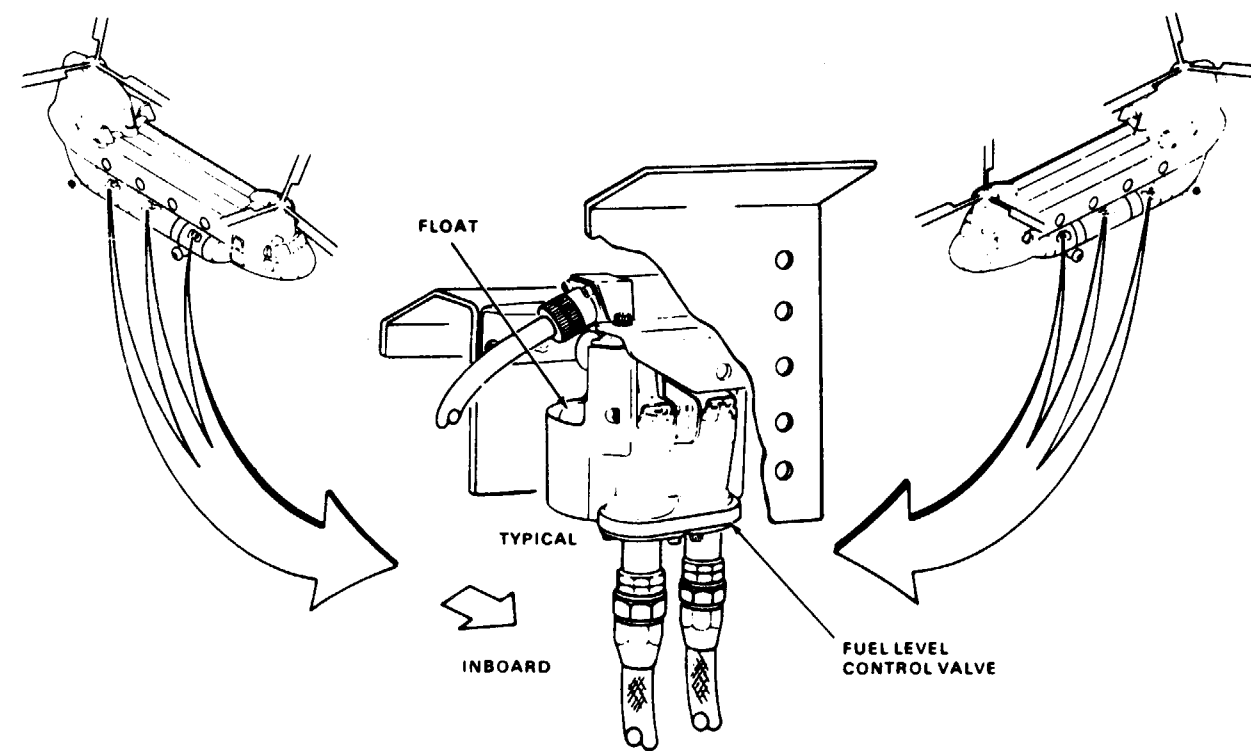
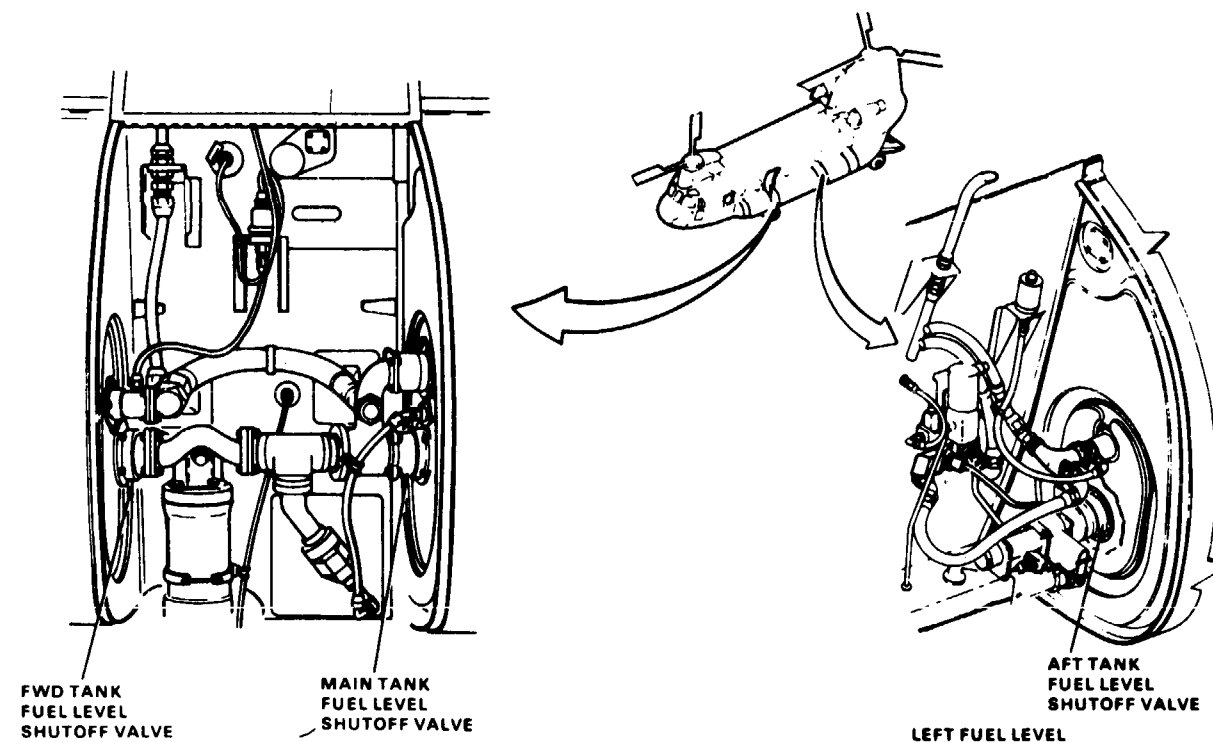
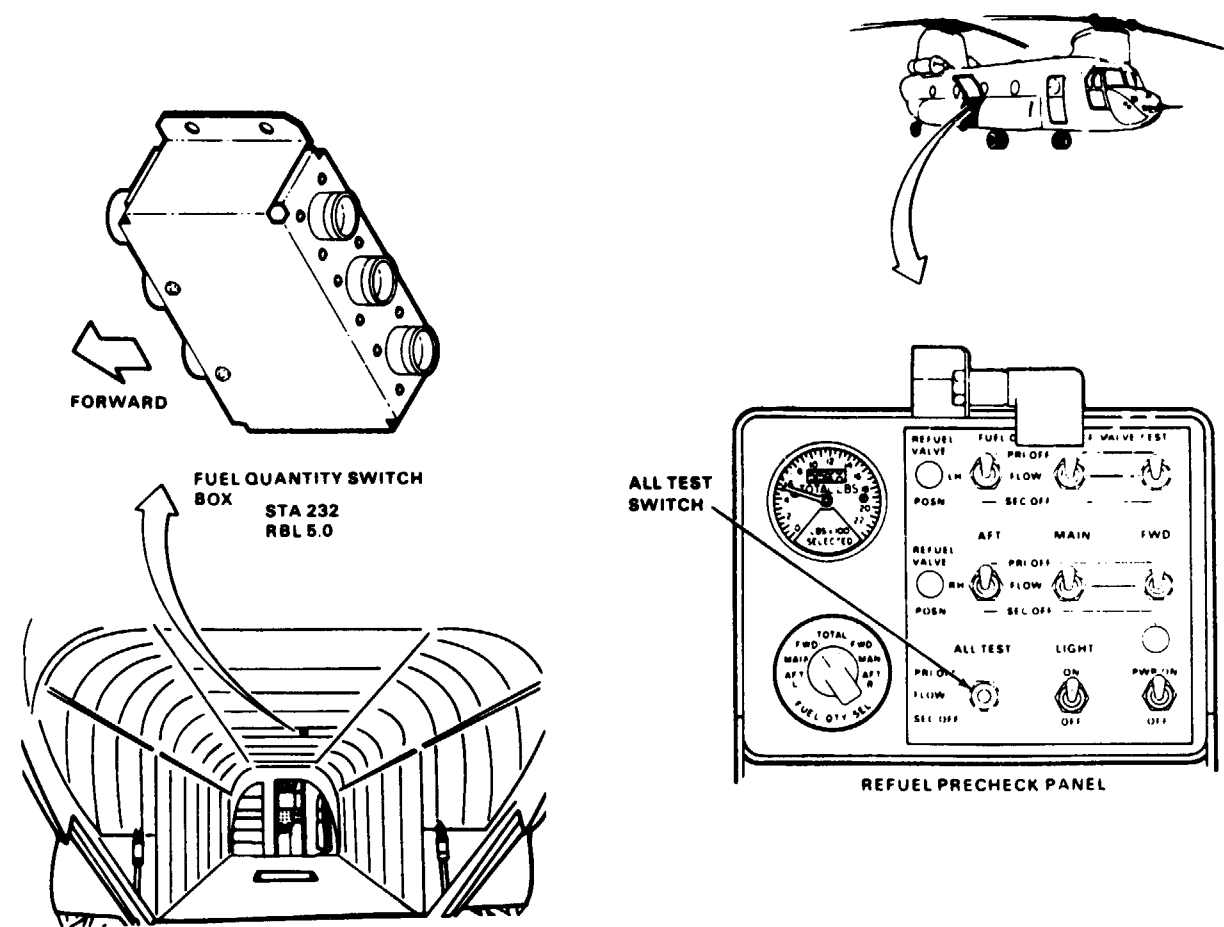

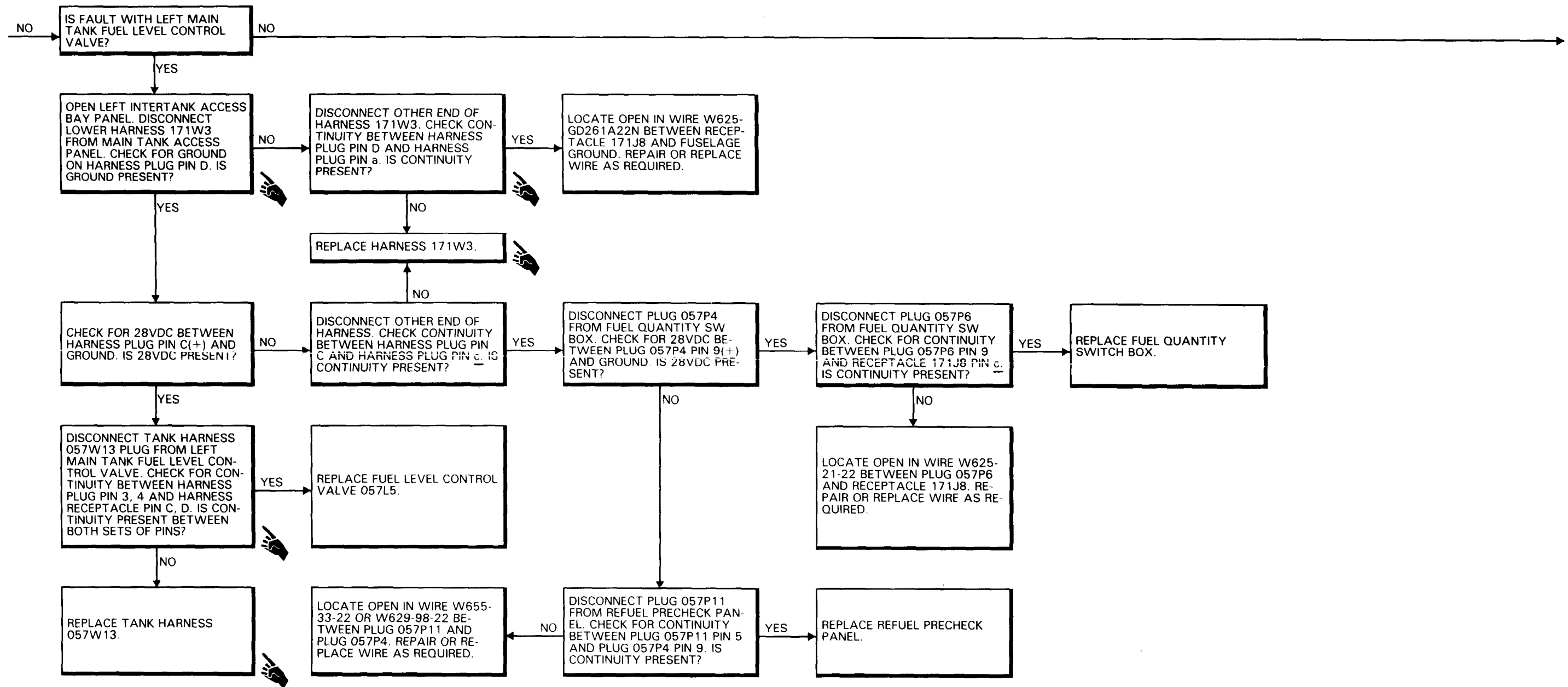

10-3.13 FUEL DOES NOT STOP FLOWING WITHIN 4 SECONDS WITH ALL TEST SWITCH AT SEC OFF (Continued)

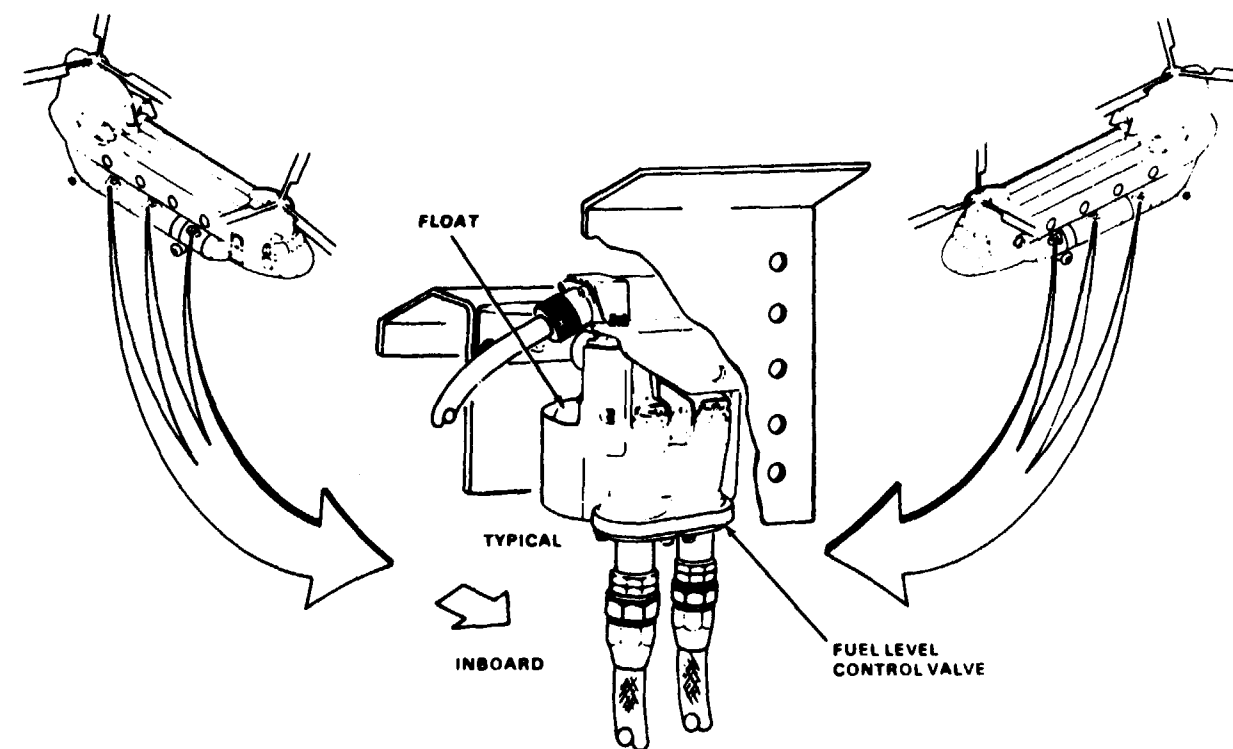
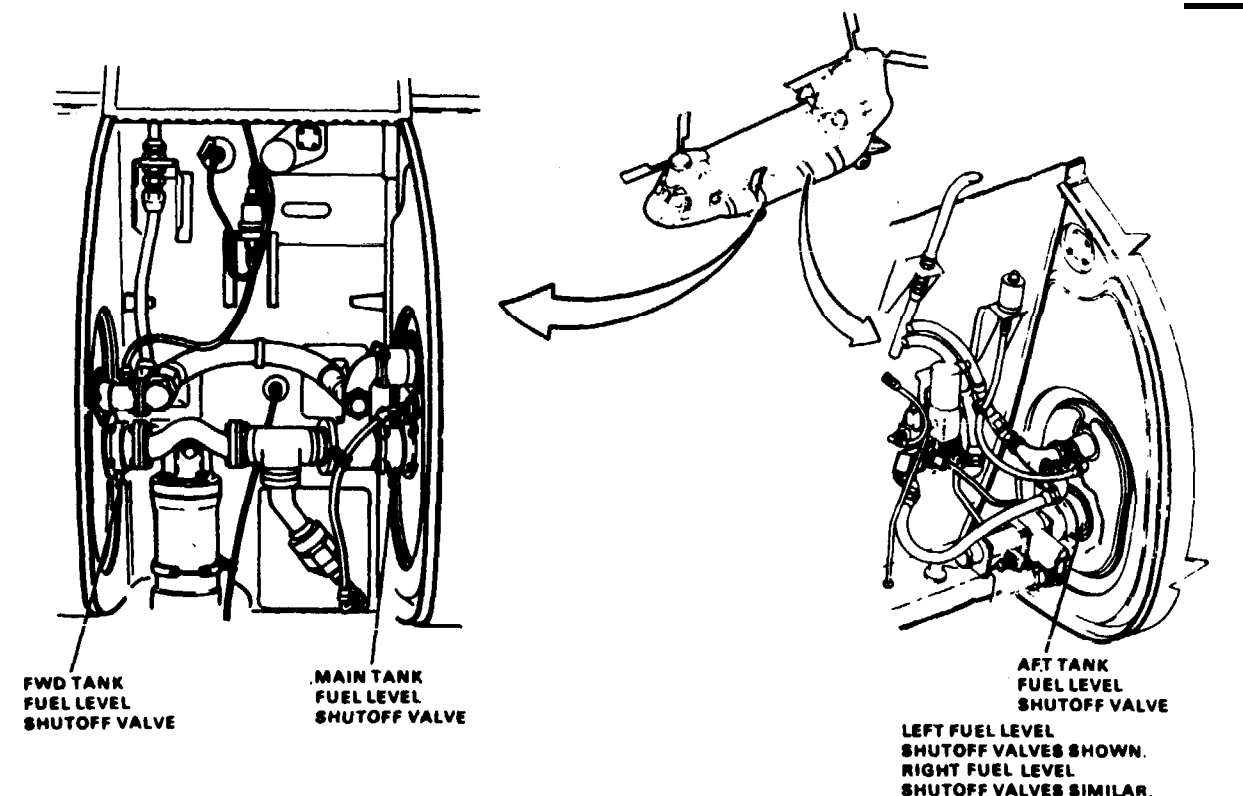
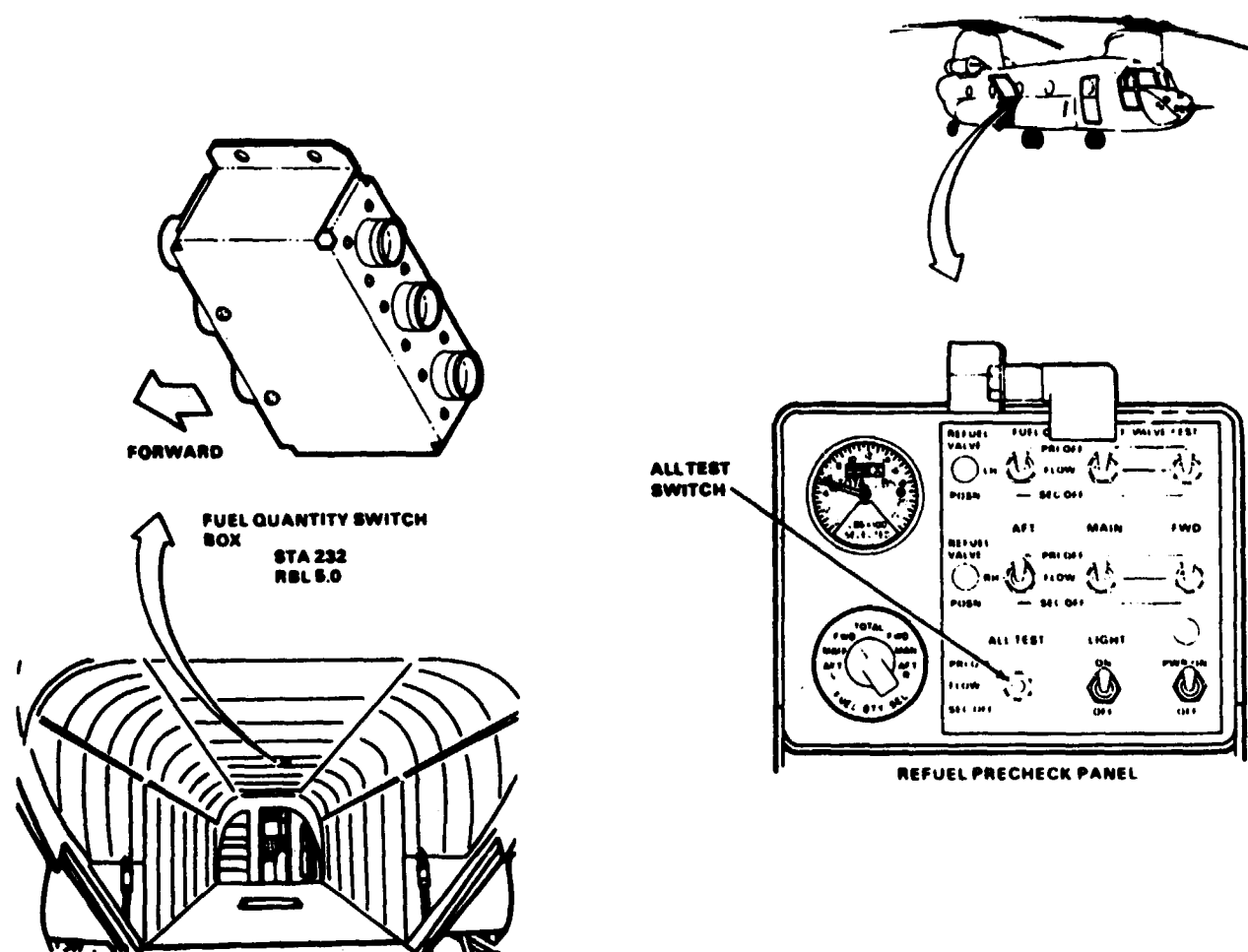

90194

D145-11810-SPA

GO TO NEXT PAGE

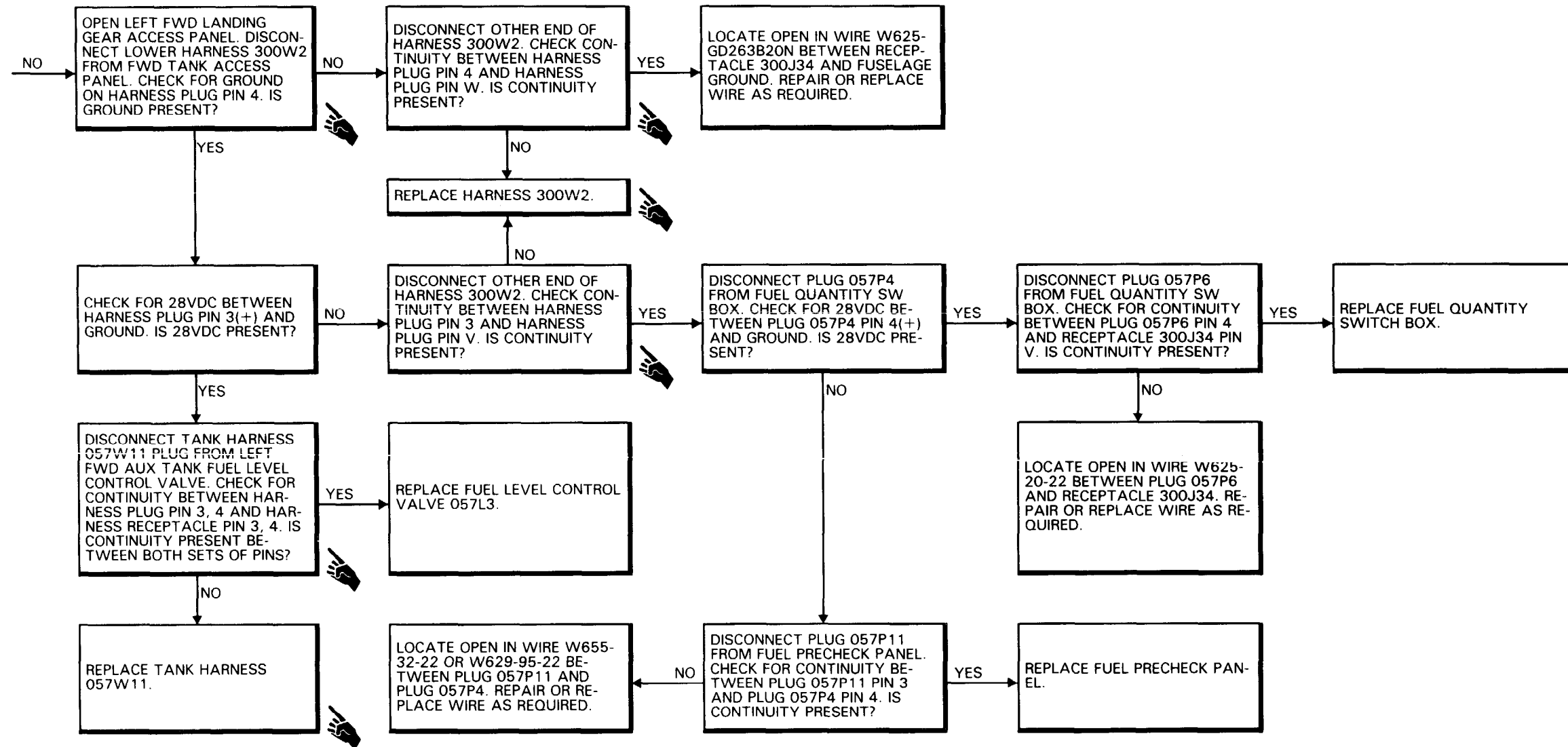

10-3.13 FUEL DOES NOT STOP FLOWING WITHIN 4 SECONDS WITH ALL TEST SWITCH AT SEC OFF (Continued)

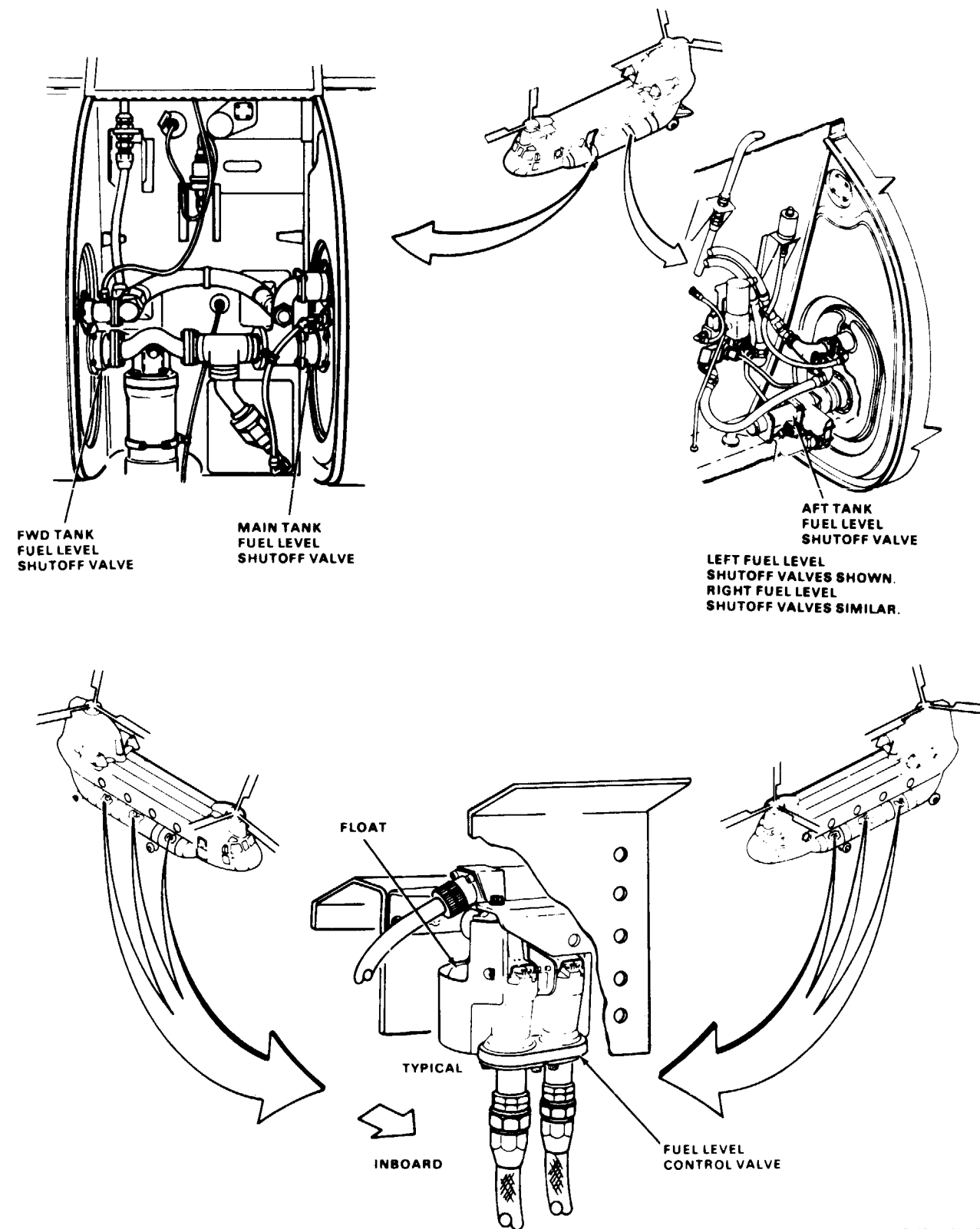
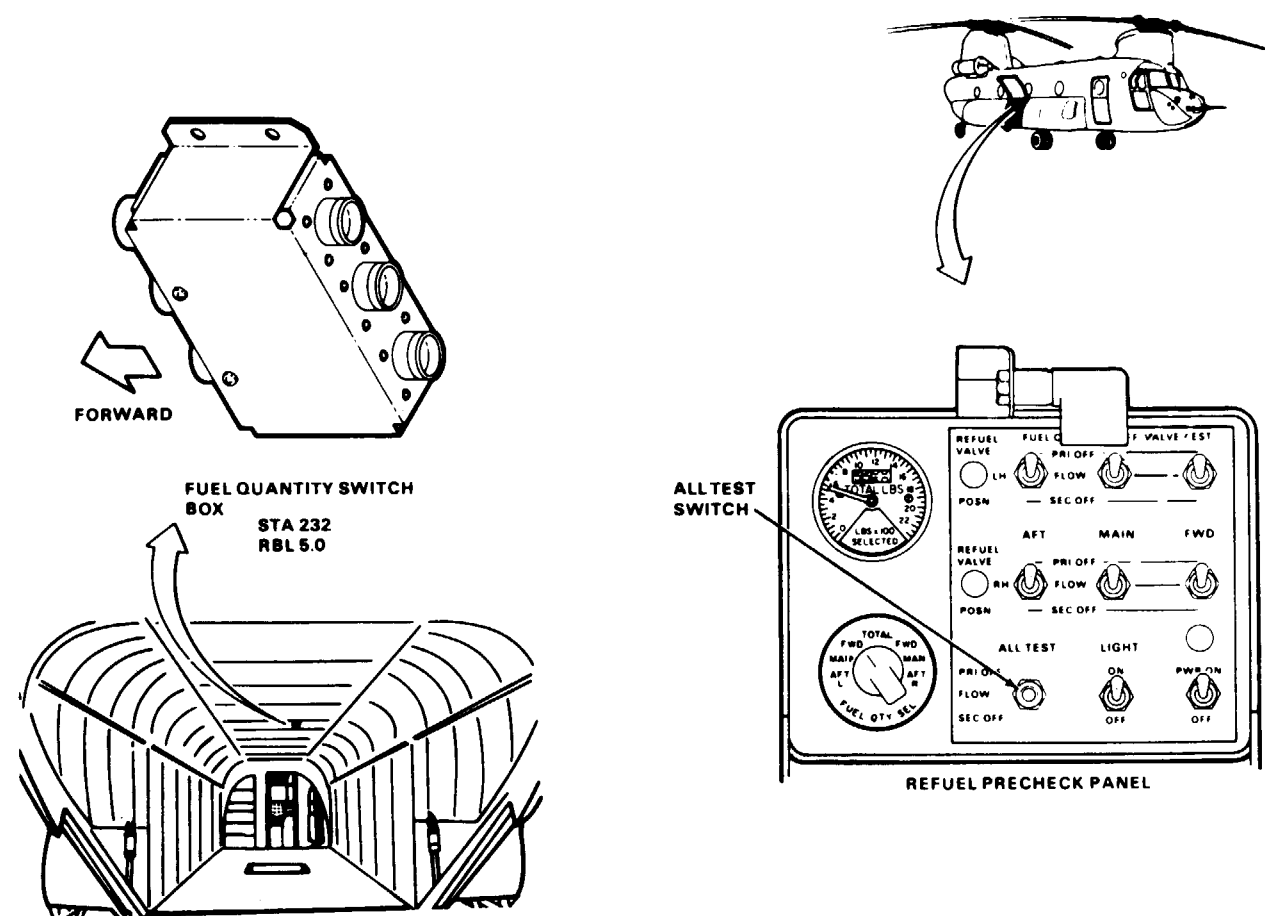

10-3.14 TANK WILL NOT ACCEPT FUEL WHILE PRESSURE REFUELING

FAULT ISOLATION PROCEDURE

INITIAL SETUP

Applicable Configurations:
All

Tools:
Electrical Repairer's Tool Kit,
NSN 5180-00-323-4915
Aircraft Mechanic's Tool Kit,
NSN 5180-00-323-4692
Multimeter

Materials:
None

Personnel Required
Medium Helicopter Repairer
Aircraft Electrician

References:
TM 55-1520-240-23

Equipment Condition:
TM 55-1520-240-23:
Battery Connected
Electrical Power On
Hydraulic Power Off
Aircraft Being Refueled

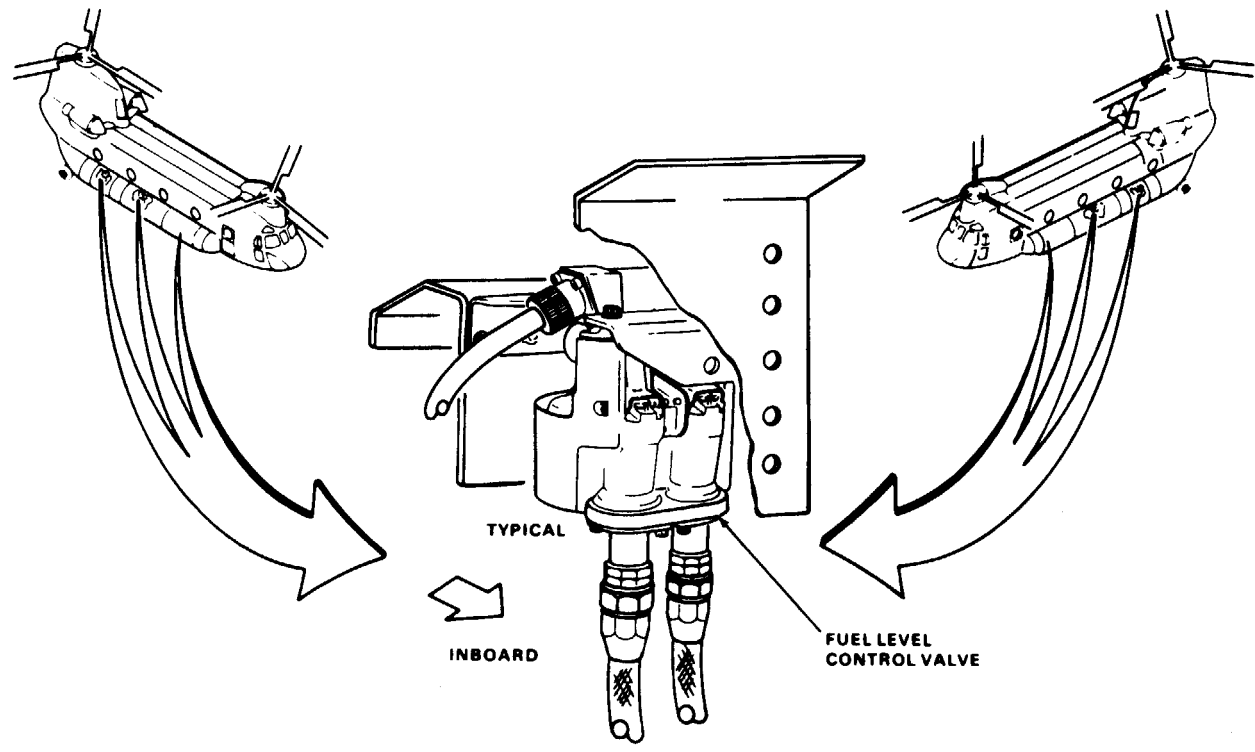
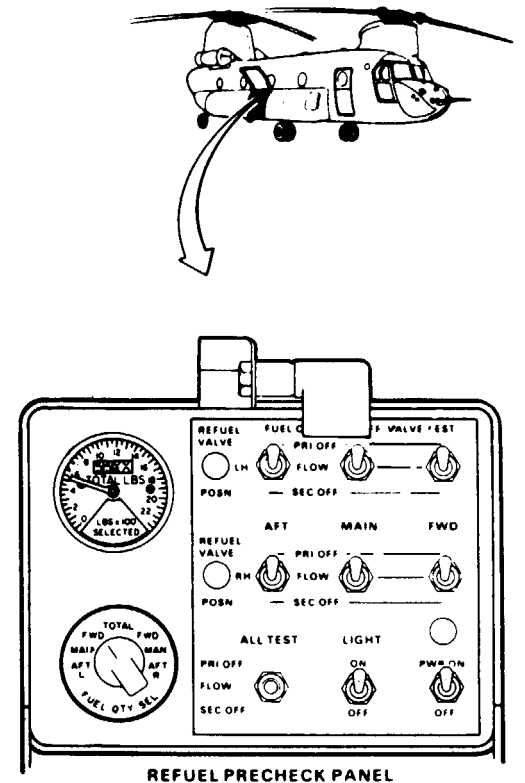
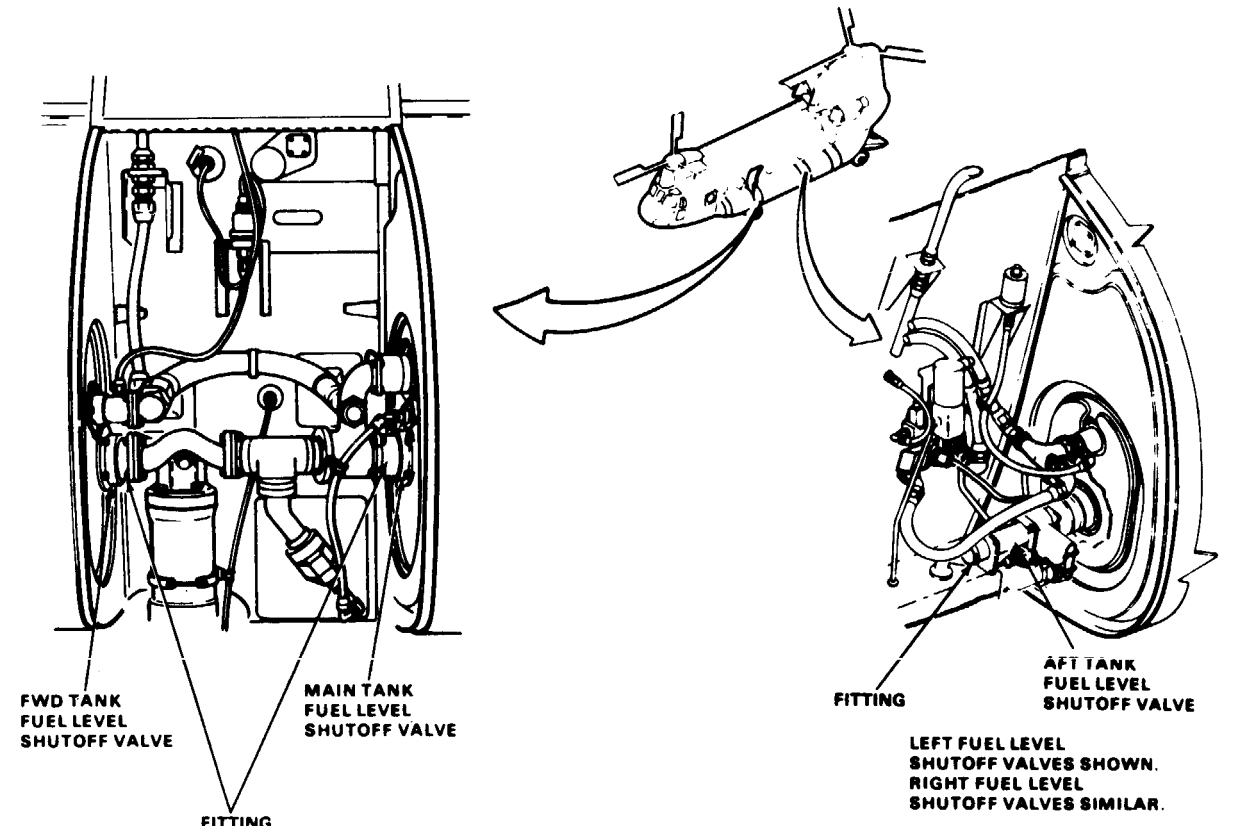

10-3.14 TANK WILL NOT ACCEPT FUEL WHILE PRESSURE REFUELING (Continued)

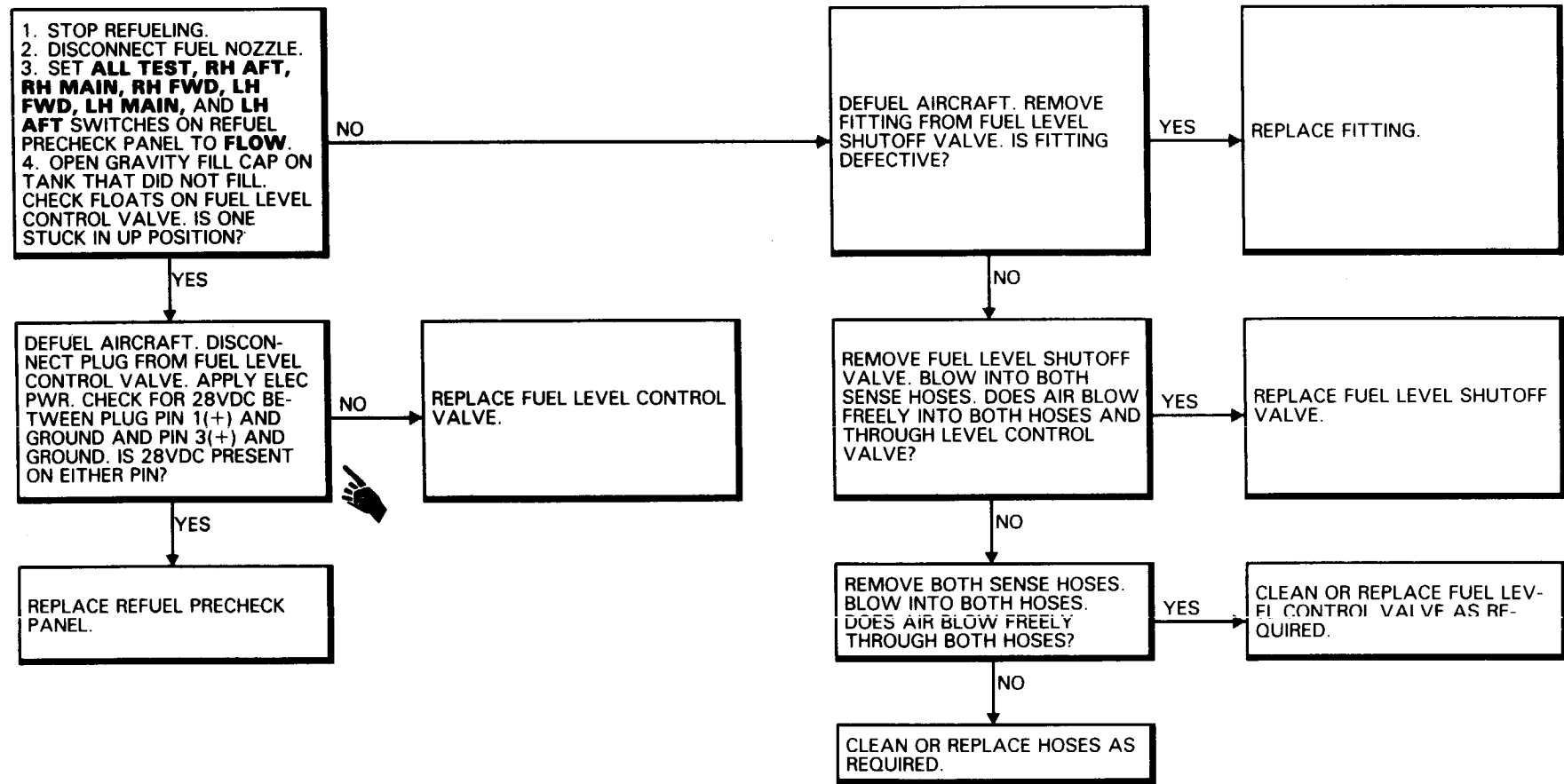

SECTION 10-4 EXTENDED RANGE FUEL SYSTEM (ERFS II) (WITH 82)



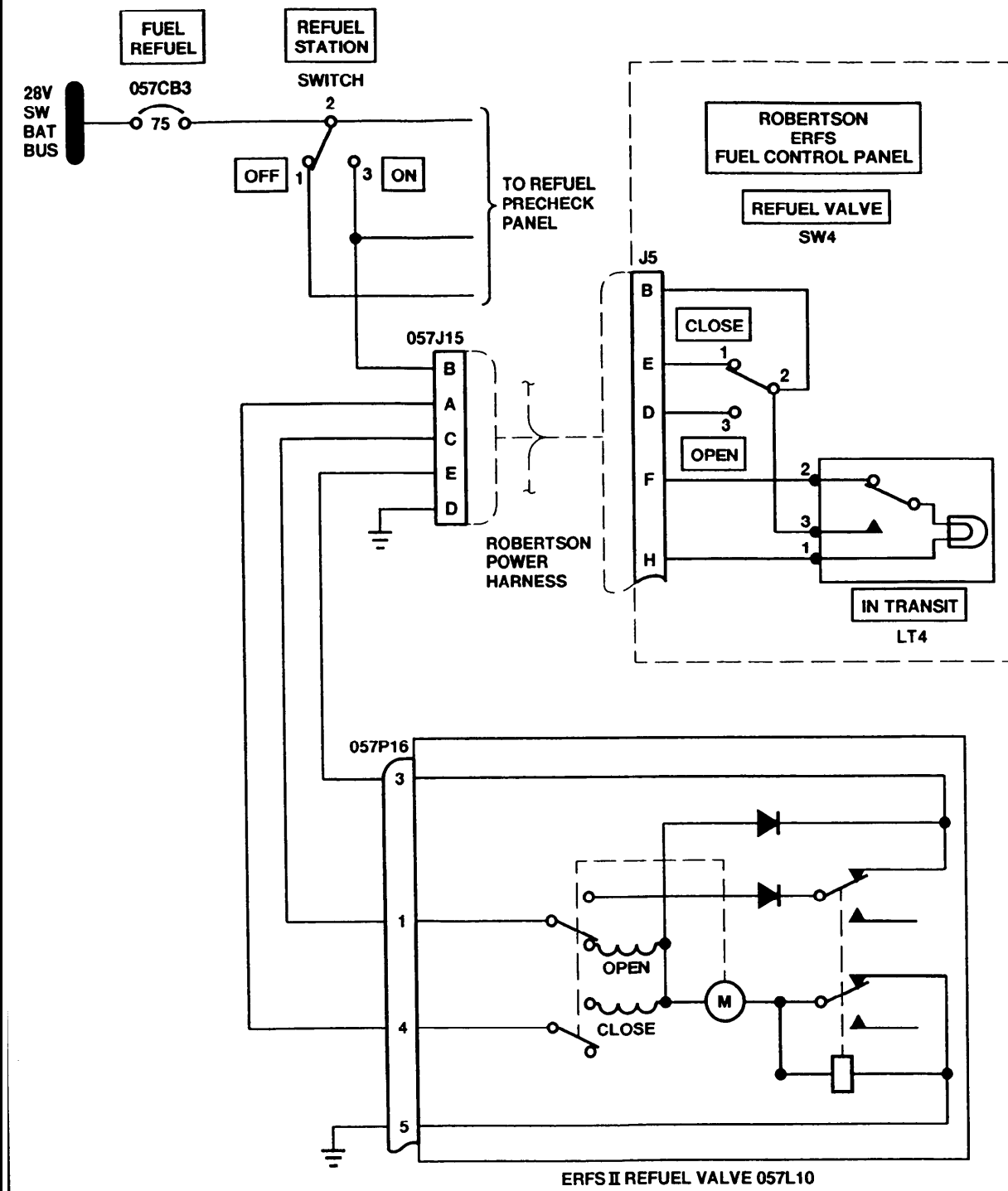

A73207

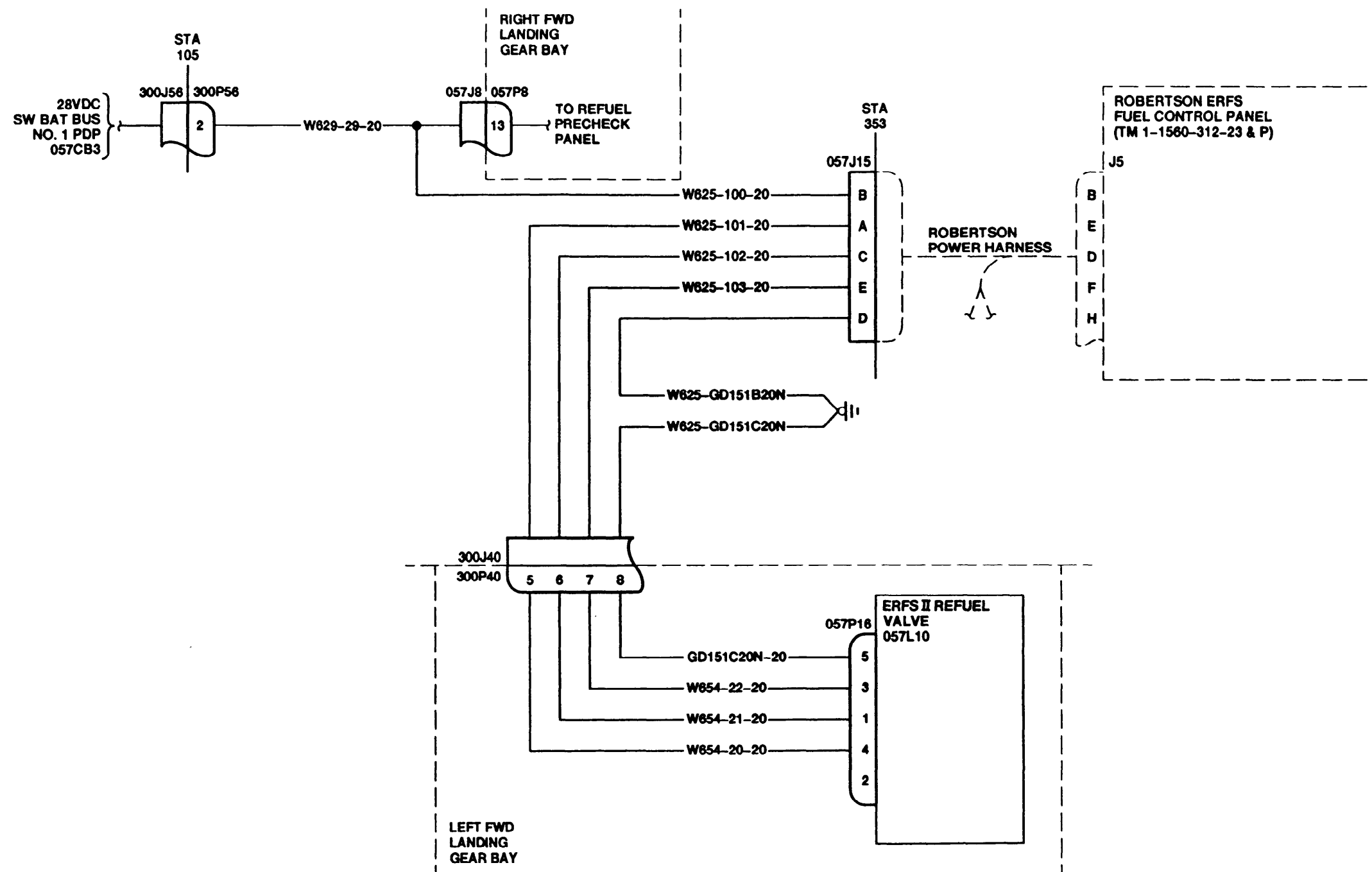

A73208

INITIAL SETUP

Applicable Configurations:

With **82**

Tools:

Electrical Repairer's Tool Kit,
NSN 5180-00-323-4915

Materials:

None

Personnel Required:

Aircraft Electrician

References:

TM 55-1520-240-23

Equipment Condition:

TM 55-1520-240-23:
Electrical Power Off
Battery Disconnected
Hydraulic Power Off
Forward Left Landing Gear Access Panel Open

TASK	RESULT
1. Check ERFS II refuel valve (1).	If valve (1) is loose or damaged, tighten or replace it as required. If wiring or connector (2) is damaged, repair or replace wiring or connector as required.

FOLLOW-ON MAINTENANCE:

None

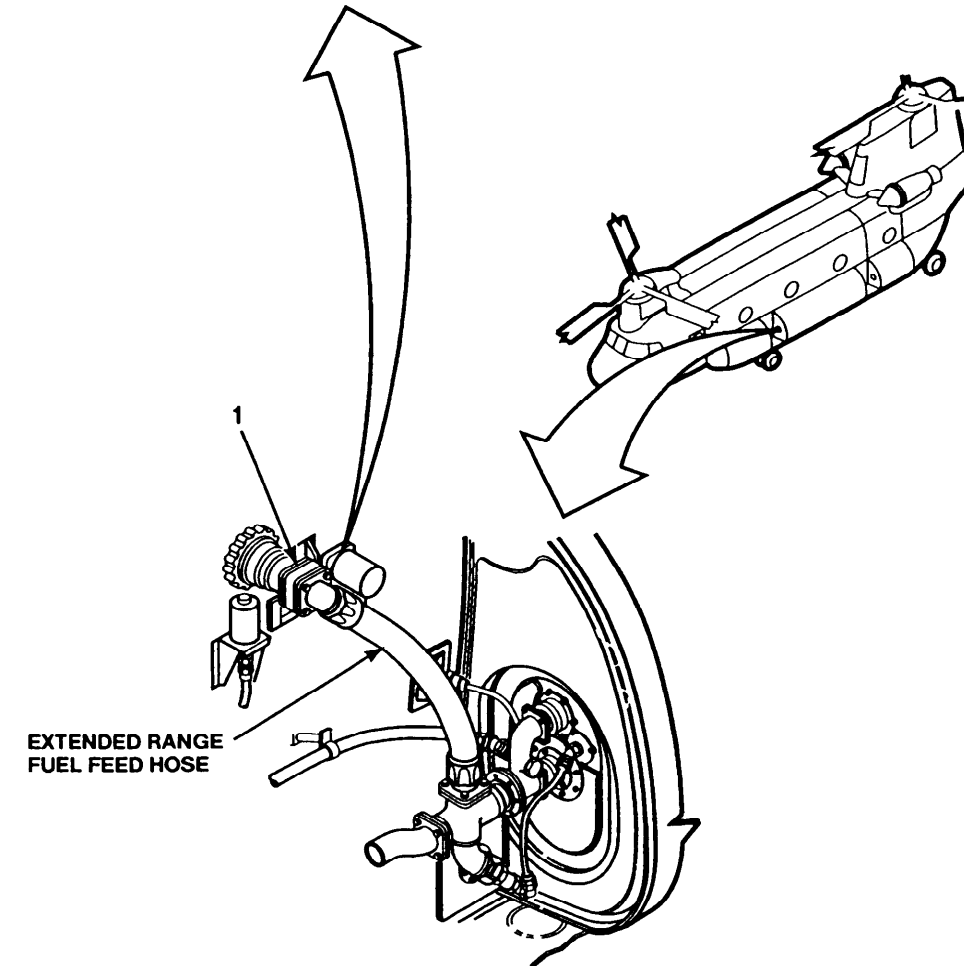
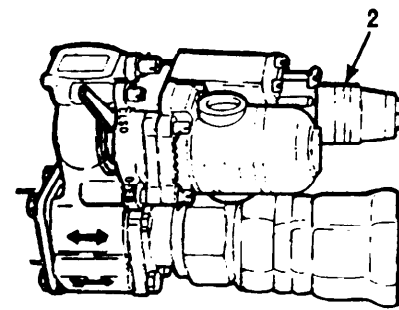

A73209

END OF TASK

INITIAL SETUP

TM 1-1560-312-10

Applicable Configurations:

With 82

Tools:

None

Materials:

None

Personnel Required:

Medium Helicopter Repairer

References:

TM 55-1520-240-23

Equipment Condition:

TM 55-1520-240-23:

Electrical Power Off

Battery Connected

Hydraulic Power Off

TM 1-1560-312-10:

ERFS II Fuel Control Panel Connected

Visual Check of ERFS II Airframe Components

Performed (Task 10-4.3)

TASK	RESULT
1. Check that FUEL REFUEL circuit breaker (1) is closed.	If circuit breaker (1) is open, close it. If it opens again, go to task 10-4.5.
2. Set REFUEL STATION switch (2) to ON.	
3. Set ERFS II REFUEL VALVE switch (3) to OPEN.	IN-TRANSIT light (4) comes on during valve (5) operation and goes out when valve is open. Check that ERFS II refuel valve handle (6) is in OPEN position. If light (4) does not come on and handle is not at OPEN, go to task 10-4.6. If light comes on and stays on but handle is not at OPEN, go to task 10-4.7. If light does not come on but handle is at OPEN, go to task 10-4.8. If light comes on and stays on but handle is at OPEN, replace ERFS II refuel valve.
4. Set ERFS II REFUEL VALVE switch (3) to CLOSE.	IN-TRANSIT light (4) comes on during valve (5) operation and goes out when valve is closed. Check that ERFS II refuel valve handle (6) is in CLSD position. If light (4) does not come on and handle is not at CLSD, go to task 10-4.9. If light comes on and stays on but handle is at CLSD, replace ERFS II refuel valve.

FOLLOW-ON MAINTENANCE:

TM 55-1520-240-23:

Battery disconnected.

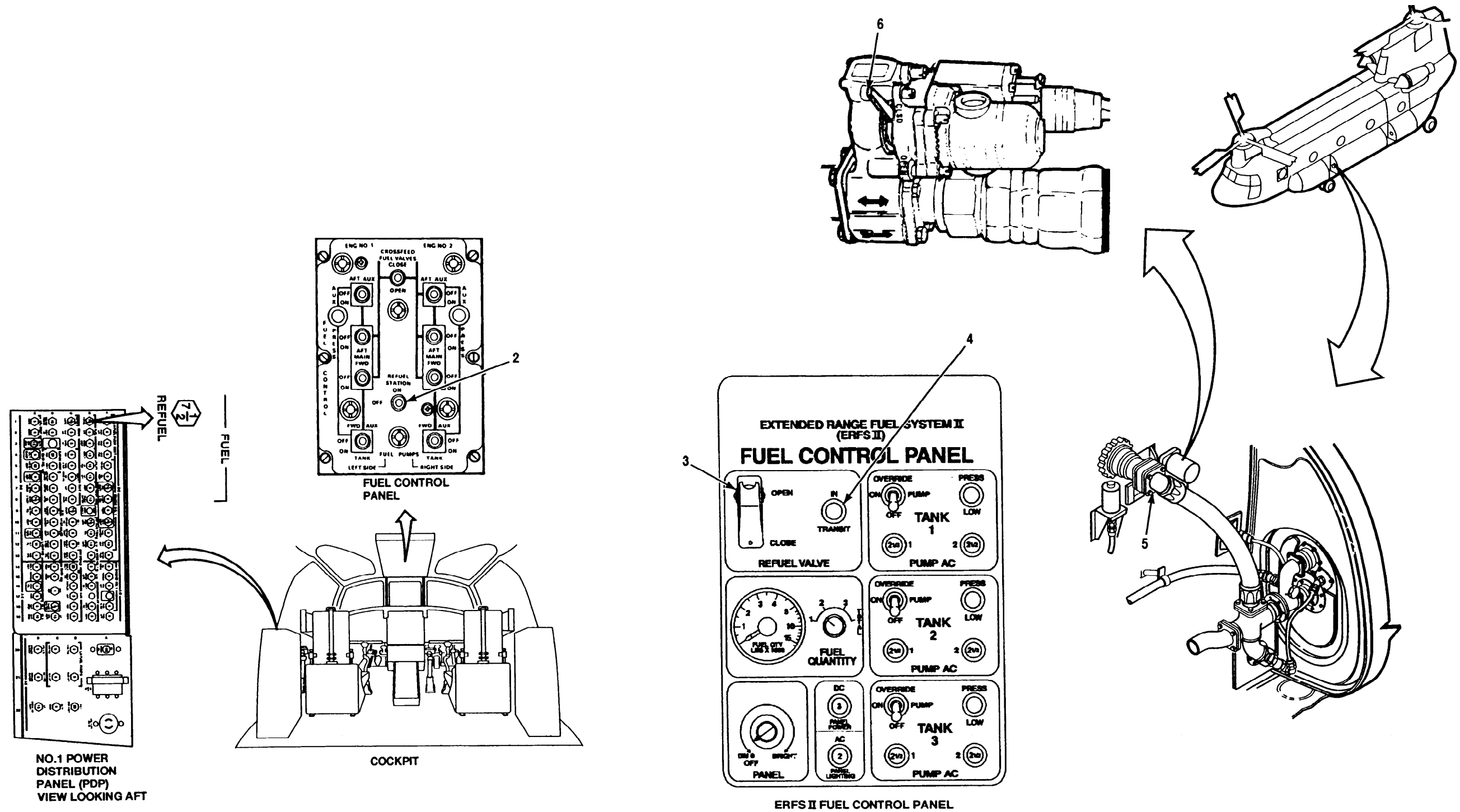

A73210

FAULT ISOLATION PROCEDURE

INITIAL SETUP

Applicable Configurations:

With 82

Tools:

- Electrical Repairer's Tool Kit,
- NSN 5180-00-323-4915
- Multimeter

Materials:

None

Personnel Required:

Aircraft Electrician

References:

- TM 55-1520-240-23
- TM 1-1560-312-23 & P

Equipment Condition:

- TM 55-1520-240-23:
- Battery Disconnected
- Electrical Power On
- Hydraulic Power Off

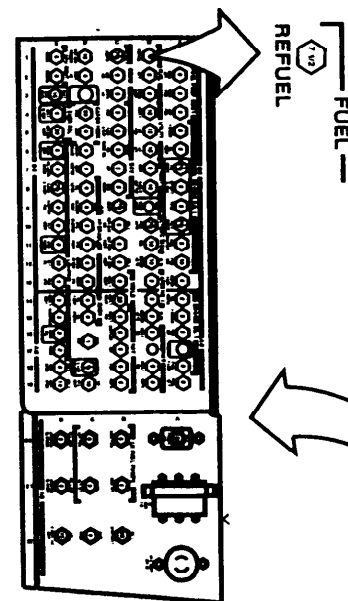

NO.1 POWER DISTRIBUTION PANEL (PDP) VIEW LOOKING AFT

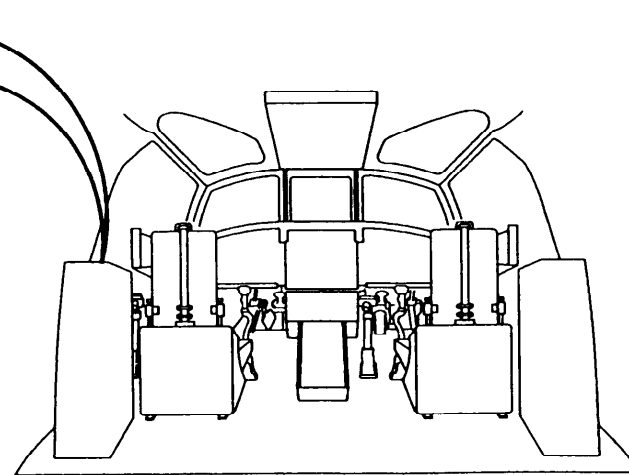

COCKPIT

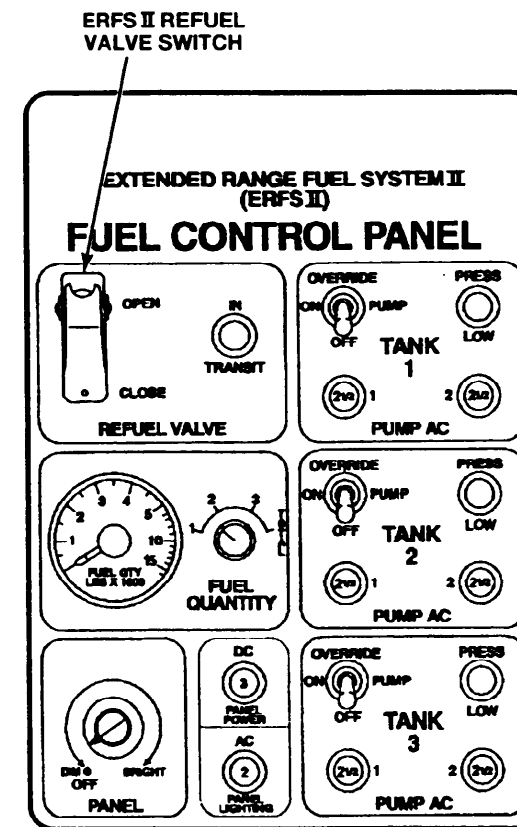

ERFS FUEL CONTROL PANEL

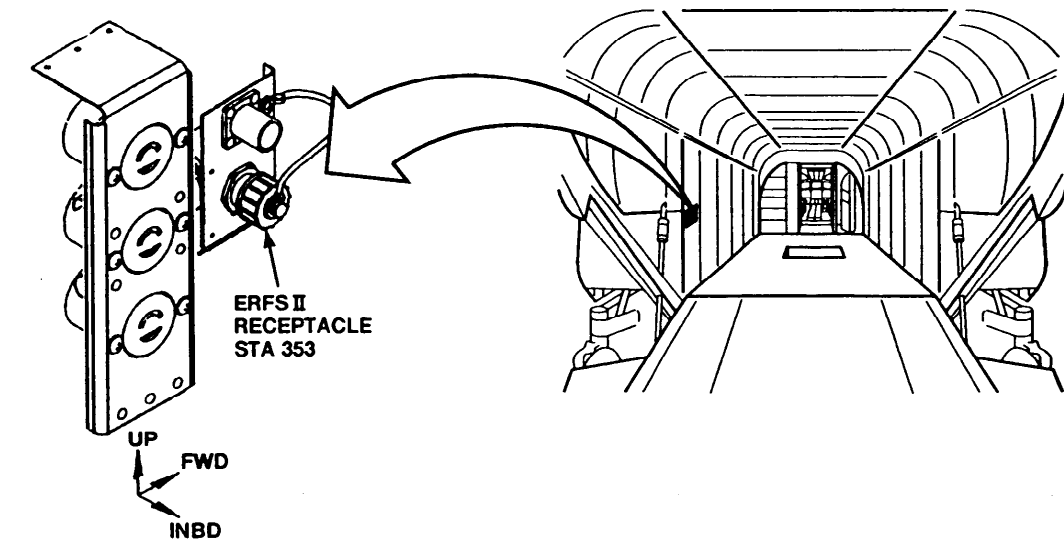
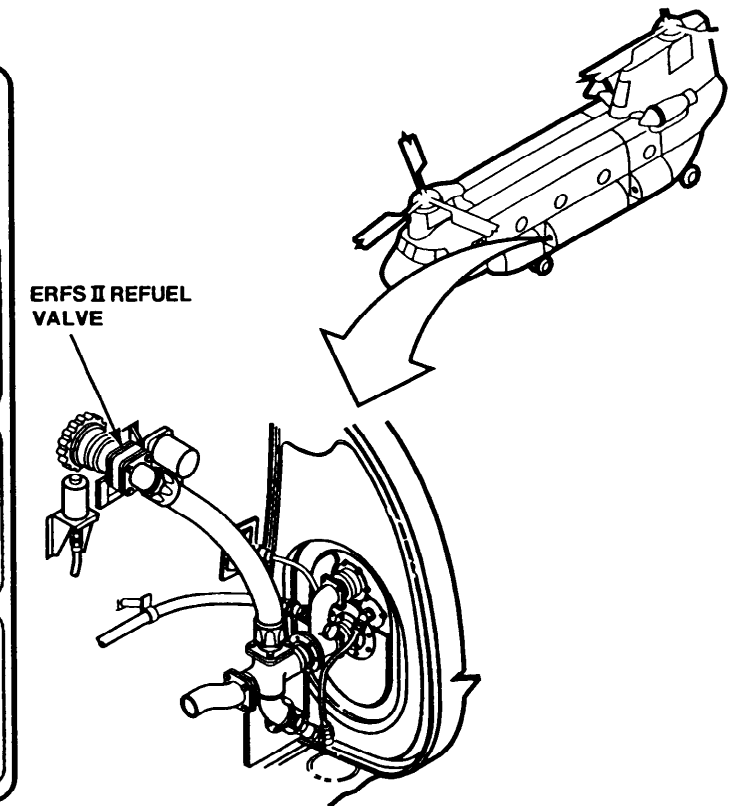

A73211

GO TO NEXT PAGE

10-4.5 FUEL REFUEL CIRCUIT BREAKER WILL NOT STAY CLOSED WHEN ERFS II FUEL CONTROL PANEL IS CONNECTED (Continued)

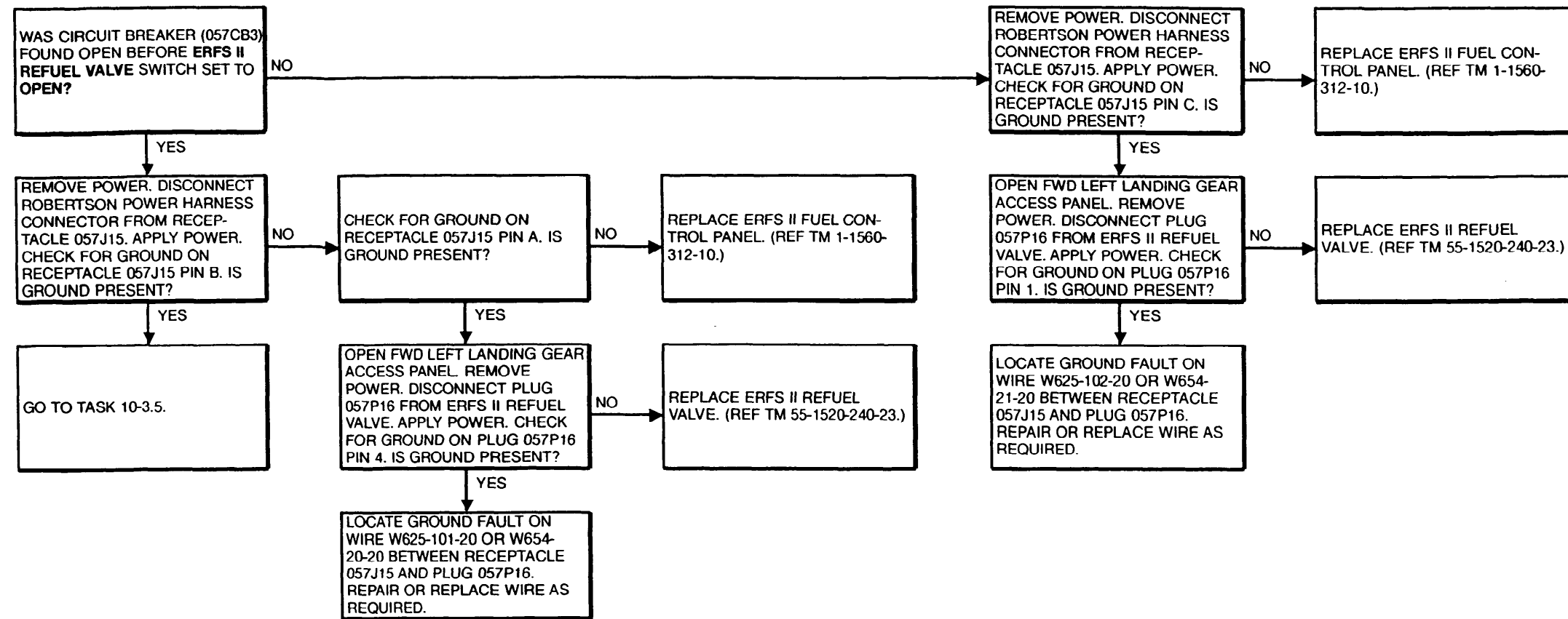

FAULT ISOLATION PROCEDURE

INITIAL SETUP

Applicable Configurations:

With **82**

Tools:

Electrical Repairer's Tool Kit,
NSN 5180-00-323-4915

Materials:

None

Personnel Required:

Aircraft Electrician

References:

TM 55-1520-240-23
TM 1-1560-312-23 & P

Equipment Condition:

TM 55-1520-240-23:
Battery Connected
Electrical Power On
Hydraulic Power Off

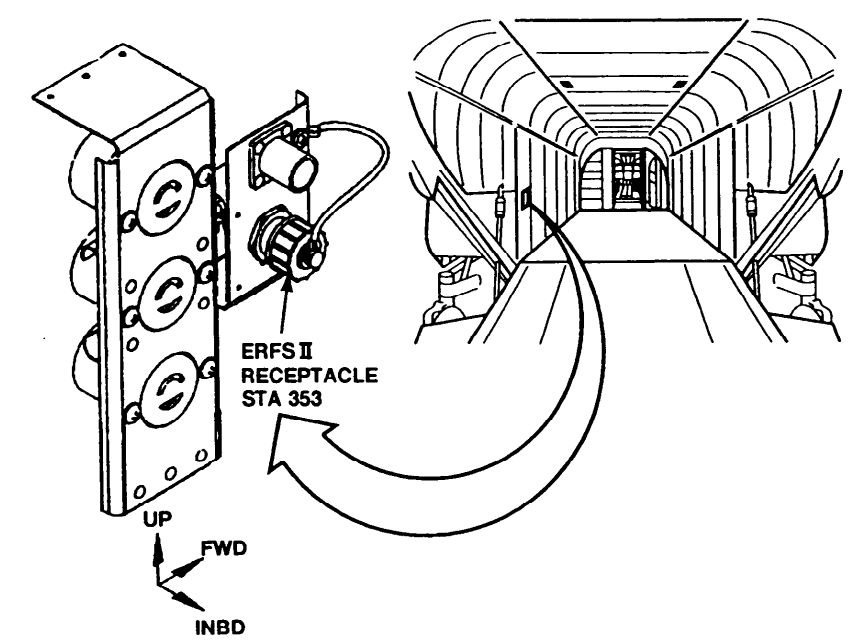
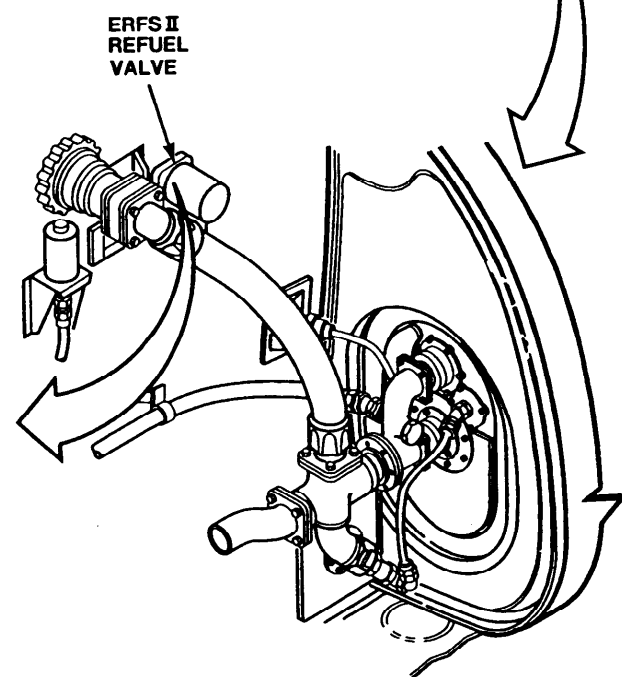
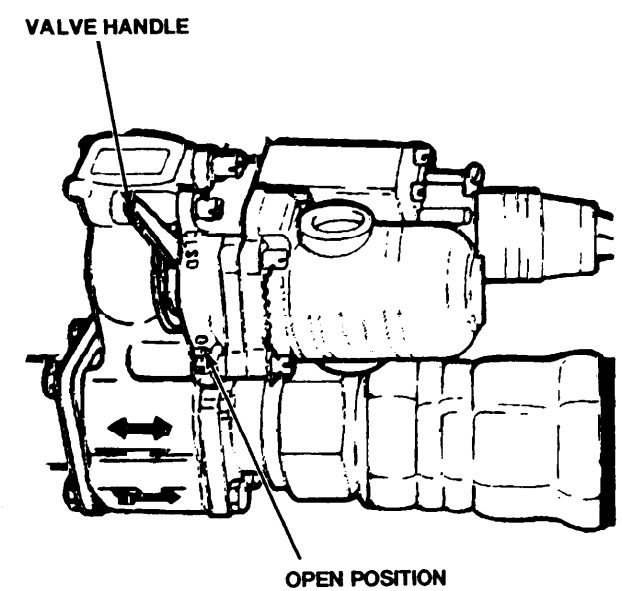
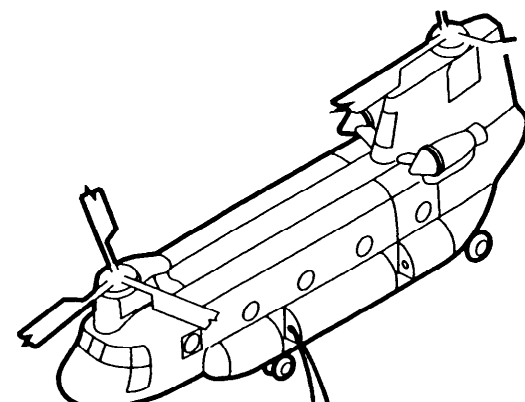
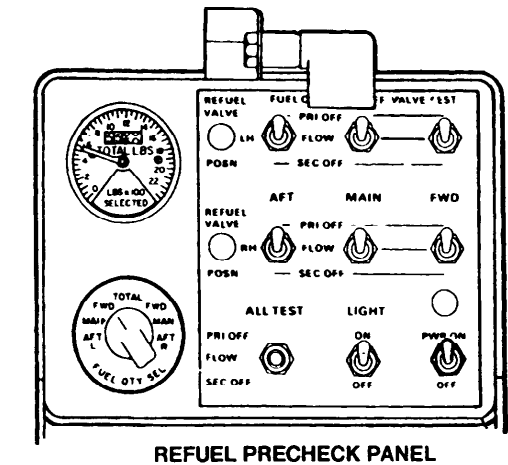
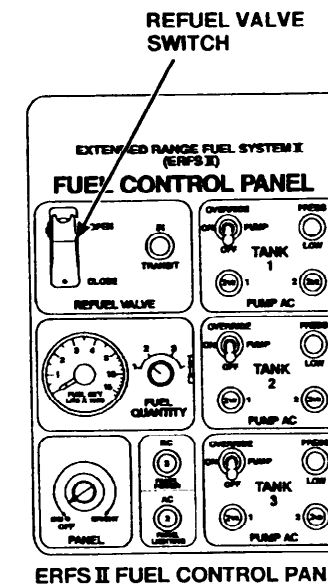
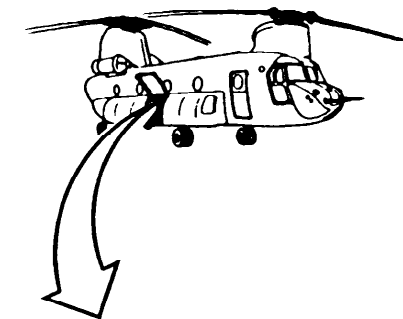

A73215

GO TO NEXT PAGE

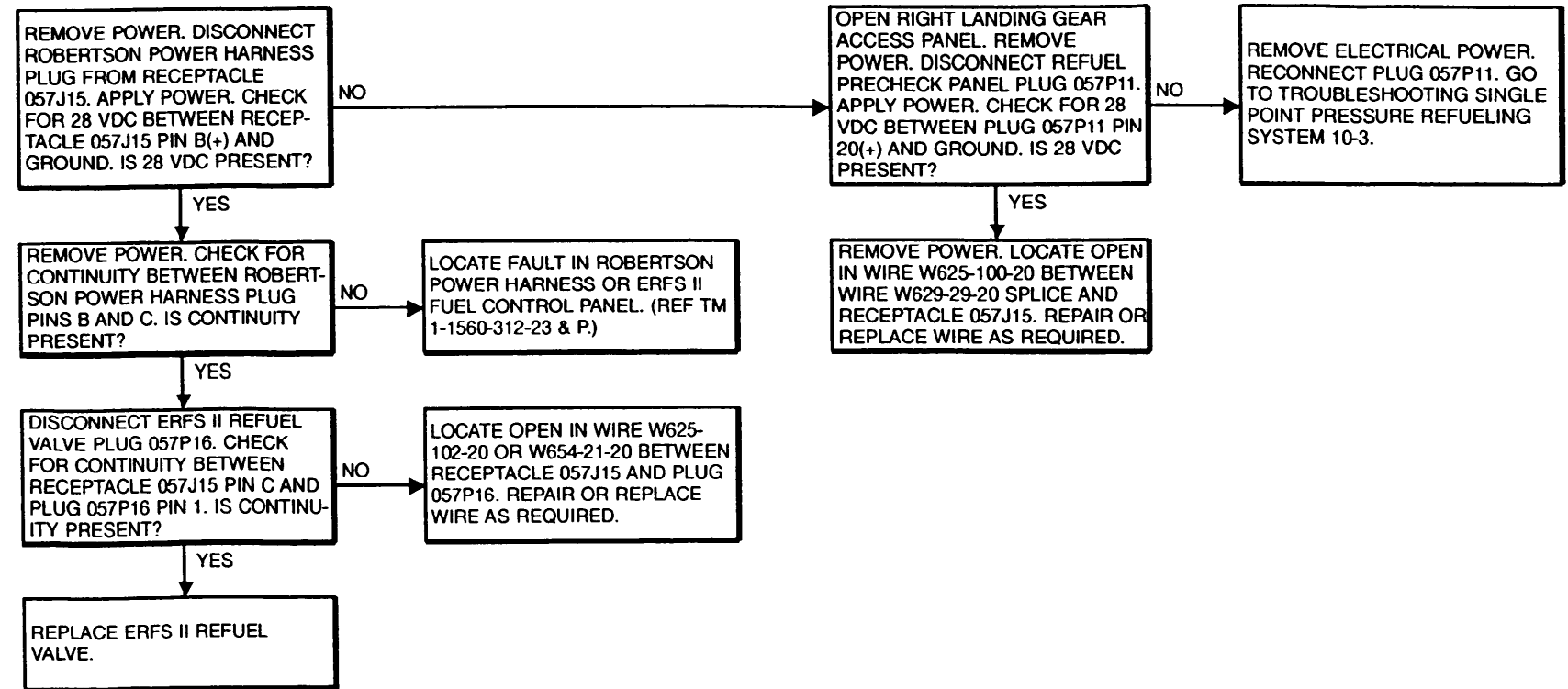

FAULT ISOLATION PROCEDURE

INITIAL SETUP

Applicable Configurations:

With **82**

Tools:

Electrical Repairer's Tool Kit,
NSN 5180-00-323-4915

Materials:

None

Personnel Required:

Aircraft Electrician

References:

TM 55-1520-240-23

Equipment Condition:

TM 55-1520-240-23:

Battery Connected

Power Off

Hydraulic Power Off

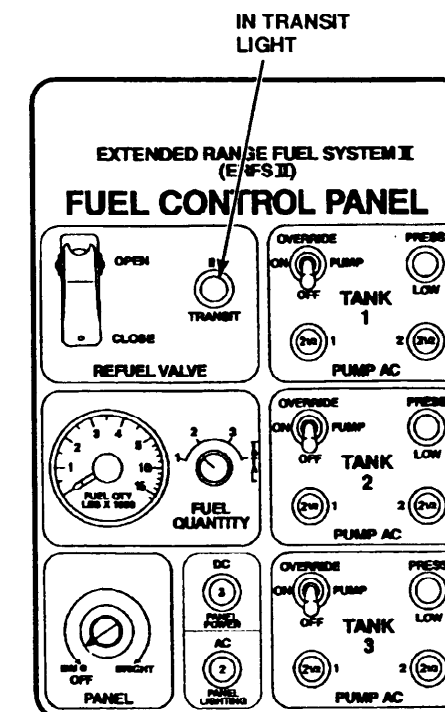
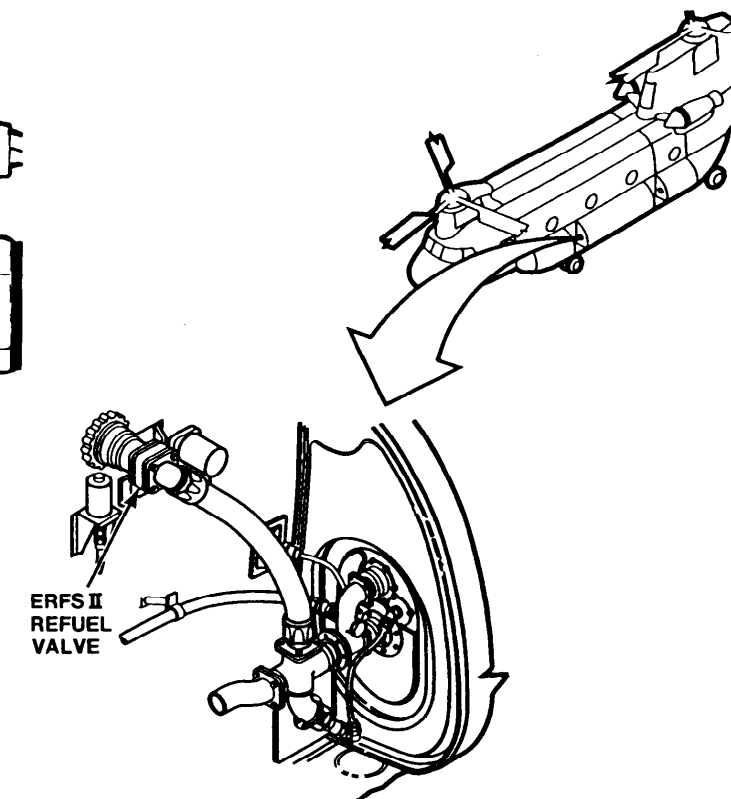
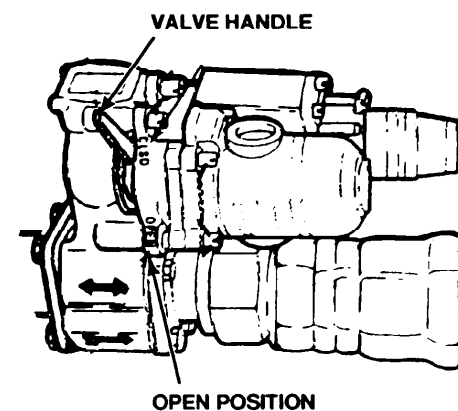
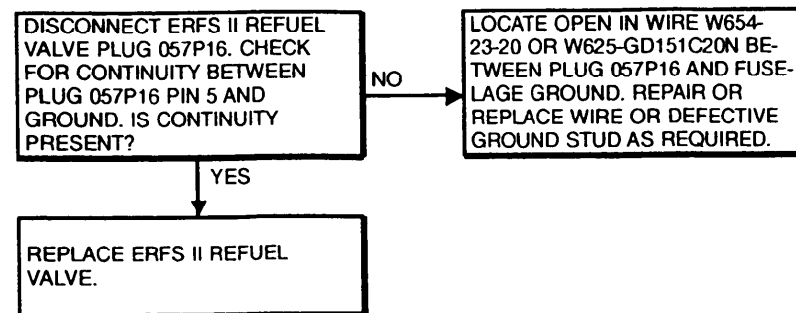

FAULT ISOLATION PROCEDURE

INITIAL SETUP

Applicable Configurations:

With 82

Tools:

Electrical Repairer's Tool Kit,
NSN 5180-00-323-4915

Materials:

None

Personnel Required:

Aircraft Electrician

References:

TM 55-1520-240-23
TM 1-1560-312-23 & P

Equipment Condition:

TM 55-1520-240-23:
Battery Connected
Electrical Power On
Hydraulic Power Off

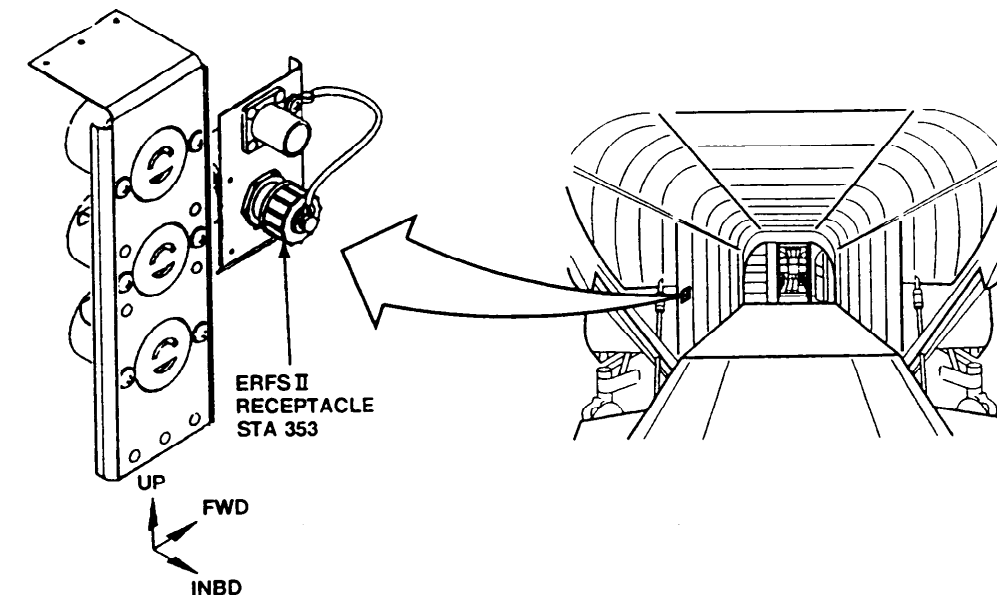
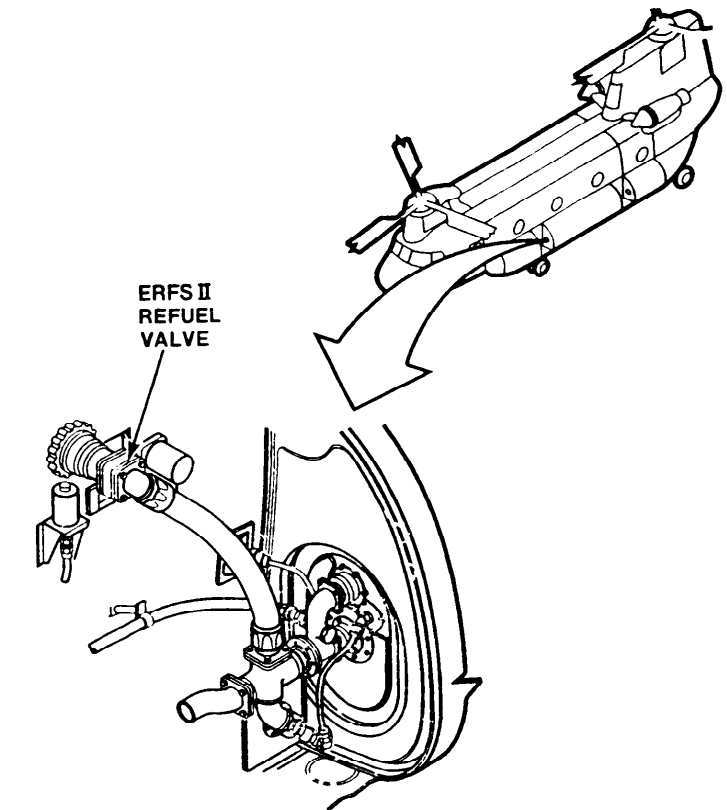
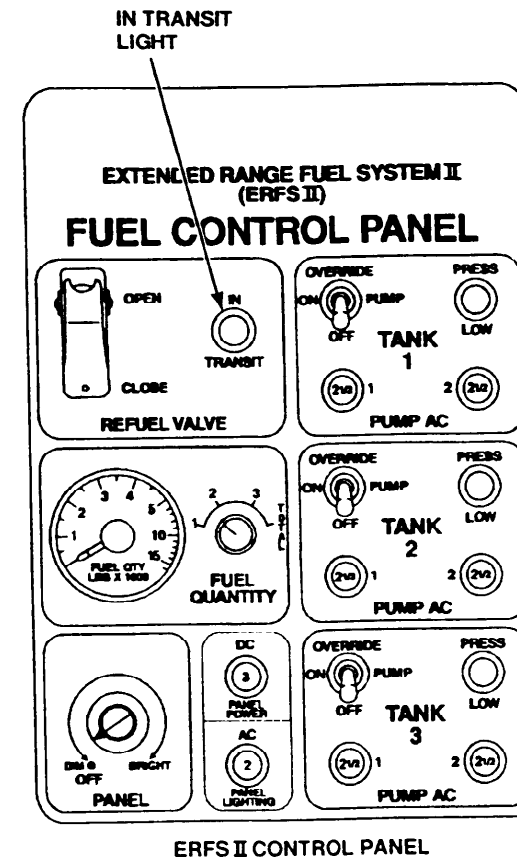

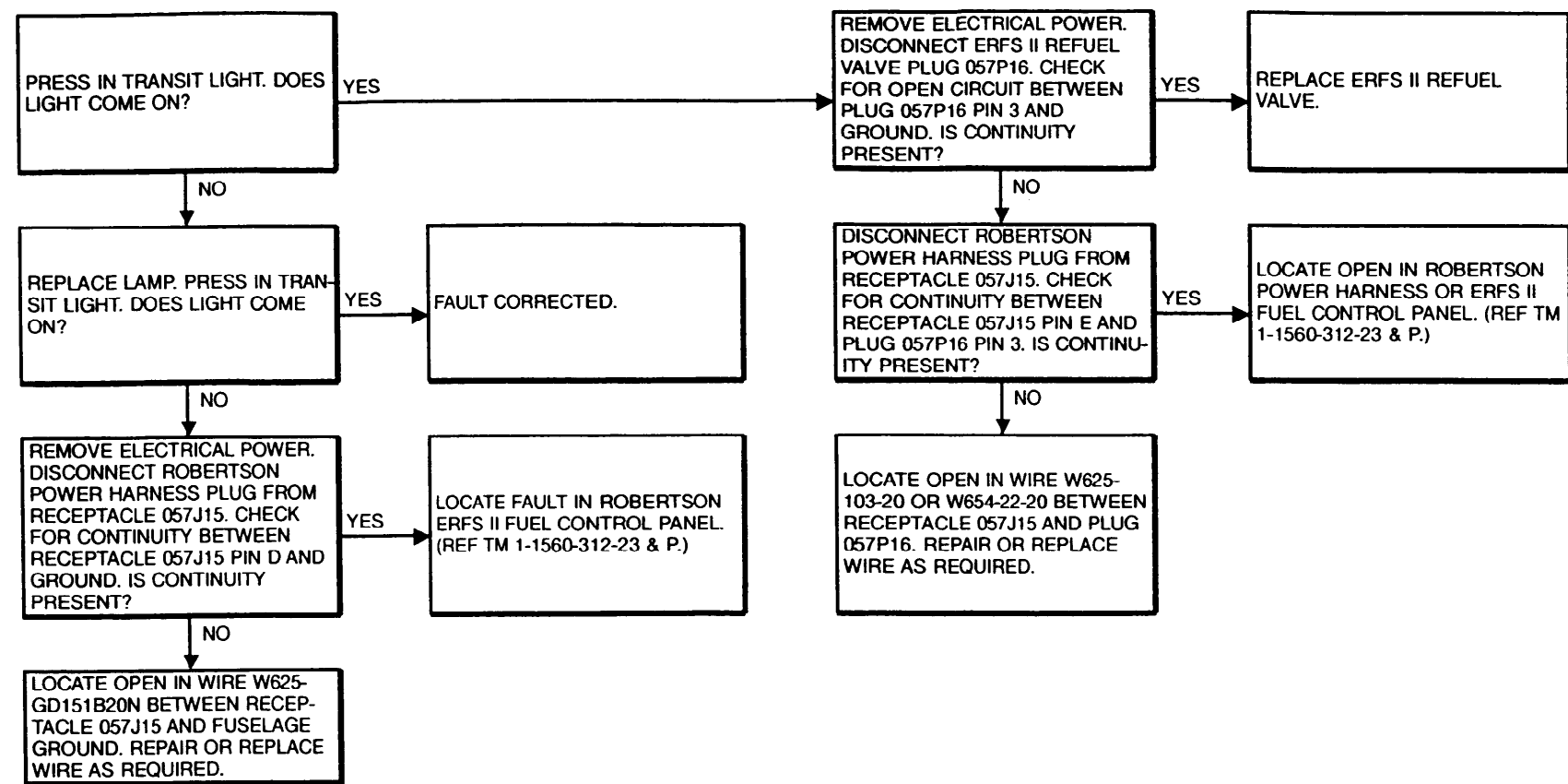

FAULT ISOLATION PROCEDURE

INITIAL SETUP

Applicable Configurations:

With **82**

Tools:

Electrical Repairer's Tool Kit,
NSN 5180-00-3234915

Materials:

None

Personnel Required:

Aircraft Electrician

References:

TM 55-1520-240-23
TM 1-1560-312-23 & P

Equipment Condition:

TM 55-1520-240-23:
Battery Connected
Electrical Power Off
Hydraulic Power Off

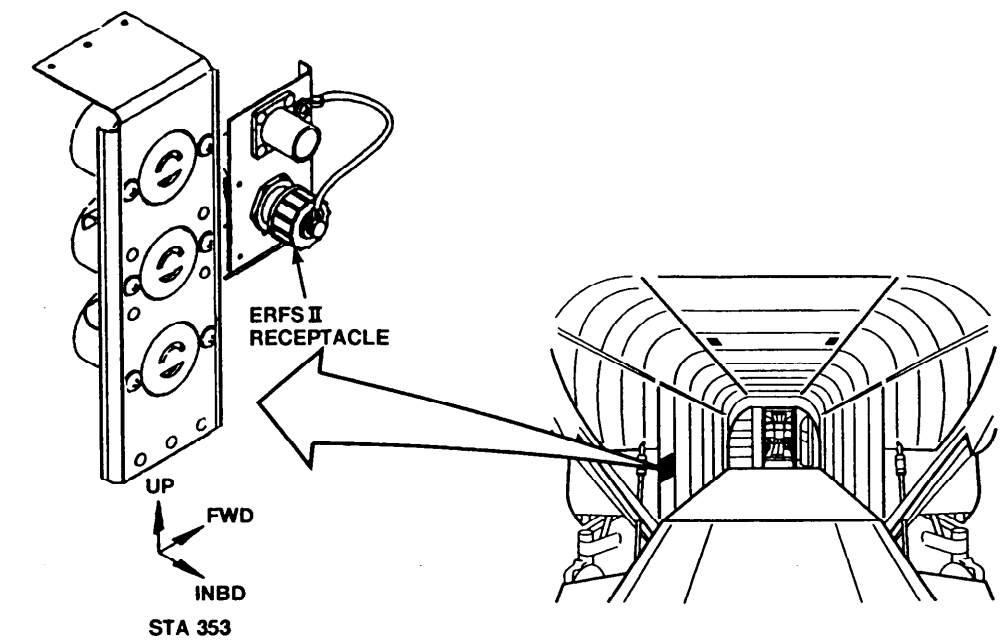
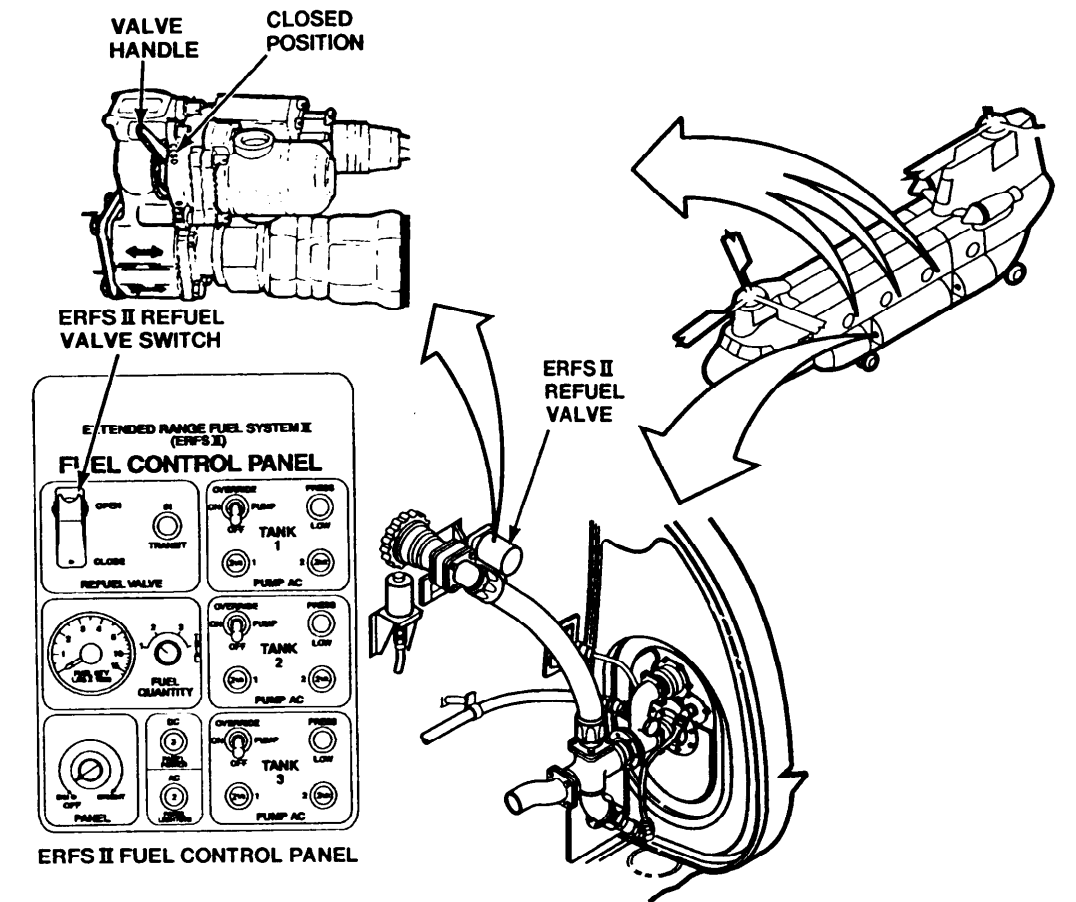
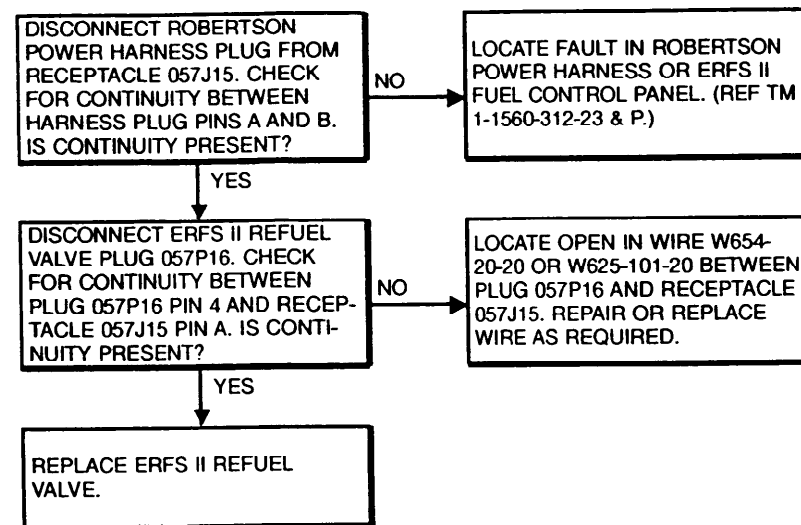

END OF TASK

CHAPTER 11
FLIGHT CONTROLS SYSTEMS
TROUBLESHOOTING

CHAPTER 11
FLIGHT SYSTEM TROUBLESHOOTING
CHAPTER OVERVIEW

Chapter 11 contains procedures for Flight System troubleshooting. Each system and failure symptom is listed below. Included in this chapter are locations and views of all electrical connectors, receptacles, relays, and ground connections for the Flight System.

Refer to TM 55-1520-240-23 for required maintenance procedures.

SYMPTOM	PARA	SYMPTOM	PARA
FLIGHT CONTROL SYSTEM	11-1	AFCS CONTROL PANEL	11-4
ARTIFICIAL FEEL - MAGNETIC BRAKES	11-2	AFCS COMPUTER	11-5
ADVANCED FLIGHT CONTROLS SYSTEM (AFCS)	11-3	COCKPIT CONTROL DRIVE ACTUATOR (CCDA)	11-6

FAILURE SYMPTOM LIST

ARTIFICIAL FEEL - MAGNETIC BRAKES

SYMPTOM	TASK	SYMPTOM	TASK	SYMPTOM	TASK
CONT CENTER CIRCUIT BREAKER DOES NOT STAY CLOSED	11-2.3	CONTROL STICK WILL NOT REMAIN AT SELECTED POSITION AFTER COPILOT'S CENTERING DEVICE RELEASE SWITCH RELEASED	11-2.3	PEDALS DO NOT REMAIN AT SELECTED POSITION	11-2.3
CONTROL STICK AND PEDALS WILL NOT STAY CENTERED AFTER PILOT'S CENTERING DEVICE RELEASE SWITCH RELEASED	11-2.3	COPILOT'S THRUST CONTROL DOES NOT EASILY MOVE OR DOES NOT REMAIN AT SELECTED POSITION	11-2.3	PILOT'S THRUST CONTROL DOES NOT EASILY MOVE OR DOES NOT REMAIN AT SELECTED POSITION	11-2.3
CONTROL STICK DOES NOT REMAIN AT SELECTED POSITION	11-2.3			THRUST BRAKE CIRCUIT BREAKER DOES NOT STAY CLOSED	11-2.3

GO TO NEXT PAGE

Change 3 11-2.1

ADVANCED FLIGHT CONTROLS SYSTEM

SYMPTOM	TASK	SYMPTOM	TASK	SYMPTOM	TASK
AFCS BITE OPERATES WITH ENGINE CONDITION LEVER IN FLIGHT POSITION	11-3.3	BOTH LCT INDICATORS NOT IN GROUND POSITION	11-3.3	NO. 1 AFCS COMPUTER BITE SWITCH DOES NOT LIGHT AND COUNTER DOES NOT STOP WHEN BITE SWITCH PRESSED AND RELEASED	11-3.3
AFCS COMPUTER BITE INDICATES 48	11-3.3	CLTV DRIVER ACTR AC CIRCUIT BREAKER WILL NOT STAY CLOSED	11-3.3	NO. 1 AFCS HEADING SELECT MODE RESPONSE WEAK OR INOPERATIVE	11-3.3
AFCS COMPUTER BITE INDICATES 6, 9, OR 18	11-3.3	CLTV DRIVER ACTR CIRCUIT BREAKER WILL NOT STAY CLOSED	11-3.3	NO. 1 AFCS OFF (WITHOUT 74) OR AFCS 1 (WITH 74) CAPSULE DOES NOT GO OUT WHEN SYSTEM SELECTED	11-3.3
AFCS COMPUTER BITE INDICATES 70-74	11-3.3	CYCLIC TRIM AFT ACTR CIRCUIT BREAKER WILL NOT STAY CLOSED	11-3.3	NO. 1 AFCS OFF (WITHOUT 74) OR AFCS 1 (WITH 74) CAPSULE IS OUT WITH SYSTEM SELECTED OFF	11-3.3
AFCS COMPUTER BITE INDICATES 95	11-3.3	CYCLIC TRIM FWD ACTR CIRCUIT BREAKER WILL NOT STAY CLOSED	11-3.3	NO. 1 AFCS PITCH ATTITUDE/AIR SPEED HOLD WEAK OR INOPERATIVE	11-3.3
AFCS HEADING HOLD WEAK OR INOPERATIVE	11-3.3	CYCLIC TRIM MNL CIRCUIT BREAKER WILL NOT STAY CLOSED	11-3.3	NO. 1 AFCS YAW STABILITY ERRATIC/OSCILLATORY	11-3.3
AFCS LONGITUDINAL CONTROL POSITION OUT OF TRIM	11-3.3	FORWARD LCT INDICATOR DOES NOT INDICATE EXTEND OR RETRACT DURING MANUAL CONTROL	11-3.3	NO. 1 PITCH ILCA HAS ENGAGE TRANSIENT	11-3.3
AFT LCT INDICATOR DOES NOT SHOW EXTENSION OR RETRACTION IN MANUAL CONTROL	11-3.3	FORWARD LCT INDICATOR NOT IN GND POSITION	11-3.3	NO. 1 ROLL ILCA DOES NOT EXTEND OR RETRACT WITH LATERAL STICK MOTION	11-3.3
AFT LCT INDICATOR NOT IN GND POSITION	11-3.3	HDG SWITCH ENGAGE CAPTION DOES NOT LIGHT	11-3.3	NO. 1 ROLL ILCA DOES NOT MOVE WHEN PILOT'S PITCH AND ROLL TRIM SWITCH MOVED RIGHT OR LEFT	11-3.3
AFCS LATERAL STICK ONLY TURNS NOT COORDINATED	11-3.3	HEADING SELECT MODE RESPONSE WEAK OR INOPERATIVE (BOTH SYSTEMS)	11-3.3	NO. 1 ROLL ILCA HAS ENGAGE TRANSIENT	11-3.3
AFCS NO. 1 DC CIRCUIT BREAKER WILL NOT STAY CLOSED	11-3.3	NO. 1 AFCS AC CIRCUIT BREAKER WILL NOT STAY CLOSED	11-3.3		
AFCS NO. 2 DC CIRCUIT BREAKER WILL NOT STAY CLOSED	11-3.3	NO. 1 AFCS COMPUTER BITE INDICATES 85 OR 86	11-3.3		
AFCS PITCH STABILIZATION ERRATIC OR OSCILLATORY	11-3.3	NO. 1 AFCS COMPUTER BITE INDICATES 87	11-3.3		
AFCS ROLL STABILIZATION ERRATIC/OSCILLATORY OR ROLL ATTITUDE HOLD WEAK OR INOPERATIVE	11-3.3	NO. 1 AFCS COMPUTER BITE INDICATES 89	11-3.3		
BAROMETRIC ALTITUDE HOLD INOPERATIVE OR RESPONSE ERRATIC (RADAR ATTITUDE HOLD OKAY)	11-3.3				
BAROMETRIC AND RADAR ALTITUDE HOLD INOPERATIVE OR RESPONSE ERRATIC	11-3.3				

ADVANCED FLIGHT CONTROLS SYSTEM (Continued)

SYMPTOM	TASK	SYMPTOM	TASK	SYMPTOM	TASK
NO. 1 YAW ILCA DOES NOT EXTEND OR RETRACT WHEN PEDALS ARE MOVED	11-3.3	NO. 2 AFCS OFF (WITHOUT 74) OR AFCS 2 (WITH 74) CAPSULE DOES NOT GO OUT WHEN SYSTEM SELECTED	11-3.3	NO. 2 ROLL ILCA DOES NOT MOVE WHEN PILOT'S OR COPILOT'S PITCH AND ROLL TRIM SWITCH MOVED RIGHT OR LEFT	11-3.3
NO. 1 YAW ILCA HAS ENGAGE TRANSIENT	11-3.3	NO. 2 AFCS OFF (WITHOUT 74) OR AFCS 2 (WITH 74) CAPSULE IS OUT WITH SYSTEM SELECTED OFF	11-3.3	NO. 2 ROLL ILCA HAS ENGAGE TRANSIENT	11-3.3
NO. 2 AFCS AC CIRCUIT BREAKER WILL NOT STAY CLOSED	11-3.3	NO. 2 AFCS PITCH ATTITUDE/AIR SPEED HOLD WEAK OR INOPERATIVE	11-3.3	NO. 2 YAW ILCA DOES NOT EXTEND OR RETRACT WHEN PEDALS ARE MOVED	11-3.3
NO. 2 AFCS COMPUTER BITE INDICATES 85 OR 86	11-3.3	NO. 2 AFCS YAW STABILITY ERRATIC/OSCILLATORY	11-3.3	NO. 2 YAW ILCA HAS ENGAGE TRANSIENT	11-3.3
NO. 2 AFCS COMPUTER BITE INDICATES 89	11-3.3	NO. 2 PITCH ILCA HAS ENGAGE TRANSIENT	11-3.3	PITCH AND ROLL CONTROL STICK DOES NOT MOVE FORWARD OR AFT WHEN PILOT'S OR COPILOT'S PITCH AND ROLL TRIM SWITCH IS MOVED FORWARD AND AFT	11-3.3
NO. 2 AFCS COMPUTER BITE SWITCH DOES NOT LIGHT AND COUNTER DOES NOT STEP WHEN BITE SWITCH IS PRESSED AND RELEASED	11-3.3	NO. 2 ROLL ILCA DOES NOT EXTEND OR RETRACT WITH LATERAL STICK MOTION	11-3.3	RADAR ALTITUDE HOLD INOPERATIVE OR RESPONSE ERRATIC (BAROMETRIC ALTITUDE HOLD OKAY)	11-3.3
NO. 2 AFCS HEADING SELECT MOVE RESPONSE WEAK OR INOPERATIVE	11-3.3			RADAR OR BARO ALT ENGAGED CAPTIONS DO NOT COME ON WHEN PRESSED	11-3.3

AFCS CONTROL PANEL

SYMPTOM	TASK
AFCS CONTROL PANEL FAILS BAROMETRIC ALTITUDE TESTS	11-4.2
AFCS CONTROL PANEL FAILS CYCLIC TRIM - AUTOMATIC TEST	11-4.2
AFCS CONTROL PANEL FAILS CYCLIC TRIM MANUAL TEST	11-4.2

SYMPTOM	TASK
AFCS CONTROL PANEL FAILS DIODE TEST	11-4.2
AFCS CONTROL PANEL FAILS HEADING TEST	11-4.2
AFCS CONTROL PANEL FAILS PANEL ILLUMINATION TEST	11-4.2

SYMPTOM	TASK
AFCS CONTROL PANEL FAILS RADAR ALTITUDE TESTS	11-4.2
AFCS CONTROL PANEL FAILS SYSTEMS SELECT TEST	11-4.2

CHAPTER 11
 FLIGHT CONTROLS SYSTEMS TROUBLESHOOTING

CHAPTER OVERVIEW (Continued)

FAILURE SYMPTOM LIST (Continued)

AFCS COMPUTER

SYMPTOM	TASK	SYMPTOM	TASK	SYMPTOM	TASK
AFCS COMPUTER FAILS TEST 1 (CONTINUITY TEST)	11-5.2	AFCS COMPUTER FAILS TEST 5 (ROLL AXIS TEST)	11-5.2	AFCS COMPUTER FAILS TEST 10 (YAW RATE TEST)	11-5.2
AFCS COMPUTER FAILS TEST 2 (POWER SUPPLY TEST)	11-5.2	AFCS COMPUTER FAILS TEST 6 (YAW AXIS TEST)	11-5.2	AFCS COMPUTER FAILS TEST 11 (NORMAL ACCELERATION TEST)	11-5.2
AFCS COMPUTER FAILS TEST 3 (LOGIC TEST)	11-5.2	AFCS COMPUTER FAILS TEST 7 (DASH TEST)	11-5.2	AFCS COMPUTER FAILS TEST 12 (PRESSURE TRANSDUCERS TEST)	11-5.2
AFCS COMPUTER FAILS TEST 4 (PITCH AXIS TEST)	11-5.2	AFCS COMPUTER FAILS TEST 8 (LONGITUDINAL CYCLIC TRIM (LCT) TEST)	11-5.2	AFCS COMPUTER FAILS TEST 13 (BITE TEST)	11-5.2
		AFCS COMPUTER FAILS TEST 9 (COLLECTIVE CONTROL DRIVER ACTUATOR (CCDA) TEST)	11-5.2		

**FAILURE SYMPTOM LIST (Continued)
COCKPIT CONTROL DRIVE ACTUATOR (CCDA)**

SYMPTOM	TASK
PITCH COCKPIT CONTROL DRIVE ACTUATOR FAILS BRAKE FUNCTION TEST	11-6.2
PITCH COCKPIT CONTROL DRIVE ACTUATOR FAILS CIRCUIT RESISTANCE TEST	11-6.2

SYMPTOM	TASK
PITCH COCKPIT CONTROL DRIVE ACTUATOR FAILS TRIM MOTOR TEST	11-6.2
THRUST COCKPIT CONTROL DRIVE ACTUATOR FAILS BRAKE FUNCTION TEST	11-6.2

SYMPTOM	TASK
THRUST COCKPIT CONTROL DRIVE ACTUATOR FAILS CIRCUIT RESISTANCE TEST	11-6.2
THRUST COCKPIT CONTROL DRIVE ACTUATOR FAILS NULL VOLTAGE AND PHASING TEST	11-6.2

FLIGHT SYSTEM ELECTRICAL COMPONENT LOCATION AND CONFIGURATION LIST

REF DESIG	PART NUMBER	TYPE	MATE WITH/LOCATION	STATION LOCATION			REF DESIG	PART NUMBER	TYPE	MATE WITH/LOCATION	STATION LOCATION		
				FS	WL	BL					FS	WL	BL
009		150	CONSOLE, FWD CTR INSTR PNL				031P15	M83723-95A1415N	34	CONTROLS CLOSET, ROLL LWR CONTACT			
040		150	CONSOLE, FWD CTR INSTR PNL				031P16	M83723-95A1415N	34	CONTROLS CLOSET, ROLL LWR CONTACT			
131		151	RH AFT CABIN	485	-5	50R	031P17	M83723-95A1415N	34	CONTROLS CLOSET, YAW LWR CONTACT			
GD217		151	CONTROLS CLOSET	110	15	18L	031P18	M83723-95A1415N	34	CONTROLS CLOSET, YAW LWR CONTACT			
GD218		151	CONTROLS CLOSET	110	15	18L	031 P19	M83723-95A1212N	31	CONTROLS CLOSET, DUAL DIFF A/S HOLD ACT			
GD220		151	CONTROLS CLOSET	110	15	18L	031 P20	M83723-95A1212N	31	CONTROLS CLOSET, DUAL DIFF A/S HOLD ACT			
GD223		151	CONTROLS CLOSET	110	15	18L	031P22	MS3476W14-19S	21	CONT CLOSET, CLTV CONT DR ACTR	95	-2	15L
GD224		151	CONTROLS CLOSET	117	30	18L	031P26	M83723-95A0803N	29	CONT CLOSET, ROLL MAG BRAKE	120	-10	15L
GD228		151	FWD XMSN AREA	105	45	20L	031P27	MS3476W14-19S	21	CONT CLOSET, PITCH CCDA	120	0	15L
GD229		151	FWD XMSN AREA	105	45	20L	031 P28	M83723-95A0803N	29	CONT CLOSET, YAW MAG BRAKE	95	8	15L
GD230		151	ELECTRONIC COMP	110	15	50L	031 P32	MS3147E7-50S	9	CONSOLE, CTR INSTR PNL, FWD CYCLIC TRIM IND			
GD231		151	ELECTRONIC COMP	110	15	50L	031 P33	MS3147E7-50S	9	CONSOLE, CTR INSTR PNL, AFT CYCLIC TRIM IND			
GD250		151	ELECTRONIC COMP	115	10	18L	031P34	M83723-75A1212N	31	ELECTRONICS COMP, ROLL ERECT CUTOUT RLY			
GD251		151	RH POD	256	-10	52R	031P35	M83723-75A1212N	31	ELECTRONICS COMP, ROLL ERECT CUTOUT RLY			
GD252		151	ELECTRONIC COMP	115	10	18L	031P36	MS3476W14-19S	21	CONSOLE, AFCS CONT PNL			
GD253		151	ELECTRONIC COMP	110	15	50L	062P3	MS3476W16-26S	24	ELECTRONICS COMP, 3RD SHLF, CPLT GYRO			
GD254		151	RH POD	258	-10	52R	062P4	MS3476W16-26S	24	ELECTRONICS COMP, 2ND SHLF, PLT GYRO			
GD255		151	ELECTRONIC COMP	110	15	18L	102P5	MS3476W14-19SW	21	OVHD PNL, ENG COND CONT PNL			
GD258		151	LH AFT, CABIN	502	-20	50L	148J1	MS3474W10-6S	15	RH AFT RAMP AREA	485	-30	52R
TB 18			COCKPIT, UNDERFLOOR, CPLT				148P1	MS3476W10-6P	15	RH AFT LDG GEAR COMP	485	-30	52R
TB 52			ELECTRONIC COMP	95	14	246	148J2	MS3474W10-6S	15	LH AFT RAMP AREA	485	-30	52L
TB 53			ELECTRONIC COMP	95	14	30L	148P2	MS3476W10-6P	15	LH AFT LDG GEAR COMP	485	-30	52L
148K1		103	LH AFT CABIN	482	20	50L	232P1	MS3476W20-41S	26	CONSOLE, CTR INSTR PNL, MSTR			
148K2		103	RH AFT CABIN	482	20	50R				CAUTION PNL (WITHOUT 74)			
031J1	MS3470W12-10S	17	PYLON, AFT CYCLIC PITCH ACT	528	130	12L	232P1	MS3476W22-55S	27	CONSOLE — CTR INSTR PNL — MASTER CAUTION			
031J2	MS3474W10-6S	15	CONTROLS CLOSET	118	-25	22L				PANEL (WITH 74)			
031J5	MS3474W10-6S	15	CONTROLS CLOSET	118	-25	22L	232P2	MS3476W16-26S	24	CONSOLE — CTR INSTR PNL — MASTER CAUTION			
031J6	MS3474W10-6S	15	CONTROLS CLOSET	118	-25	26L				PANEL (WITH 74)			
031J9	MS3474W10-6S	15	CONTROLS CLOSET	118	-25	24L							
031J11	MS3474W10-6S	15	CONTROLS CLOSET	95	-10	18L							
031J12	MS3474W10-6S	15	CONTROLS CLOSET	95	-10	18L							
031J21	MS3119E12-10	17	FWD XMSN AREA, FWD CYCLIC PITCH ACT	100	65	12L							
031P3	MS3476W24-61SX	28	ELECTRONICS COMP, NO. 1 AFCS, J3										
031P4	MS3476W24-61SX	28	ELECTRONICS COMP, NO. 2 AFCS, J3										
031P7	MS3476W14-19SX	21	CONSOLE, AFCS CONTROL PNL										
031P8	MS3476W24-61S	28	ELECTRONICS COMP, NO. 1 AFCS, J1										
031P10	MS3476W24-61 S	28	ELECTRONICS COMP, NO. 2 AFCS, J1										
031P13	M83723-95A1415N	34	CONTROLS CLOSET, PITCH LWR CONT ACT										
031P14	M83723-95A1415N	34	CONTROLS CLOSET, PITCH LWR CONT ACT										

GO TO NEXT PAGE

FLIGHT SYSTEM ELECTRICAL COMPONENT LOCATION AND CONFIGURATION LIST (Continued)

REF DESIG	PART NUMBER	TYPE	MATE WITH/LOCATION	STATION LOCATION			REF DESIG	PART NUMBER	TYPE	MATE WITH/LOCATION	STATION LOCATION		
				FS	WL	BL					FS	WL	BL
300J2	M83723-74A2255N	42	NO. 1 PDP				300J50	M83723-73A2461N	43	ELECTRONICS COMPARTMENT	120	40	20L
300P2	M83723-75A2255N	42	NO. 1 PDP				300P50	M83723-76A2461N	43	ELECTRONICS COMPARTMENT	120	40	20L
300J3	M83723-74A22556	42	NO. 1 PDP				300J51	M83723-74A2461N	43	AFT CROWN-OVHD	460	45	20R
300P3	M83723-75A22556	42	NO. 1 PDP				300P51	M83723-75A2461N	43	AFT CROWN-OVHD	460	45	20R
300J4	M83723-74A2461N	43	NO. 1 PDP				300J54	M83723-74A2461N	43	AFT CROWN-OVHD	460	50	20L
300P4	M83723-75A2461N	43	NO. 1 PDP				300P54	M83723-75A2461N	43	AFT CROWN-OVHD	460	50	20L
300J7	M83723-74A2255N	42	NO. 2 PDP				300J58	M83723-73A22558	42	CONSOLE-UNDERFLOOR DISCONNECT	85	-20	
300P7	M83723-75A2255N	42	NO. 2 PDP				300P58	M83723-76A22558	42	CONSOLE-UNDERFLOOR DISCONNECT	85	-20	
300J8	M83723-74A2461N	42	NO. 2 PDP				300J59	M83723-74A22556	42	CONSOLE-UNDERFLOOR DISCONNECT	85	-20	
300P8	M83723-75A2461N	42	NO. 2 PDP				300P59	M83723-75A22556	42	CONSOLE-UNDERFLOOR DISCONNECT	85	-20	
300J21	M83723-74A2461N	43	OVERHEAD PANEL-COCKPIT				300J60	M83723-74A22557	42	CONSOLE-UNDERFLOOR DISCONNECT	85	-20	
300P21	M83723-75A2461N	43	OVERHEAD PANEL-COCKPIT				300P60	M83723-75A22557	42	CONSOLE-UNDERFLOOR DISCONNECT	85	-20	
300J25	MS3474W16-26S	24	COCKPIT, UNDERFLOOR, PLT SIDE	70	-20	12R	300J61	M83723-73A24619	43	CONSOLE-UNDERFLOOR DISCONNECT	85	-20	
300P25	MS3476W16-26P	24	COCKPIT, UNDERFLOOR, PLT SIDE	70	-20	12R							
300J26	MS3474W16-26S	24	COCKPIT, UNDERFLOOR, CPLT SIDE	70	-30	40L	300J61	M83723-73W24619	28	CONSOLE-UNDERFLOOR DISCONNECT (WITHOUT 74)	85	-20	
300P26	MS3476W16-26P	24	COCKPIT, UNDERFLOOR, CPLT SIDE	70	-30	40L							
300J29	MS3474W14-19S	21	COCKPIT, UNDERFLOOR, PLT SIDE	65	-27	25R	300P61	M83723-76A24619	43	CONSOLE-UNDERFLOOR DISCONNECT (WITH 74)	85	-20	
300P29	MS3476W14-19P	21	COCKPIT, UNDERFLOOR, PLT SIDE	65	-27	25R							
300J30	MS3474W14-19S	21	COCKPIT, UNDERFLOOR, CPLT SIDE	70	-27	25L	300P61	M83723-76W24619	28	CONSOLE-UNDERFLOOR DISCONNECT (WITH 74)	85	-20	
300J44	M83723-74A2461N	43	AFT PYLON	520	72	15L							
300P44	M83723-75A2461N	43	AFT PYLON	520	72	15L							
300J45	M83723-73A2461N	43	HEATER COMPARTMENT	105	40	30R							
300P45	M83723-76A2461N	43	HEATER COMPARTMENT	105	40	30R							

FLIGHT SYSTEM ELECTRICAL COMPONENT LOCATION AND CONFIGURATION LIST (Continued)

RECEPTACLE

PLUG

RECEPTACLE

PLUG

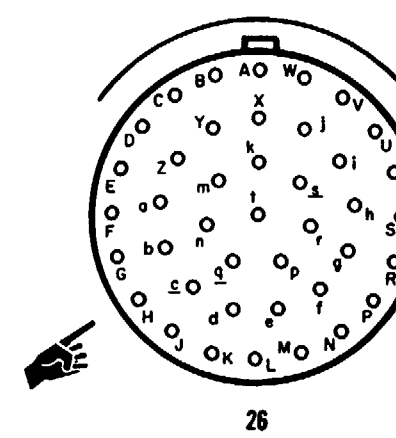
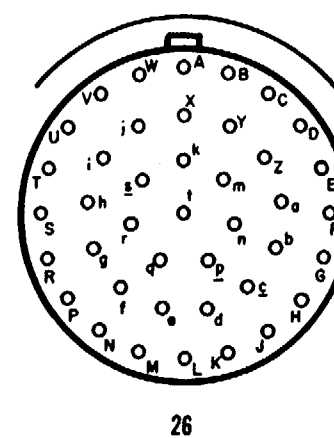
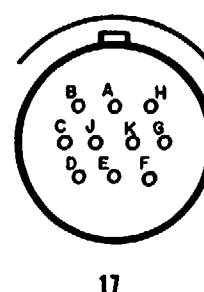
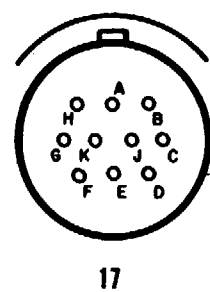
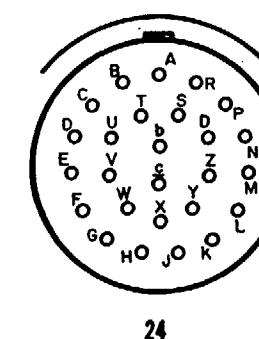
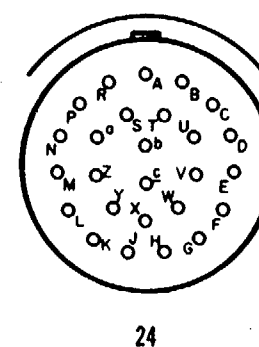
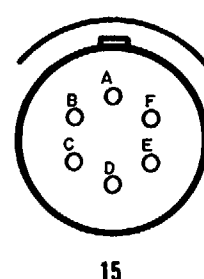
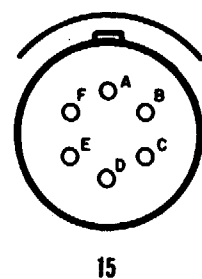
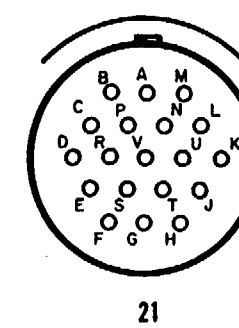
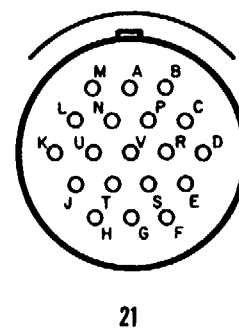
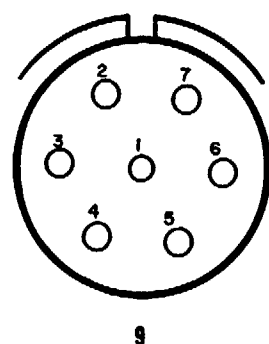
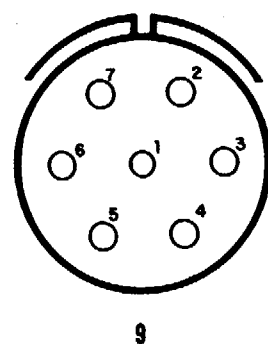

FLIGHT SYSTEM ELECTRICAL COMPONENT LOCATION AND CONFIGURATION LIST (Continued)

RECEPTACLE

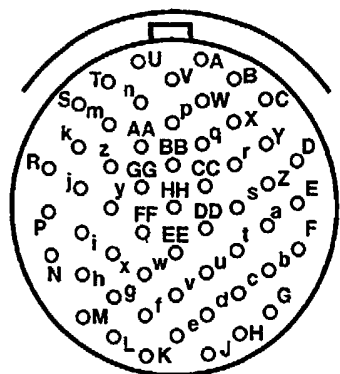

27

PLUG

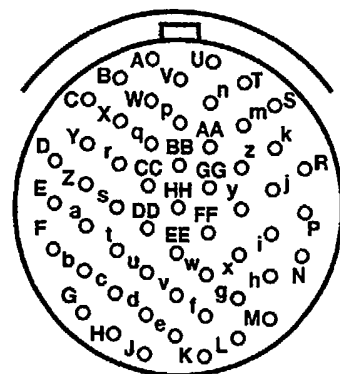

27

RECEPTACLE

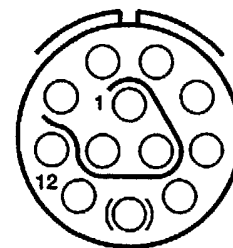

31

PLUG

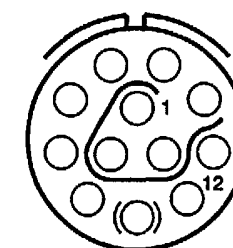

31

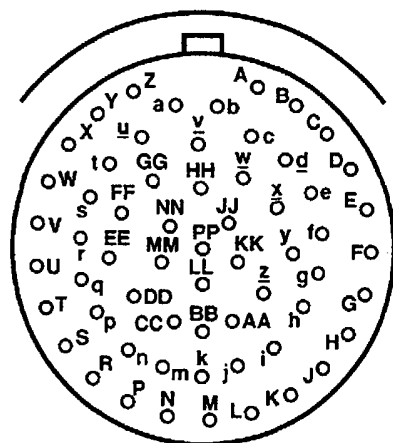

28

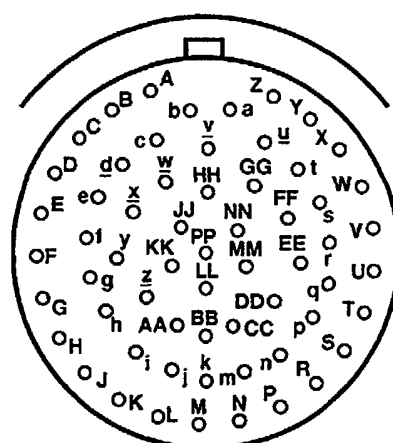

28

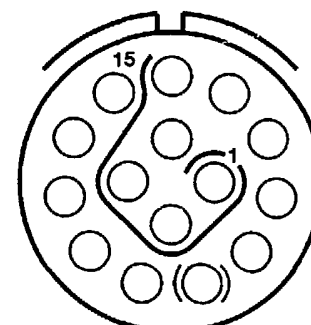

34

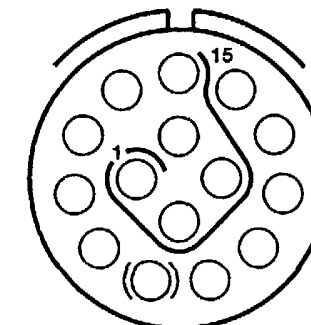

34



29



29

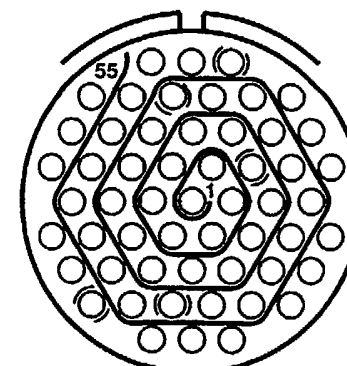

42

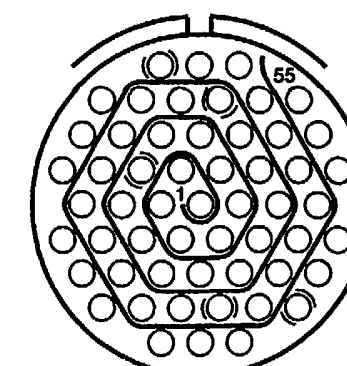

42

A69742

FLIGHT SYSTEM ELECTRICAL COMPONENT LOCATION AND CONFIGURATION LIST (Continued)

RECEPTACLE

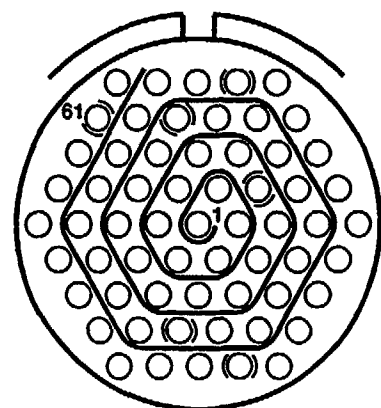

43

PLUG

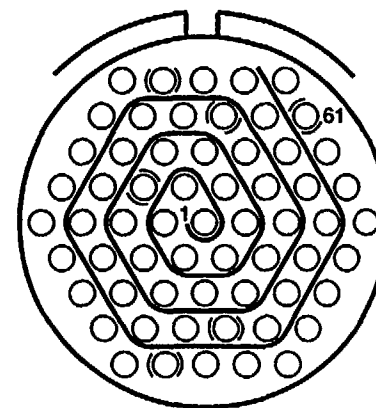

43

RELAY

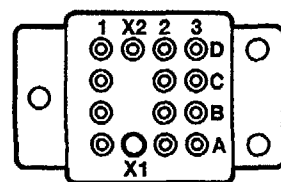

103

GND MODULE

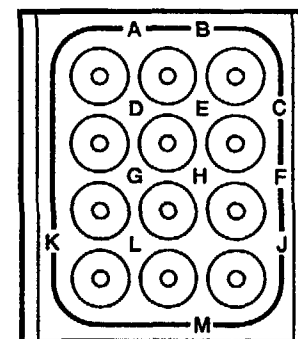

150

GND STUD



151

A67626

11-1 FLIGHT CONTROL SYSTEM

11-1 FLIGHT CONTROL SYSTEM

11-1.1 FLIGHT CONTROL SYSTEM SCHEMATIC

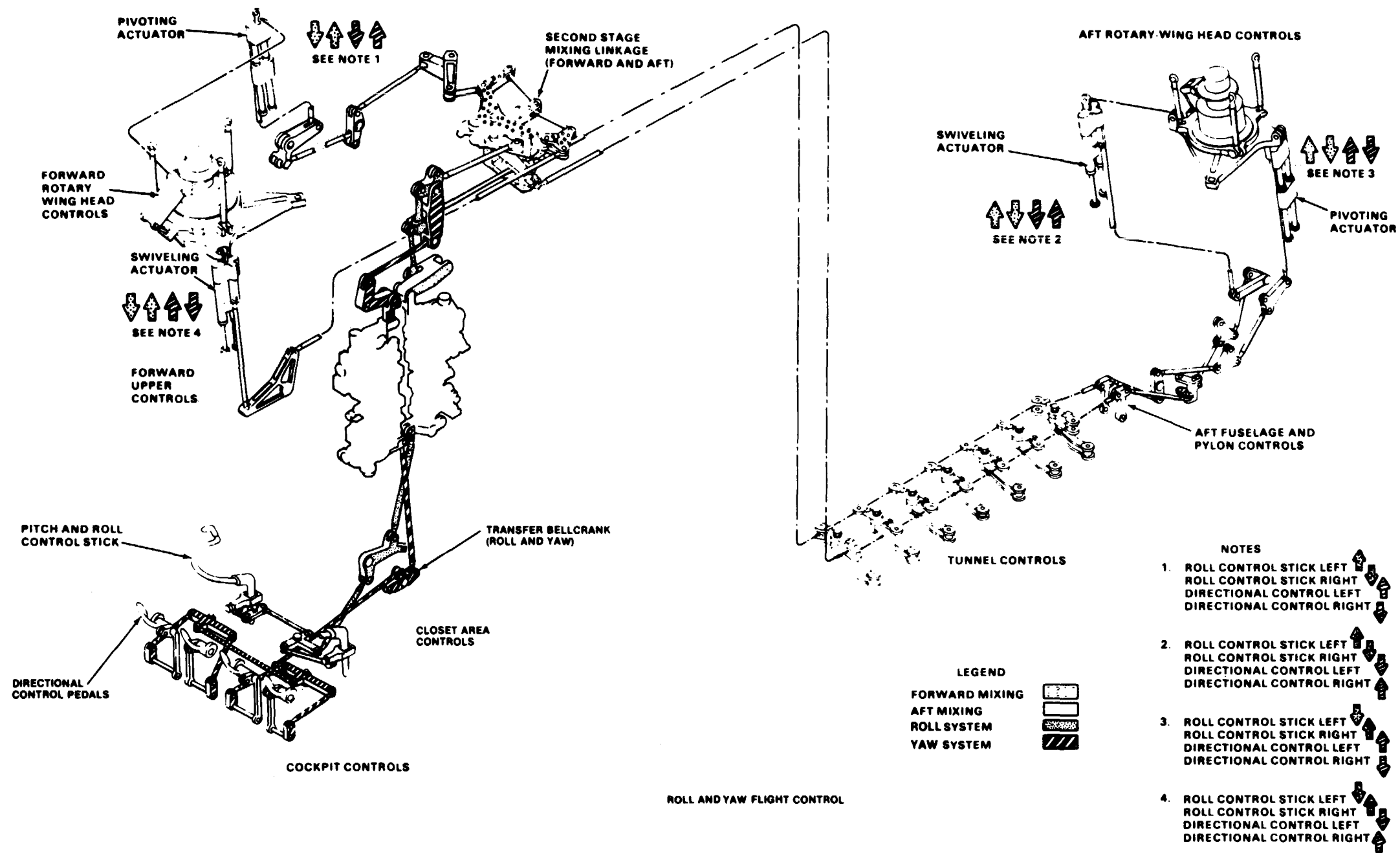

11-1.1 FLIGHT CONTROL SYSTEM SCHEMATIC (Continued)

11-1.1

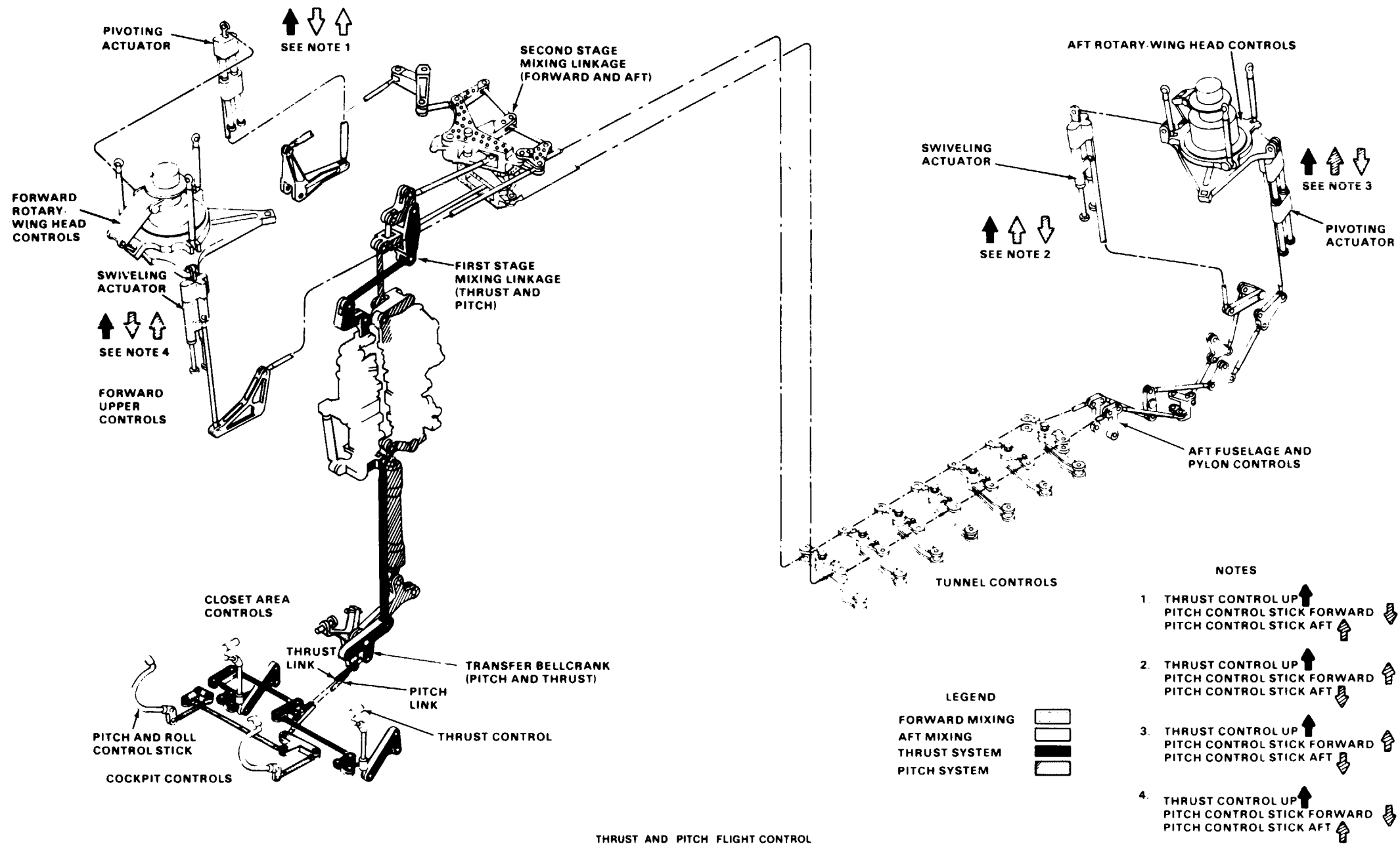

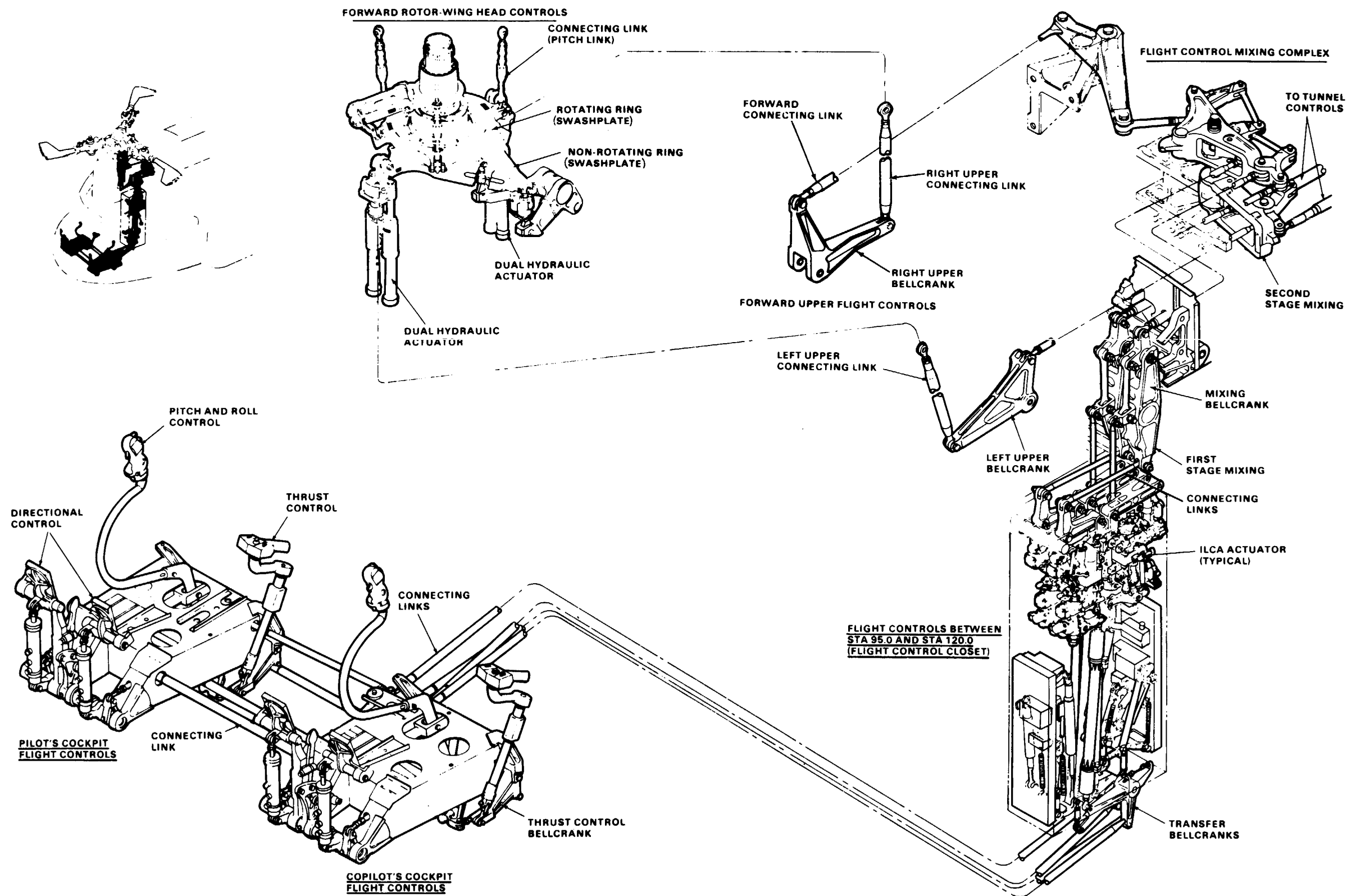

90x54

DI45-11965-SPA

GO TO NEXT PAGE

11-1.2 FLIGHT CONTROL SYSTEM CONNECTION DIAGRAM
(Continued)

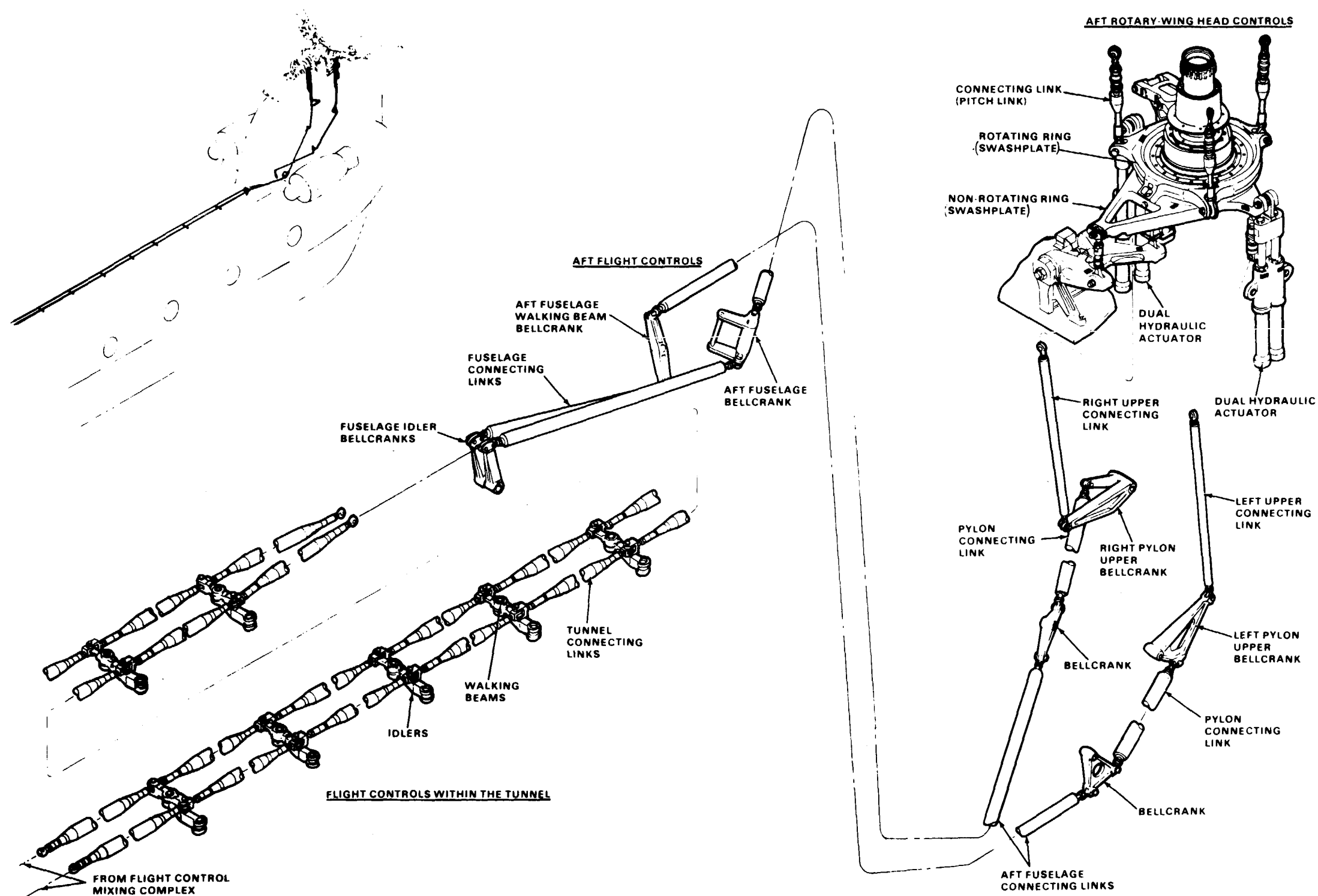

90.54

D145-11966-SPA

END OF TASK

11-5

INITIAL SETUP

Applicable Configurations:

All

Tools:

None

Materials:

None

Personnel Required:

Medium Helicopter Repairer (2)

References:

TM 55-1520-240-23

Equipment Condition:

TM 55-1520-240-23:

- Flight Control Closet Acoustic Blanket Removed
- Flight Control Closet Backup Panel Removed
- Forward Work Platform Open
- Pylon Work Platform Open
- Tunnel Covers Open
- One Aft Blade Positioned Behind and Off Helicopter Centerline
- Battery Connected
- Electrical Power On
- Hydraulic Power On

General Safety Instructions:

WARNING

Keep head, hands, and other body parts clear of moving flight controls. Hydraulic forces are strong enough to cause severe injury.

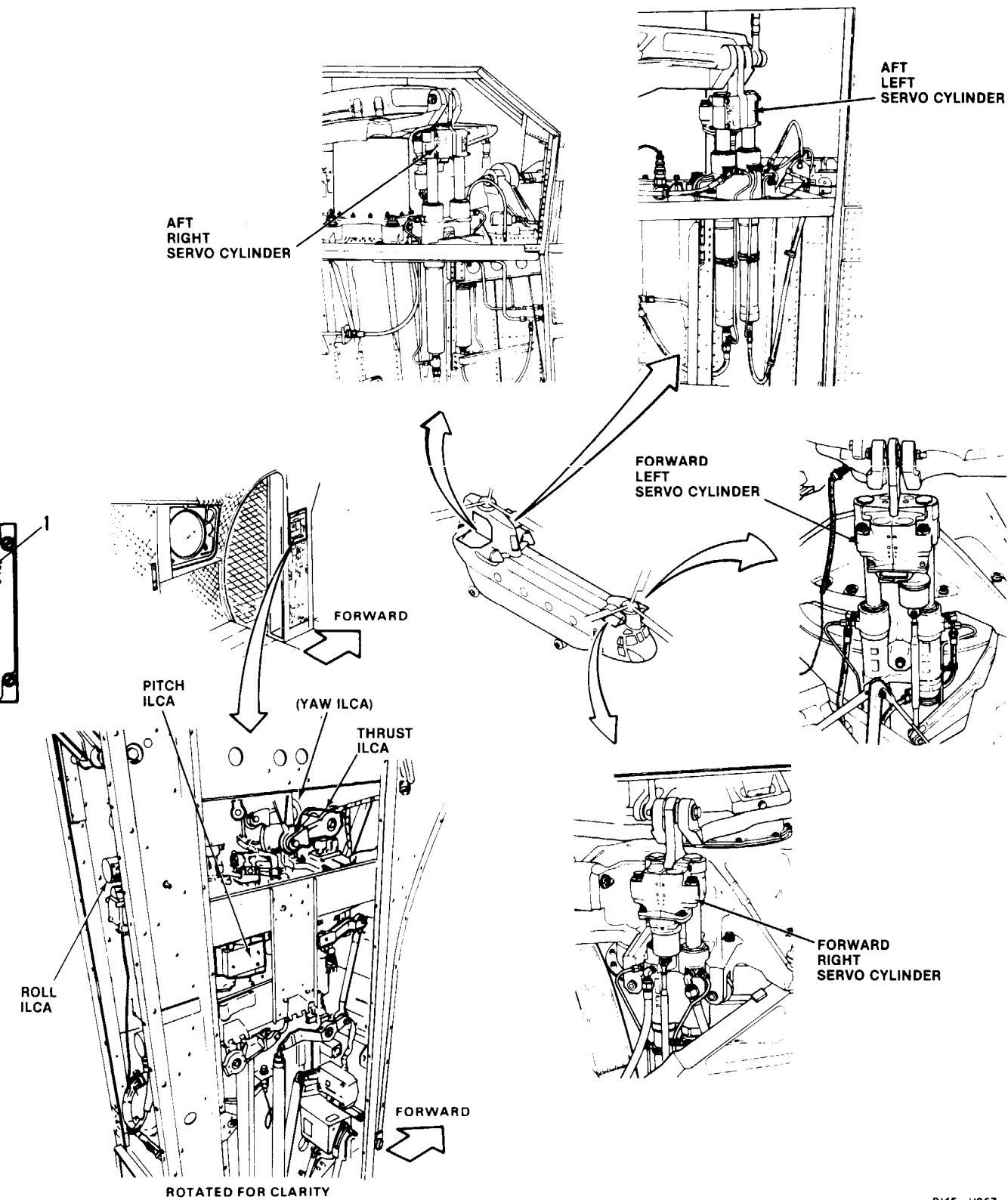
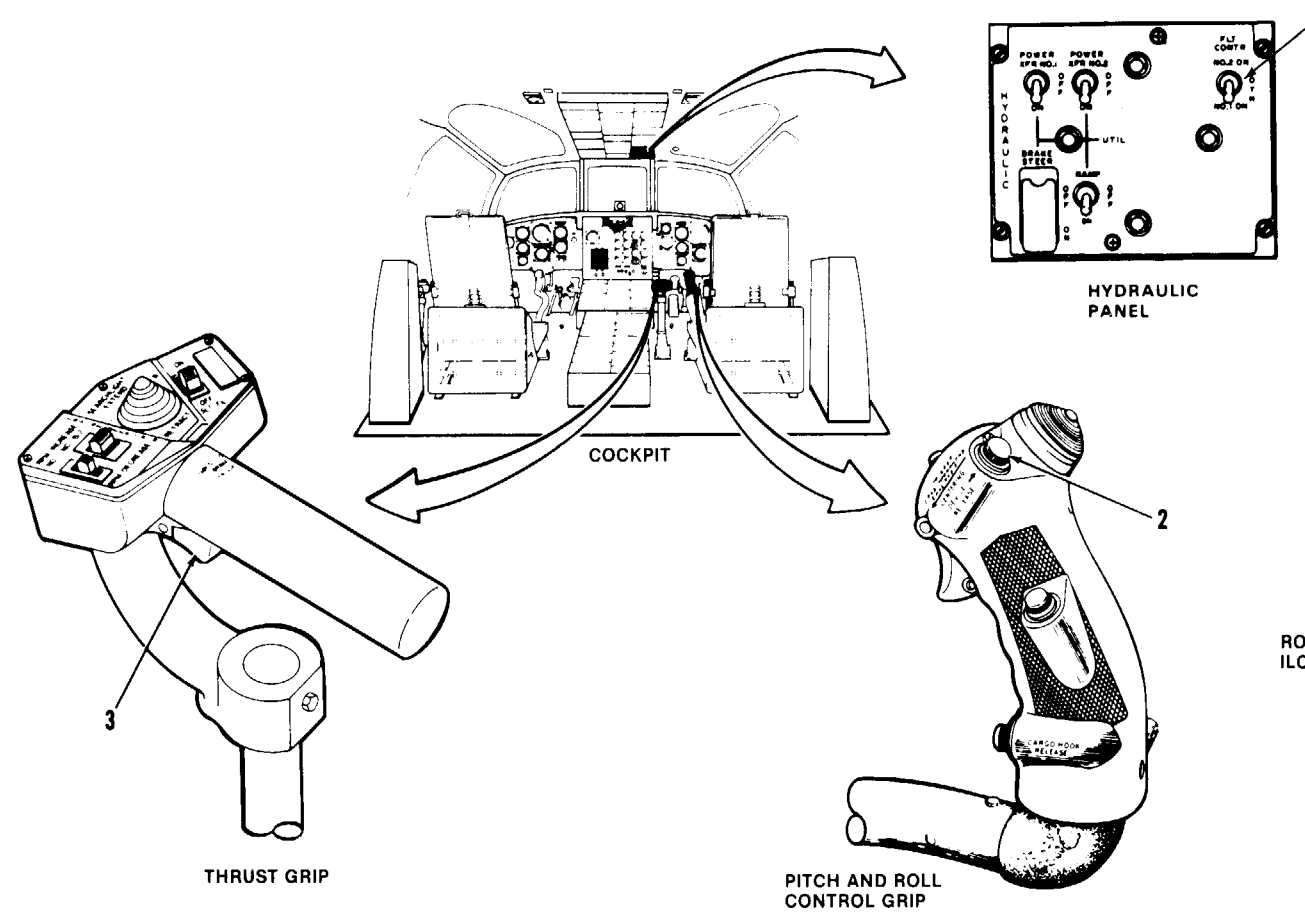

TASK	RESULT	FOLLOW-ON MAINTENANCE:
<ol style="list-style-type: none"> 1. Set FLT CONTR switch (1) to NO. 1 ON. 2. Press pilot CENTERING DEVICE RELEASE switch (2). Press pilot CP BRAKE TRIGGER switch (3). Move pilot pitch and roll control grip in a box pattern. Move pilot thrust grip up and down. Move pilot directional pedals forward and aft. Check all flight controls as cockpit controls are being moved. 	<p>Control travel shall be smooth and easy.</p> <p>Hydraulic fluid leakage shall not exceed that specified in TM 55-1520-240-23.</p> <p>If control travel is stiff or binding, check controls for interference or defective bearings. Correct interference or replace defective bearings.</p> <p>If unusual noises are heard, replace noisy component.</p>	<p>TM 55-1520-240-23:</p> <ul style="list-style-type: none"> Hydraulic power off. Electrical power off. Battery disconnected. Flight control closet backup panel installed. Flight control closet acoustic blanket installed. Tunnel covers closed. Pylon work platforms closed. Forward work platforms closed.
<ol style="list-style-type: none"> 3. Release pilot CENTERING DEVICE RELEASE switch (2) and CP BRAKE TRIGGER switch (3). 4. Set FLT CONTR switch (1) to NO. 2 ON. 5. Repeat step 2 and step 3, then go to step 6. 6. Set FLT CONTR switch (1) to BOTH. 7. Press pilot CENTERING DEVICE RELEASE switch (2). Press pilot CP BRAKE TRIGGER switch (3). Move thrust control down to detent. Move pitch and roll control and pedals to neutral. Release CENTERING DEVICE RELEASE and CP BRAKE TRIGGER switches (2 and 3). 	<p style="text-align: center;">NOTE</p> <p>It is not unusual for swashplate slider bearings to make some noise and chatter during ground operational checks.</p> <p>If hydraulic fluid is observed, refer to TM 55-1520-240-23 to determine allowable leakage.</p>	

11-2 ARTIFICIAL FEEL - MAGNETIC BRAKES

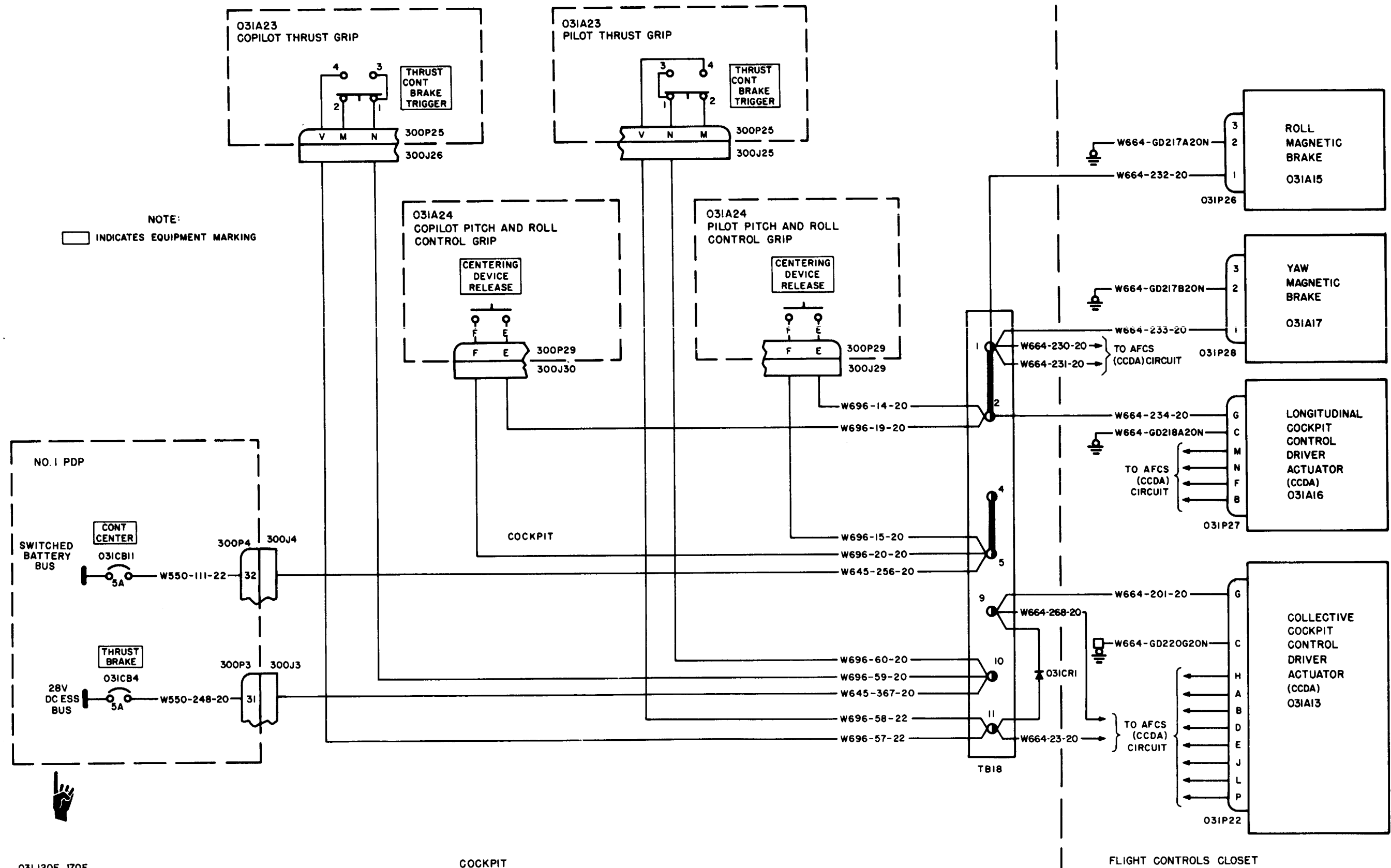

031.120F, .170F

COCKPIT

FLIGHT CONTROLS CLOSET

INITIAL SETUP

Applicable Configurations:

All

Tools:

Aircraft Mechanic's Tool Kit,
NSN 5180-00-323-4692

Materials:

None

Personnel Required:

Medium Helicopter Repairer

References:

TM 55-1520-240-23

Equipment Condition:

- TM 55-1520-240-23:
- Battery Disconnected
- Electrical Power Off
- Hydraulic Power Off
- Flight Controls Closet - Insulation Blanket Removed
- Flight Controls Closet Panel Opened

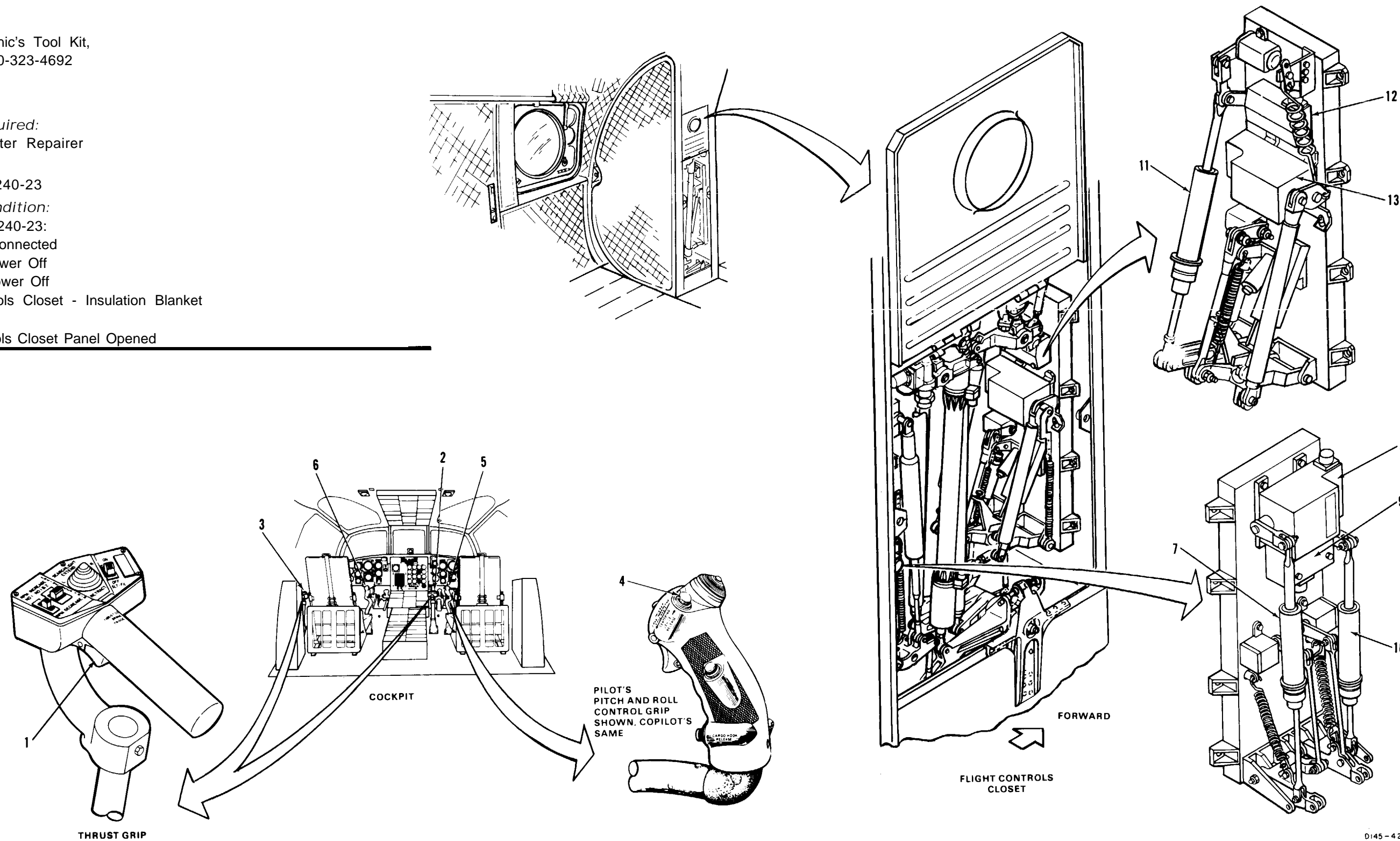

D145-4213-SPA

GO TO NEXT PAGE

TASK	RESULT	TASK	RESULT
1. Check THRUST CONT BRAKE TRIGGER switch (1) on pilot's and copilot's thrust grips (2 and 3).	If either switch (1) is damaged, replace it.	7. Check yaw centering spring (11) .	If centering spring (11) is bent or has damaged parts, replace it.
2. Check CENTERING DEVICE RELEASE switch (4) on pilot's and copilot's pitch and roll control grips (5 and 6).	If either switch (4) is damaged, replace it.	8. Check yaw magnetic brake (12) .	If brake (12) is loose or damaged, tighten or replace it as required. If wiring to brake is damaged, repair or replace it as required.
3. Check longitudinal centering spring (7) .	If centering spring (7) is bent or has damaged pans, replace it.	9. Check collective ccda (13) .	If ccda (13) is loose or damaged, tighten or replace it as required. If wiring to ccda is damaged, repair or replace it as required.
4. Check longitudinal cockpit control driver actuator (ccda) (8) .	If ccda (8) is loose or damaged, tighten or replace it as required. If wiring to ccda is damaged, repair or replace it as required.	FOLLOW-ON MAINTENANCE: None	
5. Check roll magnetic brake (9) .	If brake (9) is loose or damaged, tighten or replace it as required. If wiring to brake is damaged, repair or replace it as required.		
6. Check roll centering spring (10) .	If centering spring (10) is bent or has damaged parts, replace it.		

INITIAL SETUP

Applicable Configurations:

All

Tools:

None

Materials:

None

Personnel Required:

Medium Helicopter Repairer

References:

TM 55-1520-240-23

Equipment Condition:

TM 55-1520-240-23:

Battery Connected

Electrical Power On

Hydraulic Power On

Artificial Feel - Magnetic Brakes Visual Check Performed

TASK	RESULT
CHECK CIRCUIT BREAKERS	
1. Check that THRUST BRAKE circuit breaker (1) is closed.	If circuit breaker (1) is open, close it. If it opens again, go to task 11-2.4
2. Check that CONT CENTER circuit breaker (2) is closed.	If circuit breaker (2) is open, close it. If it opens again, go to task 11-2.5.
CHECK ARTIFICIAL FEEL AND PILOT CONTROL OF MAGNETIC BRAKES	
3. Press and hold pilot CENTERING DEVICE RELEASE switch (3). Center pilot pitch and roll control stick and directional pedals. Release CENTERING DEVICE RELEASE switch.	Control stick and directional pedals shall center easily and remain there after CENTERING DEVICE RELEASE switch (3) is released. If both control stick and directional pedals do NOT remain centered, go to task 11-2.6. If either control stick or directional pedals do not remain centered, continue operational check to identify problem.
4. Press and hold pilot CENTERING DEVICE RELEASE switch (3). Move pilot control stick through longitudinal travel range. Position control 1 inch forward of center position. Release switch.	Control stick shall move easily through longitudinal travel range and remain at selected position when switch (3) is released. If it does not, go to task 11-2.7.
5. Move pilot control stick <u>1 inch</u> forward and release control stick. Move pilot control stick <u>1 inch</u> aft and release control stick.	Control stick shall return to original position when control stick is released. If it does not, go to task 11-2.7

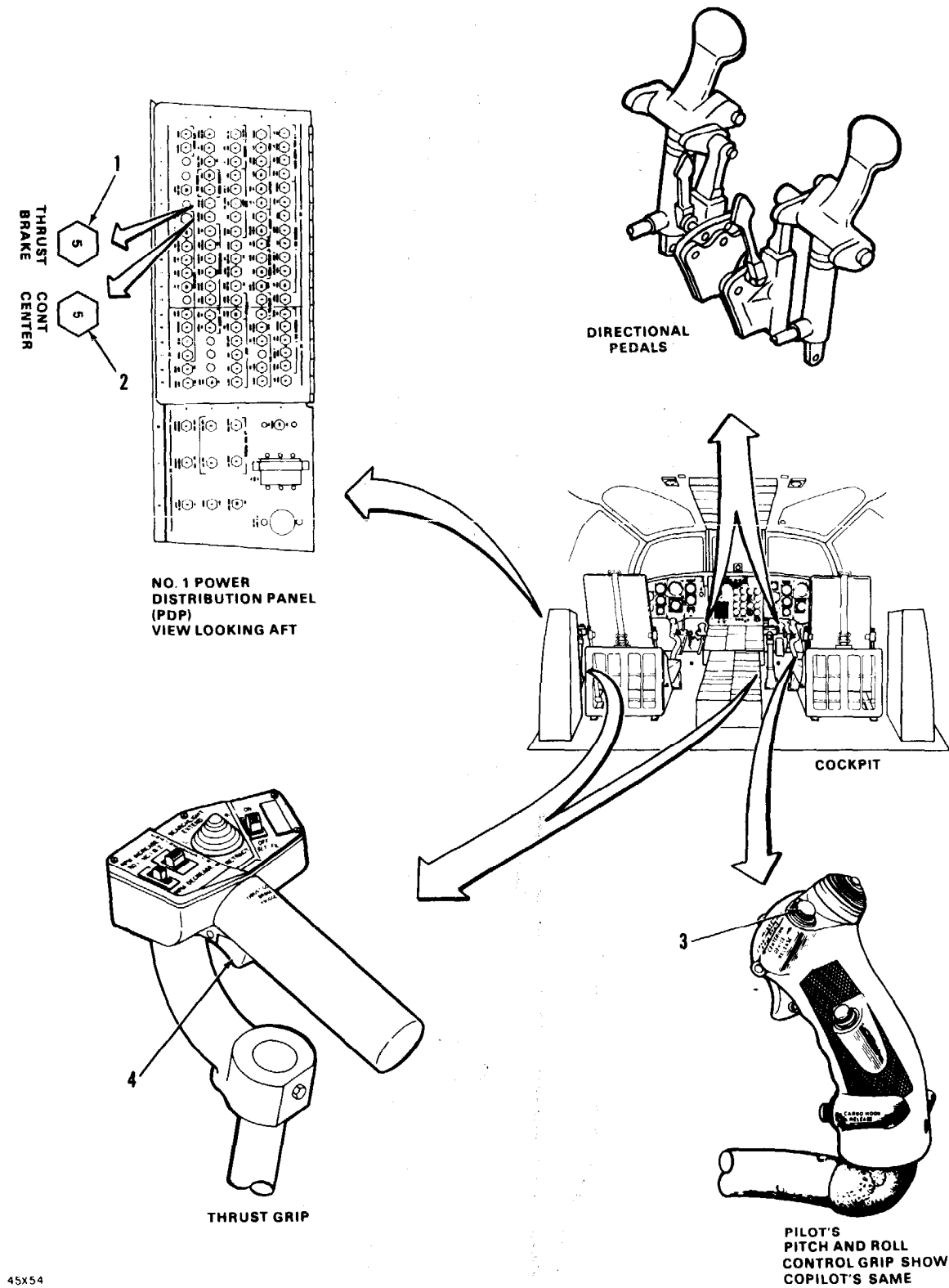

45X54

D145-4214-SPA

TASK	RESULT
6. Press and hold pilot's CENTERING DEVICE RELEASE switch (3). Move pilot's control stick through lateral travel range. Position control stick <u>1 inch</u> left of center position. Release switch.	Control stick shall move easily through lateral travel range and remain at selected position when switch (3) is released. If it does not, go to task 11-2.7.
7. Move pilot's control stick <u>1 inch</u> left and release control stick. Move pilot's control stick <u>1 inch</u> right and release control stick.	Control stick shall return to original position when control stick is released. If it does not, go to task 11-2.7.
8. Press and hold pilot's CENTERING DEVICE RELEASE switch (3). Move pilot's pedals through directional range. Position left pedal <u>1 inch</u> forward of center. Release switch.	Pedals shall move easily through directional range and remain at selected position when switch (3) is released. If they do not, go to task 11-2.8.
9. Move pilot's left pedal <u>1 inch</u> forward and release it. Move pilot's right pedal <u>1 inch</u> forward and release it.	Pedals shall return to original position when pedals are released. If they do not, go to task 11-2.8.
10. Press and hold pilot's THRUST CONT BRAKE TRIGGER switch (4). Move pilot's thrust control full up. Release switch.	Thrust control shall move easily to full up and remain there after switch (4) is released. If not, go to task 11-2.9.

TASK	RESULT
11. Press and hold pilot's THRUST CONT BRAKE TRIGGER switch (4). Move pilot's thrust control full down. Release switch.	Thrust control shall move easily and remain down after switch (4) is released. If not, go to task 11-2.9.
NOTE	
Thrust control down stop is spring loaded. Control will raise up from full down to a pre-determined position when released.	
<i>CHECK COPILOT CONTROL OF MAGNETIC BRAKES</i>	
12. Press and hold copilot's THRUST CONT BRAKE TRIGGER switch (4). Move copilot's thrust control from full down to full up and back to mid position. Release switch.	Thrust control shall move easily and remain at selected position after switch (4) is released. If not, go to task 11-2.10.
13. Press and hold copilot's CENTERING DEVICE RELEASE switch (3). Move copilot's pitch and roll control stick forward. Release switch.	Control stick shall remain at selected position after switch (3) is released. If it does not, go to task 11-2.11.
14. Move control stick to center position. Press and release CENTERING DEVICE RELEASE switch.	Control stick shall remain at center position.

FOLLOW-ON MAINTENANCE:

- TM 55-1520-240-23:
- Battery disconnected.
- Electrical power off.
- Hydraulic power off.
- Flight controls closet panel closed.
- Flight controls insulated blanket installed.

FAULT ISOLATION PROCEDURE

INITIAL SETUP

Applicable Configurations:

All

Tools:

- Electrical Repairer's Tool Kit,
NSN 5180-00-323-4915
- Multimeter

Materials:

None

Personnel Required:

68F20 Aircraft Electrician

References:

TM 55-1520-240-23

Equipment Condition:

- TM 55-1520-240-23
- Battery Disconnected
- Electrical Power Off
- Hydraulic Power Off
- Electronic Compartment Acoustic
Blanket Removed

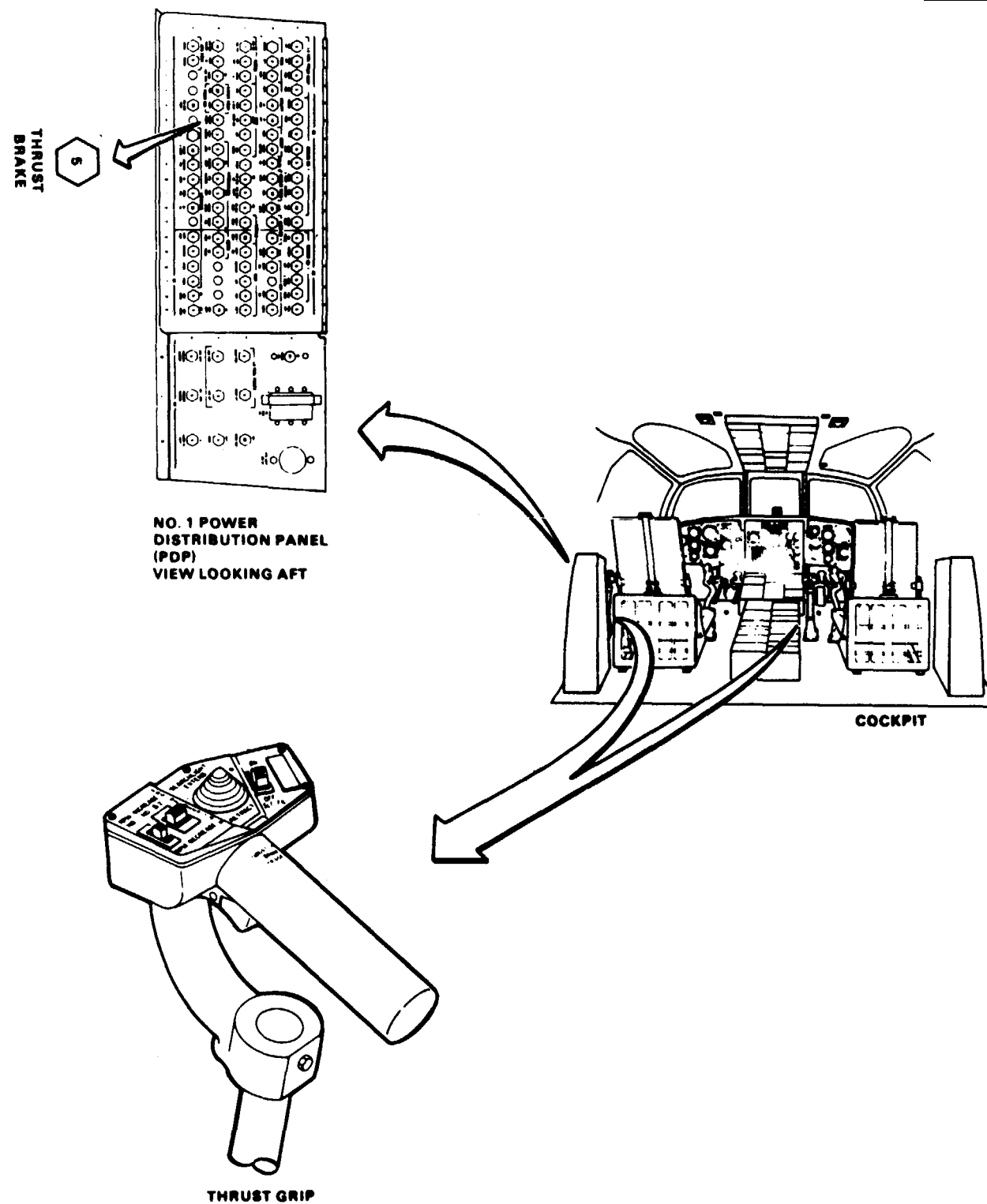
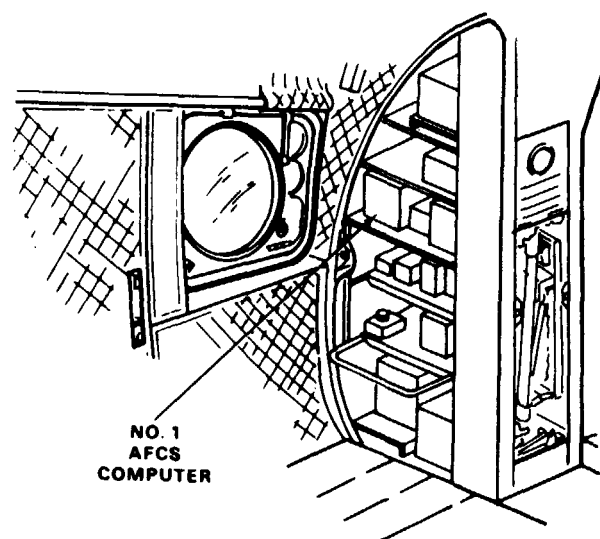

11-2.4 THRUST BRAKE CIRCUIT BREAKER DOES NOT STAY CLOSED (Continued)

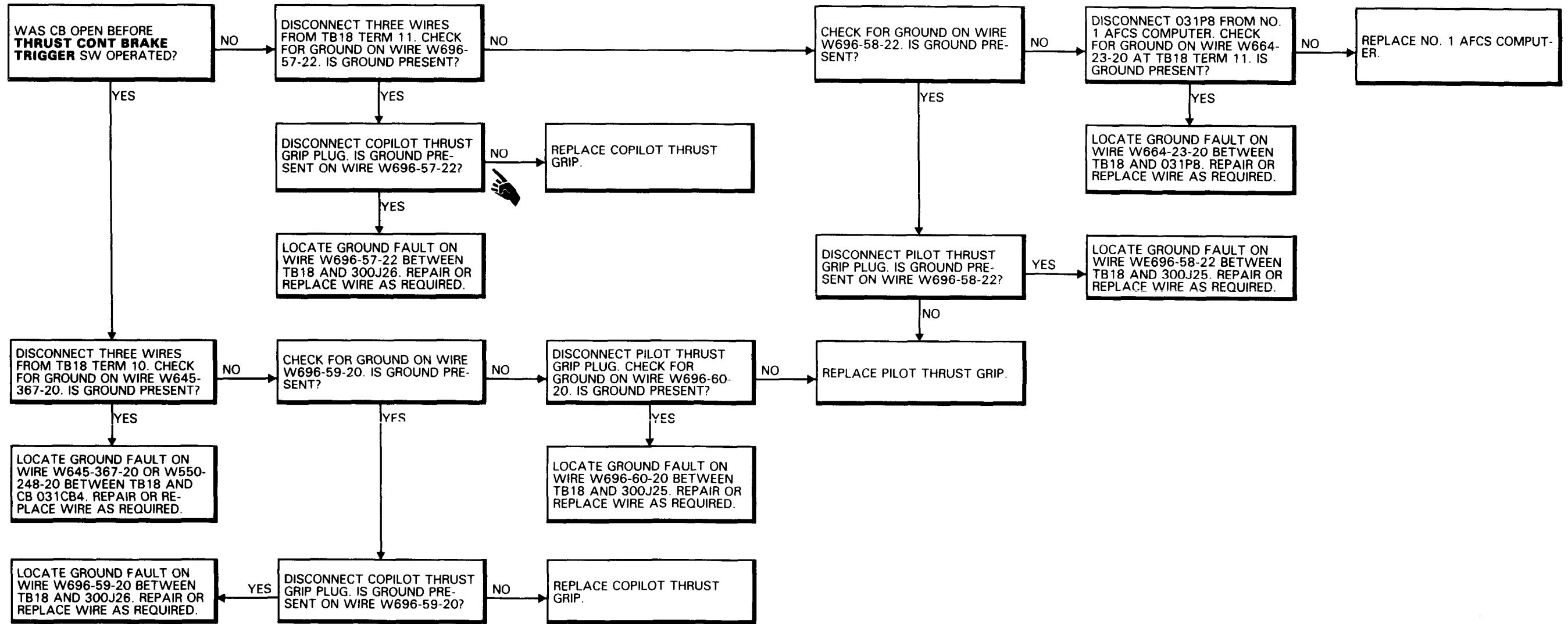

11-2.5 CONT CENTER CIRCUIT BREAKER DOES NOT STAY CLOSED

FAULT ISOLATION PROCEDURE

INITIAL SETUP

Applicable Configurations:
All

Equipment Condition:
TM 55-1520-240-23:
Battery Disconnected
Electrical Power Off
Hydraulic Power Off
Electronic Compartment Acoustic
Blanket Removed

Tools:

Electrical Repairer's Tool Kit,
NSN 5180-00-323-4915
Multimeter

Materials:

None

Personnel Required:

68F20 Aircraft Electrician

References:

TM 55-1520-240-23

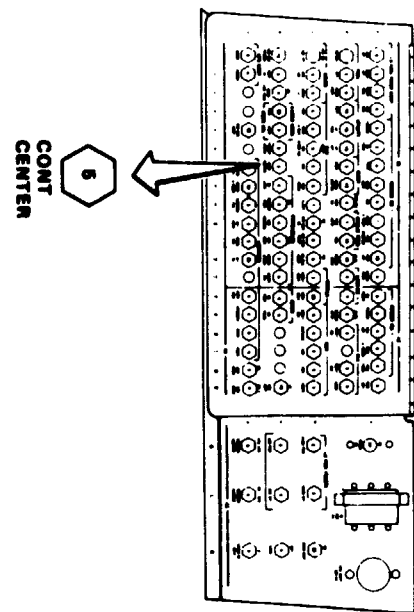
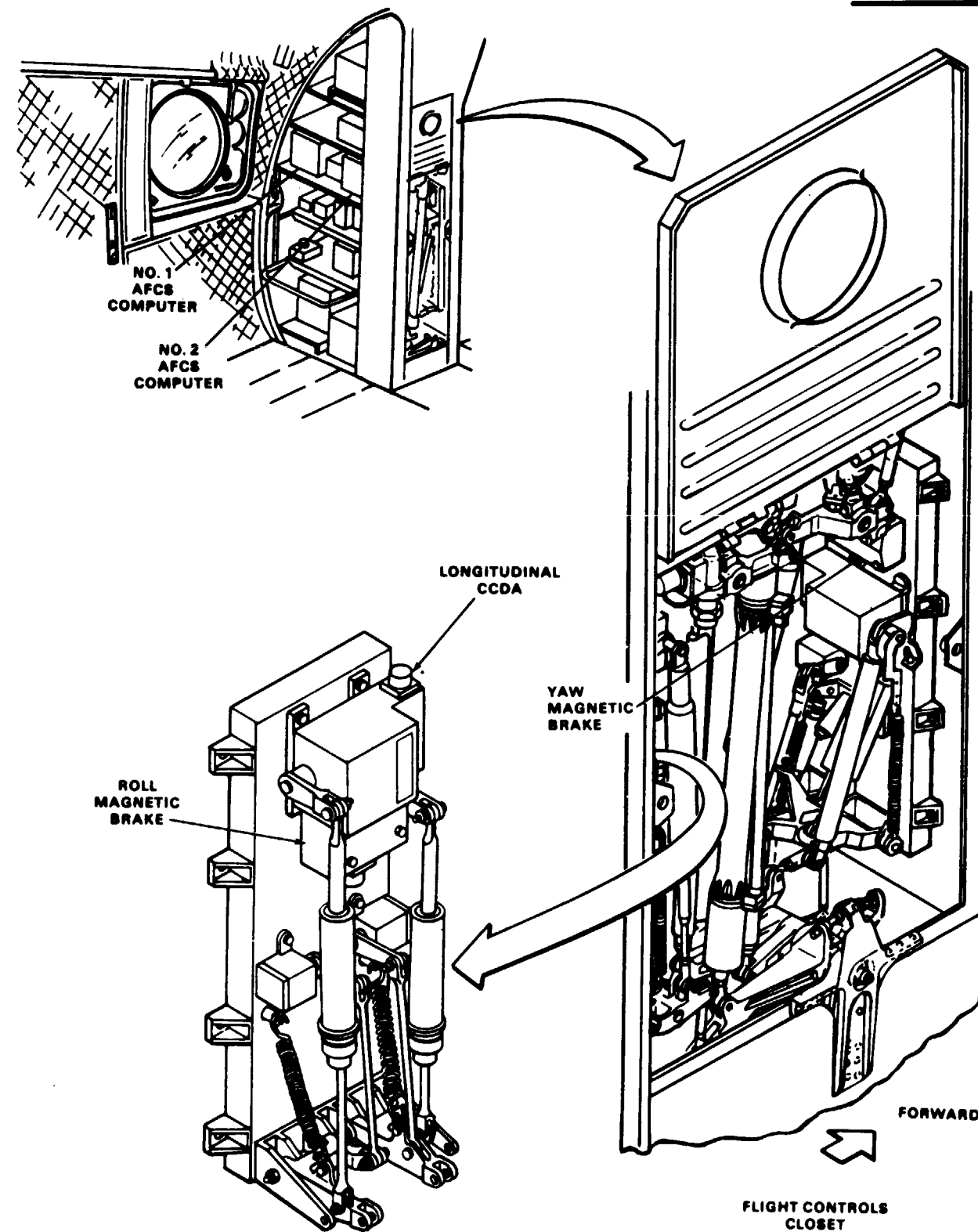

NO. 1 POWER DISTRIBUTION PANEL (PDP) VIEW LOOKING AFT

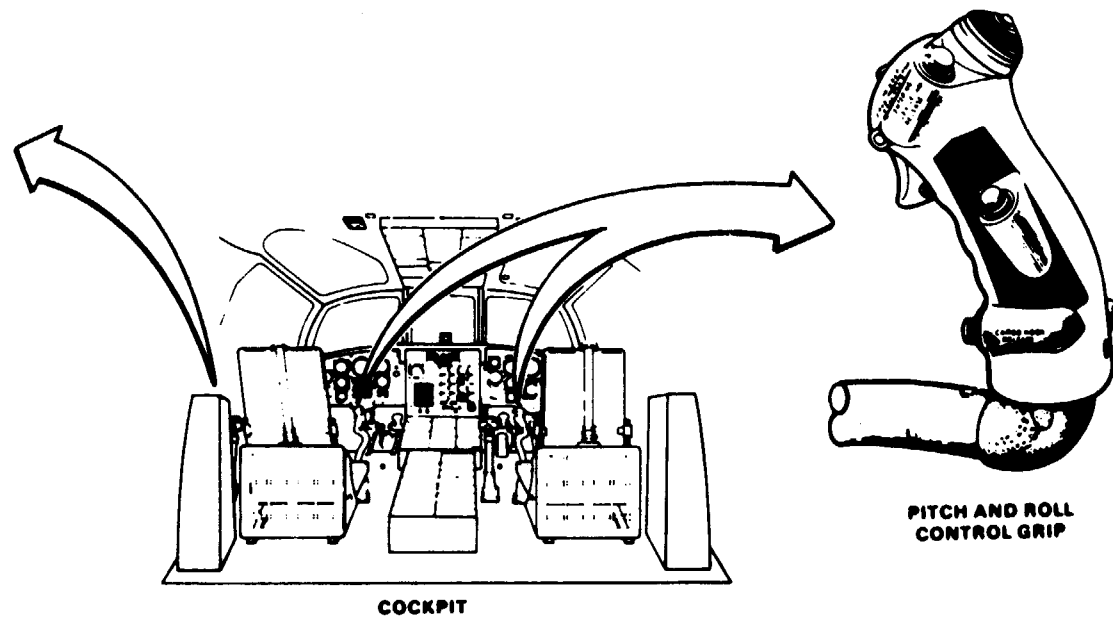

PITCH AND ROLL CONTROL GRIP

D145-4216-SPA

GO TO NEXT PAGE

11-2.5 CONT CENTER CIRCUIT BREAKER DOES NOT STAY CLOSED
(Continued)

11-2.5

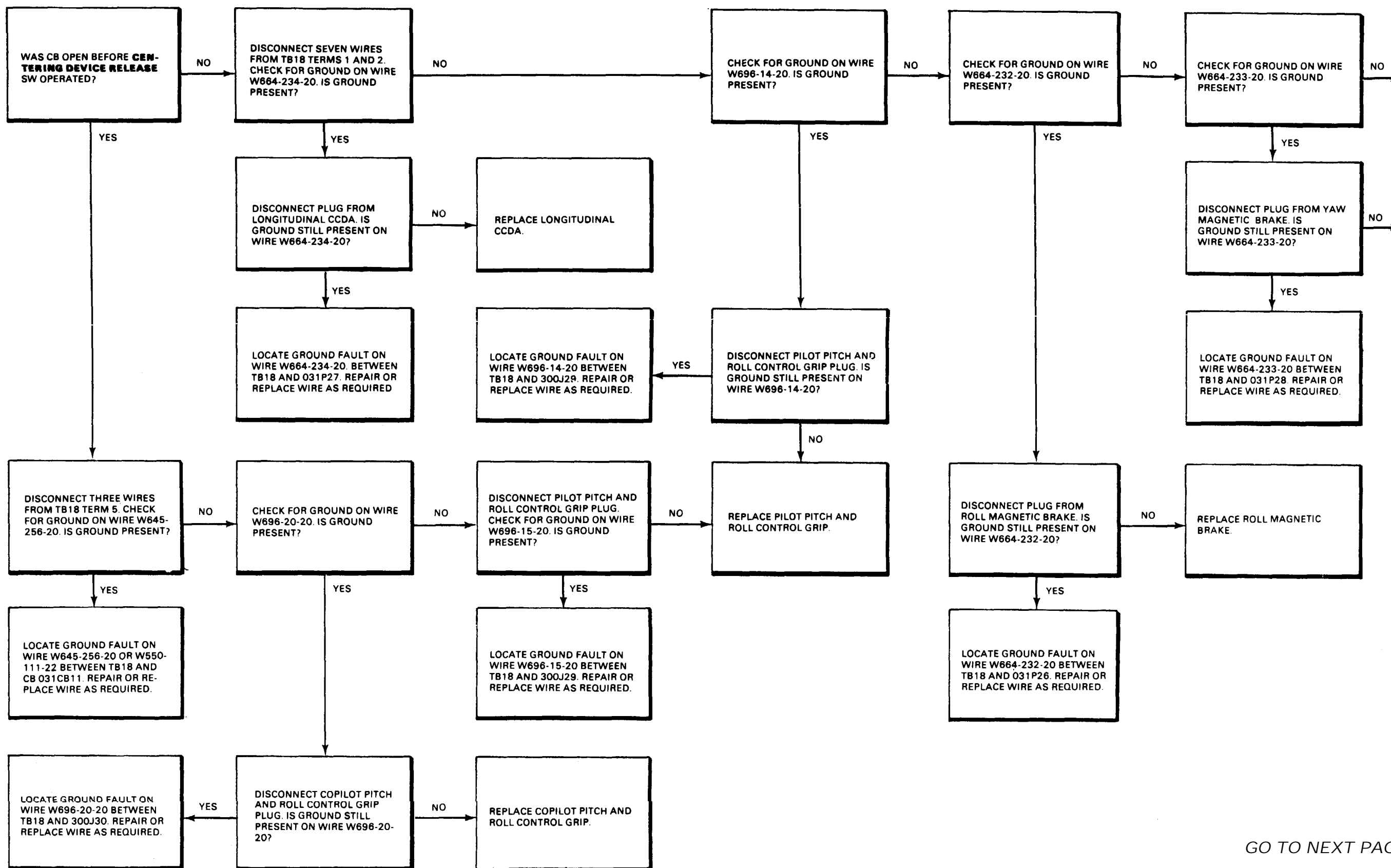

GO TO NEXT PAGE

11-2.5 CONT CENTER CIRCUIT BREAKER DOES NOT STAY CLOSED
(Continued)

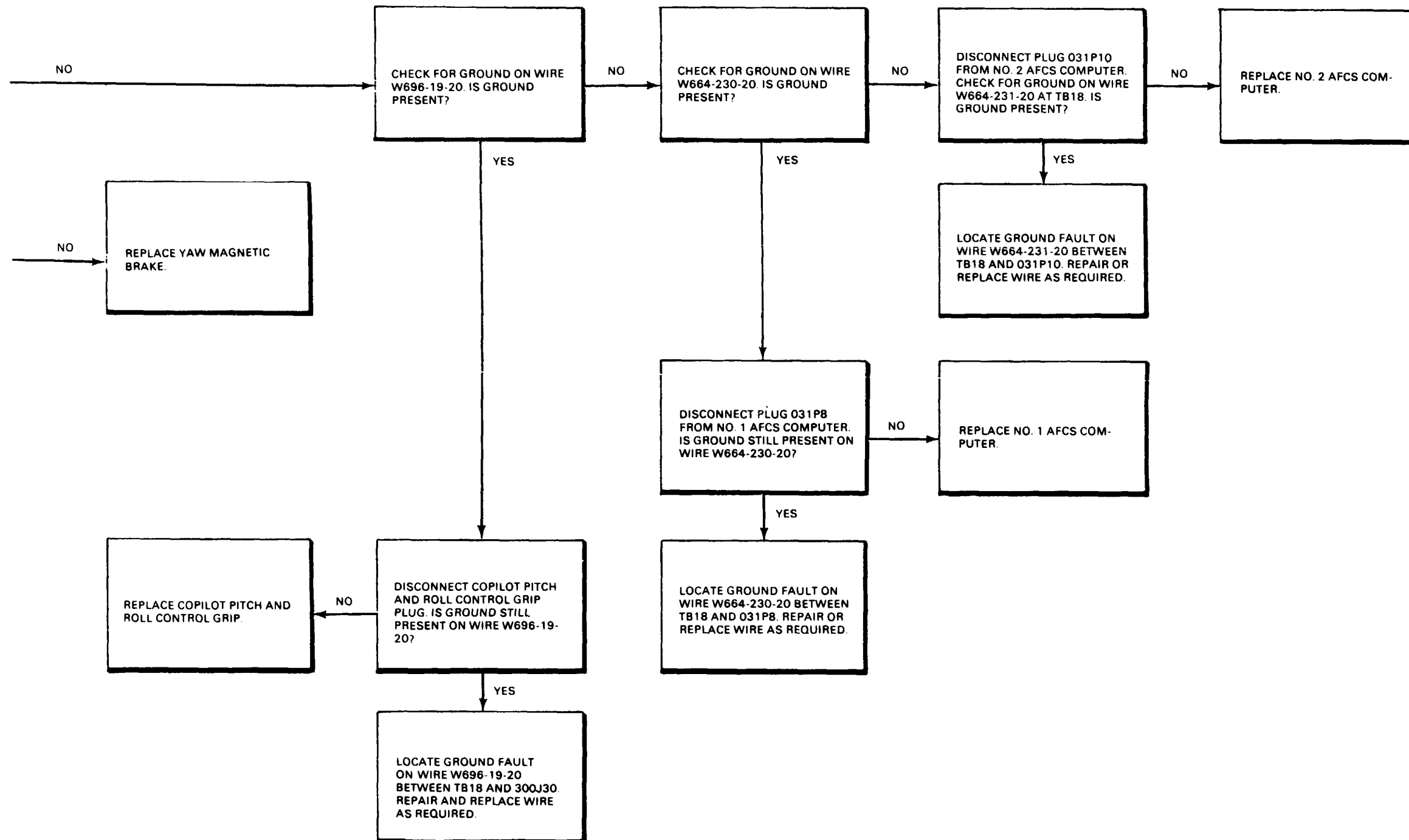

GO TO NEXT PAGE

11-2.5 CONT CENTER CIRCUIT BREAKER DOES NOT STAY CLOSED
(Continued)

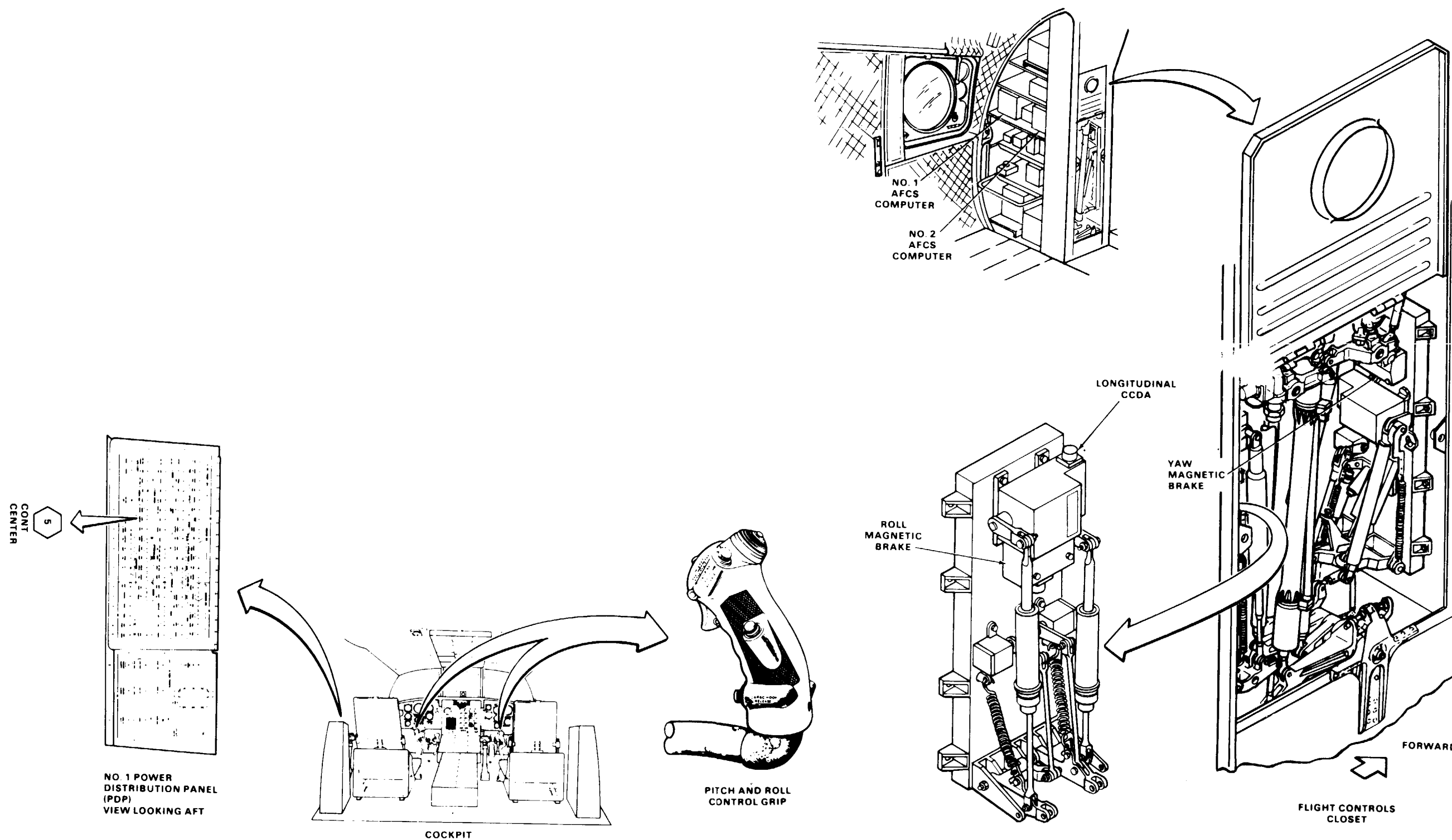

90 X 54

D145-11829-SPA

END OF TASK

11-2.6 CONTROL STICK AND PEDALS WILL NOT STAY CENTERED AFTER PILOT'S CENTERING DEVICE RELEASE SWITCH RELEASED

FAULT ISOLATION PROCEDURE

INITIAL SETUP

Applicable Configurations:

All

Tools:

- Electrical Repairer's Tool Kit,
NSN 5180-00-323-4915
- Multimeter

Materials:

None

Personnel Required:

- 67U10 Medium Helicopter Repairer
- 68F20 Aircraft Electrician

References:

TM 55-1520-240-23

Equipment Condition:

- TM 55-1520-240-23:
- Battery Connected
- Electrical Power On
- Hydraulic Power On

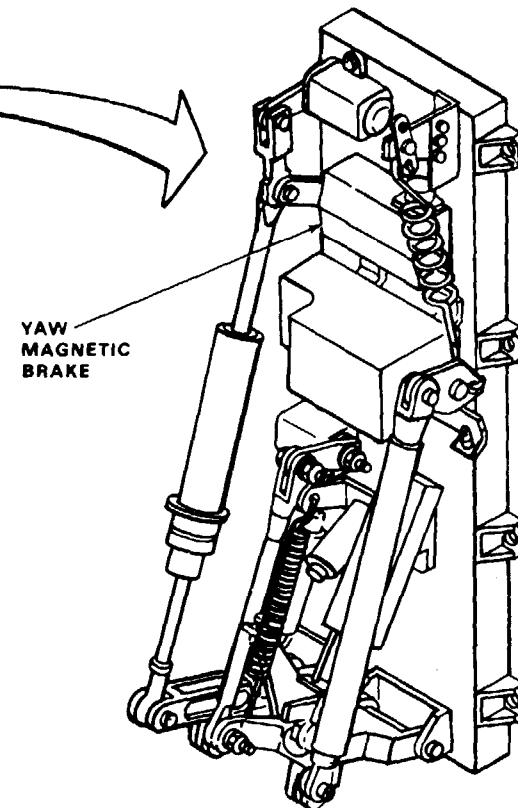
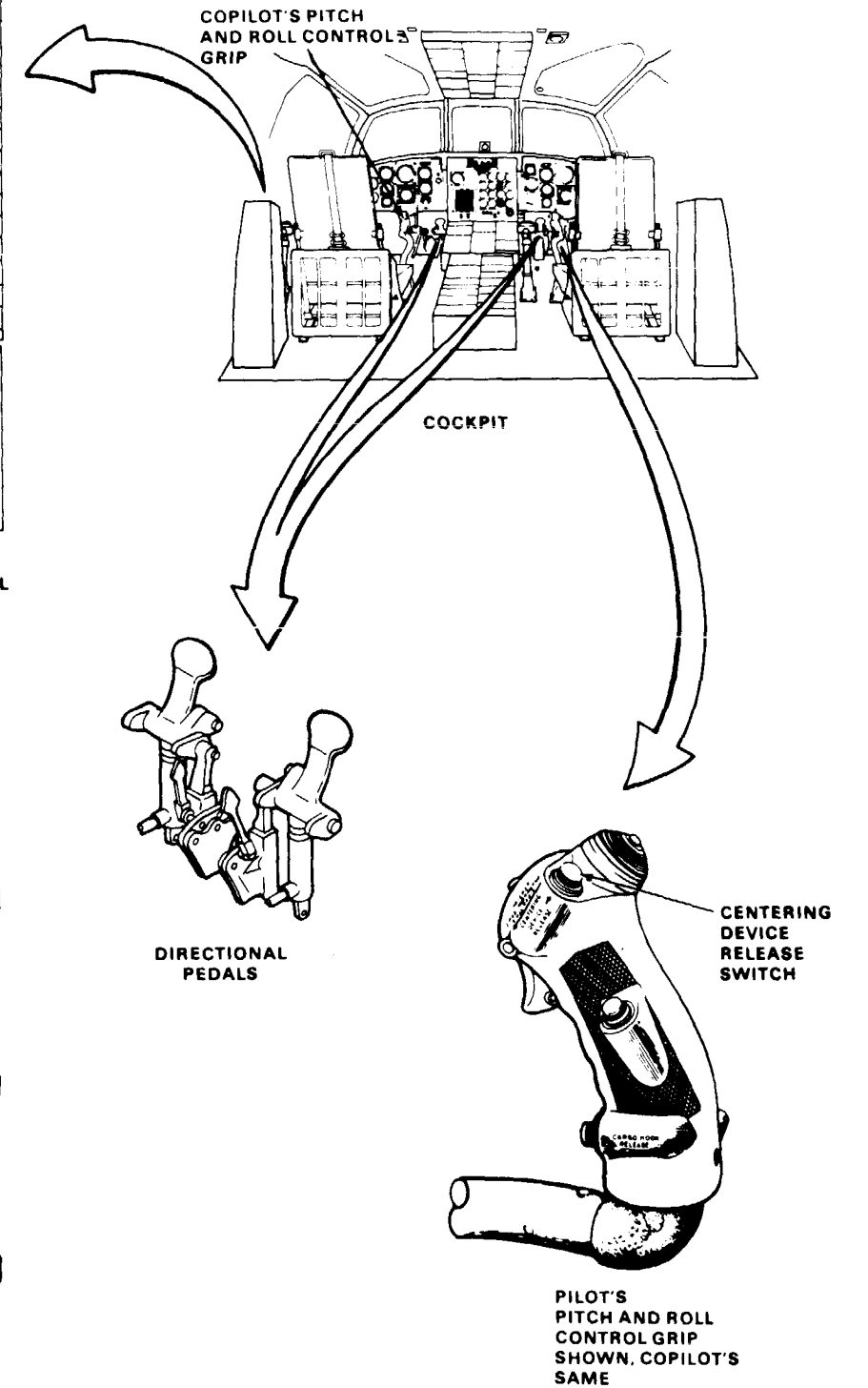
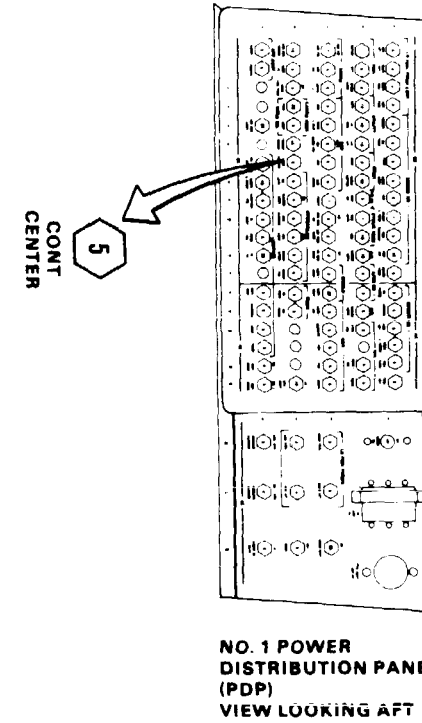
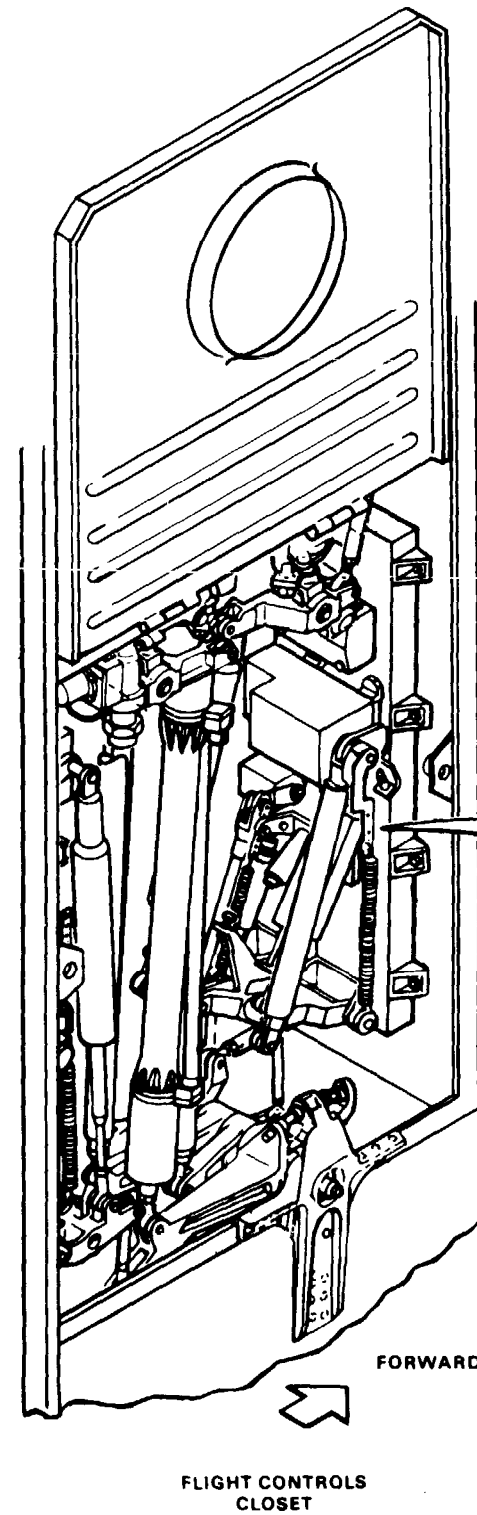
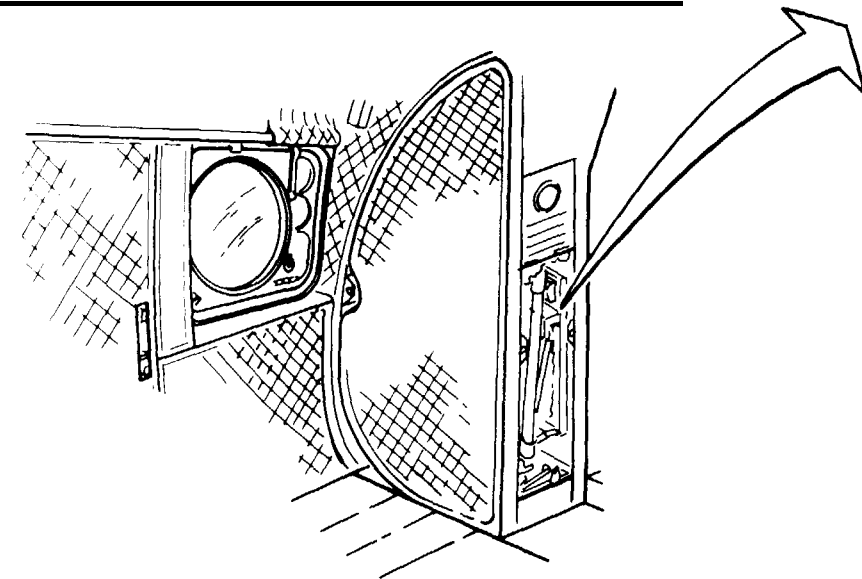

11-2.6 STICK AND PEDALS WILL NOT STAY CENTERED
 AFTER PILOT'S CENTERING DEVICE RELEASE SWITCH
 RELEASED (Continued)

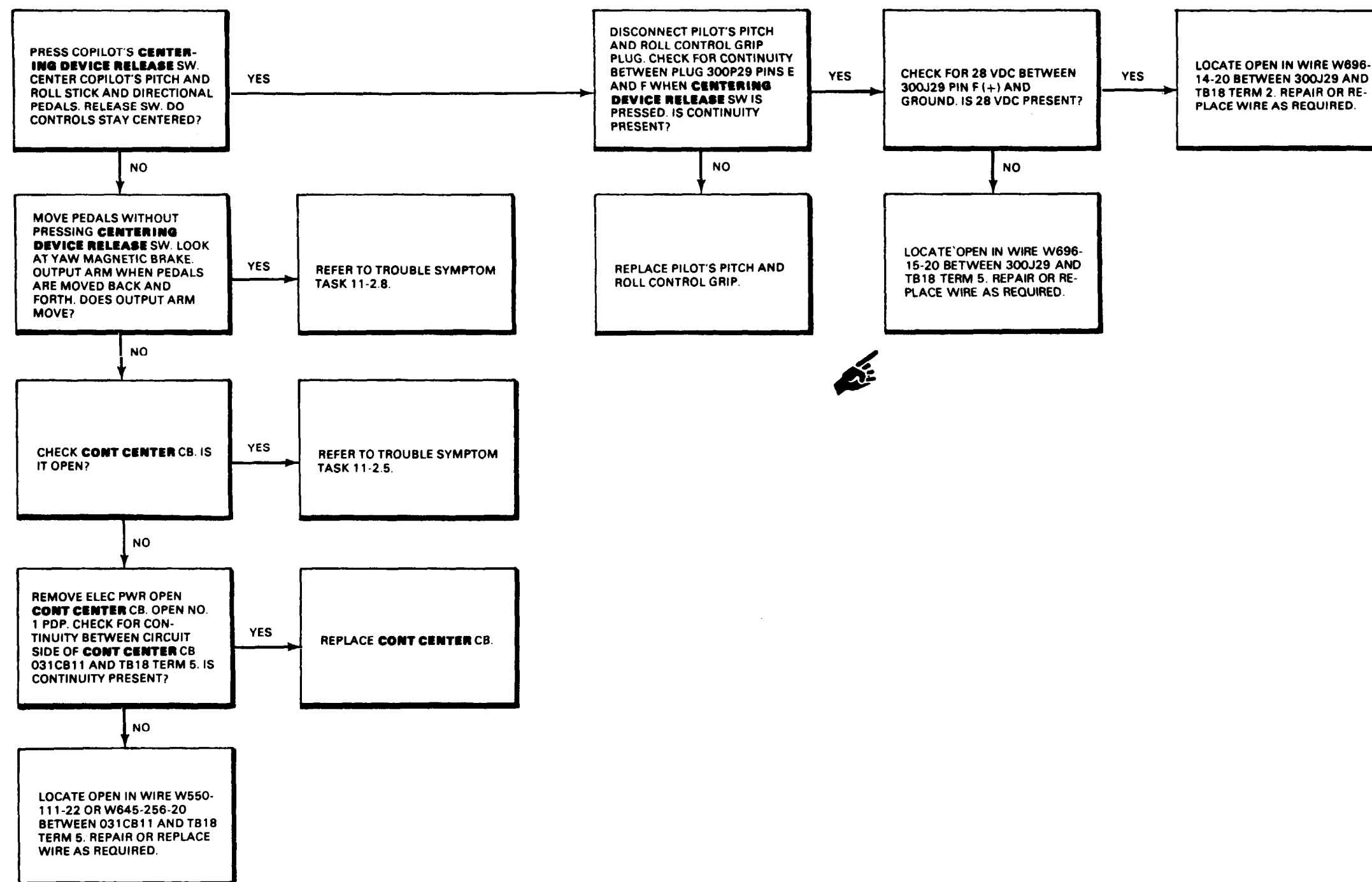

END OF TASK

11-2.7 CONTROL STICK DOES NOT REMAIN AT SELECTED POSITION

FAULT ISOLATION PROCEDURE

INITIAL SETUP

Application Configurations:
All

Tools:
Electrical Repairer's Tool Kit,
NSN 5180-00-323-4915
Multimeter

Materials:
None

Personnel Required:
67U10 Medium Helicopter Repairer
68F20 Aircraft Electrician

References:
TM 55-1520-240-23

Equipment Condition:
TM 55-1520-240-23
Battery Connected
Electrical Power On
Hydraulic Power On

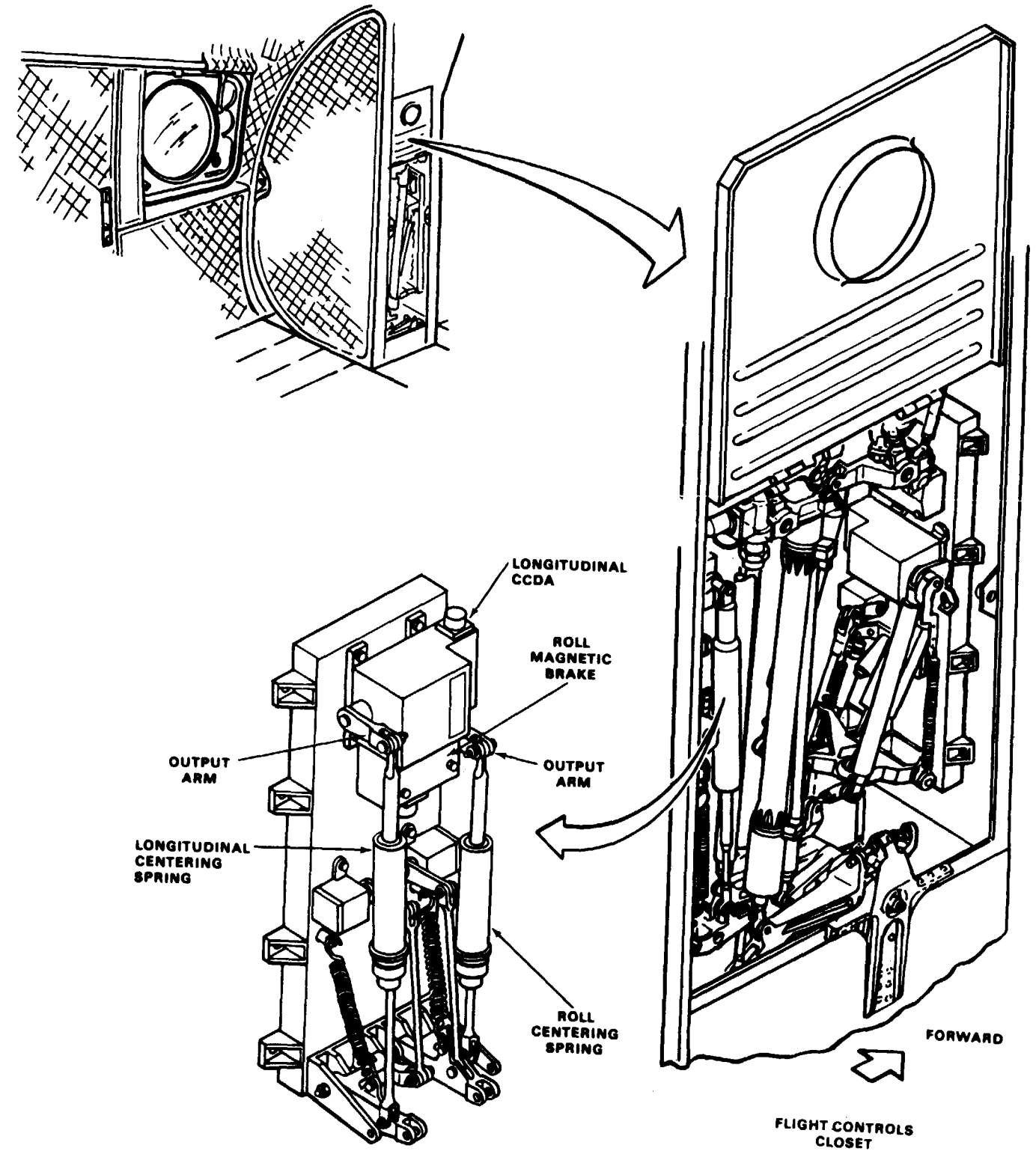
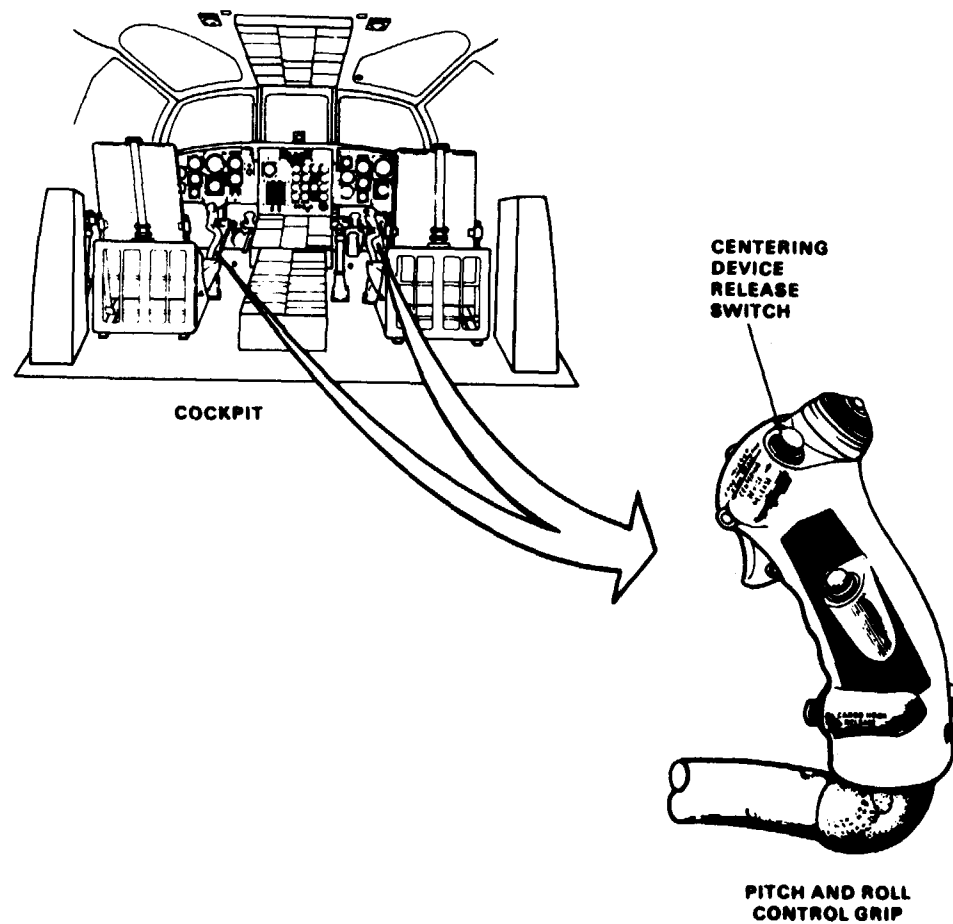

D145-4218-SPA

GO TO NEXT PAGE

68X54

11-2.7 CONTROL STICK DOES NOT REMAIN AT SELECTED POSITION (Continued)

11-2.7

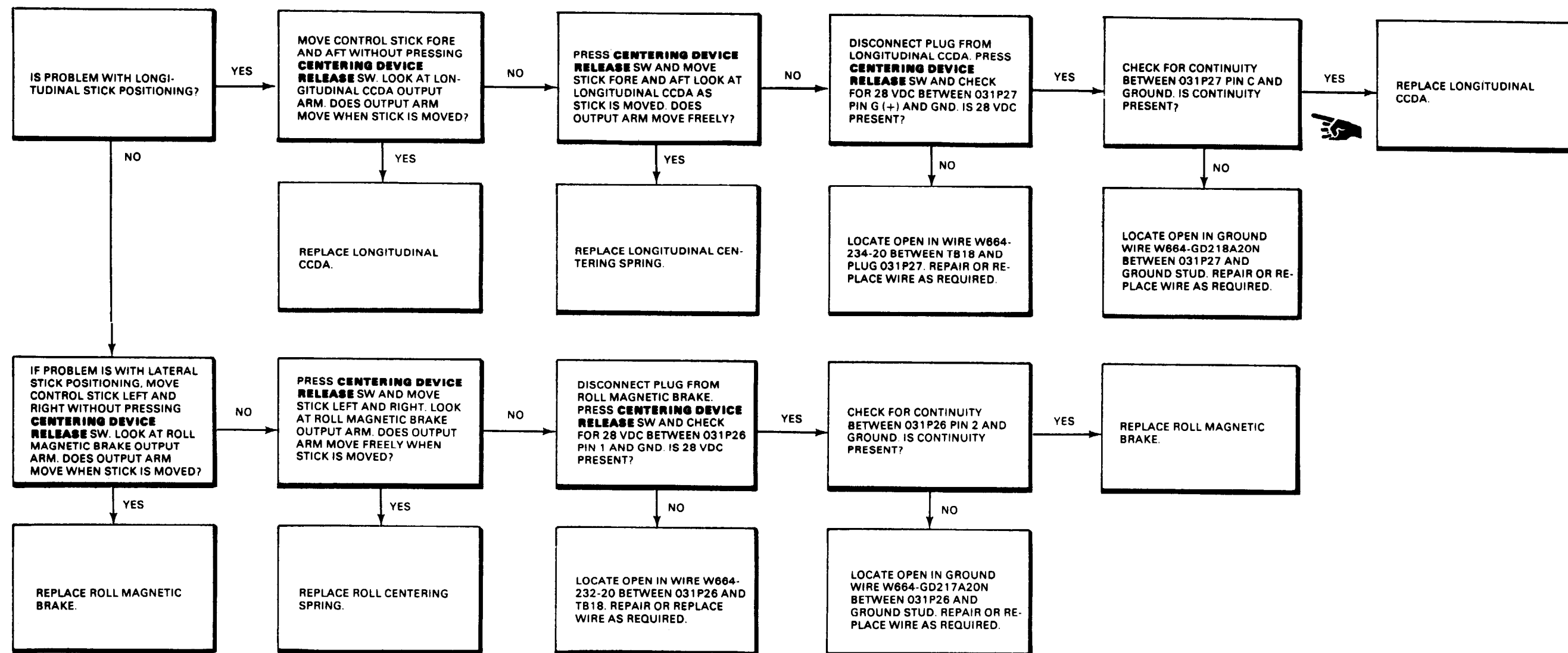

END OF TASK

FAULT ISOLATION PROCEDURE

INITIAL SETUP

Applicable Configurations:

All

Tools:

Electrical Repairer's Tool Kit,
NSN 5180-00-323-4915
Multimeter

Materials:

None

Personnel Required

67U10 Medium Helicopter Repairer
68F20 Aircraft Electrician

References:

TM 55-1520-240-23

Equipment Condition:

TM 55-1520-240-23
Battery Connected
Electrical Power On
Hydraulic Power On

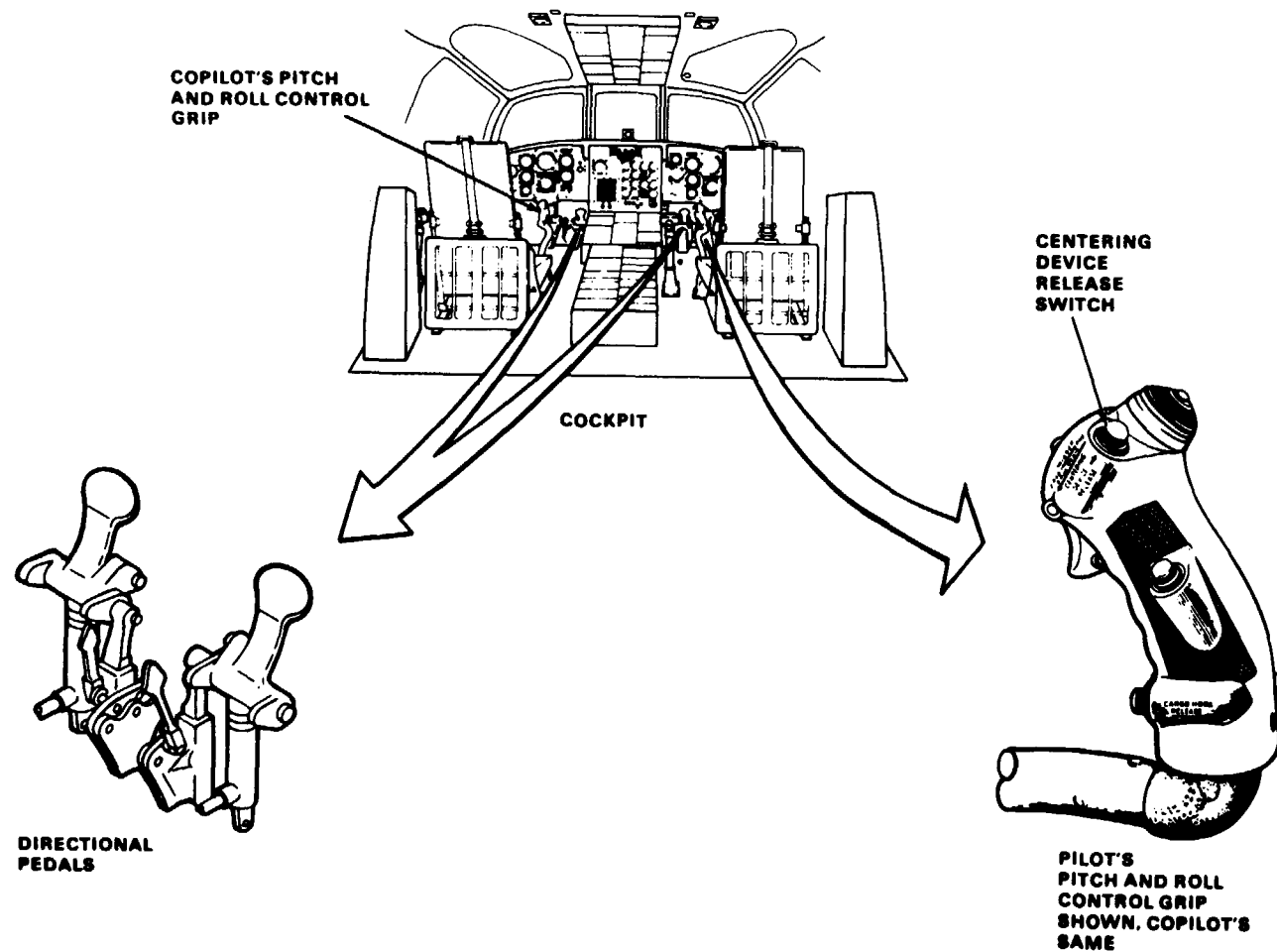

90X54

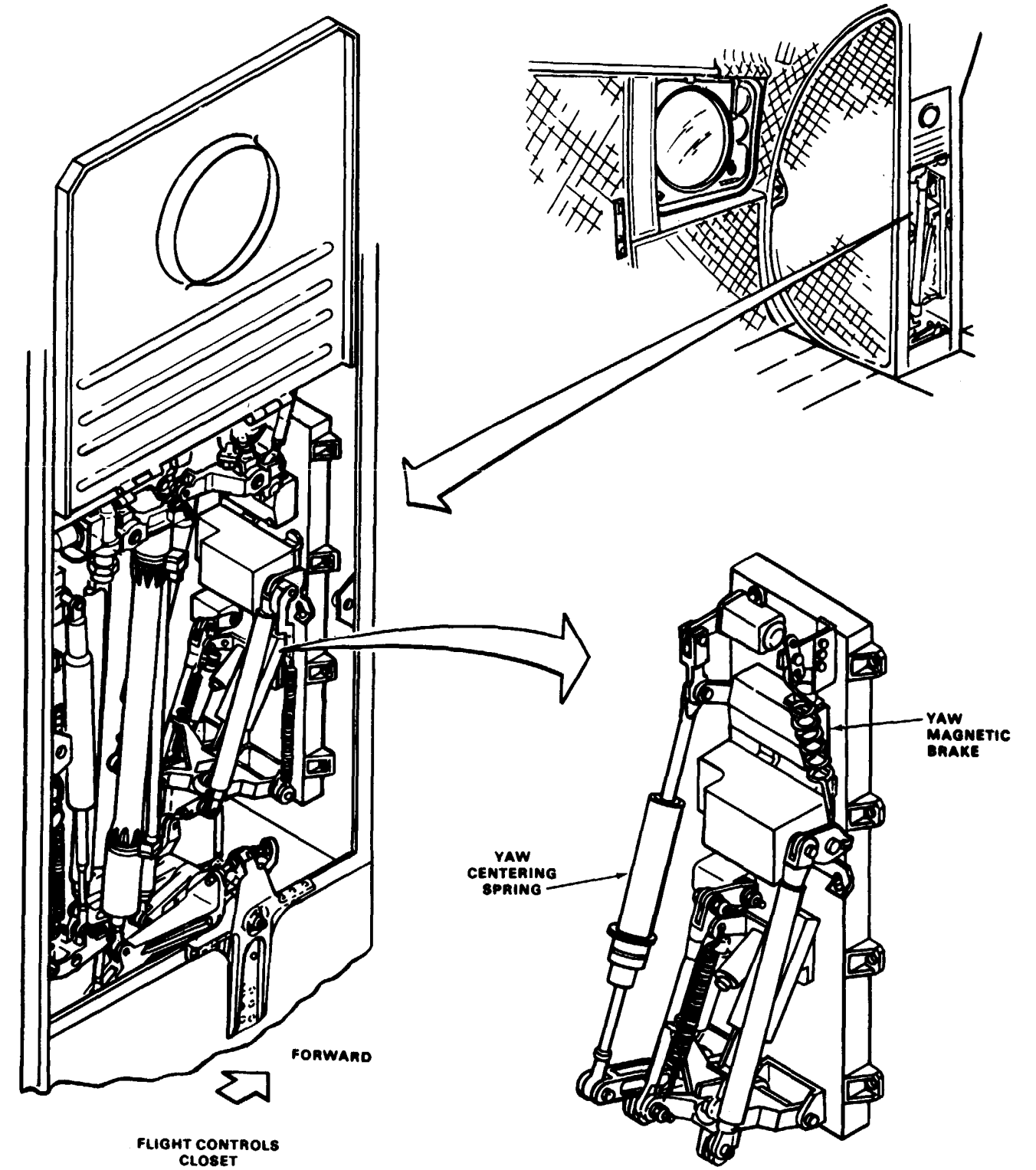

D145 - 4219 - SPA

GO TO NEXT PAGE

11-2.8 PEDALS DO NOT REMAIN AT SELECTED POSITION
(Continued)

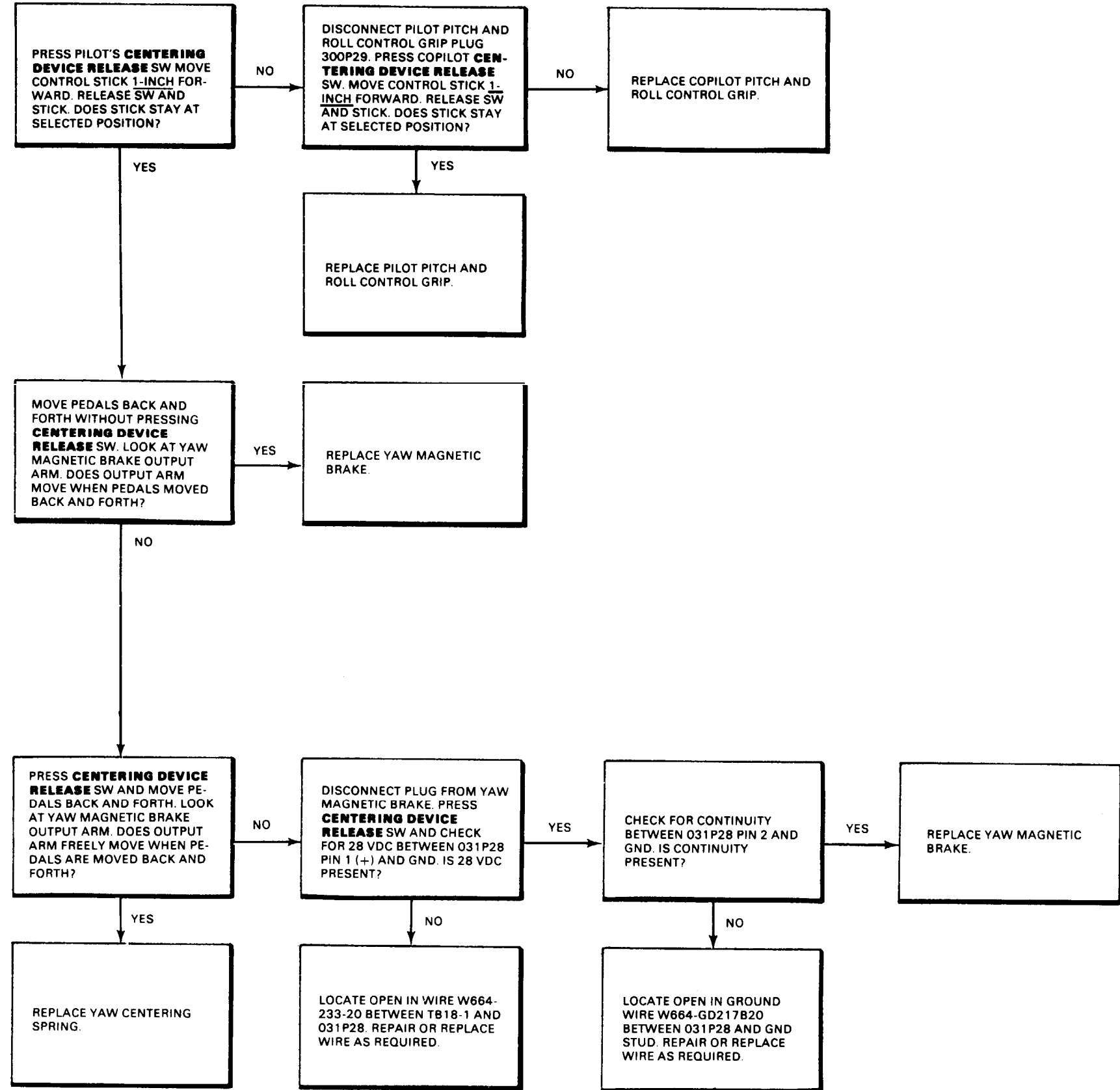

END OF TASK

11-2.9 PILOT'S THRUST CONTROL DOES NOT EASILY MOVE OR DOES NOT REMAIN AT SELECTED POSITION

FAULT ISOLATION PROCEDURE

INITIAL SETUP

Applicable Configurations:
All

Personnel Required:
67U10 Medium Helicopter Repairer
68F20 Aircraft Electrician

Tools:
Electrical Repairer's Tool Kit,
NSN 5180-00-323-4915
Aircraft Mechanic's Tool Kit,
NSN 5180-00-323-4692
Multimeter

References:
TM 55-1520-240-23

Equipment Condition:
TM 55-1520-240-23:
Battery Connected
Electrical Power On
Hydraulic Power On

Materials:
None

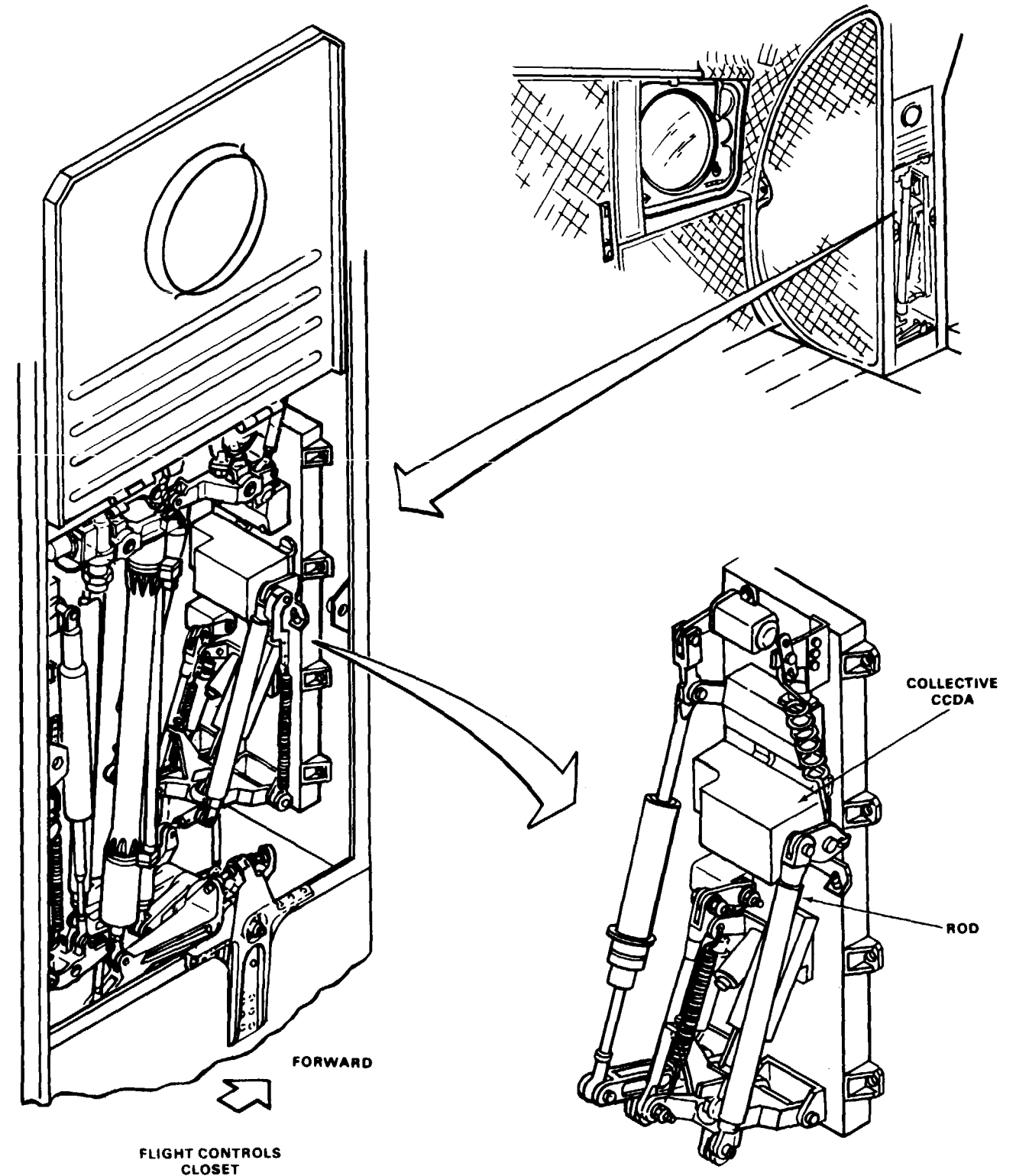
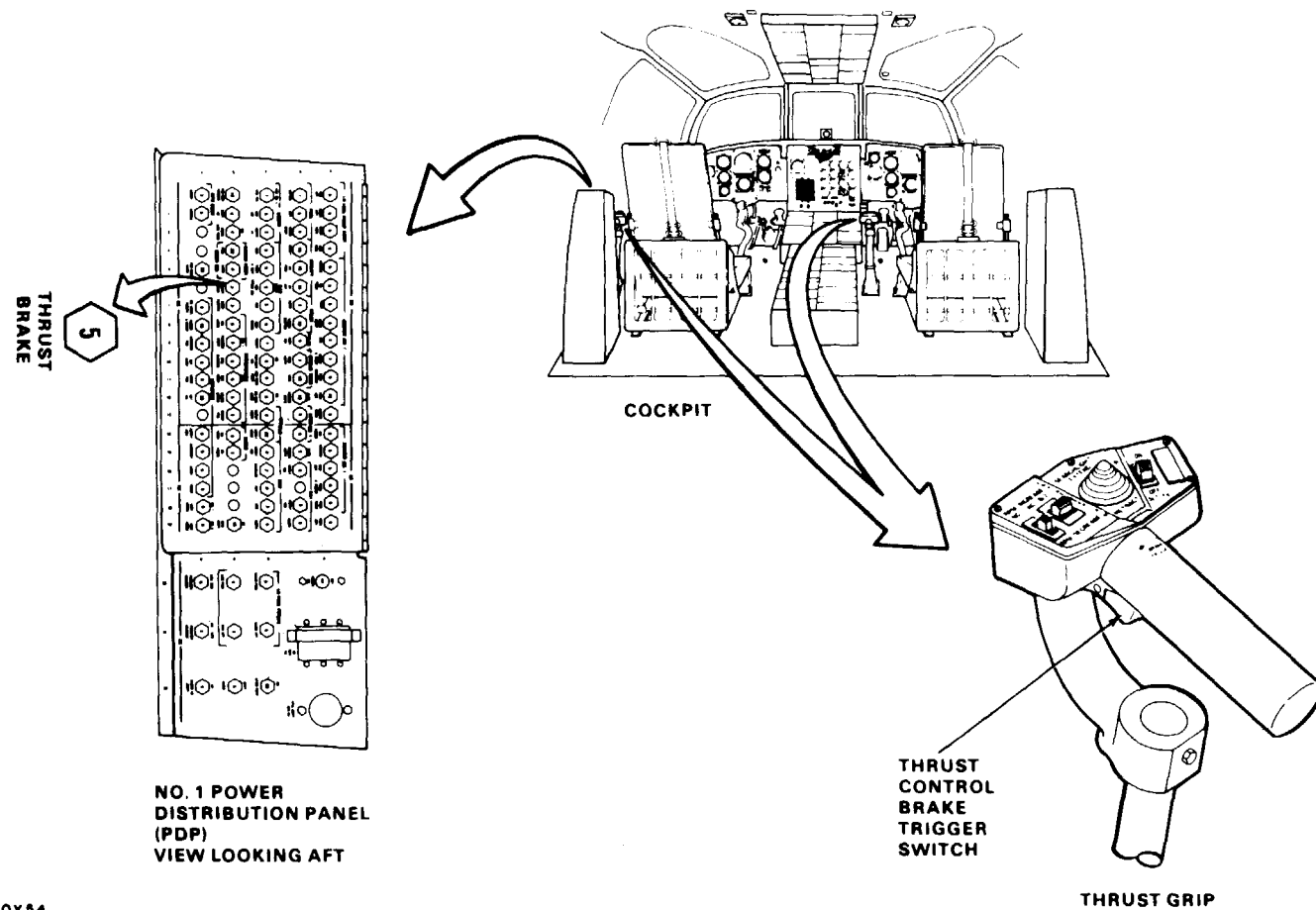

11-2.9 PILOT'S THRUST CONTROL DOES NOT EASILY MOVE OR DOES NOT REMAIN AT SELECTED POSITION (Continued)

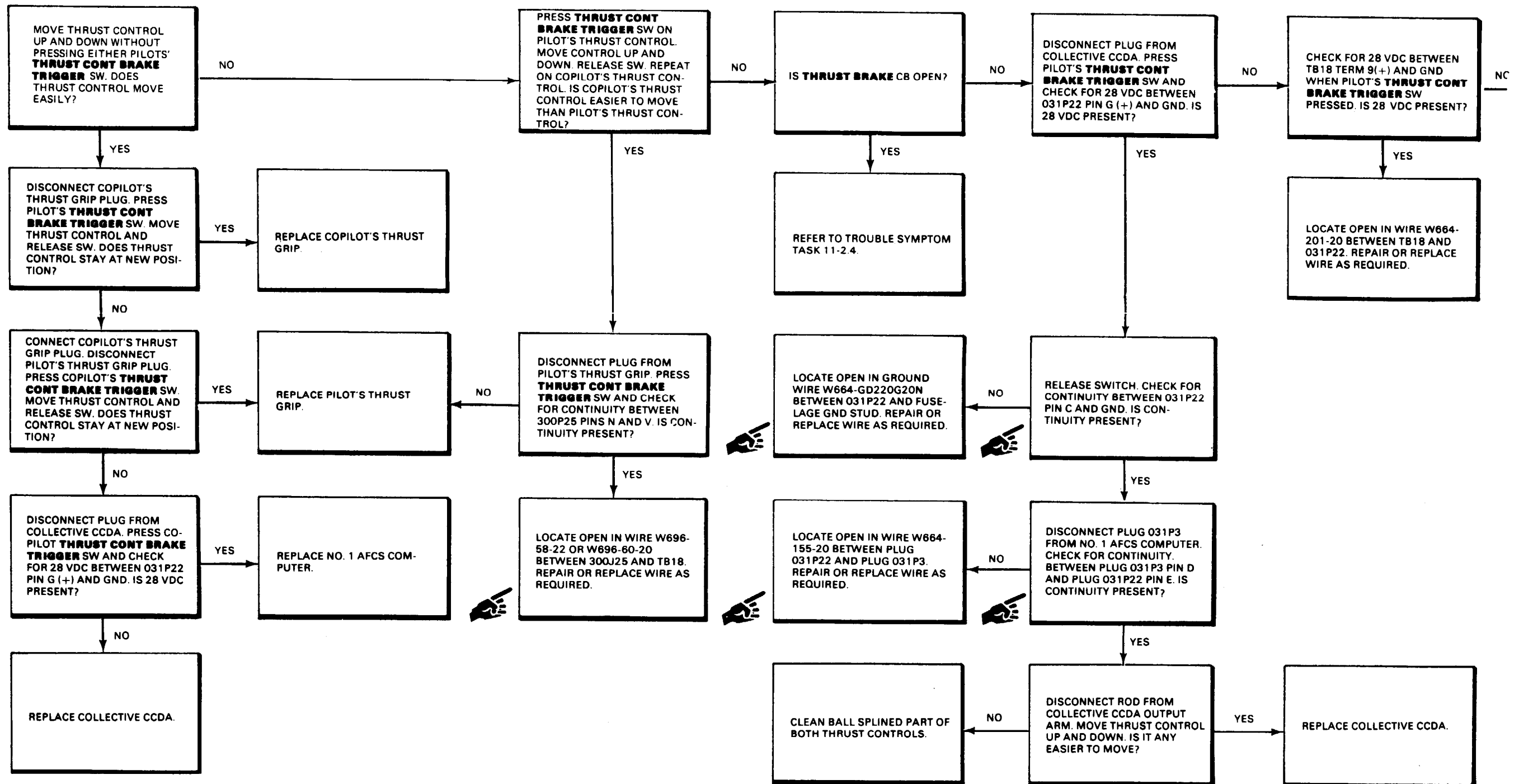

GO TO NEXT PAGE

11-2.9 PILOT'S THRUST CONTROL DOES NOT EASILY MOVE OR DOES NOT REMAIN AT SELECTED POSITION (Continued)

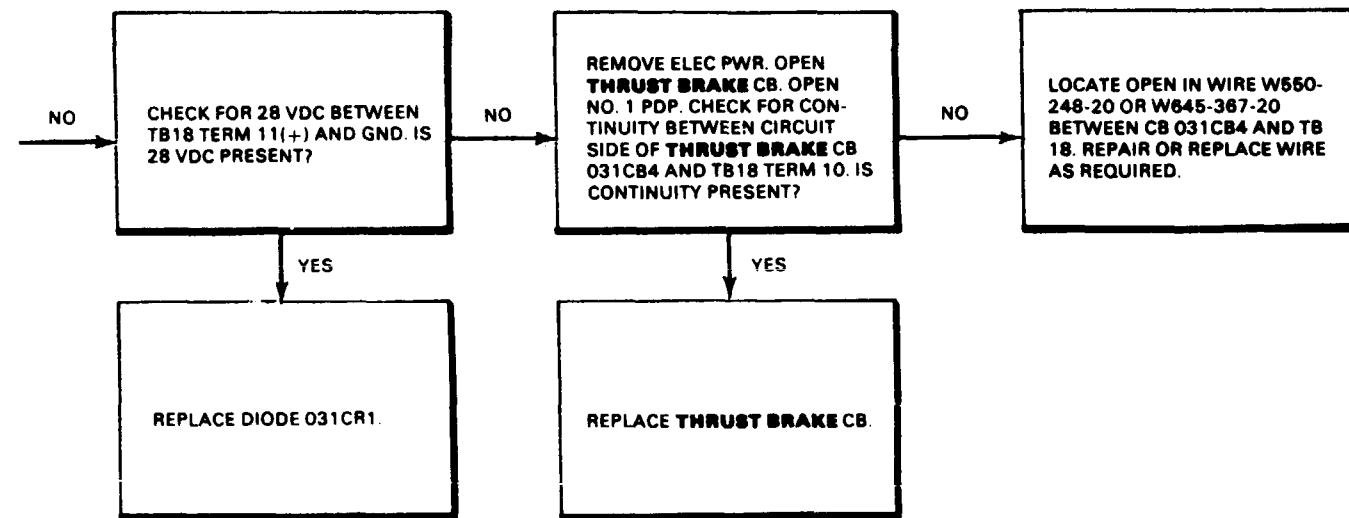

GO TO NEXT PAGE

11-2.9 PILOT'S THRUST CONTROL DOES NOT EASILY MOVE OR DOES NOT REMAIN AT SELECTED POSITION (Continued)

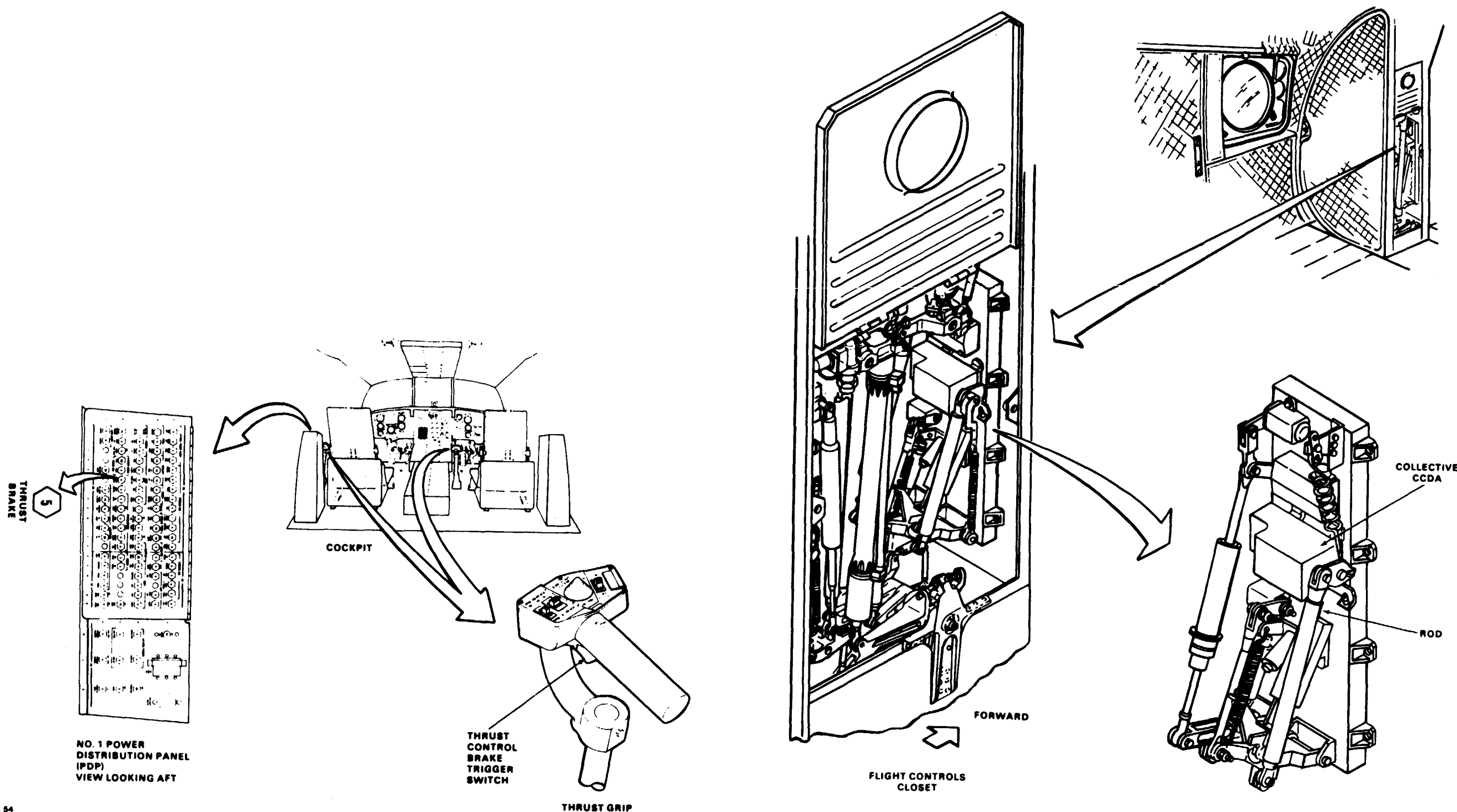

D145-11820-SPA

END OF TASK

11-2.10 COPILOT'S THRUST CONTROL DOES NOT EASILY MOVE OR DOES NOT REMAIN AT SELECTED POSITION

FAULT ISOLATION PROCEDURE

INITIAL SETUP

Applicable Configurations:
All

Personnel Required:
Aircraft Electrician (2)

Tools:
Electrical Repairer's Tool Kit,
NSN 5180-00-323-4915
Multimeter

References:
TM 55-1520-240-23

Materials:
None

Equipment Condition:
TM 55-1520-240-23:
Battery Connected
Electrical Power On
Hydraulic Power On

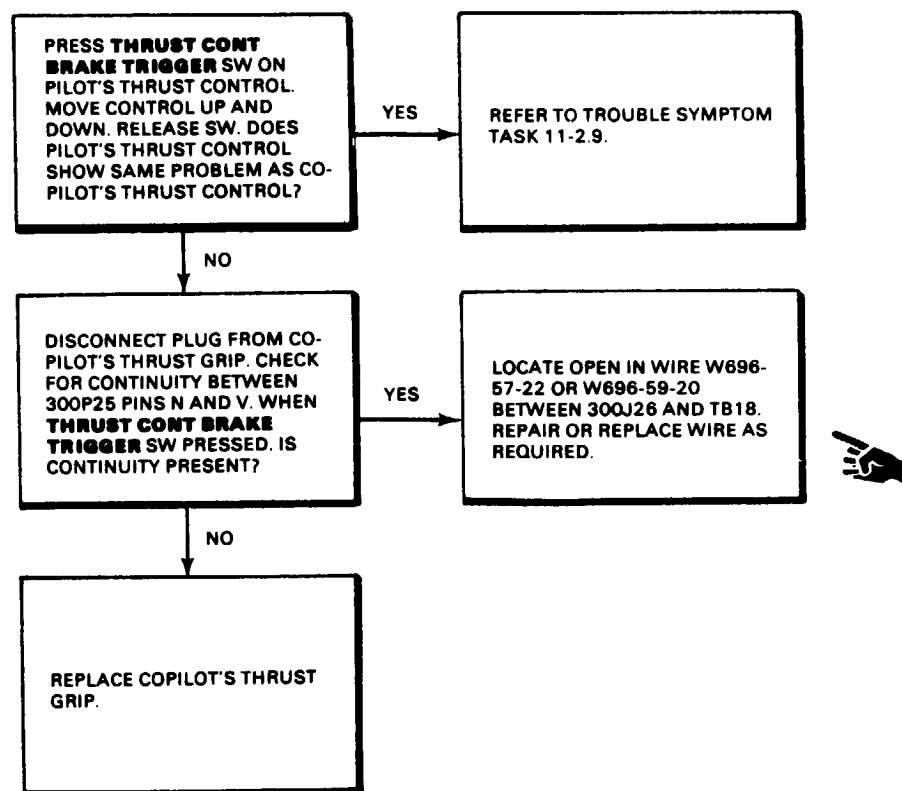
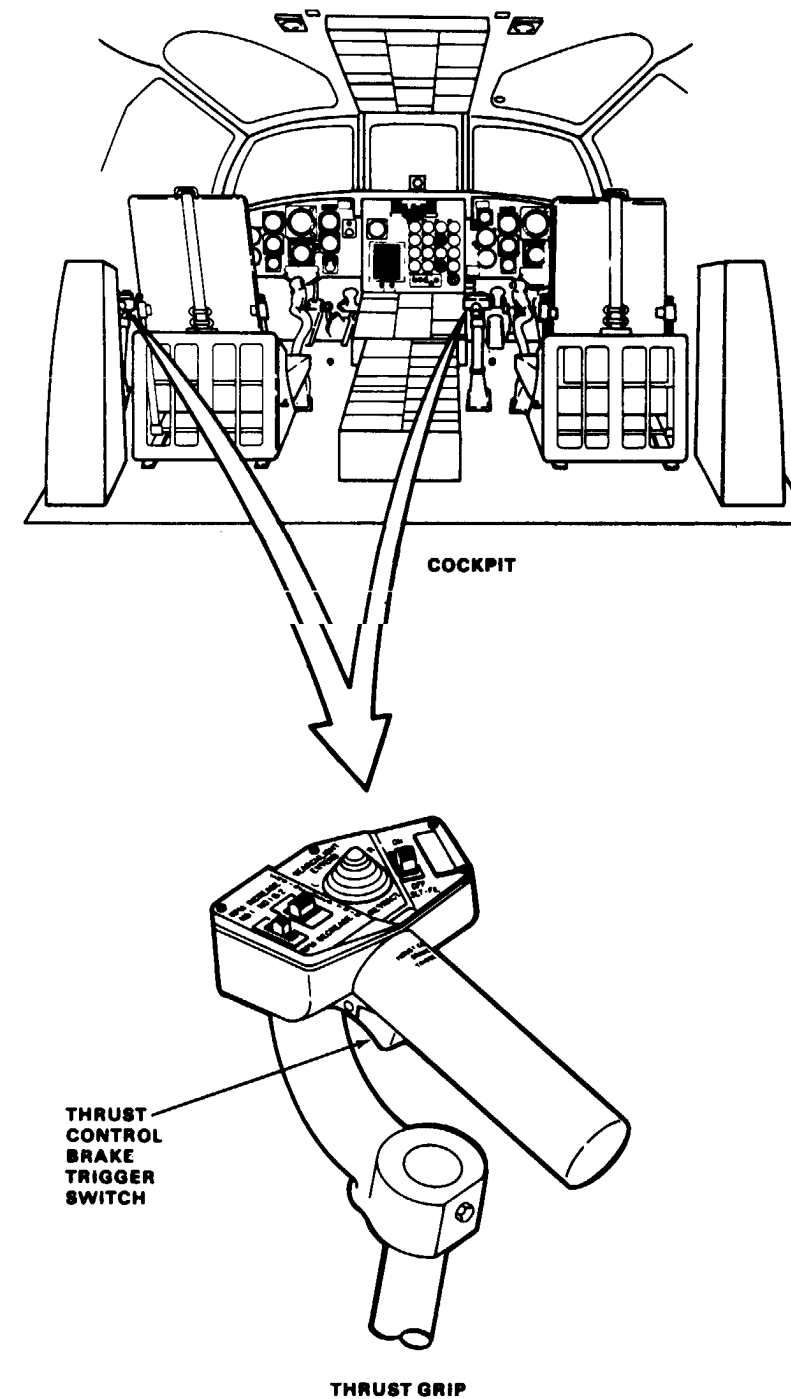

11-2.11 CONTROL STICK WILL NOT REMAIN AT SELECTED POSITION AFTER COPILOT'S CENTERING DEVICE RELEASE SWITCH RELEASED

FAULT ISOLATION PROCEDURE

INITIAL SETUP

Applicable Configurations:
All

Tools:
Electrical Repairer's Tool Kit,
NSN 5180-00-323-4915
Multimeter

Materials:
None

Personnel Required:
68F10 Aircraft Electrician
68F20 Aircraft Electrician

References:
TM 55-1520-240-23

Equipment Condition:
TM 55-1520-240-23:
Battery Connected
Electrical Power On
Hydraulic Power On

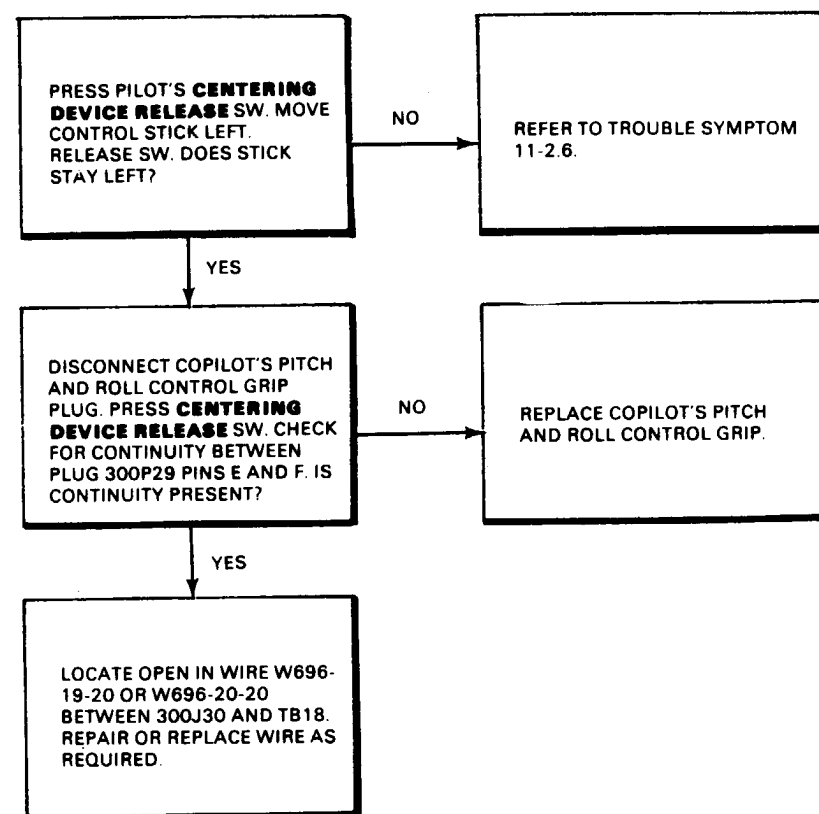
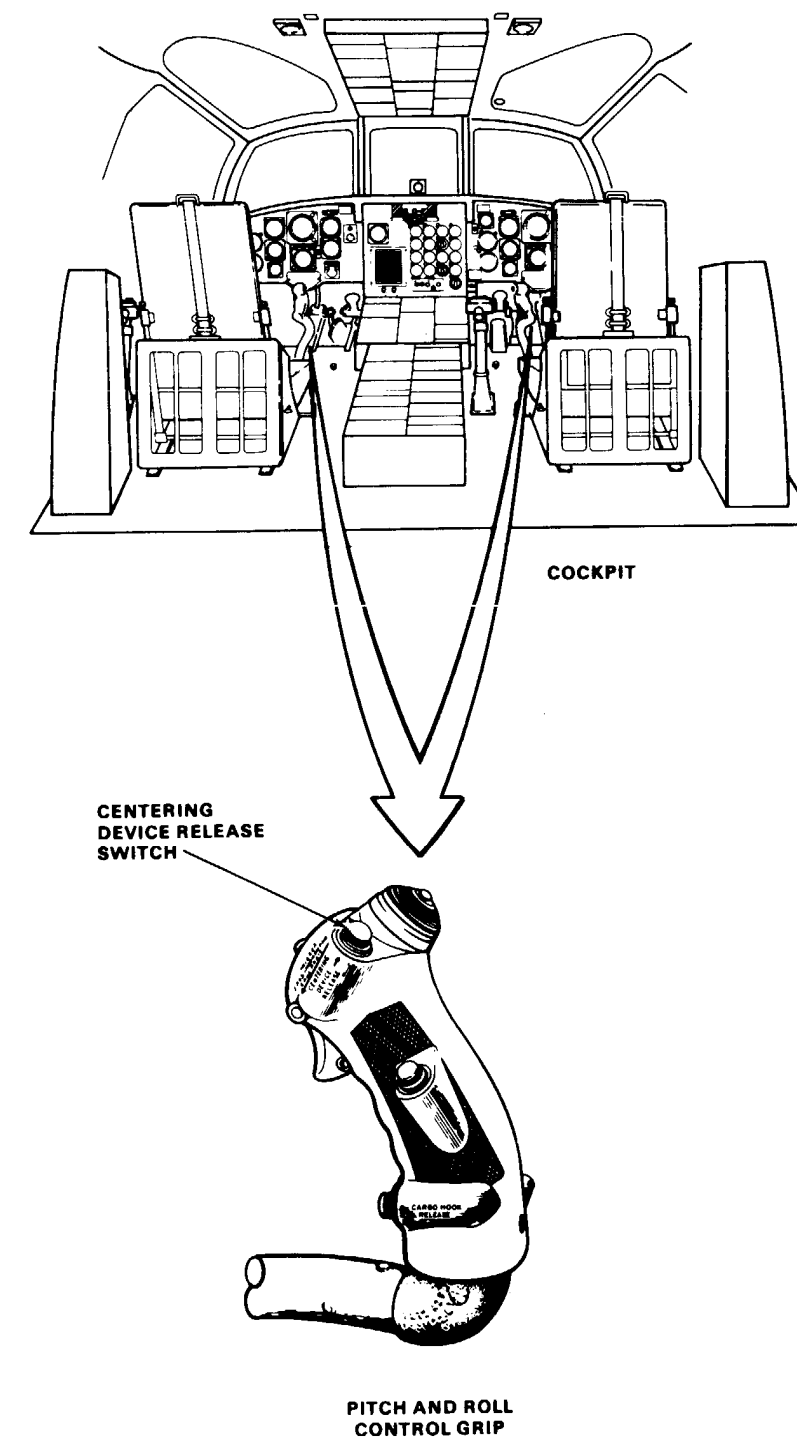

11-3 AFCS

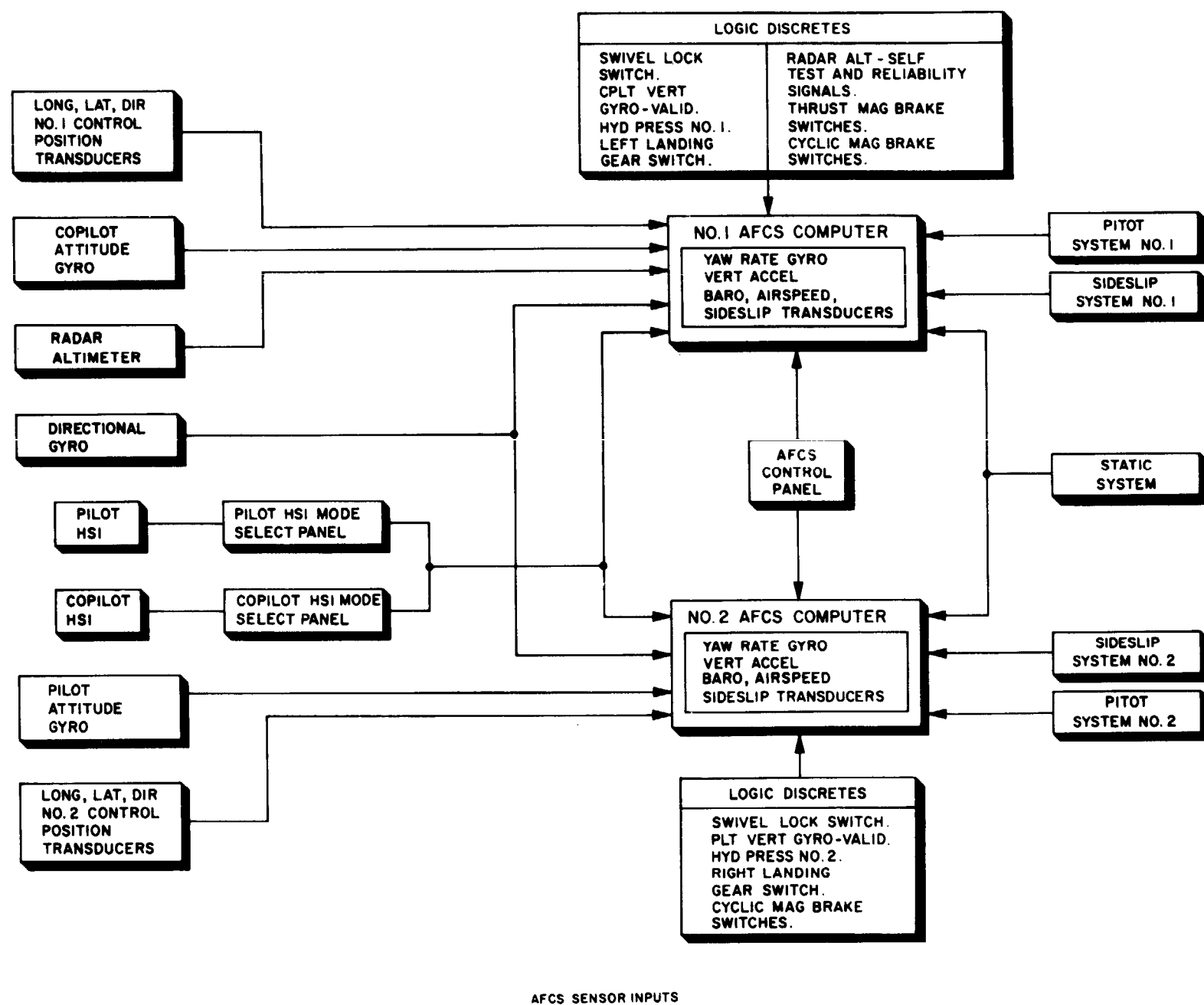

AFCS SENSOR INPUTS

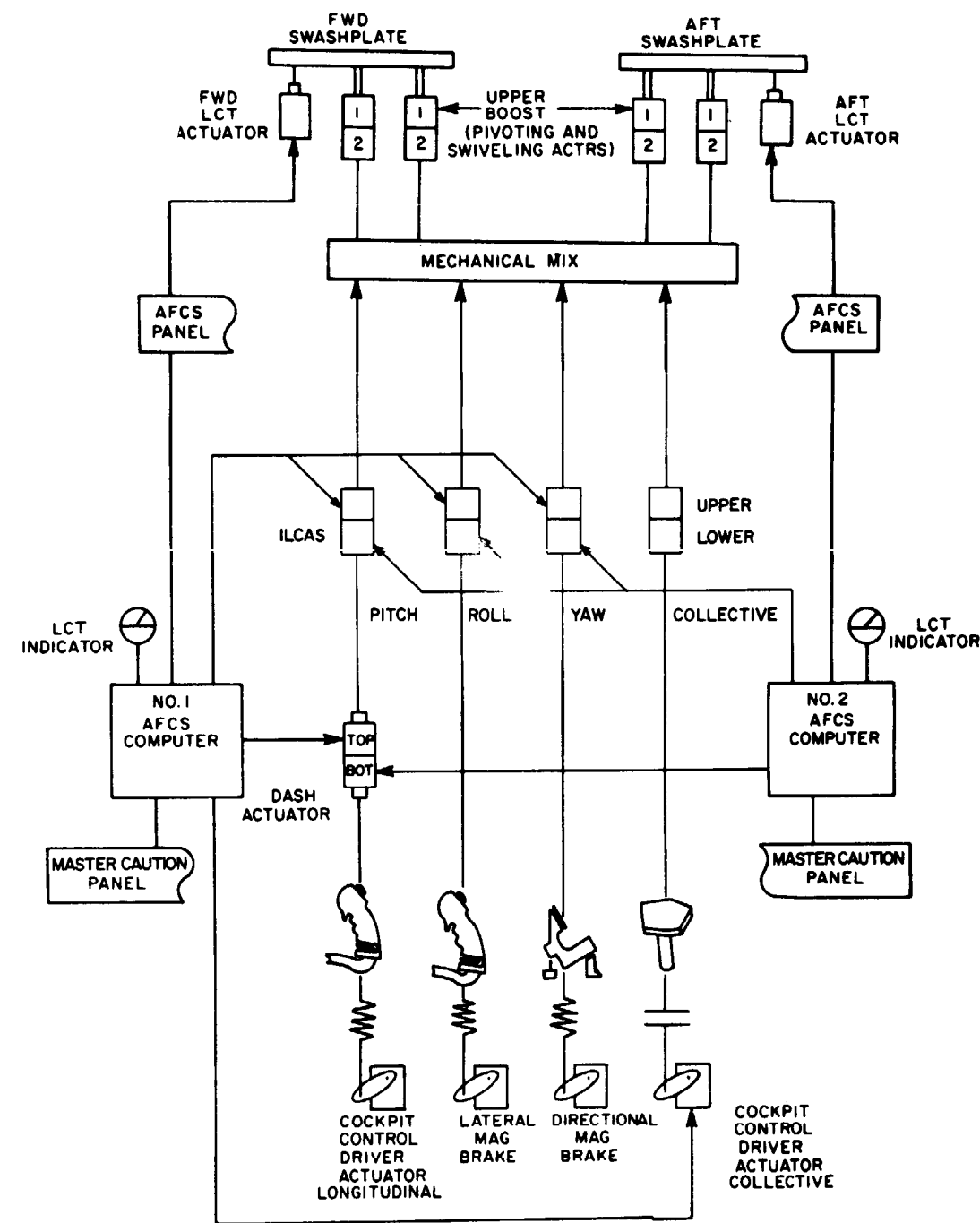

NO. 1 AND NO. 2 AFCS COMPONENT INTERFACES

11-3.1 AFCS SCHEMATIC (AFCS POWER AND CONTROL) (Continued)

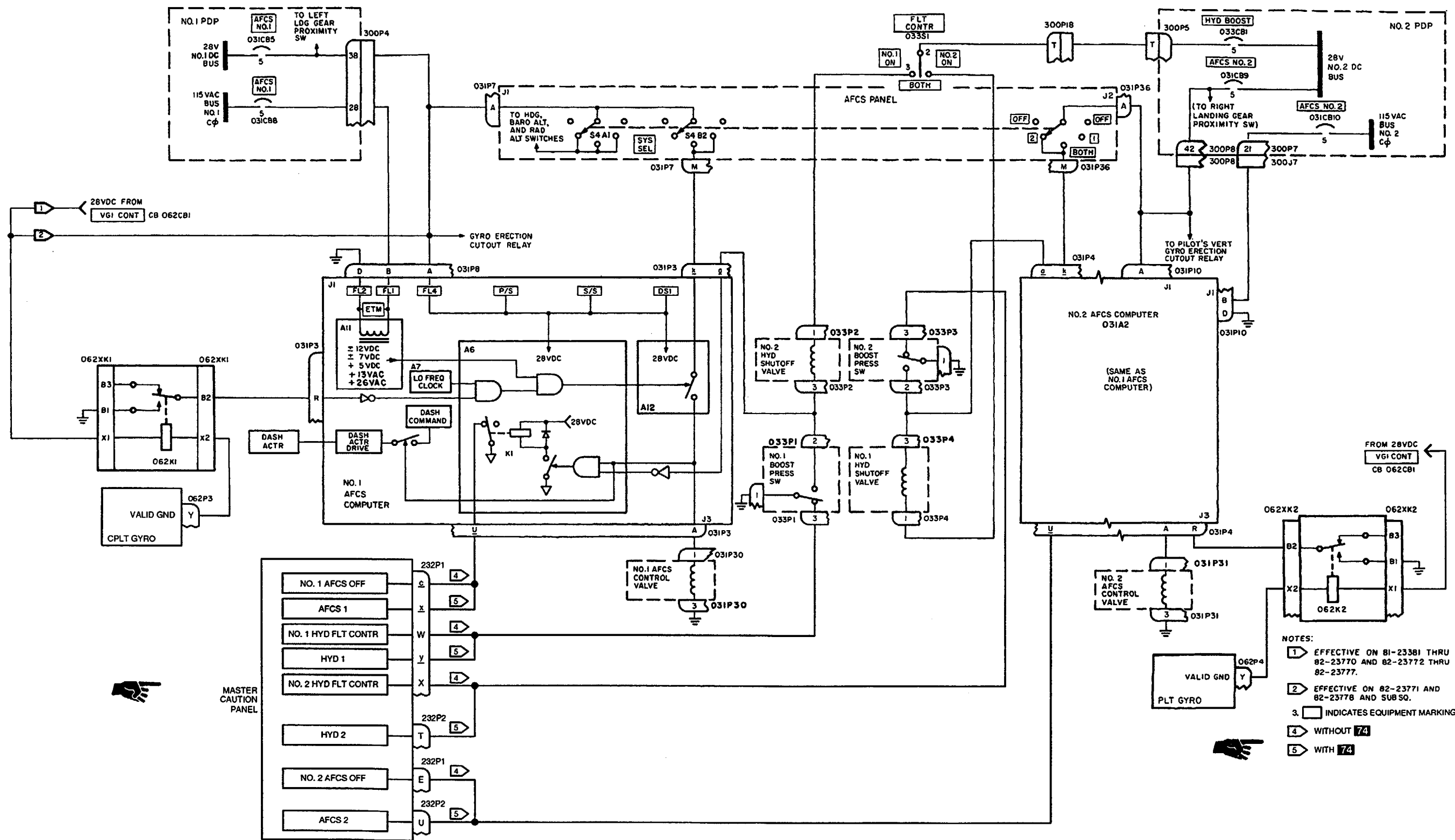

- NOTES:
- 1 EFFECTIVE ON 81-23381 THRU 82-23770 AND 82-23772 THRU 82-23777.
 - 2 EFFECTIVE ON 82-23771 AND 82-23778 AND SUB SQ.
 - 3. INDICATES EQUIPMENT MARKINGS.
 - 4 WITHOUT
 - 5 WITH

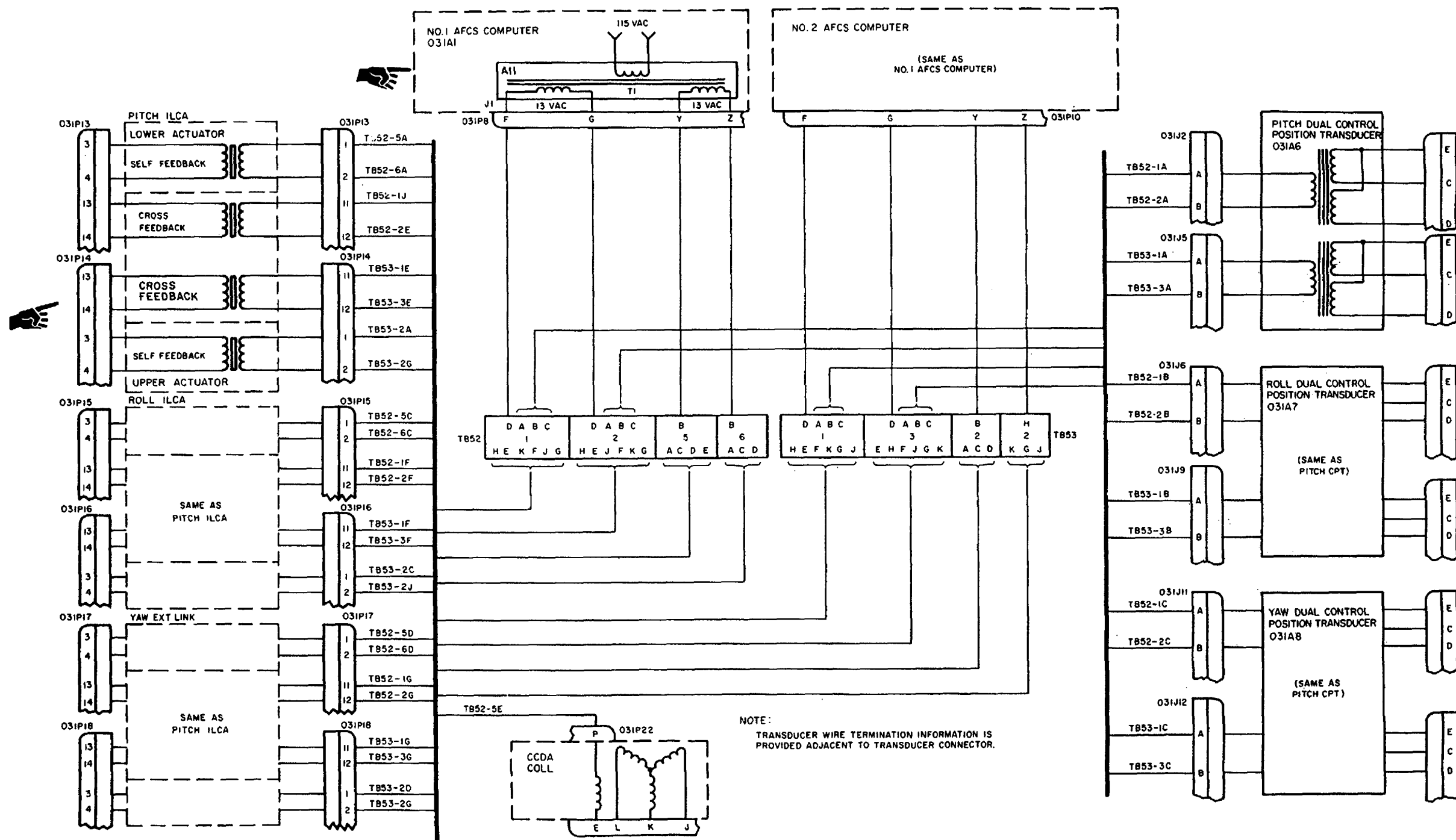

9596

11-3 AFCS

11-3

11-3.1 AFCS SCHEMATIC (COLLECTIVE CCDA POWER AND CONTROL)

11-3.1

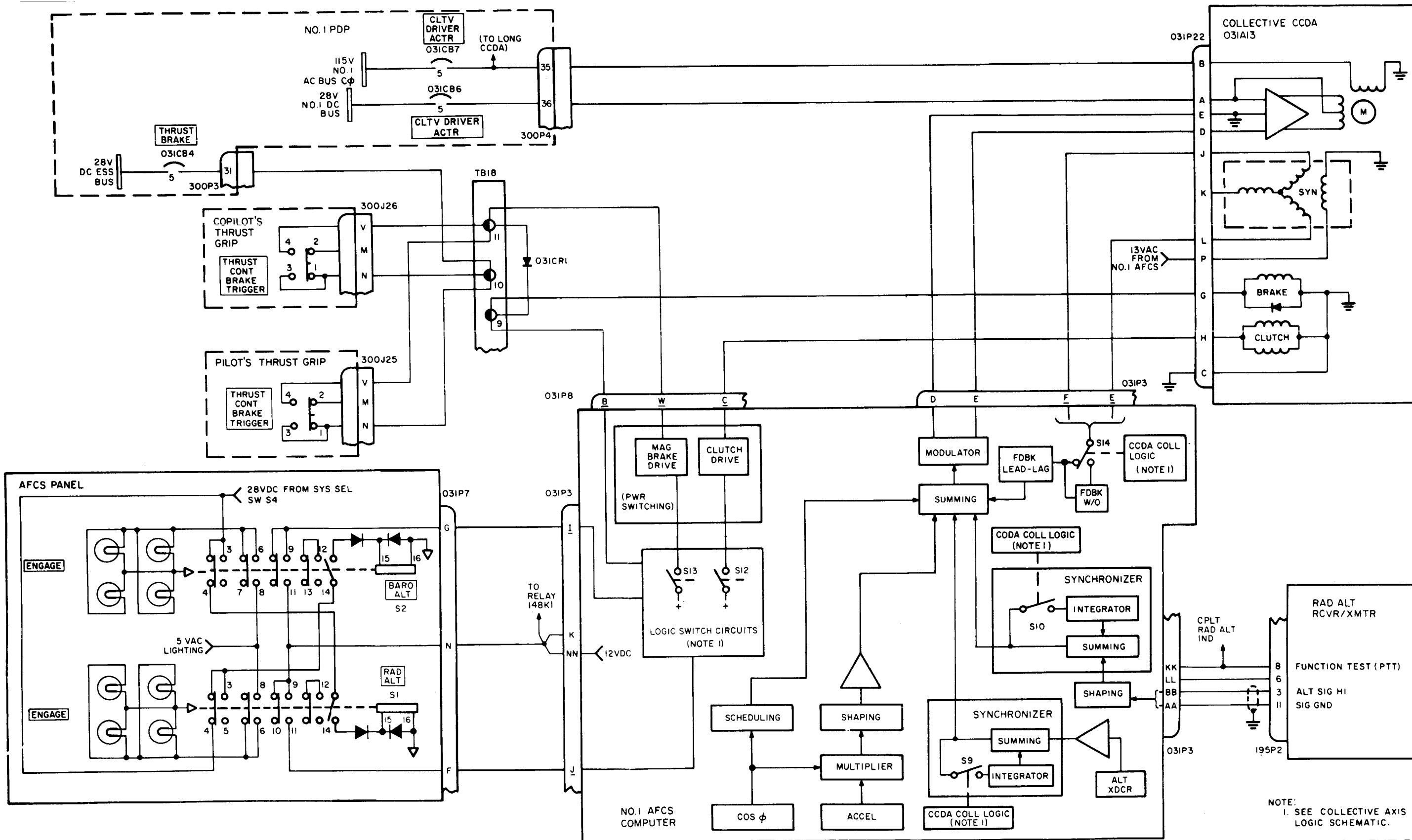

NOTE:
1. SEE COLLECTIVE AXIS LOGIC SCHEMATIC.

9597

GO TO NEXT PAGE
Change 3 11-39

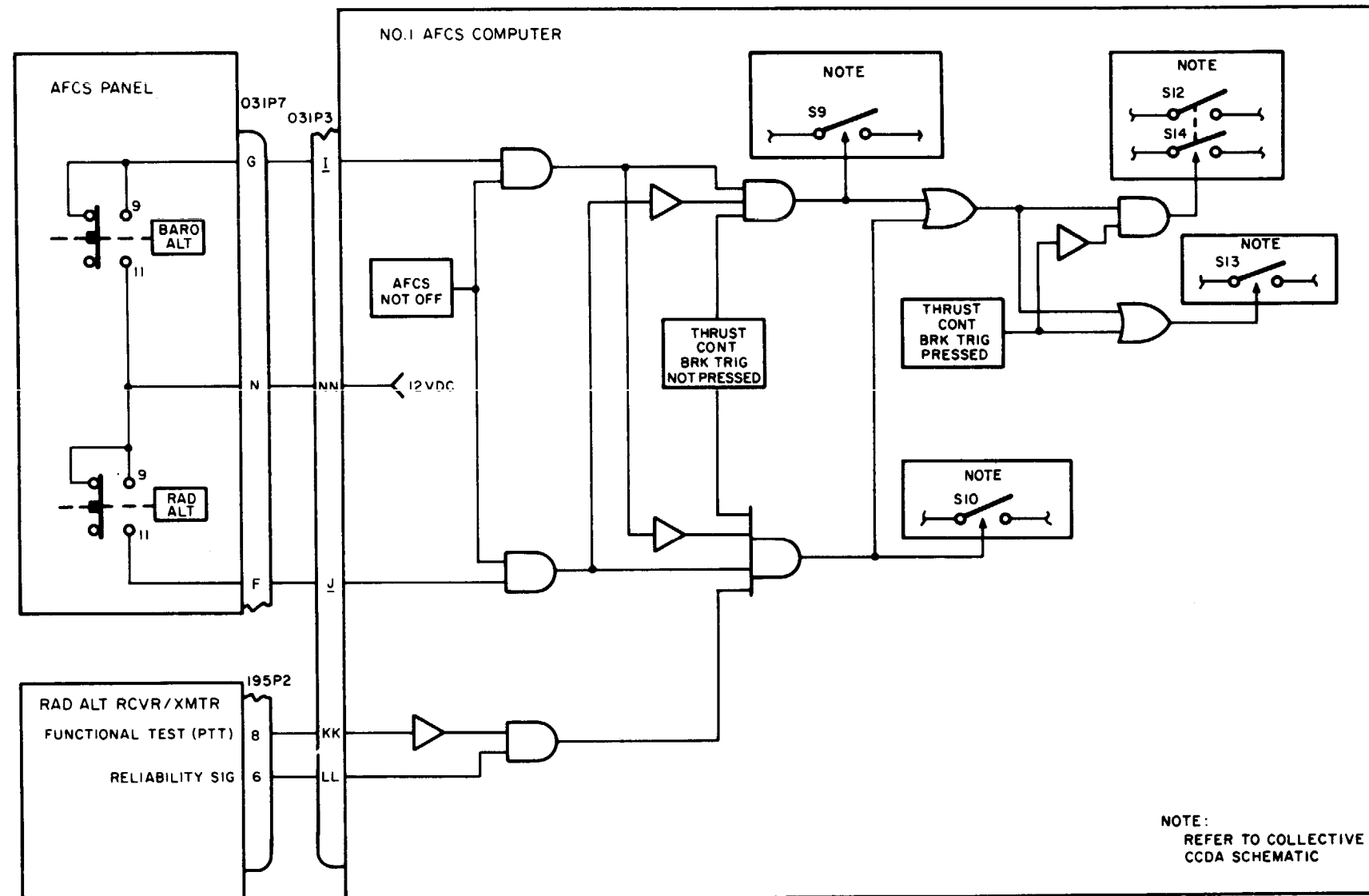

NOTE:
REFER TO COLLECTIVE
CCDA SCHEMATIC

9598

11-3.1 AFCS SCHEMATIC (LONGITUDINAL CCDA AND MAGNETIC BRAKES POWER AND CONTROL)

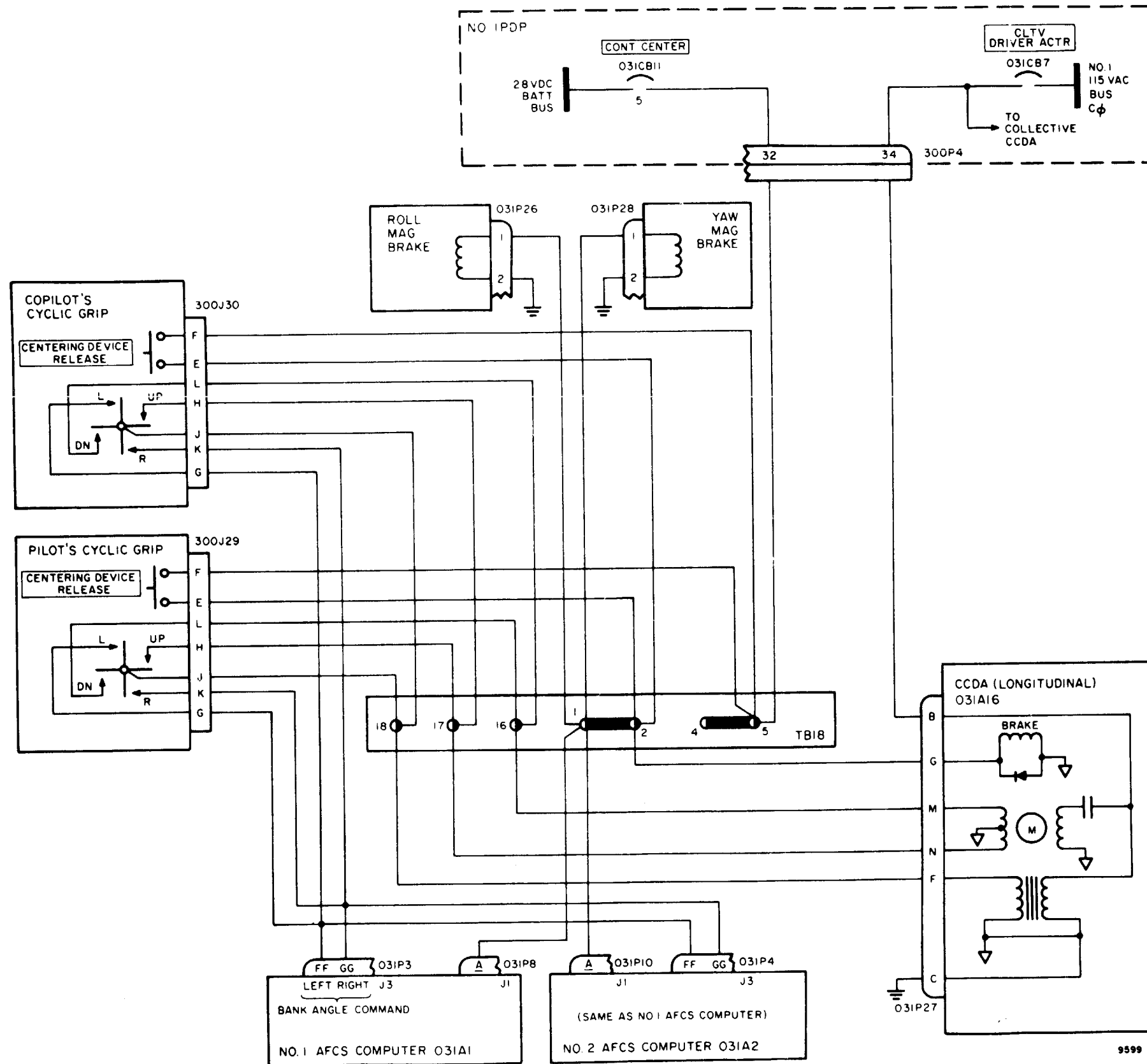

9599

GO TO NEXT PAGE
Change 3 11-41

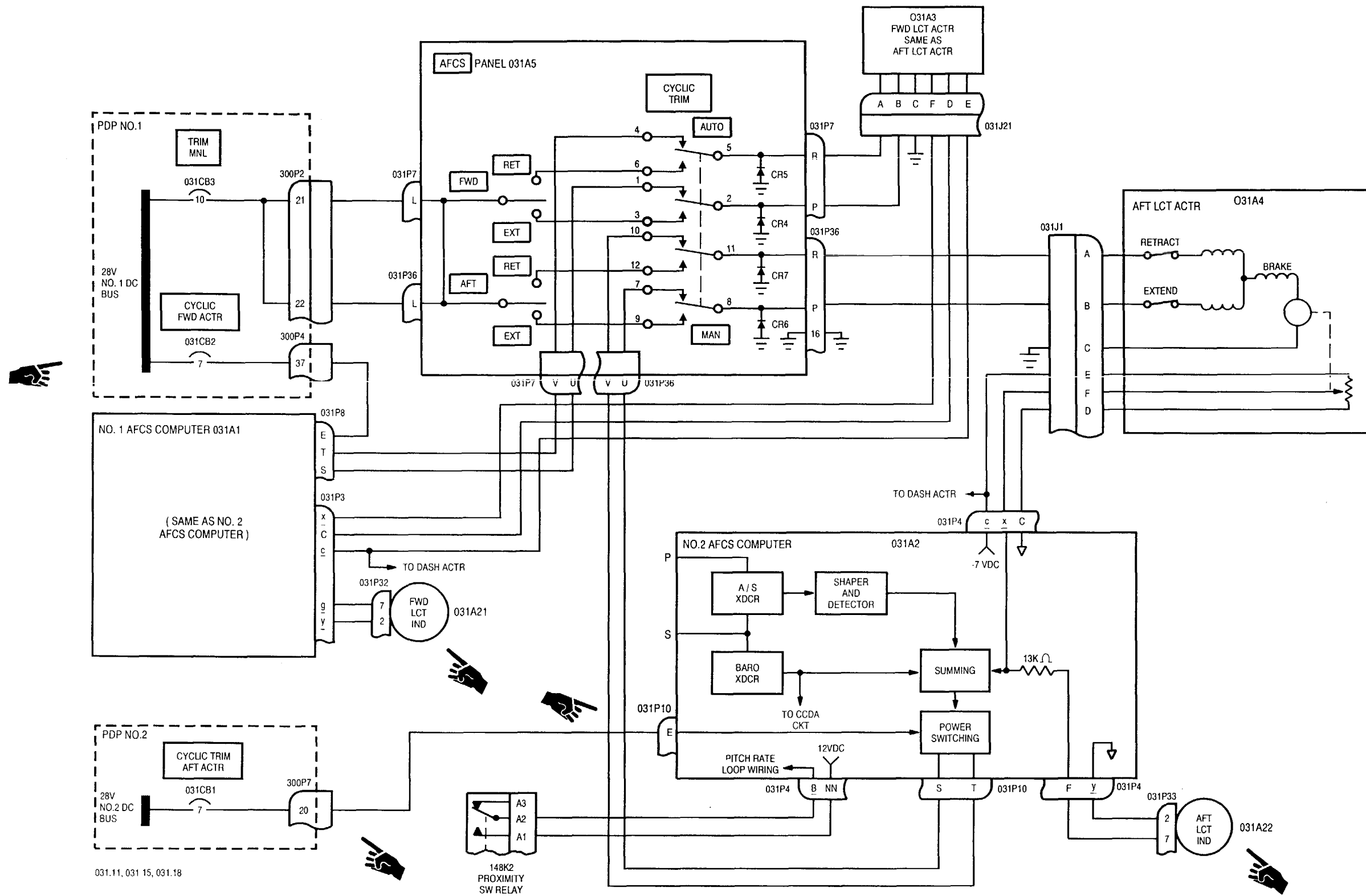

031.11, 031 15, 031.18

A9600

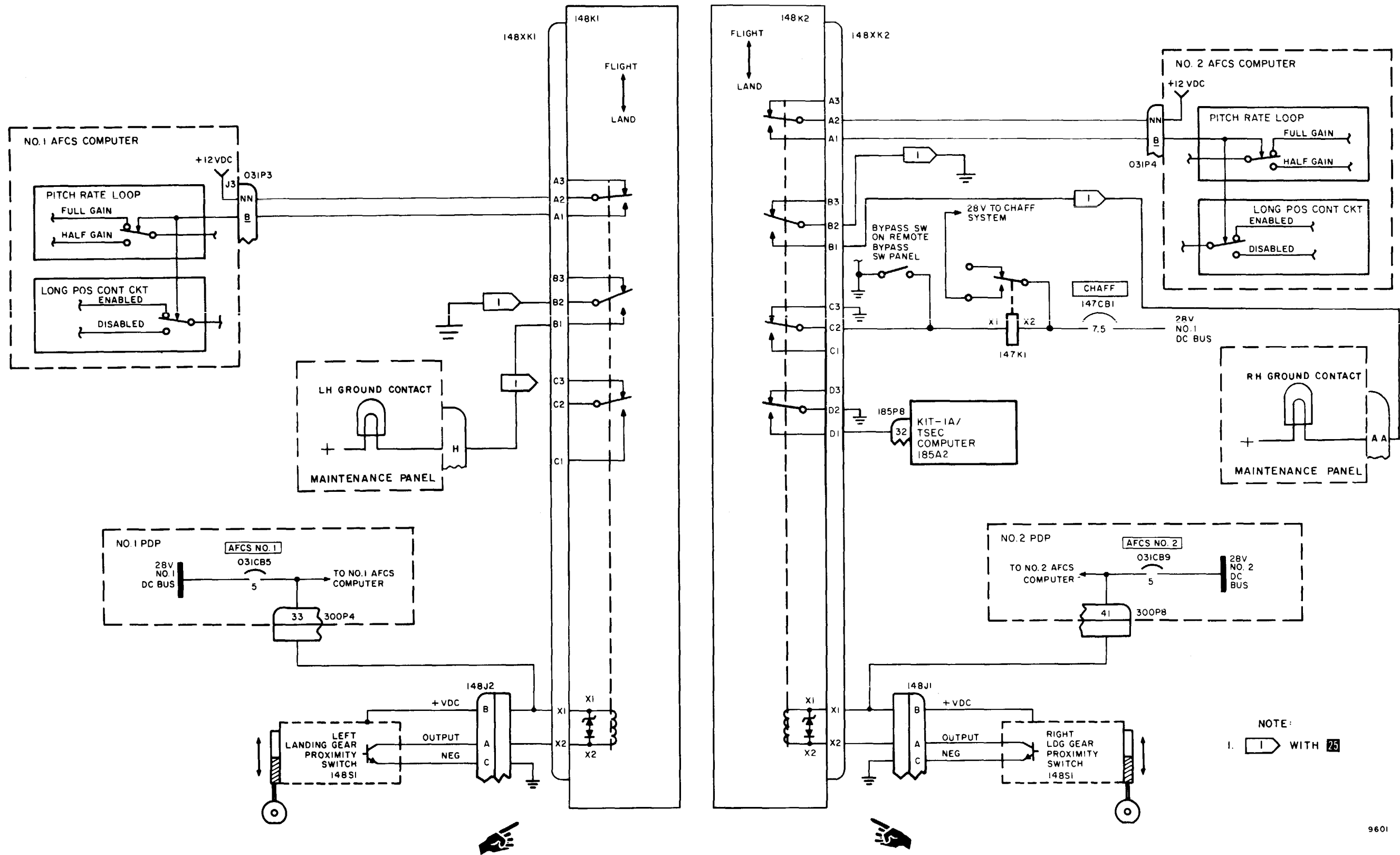

9601

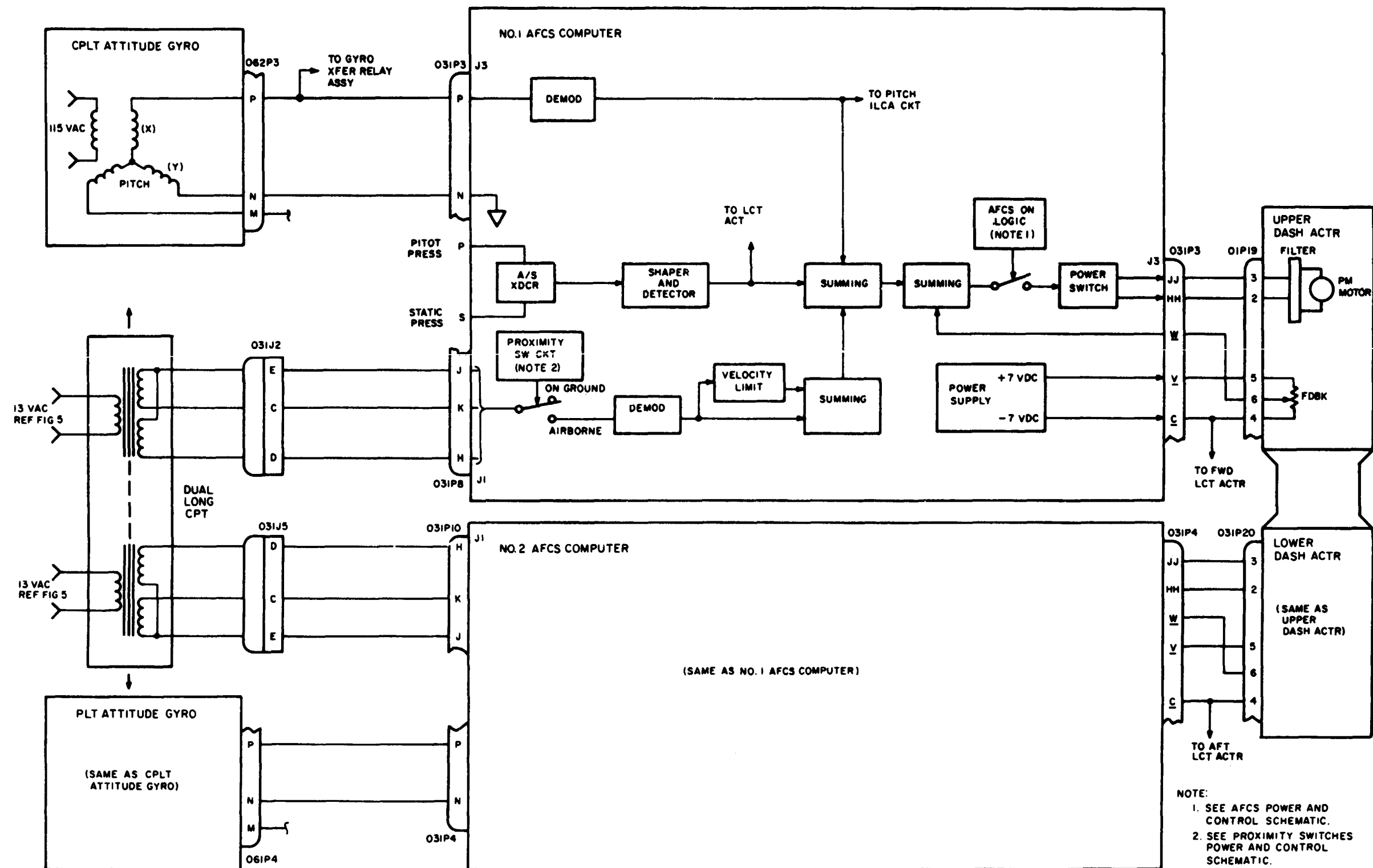

9602

11-3 AFCS

11-3.1 AFCS SCHEMATIC (PITCH ILCA SIGNAL CIRCUIT)

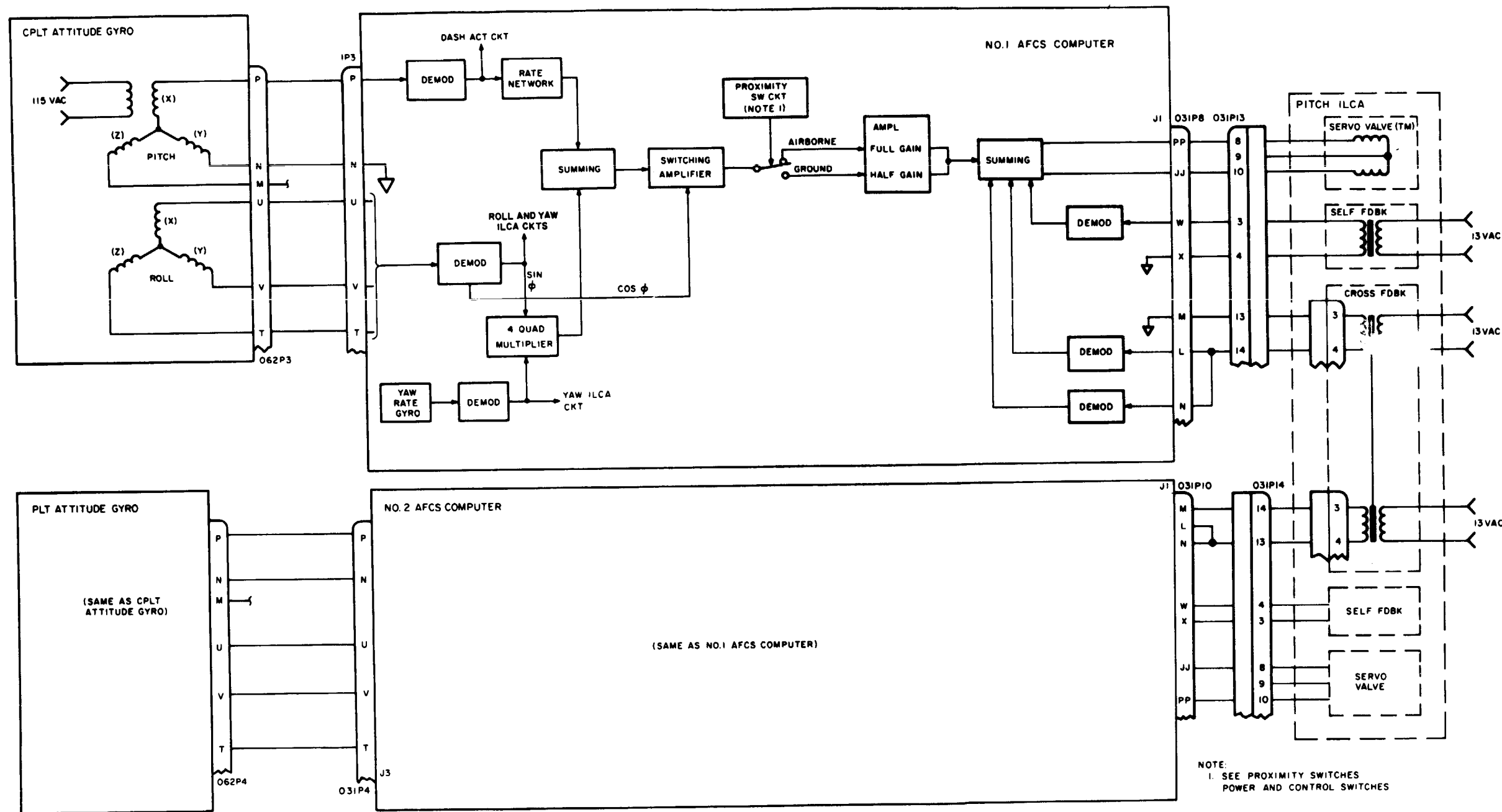

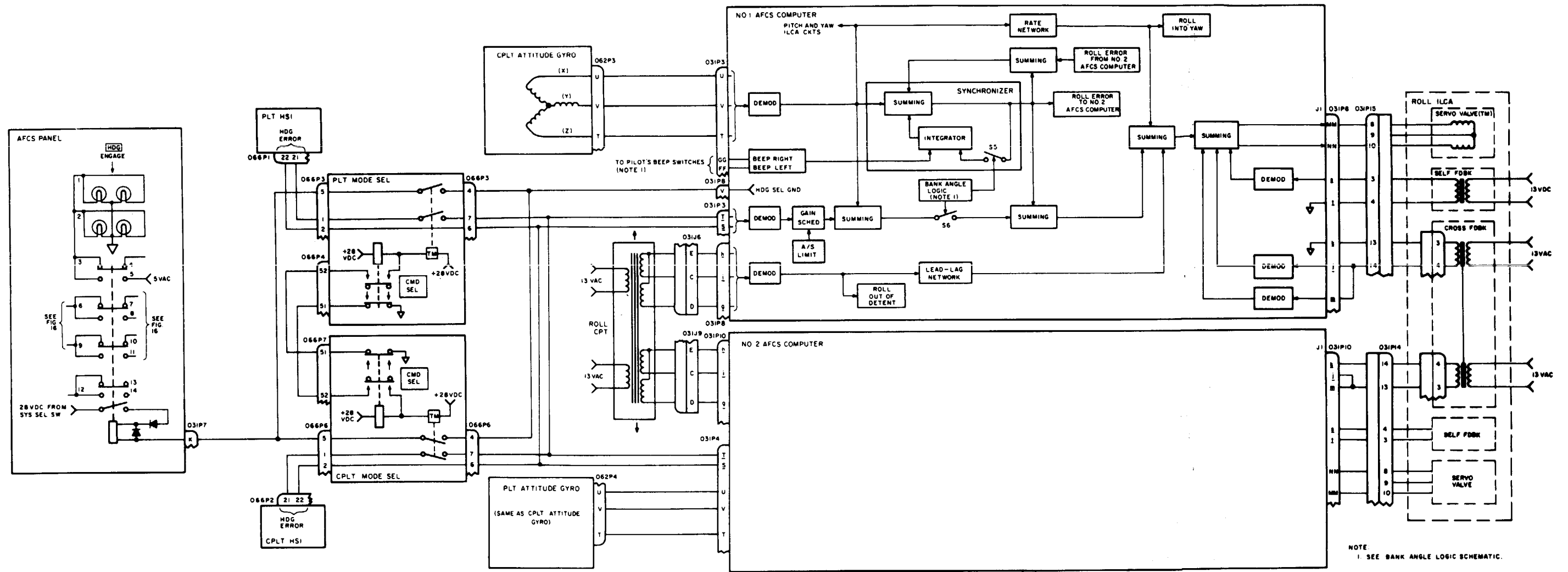

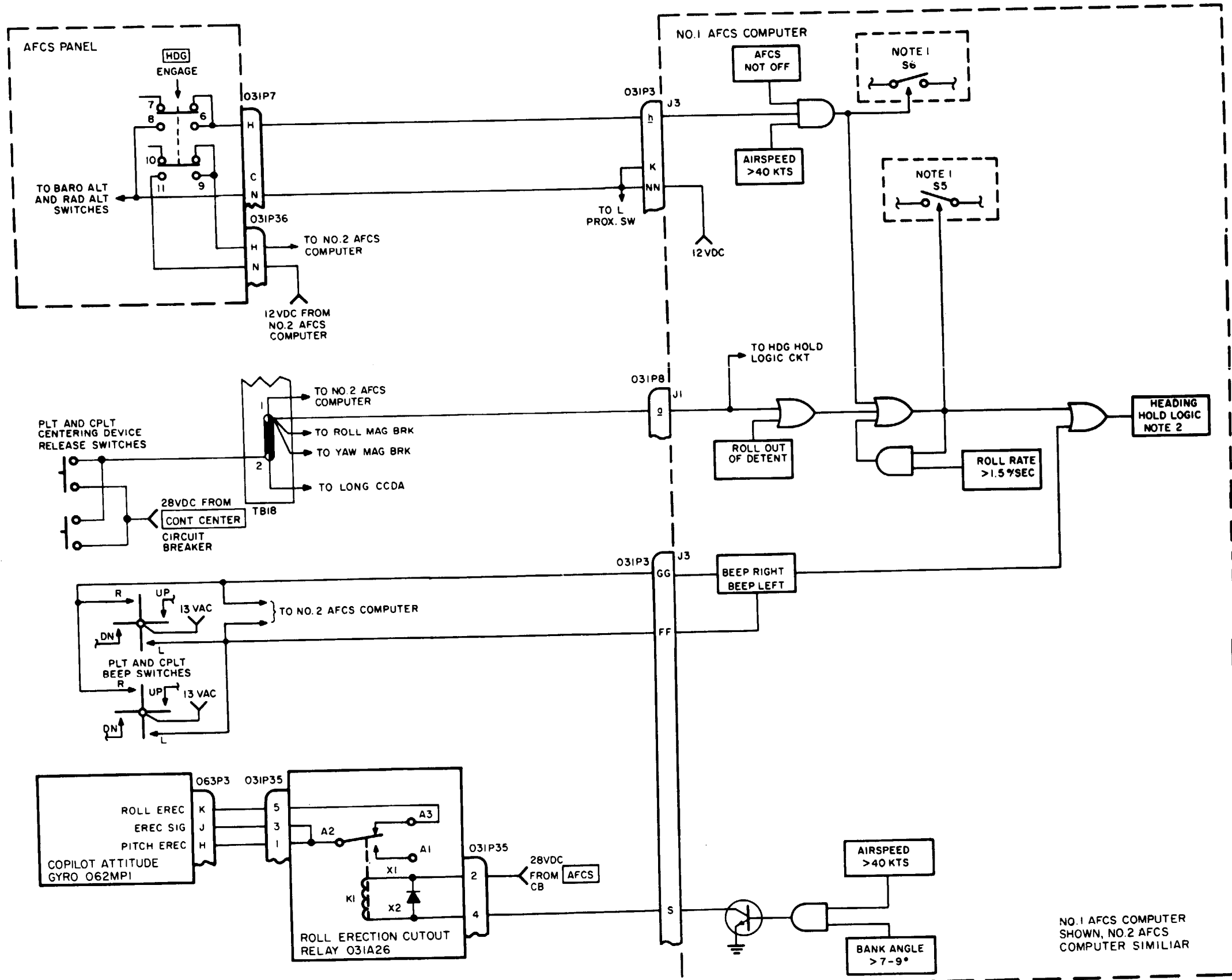

- NOTES
1. SEE ROLL ILCA SIGNAL CIRCUIT SCHEMATIC.
 2. SEE HEADING HOLD LOGIC SCHEMATIC.

NO.1 AFCS COMPUTER SHOWN, NO.2 AFCS COMPUTER SIMILIAR

GO TO NEXT PAGE
Change 3 11-42.5

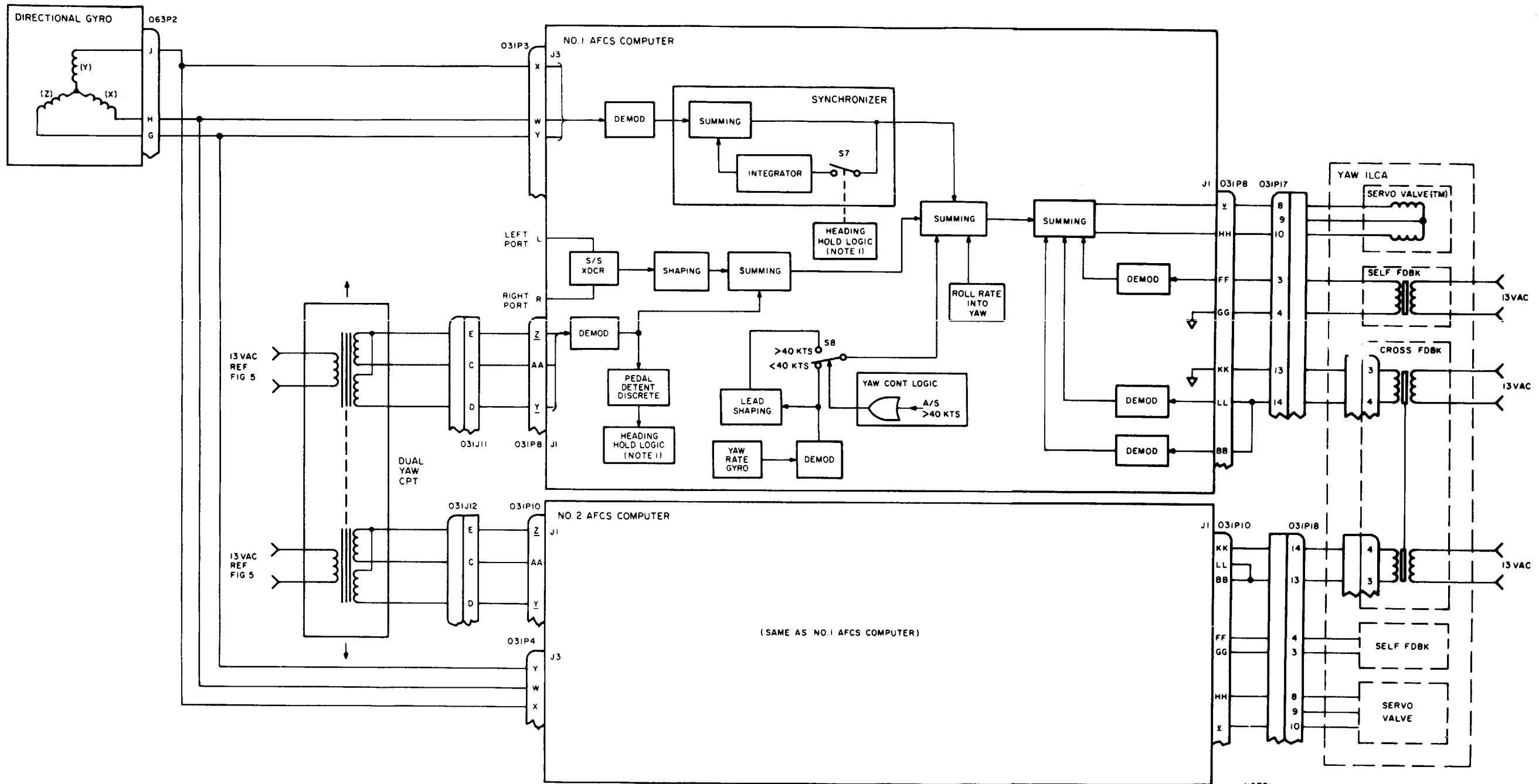

NOTE
1. SEE HEADING HOLD LOGIC SCHEMATIC.

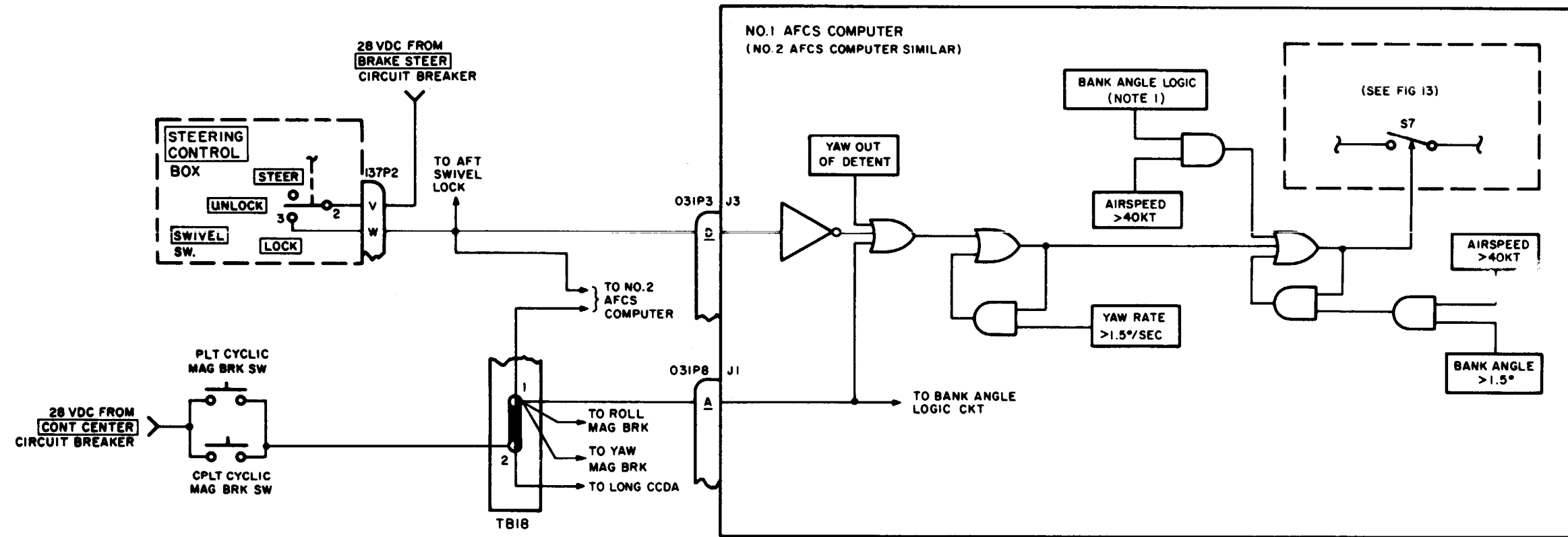

NOTE:
1. SEE BANK ANGLE LOGIC SCHEMATIC

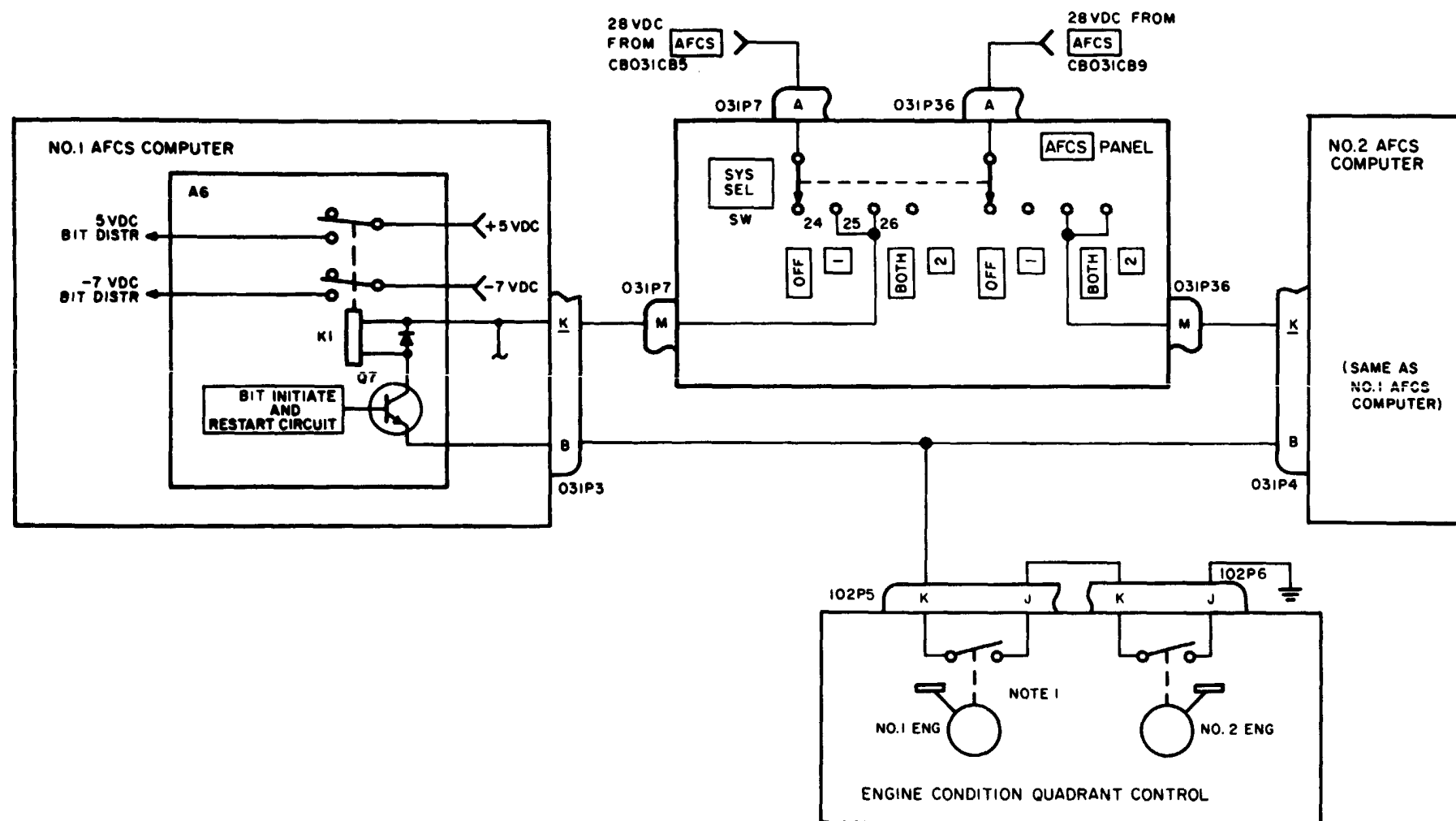

NOTE:
I. SWITCH CLOSED WITH LEVER IN STOP

9608

NO 1 AFCS COMPUTER

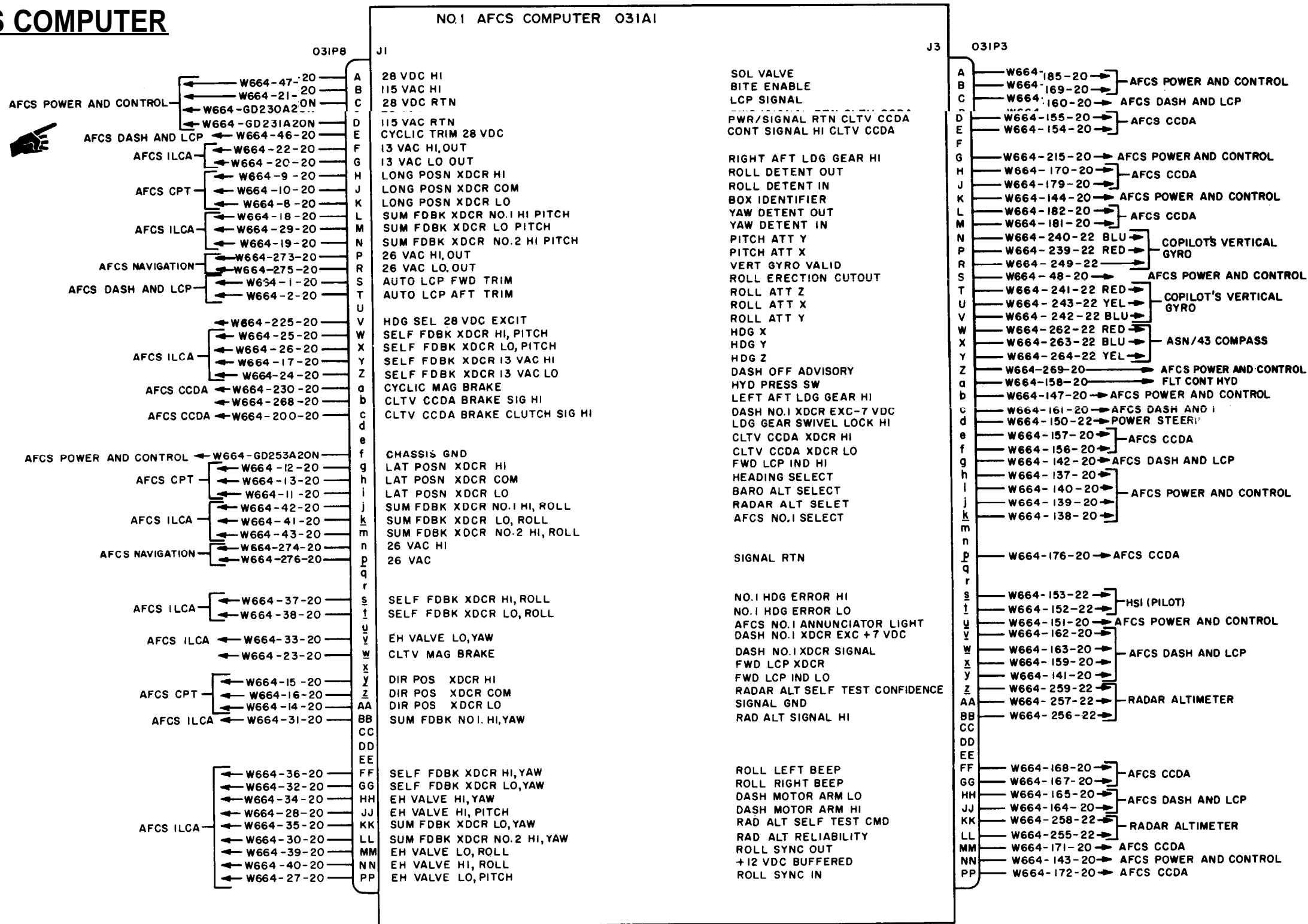

O31-100B

901

NO 2 AFCS COMPUTER

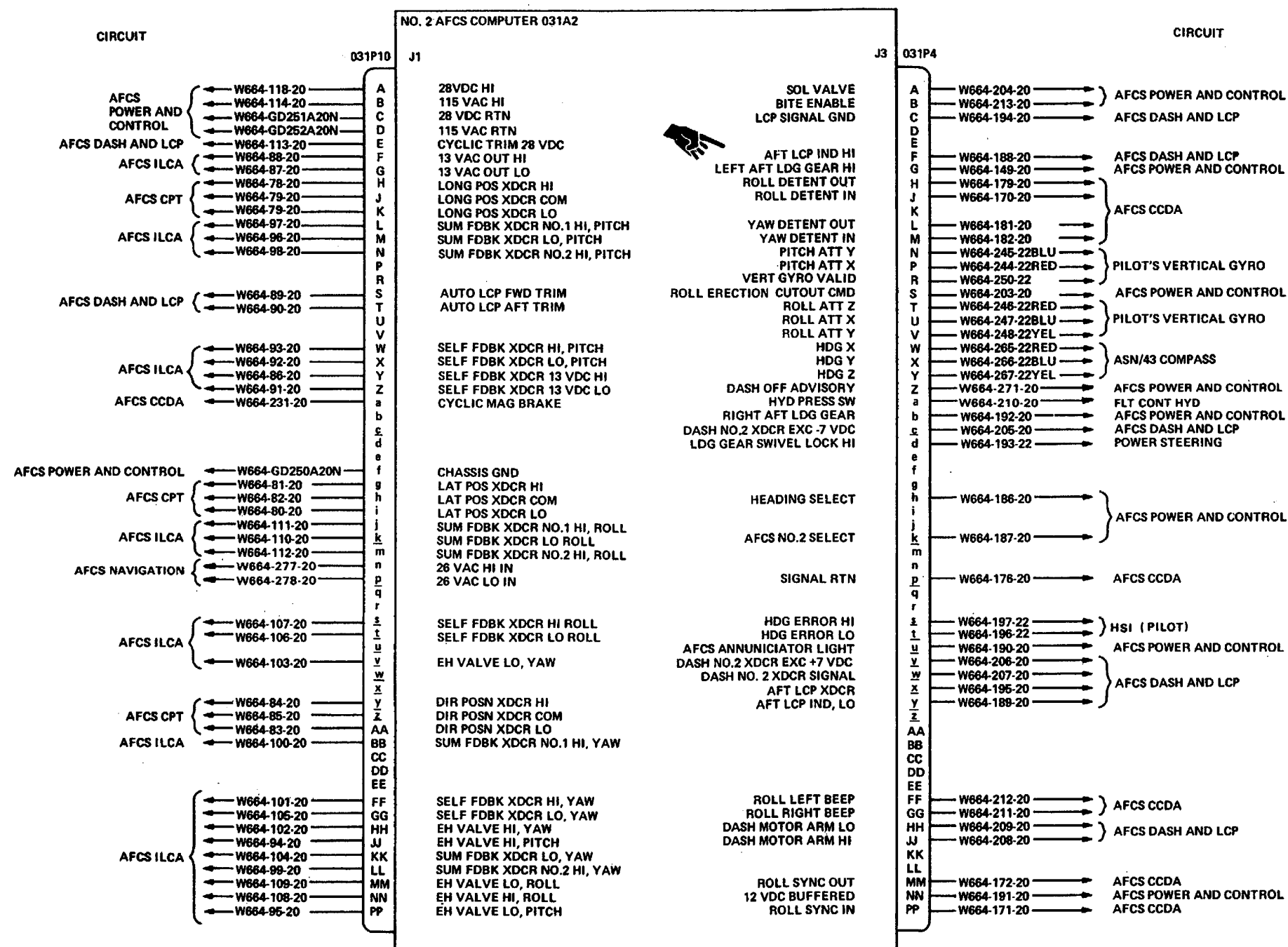

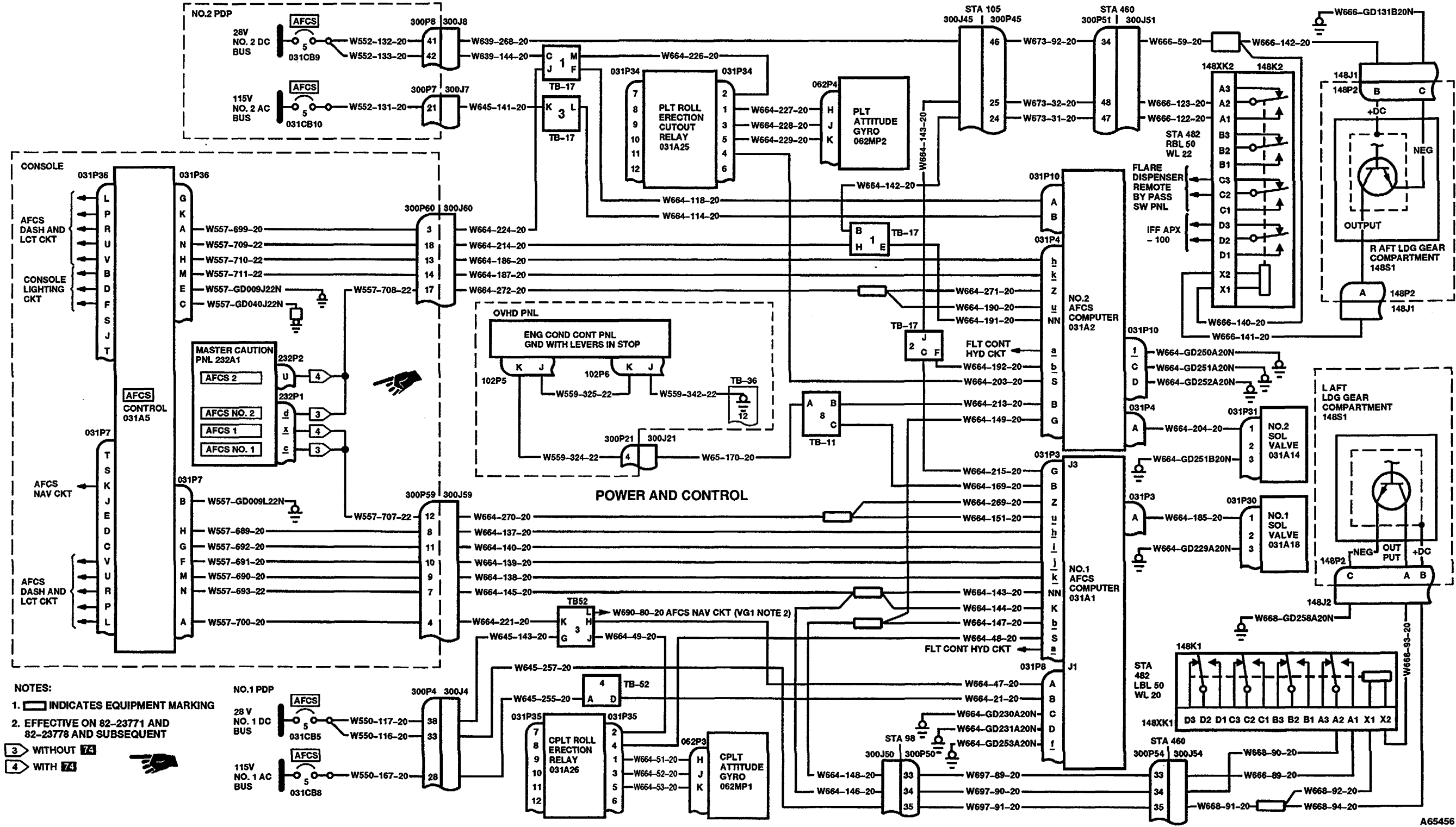

NOTES:
 1. [] INDICATES EQUIPMENT MARKING
 2. EFFECTIVE ON 82-23771 AND 82-23778 AND SUBSEQUENT
 3. WITHOUT []
 4. WITH []

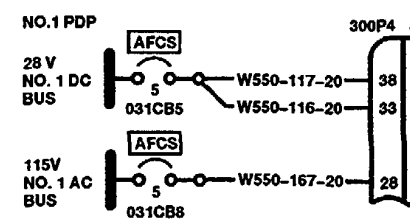

A65456

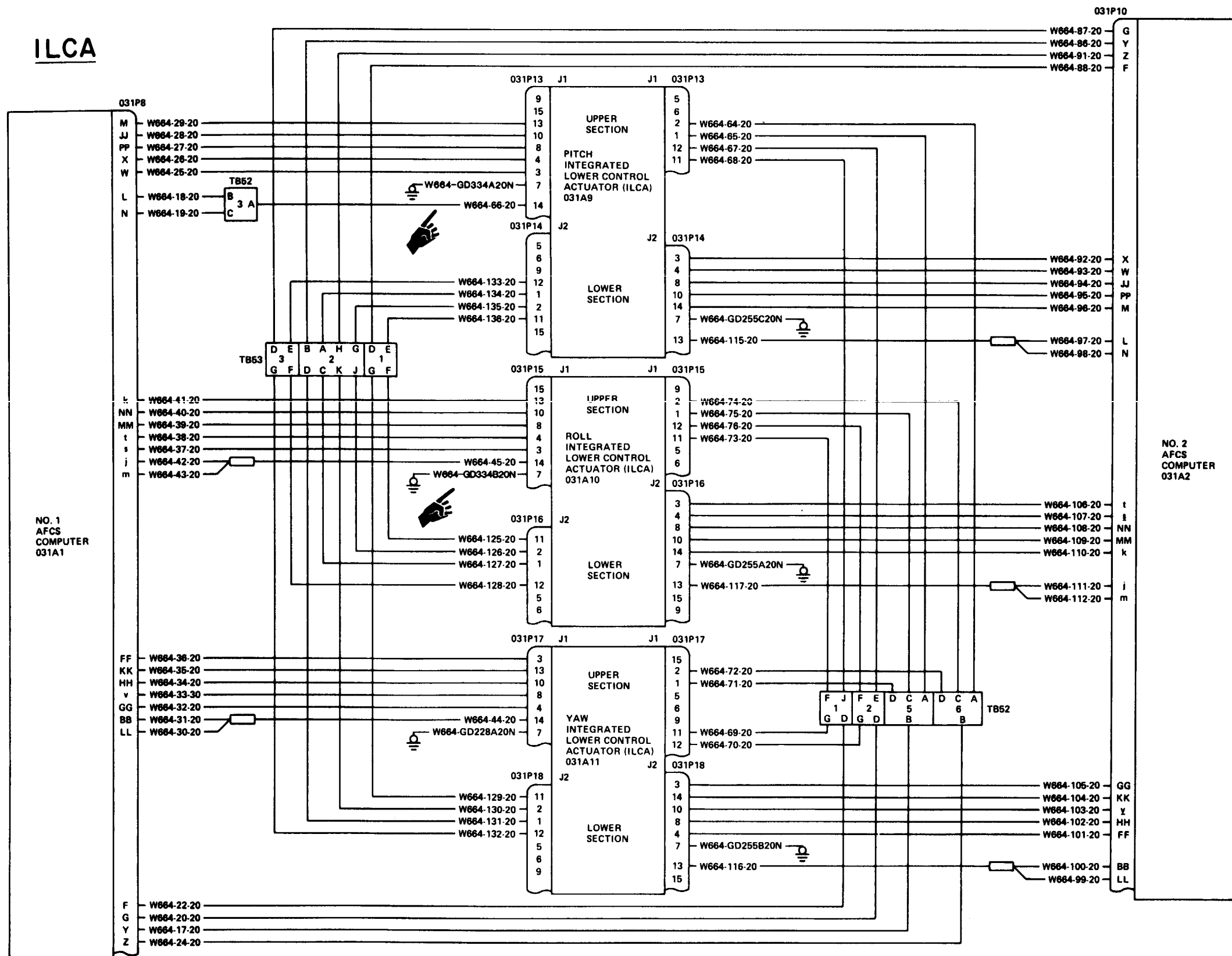

17921

DASH AND LCT ACTUATORS

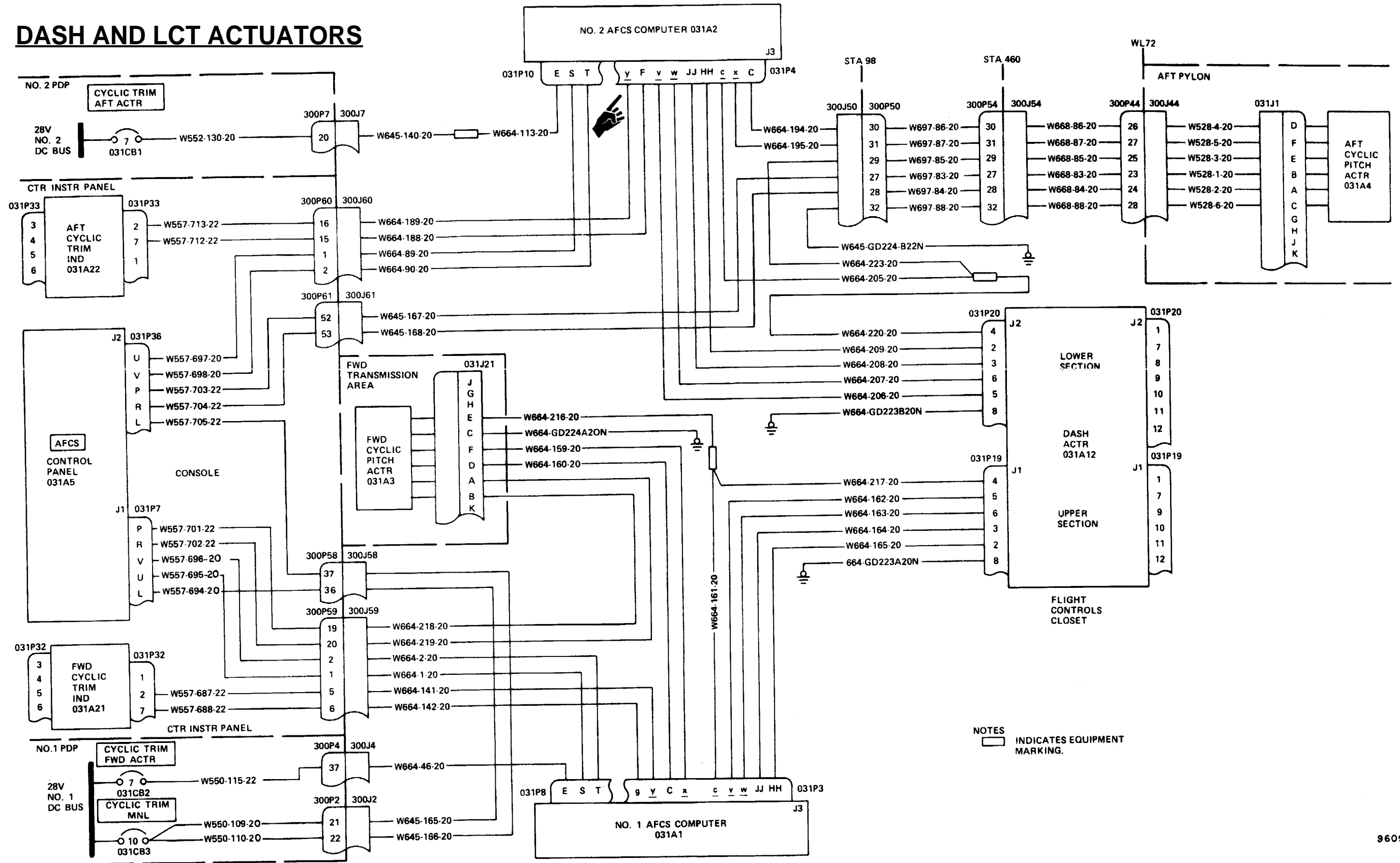

CCDA

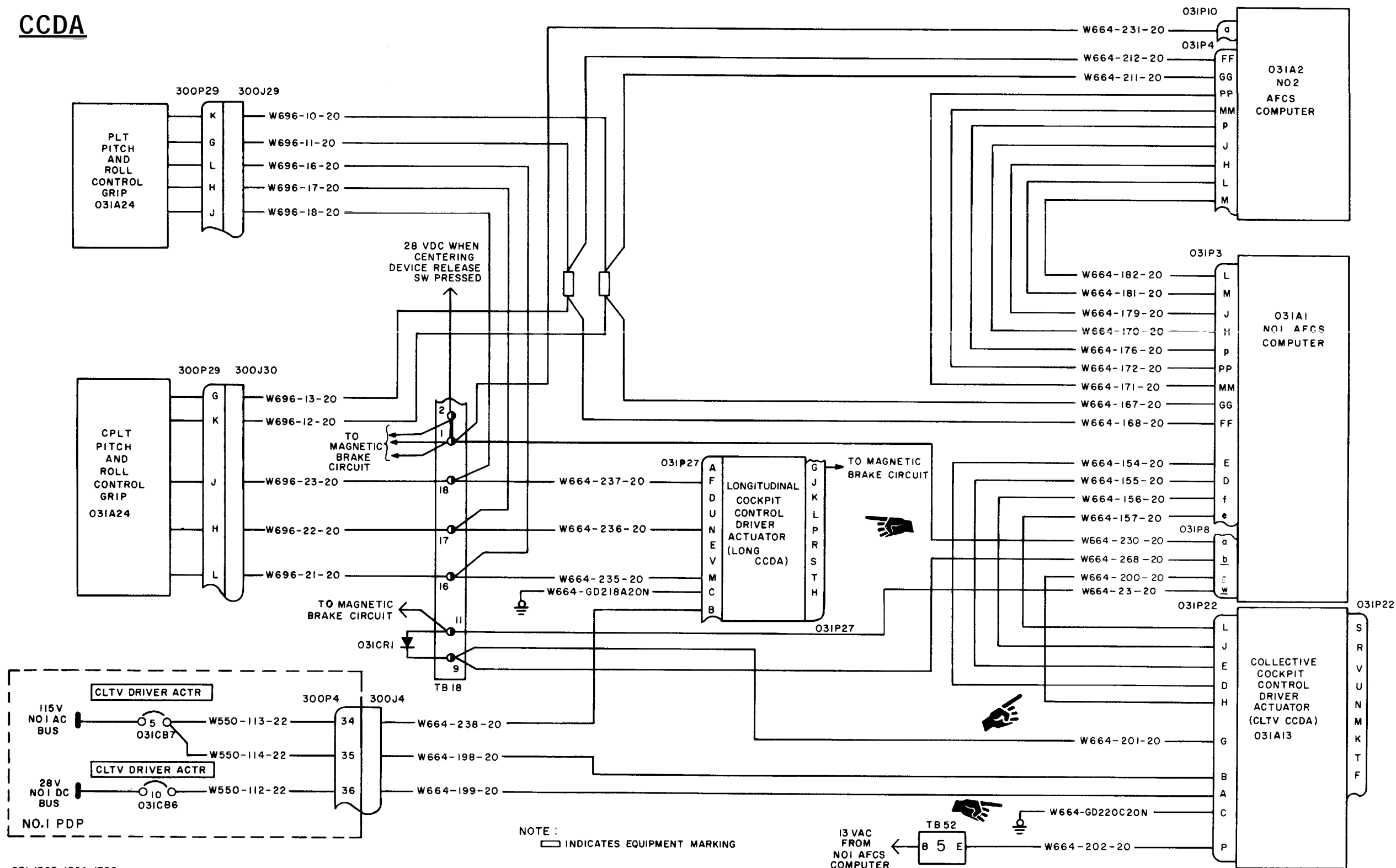

031.130B,150A,170C

904

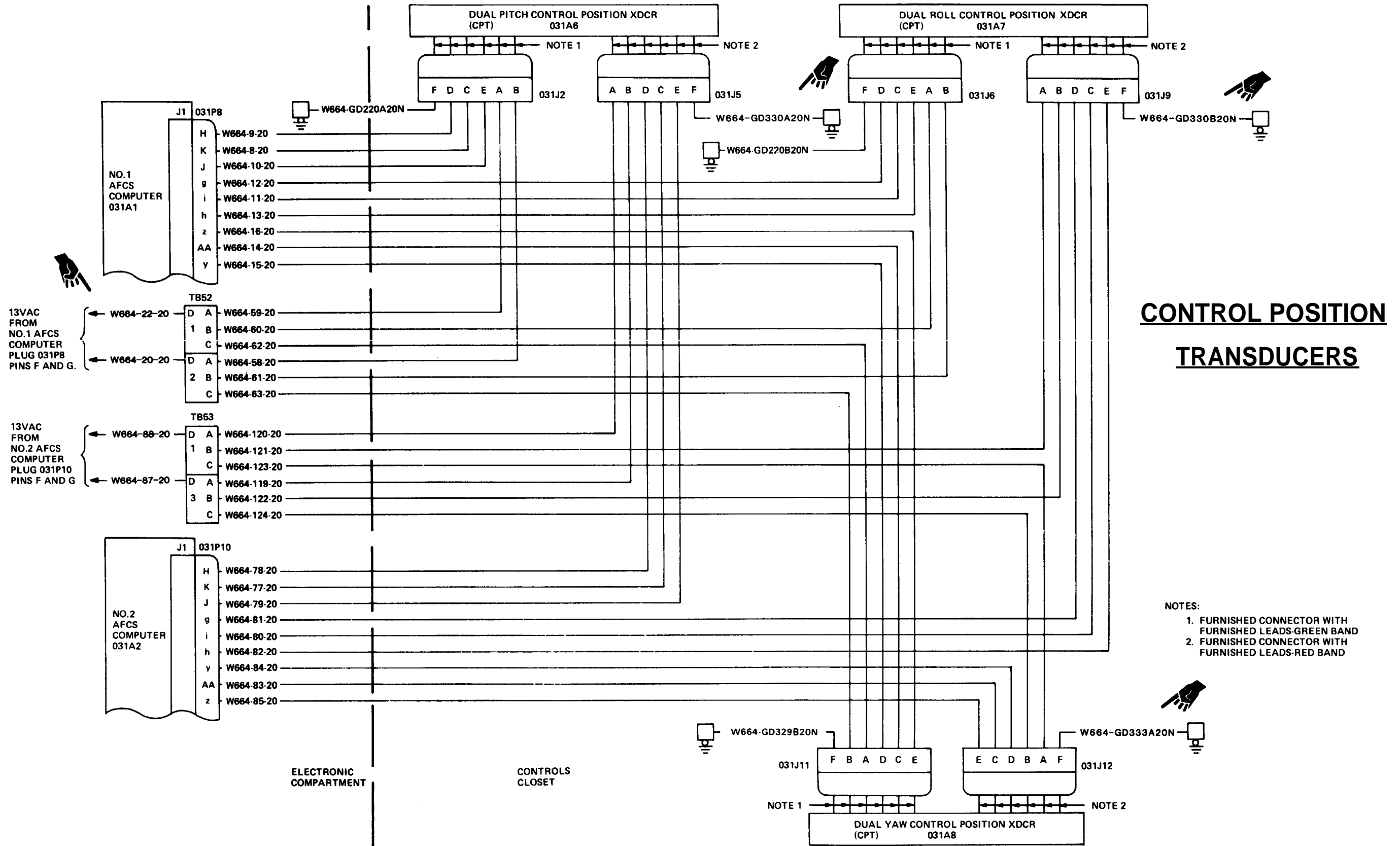

031.138,148

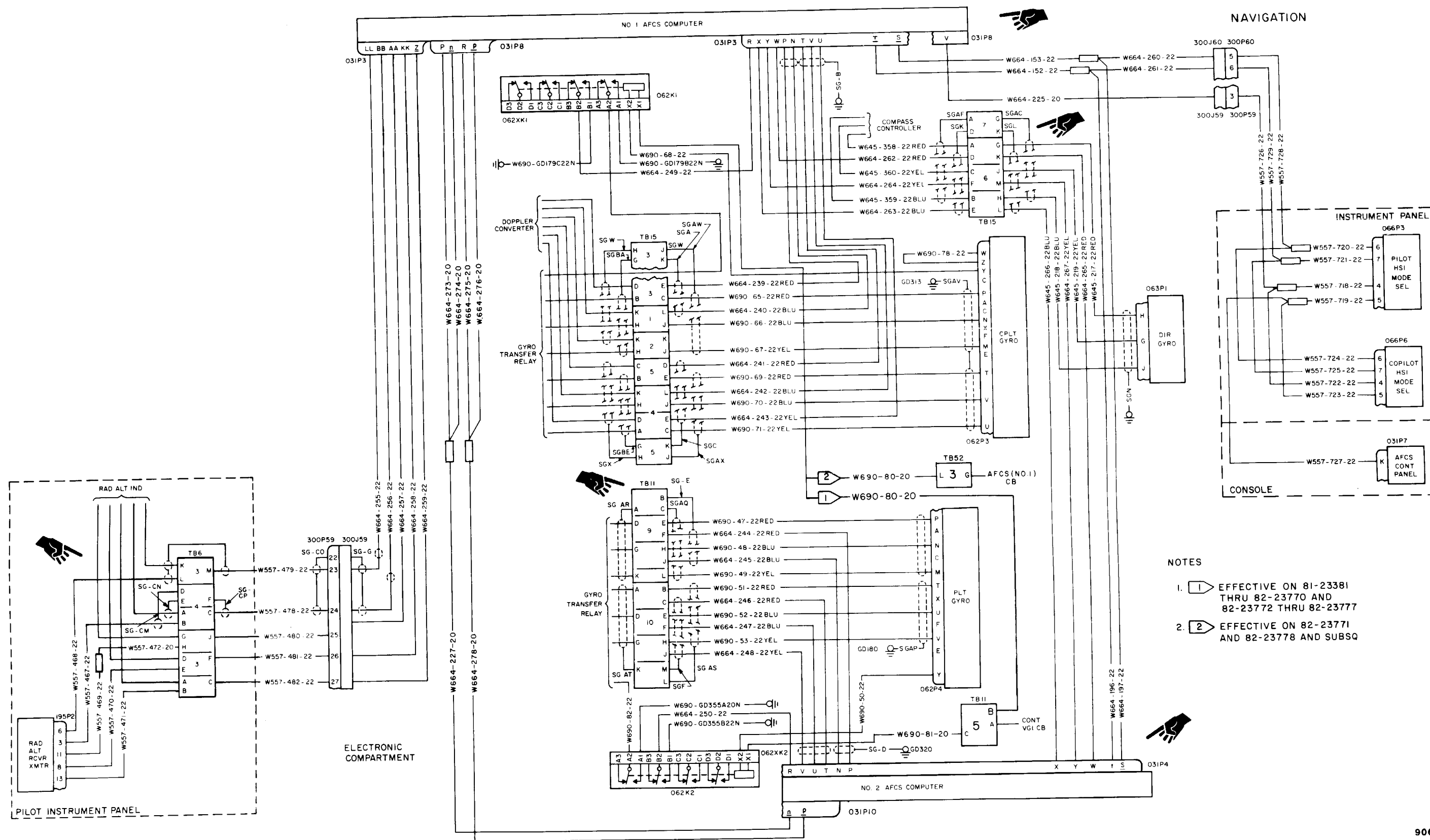

- NOTES
1. EFFECTIVE ON 81-23381 THRU 82-23770 AND 82-23772 THRU 82-23777
 2. EFFECTIVE ON 82-23771 AND 82-23778 AND SUBSQ

11-3.1.2 BITE TEST MEASUREMENT DATA

11-3.1.2

TST NO.	TEST NAME	MONITOR POINT	OUTPUT	DELAY (SEC)	STIM POINT	STIM LEVEL	REMARKS
0	BITE POS. GO	STIM GEN. OUTPUT	< +4.0	.16	MON. MULTIPLEXER	+3.760	
1	BITE POS. NO-GO	STIM GEN. OUTPUT	> +4.0	.16	MON. MULTIPLEXER	+ 4.960	
2	BITE NEG. GO	STIM GEN. OUTPUT	> -4.0	.16	MON. MULTIPLEXER	-3.760	
3	BITE NEG. NO-GO	STIM GEN. OUTPUT	> -4.0	20.48	MON. MULTIPLEXER	-4.960	STOP PUSH BITE
4	DERIVED P. RATE	PELA DRIVE	< -6.0	.0025	PITCH ATT. DEMOD	- .547	
5	CONTINUE	SAME	> -6.0	.0025	SAME	SAME	HI-PASS DECAY
6	LCP AIRSPEED	LCP FDBK POT.	< -2.0	.8	T24 LAG AMP	+2.5	
7	DER. P/R MULTP.	PITCH ILCA DRIVE	< -6.0	.16	SIN, Y/R DEMOD	+4.020	
8	CONTINUE	SAME	> -6.0	.8	SAME	+4.020	HI-PASS DECAY
9	LCP AIRSPEED	LCP FOBK POT.	> -2.0	5.12	NONE		SYNCHRONIZES
10	AUTOMATIC PASS	NONE	> -2.0	.0025	NONE	NONE	
11	DER. R/R-ROLL	ROLL ILCA DRIVE	> +6.0	.0025	SIN DEMOD	+ .940	
12	CONTINUE	R/R LEVEL DET	> +6.0	.0025	SAME	+ .940	
13	CONTINUE	8 DEG R. ATT L DET	> +6.0	.0025	SAME	+ .940	
14	CONTINUE	ROLL ILCA DRIVE	< +6.0	.16	SAME	+ .940	HI-PASS DECAY
15	CONTINUE	R/R LEVEL DET.	< -6.0	.0025	SAME	+ .840	
16	CONTINUE	8 DEG R. ATT L DET	< -6.0	.0025	SAME	0	
11	DER R/R-YAW	YAW ILCA DRIVE	< -6.0	6.82	ROLL RATE AMP	-2.150	
18	LCP ALTITUDE	LCP FDBK POT.	< -2.0	.8	T23 LAG AMP	- 3.520	
19	DASH PITCH ATT.	DASH SUM. AMP	> +4.0	.16	PITCH ATT. DEMOD	+ .117	DASH SW S3 OPEN
20	CONTINUE	SAME	< -4.0	.16	SAME	- .117	DASH SW S3 OPEN
21	DASH AIRSPEED	SAME	> +4.0	.16	T24 LAG AMP	+ .39	DASH SW S3 OPEN
22	CONTINUE	V40 LOGIC	> +3.0	.0025	SAME	+ .38	DASH SW S3 OPEN
23	CONTINUE	SAME	< -4.0	.0025	NONE	NONE	OASH SW S3 OPEN
24	DASH LGT STICK	OASH SUM AMP	< -4.0	.0025	LGT. STICK DEMOD	+ .508	DASH SW S3 OPEN
25	CONTINUE	SAME	> +4.0	.0026	SAME	- .608	DASH SW S3 OPEN
26	BARO ALT. SYNC	CCDA SUM AMP	> -4.0	.64	T23 LAG AMP	-1.52	S9 SYNC
27	BARO ALT. HOLD	SAME	< +4.0	.8	SAME	-1.52	S9 HOLD
28	CONTINUE	SAME	> +4.0	.16	SAME	0	S8 HOLD
29	CCOA RADAR ALT.	SAME	> -4.0	.16	NONE	NONE	S10 SYNC
30	CONTINUE	CCDA SUM AMP	< +4.0	.80	NONE	NONE	S10 HOLD
31	CONTINUE	SAME	< -4.0	.16	RADAR ALT SELFTST	+4.960	S10 HOLD
32	YAW PEDAL POS	YAW ILCA DRIVE	> +6.0	.16	PEDAL CPT DEMOD	+2.030	PED SYNC H. <40
33	CONTINUE	YD LEVEL DET.	> +6.0	.16	SAME	+2.03	PEO SYNC H. <40
34	CONTINUE	SAME	< -6.0	.16	SAME	+ 2.03	PEO SYNC-SYNC
35	HEADING	YAW ILCA DRIVE	< +2.8	.16	NONE		H SYNC-HOLD
36	HEADING SYNC	SAME	< +2.8	.8	HEADING DEMOD	0	H SYNC-SYNC
37	HEADING	SAME	> -4.0	5.3	SAME	0	H SYNC-HOLD
38	CONTINUE	SAME	< -4.0	.16	SAME	- .78	H SYNC-HOLD
39	YAW RATE	YAW ILCA DRIVE	< + 6.0	5.12	NONE		S8 -40 KTS
40	CONTINUE	SAME	< -6.0	.16	YAW RATE DEMOD	-1.679	S8 -40 KTS
41	CONTINUE	SAME	> -6.0	.8	SAME	-1.679	S8 -40 KTS
42	CONTINUE	Y/R LEVEL DET.	> +6.0	.16	SAME	-1.679	S8 -40 KTS
43	CONTINUE	SAME	< -6.0	.16	NONE	NONE	S8 -40 KTS
44	SIDESLIP	YAW ILCA DRIVE	> +6.0	.16	SSLP BUFFER AMP	- .500	S8 -40 KTS
45	ROLL ATTITUDE	ROLL ILCA DRIVE	> +6.0	.16	SIN DEMOD	+ .700	S5 HOLD

TST NO.	TEST NAME	MONITOR POINT	OUTPUT	DELAY (SEC)	STIM POINT	STIM LEVEL	REMARKS
46	CONTINUE	SAME	< +6.0	.16	SAME	+ .700	S5 SYNC
47	CONTINUE	ROLL ATT. ERROR	< -4.0	.16	SAME	+ .700	S5 SYNC, S6C
48	HSI HEADING	SAME	< -4.0	.8	NONE	NONE	HSI BIT C, S6C
49	LAT STICK POS.	ROLL ILCA DRIVE	> +6.0	.8	LAT CPT DEMOD	- 3.00	LAT STK SYNCH
60	CONTINUE	SAME	< +6.0	.8	SAME	- 3.00	LAT STK SYNCH
51	CONTINUE	RD LEVEL OET.	> +6.0	.16	SAME	- 3.00	LAT STK SYNCH
52	CONTINUE	SAME	< -6.0	.16	SAME	- 3.00	SENSOR TORQUE
53	AUTOMATIC PASS	P/R GYRO TORQUE	> -2.0	.0025	P/R GYRO	26VAC	DROP SENS TO
54	NORMAL ACCEL	CCDA SUM AMP	< +4.0	5.92	ACCELEROMETER	+12VDC	SENSOR TOUE
55	AUTOMATIC PASS	NONE	< +2.0	.0025	NONE	NONE	SPARE
56	YAW RATE GYRO	Y/R LEVEL DET.	> +6.0	.0025	Y/R GYRO	26VAC	DROP SENS TO
57	YAW GYRO SMRO	SMRD	> +6.0	.16	NONE (SELF TEST)	NONE	GYRO SMRO OUT
58	AUTOMATIC PASS	NONE	> -2.0	.0025	NONE	NONE	SPARE
59	SAME	NONE	> -2.0	.0025	NONE	NONE	SPARE
TO							
69	SAME	NONE	> -2.0	.0025	NONE	NONE	SPARE
70	PITCH ILCA	PILCA FDBK DEMOD 1	> +4.0	.16	PILCA SUM AMP	-1.250	ENG SOL VALVE
71	CONTINUE	PILCA FOBK DEMOD 2	> +2.0	.16	SAME	-1.260	ENG SOL VALVE
72	CONTINUE	PILCA FOBK DEMOD 3	> +2.0	.16	SAME	-1.250	ENG SOL VALVE
73	CONTINUE	PILCA FOBK DEMOD 3	< +2.0	.16	NONE	NONE	ENG SOL VALVE
74	CONTINUE	NONE	> -2.0	.0025	NONE	NONE	SPARE
75	YAW ILCA	YILCA FOBK DEMOD 1	> +4.0	.16	PEDAL CPT DEMOD	+2.030	ENG SOL VALVE
76	CONTINUE	YILCA FOBK DEMOD 2	> +2.0	.16	SAME	+2.030	SAME
77	CONTINUE	YILCA FDBK DEMOD 3	> +2.0	.16	SAME	+2.030	SAME
78	SAME	SAME	< +2.0	.16	NONE	NONE	SAME
79	AUTOMATIC PASS	NONE	> -2.0	.0026	NONE	NONE	SPARE
80	ROLL ILCA	RILCA FDBK DEMOD 1	> +4.0	.16	RILCA SUM AMP	-1.560	ENG SOL VALVE
81	CONTINUE	RILCA FDBK DEMOD 2	> +4.0	.16	SAME	SAME	SAME
82	CONTINUE	RILCA FDBK DEMOD 3	> +2.0	.16	SAME	-1.56	SAME
83	CONTINUE	SAME	< +2.0	.16	NONE	NONE	SAME
84	AUTOMATIC PASS	NONE	> -2.0	.0025	NONE	NONE	SAME
85	DASH ACTUATOR	DASH FDBK POT	< -3.0	.6	DASH DRIVER AMP	+4.961	DASH S3 OPEN
86	CONTINUE	SAME	> +3.0	.8	SAME	-5.000	SAME
87	CCDA	CCDA LEAD-LAG OUTP.	> +4.0	.8	CCDA MODULATOR	+2.031	AFCS 1, S12, 14 SYNC
88	AUTOMATIC PASS	NONE	> -2.0	.0025	NONE	NONE	SPARE
89	LG. STK POS TDCR	LONG. SPT LEVEL DET.	< -3.0	.16	NONE	NONE	
90	AUTOMATIC PASS	NONE	> -2.0	.0025	NONE	NONE	SPARE
91	PEDAL POS TDCR	PEDAL POS LEVEL DET	< -3.0	.16	NONE	NONE	
92	AUTOMATIC PASS	NONE	> -2.0	.0025	NONE	NONE	SPARE
93	LAT STK POS TDCR	LATERAL CPT L/DET.	< -3.0	.16	NONE	NONE	
94	AUTOMATIC PASS	NONE	> -2.0	.0025	NONE	NONE	SPARE
95	RADAR ALTIMETER	RADAR ALT CONF SIG	> +4.0	.16	RADAR ALT SELFTST	+4.960	NO. 1 AFCS ONLY
96	AUTOMATIC PASS	NONE	> -2.0	.0025	NONE	NONE	SPARE
TO							
127	AUTOMATIC PASS	NONE	> -2.0	.0025	NONE	NONE	SPARE

11-3.2 AFCS VISUAL CHECK

INITIAL SETUP

Applicable Configurations:
All

Tools:
Aircraft Mechanic's Tool Kit,
NSN 5180-00-323-4692

Materials:
None

Personnel Required:
35K10 Avionic Mechanic

References:
TM 55-1520-240-23

Equipment Condition:
TM 55-1520-240-23
Battery Disconnected
Electrical Power Off
Hydraulic Power Off
Pylon Left Work
Platform Open
Forward Left Work
Platform Open
Flight Controls Closet Acoustic
Blanket Removed
Electronic Compartment Acoustic
Blanket Removed
Flight Controls Closet Panel
Open

TASK	RESULT
1. Check AFCS panel.	If knob (1) is loose, tighten it. If any switch (2 or 3) is damaged, replace AFCS panel.
2. Check FWD and AFT CYC TRIM indicators (4 and 5).	If either indicator (4 or 5) is damaged, replace it.
3. Check pilot's radar altimeter (6).	If altimeter (6) is damaged, replace it.
4. Check pilot's HSI (7).	IF HSI (7) is damaged, replace it.
5. Check pilot's HSI MODE SELECT panel (8).	If panel (8) is damaged, replace it.
6. Check pilot's pitch and roll trim switch (9).	If switch (9) is damaged. replace it.
7. Repeat steps 4, 5, and 6 for copilot's radar altimeter HSI, and HSI MODE SELECT panel (6, 7, and 8). then go to step 8.	
8. Check copilot's pitch and roll trim switch (9).	If switch (9) is damaged, replace it.

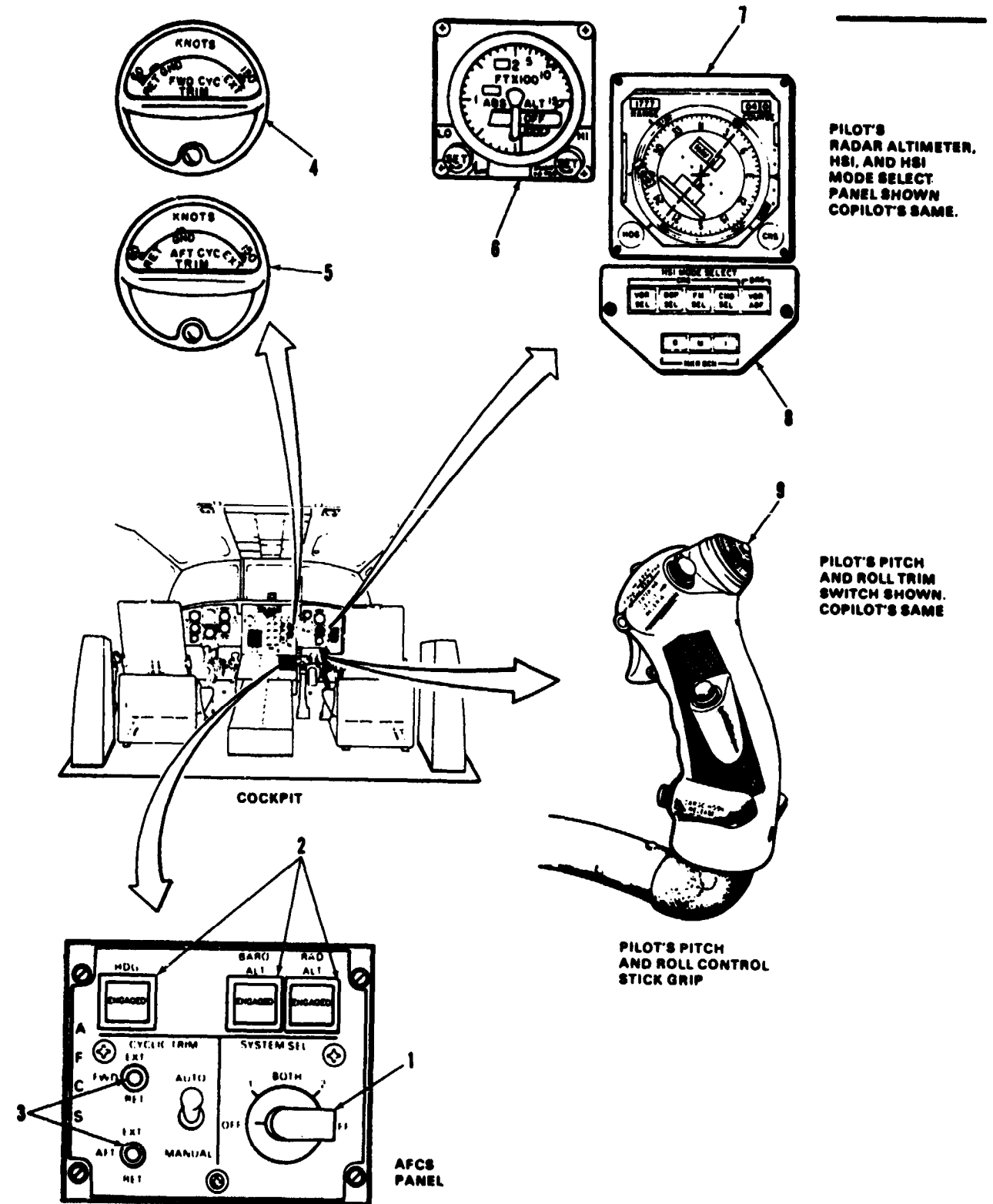

TASK	RESULT
9. Check NO. 1 AFCS computer (10).	If computer (10) is loose or damaged, tighten or replace it as required. If any of four lines (11) are loose or damaged, tighten or replace them as required. If either connector (12) is loose or damaged, tighten or replace it as required. If wiring to either connector (12) is damaged, repair or replace it as required.
10. Check NO. 2 AFCS computer (13).	If computer (13) is loose or damaged, tighten or replace it as required. If any of four lines (14) are loose or damaged, tighten or replace them as required. If either connector (15) is loose or damaged, tighten or replace it as required. If wiring to either connector (15) is damaged, repair or replace it as required.
11. Check directional gyro (16).	If gyro (16) is damaged, replace it. If connector to gyro is loose or damaged, tighten or replace it as required. If wiring to connector is damaged, repair or replace it as required.
12. Check pilot's vertical gyro (17).	If gyro (17) is damaged, replace it. If connector to gyro is loose or damaged, tighten or replace it. If wiring to connector is damaged, repair or replace it as required.
13. Check copilot's vertical gyro (18).	If gyro (18) is damaged, replace it. If connector to gyro is loose or damaged, tighten or replace it. If wiring to connector is damaged, repair or replace it as required.

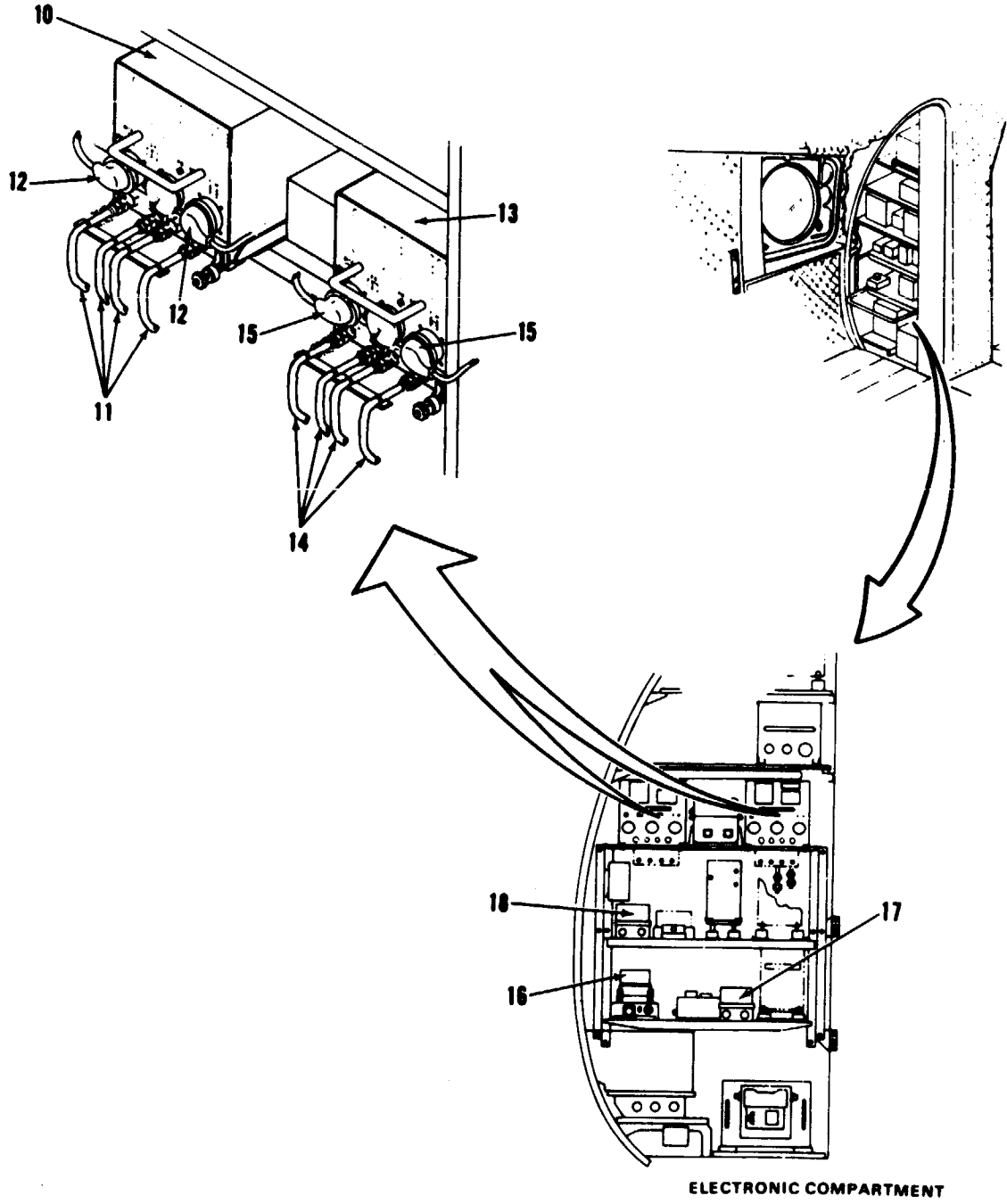

TASK	RESULT
14. Check yaw linear transducer (cpt) (19).	If transducer (19) is damaged, replace it. If either connector (10) is loose or damaged, tighten or replace it. If wiring to either connector is damaged, replace transducer.
15. Check collective cockpit control driver actuator (ccda) (21).	If ccda (21) is loose or damaged, tighten or replace it as required. If connector to ccda is loose or damaged, tighten or replace it as required. If wiring to connector is damaged repair or replace it as required.
16. Check dash actuator (22).	If actuator (22) is damaged, replace it. If connector (23 or 24) is loose or damaged, tighten or replace it as required. If wiring to either connector is damaged, repair or replace it as required.
17. Check pitch and roll linear transducer (25).	If either transducers (25) is damaged, replace it. If any connector (26) is loose or damaged, tighten or replace it as required. If wiring to any connector is damaged, replace transducer.
18. Check longitudinal ccda (27).	If ccda (27) is loose or damaged, tighten or replace it as required. If connector to ccda is loose or damaged, tighten or replace it as required. If wiring to connector is damaged, repair or replace it as required.
18.1 Check all electrical connectors in flight control closet.	If any connector contains hydraulic fluid, clean it thoroughly.

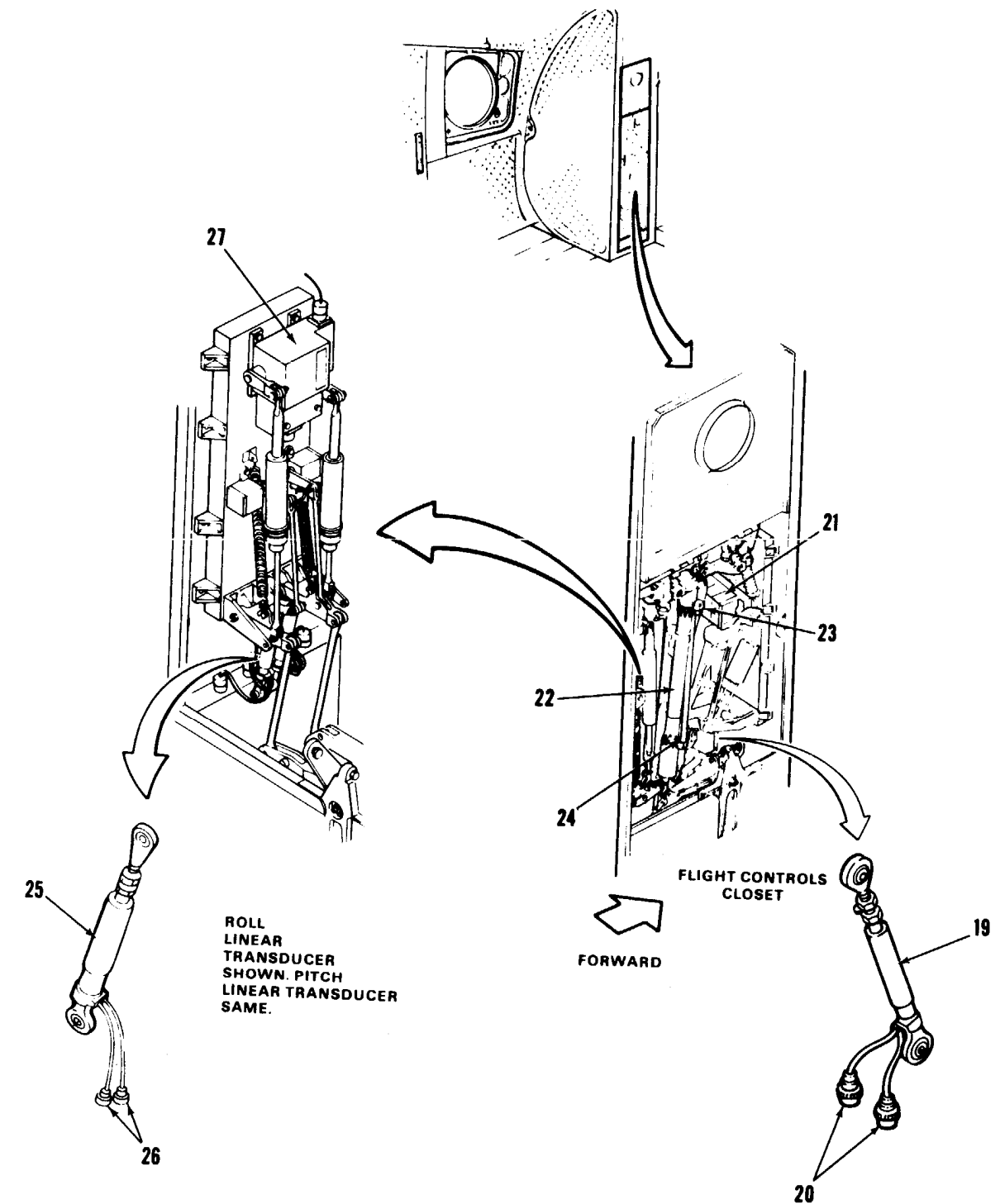

45 x 54

D145-11660-SPA

11-3.2 AFCS VISUAL CHECK (Continued)

TASK	RESULT
19 Check aft longitudinal cyclic trim actuator (28).	If actuator (28) is damaged, replace it. If connector to actuator is loose or damaged, tighten or replace it as required. If wiring to connector is damaged, repair or replace it as required.
20 Check forward longitudinal cyclic trim actuator (29).	If actuator (29) is damaged, replace it. If connector to actuator is loose or damaged, tighten or replace it as required. If wiring to connector is damaged, repair or replace it as required.

FOLLOW-ON MAINTENANCE:

- TM 55-1520-240-23:
- Close Flight Controls Closet Panel
- Flight Controls Closet Acoustic Blanket Installed
- Forward Left Work Platform Closed
- Pylon Left Work Platform Closed

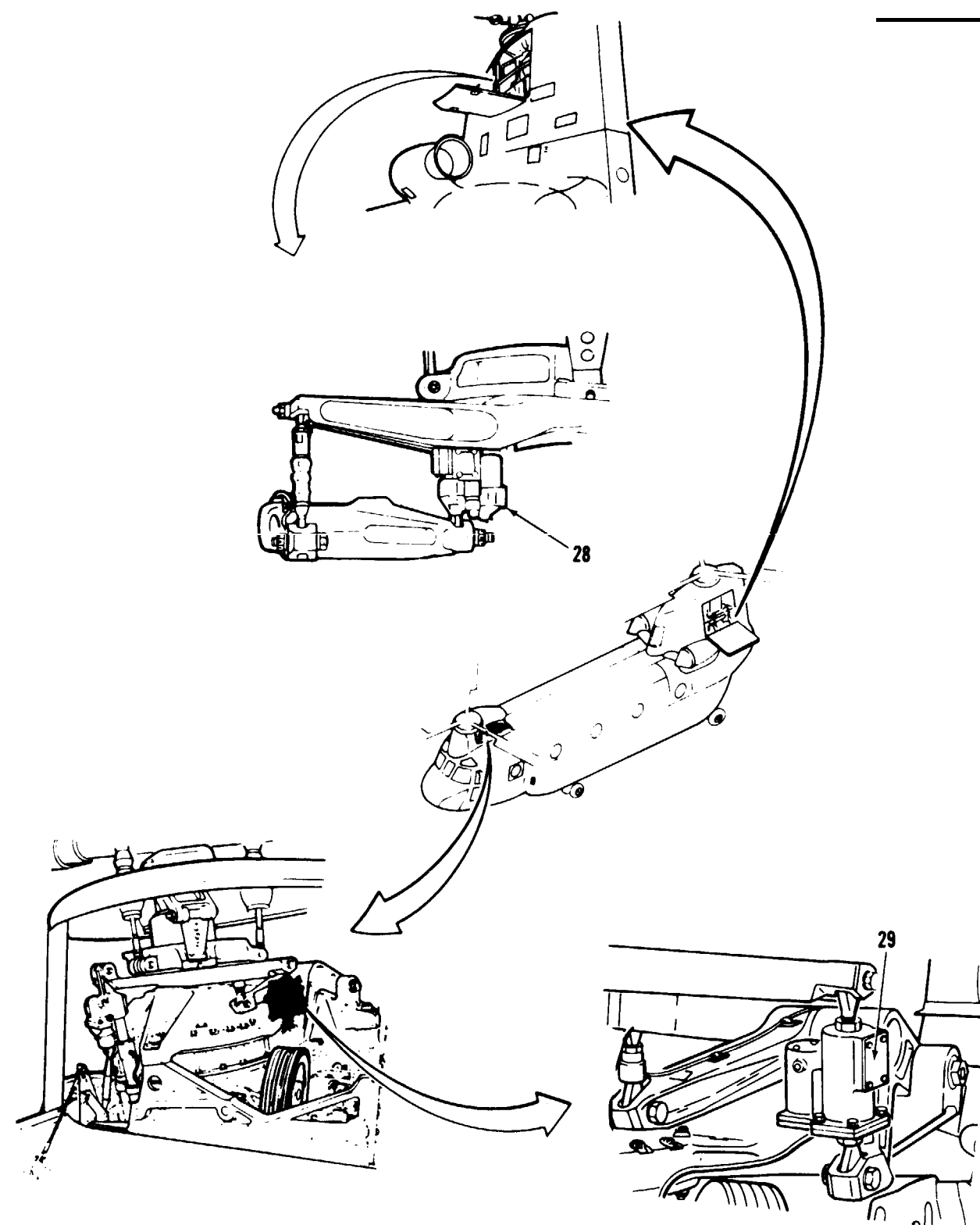

INITIAL SETUP

Applicable Configurations:
All

Tools:
None

Materials:
None

Personnel Required:
35K20 Avionic Mechanic

References:

- TM 11-1520-240-20
- TM 55-1520-240-23

Equipment Condition:

- TM 55-1520-240-23:
- Battery Connected
- Electrical Power On
- Hydraulic Power On
- Aircraft Weight Supported By Its Own Wheels.
- Visual Check of AFCS Performed (Task 11-3.2)

TASK	RESULT
------	--------

CHECK CIRCUIT BREAKERS

1. Check that following circuit breakers in NO. 1 PDP are closed:
AC
AFCS NO. 1 (1)
CLTV DRIVER ACTR (2)
NAV COPLT VGI (3)
NAV COPLT HSI (4)
NAV CMPS (5)
NAV COPLT HSI (6)
NAV CMPS (7)
DC
AFCS NO. 1 (8)
CLTV DRIVER ACTR (9)
CYCLIC TRIM MNL (10)
and FWD ACTR (11)
NAV COPLT HSI
MODE SEL (12)
HYDRAULICS BRAKE STEER (13)
CONT CENTER (14)
THRUST BRAKE (15)

- If any circuit breaker (1 through 14) is open close it. If AFCS NO. 1 circuit breaker (1) opens again, go to task 11-3.4.
- If CLTV DRIVER ACTR circuit breaker (2) opens again, go to task 11-3.5.
- If NAV COPLT VGI, COPLT HSI, CMPS, COPLT HSI, CMPS circuit breaker (3, 4, 5, 6, or 7) open again, refer to TM 11-1520-240-20.
- If AFCS NO. 1 circuit breaker (8) opens again, go to task 11-3.6.
- If CLTV DRIVER ACTR circuit breaker (9) opens again, go to task 11-3.7.
- If CYCLIC TRIM MNL circuit breaker (10) opens again, go to task 11-3.8
- If CYCLIC TRIM FWD ACTR circuit breaker (11) opens again, go to task 11-3.9.
- If NAV COPLT HSI MODE SEL circuit breaker (12) opens again, refer to TM 11-1520-240-20.
- If BRAKE STEER circuit breaker (13) opens again, go to task 7-4.4.
- If CONT CENT or THRUST BRAKE circuit breaker (14 or 15) opens again, go to task 11-2.3.

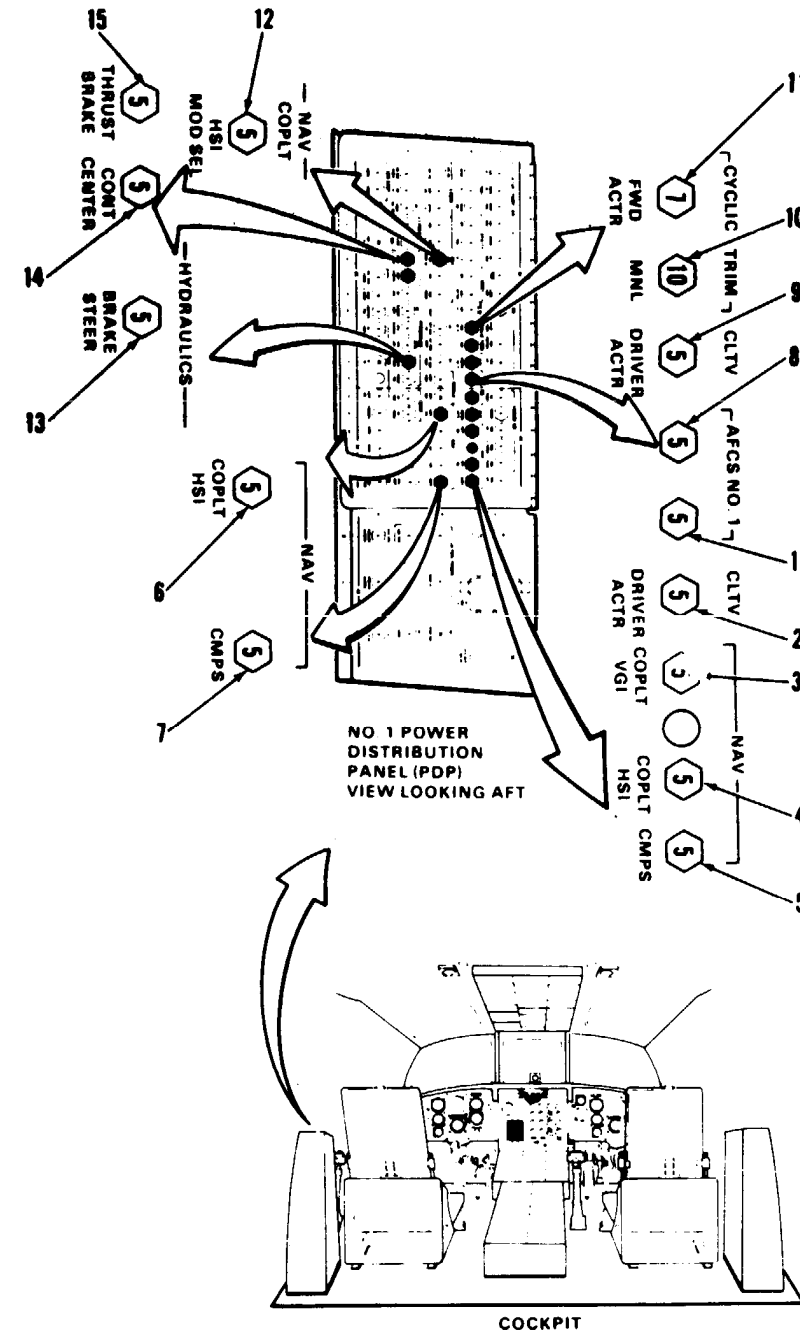

45x54

D145-11662-SPA

TASK	RESULT
<p>2. Check that following circuit breakers in NO. 2 PDP are closed.</p> <p>AC AFCS NO. 2 (16) NAV PILOT VGI (17) NAV PLT HSI (19)</p> <p>DC AFCS NO. 2 (20) CYCLIC TRIM AFT ACTR (21) NAV CONT VG 1 (22) NAV RAD ALT (23) NAV PLT HSI MODE SEL (24)</p>	<p>If any circuit breaker (16 through 24) is open, close it. If AFCS NO. 2 circuit breaker (16) opens again, go to task 11-3.10.</p> <p>If NAV PILOT VGI, PLT HSI or PLT HSI circuit breaker (17, 18, or 19) opens again, refer to TM 11-1520-240-20 for troubleshooting information</p> <p>If AFCS NO. 2 circuit breaker (20) opens again, go to task 11-3.11.</p> <p>If CYCLIC TRIM AFT ACTR circuit breaker (21) opens again, go to task 11-3.12. If NAV CONT VGI, RAD ALT, or PLT HSI MODE SEL circuit breaker (22, 23, or 24) opens again, refer to TM 11-1520-240-20 for troubleshooting information.</p>
<p>CHECK NO. 1 AFCS</p> <p>3. Press and hold pilot's CENTERING DEVICE RELEASE switch (25). Center pilot's pitch, roll control stick, and directional pedals. Release CENTERING DEVICE RELEASE switch.</p>	<p>Control stick and directional pedals shall center easily and remain there after CENTERING DEVICE RELEASE switch (25) is released. If not, go to task 11-2.3.</p>

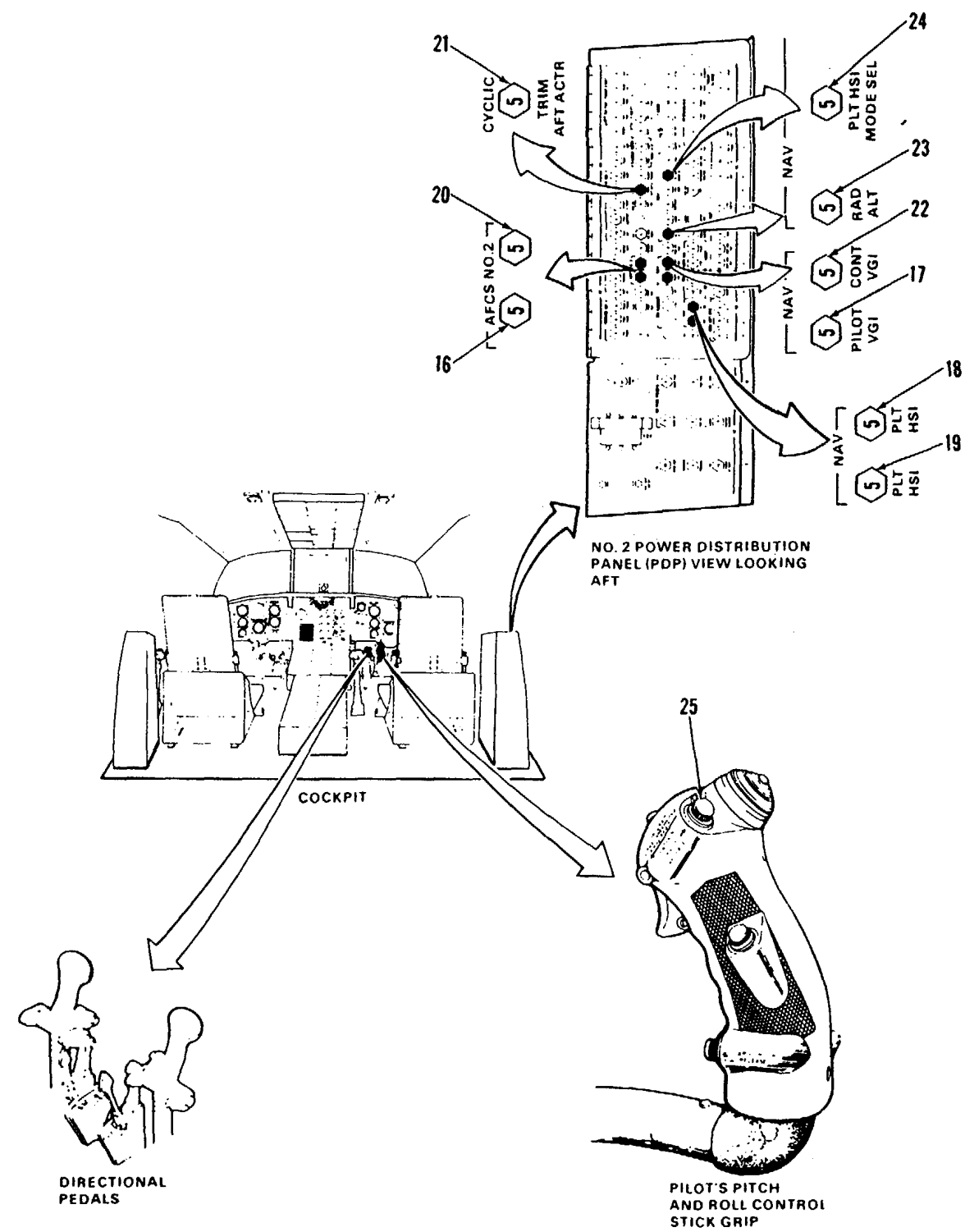

45X54

0145-11663-SPA

11-3.3 AFCS OPERATIONAL CHECK (Continued)

11-3.3

TASK	RESULT	TASK	RESULT
4. Set SYSTEM SEL switch (26) to OFF.	NO. 1 AFCS OFF and NO. 2 AFCS OFF (Without 74) AFCS 1 and 2 (With 74) capsules (27 and 28) shall come on. If NO. 1 AFCS OFF (Without 74) AFCS 1 (With 74) capsule (27) is out, go to Task 11-3.13. If NO. 2 AFCS OFF (Without 74) AFCS 2 (With 74) capsule (28) is out, go to Task 11-3.14.	12. Set SYSTEM SEL switch (26) to 1.	NO. 1 AFCS OFF (Without 74) AFCS 1 (With 74) capsule (27) shall go out. No large Integrated Lower Control Actuator (ILCA) engagement transients (hardovers) shall occur. If capsule (27) is still on, go to Task 11-3.18. If large ILCA engagement transients (hardovers) occurs, go to Task 11-3.19 for pitch transient, Task 11-3.20 for roll transient, or Task 11-3.21 for yaw transient.
5. Set SWIVEL switch (29) to LOCK.		13. Move pilot's directional pedals right, then left. Return pedals to center.	No. 1 Yaw ILCA output shaft shall extend with pedal right and retract with pedal left. If No. 1 yaw ILCA output shaft does not extend or retract, go to Task 11-3.22.
6. Turn pilot's radar altimeter LO SET knob (30) until lo set index (31) is at 100.	Radar altimeter OFF flag shall go out of view. Digital readout shall indicate 0 to 5 feet after 1 minute warmup. If OFF flag is still in view or digital indication is not 0 to 5 feet, refer to TM 11-1520-240-20 for troubleshooting information.	14. Move pilot's pitch and roll control stick right, then left. Return grip to center.	No. 1 roll ILCA output shaft shall extend with stick right and retract with stick left. If No. 1 roll ILCA output shaft does not extend or retract, go to Task 11-3.23.
7. Turn pilot's HSI HDG knob (32) until heading cursor (33) is 30° degrees clockwise from aircraft heading.		15. Momentarily set pilot's pitch and roll trim switch (40) right then left. Release switch.	No. 1 roll ILCA output shaft shall extend when switch (40) is right and retract when switch is left. If No. 1 roll ILCA output shaft does not extend or retract, go to Task 11-3.24.
8. Press and release pilot's CMD SEL switch (34).	CMD SEL caption shall come on. If it does not, refer to TM 11-1520-240-20.	15.1 Momentarily set co-pilot's pitch and roll trim switch (40) right then left. Release switch.	No. 1 roll ILCA output shaft shall extend when switch (40) is right and retract when switch is left. If No. 1 roll ILCA output shaft does not extend or retract, go to Task 11-3.24.
9. Check that both ENGINE CONDITION levers (35 and 36) are at STOP.	Set them to STOP if required.	16. Press and hold pilot's CENTERING DEVICE RELEASE switch (25). Center pilot's pitch and roll control stick and directional pedals. Release CENTERING DEVICE RELEASE switch.	
10. Check that CYCLIC TRIM AUTO MANUAL switch (37) is at AUTO.	Set switch to AUTO if required.		
11. Check FWD and AFT CYC TRIM indicators (38 and 39).	Pointers on both indicators (38 and 39) shall be in GND position. If both pointers are not in GND position, go to Task 11-3.15. If FWD CYC TRIM indicator pointer is not as GND position, go to Task 11-3.16. If AFT CYC TRIM indicator pointer is not at GND position, go to Task 11-3.17.		

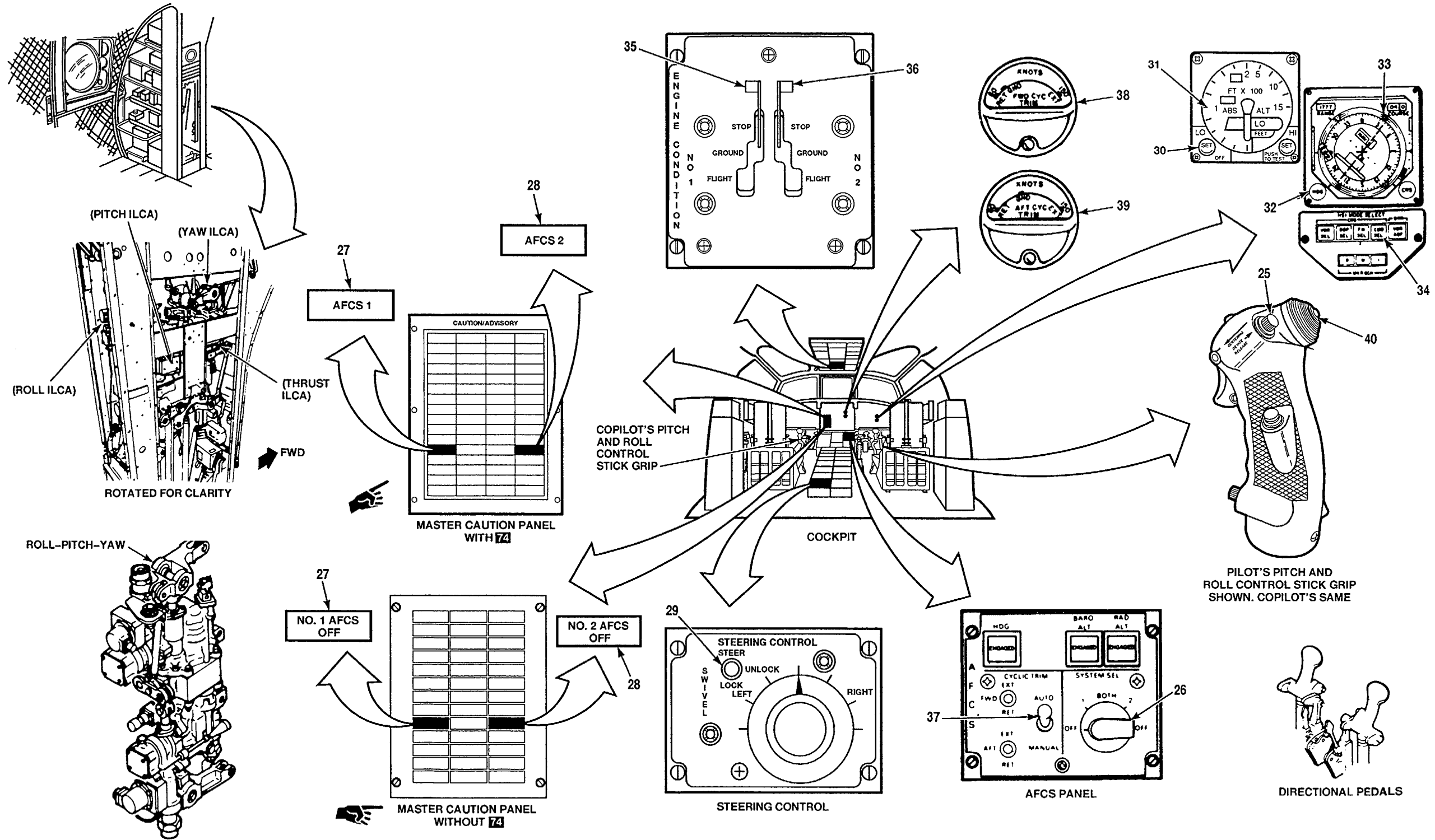

A65457

TASK	RESULT
<p>WARNING Keep head, hands, and other body parts clear of flight controls, especially those in flight controls closet. AFCS BITE automatically causes actuator and controls motion. Severe injury can occur.</p>	
17. Set NO. 1 ENGINE CONDITION lever (35) to FLIGHT.	
18. Press and release NO. 1 AFCS computer BITE switch (41).	Computer digital test counter (42) shall remain blank. BITE switch (41) shall not flash. If counter does not remain blank or BITE switch flashes, go to task 11-3.25.
19. Set NO. 1 ENDING CONDITION lever (35) to STOP. Set NO. 2 ENGINE CONDITION lever (36) to FLIGHT. Repeat step 18 then go to step 20.	
20. Set NO. 2 ENGINE CONDITION lever (36) to STOP.	
21. Press and release BITE switch (41).	Computer counter (42) shall step and display from 1 through 3 and stop at 3. BITE switch (41) shall light and flash while display is stepping and then glow steadily after display indicates 3. If display is blank and BITE switch does not light, go to task 11-3.26. If counter steps to and stops at 3 but BITE switch does not light, replace NO. 1 AFCS computer. If BITE switch lights but display stops at 1 or 2, repeat operational check task 11-3.3. If same result occurs, replace NO. 1 AFCS computer.
22. Press and release BITE switch (41).	Computer counter (42) shall step and display from 4 through 95 (end of test) and go blank. BITE switch shall flash while display is stepping. If BITE switch lights steadily, and counter stops at an intermediate number, record that number. Push BITE switch to continue test. Go to table 11-3.1 to determine maintenance action. At end of test, counter shall go blank and BITE switch light shall go out. If BITE switch lamp flashes at step 95, the PUSH TO TEST switch on the Pilots or Copilots radar altimeter indicator must be actuated within 20 seconds in order to avoid a false failure indication.

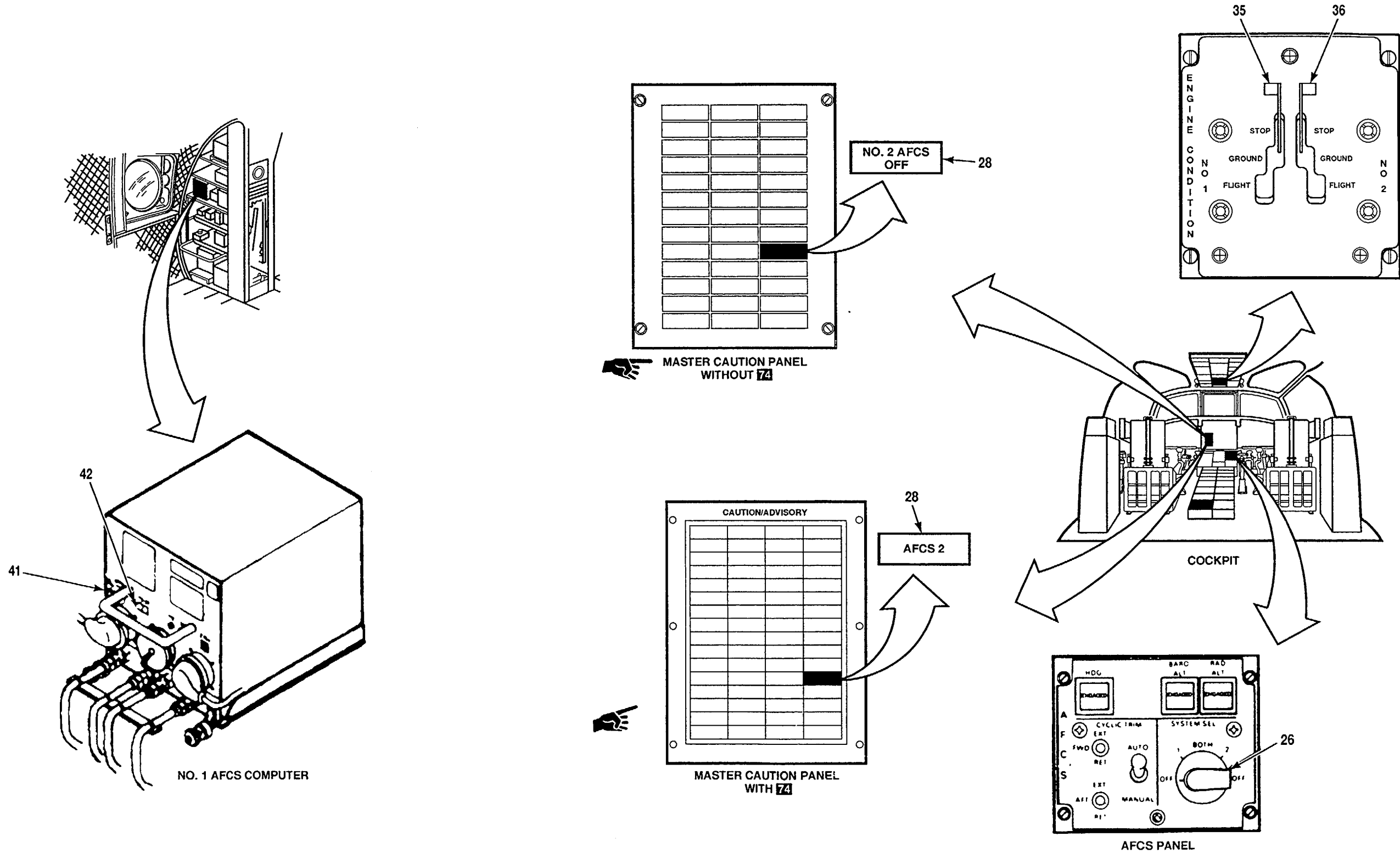

A65458

11-3.3 AFCS OPERATIONAL CHECK (Continued)

11-3.3

TASK	RESULT	TASK	RESULT
CHECK NO. 2 AFCS			
23. Set SYSTEM SEL switch (26) to BOTH, pause for 10 seconds then set it to OFF through position 2.	NO. 1 AFCS OFF and NO. 2 AFCS OFF (Without 74) AFCS 1 and 2 (With 74) capsules (27 and 28) shall come on. If NO. 1 AFCS OFF (Without 74) AFCS 1 (With 74) (capsule 27) is out, go to Task 11-3.13. If NO. 2 AFCS OFF (Without 74) AFCS 2 (With 74) capsule (28) is out, go to Task 11-3.14.	31. Set SYSTEM SEL switch (26) to 2.	NO. 2 AFCS OFF (Without 74) AFCS 2 (With 74) capsule (28) shall go out. No large Integrated Lower Control Actuator (ILCA) engagement transients (hardovers) shall occur. If capsule (28) is still on, go to Task 11-3.27. If large ILCA engagement transients (hardovers) occur, go to Task 11-3.28 for pitch transient, Task 11-3.29 for roll transient, or Task 11-3.30 for yaw transient.
24. Set SWIVEL switch (26) to LOCK.		32. Move pilot's directional pedals right, then left. Return pedals to center.	No. 2 yaw ILCA output shaft shall extend with pedal right and retract with pedal left. If No. 2 yaw ILCA output shaft does not extend or retract, go to Task 11-3.31.
25. Turn pilot's radar altimeter LO SET knob (30) until lo set index (31) is at 100.	Radar altimeter OFF flag shall go out of view. Digital readout shall indicate 0 to 5 feet after 1 minute warmup. If OFF flag is still in view or digital indication is not 0 to 5 feet, refer to TM 11-1520-240-20 for troubleshooting information.	33. Move pilot's pitch and roll control stick right, then left. Return grip to center.	No. 2 roll ILCA output shaft shall extend with stick right and retract with stick left. If No. 2 roll ILCA output shaft does not extend or retract, go to Task 11-3.32.
26. Turn pilot's HSI HDG knob (32) until heading cursor (33) is 30° degrees clockwise from aircraft heading.		34. Momentarily set pilot's pitch and roll trim switch (40) right then left. Release switch.	No. 2 roll ILCA output shaft shall extend when switch (40) is right and retract when switch is left. If No. 2 roll ILCA output shaft does not extend or retract, go to Task 11-3.33.
27. Press and release pilot's CMD SEL switch (34).	CMD SEL caption shall come on. If it does not, refer to TM 11-1520-240-20.	34.1 Momentarily set copilot's pitch and roll trim switch (40) right then left. Release switch.	No. 2 roll ILCA output shaft shall extend when switch (40) is right and retract when switch is left. If No. 2 roll ILCA output shaft does not extend or retract, go to Task 11-3.33.
28. Check that both ENGINE CONDITION levers (35 and 36) are at STOP.	Set them to STOP if required.	35. Press and hold pilot's CENTERING DEVICE RELEASE switch (25). Center pilot's pitch and roll control stick and directional pedals. Release CENTERING DEVICE RELEASE switch.	
29. Check that CYCLIC TRIM AUTO MANUAL switch (37) is at AUTO.	Set switch to AUTO if required.		
30. Check FWD and AFT CYC TRIM indicators (38 and 39).	Pointers on both indicators (38 and 39) shall be in GND position. If both pointers are not in GND position, go to Task 11-3.15. If FWD CYC TRIM indicator pointer is not at GND position, go to Task 11-3.16. If AFT CYC TRIM indicator pointer is not at GND position, go to Task 11-3.17.		

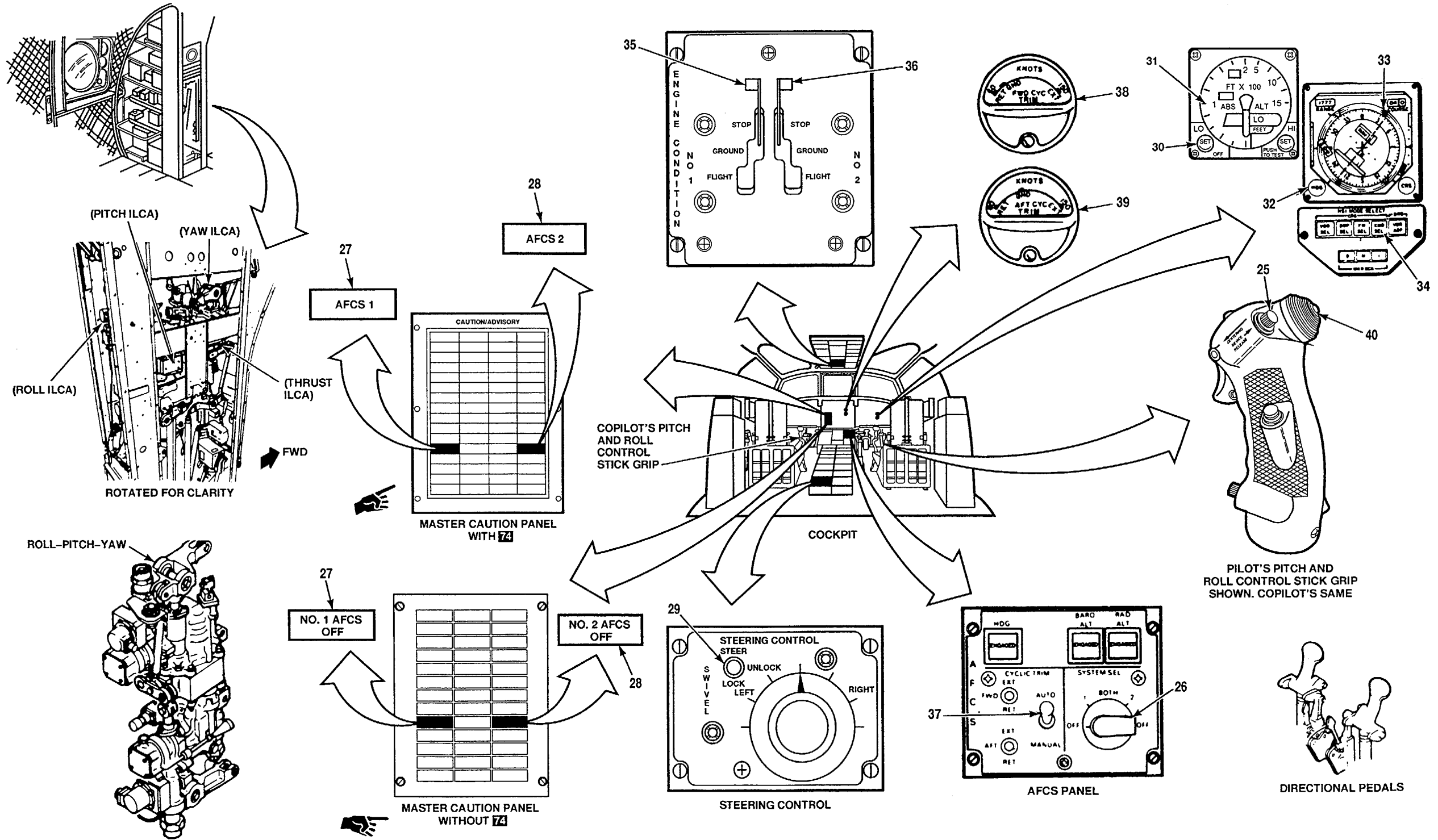

A65457

TASK	RESULT
<p><u>WARNING</u> Keep head, hands, and other body parts clear of flight controls, especially those in flight controls closet. AFCS BITE automatically causes actuator and controls motion. Severe injury can occur.</p>	
<p>36. Set NO. 1 ENGINE CONDITION lever (35) to FLIGHT.</p>	
<p>37. Press and release NO. 2 AFCS computer BITE switch (43).</p>	<p>Computer digital test counter (44) shall remain blank. BITE switch (43) shall not flash. If counter does not remain blank or BITE switch flashes, go to task 11-3.25.</p>
<p>38. Set NO. 1 ENGINE CONDITION lever (35) to STOP. Set NO. 2 ENGINE CONDITION lever (36) to FLIGHT. Repeat step 37 then go to step 39.</p>	
<p>39. Set NO. 2 ENGINE CONDITION lever (36) to STOP.</p>	
<p>40. Press and release BITE switch (43).</p>	<p>Computer counter (44) shall step and display from 1 through 3 and stop at 3. BITE switch (41) shall light and flash while display is stopping and then glow steadily after display indicates 3. If display is blank and BITE switch does not light, go to task 11-3.34. If counter steps to and stops at 3 but BITE switch does not light, replace NO. 2 AFCS computer. If BITE switch lights but display stops at 1 or 2, repeat operational check task 11-3.2. If same result occurs, replace NO. 2 AFCS computer.</p>
<p>41. Press and release BITE switch (43).</p>	<p>Computer counter (44) shall step and display from 4 through 95 (end of test) and go blank. BITE switch shall flash while display is stepping. If BITE switch lights steadily, and counter stops at an intermediate number, record that number. Push BITE switch to continue test. Go to table 11-3.1 to determine maintenance action. At end of test, counter shall go blank and BITE switch light shall go out. If BITE switch lamp flashes at step 95, the PUSH TO TEST switch on the Pilots or Copilots radar altimeter indicator must be actuated within 20 seconds in order to avoid a false failure indication.</p>

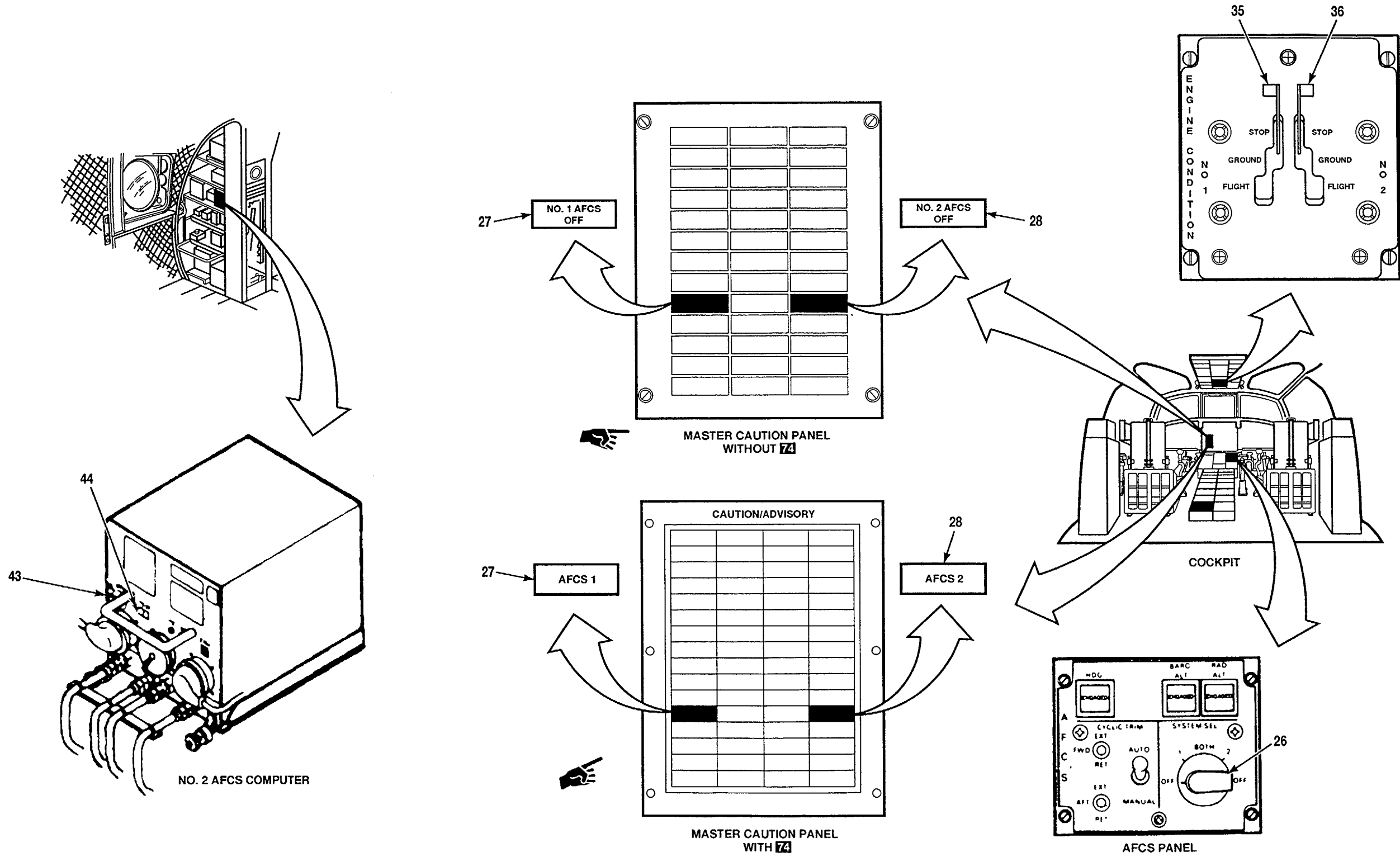

A65459

TASK	RESULT
CHECK LONGITUDINAL CYCLIC TRIM ACTUATOR CONTROL	
42. Set CYCLIC TRIM AUTO MANUAL switch (37) to MANUAL.	
43. Set and hold FWD switch (45) to EXT.	FWD CYC TRIM indicator (38) pointer shall move from GND to EXT position. If it does not, go to task 11-3.35.
44. Set and hold FWD switch (45) to RET.	FWD CYC TRIM indicator (38) pointer shall move from EXT to RET position. If it does not, go to task 11-3.35.
45. Release FWD switch (45). Set and hold AFT switch (46) to EXT.	AFT CYC TRIM indicator (39) pointer shall move from GND to EXT position. If it does not, go to task 11 -3.36.
46. Set and hold AFT switch (46) to RET.	AFT CYC TRIM indicator (39) pointer shall move from EXT to RET position. If it does not, go to task 11-3.36.
47. Release AFT switch (46).	
48. Set CYCLIC TRIM AUTO MANUAL switch (37) to AUTO.	Pointers on FWD and AFT CYC TRIM indicators (38 and 39) shall move to GND positions.

CHECK HDG, RAD ALT, AND BARO ALT SWITCHES

49. Check that SYSTEM SEL switch (26) is at BOTH.	If not, set it to BOTH.
50. Press and hold HDG switch (47).	HDG switch (47) ENGAGED caption shall come on. If not, go to task 11-3-37.
51. Release HDG switch (47).	
52. Press and release RAD ALT switch (48).	RAD ALT switch (48) ENGAGED caption shall come on and stay on. If not, go to task 11 -3.38.

TASK	RESULT
53. Press and release BARO ALT switch (49).	RAD ALT switch (48) ENGAGED caption shall go out. BARO ALT switch (49) ENGAGED caption shall come on. If not, go to task 11-3.38.
54. Set SYSTEM SEL switch to position 1, then to OFF.	BARO ALT switch (49) ENGAGED caption shall go out. If not, replace AFCS control panel.
CHECK LONGITUDINAL COCKPIT CONTROL DRIVER ACTUATOR	
55. Set and hold pilot's pitch and roll trim switch (40) forward.	Pitch and roll control sticks shall move forward. If not, go to task 1 1-3-39.
56. Set and hold pilot's pitch and roll trim switch (40) aft.	Pitch and roll control sticks shall move aft. If not, go to task 11 -3.39.
57. Repeat steps 55 and 56 using copilot's pitch and roll trim switch (40).	

NOTE
 If a problem with AFCS occurred during flight and could not be verified by the AFCS operational check, refer to table 11-3.2 to locate trouble symptom task number.

TABLE 11-3.1

BITE TEST NUMBER	TASK NO. OR MAINTENANCE ACTION
4, 5, 7, 8, 10-17, 19-47, 49-69.....	Replace computer
75-84, 88, 90-94, 96-127.	
6, 9, 18.....	11-3.40
48.....	11 -3.41
70-74	11-3.42
85, 86.....	11-3.43 or 11-3.44
87	11-3.45
89	11-3.46 or 11-3.47
95.....	11-3.48

TASK

RESULT

TABLE 11-3.2

TROUBLE SYMPTOM	Task Number	
	NO. 1 AFCS	NO. 2 AFCS
Longitudinal Axis:		
AFCS Pitch Stabilization Erratic or Oscillatory	11-3.49	11-3.49
AFCS Pitch Attitude/Airspeed Hold Weak or Inoperative	11-3.50	11-3.51
AFCS Longitudinal Control Position Out of Trim	11-3.52	11-3.52
Lateral Axis:		
AFCS Roll Stabilization Erratic/Oscillatory or Roll Attitude Hold Weak or Inoperative	11-3.53	11-3.53
Heading Select Mode Response Weak or Inoperative (Both Systems)	11-3.54	11-3.54
AFCS Heading Select Mode Response Weak or Inoperative	11-3.55	11-3.56
Directional Axis:		
YAW Stability Erratic/Oscillatory	11-3.57	11-3.58
AFCS Heading Hold Weak or Inoperative	11-3.59	11-3.59
AFCS Lateral Stick Only Turns Not Coordinated	11-3.60	11-3.60
Collective Axis:		
Barometric Altitude Hold Inoperative or Response Erratic (Radar Altitude Hold Okay)	11-3.61	
Radar Altitude Hold Inoperative or Response Erratic (Barometric Altitude Hold Okay)	11-3.62	
Barometric and Radar Altitude Hold Inoperative or Response Erratic	11-3.63	

FOLLOW-ON MAINTENANCE:

- TM 55-1520-240-23:
- Hydraulic Power Off
- Electrical Power Off
- Battery Disconnected
- Flight Controls Closet Acoustic Blanket Installed.

- Electronic Compartment Acoustic Blanket Installed
- Pylon Left Work Platform Closed.
- Forward Left Work Platform Closed.

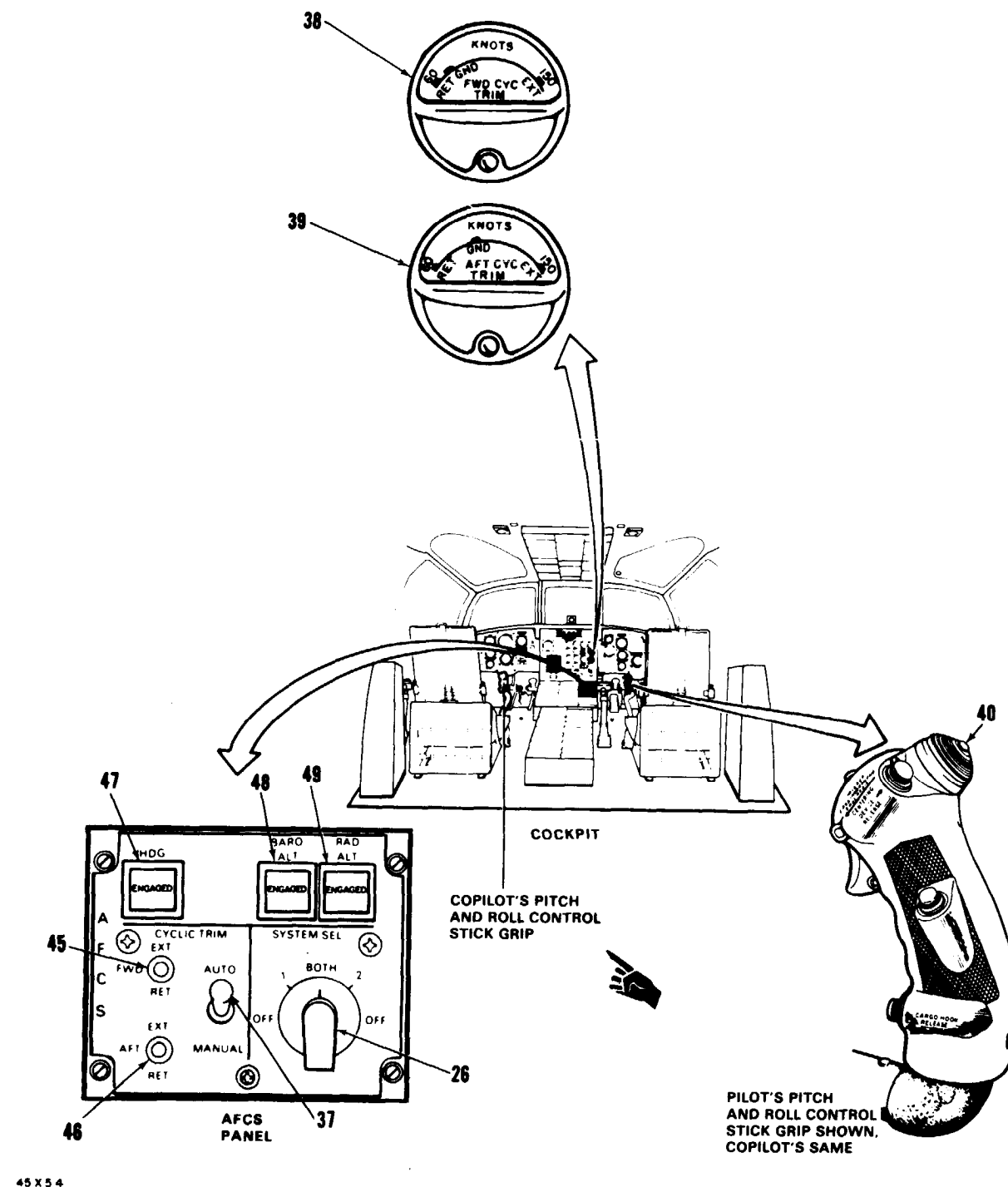

45 X 5 4

9 0 9

END OF TASK

11-3.4 NO. 1 AFCS AC CIRCUIT BREAKER WILL NOT STAY CLOSED

FAULT ISOLATION PROCEDURE

INITIAL SETUP

Personnel Required:
35K20 Avionic Mechanic

Applicable Configurations:

All

References:
TM 55-1520-240-23

Tools:

Electrical Repairer's Tool Kit,
NSN 5180-00-323-4915
Multimeter

Equipment Condition:
TM 55-1520-240-23
Battery Disconnected
Electrical Power Off
Hydraulic Power Off

Materials:

None

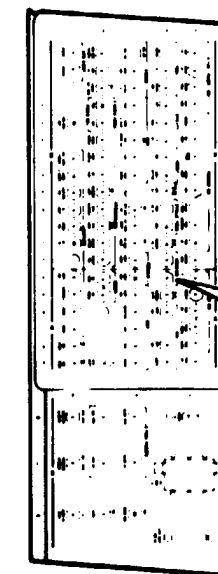
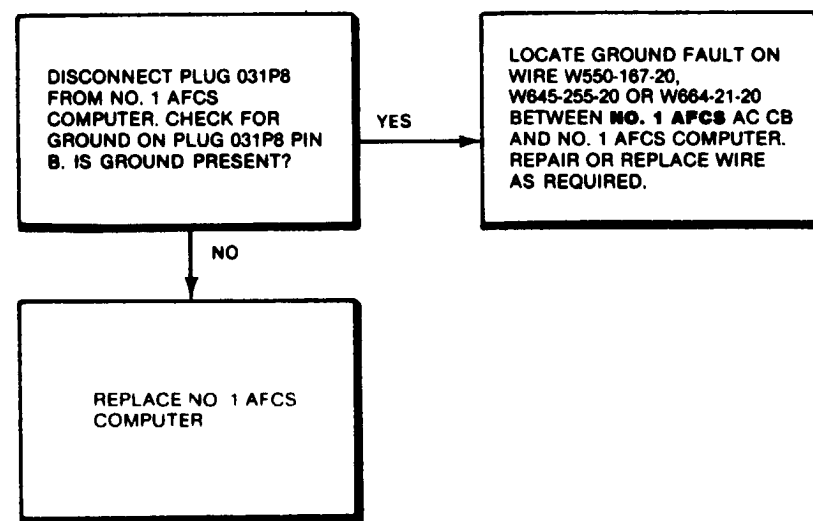
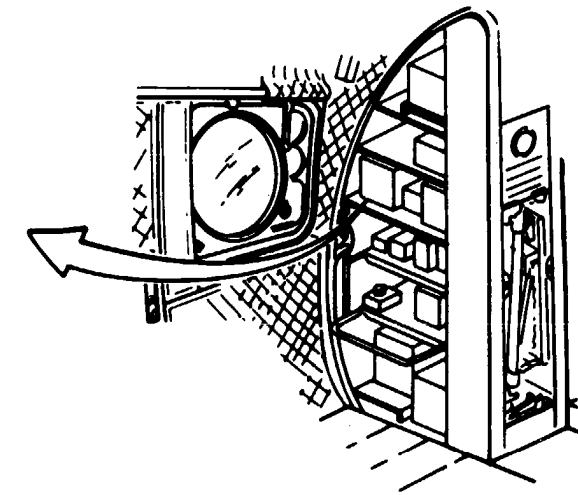
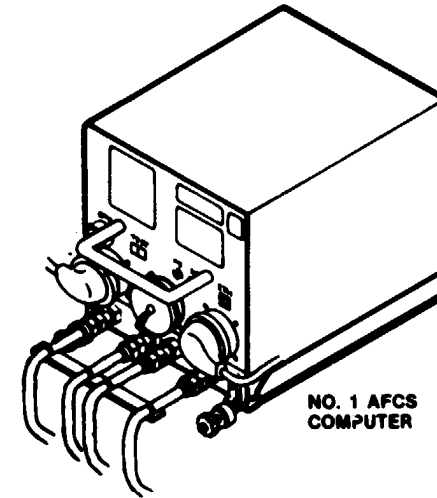

NO. 1 POWER DISTRIBUTION PANEL (PDP) VIEW LOOKING AFT

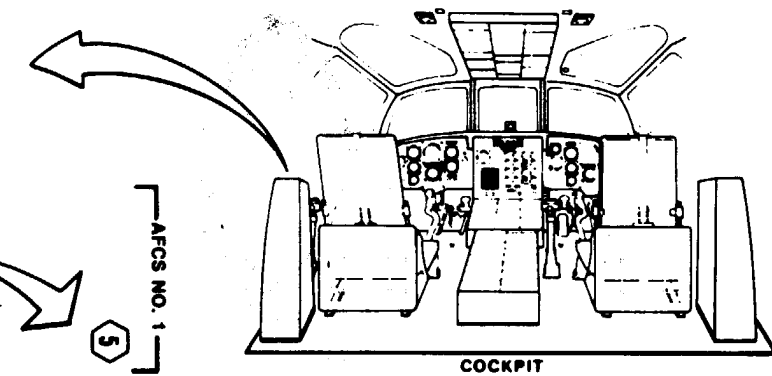

11-3.5 CLTV DRIVER ACTR AC CIRCUIT BREAKER WILL NOT STAY CLOSED

FAULT ISOLATION PROCEDURE

INITIAL SETUP

Applicable Configurations:

All

Tools:

Electrical Repairer's Tool Kit,
NSN 5180-00-323-4915
Multimeter

Materials:

None

Personnel Required:

35K10 Avionic Mechanic
35K20 Avionic Mechanic

References:

TM 55-1520-240-23

Equipment Condition:

TM 55-1520-240-23
Battery Disconnected
Electrical Power Off
Hydraulic Power Off

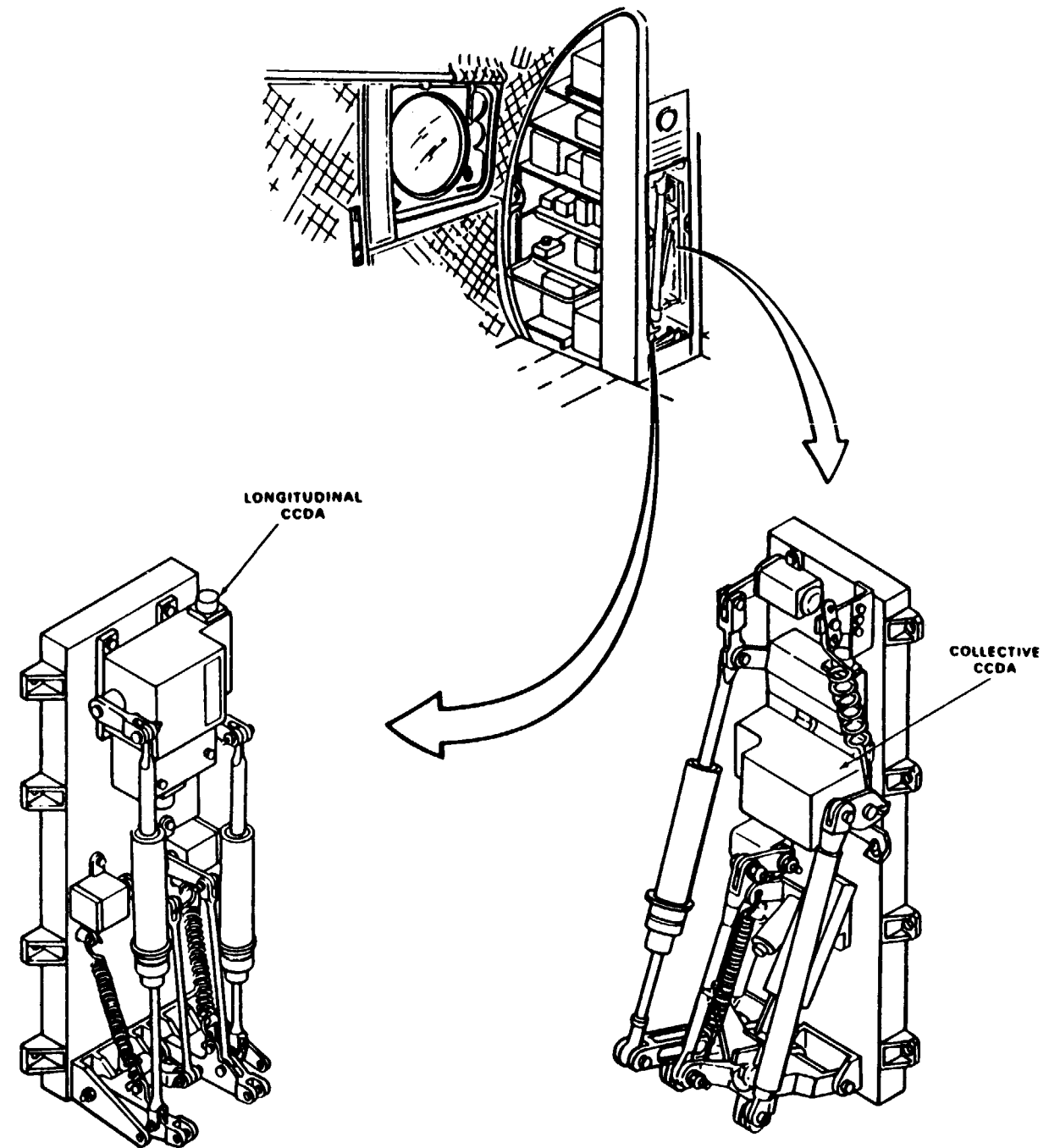
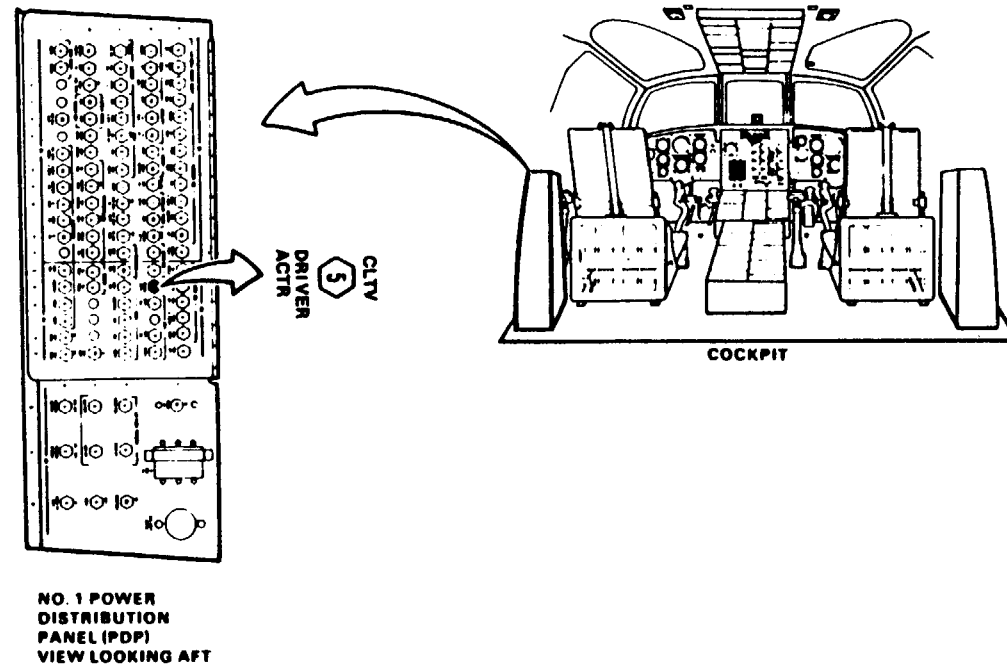

11-3.5 CLTV DRIVER ACTR AC CIRCUIT BREAKER WILL NOT STAY CLOSED (Continued)

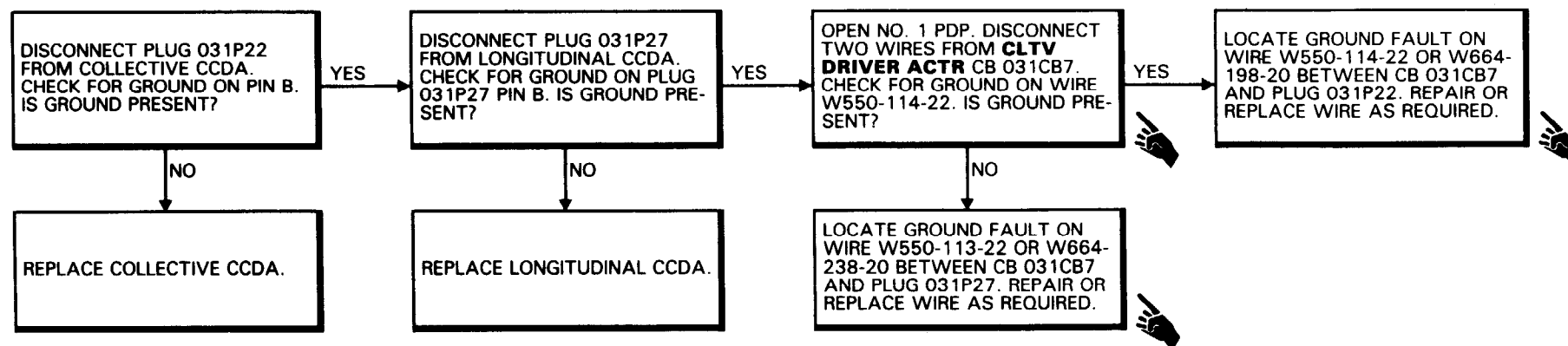

11-3.6 AFCS NO. 1 DC CIRCUIT BREAKER WILL NOT STAY CLOSED

FAULT ISOLATION PROCEDURE

INITIAL SETUP

Applicable Configurations:

All

Tools:

Electrical Repairer's Tool Kit,
NSN 5180-00-323-4915
Multimeter

Materials:

None

Personnel Required:

35K10 Avionic Mechanic
35K20 Avionic Mechanic

References:

TM 55-1520-240-23

Equipment Condition:

TM 55-1520-240-23
Battery Disconnected
Electrical Power Off
Hydraulic Power Off

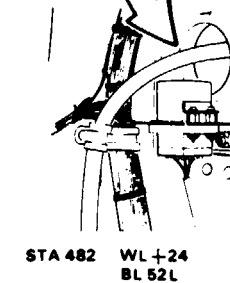
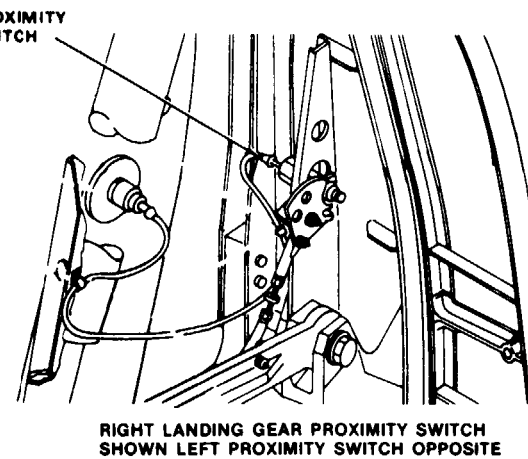
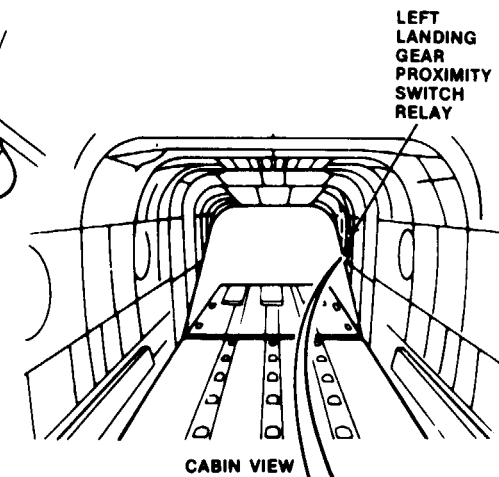
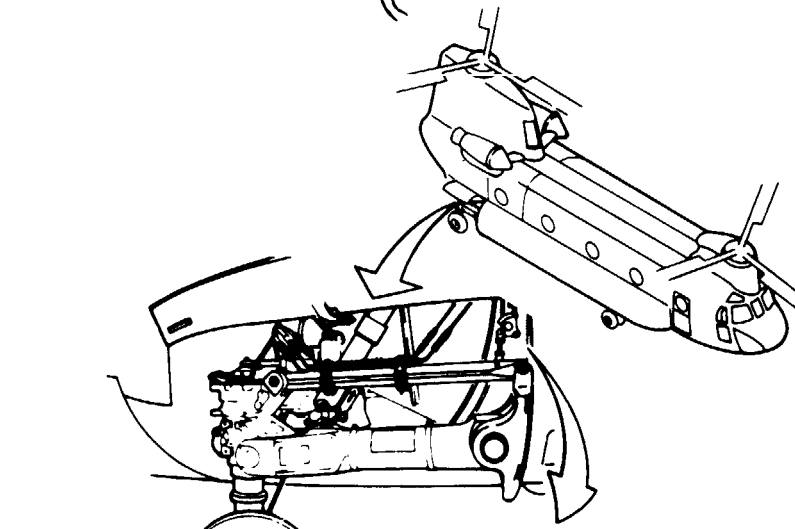
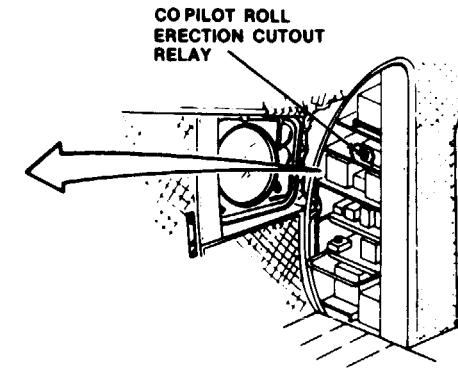
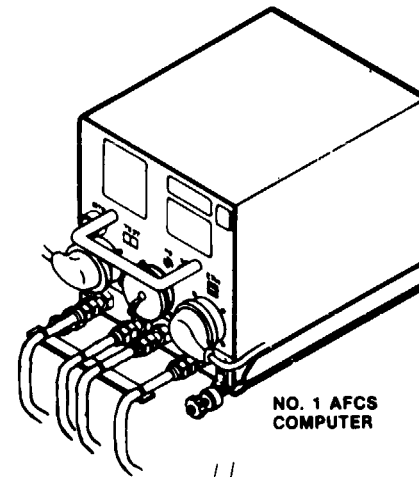
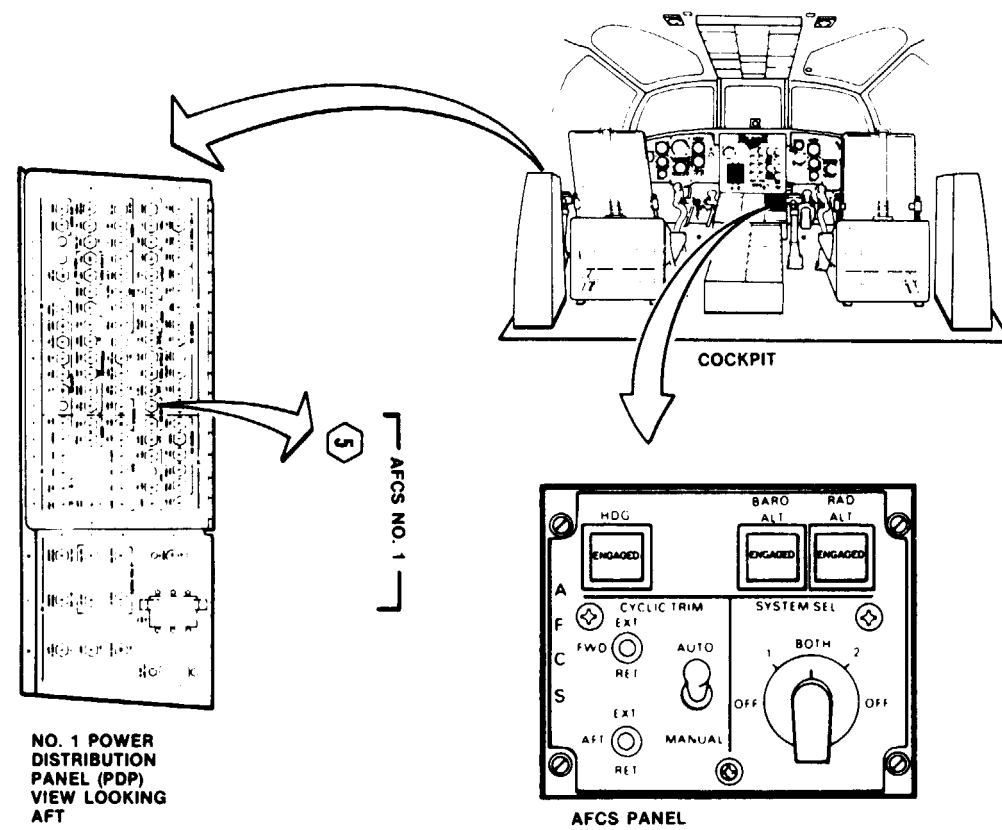

90x54

D145-11923-SPA

GO TO NEXT PAGE

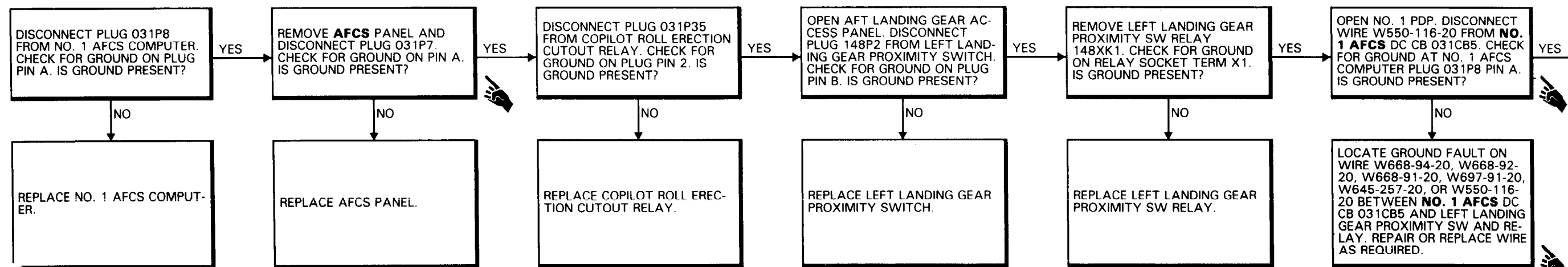

11-3.6 AFCS NO. 1 DC CIRCUIT BREAKER WILL NOT STAY CLOSED
(Continued)

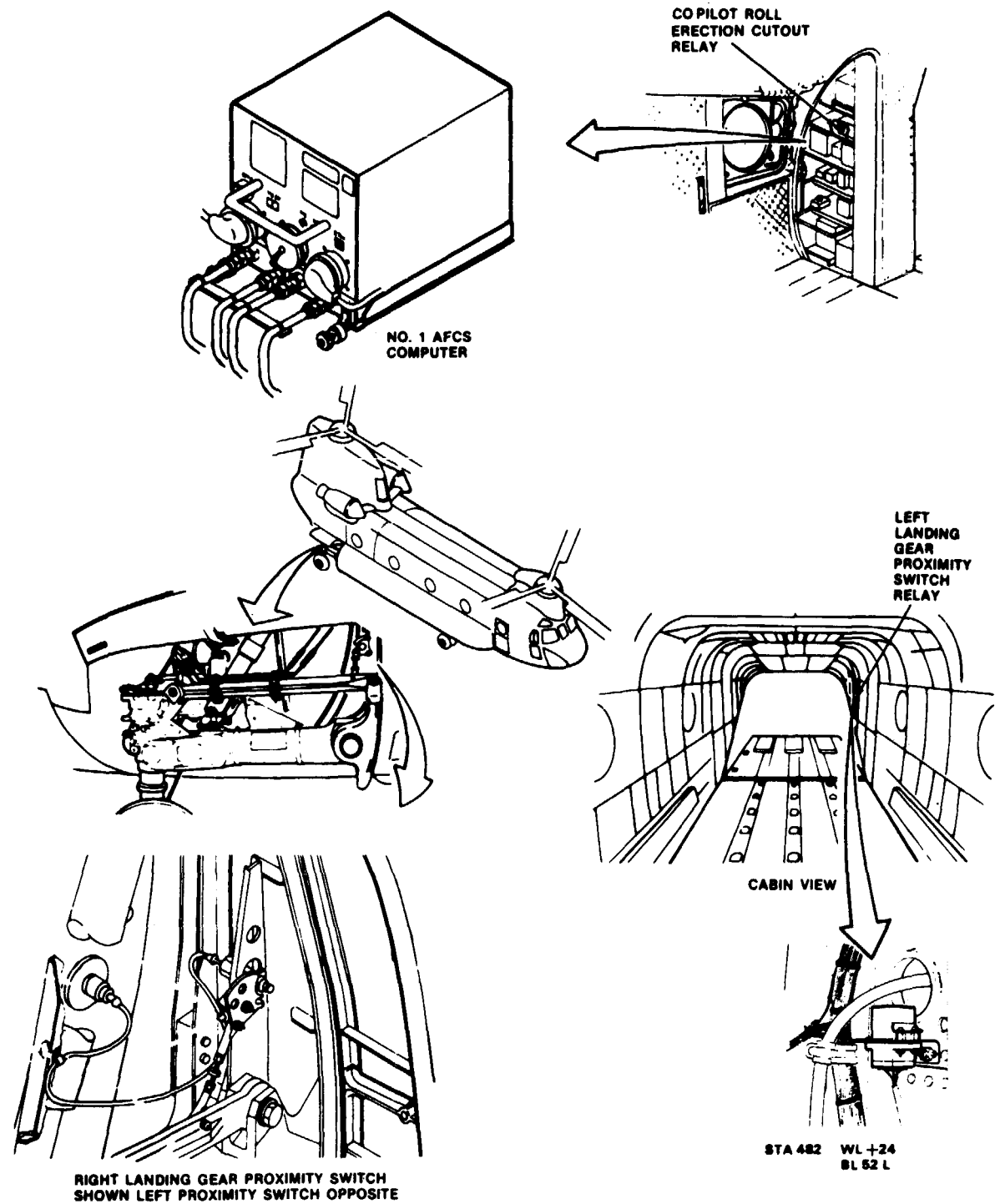
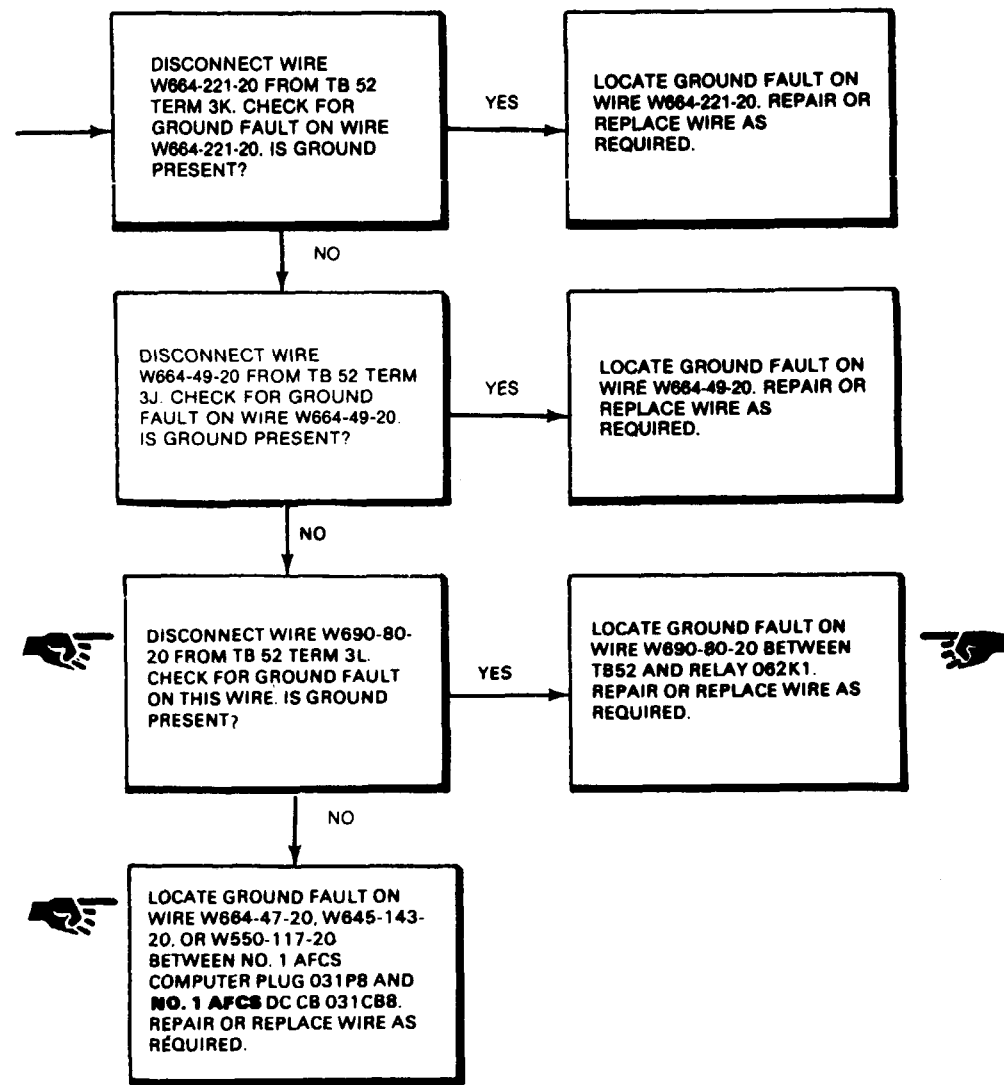

D145-11924-5PA

END OF TASK

11-3.7 CLTV DRIVER ACTR CIRCUIT BREAKER WILL NOT STAY CLOSED

11-3.7

FAULT ISOLATION PROCEDURE

INITIAL SETUP

Applicable Configurations:

All

Tools:

Electrical Repairer's Tool Kit,
NSN 5180-00-323-4915
Multimeter

Materials:

None

Personnel Required:

35K10 Avionic Mechanic
35K20 Avionic Mechanic

References:

TM 55-1520-240-23

Equipment Condition:

TM 55-1520-240-23
Battery Disconnected
Electrical Power Off
Hydraulic Power Off

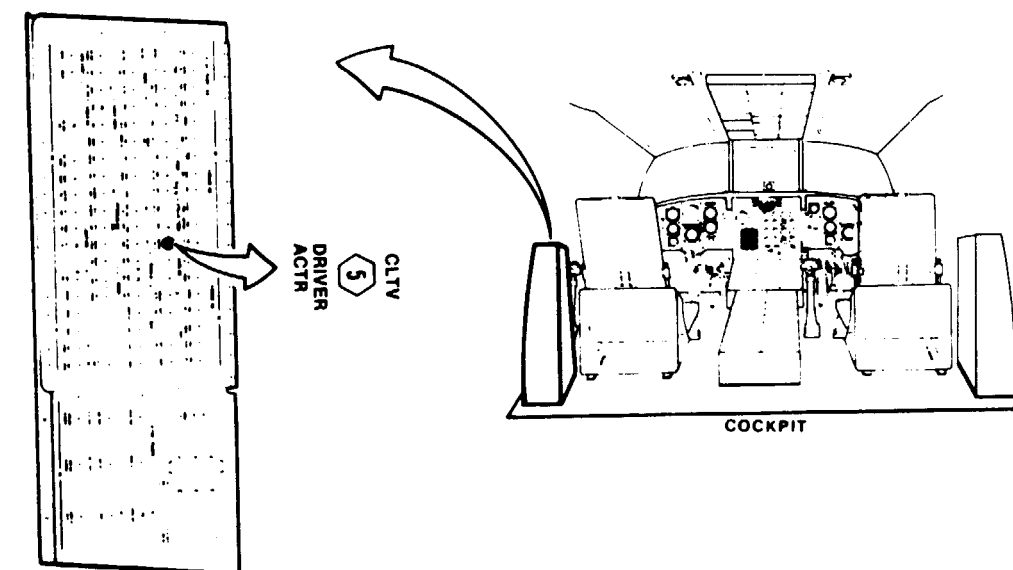
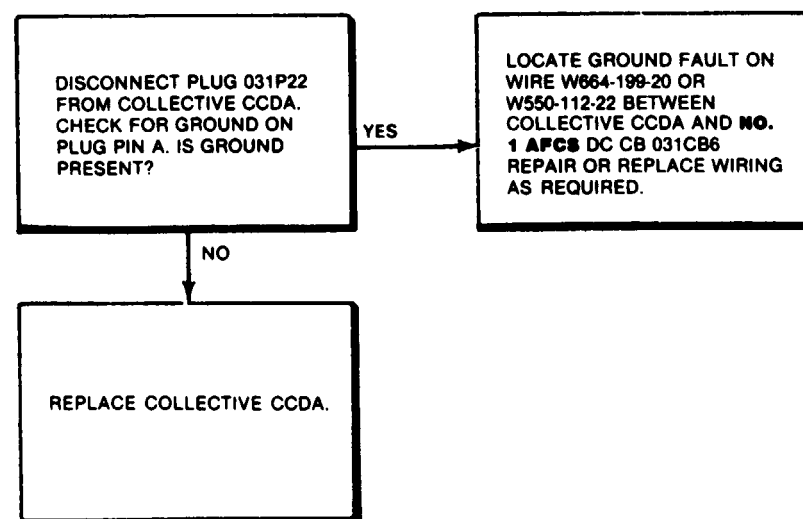
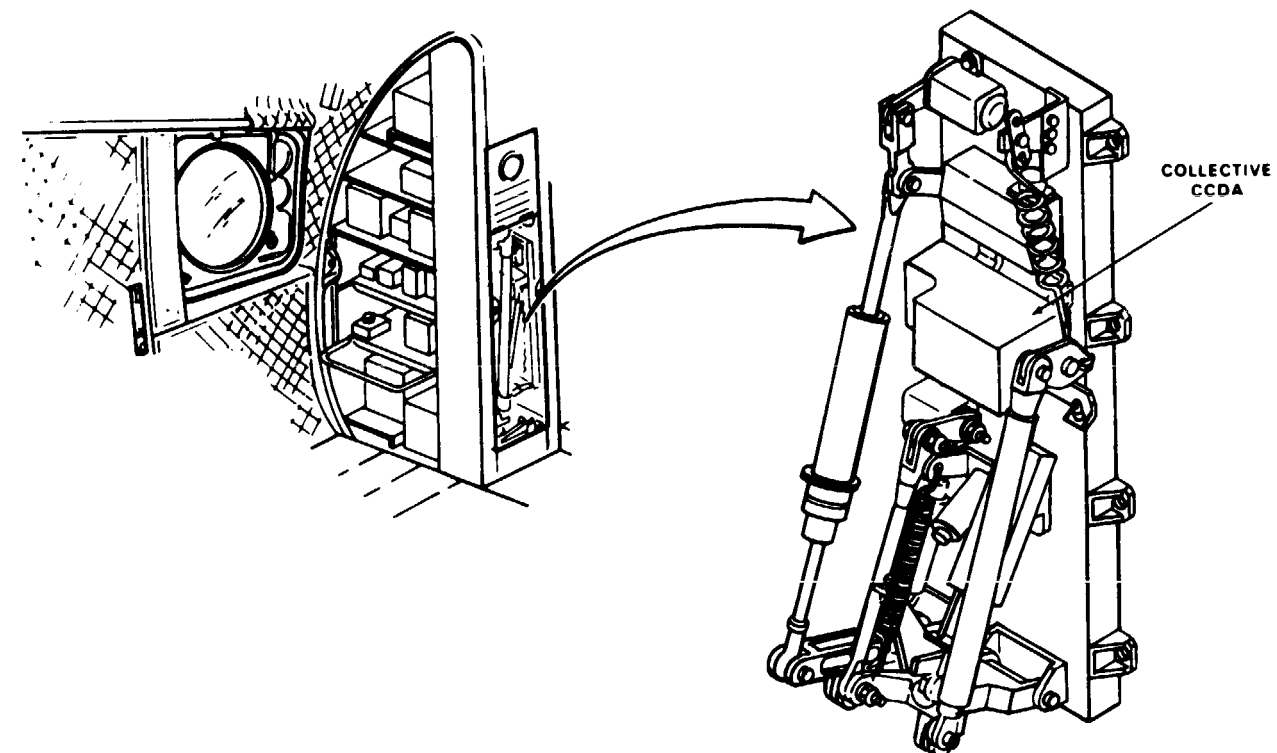

NO 1 POWER DISTRIBUTION PANEL (PDP) VIEW LOOKING AFT

FAULT ISOLATION PROCEDURE

INITIAL SETUP

Personnel Required:

Avionic Mechanic (2)

References:

TM 55-1520-240-23

Equipment Condition:

TM 55-1520-240-23:

Battery Disconnected

Electrical Power Off

Hydraulic Power Off

Applicable Configurations:

All

Tools:

Electrical Repairer's Tool Kit,

NSN 5180-00-323-4915

Multimeter

Materials:

None

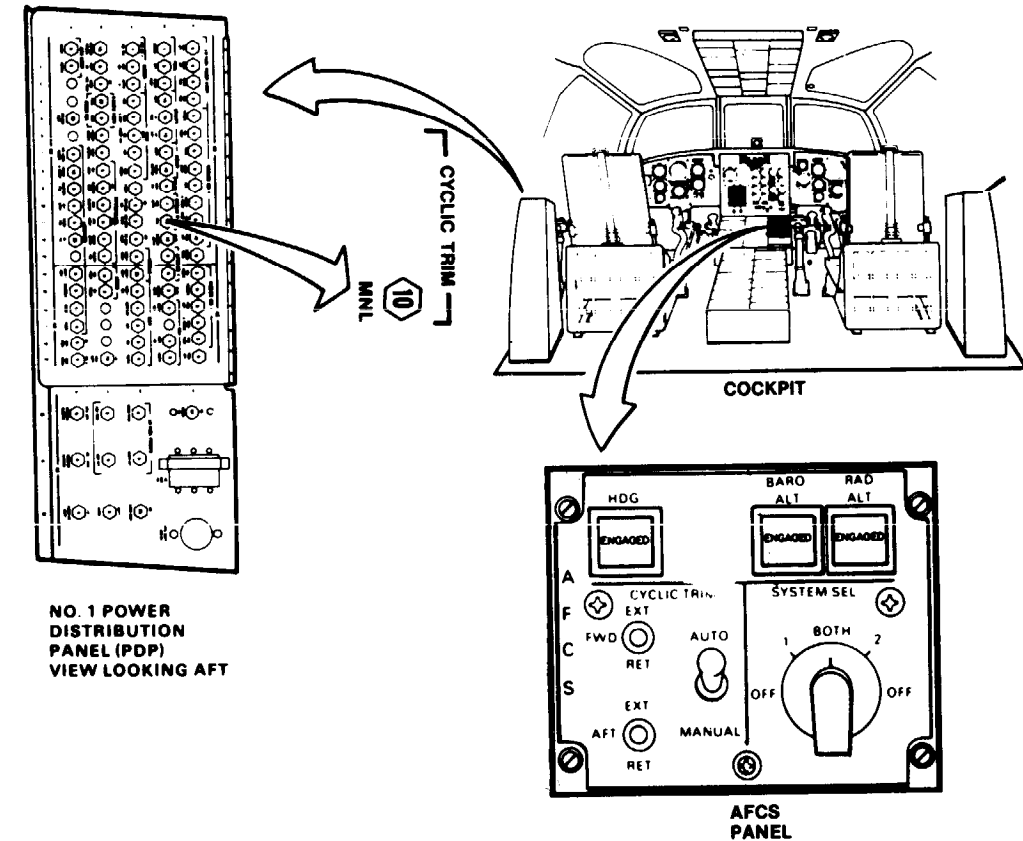
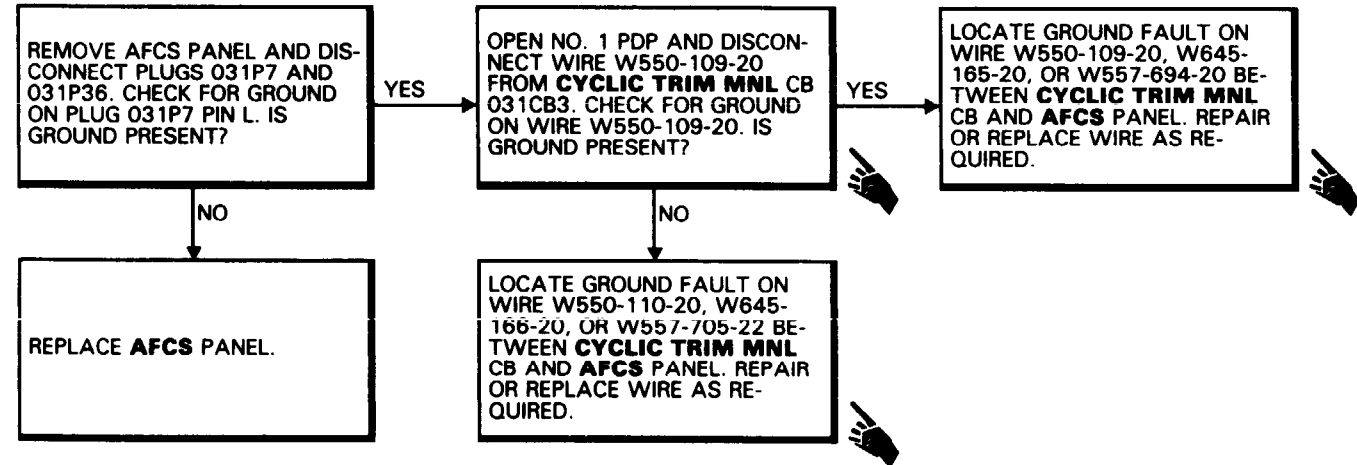

45 x 54

DI48-11911-3PA

11-3.9 CYCLIC TRIM FWD ACTR CIRCUIT BREAKER WILL NOT STAY CLOSED

FAULT ISOLATION PROCEDURE

INITIAL SETUP

Applicable Configurations:

All

Tools:

Electrical Repairer's Tool Kit,
NSN 5180-00-323-4915
Multimeter

Materials:

None

Personnel Required:

35K10 Avionic Mechanic
35K20 Avionic Mechanic

References:

TM 55-1520-240-23

Equipment Condition:

TM 55-1520-240-23
Battery Disconnected
Electrical Power Off
Hydraulic Power Off

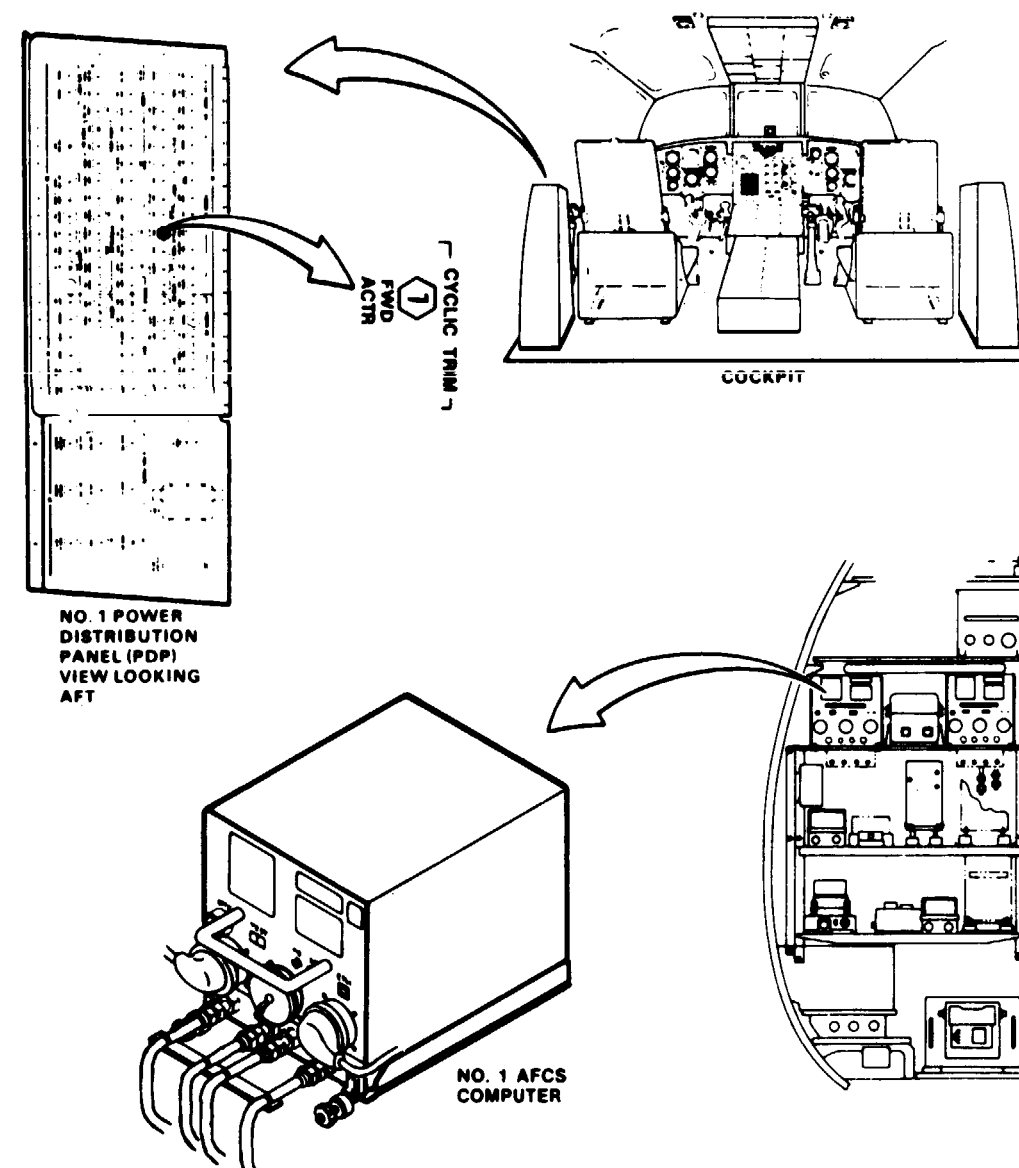
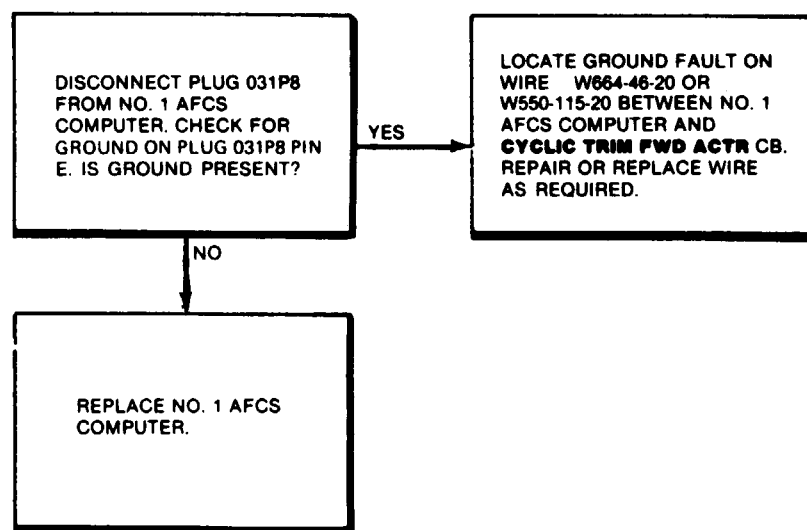

48 X84

FAULT ISOLATION PROCEDURE

INITIAL SETUP

Applicable Configurations:

All

Tools:

Electrical Repairer Tool Kit,
NSN 5180-00-323-4915
Multimeter

Materials:

None

Personnel Required:

Avionic Mechanic

References:

TM 55-1520-240-23

Equipment Condition:

TM 55-1520-240-23:
Battery Disconnected
Electrical Power Off
Hydraulic Power Off

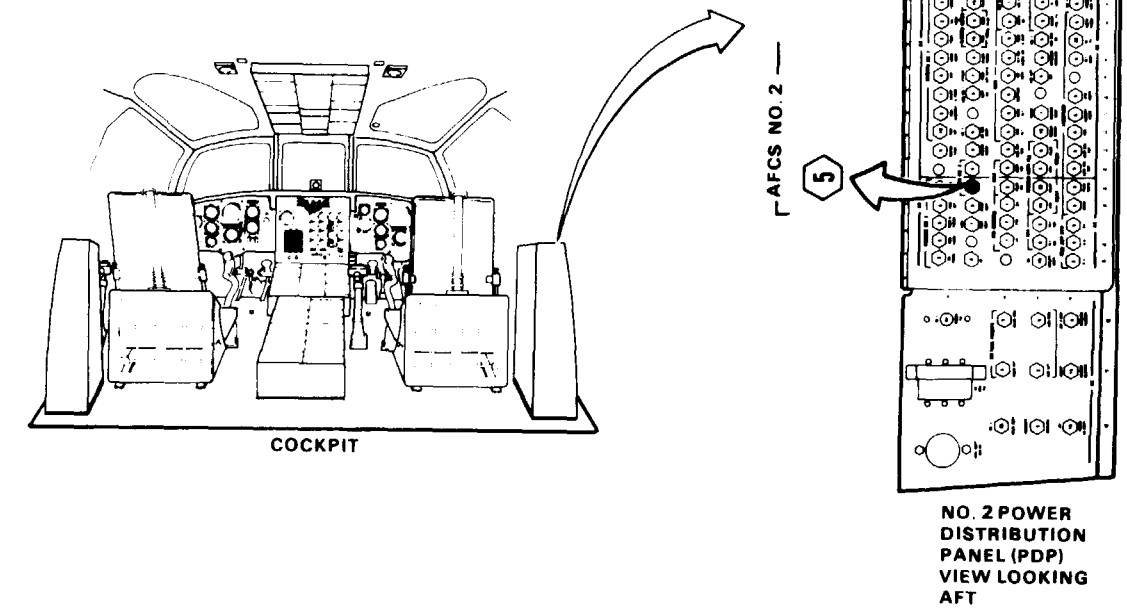
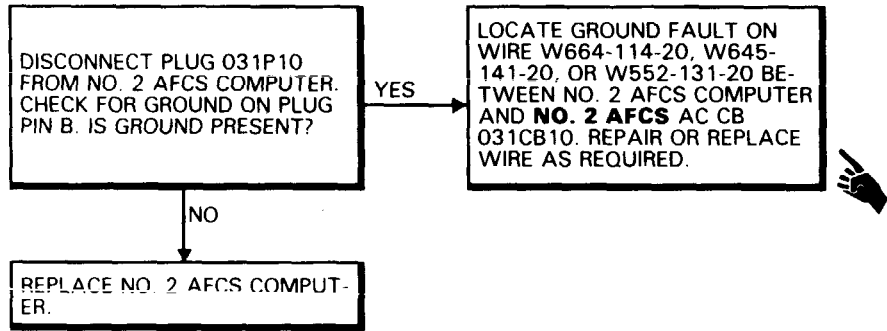
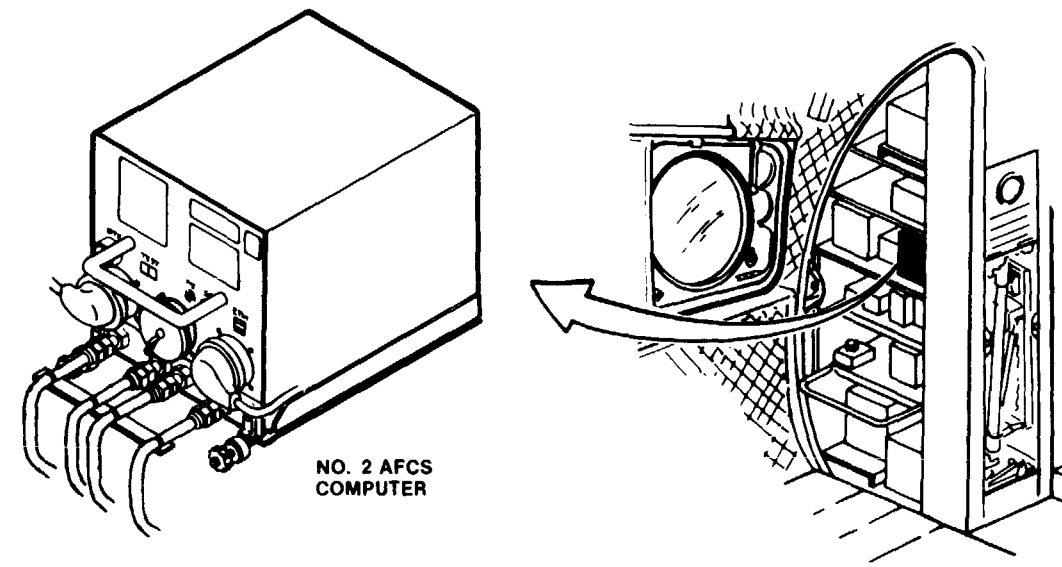

FAULT ISOLATION PROCEDURE

INITIAL SETUP

Applicable Configurations:

All

Tools:

Electrical Repairer's Tool Kit,
NSN 5180-00-323-4915
Multimeter

Materials:

None

Personnel Required:

35K10 Avionic Mechanic
35K20 Avionic Mechanic

References:

TM 55-1520-240-23

Equipment Condition:

TM 55-1520-240-23
Battery Disconnected
Electrical Power Off
Hydraulic Power Off

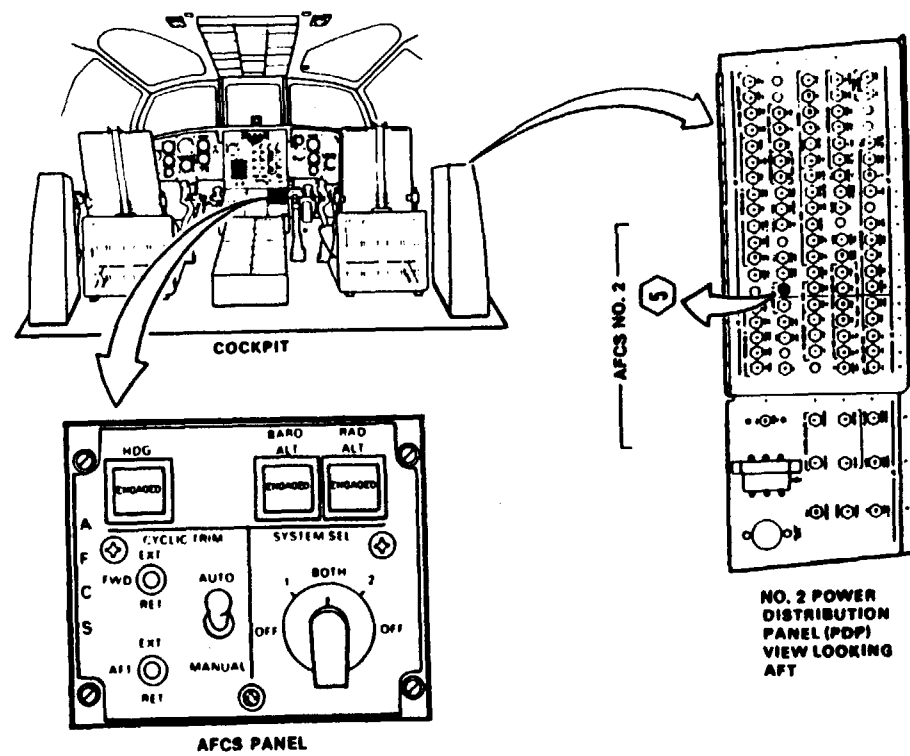
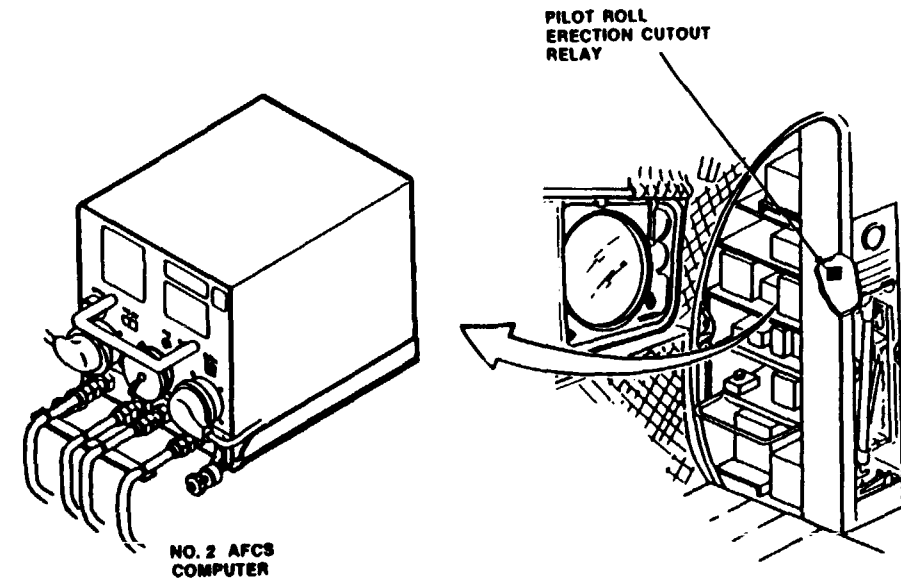

90X94

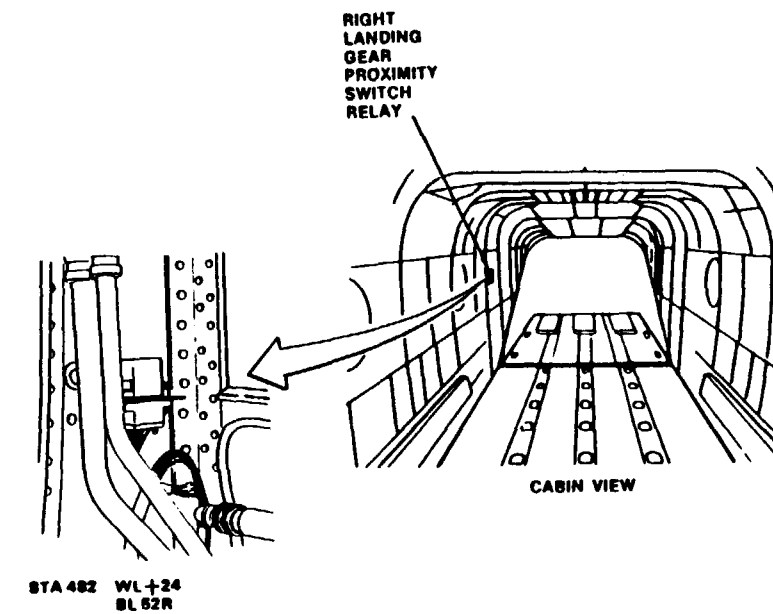
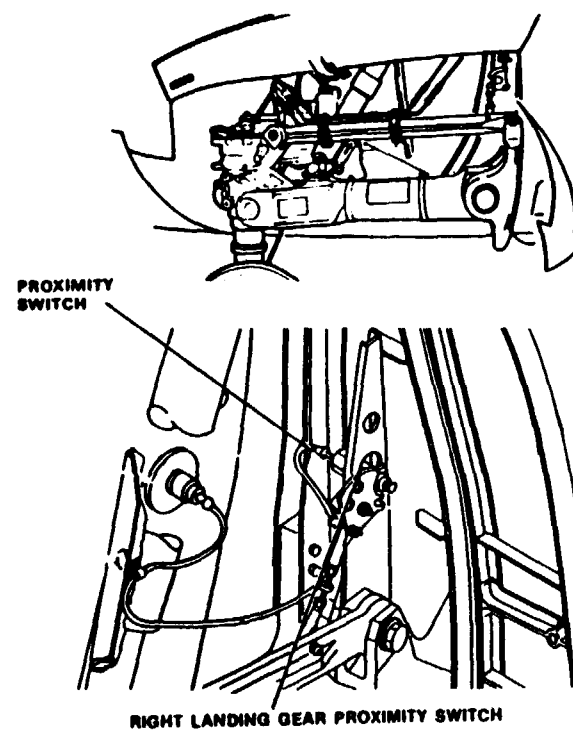

D145-11915-11915-5PA

Page 11-71 is a blank page.

GO TO NEXT PAGE

11-3.11 AFCS NO. 2 DC CIRCUIT BREAKER WILL NOT STAY CLOSED (Continued)

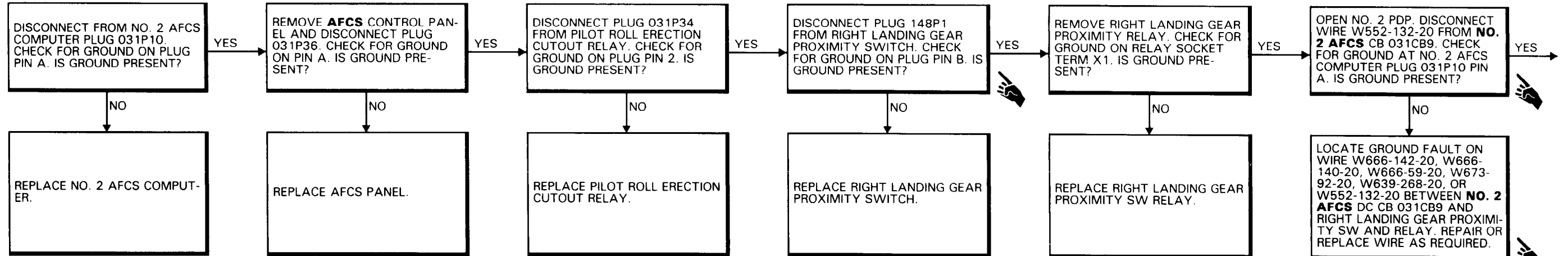

11-3.11 AFCS NO. 2 DC CIRCUIT BREAKER WILL NOT STAY CLOSED (Continued)

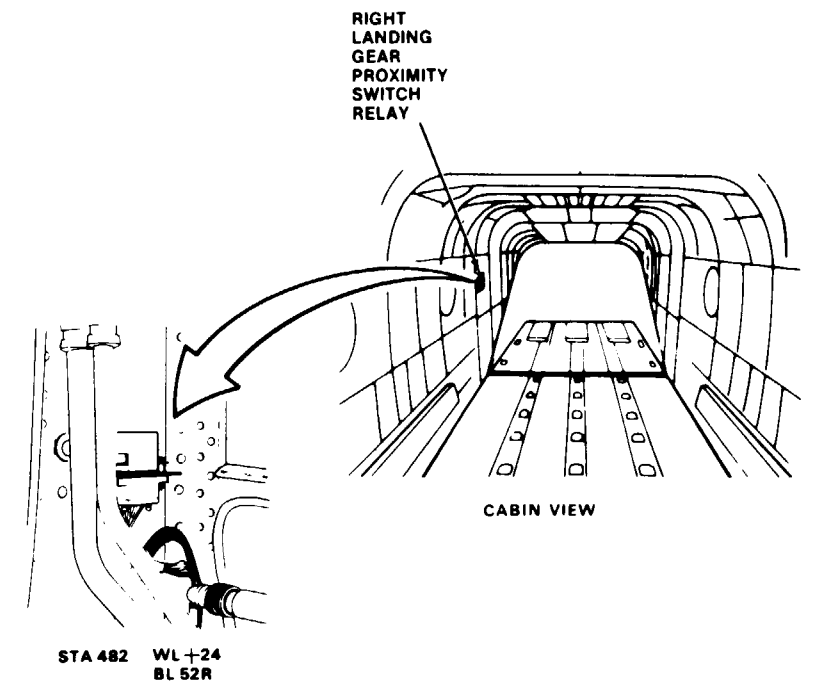
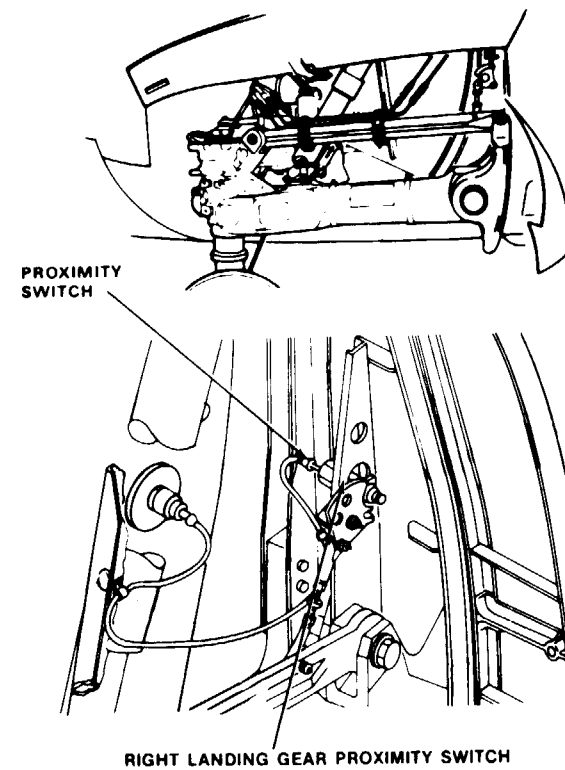
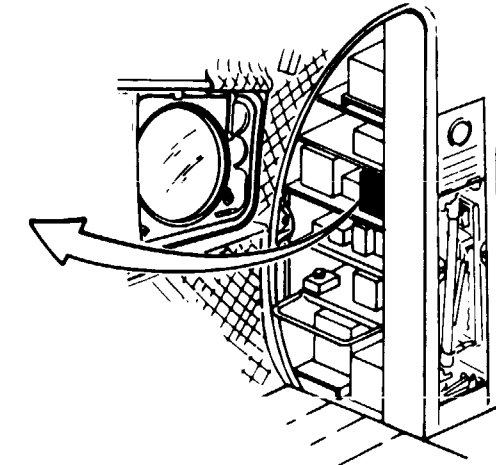
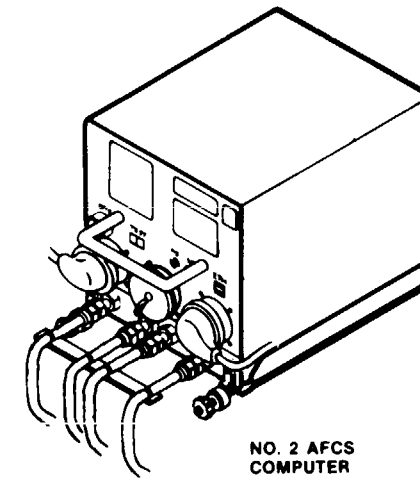
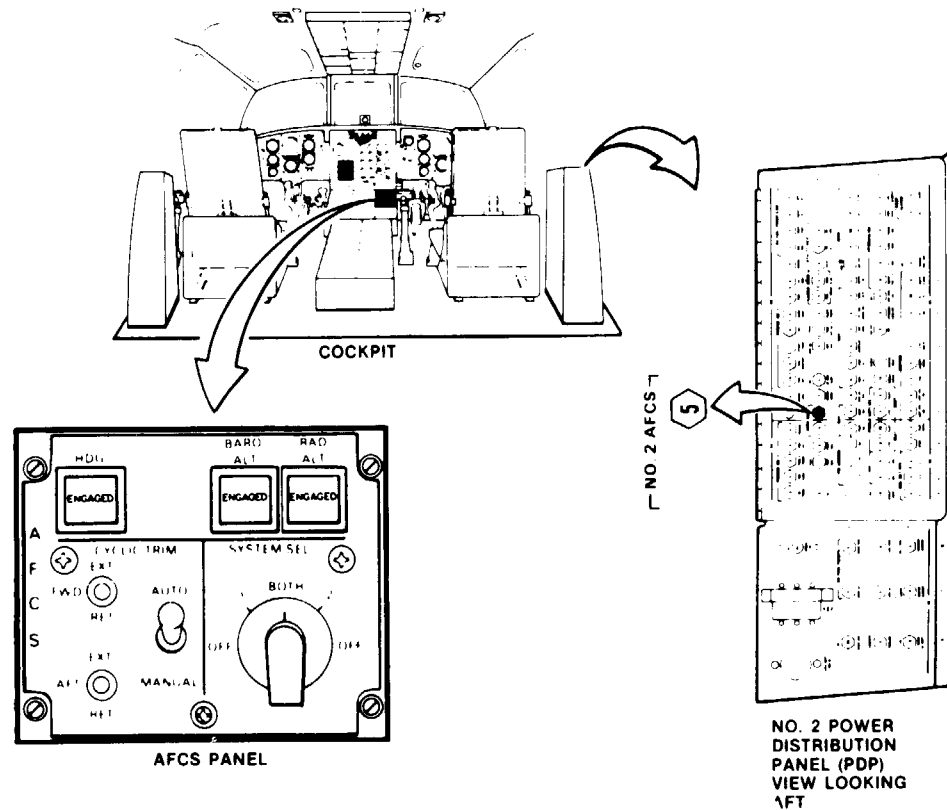
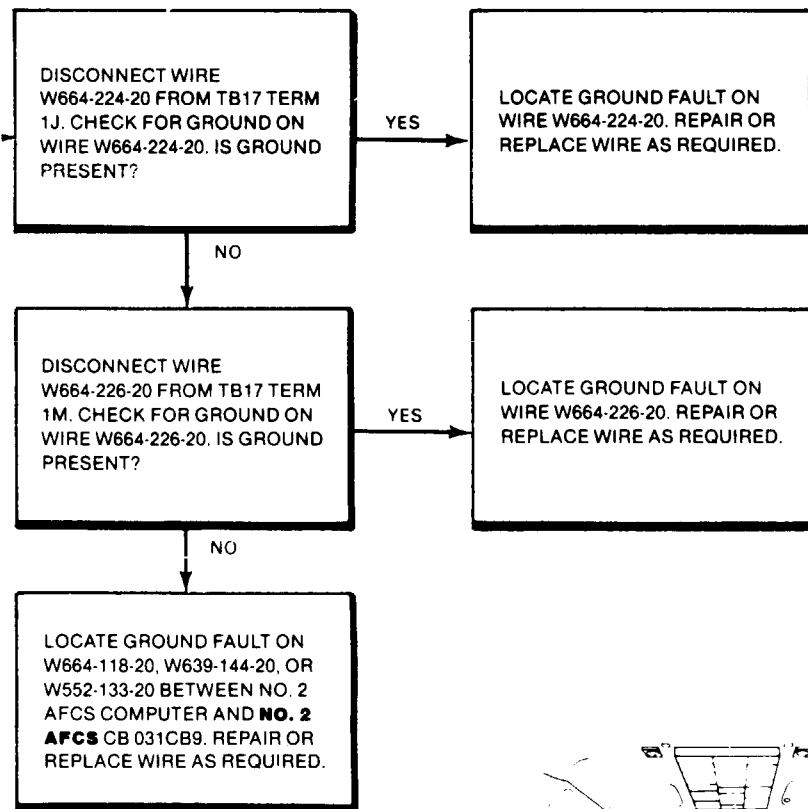

90X54

D145-11916-SPA

11-3.12 CYCLIC TRIM AFT ACTUATOR CIRCUIT BREAKER WILL NOT STAY CLOSED

11-3.12

FAULT ISOLATION PROCEDURE

INITIAL SETUP

Applicable Configurations:
All

Tools:
Electrical Repairer's Tool Kit,
NSN 5180-00-323-4915
Multimeter

Materials:
None

Personnel Required:
Avionic Mechanic (2)

References:
TM 55-1520-240-23

Equipment Condition:
TM 55-1520-240-23:
Battery Disconnected
Electrical Power Off
Hydraulic Power Off

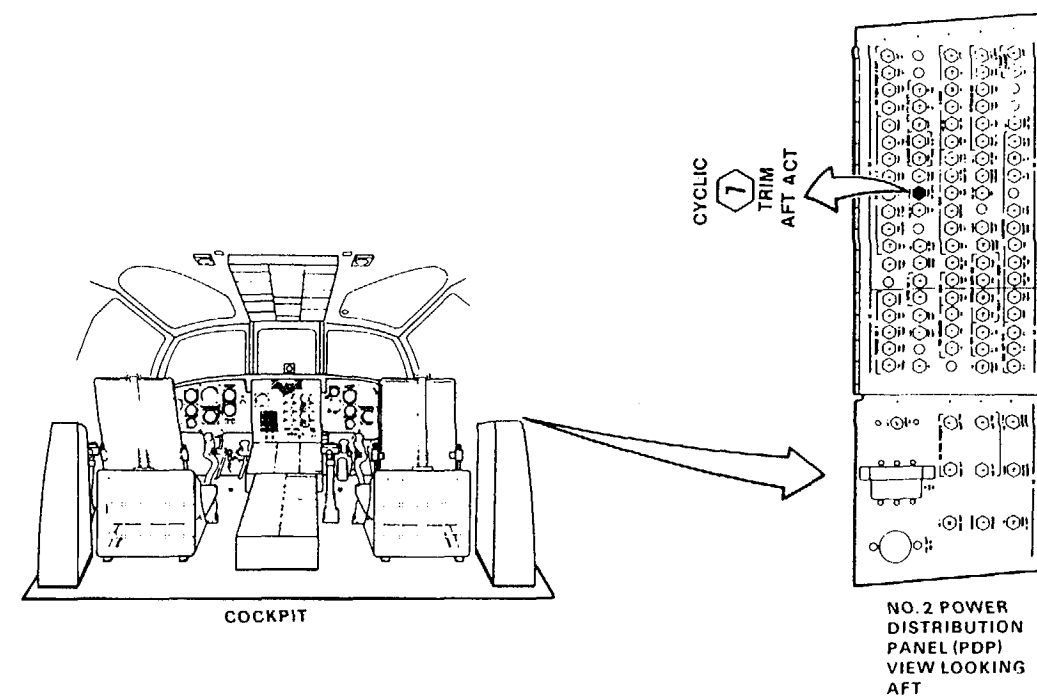
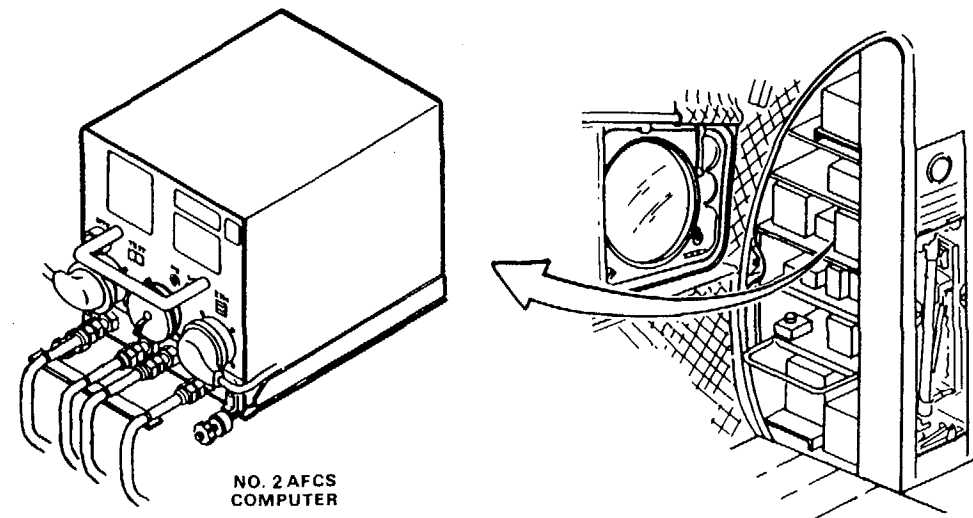
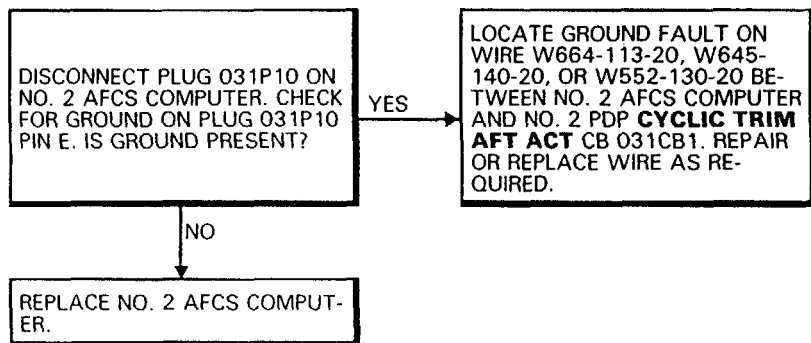

11-3.13 NO. 1 AFCS OFF (WITHOUT 74) OR AFCS 1 (WITH 74) CAPSULE IS OUT WITH SYSTEM SELECTED OFF

FAULT ISOLATION PROCEDURE

INITIAL SETUP

Applicable Configurations:

All

Tools:

Electrical Repairer's Tool Kit,
NSN 5180-00-323-4915
Multimeter

Materials:

None

Personnel Required:
Avionic Mechanic (2)

References:
TM 55-1520-240-23

Equipment Condition:
TM 55-1520-240-23:
Battery Connected
Electrical Power On
Hydraulic Power Off

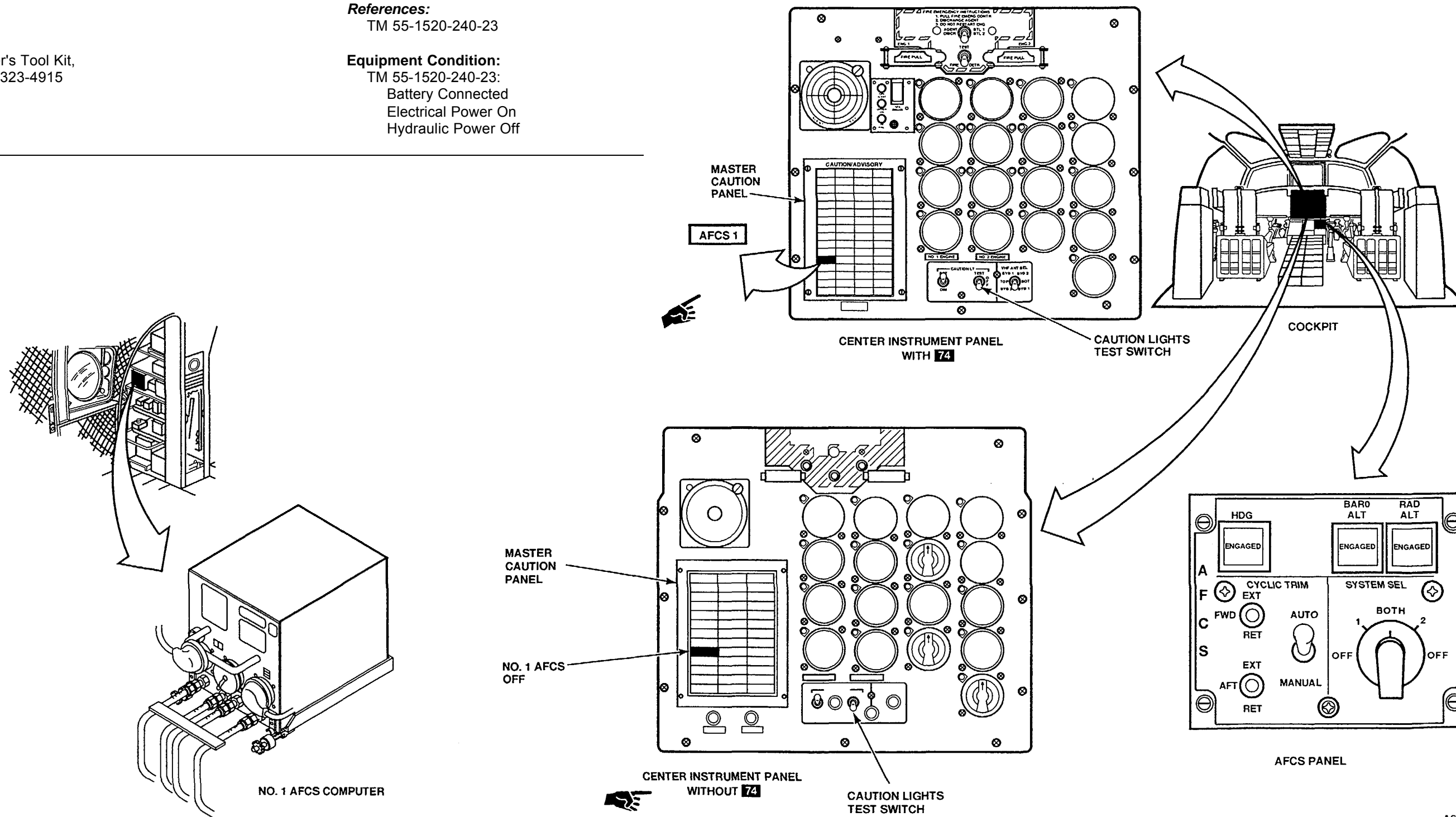

A65460

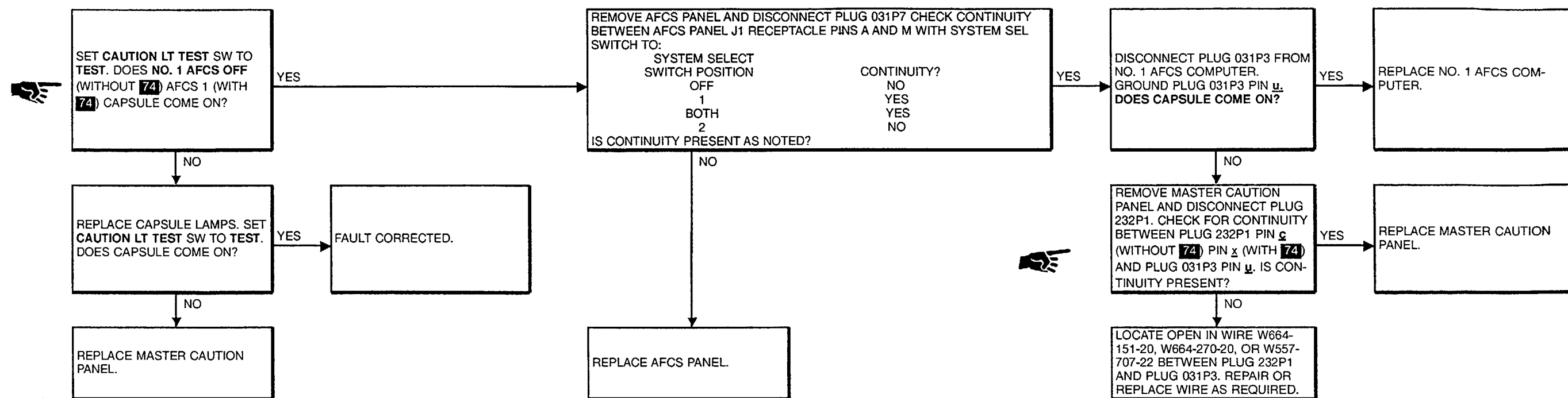

FAULT ISOLATION PROCEDURE

INITIAL SETUP

Applicable Configurations:

All

Tools:

Electrical Repairer's Tool Kit,
NSN 5180-00-323-4915

Multimeter

Materials:

None

Personnel Required:

Avionic Mechanic (2)

References:

TM 55-1520-240-23

Equipment Condition:

TM 55-1520-240-23

Battery Connected

Electrical Power On

Hydraulic Power On

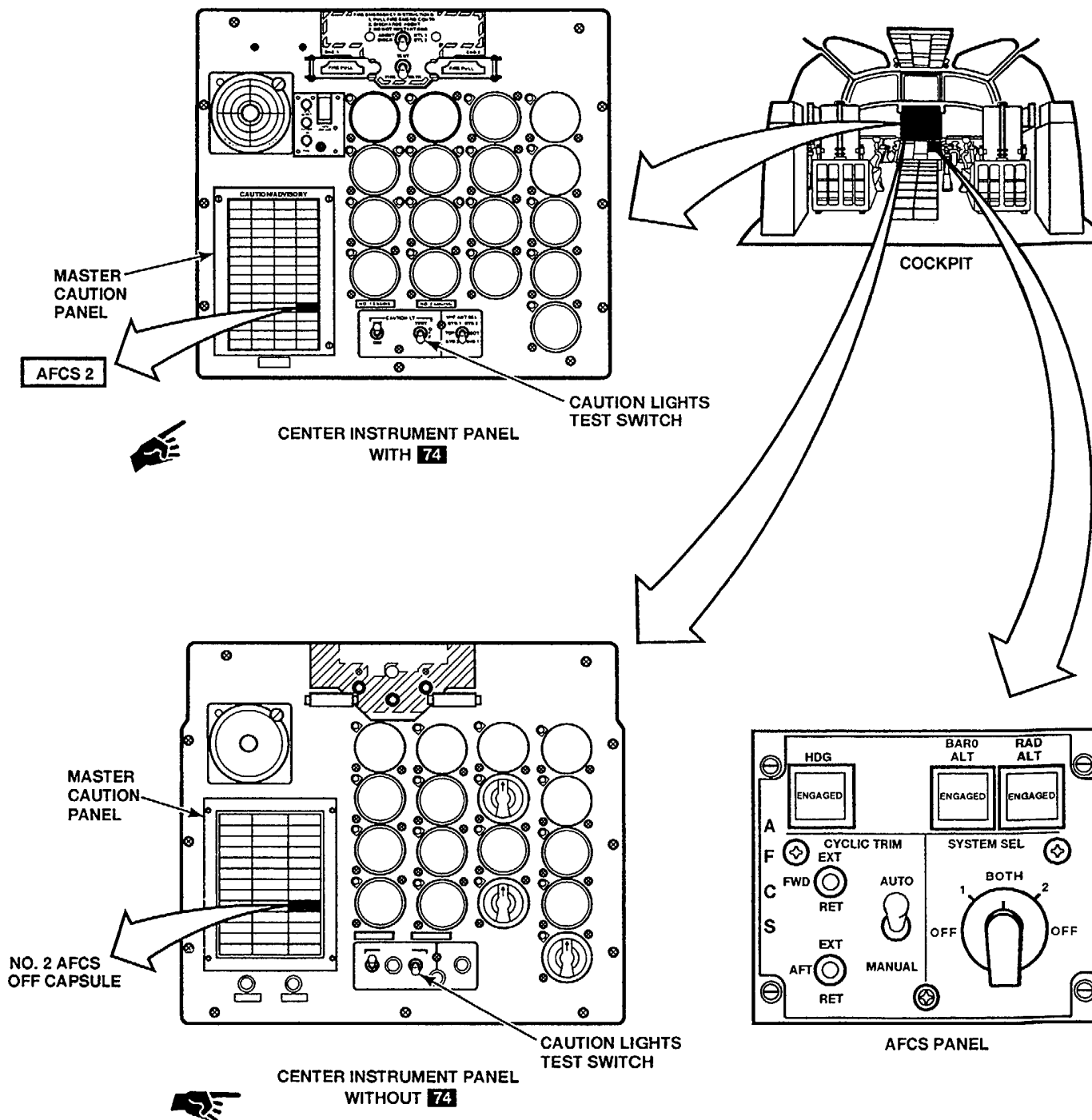
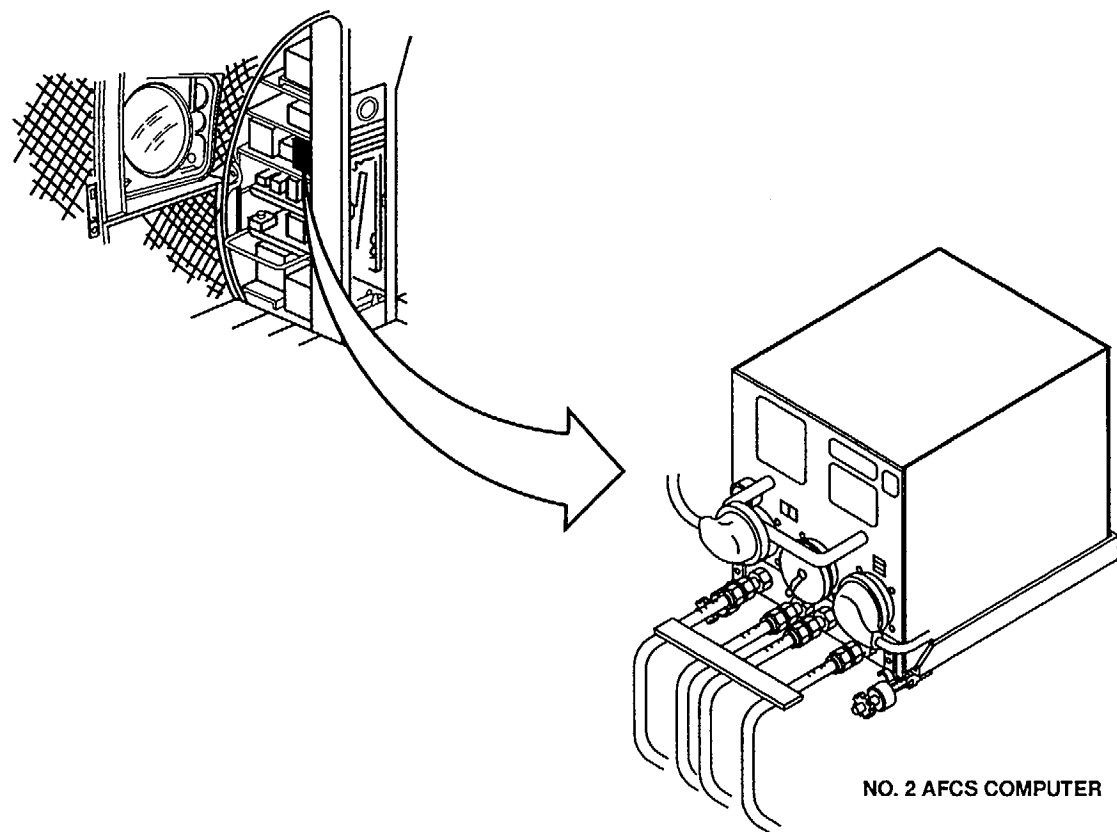

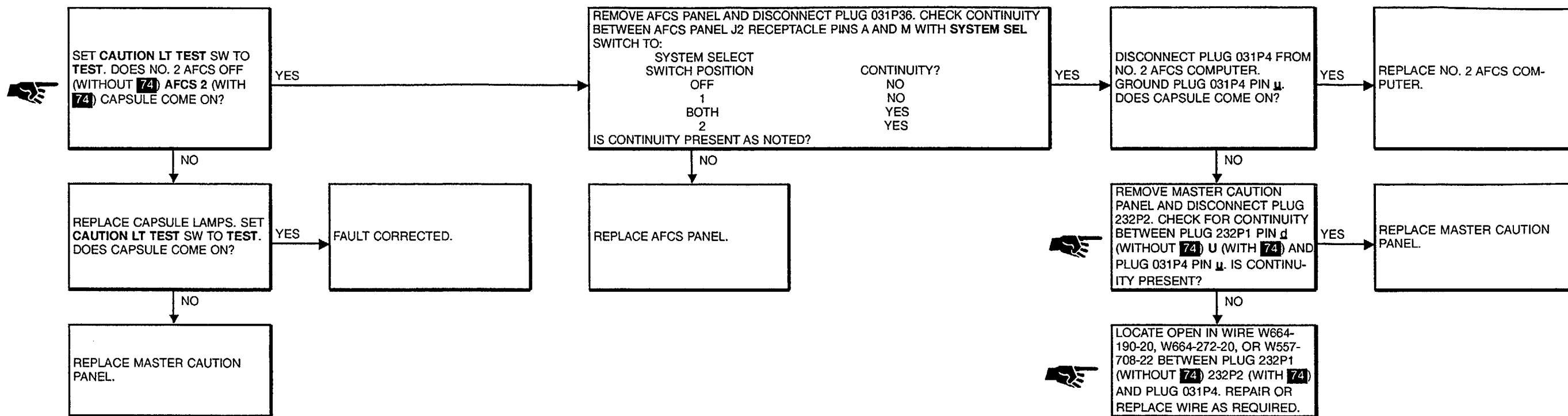

END OF TASK

Change 23 11-79

11-3.15 BOTH LCT INDICATORS NOT IN GROUND POSITION

FAULT ISOLATION PROCEDURE

INITIAL SETUP

Applicable Configurations

All

Tools:

Electrical Repairer's Tool Kit,
NSN 5180-00-323-4915
Multimeter

Materials:

None

Personnel Required:

35K10 Avionic Mechanic
35K20 Avionic Mechanic

References:

TM 55-1520-240-23
TM 55-4920-429-13

Equipment Condition:

TM 55-1520-240-23
Battery Connected
Electrical Power On
Hydraulic Power On
TM 55-4920-429-13
AFCS Line Test Set 145G0009-1
Prepared For Use

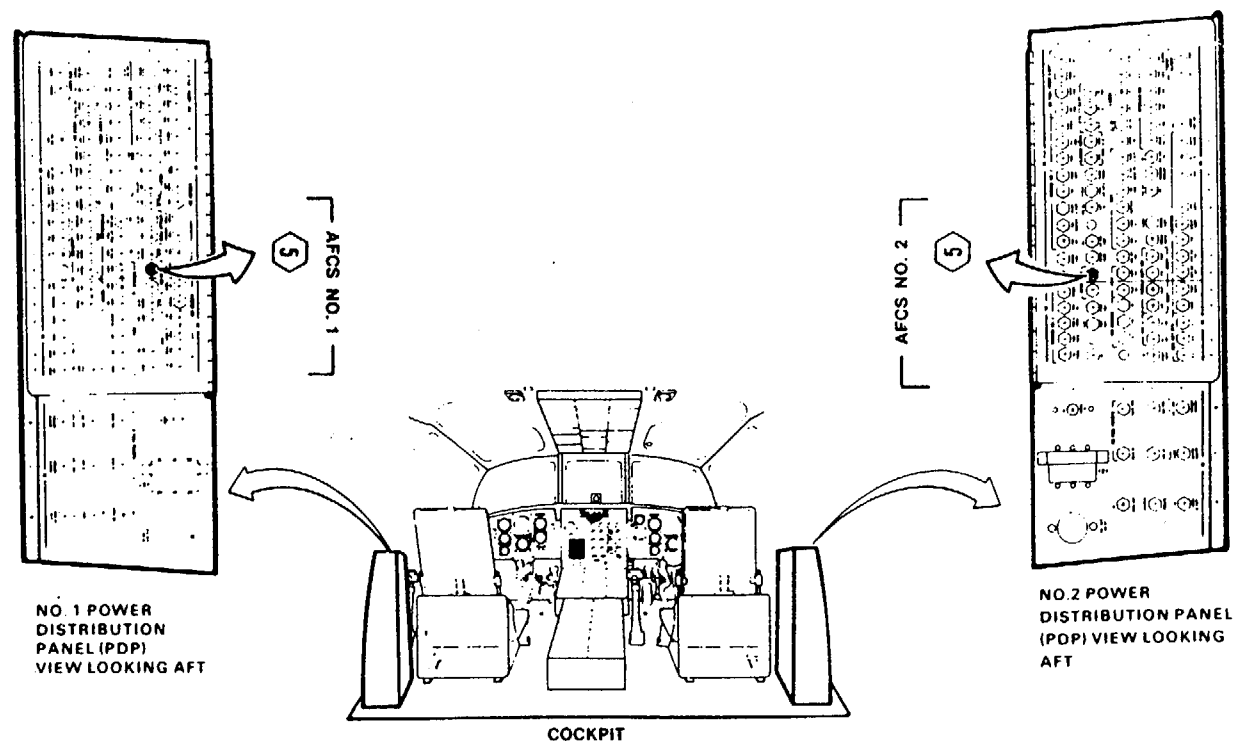
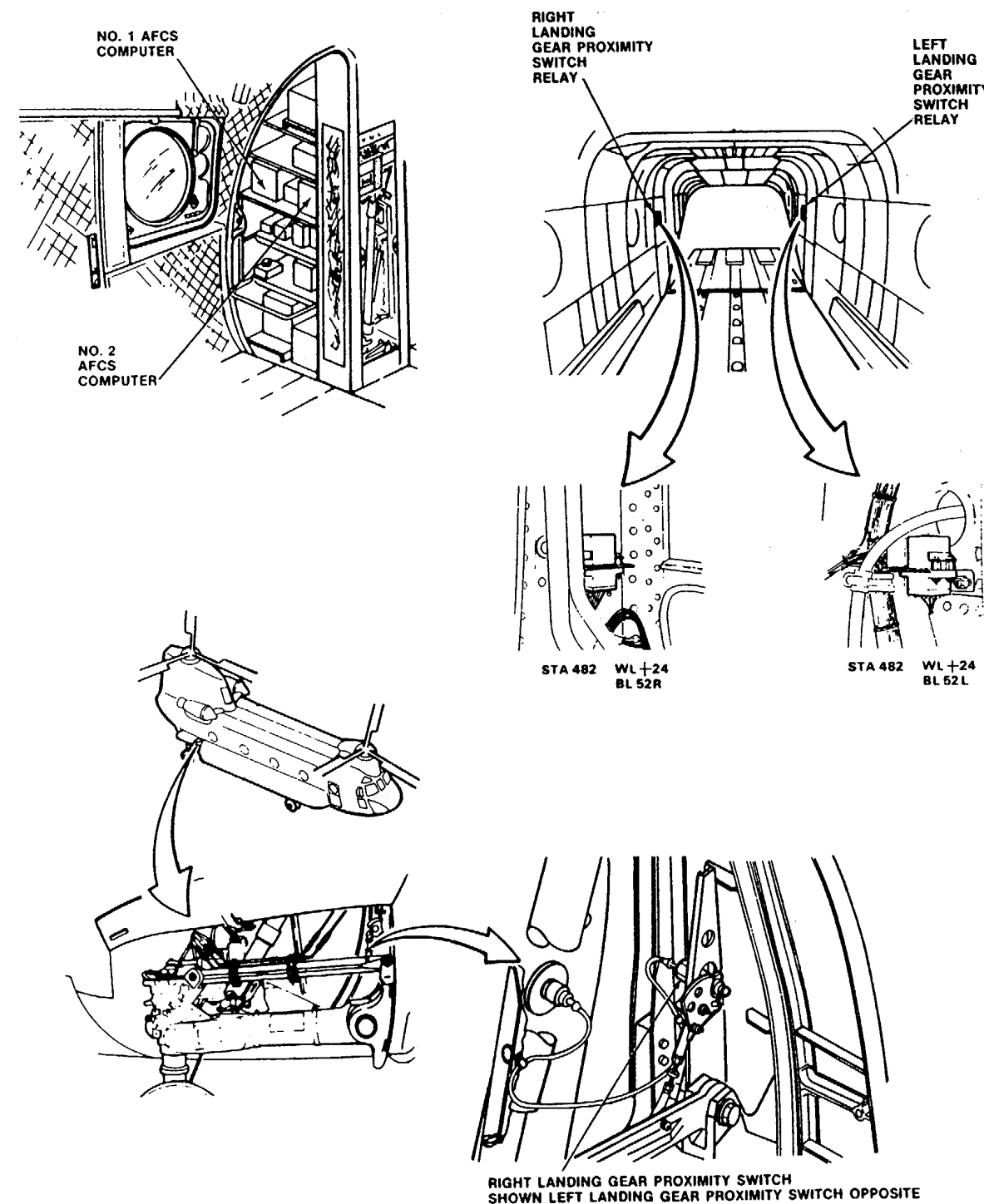

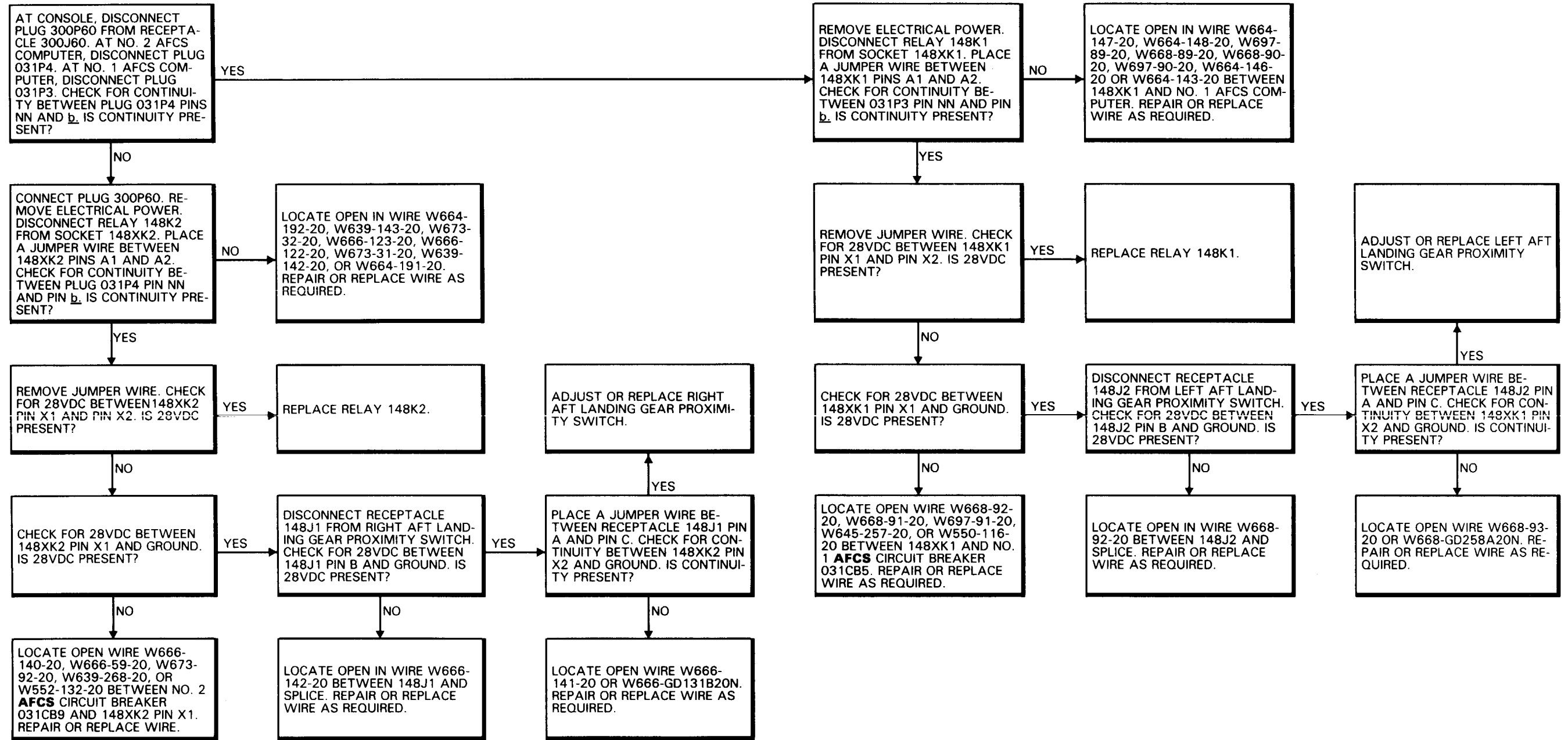

FAULT ISOLATION PROCEDURE

INITIAL SETUP

Applicable Configurations:

All

Tools:

- Electrical Repairer's Tool Kit, NSN 5180-00-323-4915
- Multimeter

Materials:

None

Personnel Required:

Avionic Mechanic (2)

References:

TM 55-1520-240-23

Equipment Condition:

- TM 55-1520-240-23:
- Battery Connected
- Electrical Power On
- Hydraulic Power On

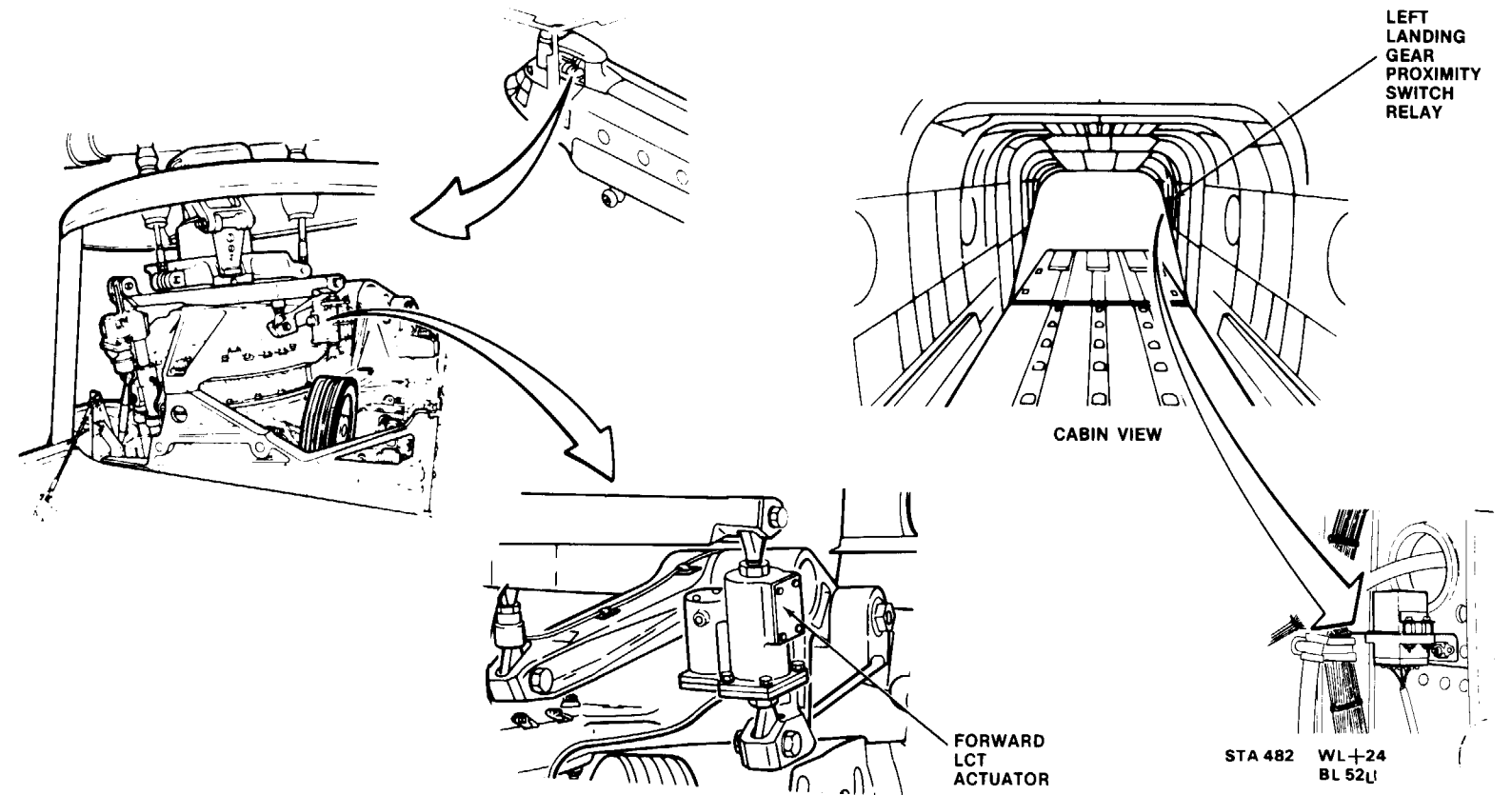
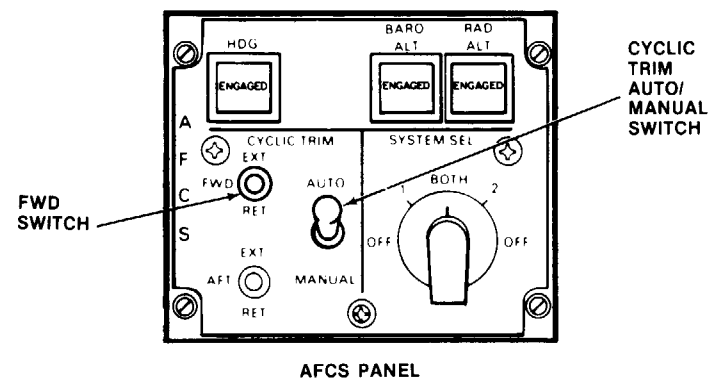
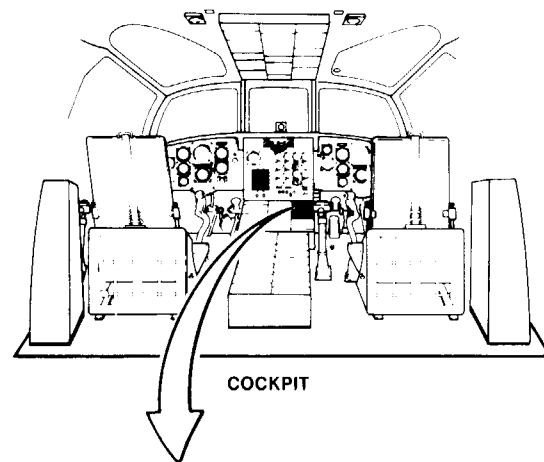
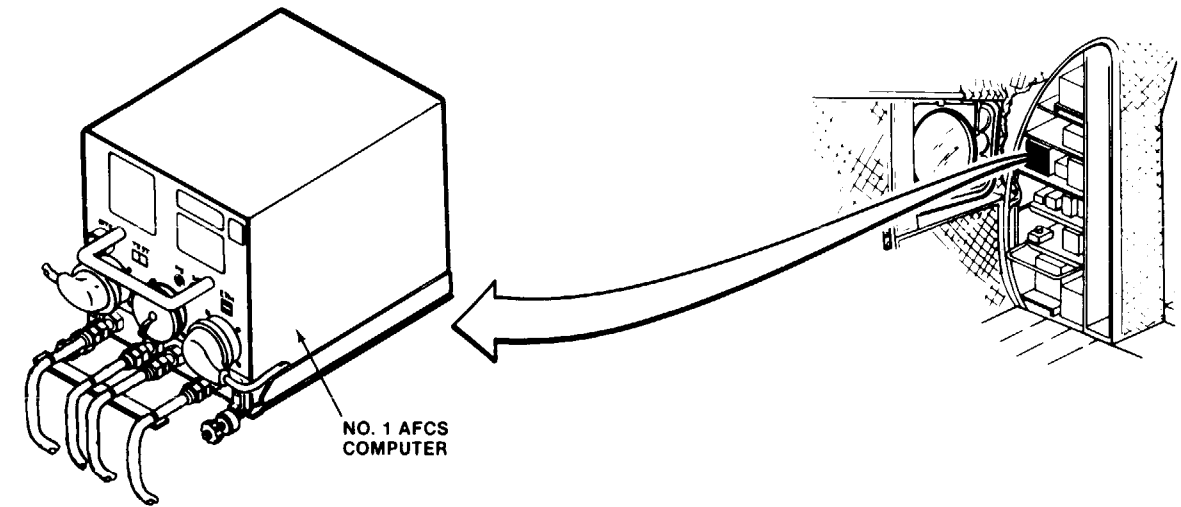

90x54

D145-11921-SPA

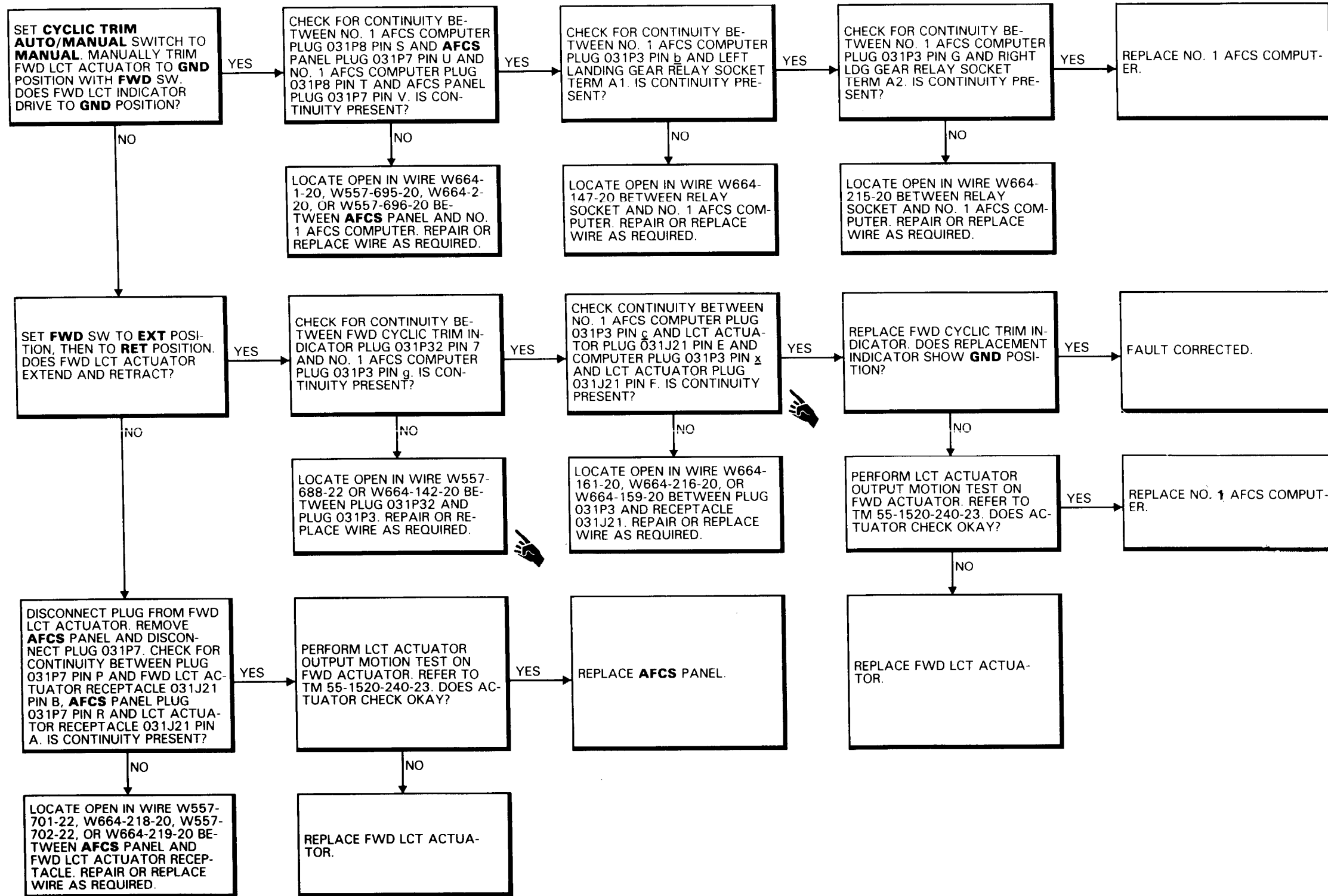

FAULT ISOLATION PROCEDURE

INITIAL SETUP

Applicable Configurations:

All

Tools:

Electrical Repairer's Tool Kit,
NSN 5180-00-323-4915
Multimeter

Materials:

None

Personnel Required

35K10 Avionic Mechanic
35K20 Avionic Mechanic

References:

TM 55-1520-240-23

Equipment Condition:

TM 55-1520-240-23
Battery Connected
Electrical Power On
Hydraulic Power On

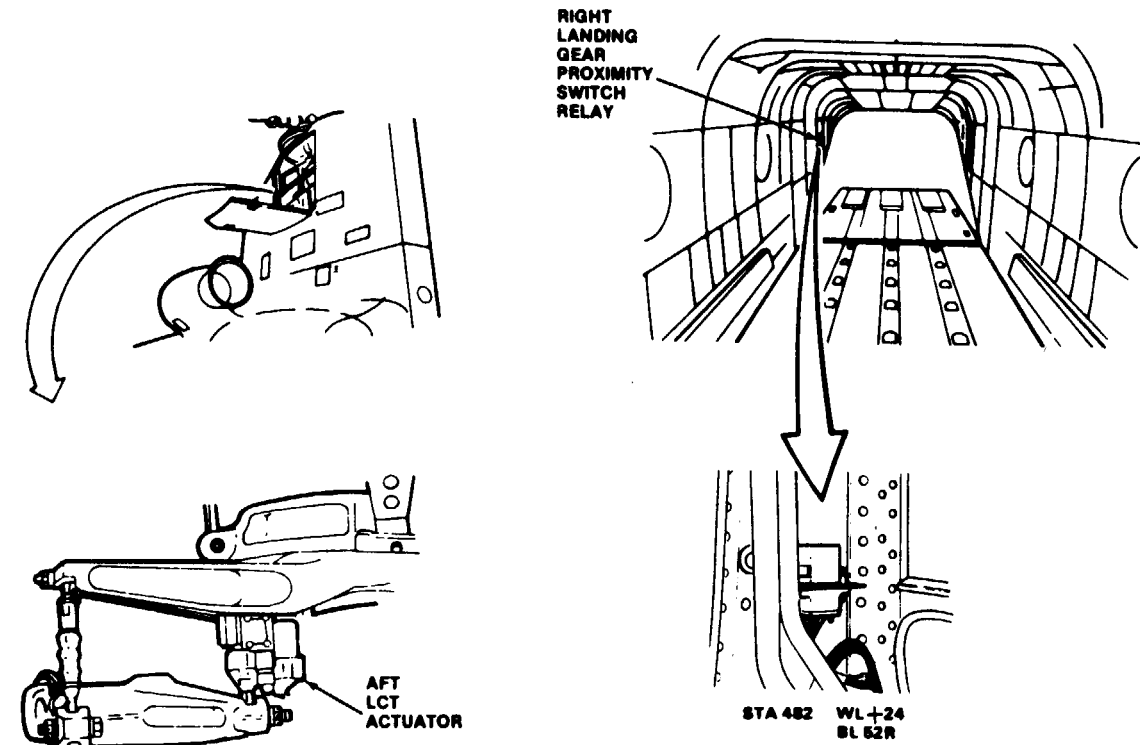
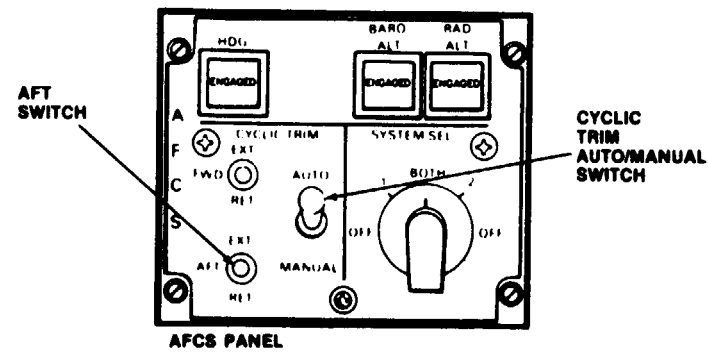
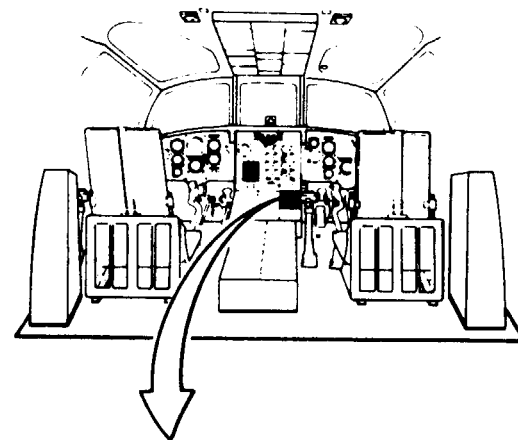
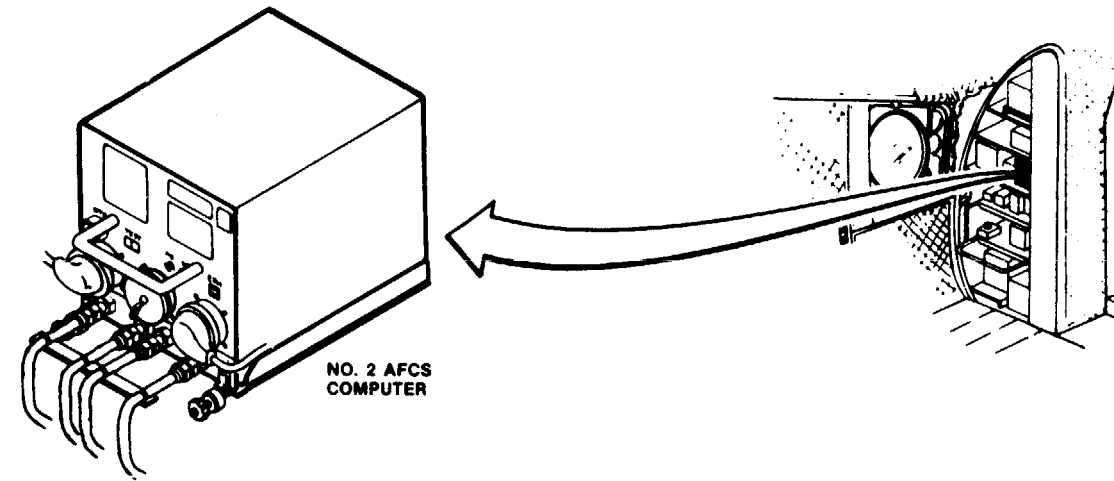

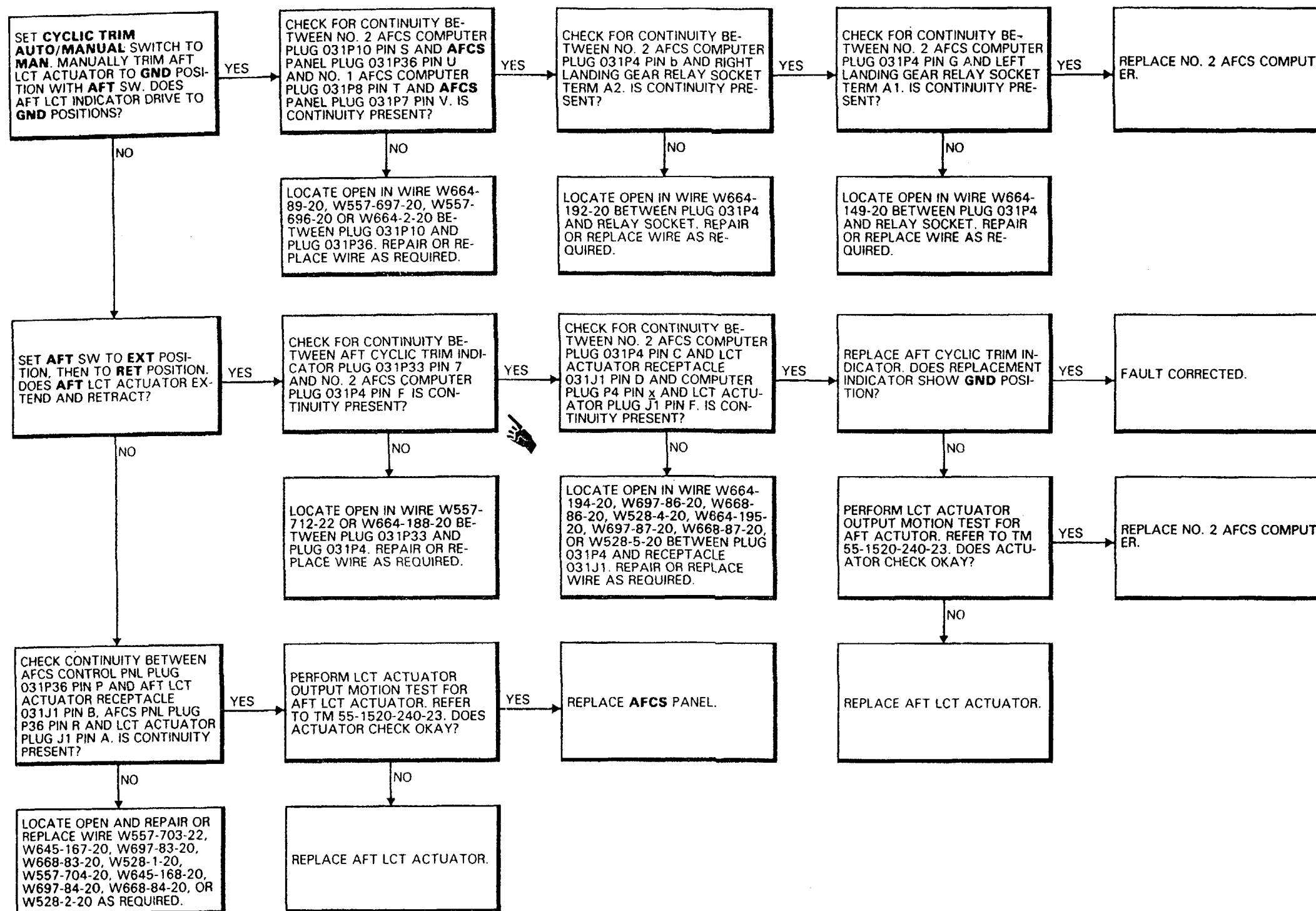

11-3.18 NO. 1 AFCS OFF (WITHOUT 74) OR AFCS 1 (WITH 74) CAPSULE DOES NOT GO OUT WHEN SYSTEM SELECTED

FAULT ISOLATION PROCEDURE

INITIAL SETUP

Applicable Configurations:

All

Tools:

Electrical Repairer Tool Kit,
NSN 5180-00-323-4915
Multimeter

Materials:

None

Personnel Required:

Avionic Mechanic (2)

References:

TM 55-1520-240-23
TM 11-1520-240-23

Equipment Condition:

TM 55-1520-240-23:
Battery Connected
Electrical Power On
Hydraulic Power On

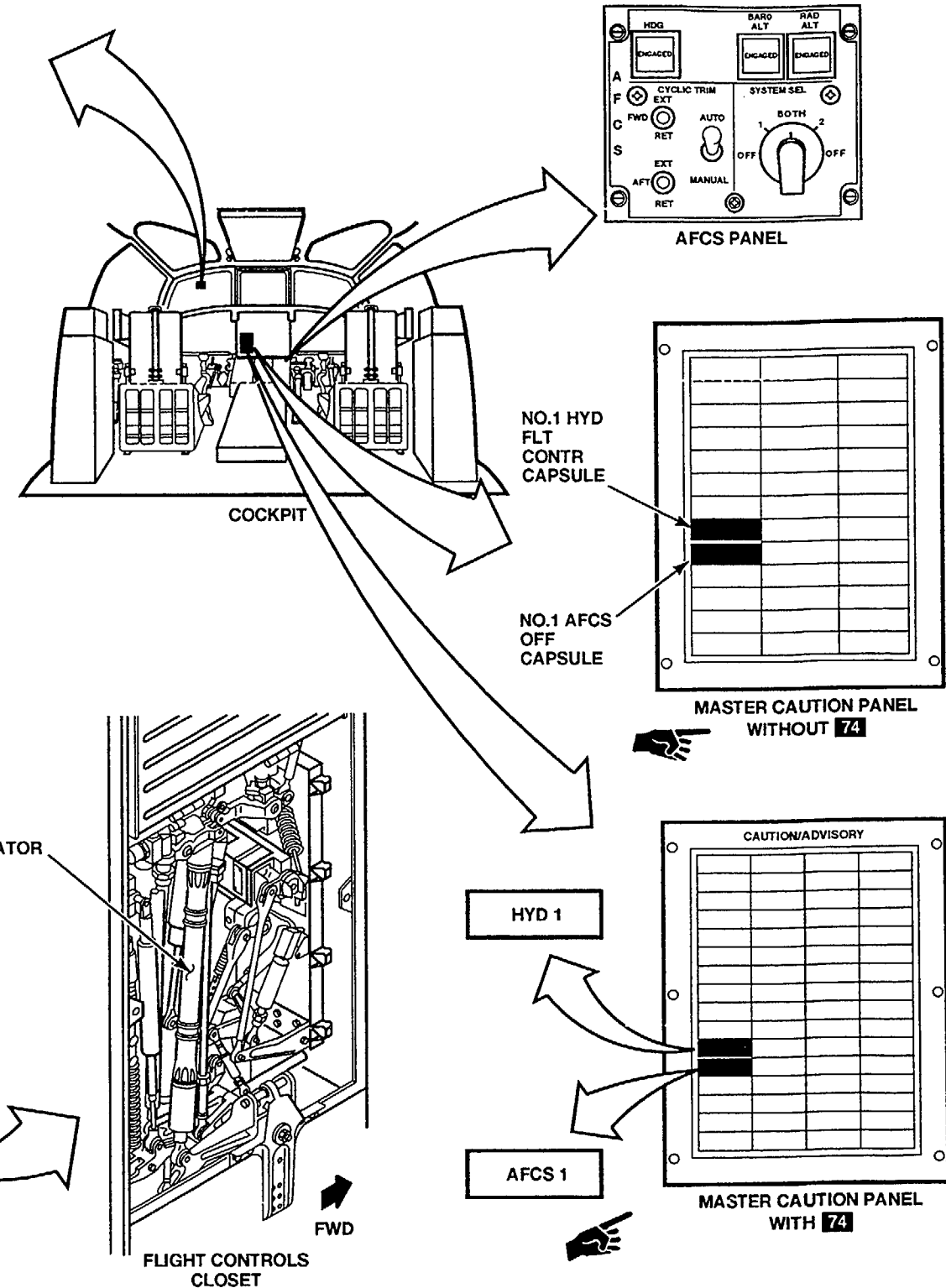
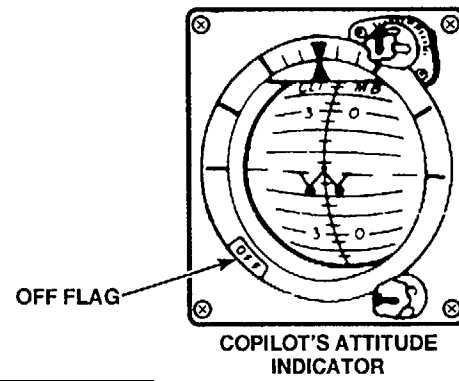

A65462

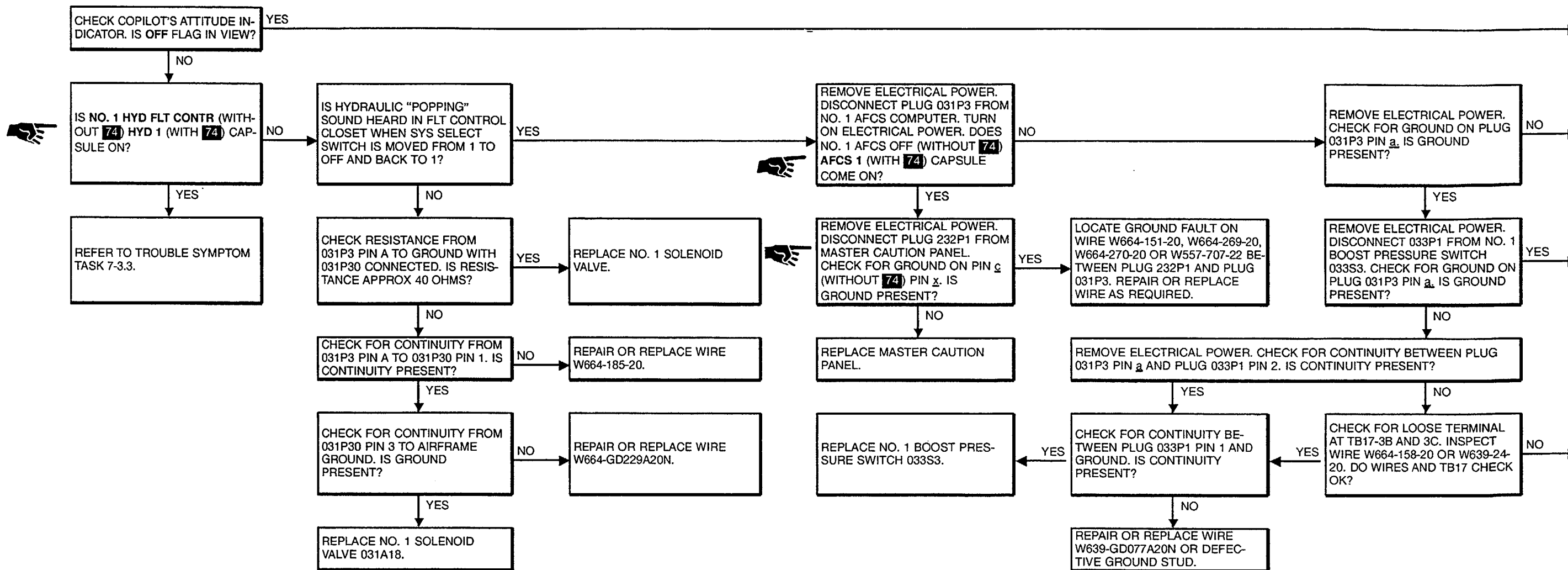

11-3.18 NO. 1 AFCS OFF (WITHOUT 74) OR AFCS 1 (WITH 74) CAPSULE DOES NOT GO OUT WHEN SYSTEM SELECTED (Continued)

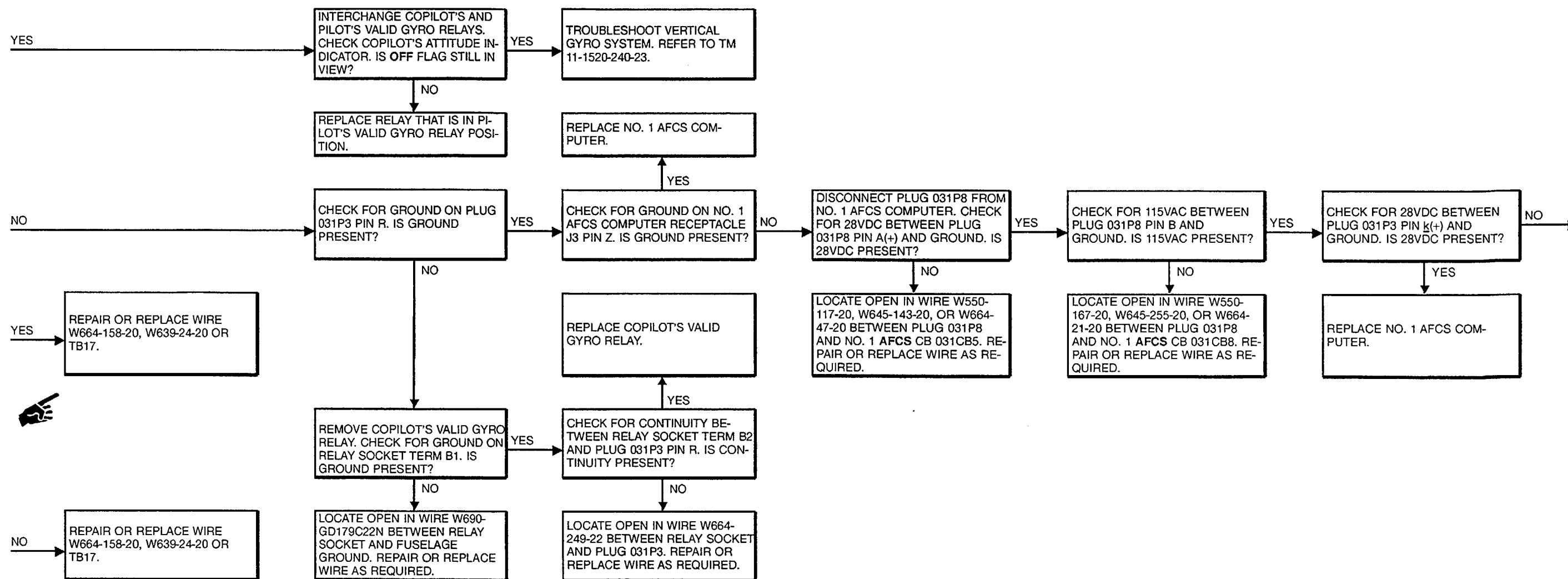

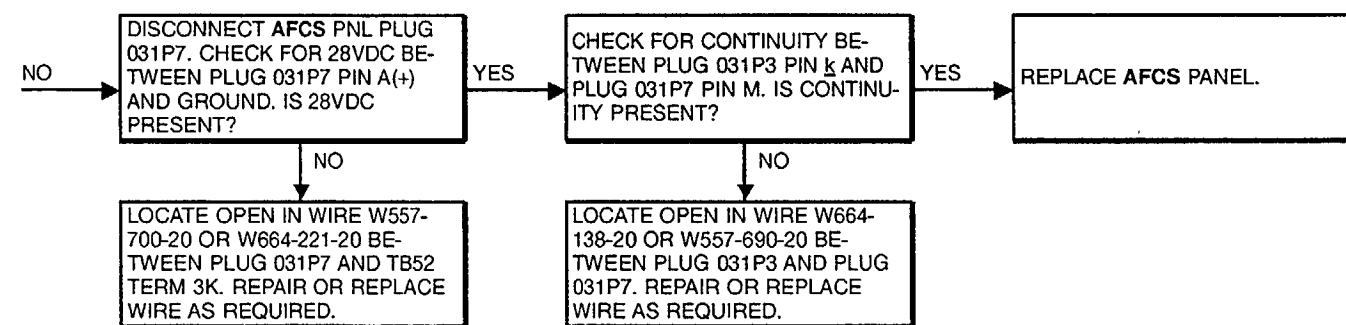

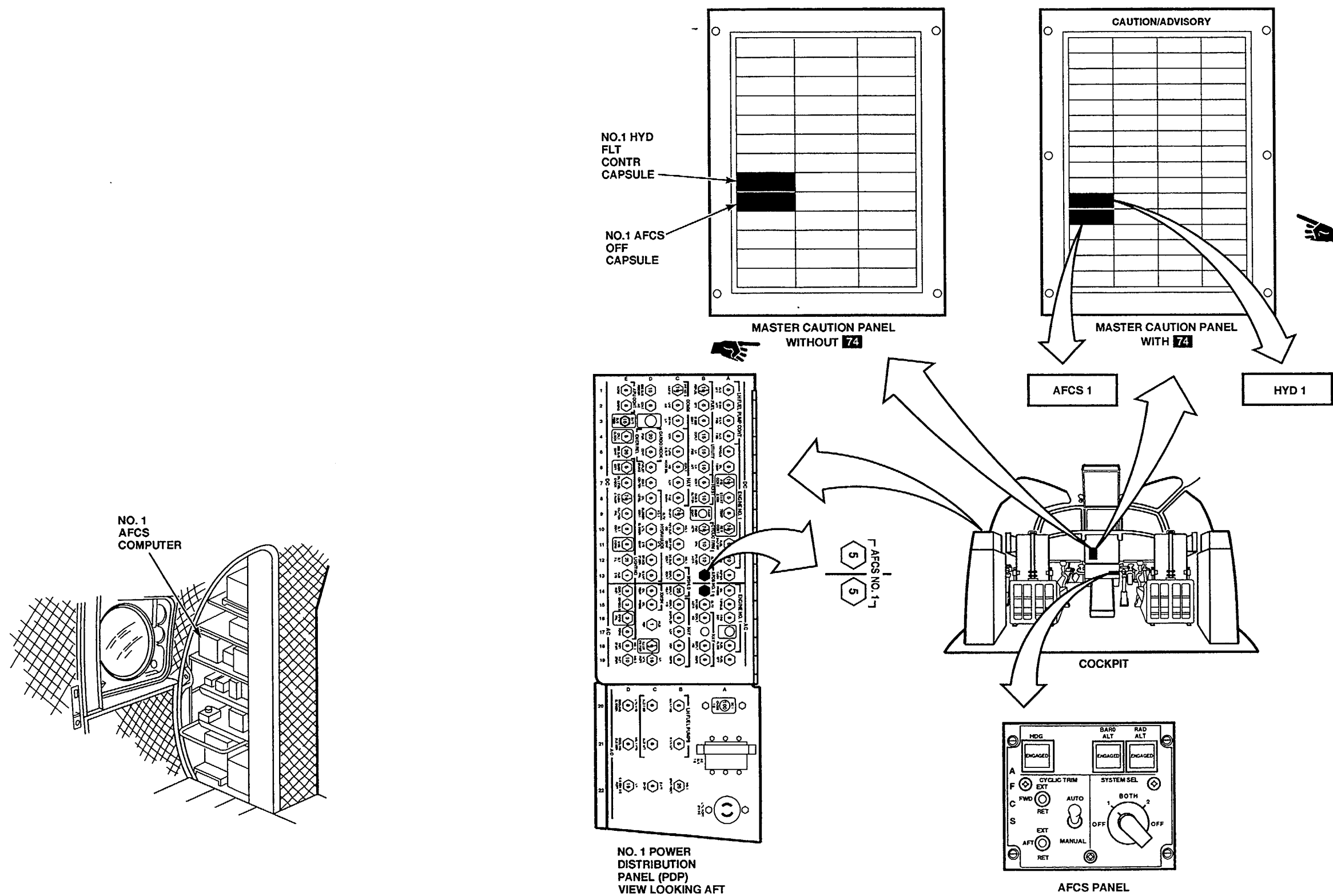

A67662

11-3.18 NO. 1 AFCS OFF CAPSULE DOES NOT GO OUT WHEN SYSTEM SELECTED (Continued)

11-3.18

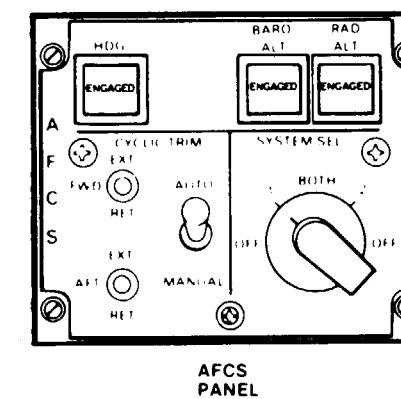
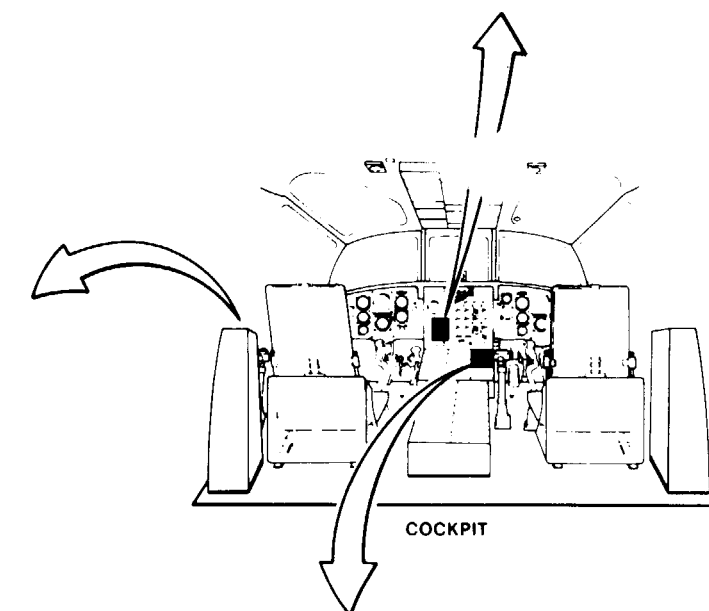
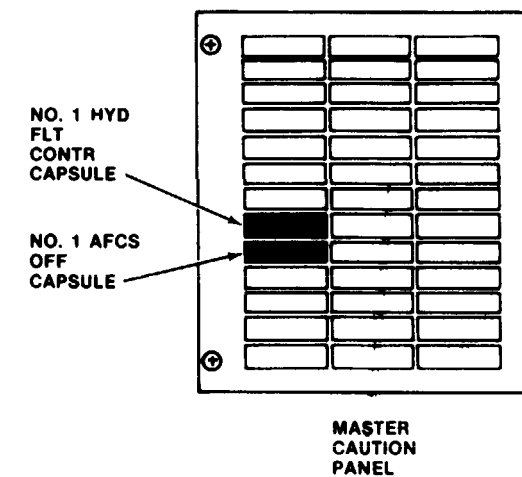
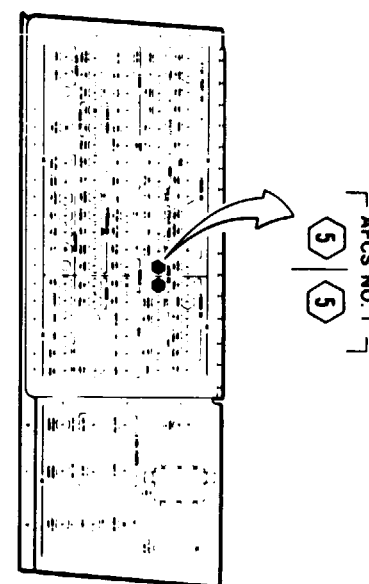
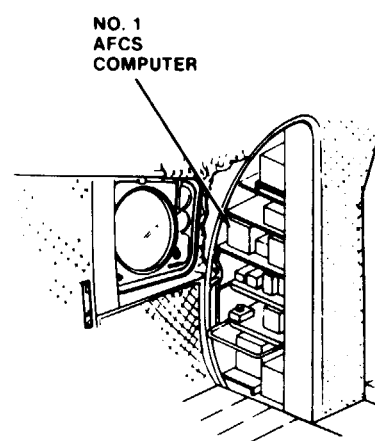

FAULT ISOLATION PROCEDURE

INITIAL SETUP

Applicable Configurations:

All

Tools:

Electrical Repairer's Tool Kit,
NSN 5180-00-323-4915
Multimeter

Materials:

None

Personnel Required:

35K10 Avionic Mechanic
35K20 Avionic Mechanic

References:

TM 55-1520-240-23
TM 55-4920-429-13

Equipment Condition:

TM 55-1520-240-23
Battery Connected
Electrical Power On
Hydraulic Power On
TM 55-4920-429-13
AFCS Line Test Set 145G0009-1
Prepared for Use

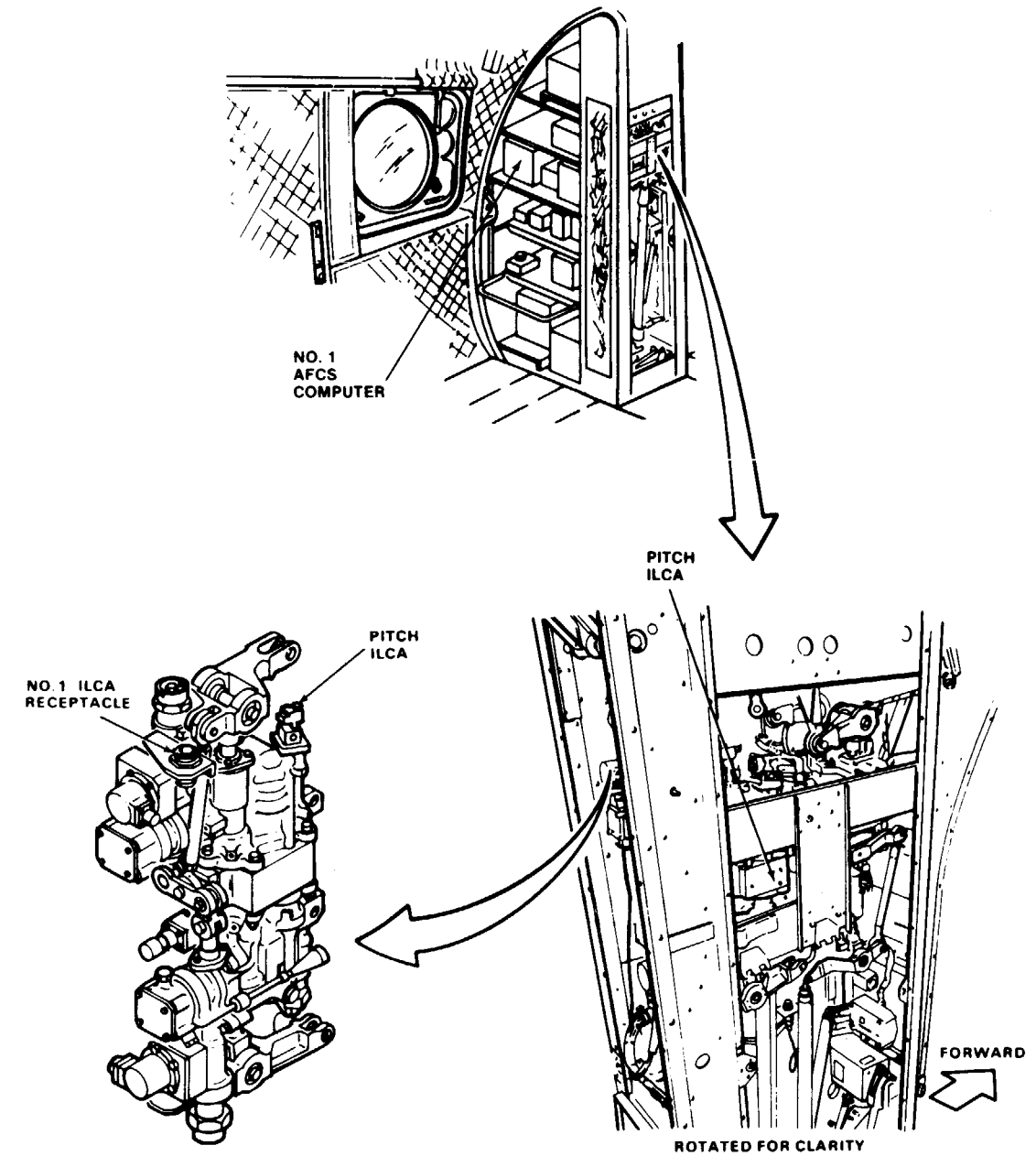
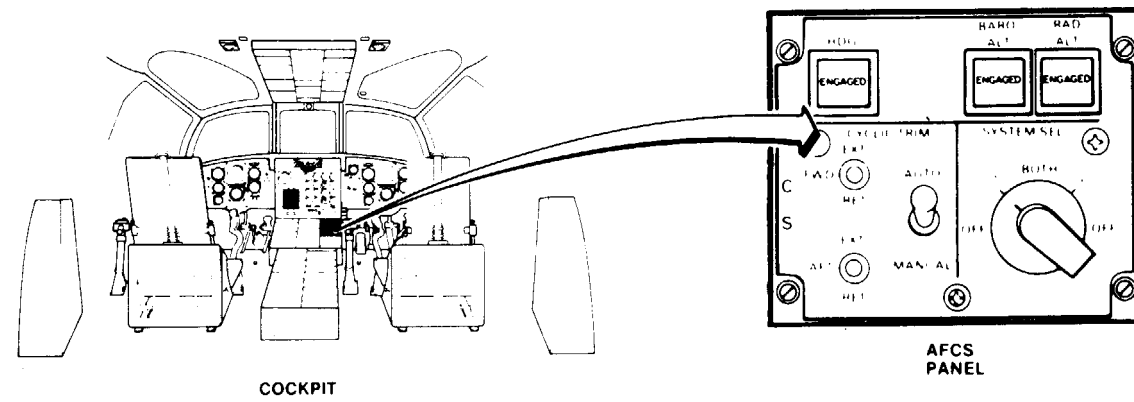

45 x 54

D145-11950-SPA

GO TO NEXT PAGE

11-3.19 NO. 1 PITCH ILCA HAS ENGAGE TRANSIENT (Continued)

11-3.19

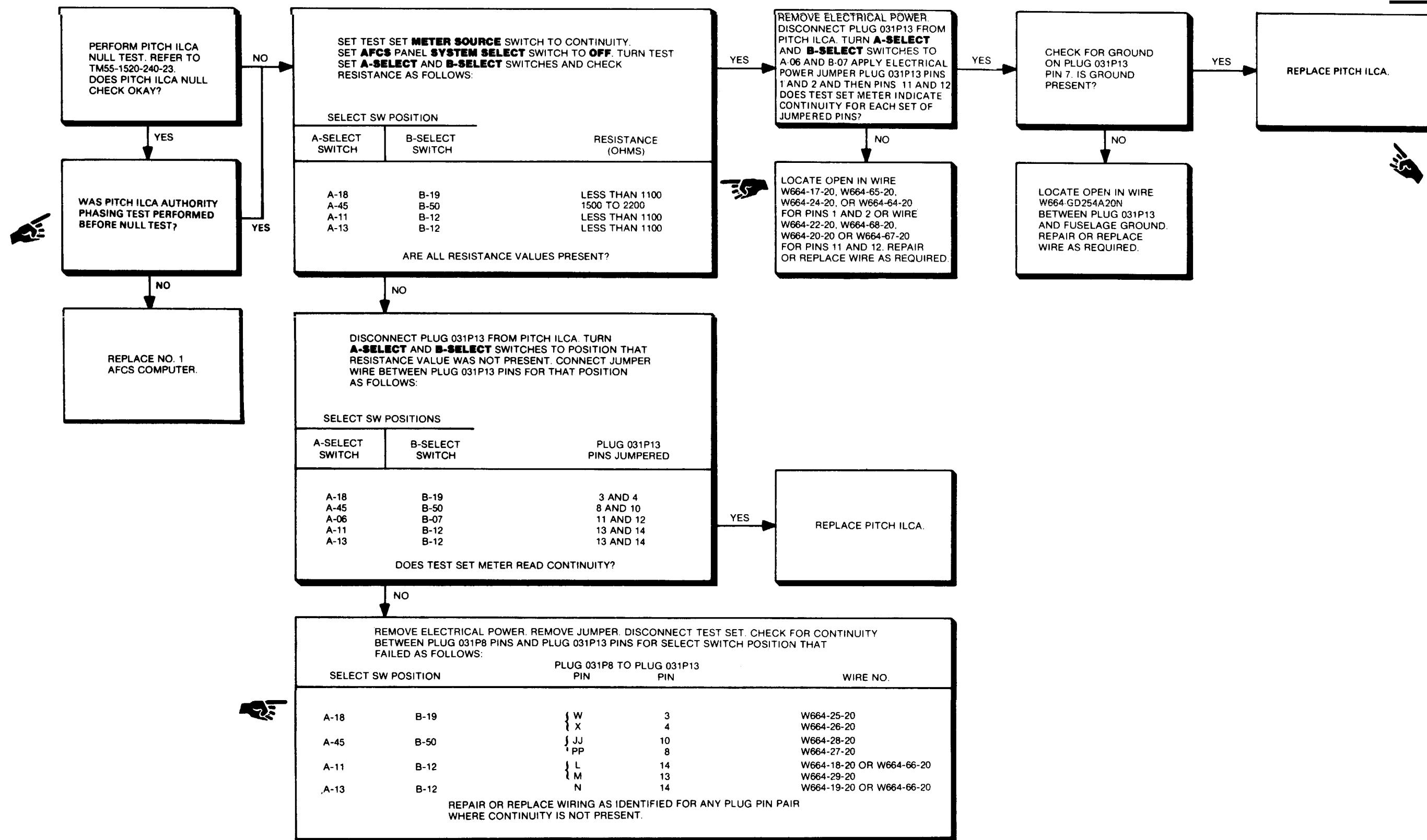

11-3.20 NO. 1 ROLL HAS ILCA ENGAGE TRANSIENT

FAULT ISOLATION PROCEDURE

INITIAL SETUP

Applicable Configurations:

All

Tools:

- Electrical Repairer's Tool Kit,
NSN 5180-00-323-4915
- Multimeter

Materials:

None

Personnel Required:

- 35K10 Avionic Mechanic
- 35K20 Avionic Mechanic

References:

- TM 55-1520-240-23
- TM 55-4920-429-13

Equipment Condition:

- TM 55-1520-240-23
 - Battery Connected
 - Electrical Power On
 - Hydraulic Power On
- TM 55-4920-429-13
 - AFCS Line Test Set Prepared For Use

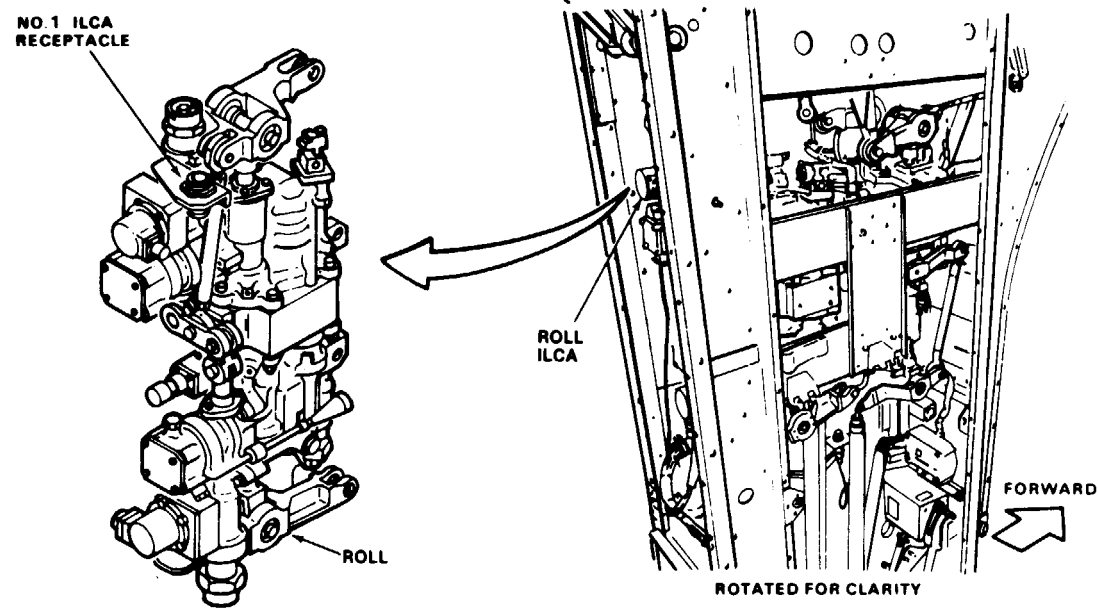
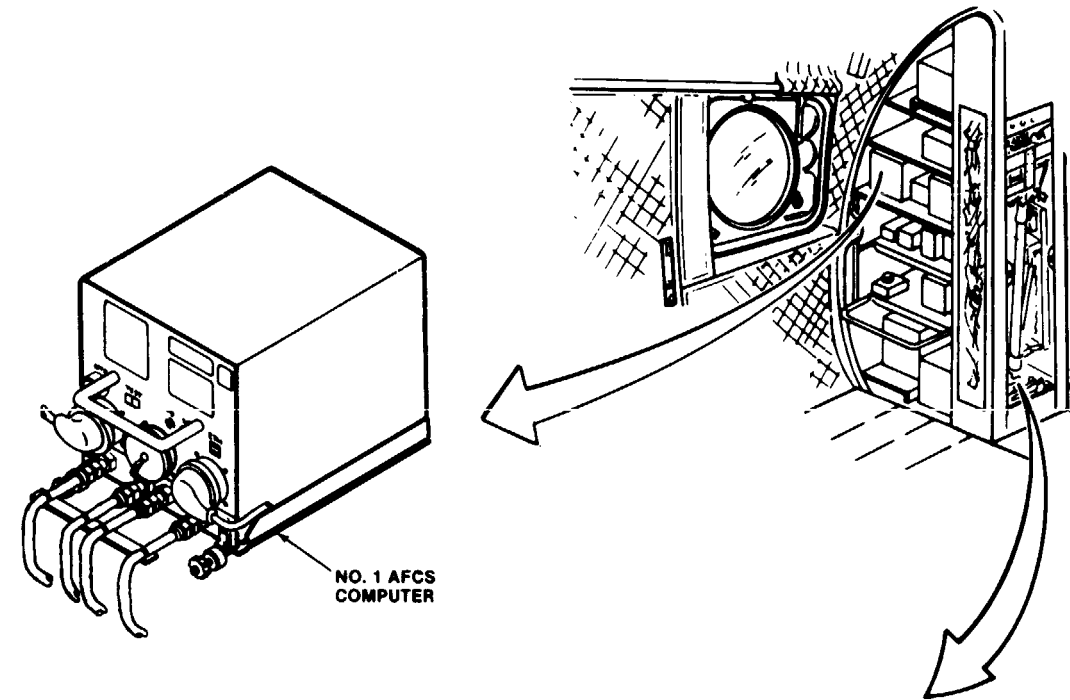
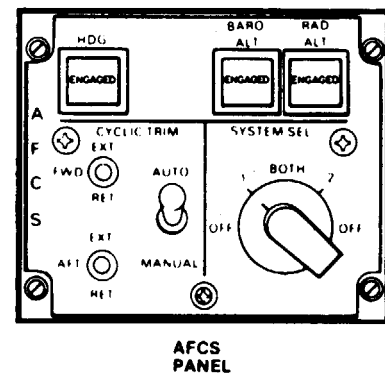
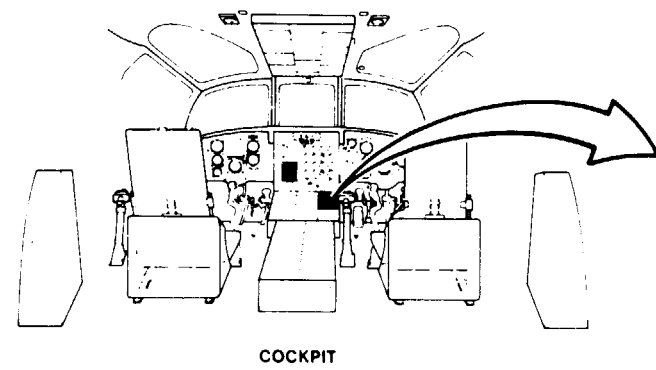

11-3.20 NO. 1 ROLL ILCA HAS ENGAGE TRANSIENT (Continued)

11-3.20

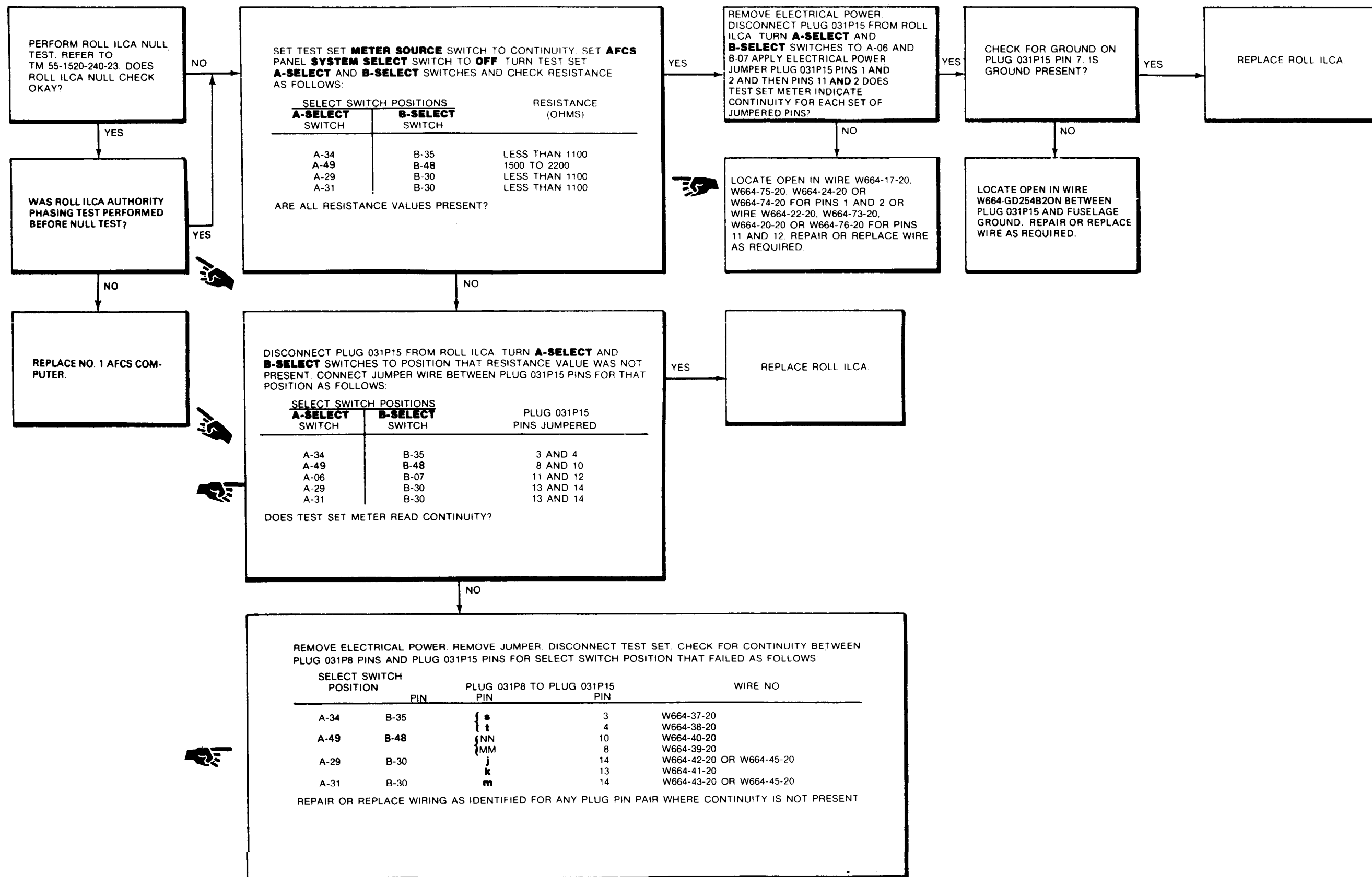

FAULT ISOLATION PROCEDURE

INITIAL SETUP

Applicable Configurations:

All

Tools:

Electrical Repairer's Tool Kit,
NSN 5180-00-323-4915
Multimeter

Materials:

None

Personnel Required:

35K10 Avionic Mechanic
35K20 Avionic Mechanic

References:

TM 55-1520-240-23
TM 55-4920-429-13

Equipment Condition:

TM 55-1520-240-23
Battery Connector
Electrical Power On
Hydraulic Power On
TM 55-4920-429-13
AFCS Line Test Set 145G0009-1
Prepared For Use

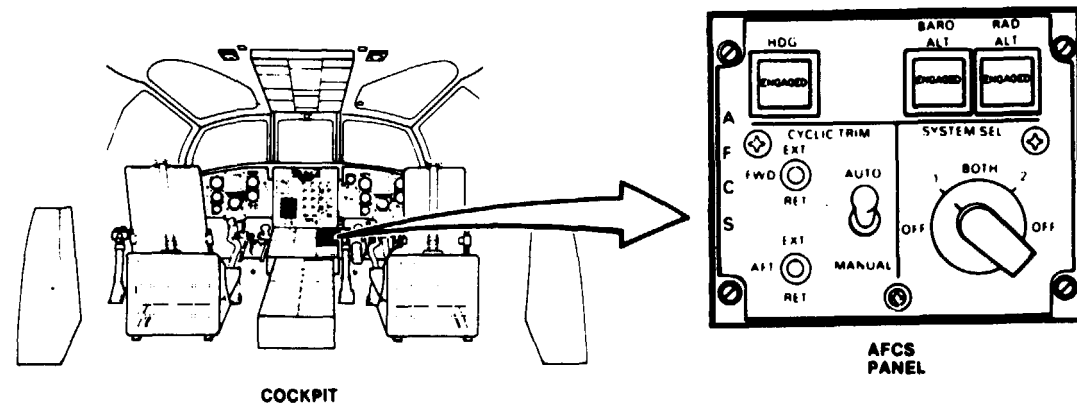

90154

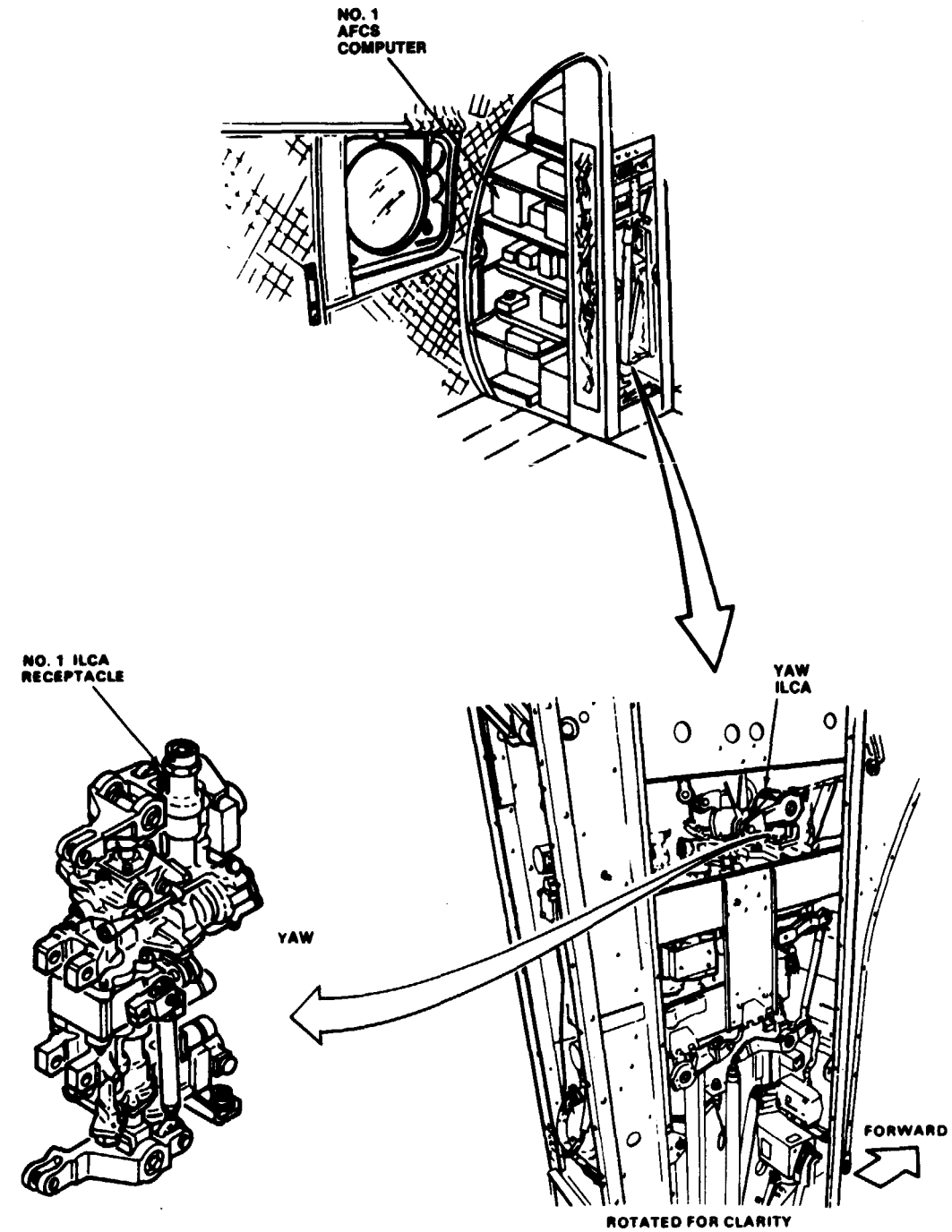

D48-11082-8PM

GO TO NEXT PAGE

11-3.21 NO. 1 YAW ILCA HAS ENGAGE TRANSIENT (Continued)

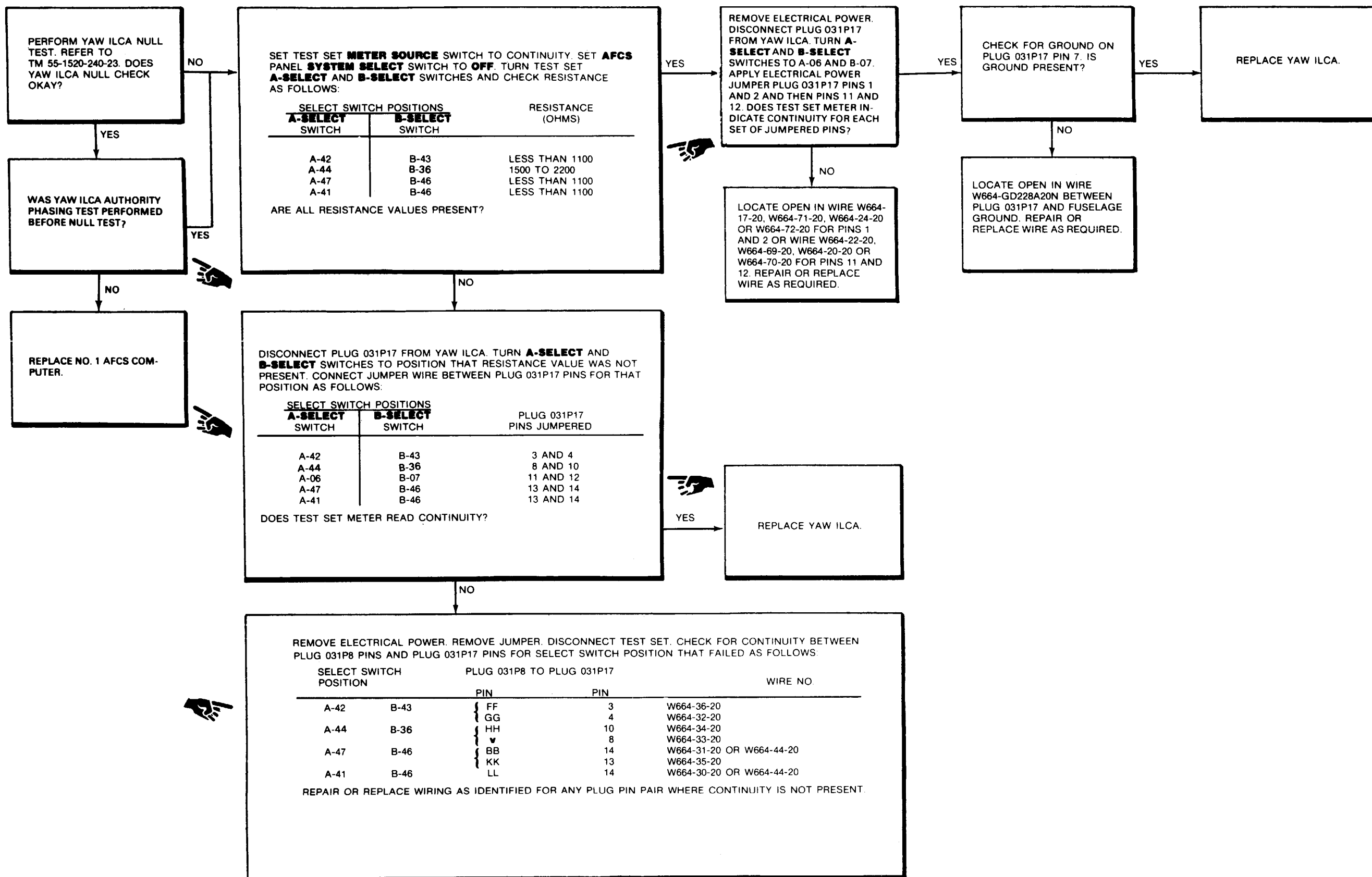

END OF TASK

11-3.22 NO. 1 YAW ILCA DOES NOT EXTEND OR RETRACT WHEN PEDALS ARE MOVED

FAULT ISOLATION PROCEDURE

INITIAL SETUP

Applicable Configurations:

All

Tools:

- Electrical Repairer's Tool Kit,
NSN 5180-00-323-4915
- Multimeter

Materials:

None

Personnel Required:

- 35K10 Avionic Mechanic
- 35K20 Avionic Mechanic

References:

- TM 55-1520-240-23
- TM 55-4920-429-13

Equipment Condition:

- TM 55-1520-240-23
- Battery Connected
- Electrical Power On
- Hydraulic Power On
- TM 55-4920-429-13
- AFCS Line Test Set 145G0009-1
- Prepared For Use

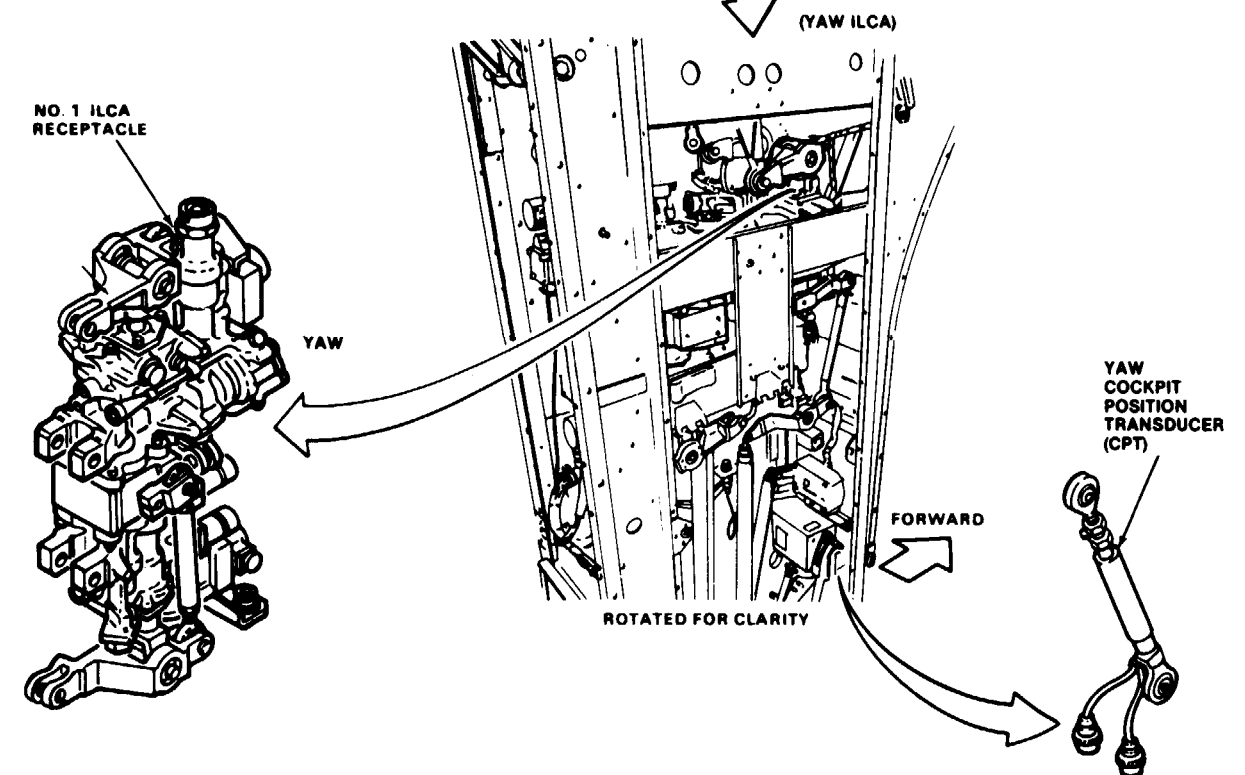
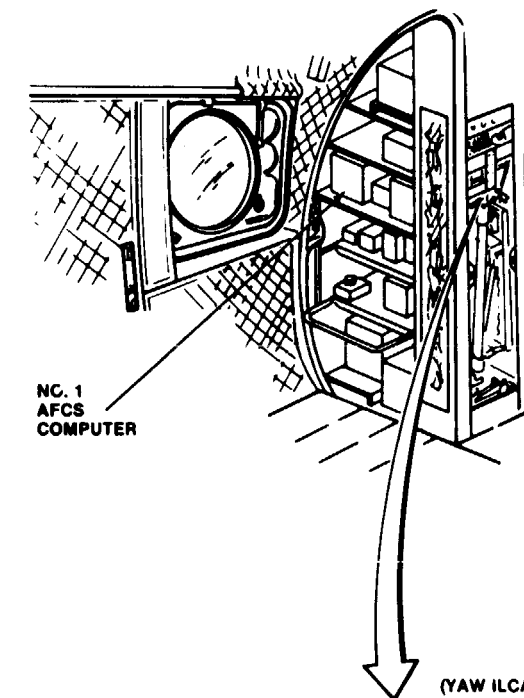
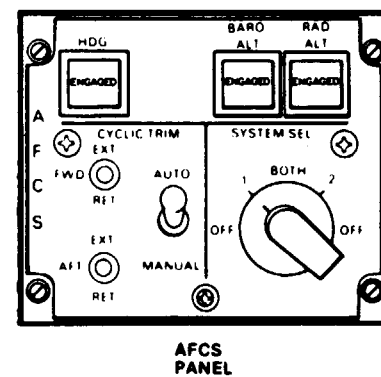
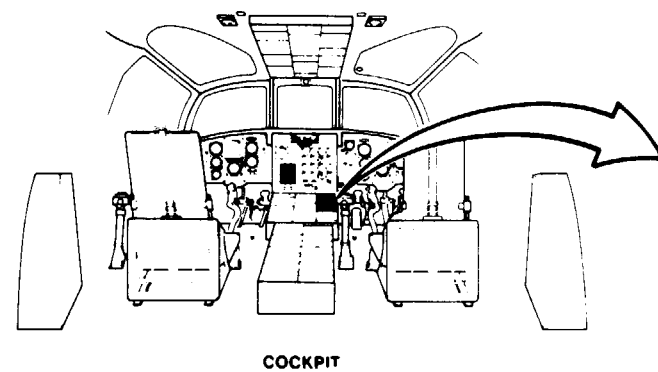

90154

D145-11954 SPA

11-3.22 NO. 1 YAW ILCA DOES NOT EXTEND OR RETRACT WHEN PEDALS ARE MOVED (Continued)

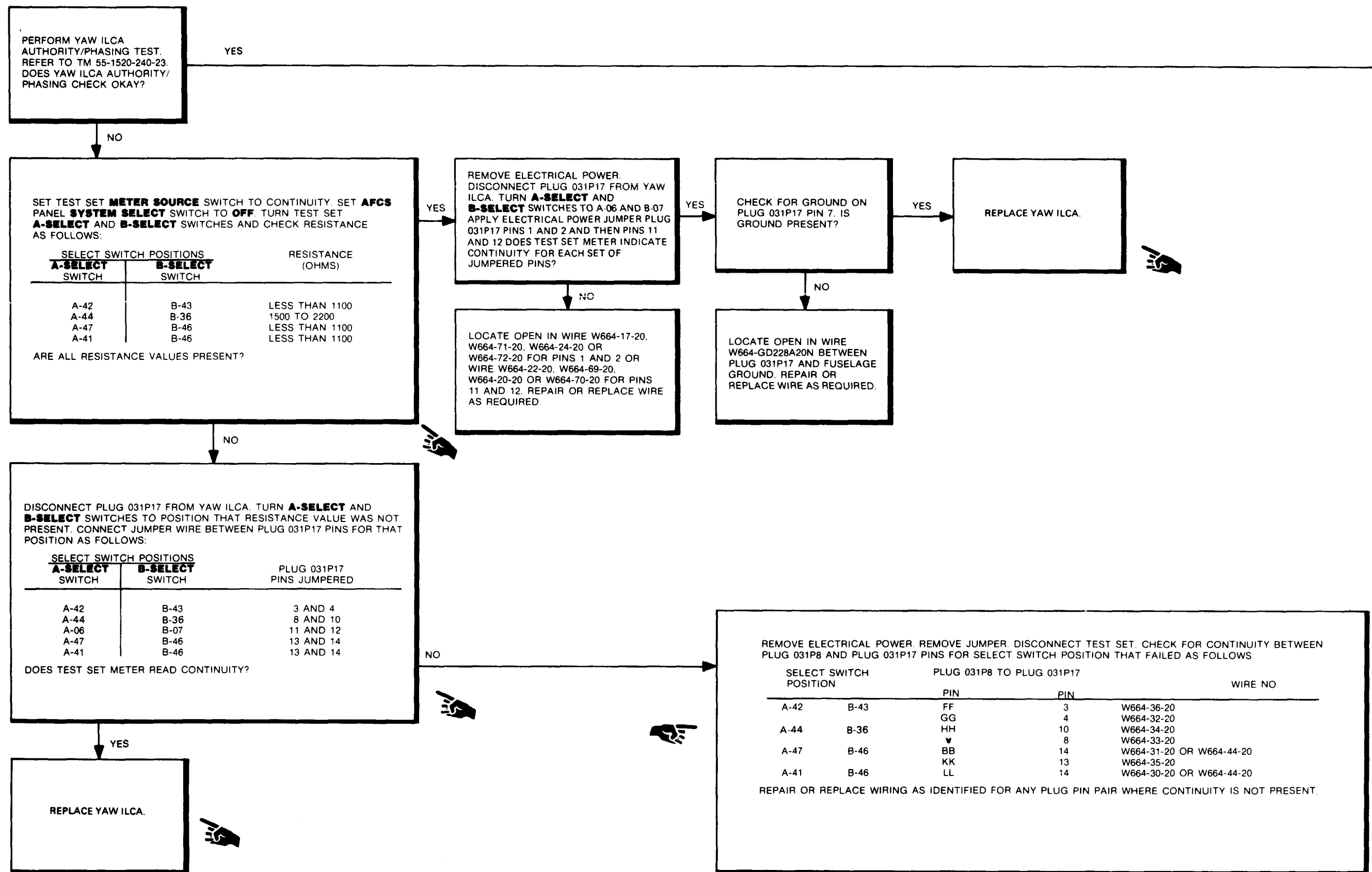

GO TO NEXT PAGE

11-3.22 NO. 1 YAW ILCA DOES NOT EXTEND OR RETRACT WHEN PEDALS ARE MOVED (Continued)

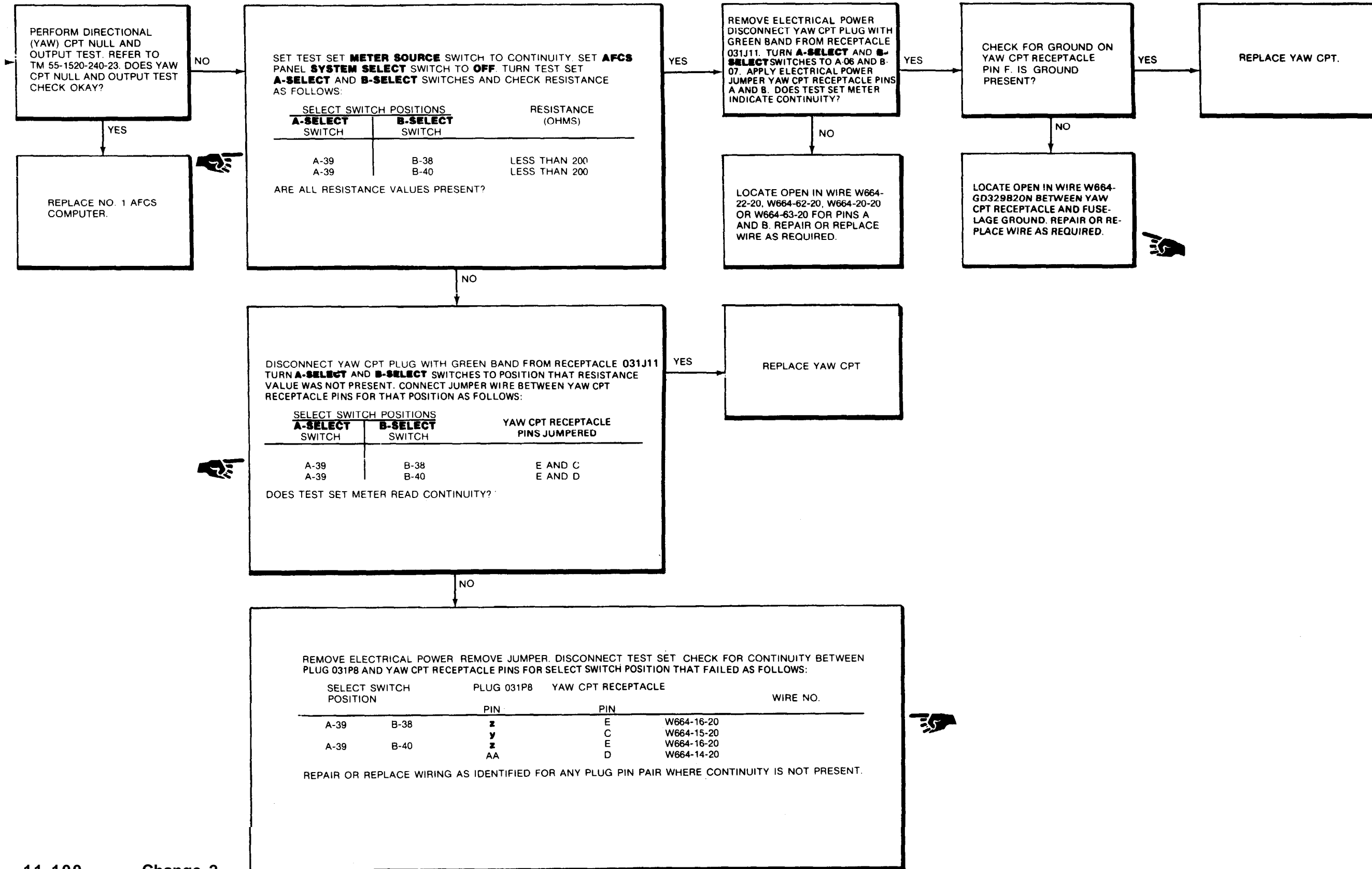

11-3.22 NO. 1 YAW ILCA DOES NOT EXTEND OR RETRACT WHEN PEDALS ARE MOVED (Continued)

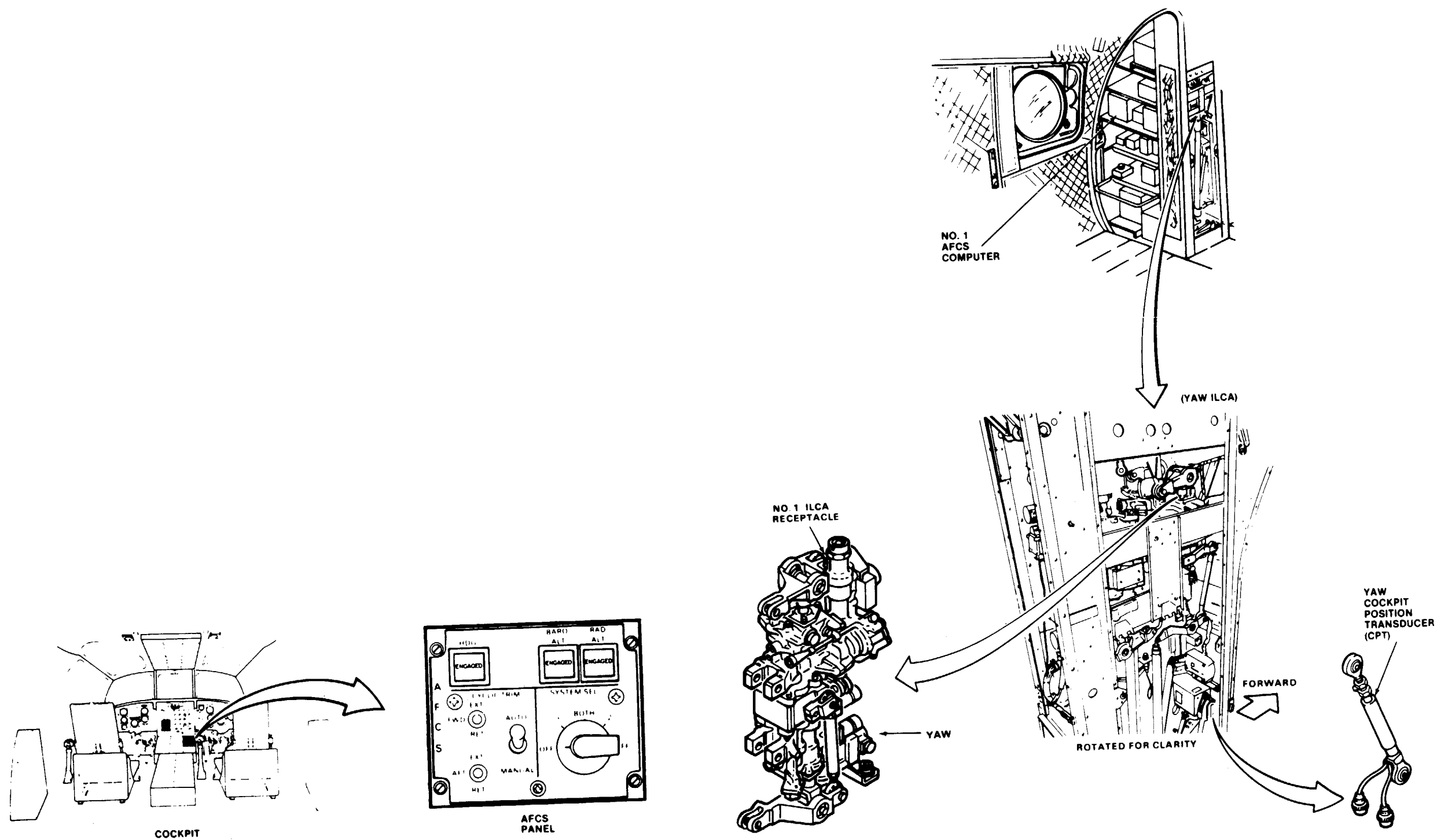

90+54

D145-12170- SPA

END OF TASK

11-3.23 NO. 1 ROLL ILCA DOES NOT EXTEND OR RETRACT WITH LATERAL STICK MOTION

FAULT ISOLATION PROCEDURE

INITIAL SETUP

Applicable Configurations:

All

Tools:

Electrical Repairer's Tool Kit,
NSN 5180-00-323-4915
Multimeter

Materials:

None

Personnel Required:

35K10 Avionic Mechanic
35K20 Avionic Mechanic

References:

TM 55-1520-240-23
TM 55-4920-429-13

Equipment Condition:

TM 55-1520-240-23
Battery Connected
Electrical Power On
Hydraulic Power On
TM 55-4920-429-13
AFCS Line Test Set 145G0009-1
Prepared For Use

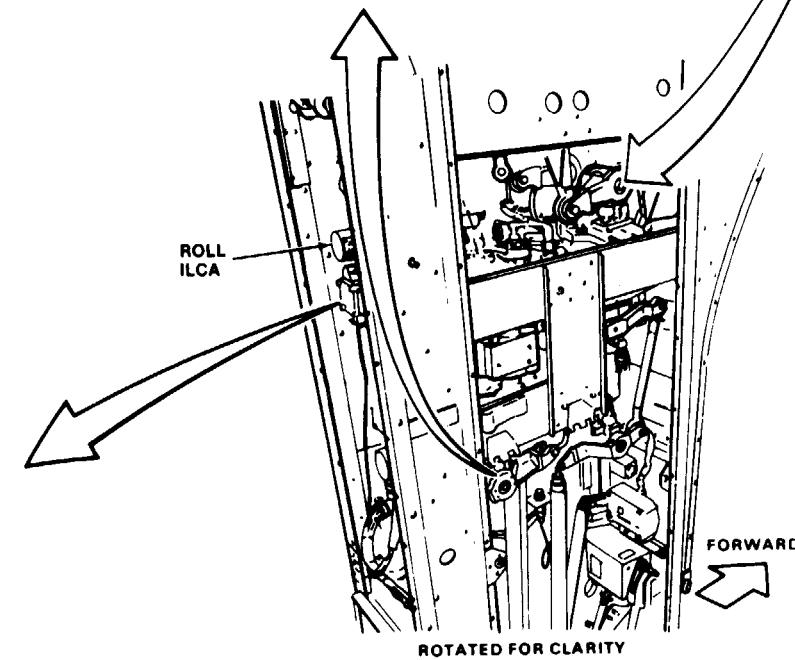
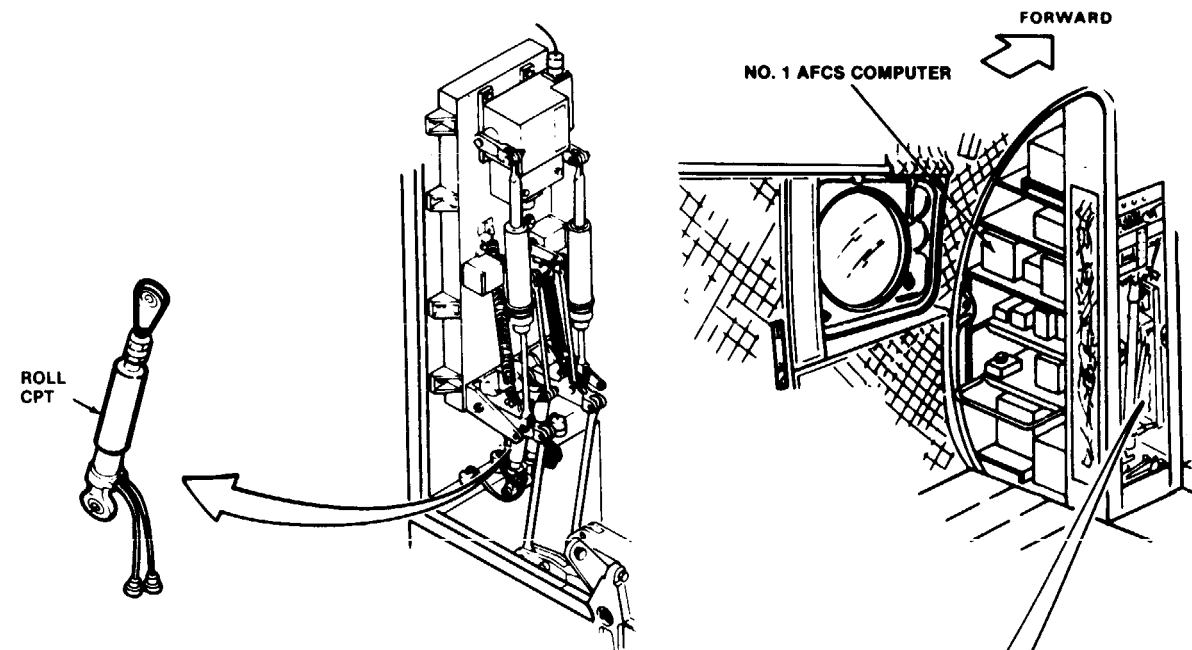
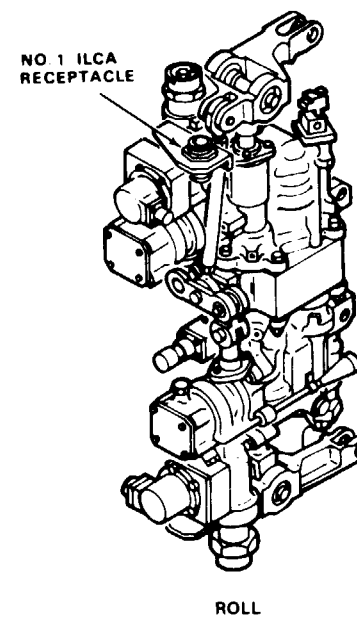
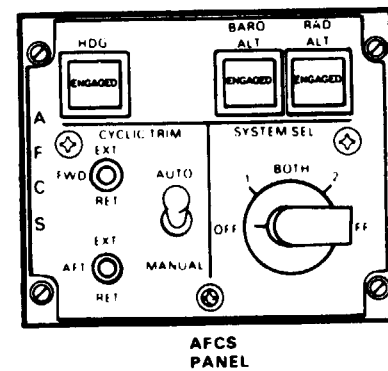
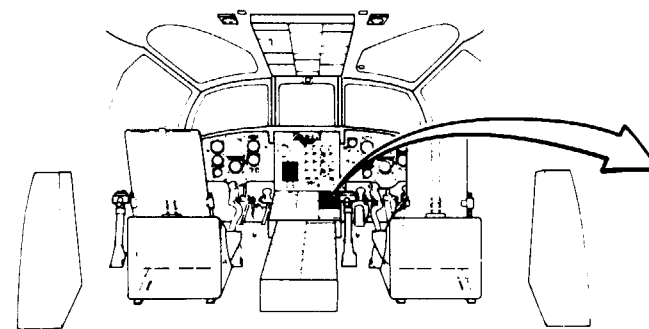

11-3.23 NO. 1 ROLL ILCA DOES NOT EXTEND OR RETRACT WITH LATERAL STICK MOTION (Continued)

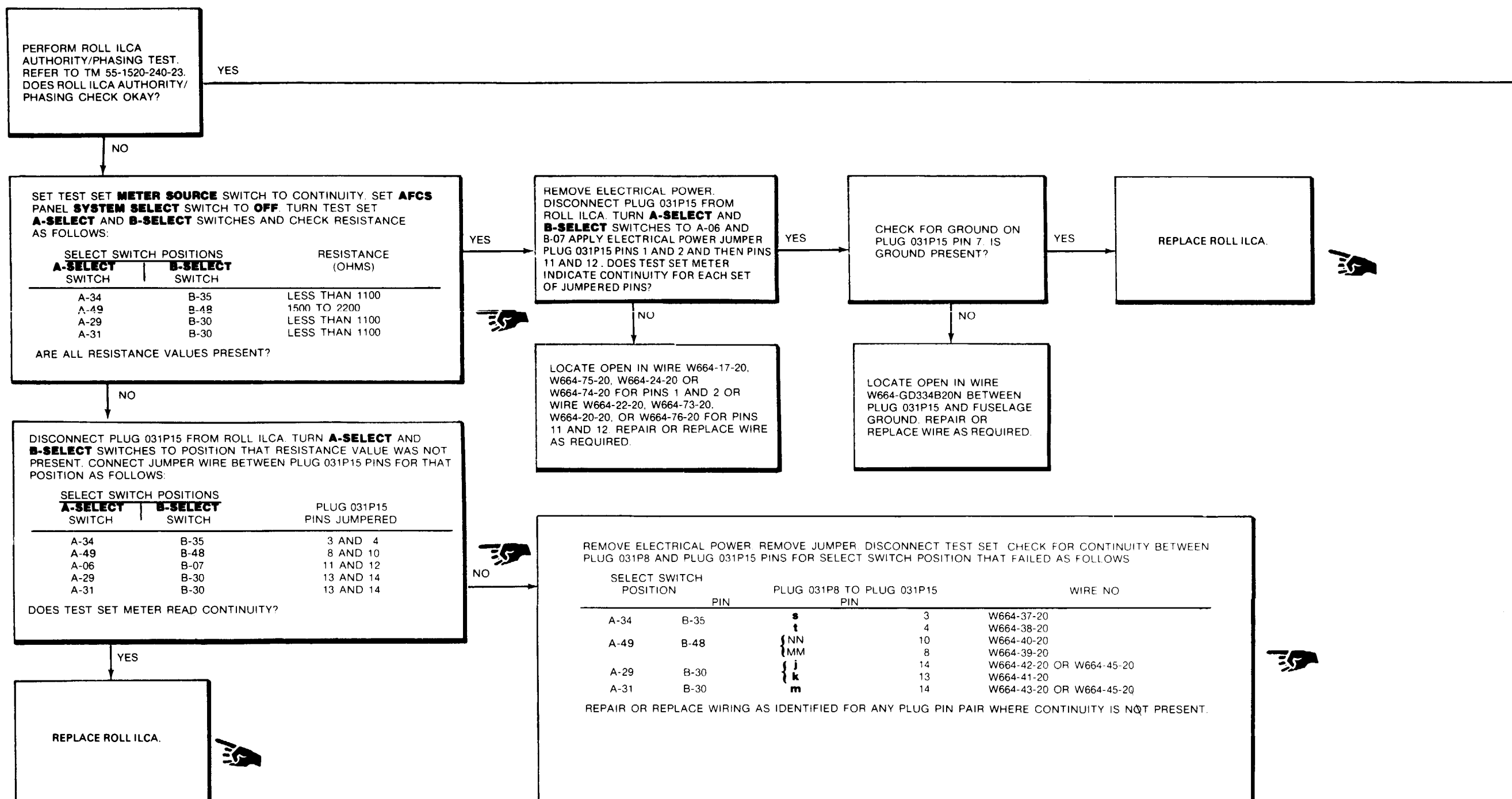

GO TO NEXT PAGE

11-3.23 NO. 1 ROLL ILCA DOES NOT EXTEND OR RETRACT WITH LATERAL STICK MOTION (Continued)

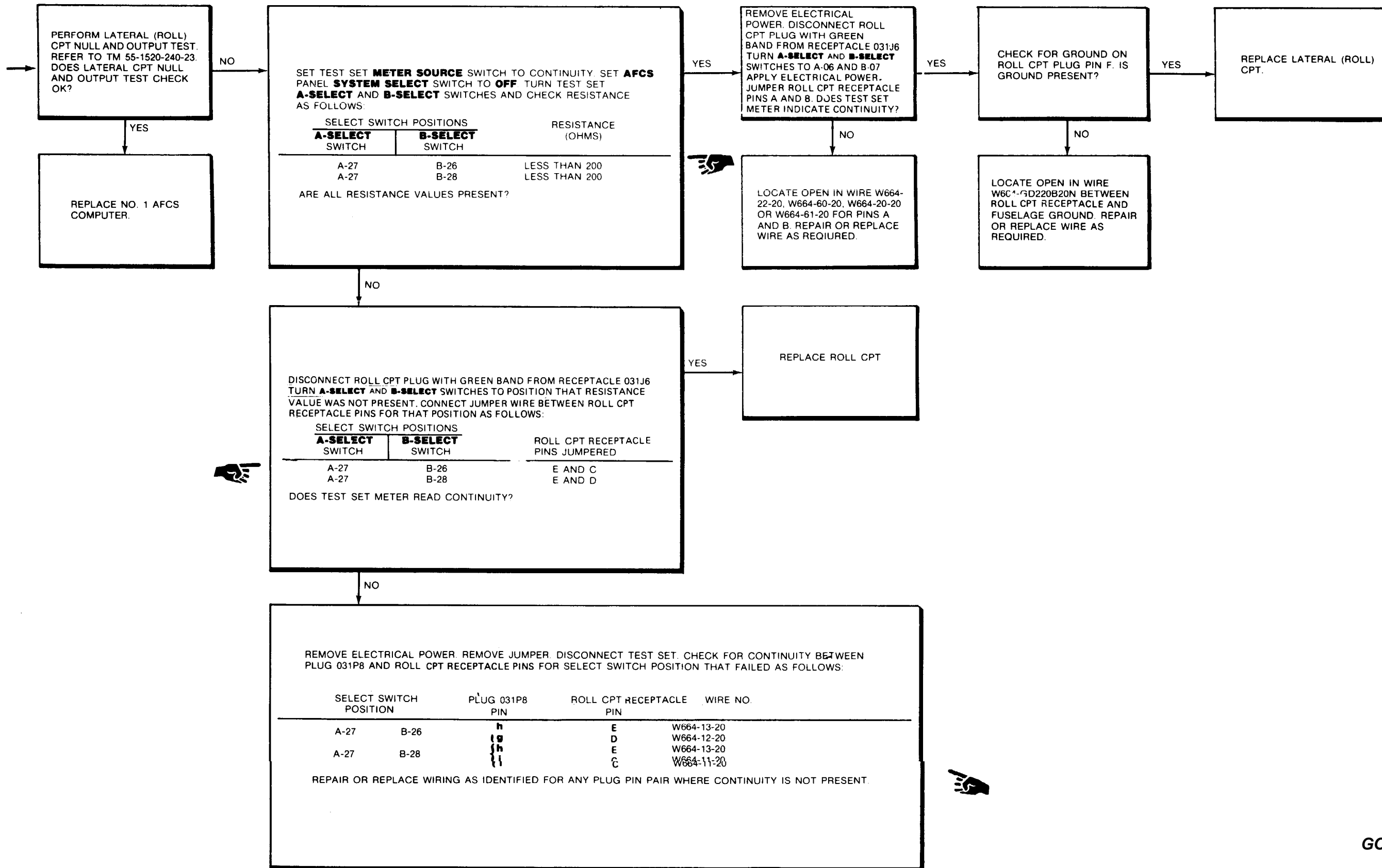

11-3.23 NO. 1 ROLL ILCA DOES NOT EXTEND OR RETRACT WITH LATERAL STICK MOTION (Continued)

11-3.23

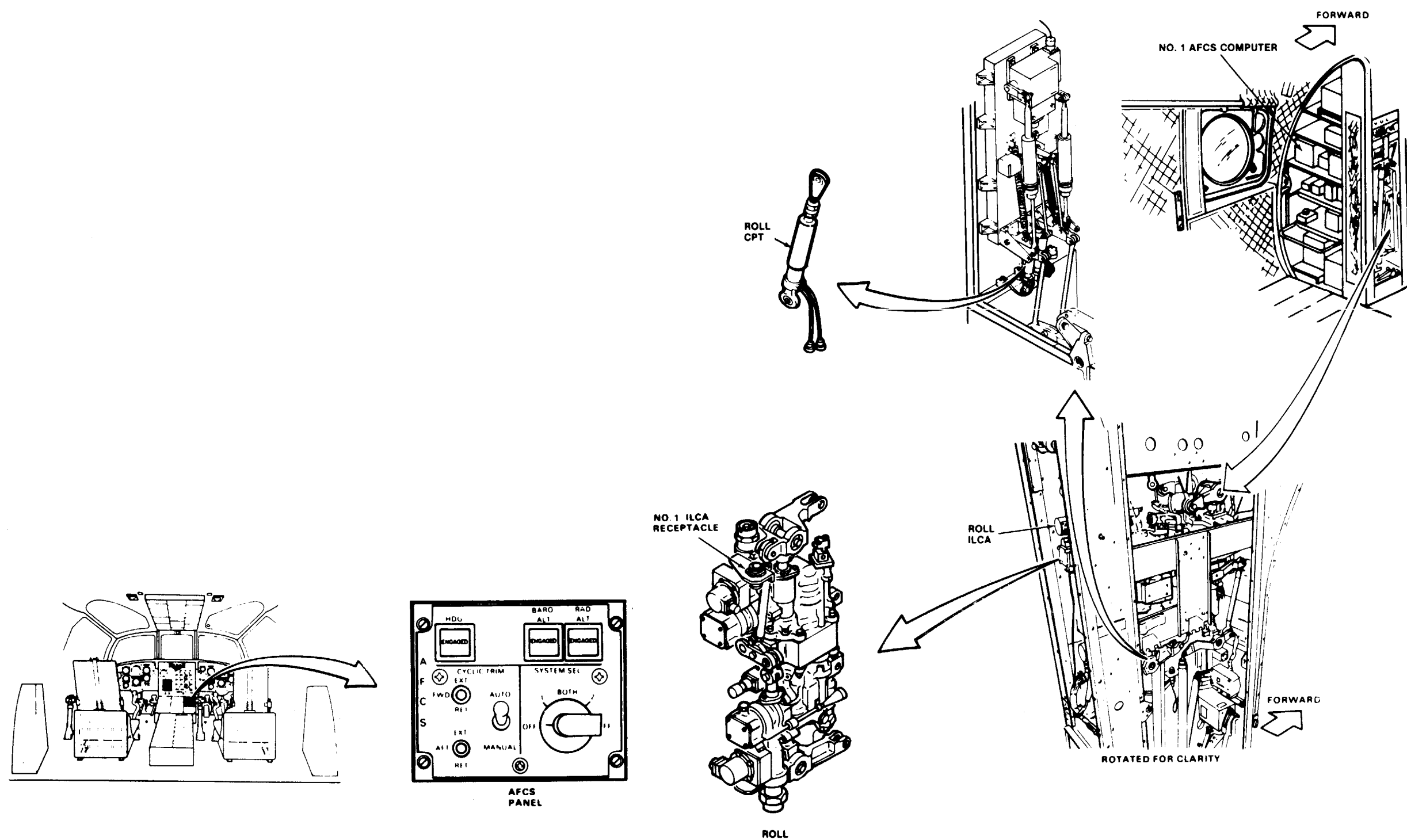

90-54

D145-12376-SPA

END OF TASK

11-3.24 NO. 1 ROLL ILCA DOES NOT MOVE WHEN PILOT'S OR COPILOT'S PITCH AND ROLL TRIM SWITCH MOVED RIGHT OR LEFT

FAULT ISOLATION PROCEDURE

INITIAL SETUP

Applicable Configurations:

- Electrical Repairer's Tool Kit,
NSN 5180-00-323-4915
- Multimeter

Materials:

None

Personnel Required:
Avionic Mechanic (2)

References:
TM 55-1520-240-23

Equipment Condition:
TM 55-1520-240-23
Battery Connected
Electrical Power On
Hydraulic Power On

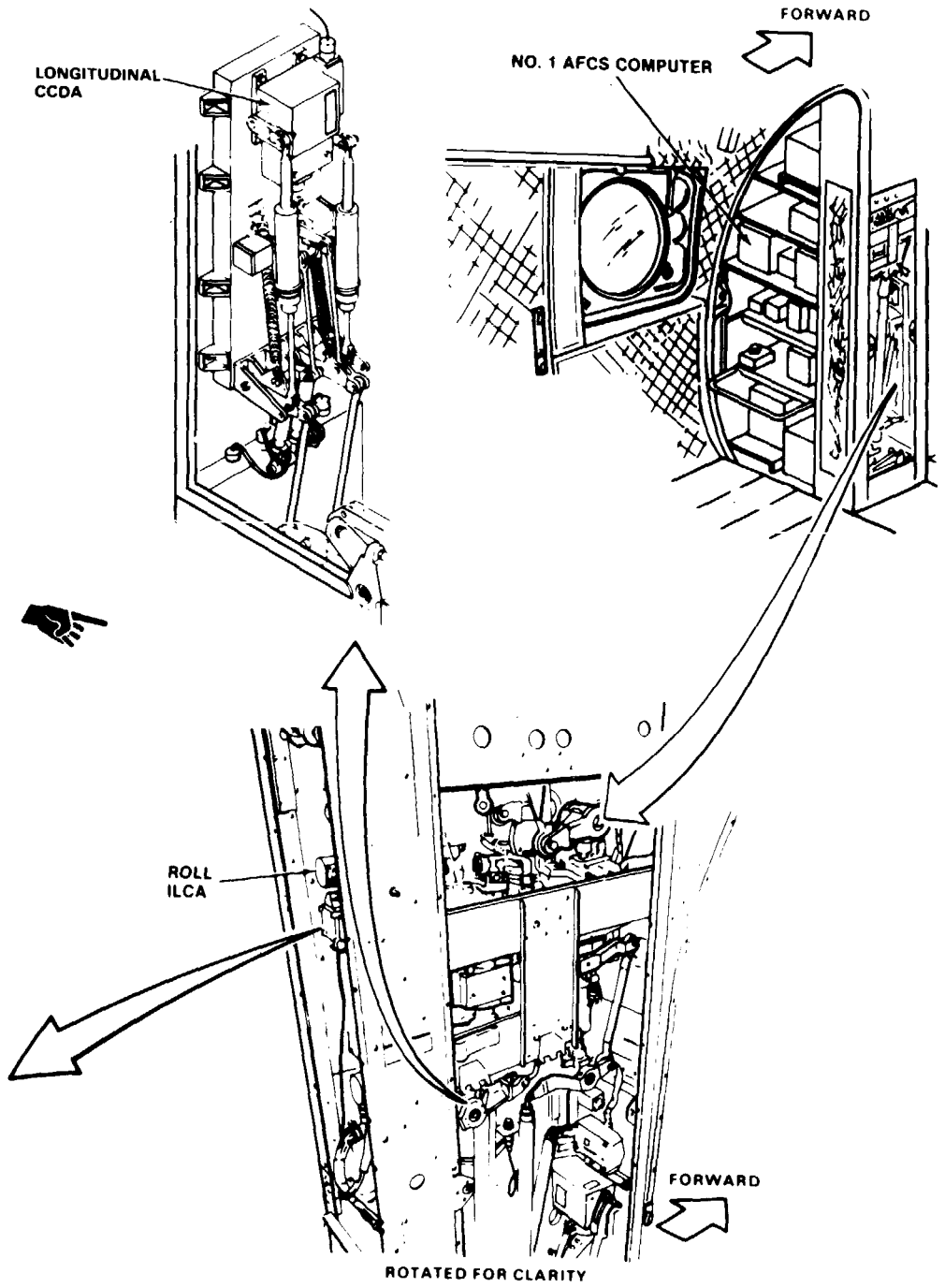
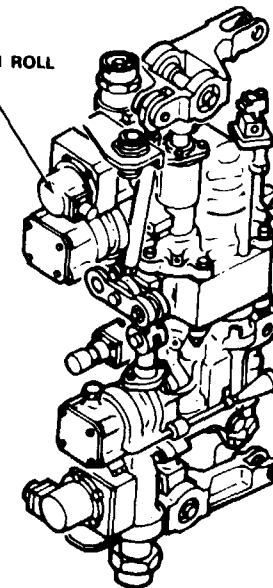
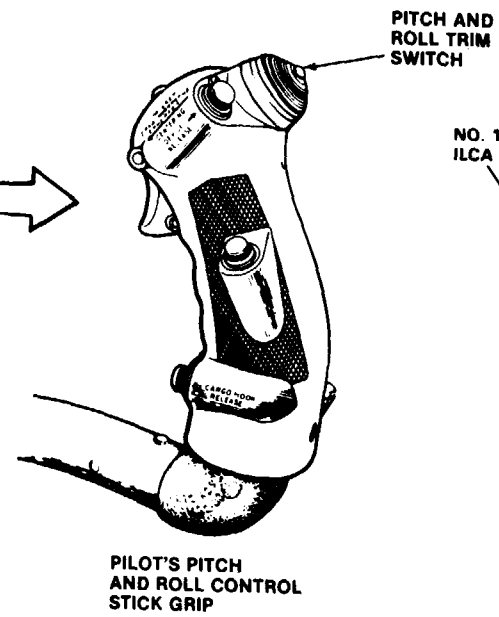
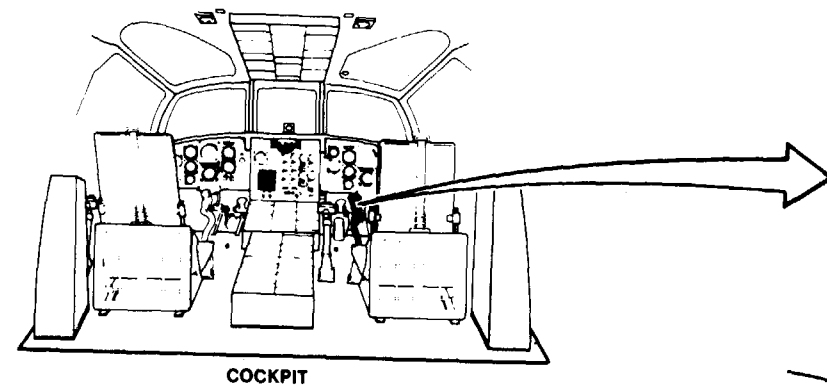

90 X 5 4

911

D145-11904-SPA

GO TO NEXT PAGE

11-3.24 NO. 1 ROLL ILCA DOES NOT MOVE WHEN PILOT'S OR COPILOT'S PITCH AND ROLL TRIM SWITCH MOVED RIGHT OR LEFT (Continued)

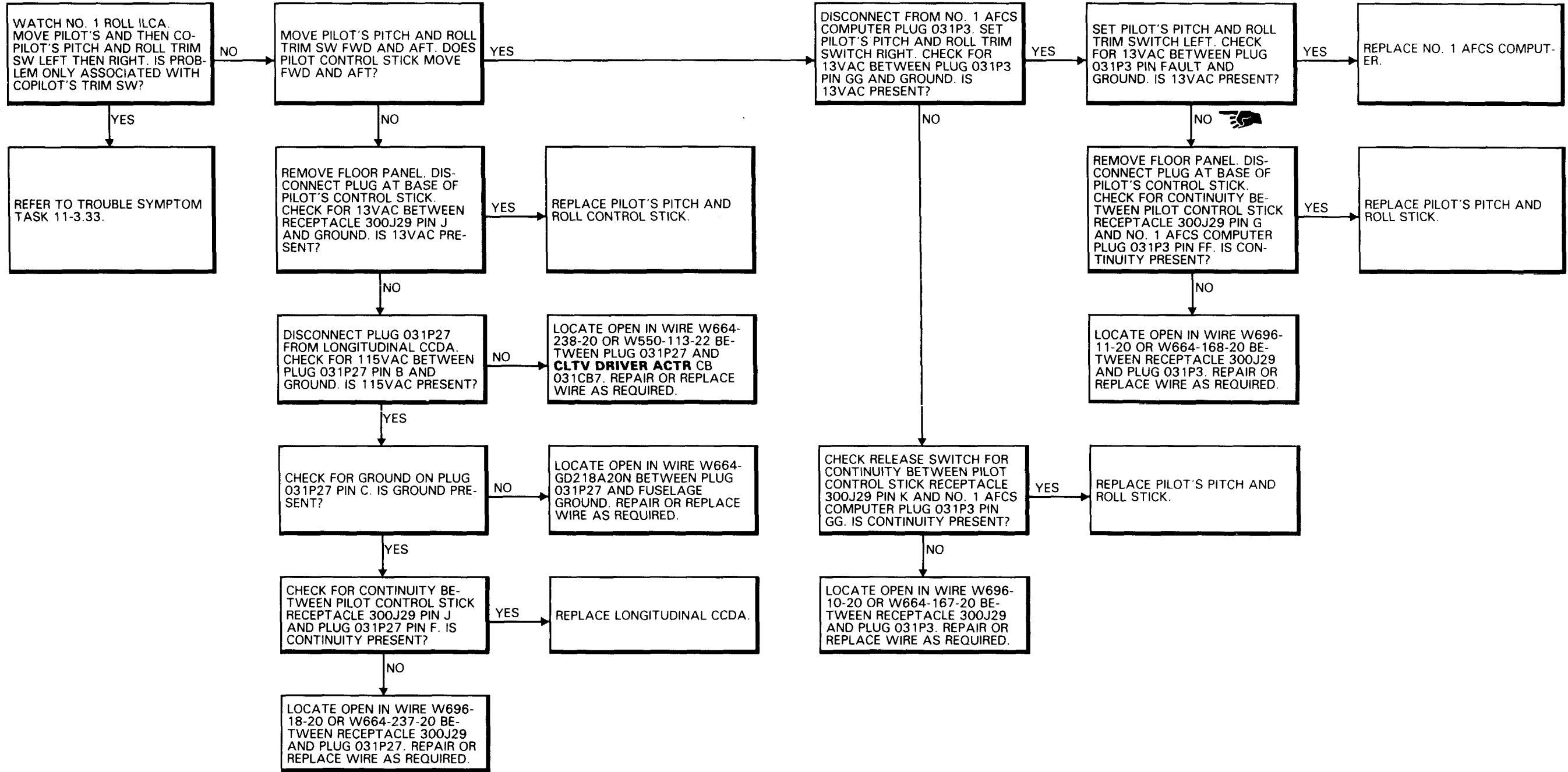

11-3.25 AFCS BITE OPERATES WITH ENQINK CONDITION LEVER IN FLIGHT POSITION

FAULT ISOLATION PROCEDURE

INITIAL SETUP

Applicable Configurations:

All

Tools:

Electrical Repairer's Tool Kit,
NSN 5180-00-323-4915
Multimeter

Materials:

None

Personnel Required:

35K10 Avionic Mechanic
33K20 Avionic Mechanic

References:

TM 55-1520-240-23

Equipment Condition:

TM 55-1520-240-23
Battery Connected
Electrical Power On
Hydraulic Power On

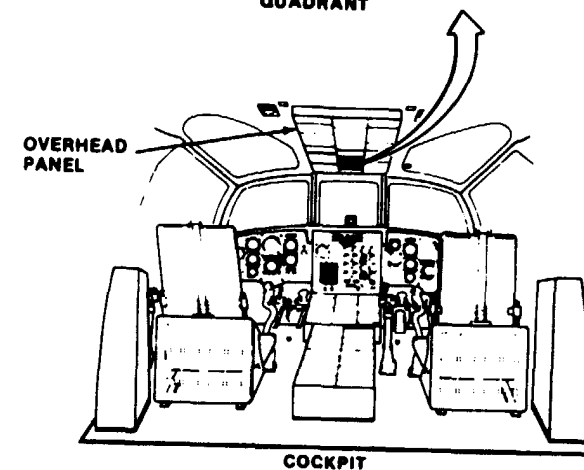
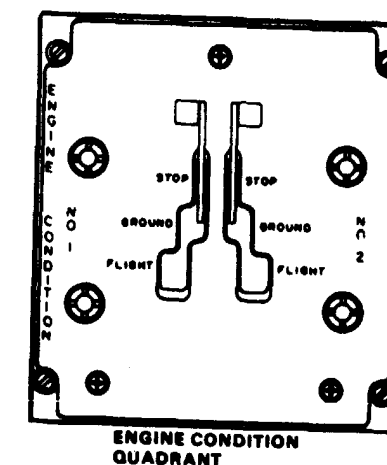
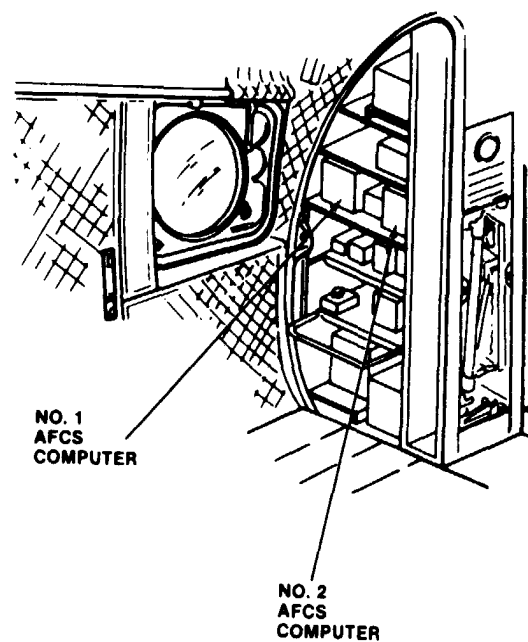

90 X 54

D146-11833-3PA

GO TO NEXT PAGE

11-3.25 AFCS BITE OPERATES WITH ENGINE CONDITION LEVER IN FLIGHT POSITION (Continued)

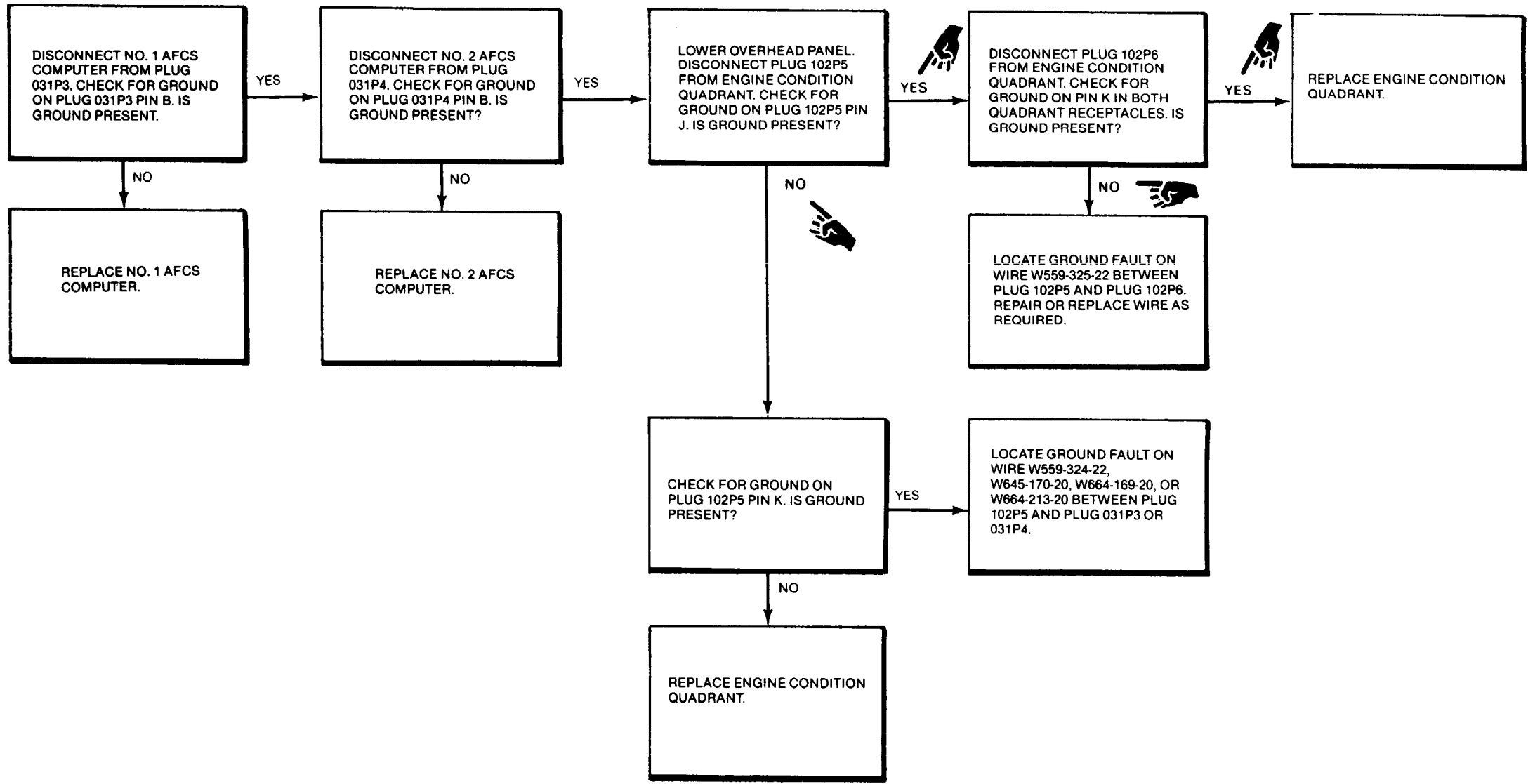

11-3.26 NO. 1 AFCS COMPUTER BITE SWITCH DOES NOT LIGHT AND
COUNTER DOES NOT STEP WHEN BITE SWITCH IS PRESSED AND
RELEASED

FAULT ISOLUTION PROCEDURE

INITIAL SETUP

Personnel Required

- 35K10 Avionic Mechanic
- 35K20 Avionic Mechanic

Applicable Configurations:

All

References:

TM 55-1520-240-23

Tools:

- Electrical Repairer's Tool Kit,
NSN 5180-00-323-4915
- Multimeter

Equipment Condition:

TM 55-1520-240-23

Materials:

None

- Battery Disconnected
- Electrical Power Off
- Hydraulic Power Off

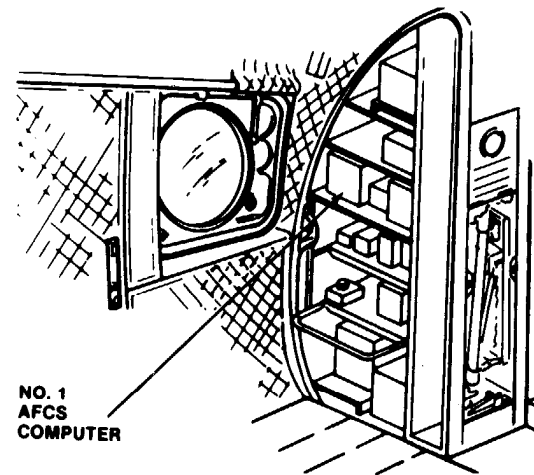

NO. 1
AFCS
COMPUTER

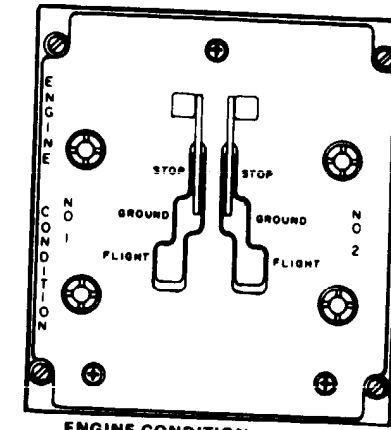

ENGINE CONDITION
QUADRANT

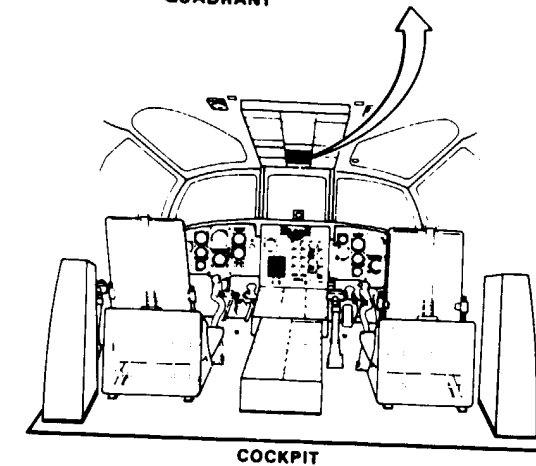

COCKPIT

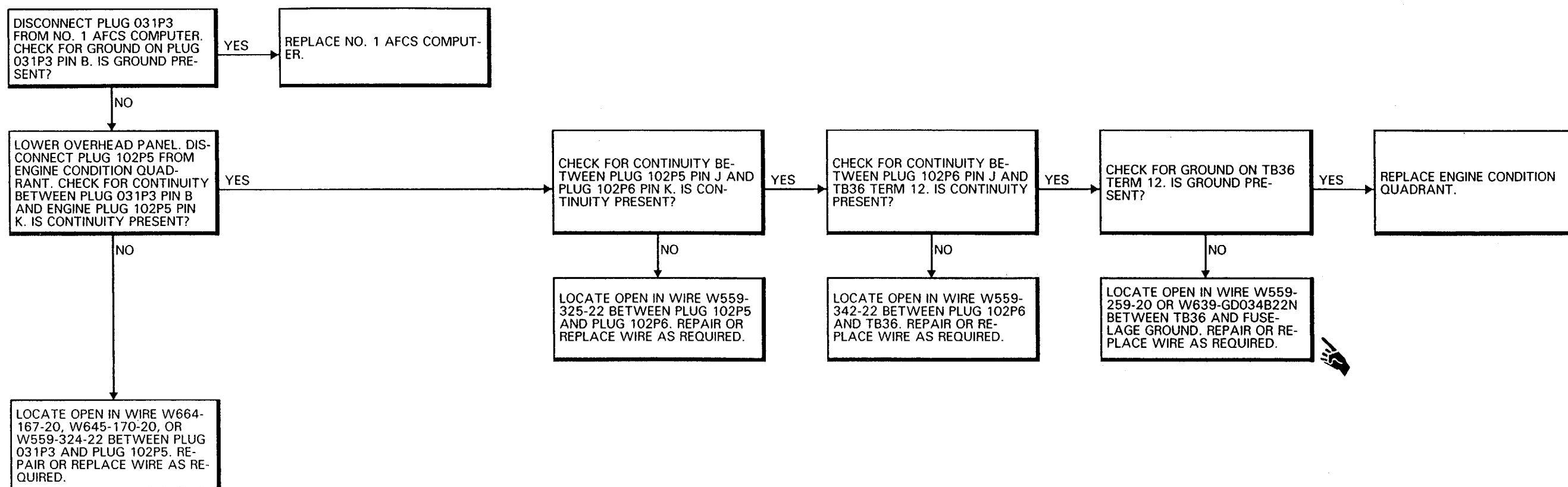

11-3.27 NO. 2 AFCS OFF (WITHOUT 74) OR AFCS 2 (WITH 74) CAPSULE DOES NOT GO OUT WHEN SYSTEM SELECTED

FAULT ISOLATION PROCEDURE

INITIAL SETUP

Applicable Configurations:

All

Tools:

- Electrical Repairer's Tool Kit,
NSN 5180-00-323-4915
- Multimeter

Materials:

None

Personnel Required:

Avionic Mechanic (2)

References:

- TM 55-1520-240-23
- TM 11-1520-240-23

Equipment Condition:

- TM 55-1520-240-23:
- Battery Connected
- Electrical Power On
- Hydraulic Power On

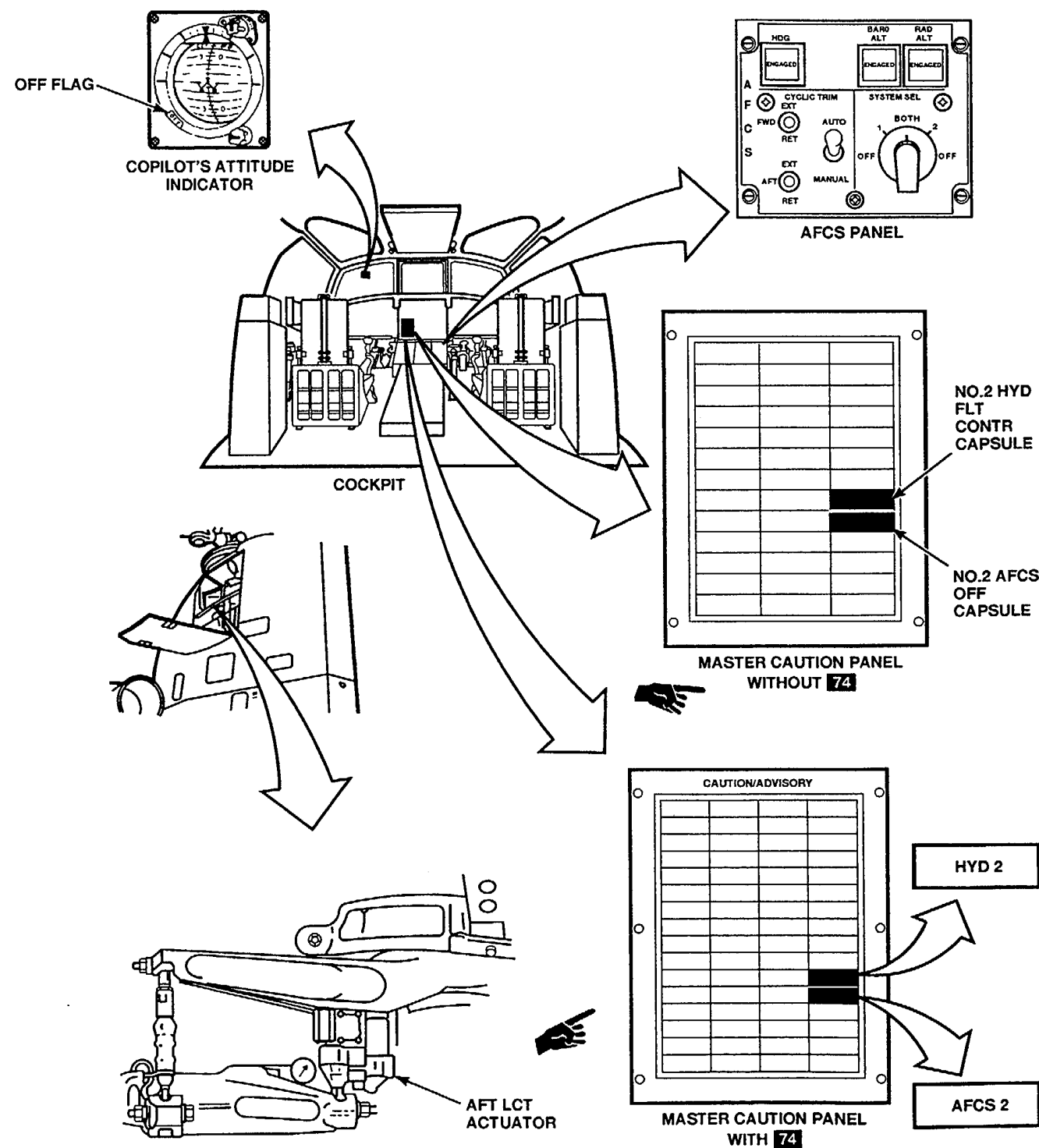
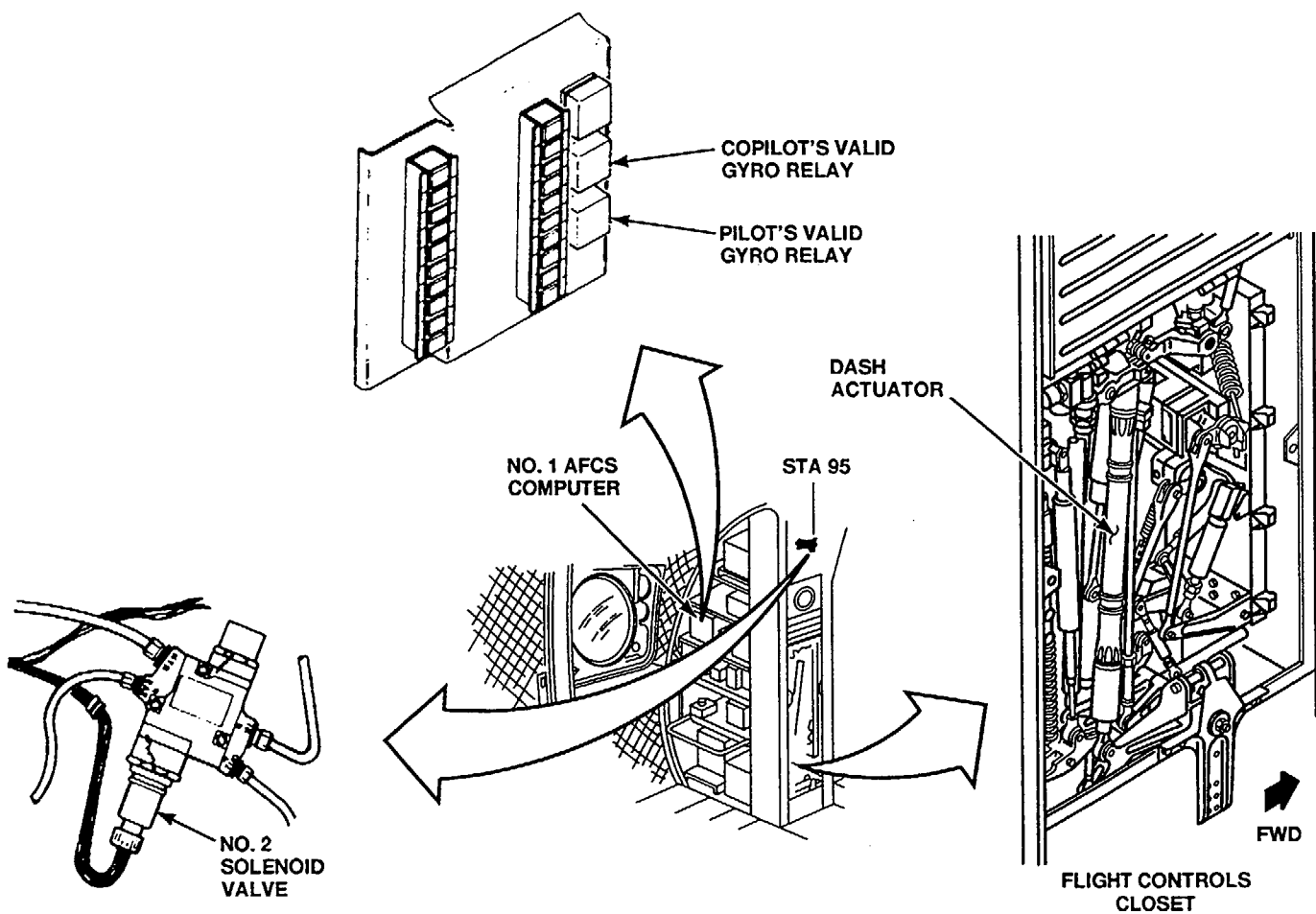

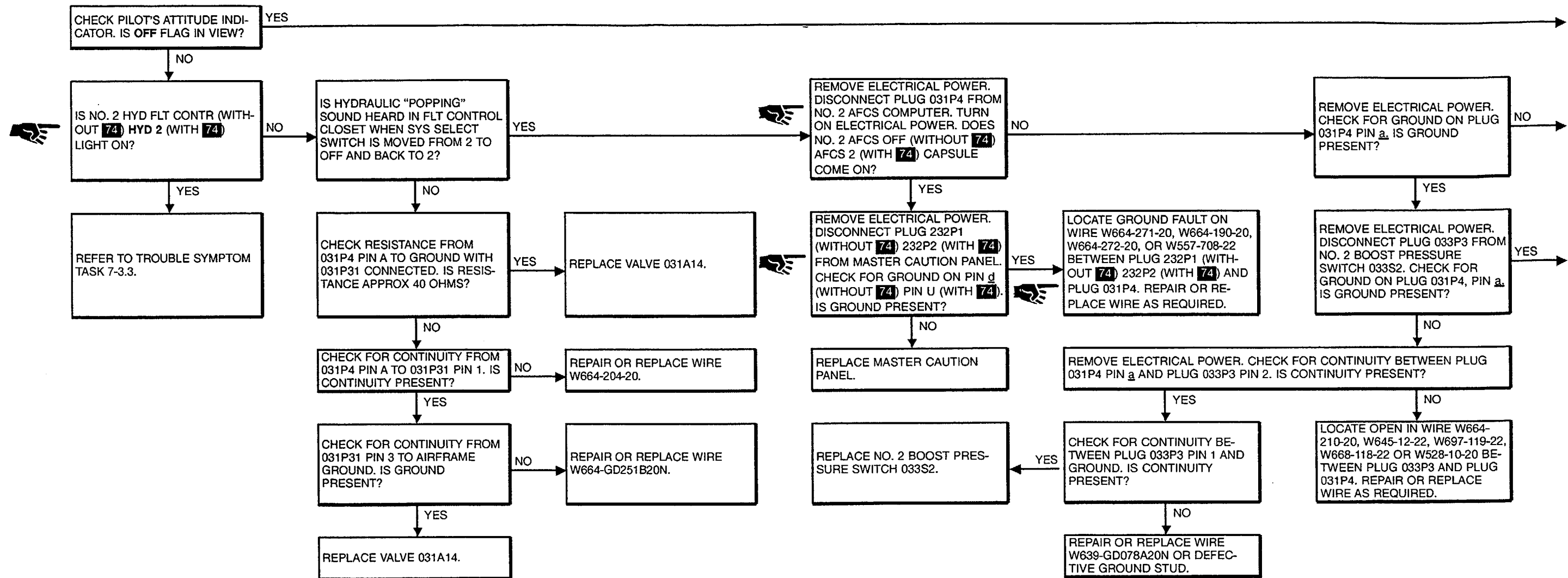

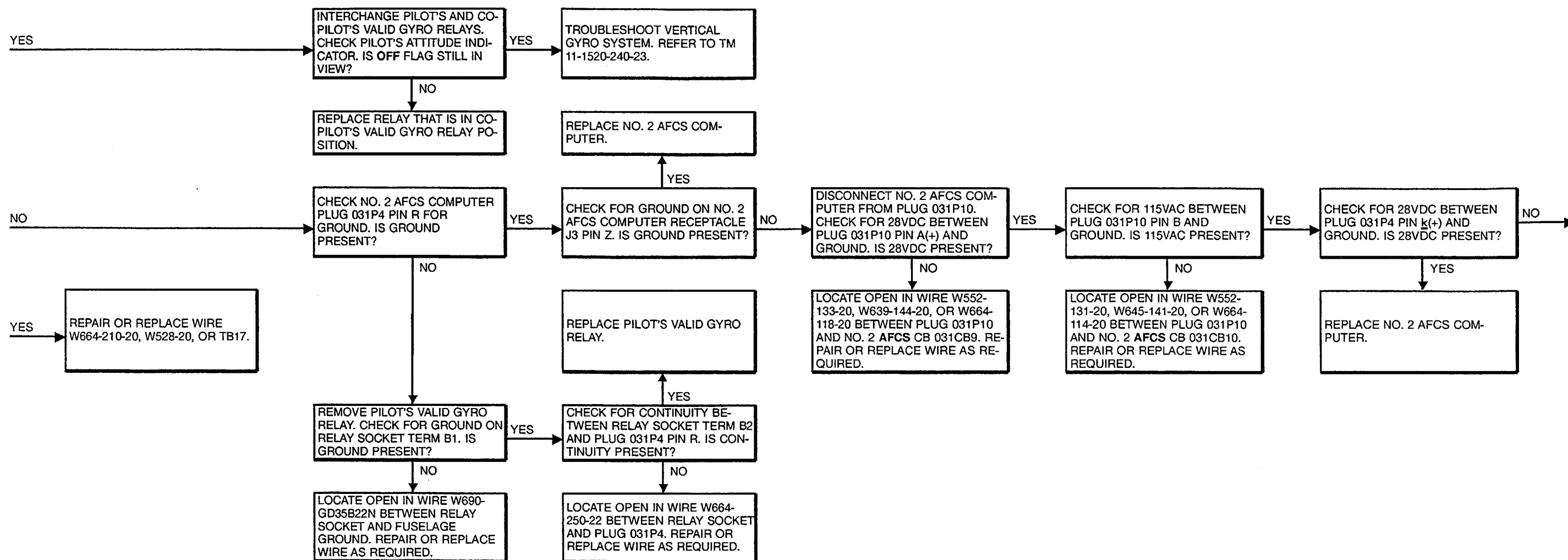

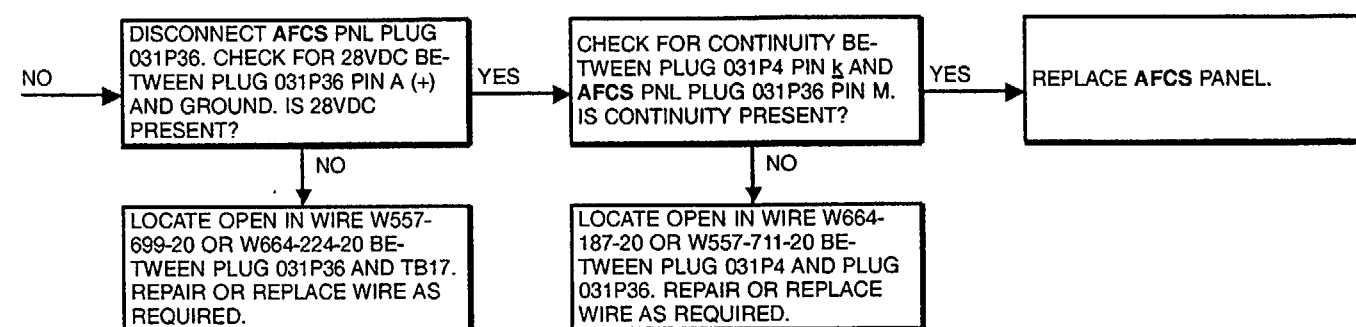

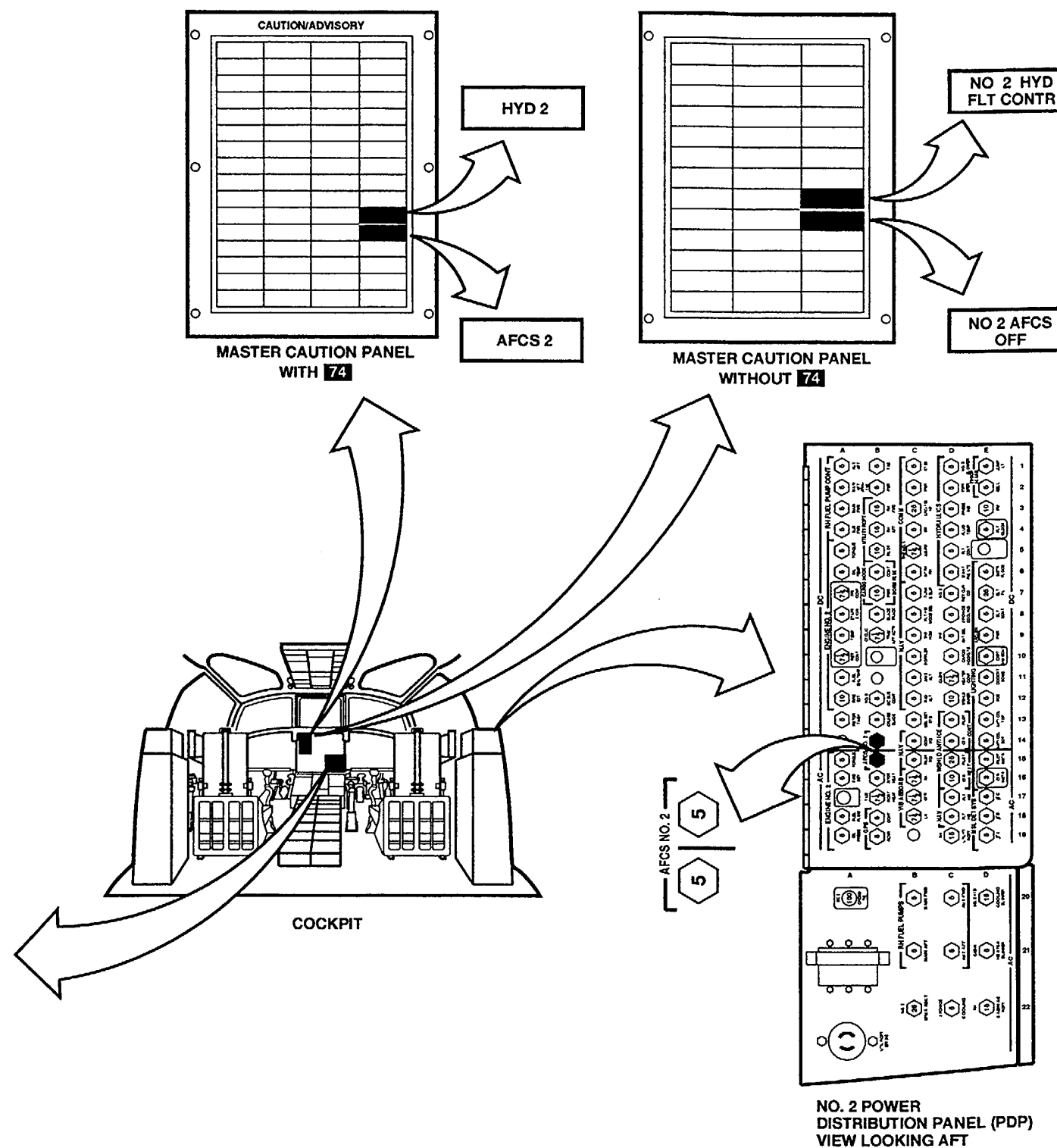
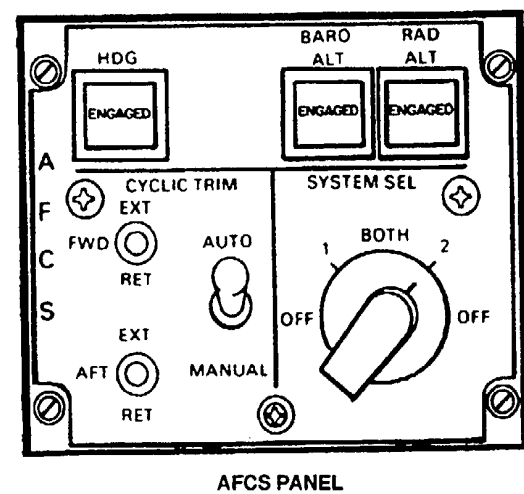
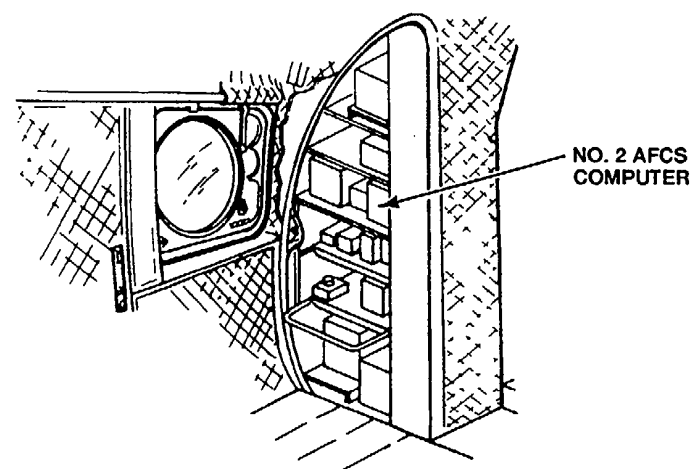

11-3.27 NO. 2 AFCS OFF CAPSULE DOES NOT GO OUT WHEN SYSTEM SELECTED (Continued)

11-3.27

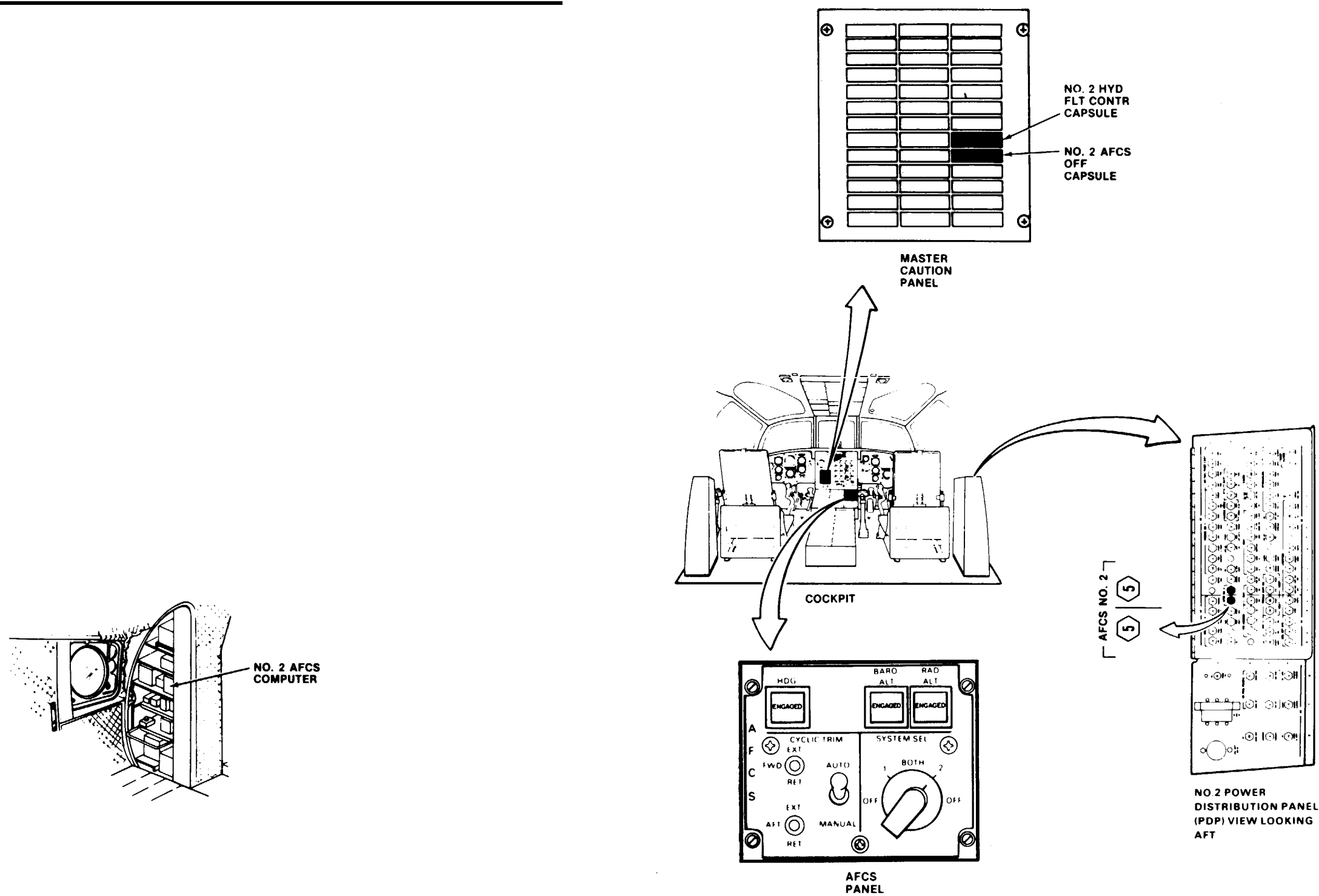

90X54

D145-11928-SPA

END OF TASK

FAULT ISOLATION PROCEDURE

INITIAL SETUP

Applicable Configurations:
All

Tools:
Electrical Repairer's Tool Kit,
NSN 5180-00-323-4915
Multimeter

Materials:
None

Personnel Required:
35K10 Avionic Mechanic
35K20 Avionic Mechanic

References:

TM 55-1520-240-23

TM 55-4920-429-13

Equipment Condition:

TM 55-1520-240-23

Battery Connected

Electrical Power On

Hydraulic Power On

TM 55-4920-429-13

AFCS Line Test Set 145G0009-1

Prepared For Use

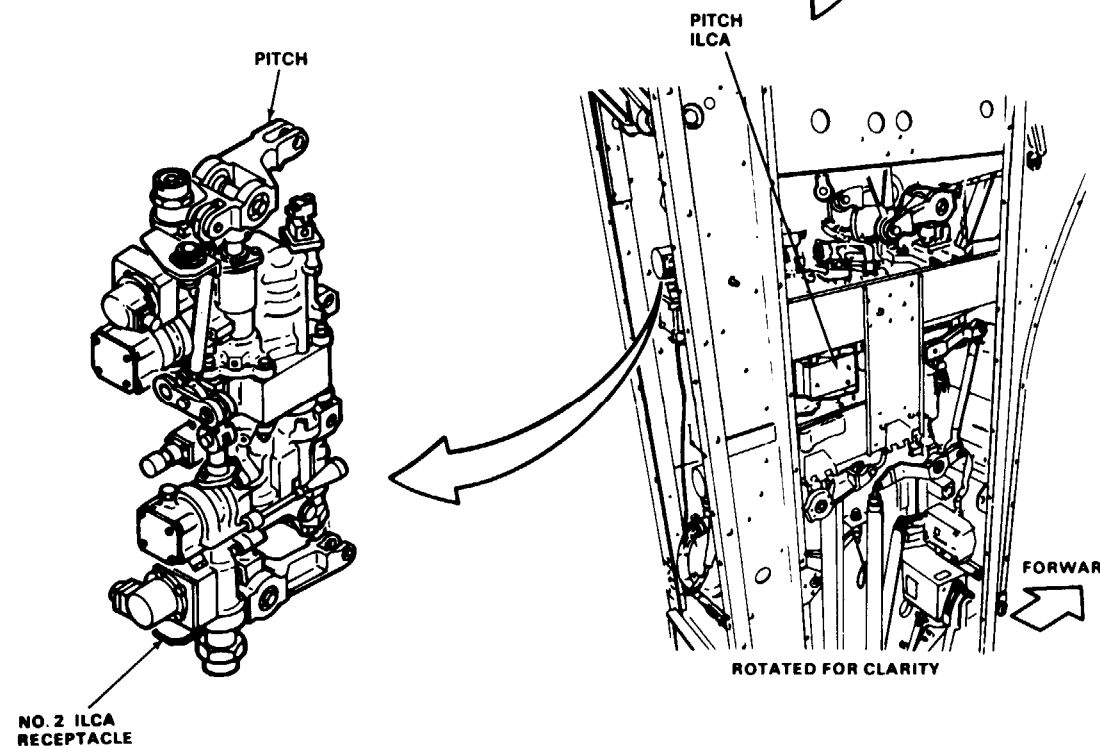
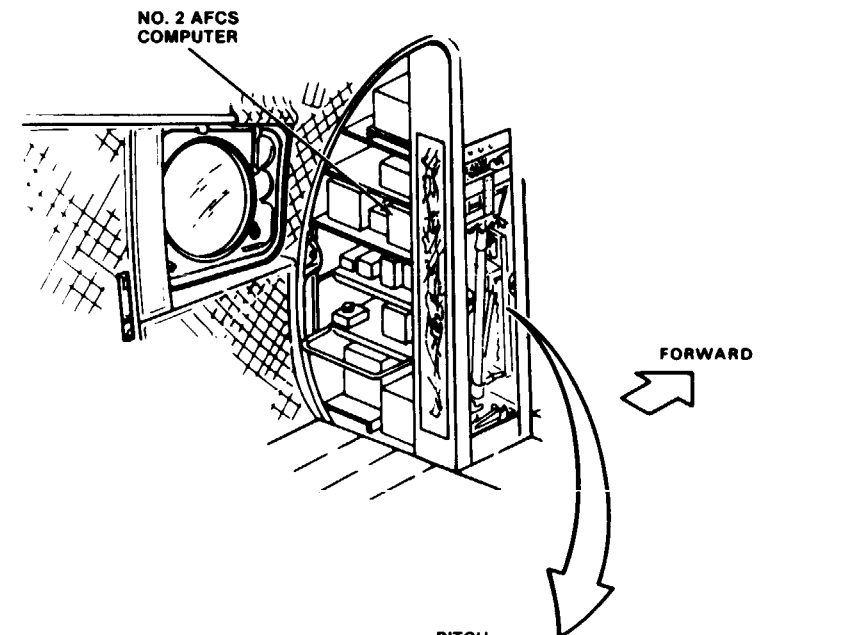
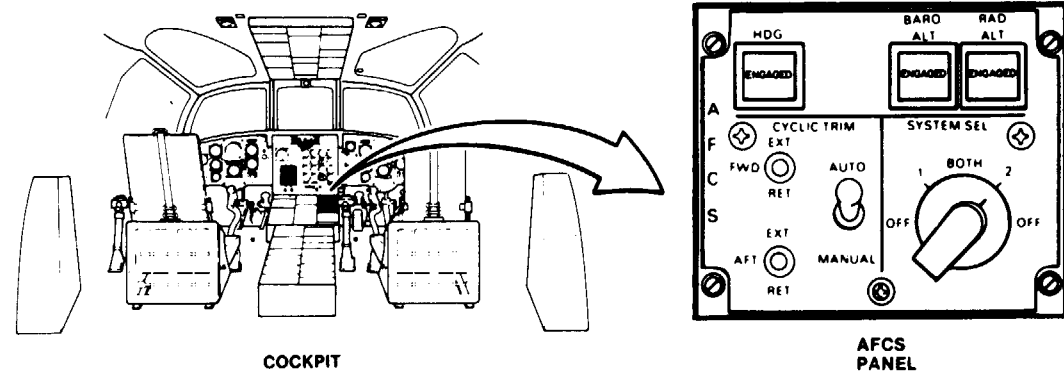

90x54

D145-11955-SPA

11-3.28 NO. 2 PITCH ILCA HAS ENGAGE TRANSIENT (Continued)

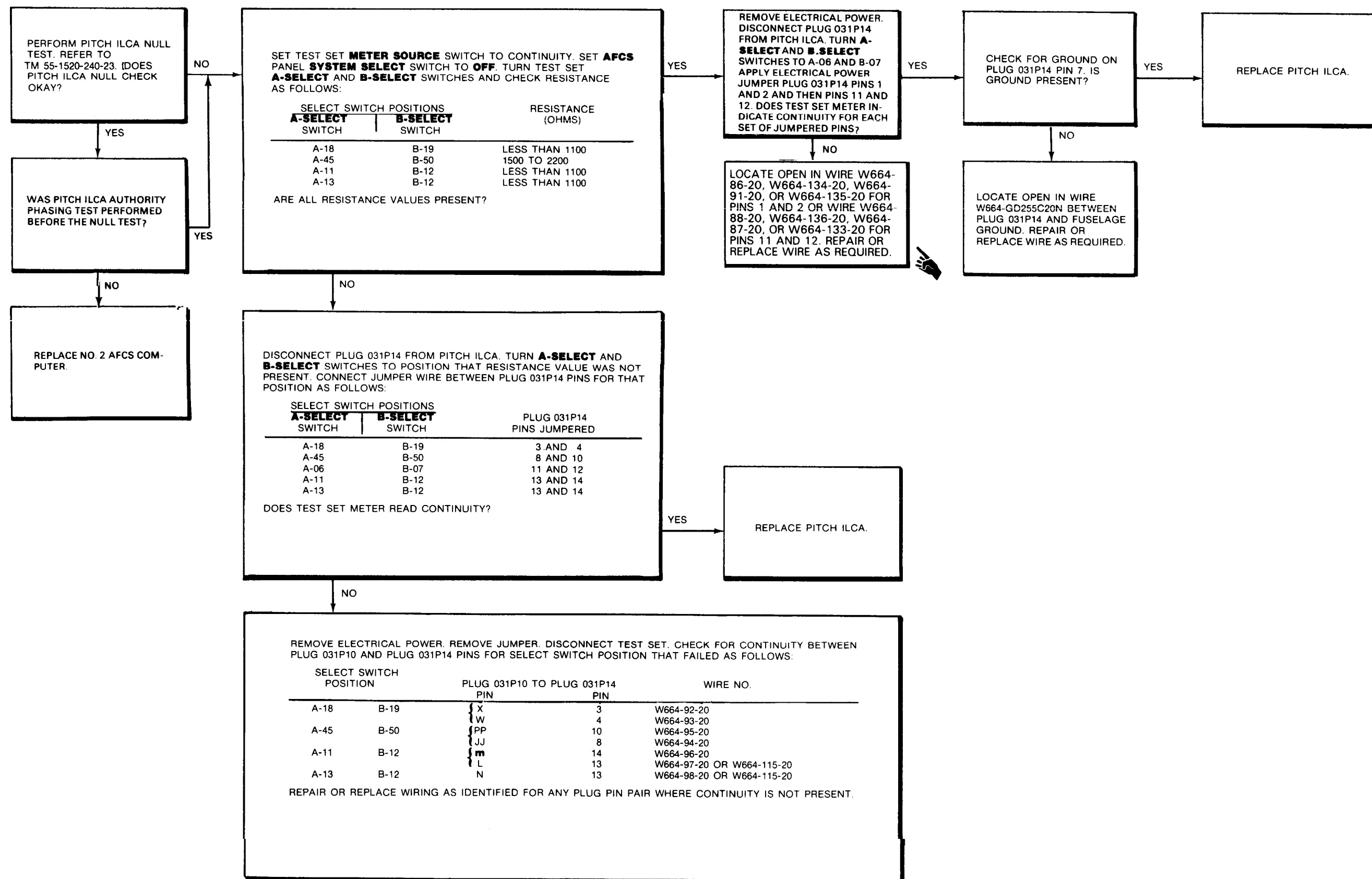

END OF TASK

FAULT ISOLATION PROCEDURE

INITIAL SETUP

Applicable Configurations:
All

Tools:

- Electrical Repairer's Tool Kit,
NSN 5180-00-323-4915
- Multimeter

Materials:

None

Personnel Required:

- 35K10 Avionic Mechanic
- 35K20 Avionic Mechanic

References:

- TM 55-1520-240-23
- TM 55-4920-429-13

Equipment Condition:

- TM 55-1520-240-23
- Battery Connected
- Electrical Power On
- Hydraulic Power On
- TM 55-4920-429-13
- AFCS Line Test Set 145G0009-1
- Prepared For Use

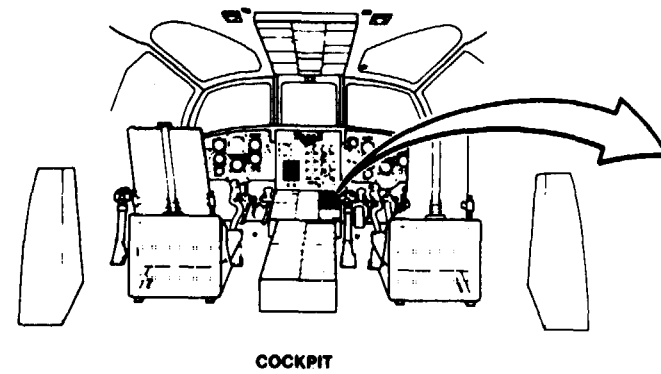

COCKPIT

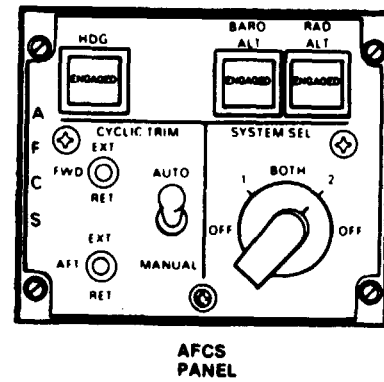

AFCS PANEL

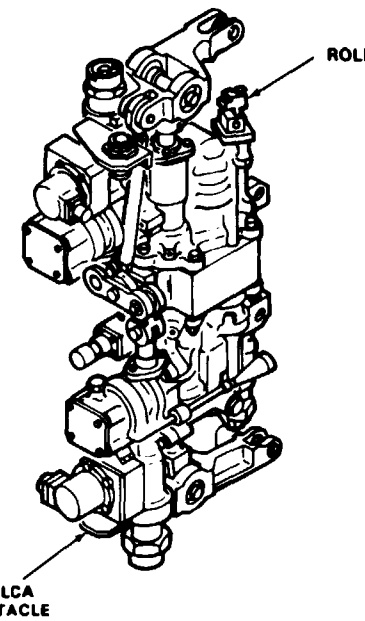
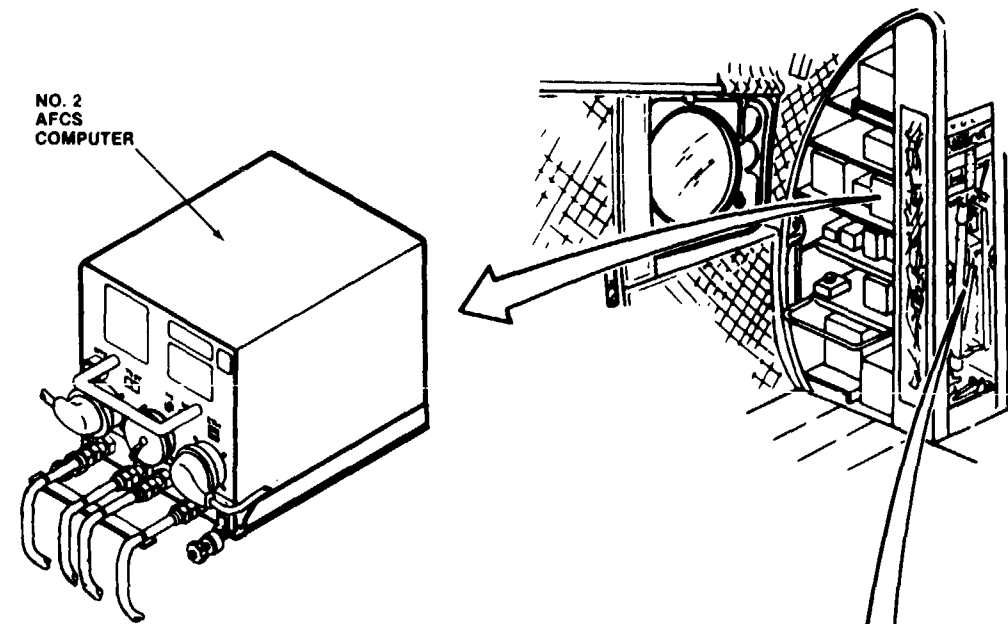

NO. 2 ILCA RECEPTACLE

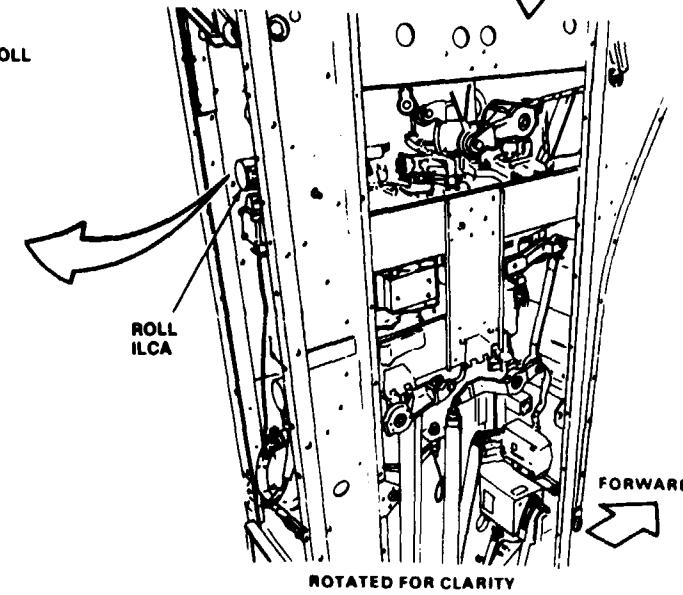

ROLL ILCA

ROTATED FOR CLARITY

11-3.29 NO. 2 ROLL ILCA HAS ENGAGE TRANSIENT (Continued)

11-3.29

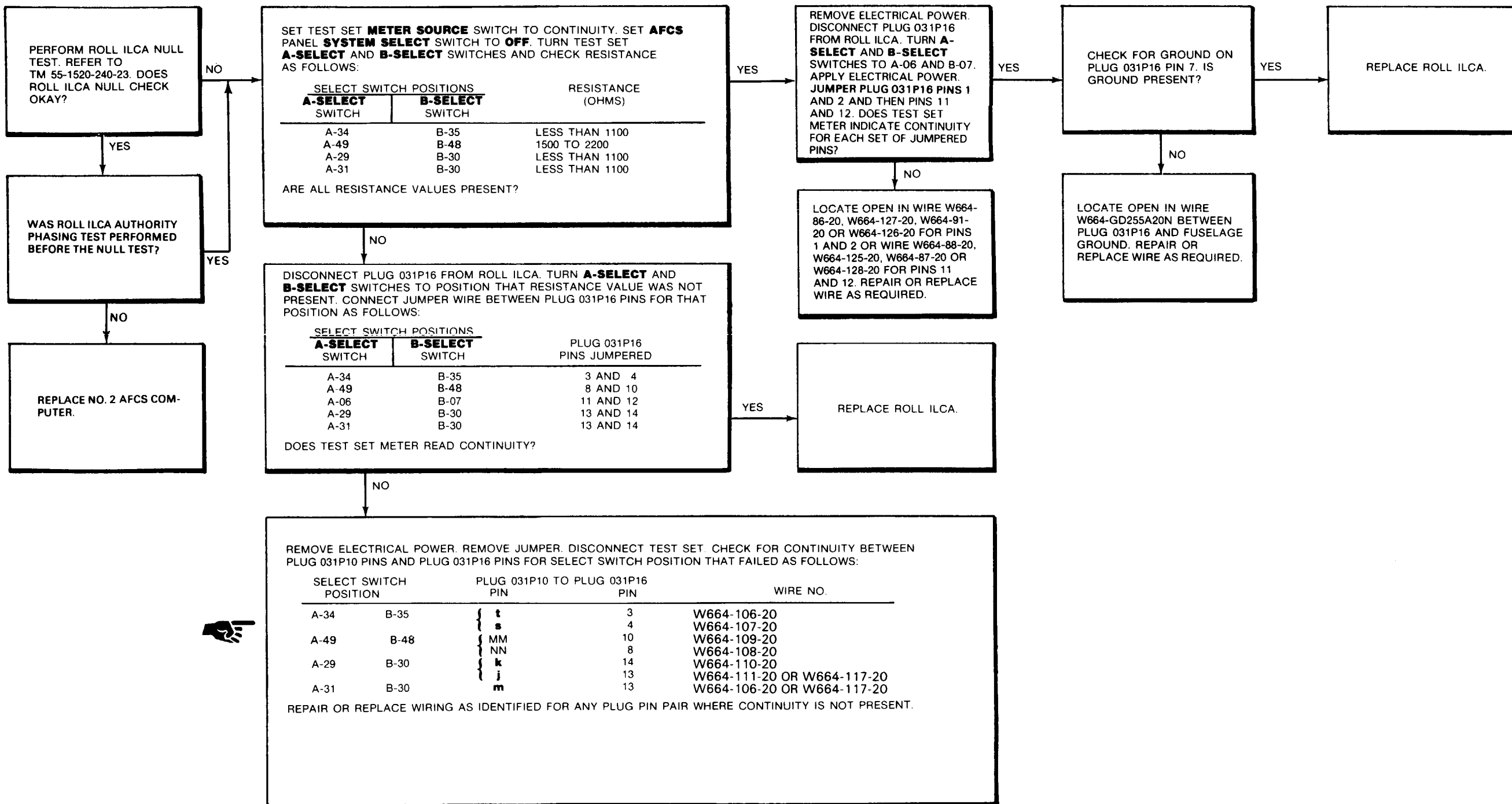

FAULT ISOLATION PROCEDURE

INITIAL SETUP

Applicable Configurations:

All

Tools:

Electrical Repairer's Tool Kit,
NSN 5180-00-323-4915
Multimeter

Materials:

None

Personnel Required

35K10 Avionic Mechanic
35K20 Avionic Mechanic

References:

TM 55-1520-240-23
TM 55-4920-429-13

Equipment Condition:

TM 55-1520-240-23
Battery Connected
Electrical Power On
Hydraulic Power On
TM 55-4920-429-13
AFCS Line Test Set 145G0009-1
Prepared for Use

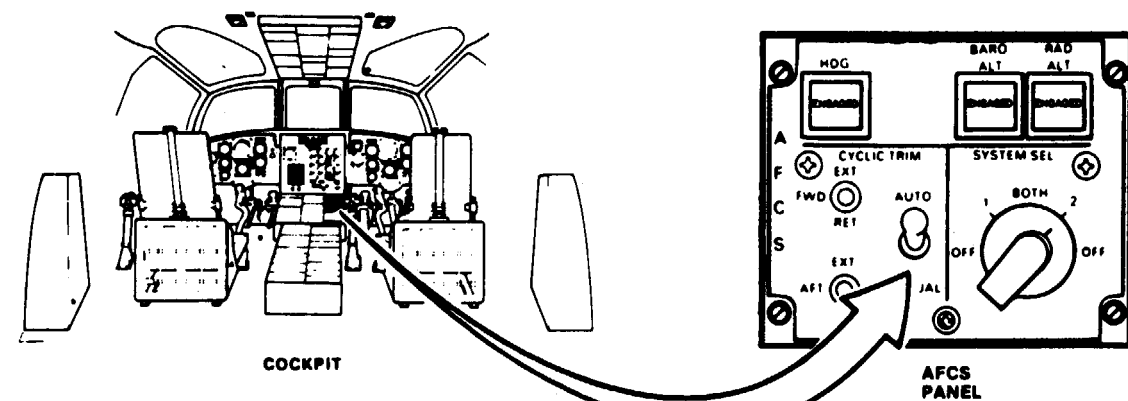

90154

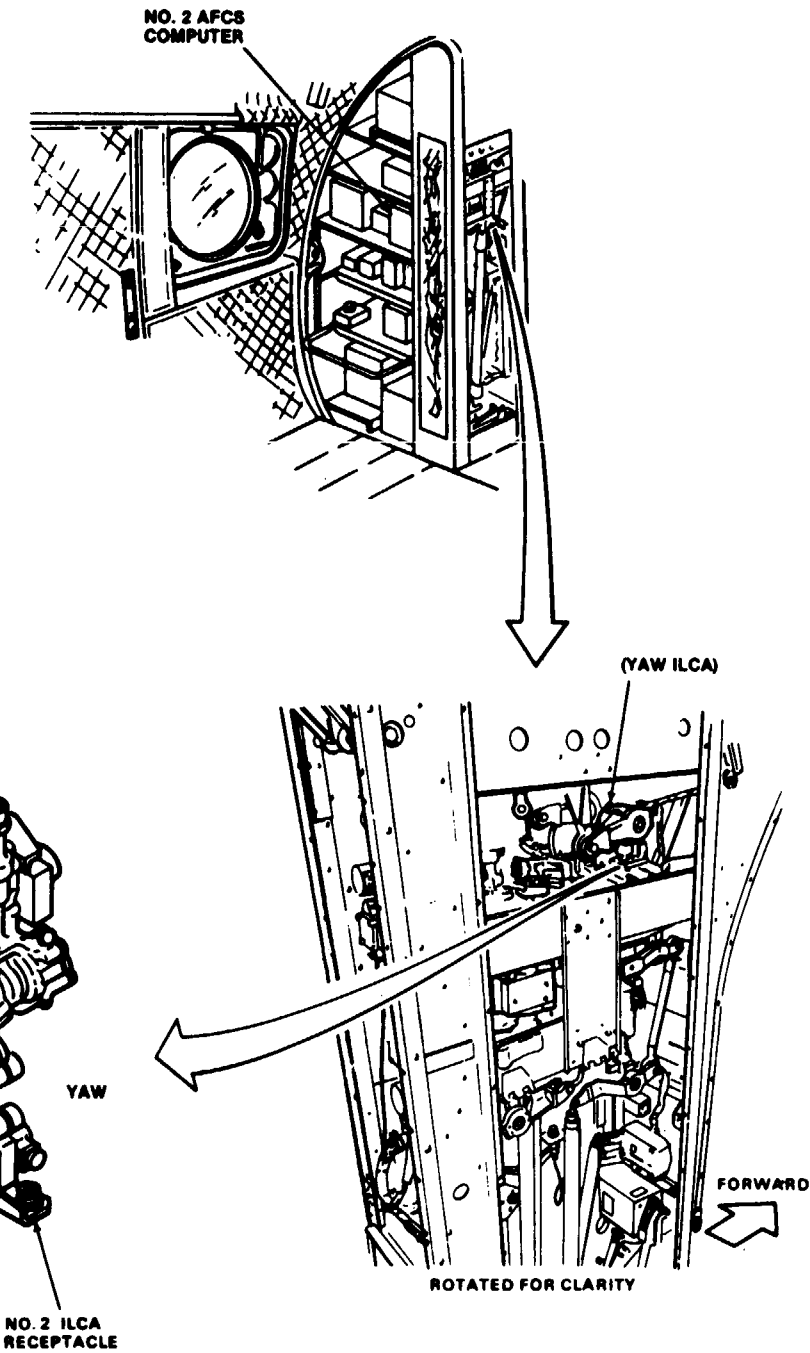

0145-11987-8PA

11-3.30 NO. 2 YAW ILCA HAS ENGAGE TRANSIENT (Continued)

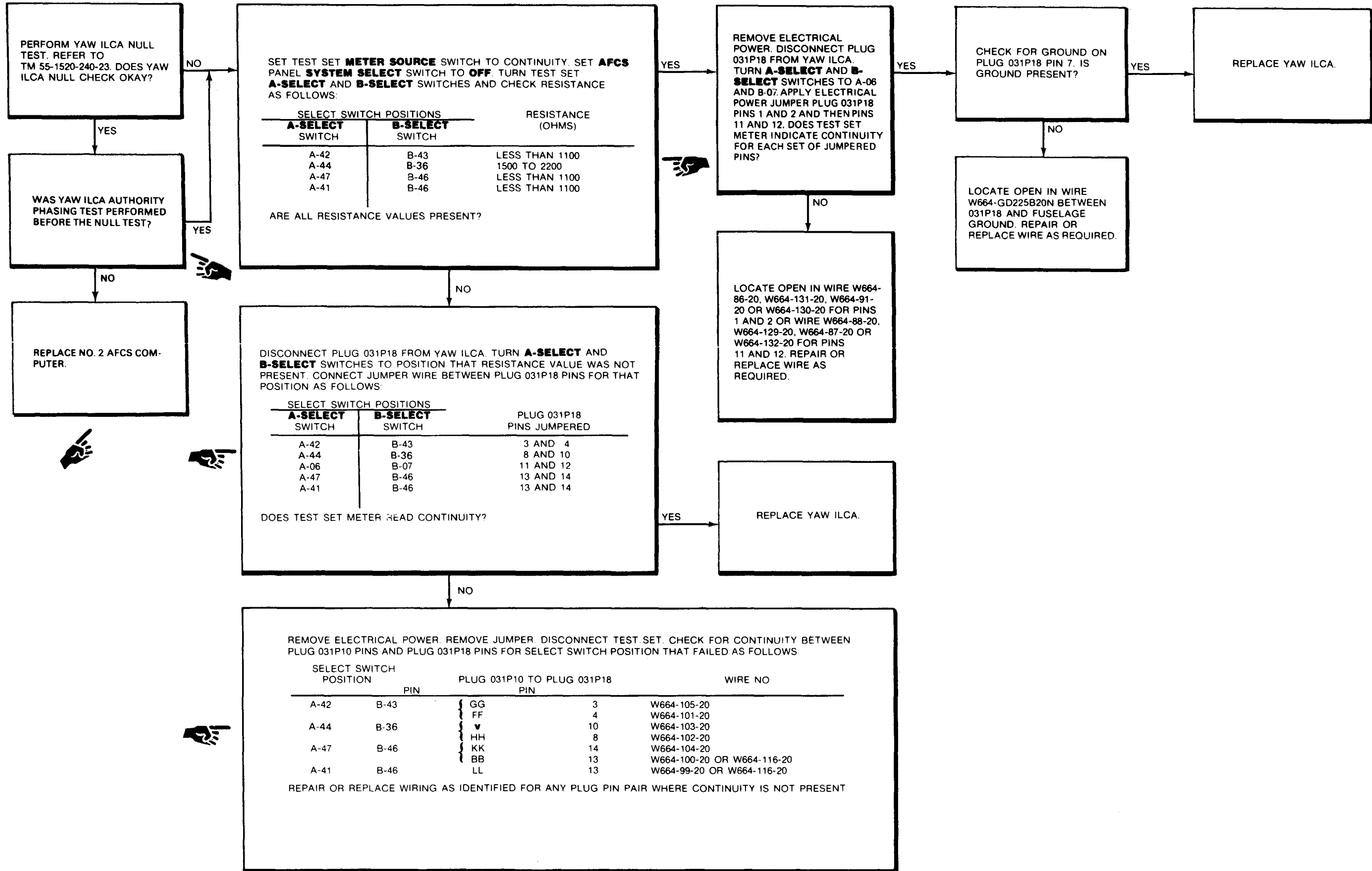

END OF TASK

11-3.31 NO. 2 YAW ILCA DOES NOT EXTEND OR RETRACT WHEN PEDALS ARE MOVED

FAULT ISOLATION PROCEDURE

INITIAL SETUP

Applicable Configurations:

All

Tools:

Electrical Repairer's Tool Kit,
NSN 5180-00-323-4915
Multimeter

Materials:

None

Personnel Required:

35K10 Avionic Mechanic
35K20 Avionic Mechanic

References:

TM 55-1520-240-23
TM 55-4920-429-13

Equipment Condition:

TM 55-1520-240-23
Battery Connected
Electrical Power On
Hydraulic Power On
TM 55-4920-429-13
AFCS Line Test Set 145G0009-1
Prepared For Use

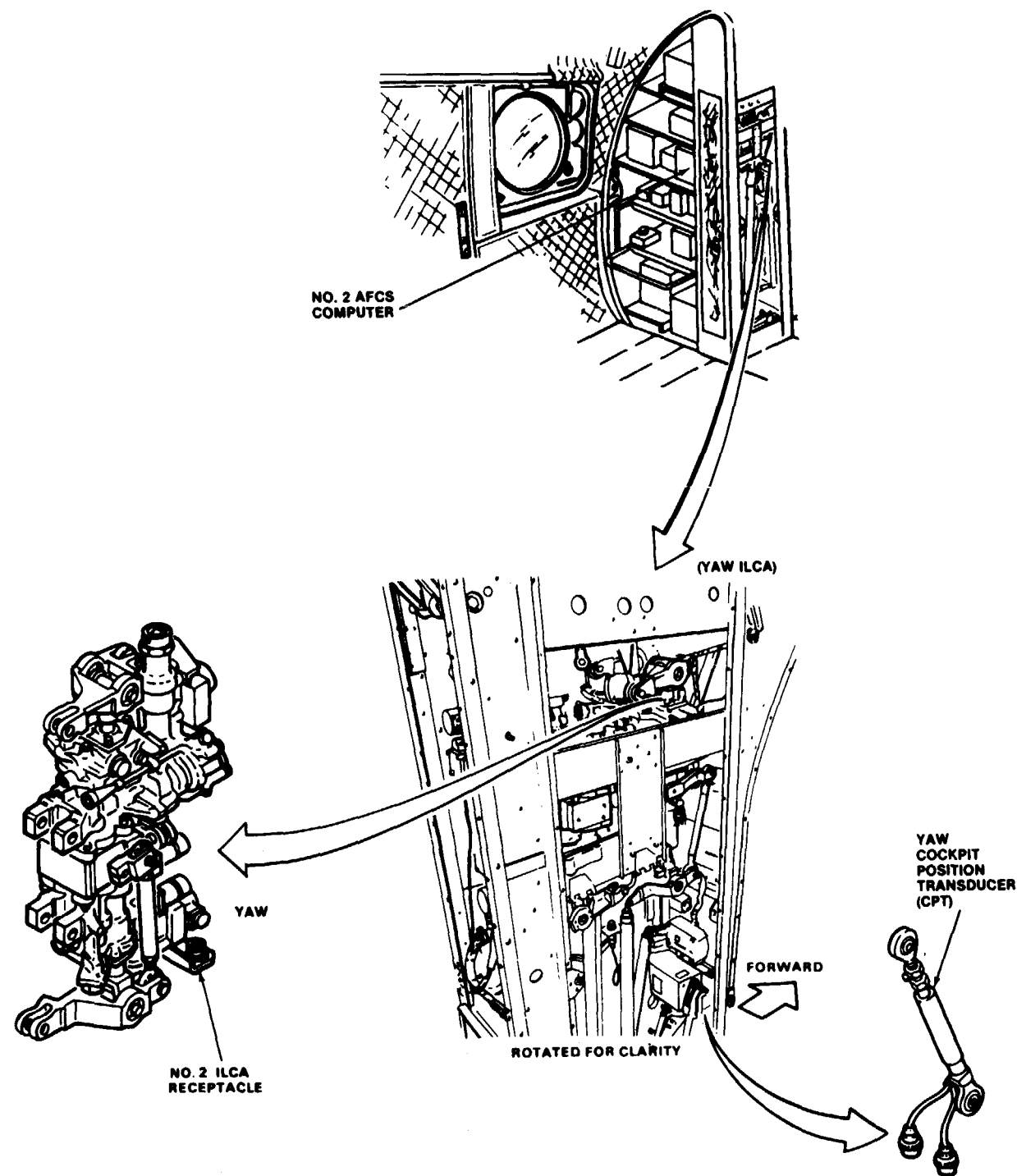
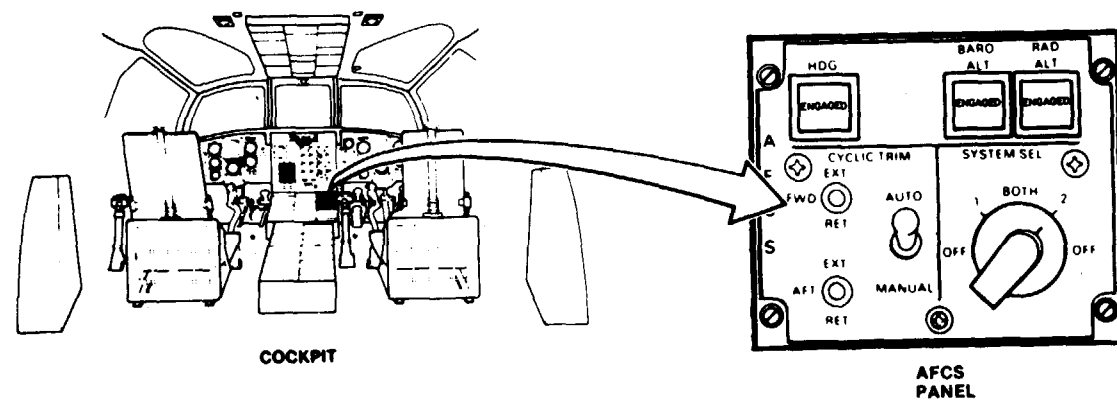

D145-11950-SPA

11-3.31 NO. 2 YAW ILCA DOES NOT EXTEND OR RETRACT WHEN PEDALS ARE MOVED (Continued)

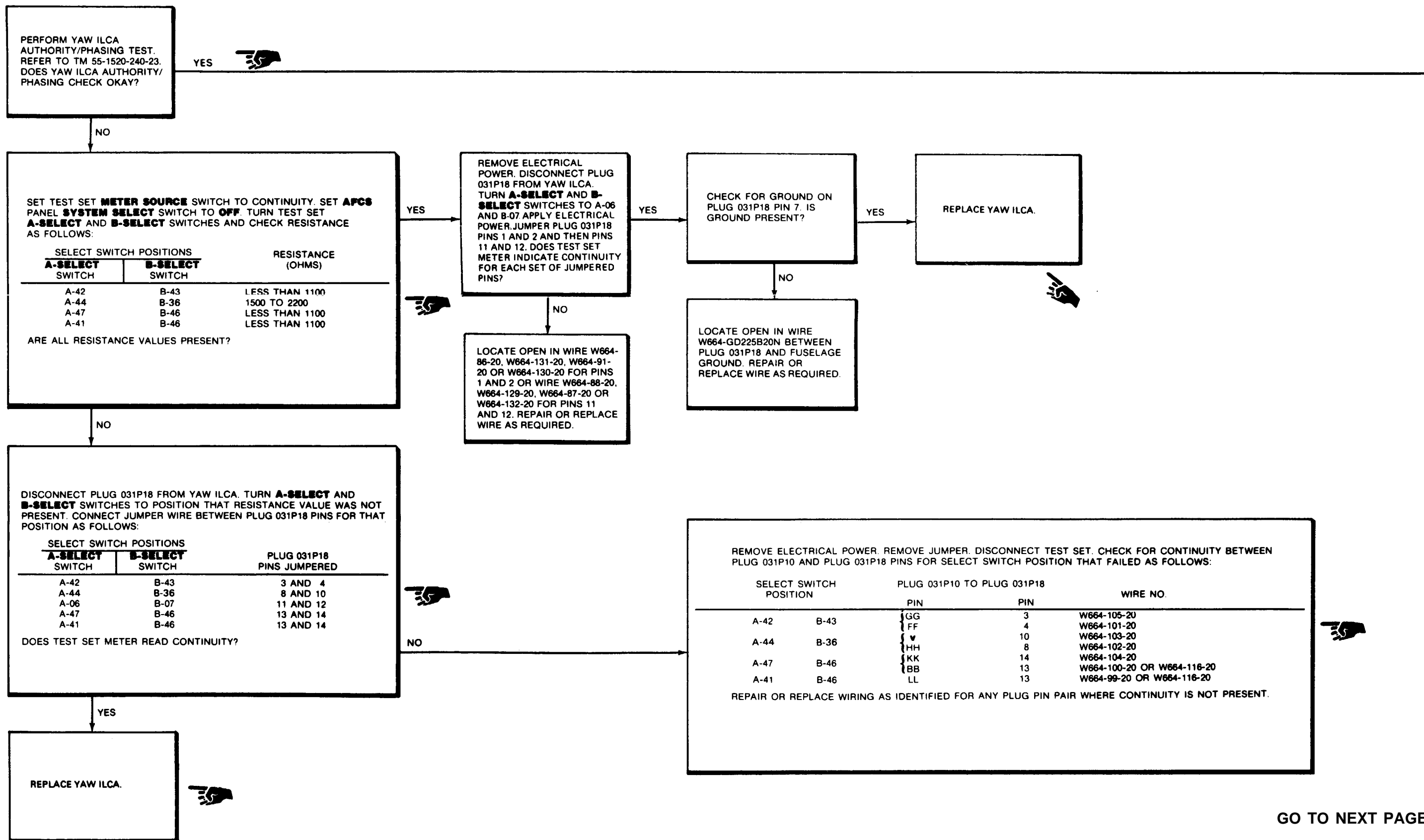

GO TO NEXT PAGE

11-3.31 NO. 2 YAW ILCA DOES NOT EXTEND OR RETRACT WHEN PEDALS ARE MOVED (Continued)

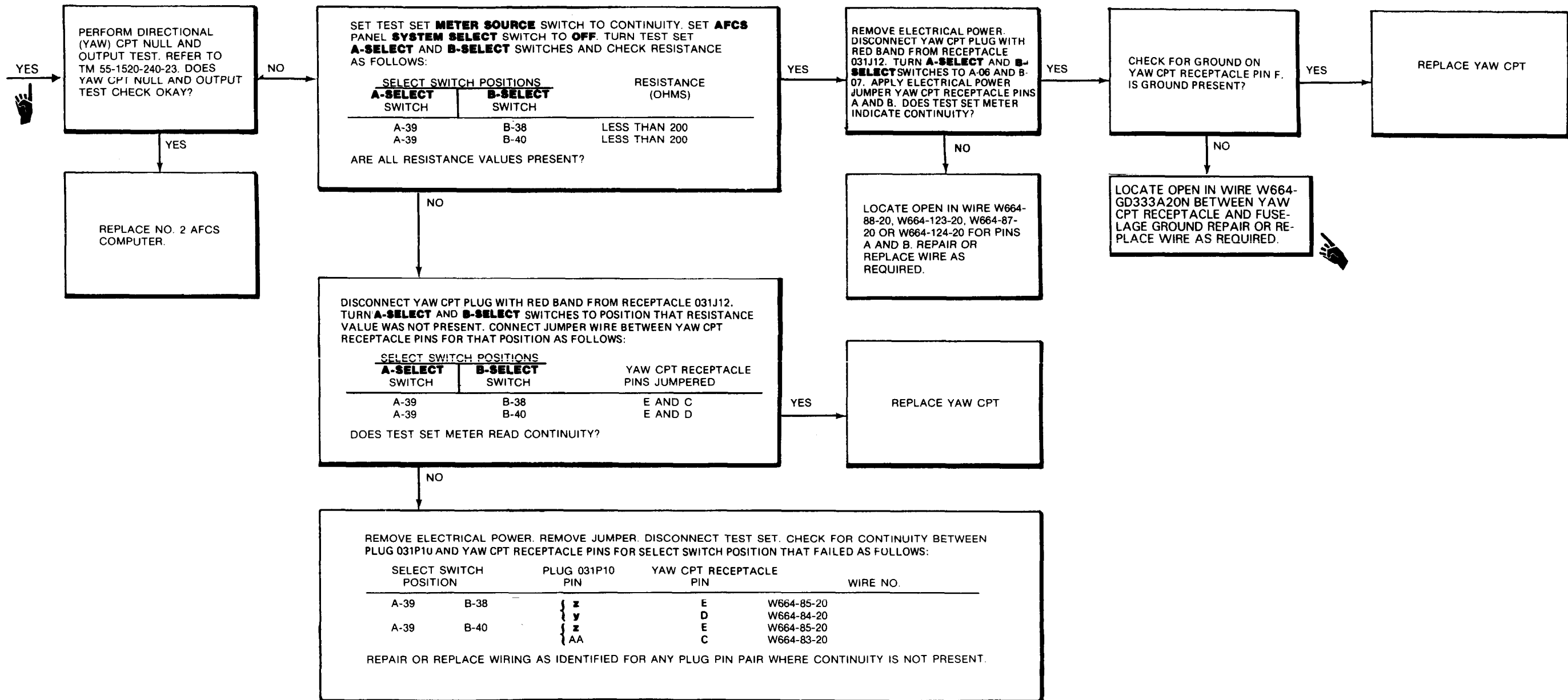

11-3.31 NO. 2 YAW ILCA DOES NOT EXTEND OR RETRACT WHEN PEDALS ARE MOVED (Continued)

11-3.31

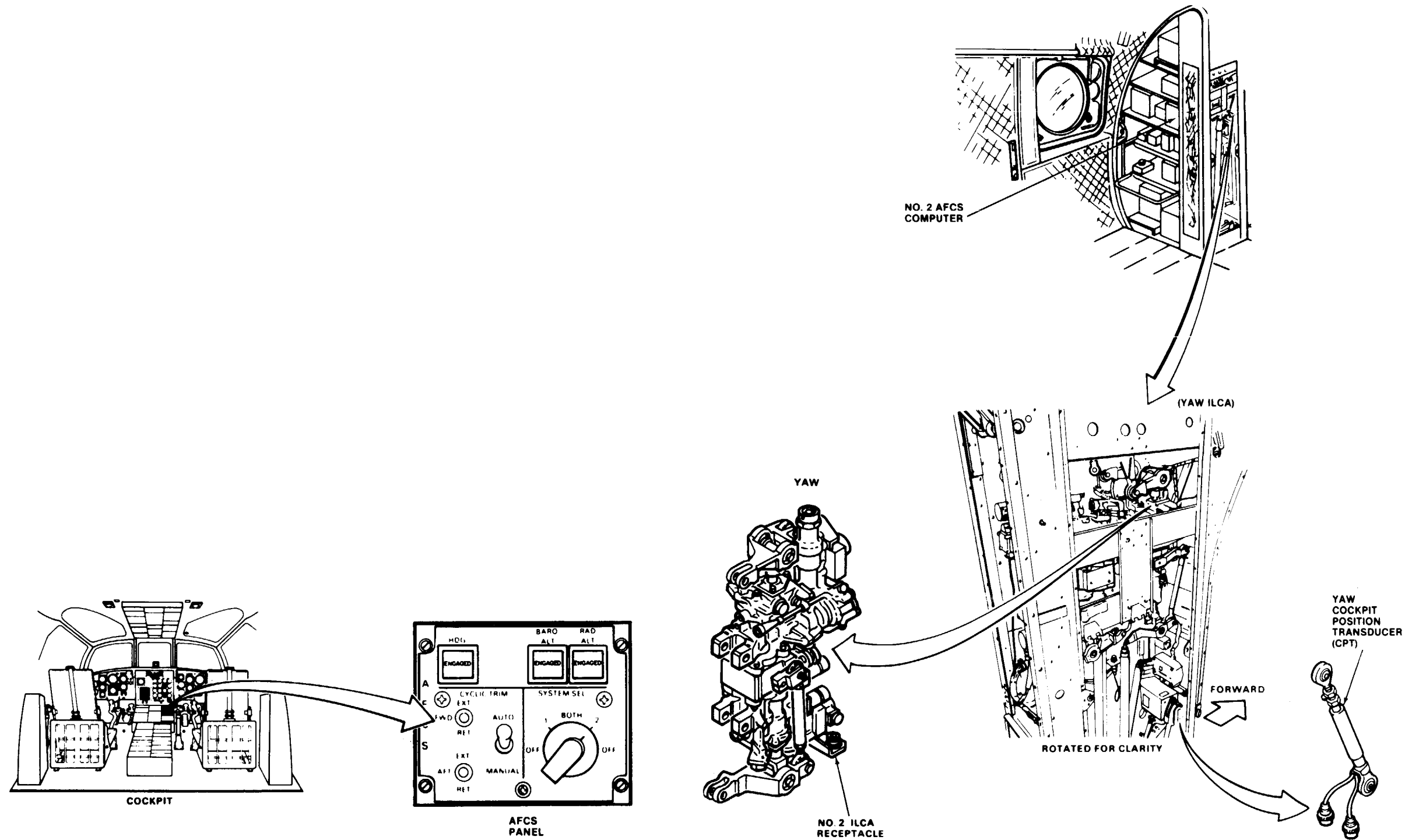

D145-12155-SPA

END OF TASK

11-125

11-3.32 NO. 2 ROLL ILCA DOES NOT EXTEND OR RETRACT WITH LATERAL STICK MOTION

FAULT ISOLATION PROCEDURE

INITIAL SETUP

Applicable Configurations:

All

Tools:

Electrical Repairer's Tool Kit,
NSN 5180-00-323-4915
Multimeter

Materials:

None

Personnel Required:

35K10 Avionic Mechanic
35K20 Avionic Mechanic

References:

TM 55-1520-240-23
TM 55-4920-429-13

Equipment Condition:

TM 55-1520-240-23
Battery Connected
Electrical Power On
Hydraulic Power On
TM 55-4920-429-13
AFCS Line Test Set 145G0009-1
Prepared For Use

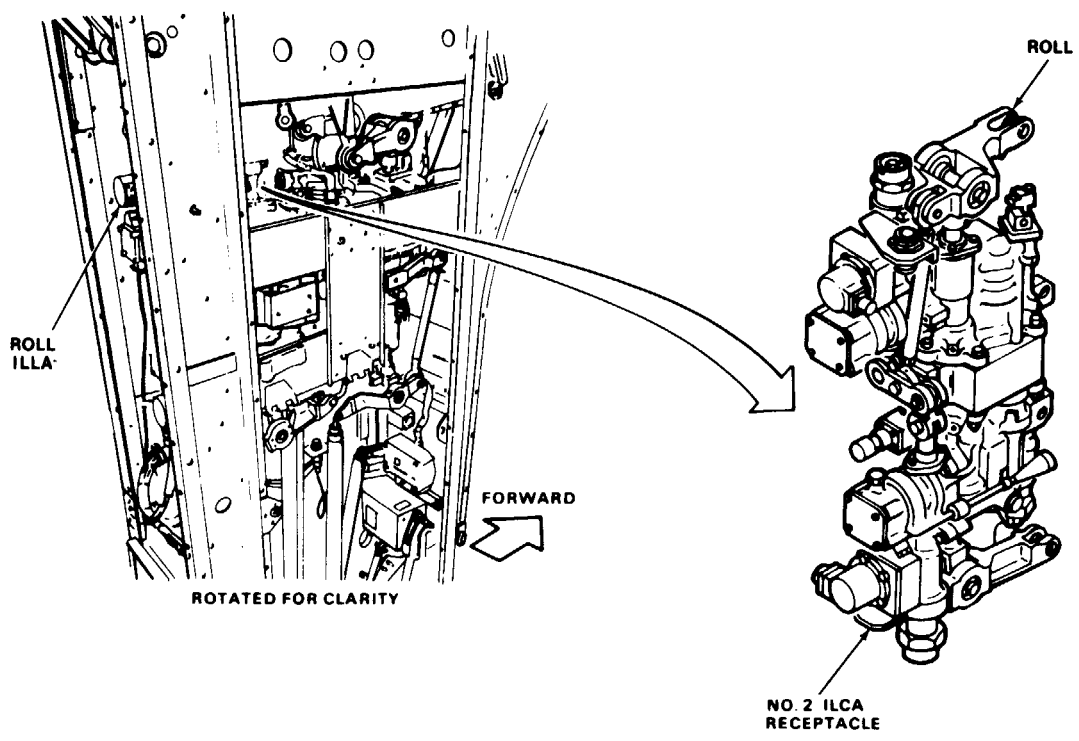
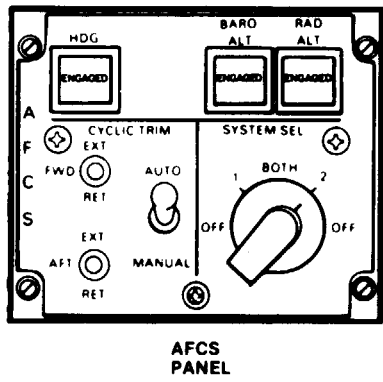
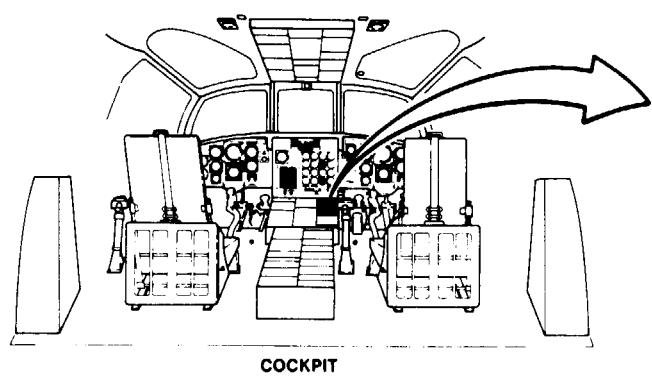
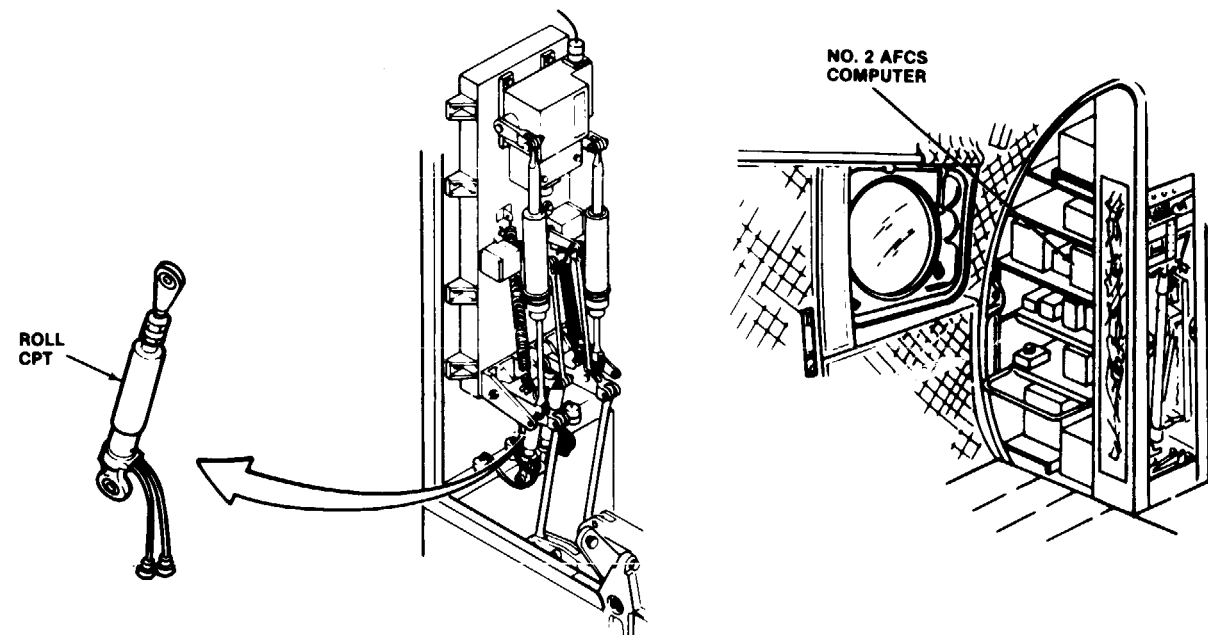

11-3.32 NO. 2 ROLL ILCA DOES NOT EXTEND OR RETRACT WITH LATERAL STICK MOTION (Continued)

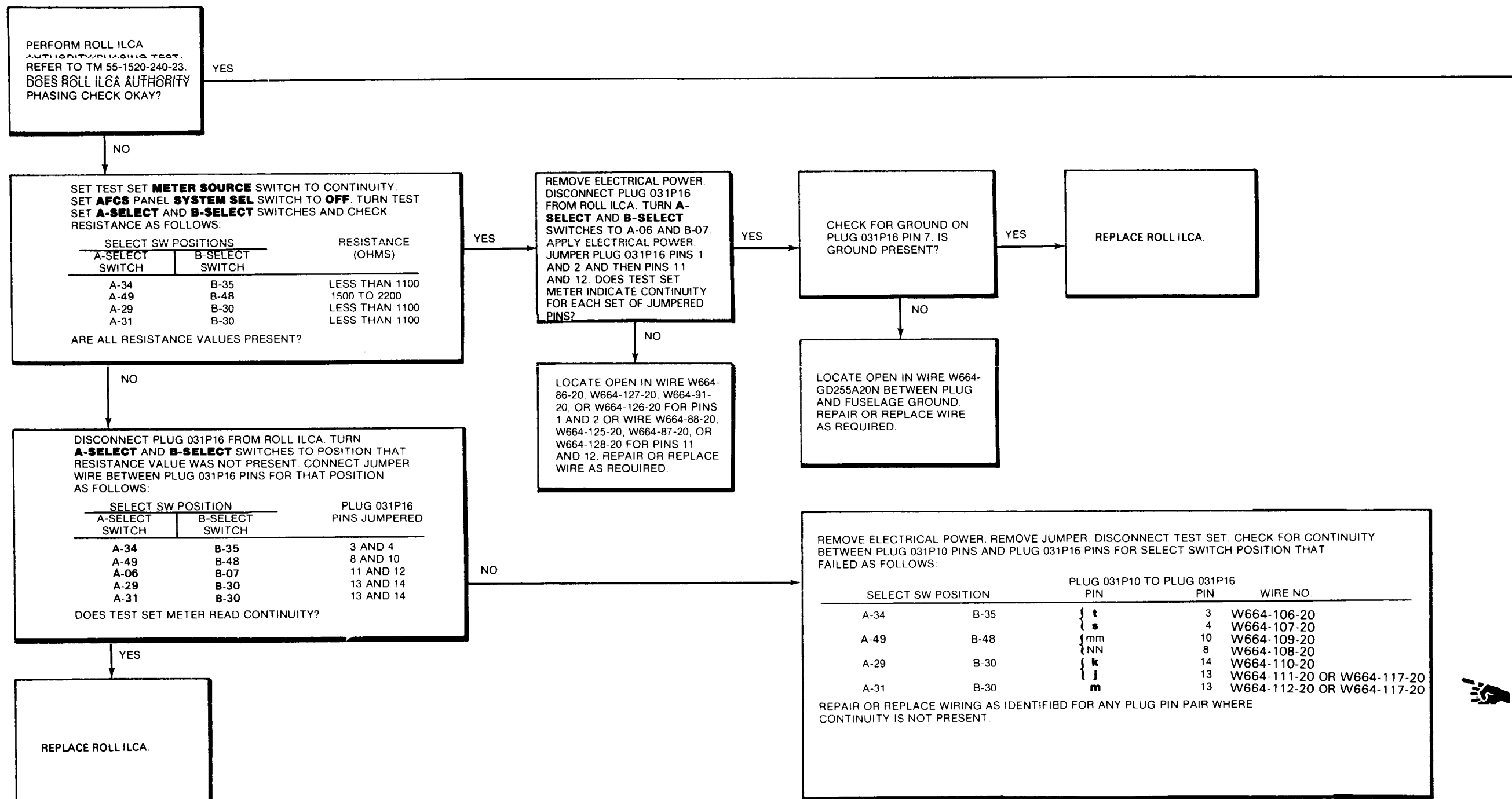

11-3.32 NO. 2 ROLL ILCA DOES NOT EXTEND OR RETRACT WITH LATERAL STICK MOTION (Continued)

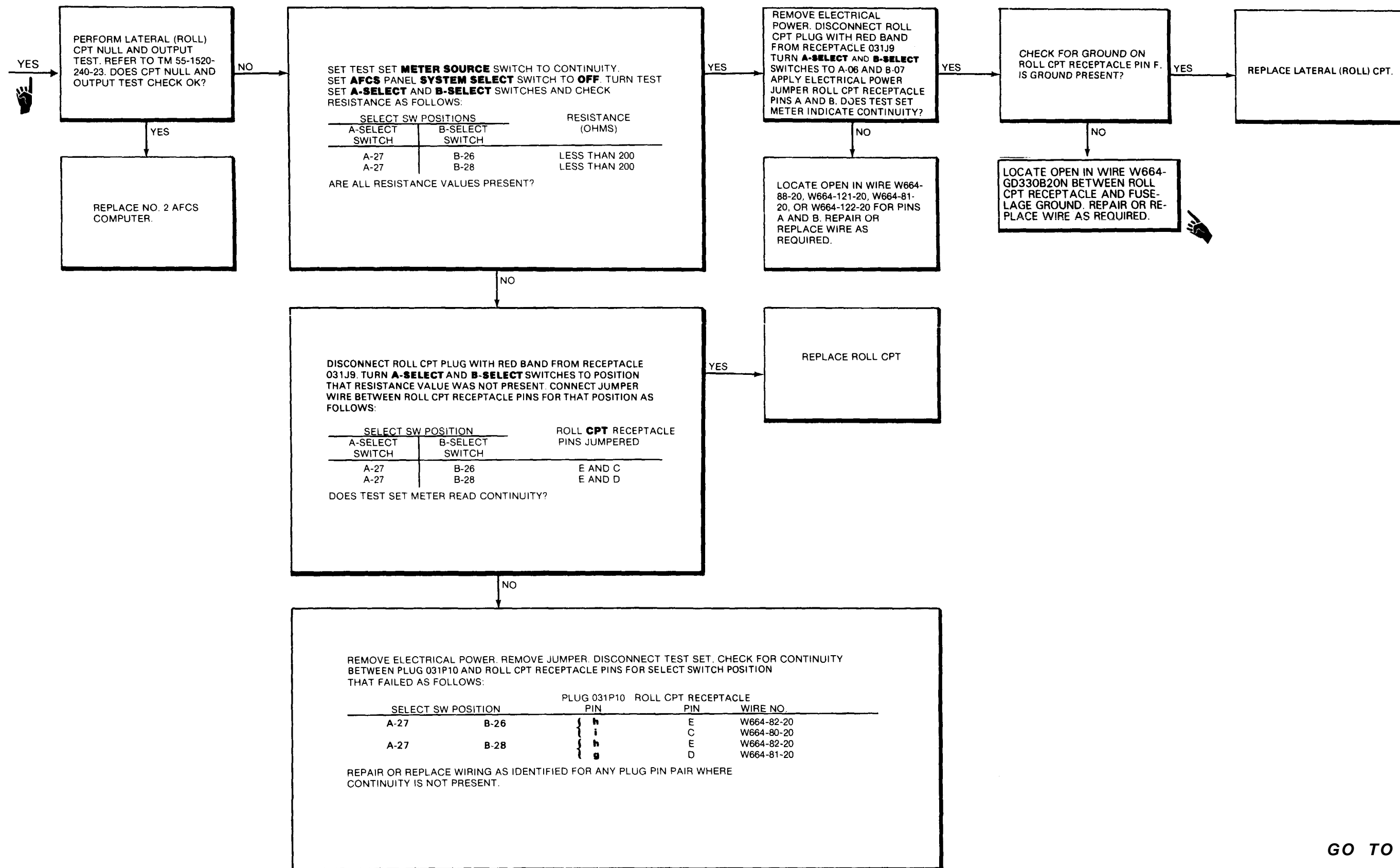

11-3.32 NO. 2 ROLL ILCA DOES NOT EXTEND OR RETRACT WITH LATERAL STICK MOTION (Continued)

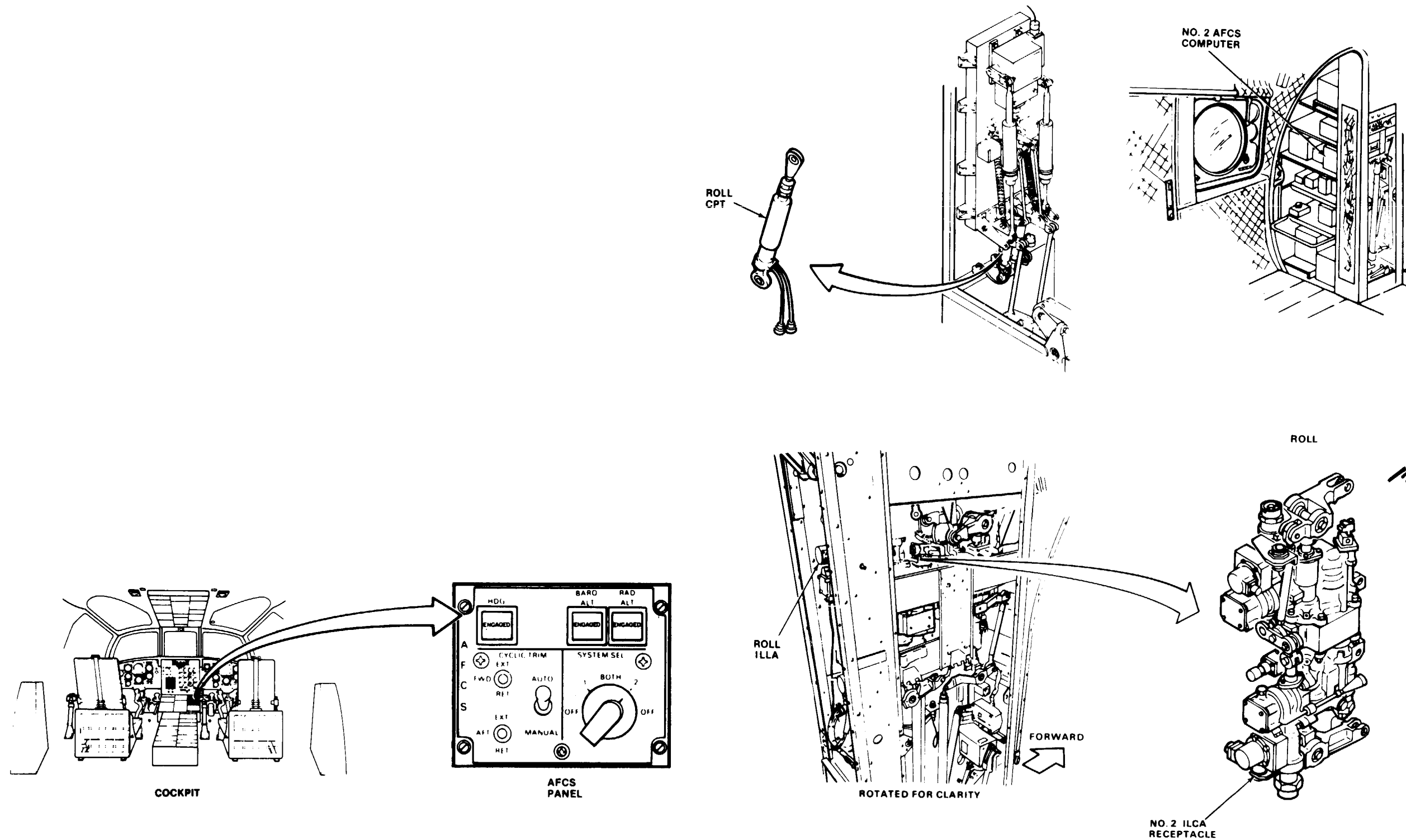

11-3.33 NO. 2 ROLL ILCA DOES NOT MOVE WHEN PILOT'S OR COPILOT'S PITCH AND ROLL TRIM SWITCH MOVED RIGHT OR LEFT

FAULT ISOLATION PROCEDURE

INITIAL SETUP

Applicable Configurations:

All

Personnel Required:

Avionic Mechanic (2)

Tools:

Electrical Repairer's Tool Kit,
NSN 5180-00-323-4915
Multimeter

References:

TM 55-1520-240-23

Equipment Condition:

TM 55-1520-240-23
Battery Connected
Electrical Power On
Hydraulic Power Off

Materials:

None

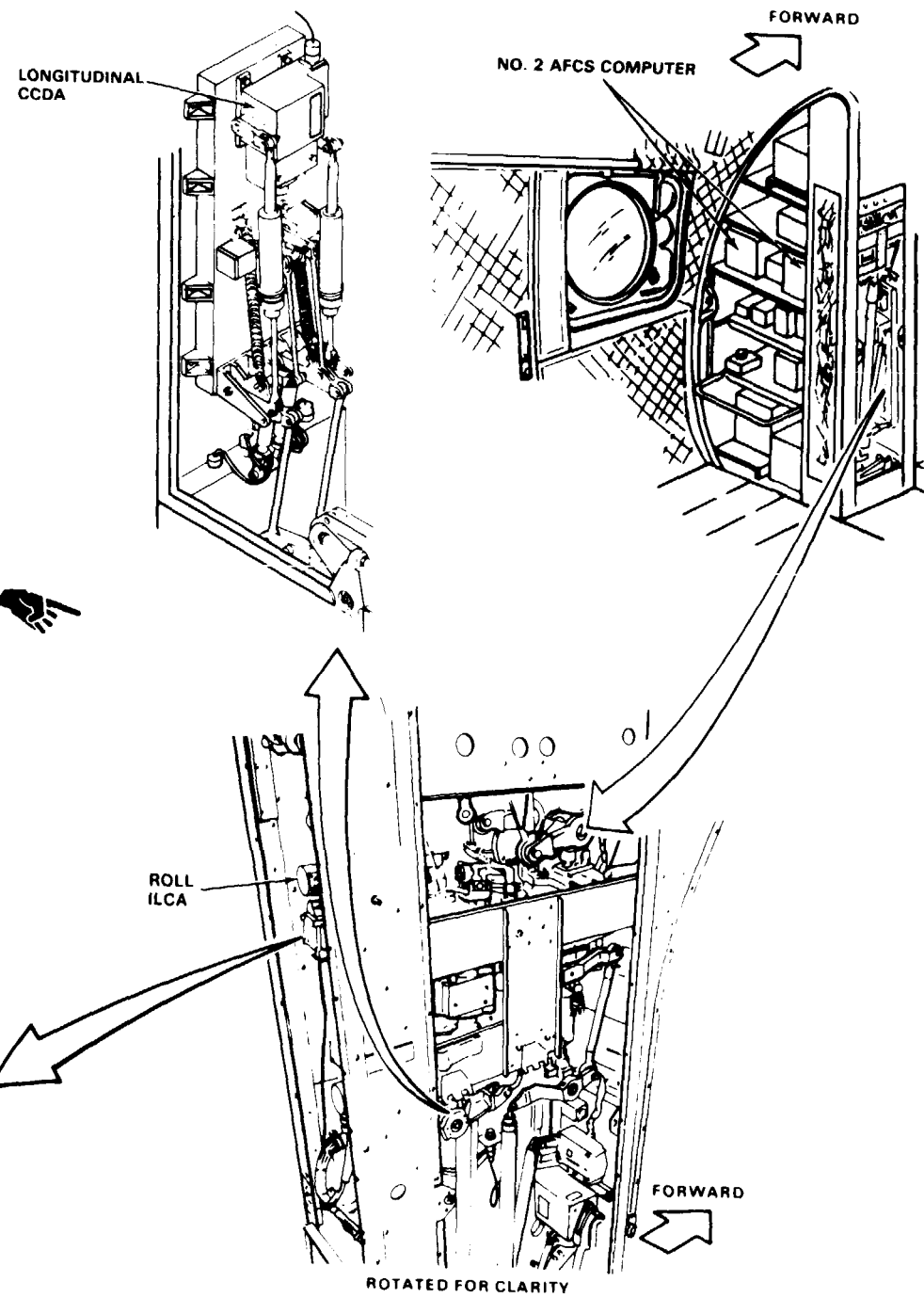
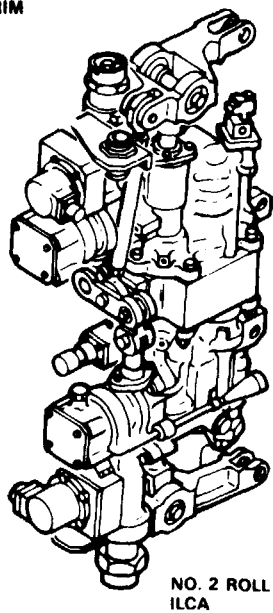
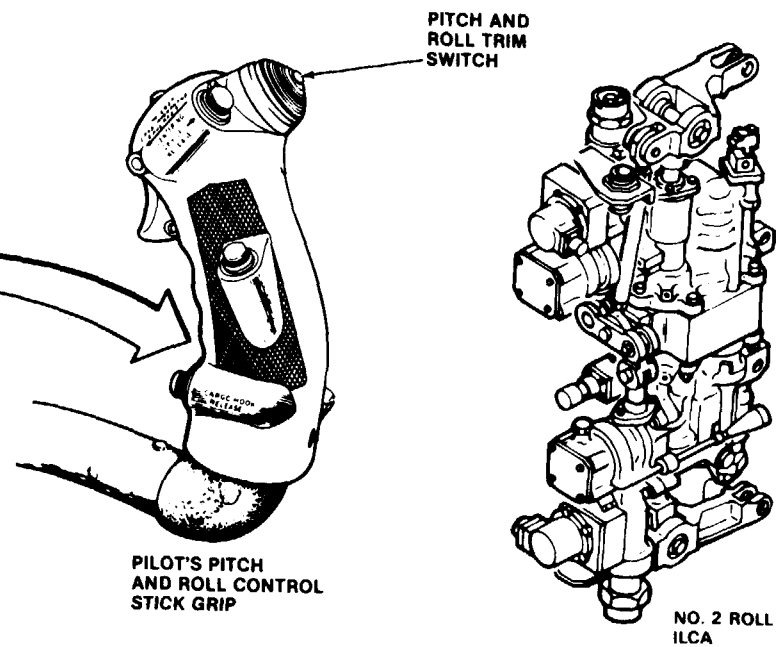
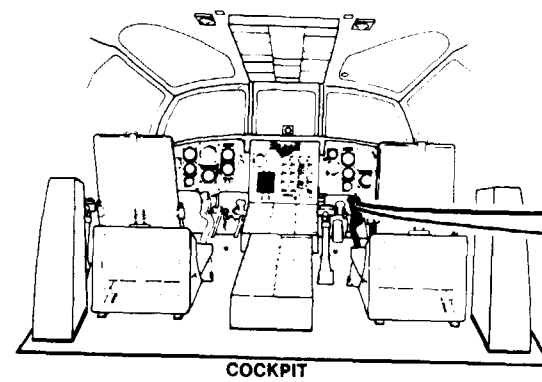

11-3.33 NO. 2 ROLL ILCA DOES NOT MOVE WHEN PILOT'S OR COPILOT'S PITCH AND ROLL TRIM SWITCH MOVED RIGHT OR LEFT (Continued)

11-3.33

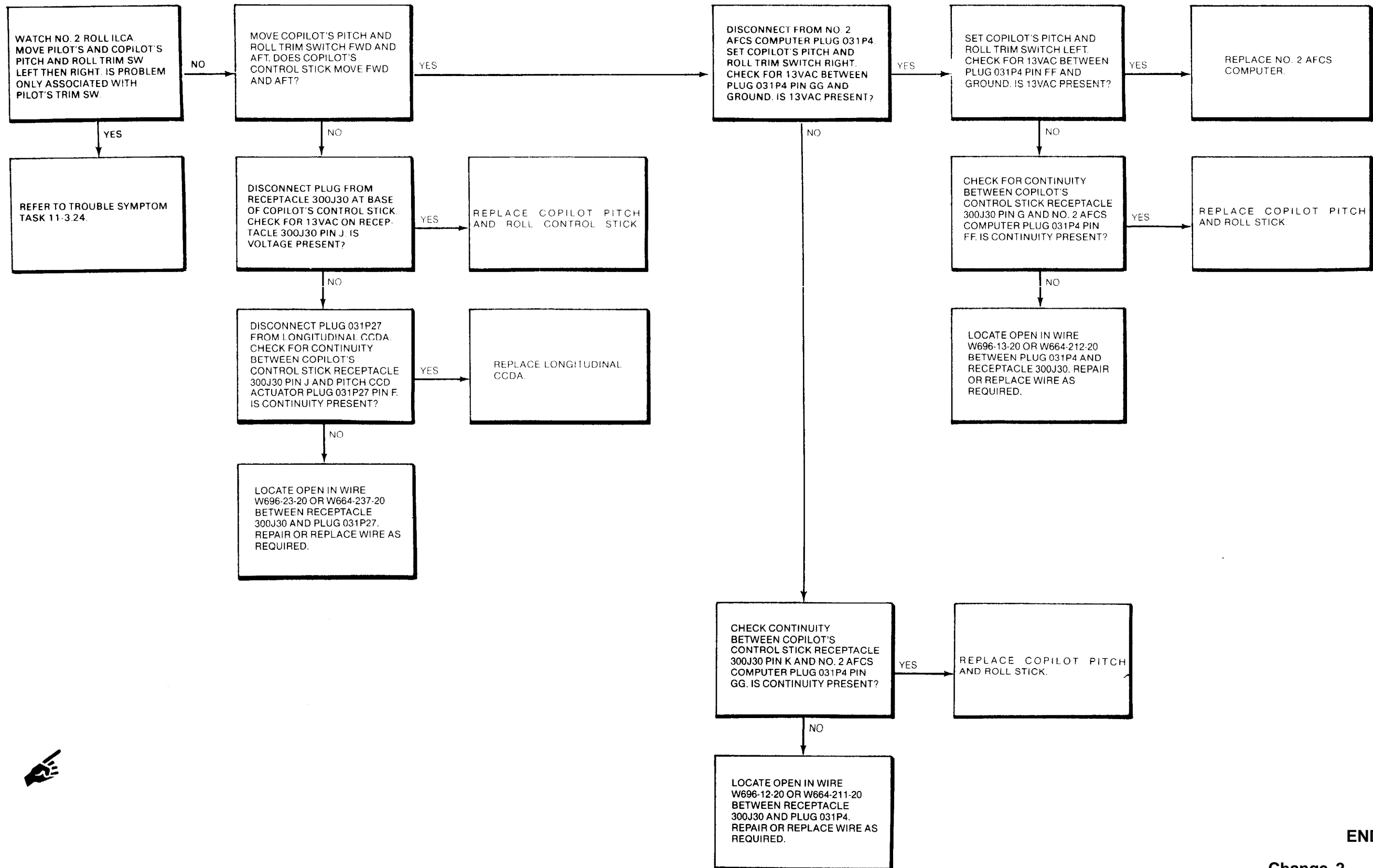

END OF TASK

FAULT ISOLATION PROCEDURE

INITIAL SETUP

Applicable Configurations:

All

Tools:

Electrical Repairer's Tool Kit,
NSN 5180-00-323-4915
Multimeter

Materials:

None

Personnel Required:

Avionic Mechanic (2)

References:

TM 55-1520-240-23

Equipment Condition:

TM 55-1520-240-23:
Battery Connected
Electrical Power On
Hydraulic Power On

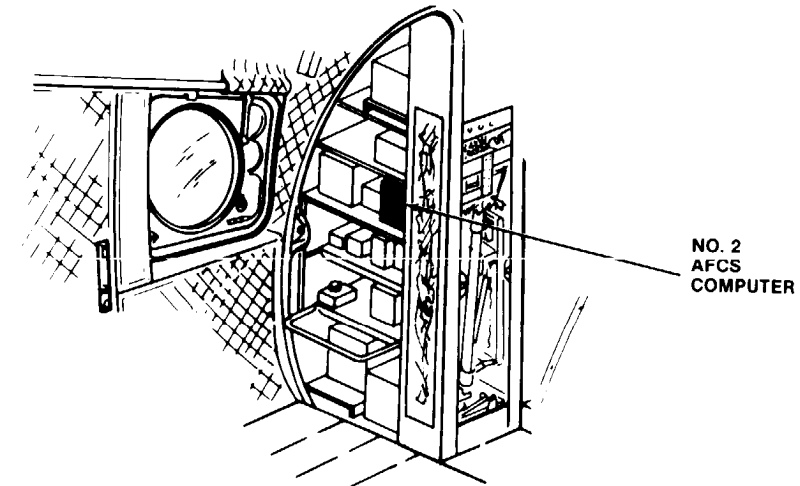
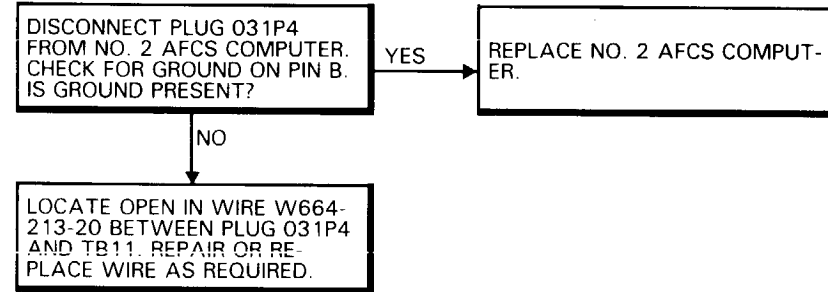

D145-11935-SPA

11-3.34.1 FORWARD LCT ACTUATOR OPERATIONAL CHECK

11-3.34.1

INITIAL SETUP

Applicable Configurations:

All

Tools:

Digital Ohmmeter

Materials:

None

Personnel Required:

Aircraft Electrician

Medium Helicopter Repairer

References:

TM 55-1520-240-23

Equipment Condition:

TM 55-1520-240-23:

Battery Connected

Electrical Power On

Hydraulic Power On

Work Platform Open

TASK	RESULT
1. Set cyclic trim switch (1) to MANUAL position.	
<div style="border: 1px dashed black; padding: 2px; display: inline-block;">CAUTION</div> Do not operate the LCT actuators without hydraulic power on the helicopter.	
2. Using FWD (EXT-RET) switch (2), fully retract the FWD LCT actuator (3).	
3. Remove electrical power from the actuator and disconnect the connector.	
4. Using a digital ohmmeter, check pins A and C of FWD actuator connection (Task 11-3.1).	Circuit should show open.
5. Reconnect the actuator and apply electrical power.	
6. Using FWD (EXT-RET) switch (2), fully extend the FWD LCT actuator (3).	
7. Remove electrical power from the actuator and disconnect the connector.	
8. Using a digital ohmmeter, check pins B and C of FWD actuator connection (Task 11-3.1).	Circuit should show open.

TASK	RESULT
9. Reconnect the actuator and apply electrical power.	
10. Using FWD (EXT-RET) switch (2), operate the FWD actuator from full extend to full retract. Clock the travel time.	Time must not exceed 25 seconds.
11. Using FWD (EXT-RET) switch (2), operate the FWD actuator from full retract to full extend. Clock the travel time.	Time must not exceed 25 seconds
12. Manually operate the actuator to full retract.	If acceptable FWD actuator operation is not obtained in all preceding steps, replace defective actuator (TM 55-1520-240-23).
13. Move cyclic trim switch (1) to AUTO.	Cockpit LCT indicator (4) should show GND.
14. Perform an AFCS BITE TEST on the No. 1 and No. 2 systems (Task 11-3.3).	Failure of any AFCS BITE steps for LCT operation indicates possible actuator defects, Replace defective actuator (TM 55-1520-240-23),
15. Monitor the cockpit LCT indicator (4).	Erratic indicator movement indicates possible actuator defect. Replace defective actuator (TM 55-1520-240-23).

FOLLOW-ON MAINTENANCE:

TM 55-1520-240-23:

Hydraulic power off.

Electrical power off.

Battery disconnected.

Work platform closed.

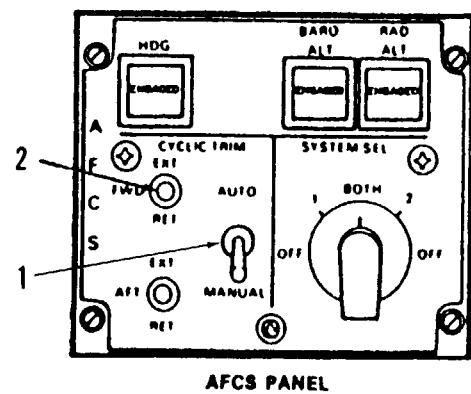
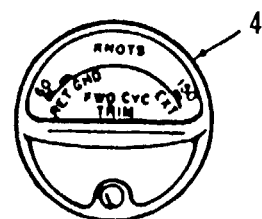
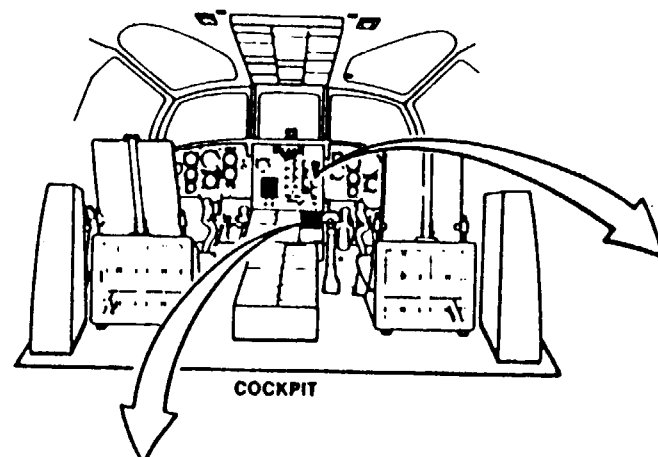
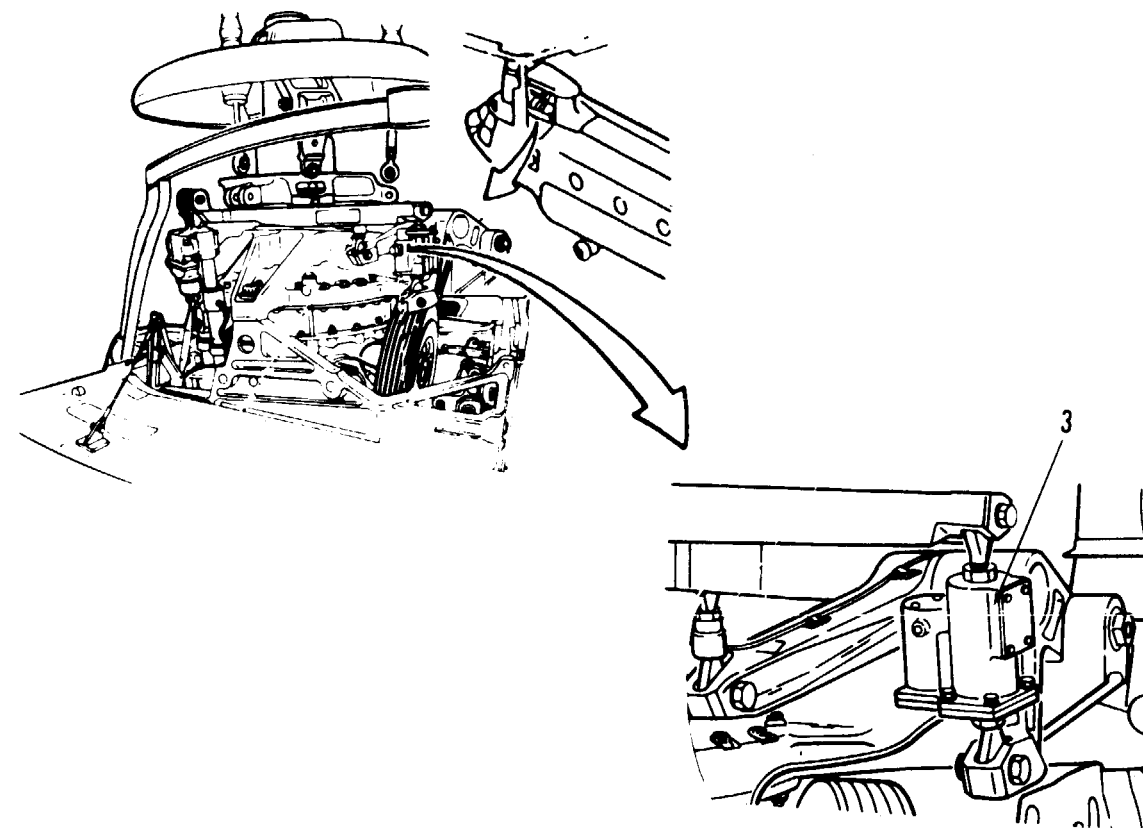

11-3.34.2 AFT LCT ACTUATOR OPERATIONAL CHECK

INITIAL SETUP

Applicable Configurations:

All

Tools:

Digital Ohmmeter

Materials:

None

Personnel Required:

Aircraft Electrician

Medium Helicopter Repairer

References:

TM 55-1520-240-23

Equipment Condition:

TM 55-1520-240-23:

Battery Connected

Electrical Power On

Hydraulic Power On

Work Platform Open

TASK	RESULT
1. Set cyclic trim switch (1) to MANUAL position.	
<div style="border: 1px dashed black; padding: 2px; display: inline-block;">CAUTION</div> Do not operate the LCT actuators without hydraulic power on the helicopter.	
2. Using AFT (EXT-RET) switch (2), fully retract the AFT LCT actuator (3).	
3. Remove electrical power from the actuator and disconnect the connector.	
4. Using a digital ohmmeter, check pins A and C of AFT actuator connection (Task 11-3.1).	Circuit should show open.
5. Reconnect the actuator and apply electrical power.	
6. Using AFT (EXT-RET) switch (2), fully extend the AFT LCT actuator (3).	
7. Remove electrical power from the actuator and disconnect the connector.	
8. Using a digital ohmmeter, check pins B and C of AFT actuator connection (Task 11-3.1).	Circuit should show open.

TASK	RESULT
9. Reconnect the actuator and apply electrical power.	
10. Using AFT (EXT-RET) switch (2), operate the AFT actuator (3) from full extend to full retract. Clock the travel time.	Time must not exceed 25 seconds.
11. Using AFT (EXT-RET) switch (2), operate the AFT actuator (3) from full retract to full extend. Clock the travel time.	Time must not exceed 25 seconds.
12. Manually operate the actuator to full retract.	If acceptable AFT actuator operation is not obtained in all preceding steps, replace defective actuator (TM 55-1520-240-23).
13. Move cyclic trim switch (1) to AUTO.	Cockpit LCT indicator (4) should show GND.
14. Perform an AFCS BITE TEST on the No. 1 and No. 2 systems (Task 11-3.3).	Failure of any AFCS BITE steps for LCT operation indicates possible actuator defect. Replace defective actuator (TM 55-1520-240-23).
15. Monitor the cockpit LCT indicator (4).	Erratic indicator movement indicates possible actuator defect. Replace defective actuator (TM 55-1520-240-23).

FOLLOW-ON MAINTENANCE:

TM 55-1520-240-23:

Hydraulic power off.

Electrical power off.

Battery disconnected.

Work platform closed.

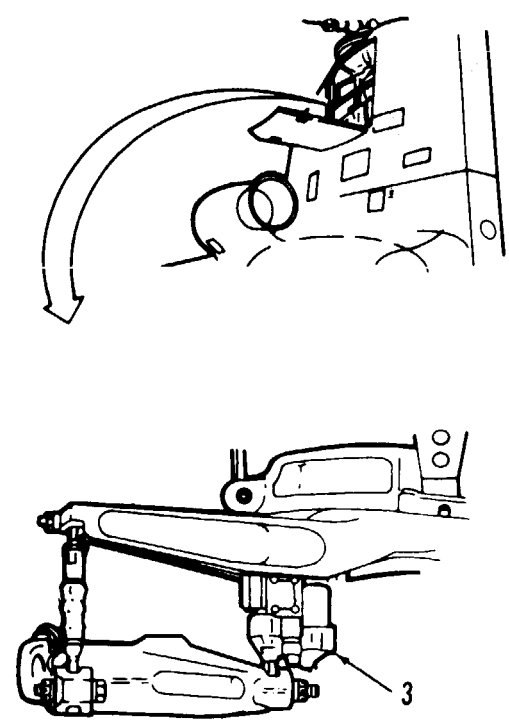
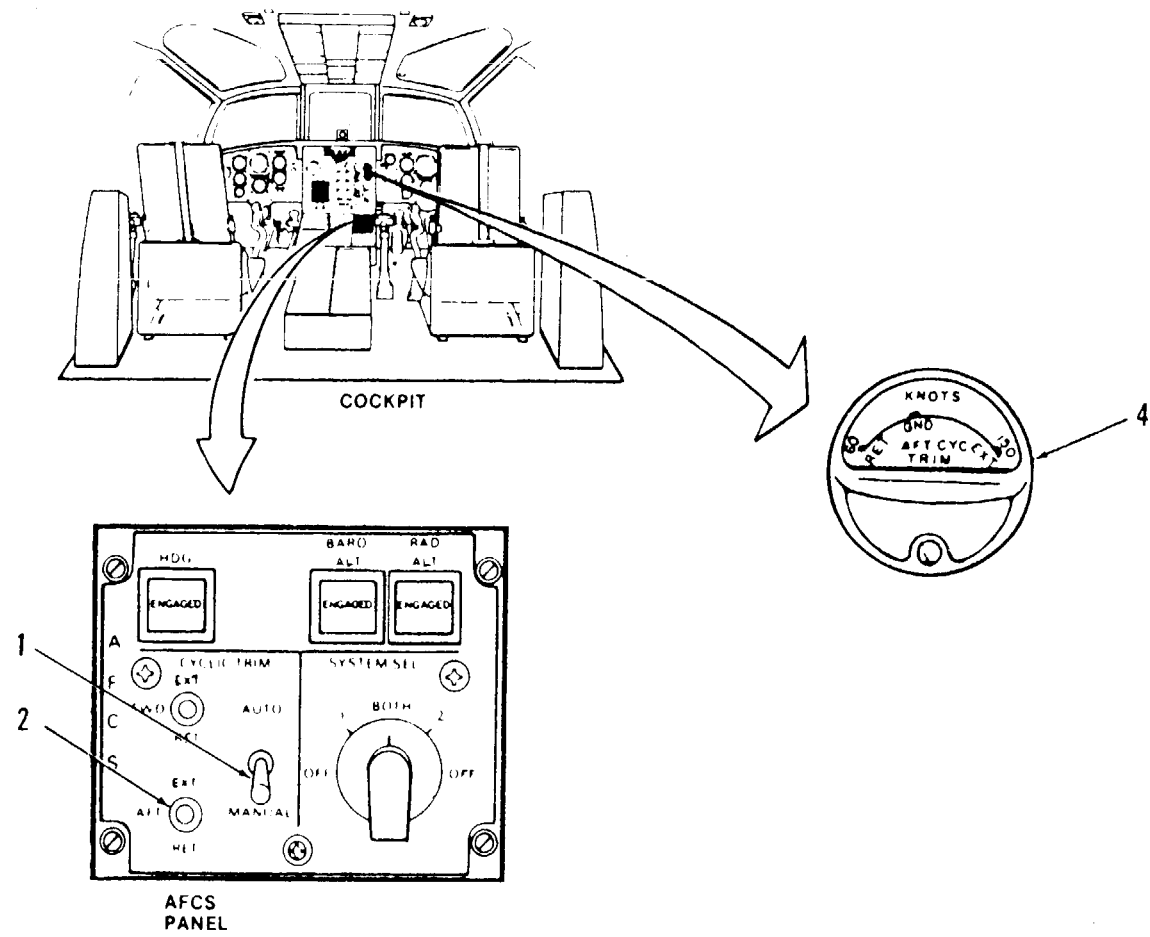

INITIAL SETUP

Applicable Configurations:

All

Tools:

None

Materials:

None

Personnel Required:

Aircraft Electrician

Medium Helicopter Repairer

References:

TM 55-1520-240-23

Equipment Condition:

TM 55-1520-240-23

Battery Connected

Electrical Power On

Hydraulic Power On

Work Platform Open

TASK	RESULT
1. Perform forward and aft LCT actuator operational checks (Tasks 11-3.34.1 and 11-3.34.2).	
2. Inspect forward and aft LCT actuators.	Replace LCT actuators as required (TM 55-1520-240-23).
3. Inspect helicopter wires and connectors for damage and contamination (Task 11-3.1).	

11-3.34.3 LCT ACTUATOR CONTROL TRANSISTOR BURNS OUT (Continued)

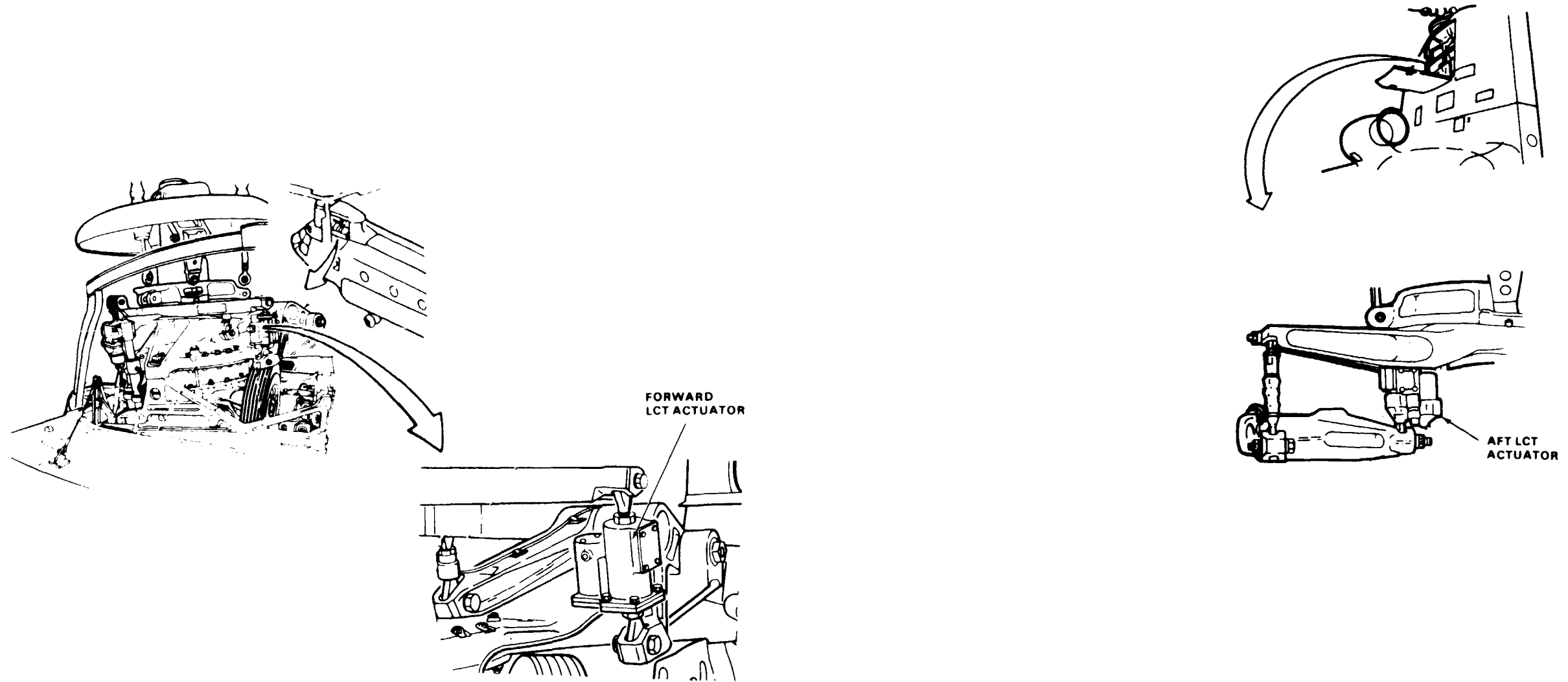

END OF TASK

FAULT ISOLATION PROCEDURE

INITIAL SETUP

Applicable Configurations:

All

Tools:

- Electrical Repairer's Tool Kit,
NSN 5180-00-323-4915
- Multimeter

Materials:

None

Personnel Required:

- Avionic Mechanic
- Avionic Mechanic

References:

TM 55-1520-240-23

Equipment Condition:

- TM 55-1520-240-23:
- Battery Connected
- Electrical Power On
- Hydraulic Power On

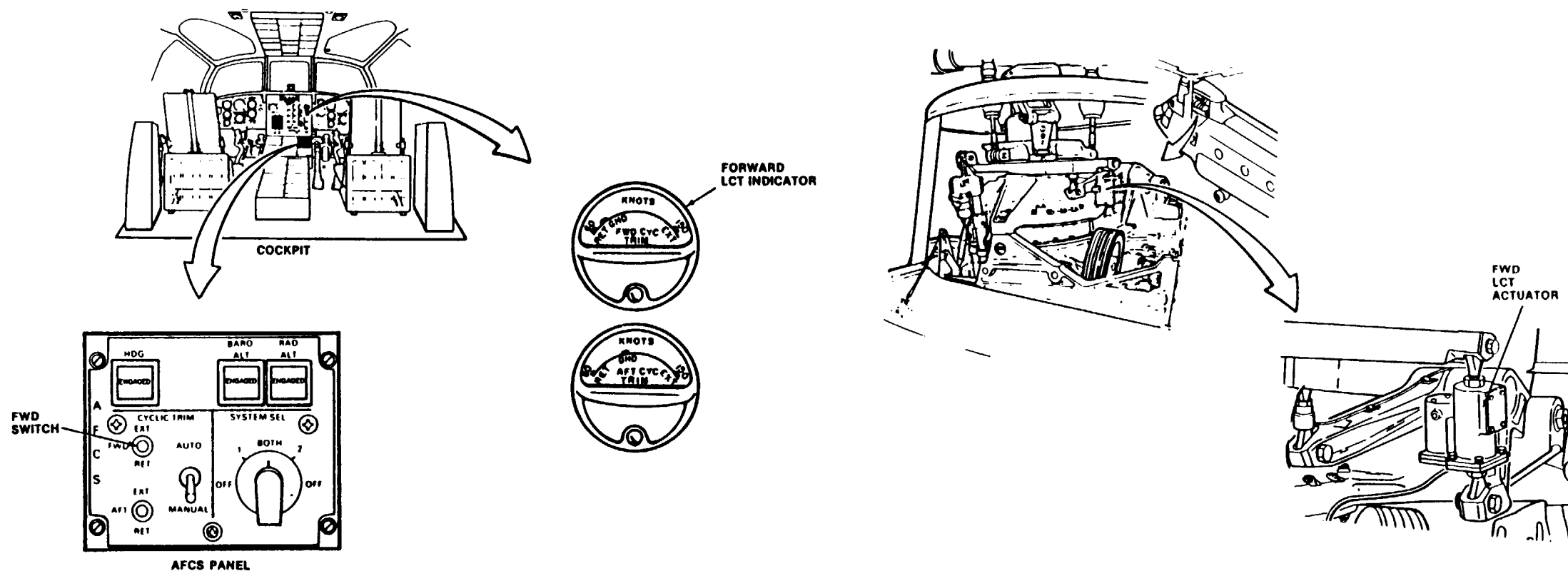
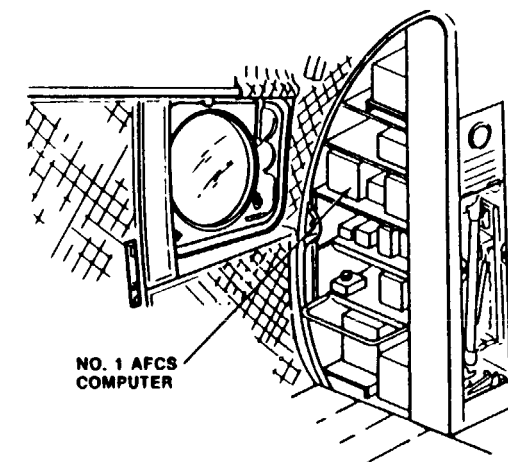

DI45-11919-SPA

This page intentionally left blank

11-3.34.1 FORWARD LCT ACTUATOR OPERATIONAL CHECK

INITIAL SETUP

Applicable Configurations:

All

Tools:

Digital Ohmmeter

Materials:

None

Personnel Required:

Aircraft Electrician
Medium Helicopter Repairer

References:

TM 55-1520-240-23

Equipment Condition:

TM 55-1520-240-23
Battery Connected
Electrical Power On
Hydraulic Power On
Work Platform Open

TASK	RESULT
1. Set cyclic trim switch (1) to MANUAL position.	
 <p>CAUTION</p> <p>Do not operate the LCT actuators manually without hydraulic power on the helicopter.</p>	
2. Using FWD (EXT-RET) switch (2), fully retract the FWD LCT actuator (3).	
3. Remove electrical power from the actuator and disconnect the connector.	
4. Using a digital ohmmeter, check pins A and C of FWD actuator connection (TASK 11-3.1).	Circuit should show open.
5. Reconnect the actuator and apply electrical power.	
6. Using FWD (EXT-RET) switch (2), fully extend the FWD LCT actuator (3).	
7. Remove electrical power from the actuator and disconnect the connector.	
8. Using a digital ohmmeter, check pins B and C of FWD actuator connection (TASK 11-3.1).	Circuit should show open.

TASK	RESULT
9. Reconnect the actuator and apply electrical power.	
10. Using FWD (EXT-RET) switch (2), operate the FWD actuator from full extend to full retract. Clock the travel time.	Time must not exceed 25 seconds.
11. Using FWD (EXT-RET) switch (2), operate the FWD actuator from full retract to full extend. Clock the travel time.	Time must not exceed 25 seconds.
12. Manually operate the actuator to full retract.	If acceptable FWD actuator operation is not obtained in all preceding steps, replace defective actuator (TM 55-1520-240-23).
13. Move cyclic trim switch (1) to AUTO.	Cockpit LCT indicator (4) should show GND.
14. Perform an AFCS BITE TEST on the No. 1 and No. 2 systems (TASK 11-3.3).	Failure of any AFCS BITE steps for LCT operation indicates possible actuator defects. Replace defective actuator (TM 55-1520-240-23).
15. Monitor the cockpit LCT indicator (4).	Erratic indicator movement indicates possible actuator defect. Replace defective actuator (TM 55-1520-240-23).

FOLLOW-ON MAINTENANCE

TM 55-1520-240-23
Hydraulic Power Off
Electrical Power Off
Battery Disconnected
Work Platform Closed

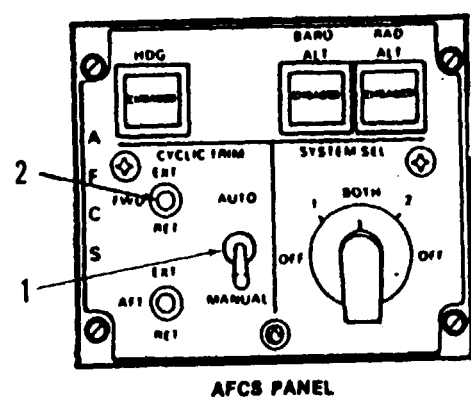
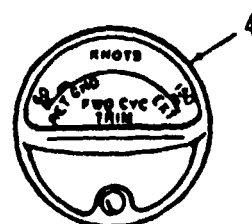
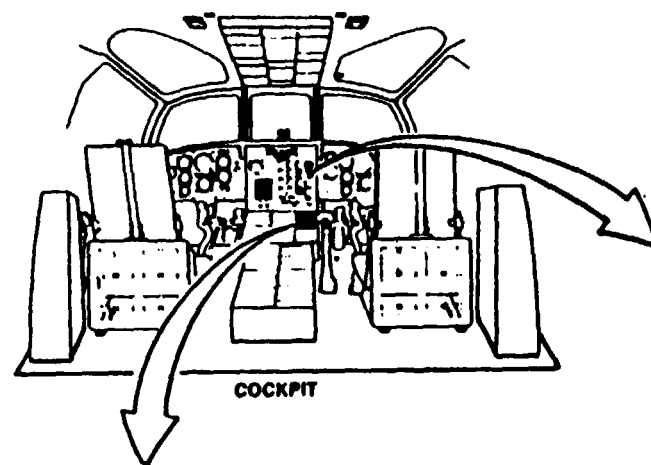
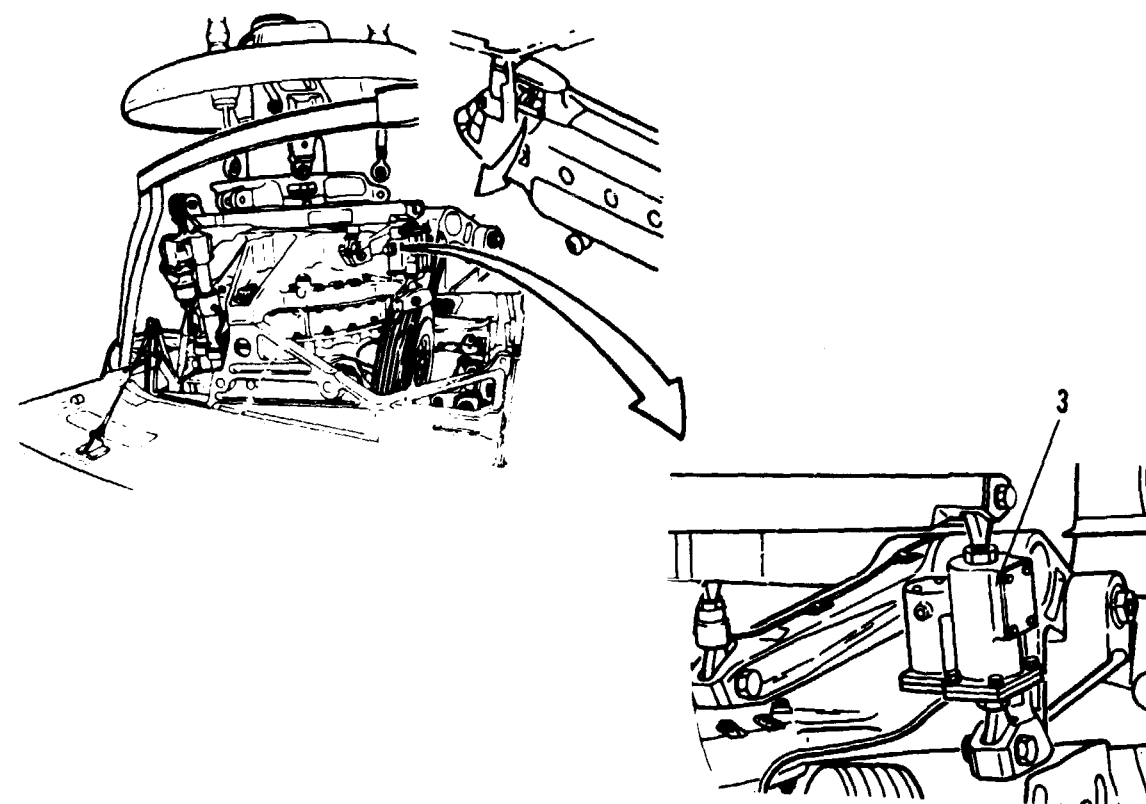

END OF TASK

Change 4 11-134.3

11-3.34.2 AFT LCT ACTUATOR OPERATIONAL CHECK

INITIAL SETUP

Applicable Configurations:
All

Tools:
Digital Ohmmeter

Materials:
None

Personnel Required:
Aircraft Electrician
Medium Helicopter Repairer

References:
TM 55-1520-240-23

Equipment Condition:
TM 55-1520-240-23
Battery Connected
Electrical Power On
Hydraulic Power On
Work Platform Open

TASK	RESULT
1. Set cyclic trim switch (1) to manual position.	
<div style="border: 1px dashed black; padding: 2px; display: inline-block;">CAUTION</div>	
Do not operate the LCT actuators manually without hydraulic power on the helicopter.	
2. Using AFT (EXT-RET) switch (2), fully retract the AFT LCT actuator.	
3. Remove electrical power from the actuator and disconnect the connector.	
4. Using a digital ohmmeter, check pins A and C of AFT actuator connection (TASK 11-3.1).	Circuit should show open.
5. Reconnect the actuator and apply electrical power.	
6. Using AFT (EXT-RET) switch (2), fully extend the AFT LCT actuator (3).	
7. Remove electrical power from the actuator and disconnect the connector.	
8. Using a digital ohmmeter, check pins B and C of AFT actuator connection (TASK 11-3.1).	Circuit should show open.

TASK	RESULT
9. Reconnect the actuator and apply electrical power.	
10. Using AFT (RET-EXT) switch (2), operate the AFT actuator (3) from full extend to full retract. Clock the travel time.	Time must not exceed 25 seconds.
11. Using AFT (RET-EXT) switch (2), operate the AFT actuator (3) from full retract to full extend. Clock the travel time.	Time must not exceed 25 seconds.
12. Manually operate the actuator to full retract.	If acceptable AFT actuator operation is not obtained in all preceding steps, replace defective actuator (TM 55-1520-240-23).
13. Move cyclic trim switch (1) to AUTO.	Cockpit LCT indicator (4) should show GND.
14. Perform an AFCS BITE TEST on the No. 1 and No. 2 systems (TASK 11-3.3).	Failure of any AFCS BITE steps for LCT operation indicates possible actuator defect. Replace defective actuator (TM 55-1520-240-23).
15. Monitor the cockpit LCT indicator (4).	Erratic indicator movement indicates possible actuator defect. Replace defective actuator (TM 55-1520-240-23).

FOLLOW-ON MAINTENANCE:

TM 55-1520-240-23
Hydraulic Power Off
Electrical Power Off
Battery Disconnected
Work Platform Closed

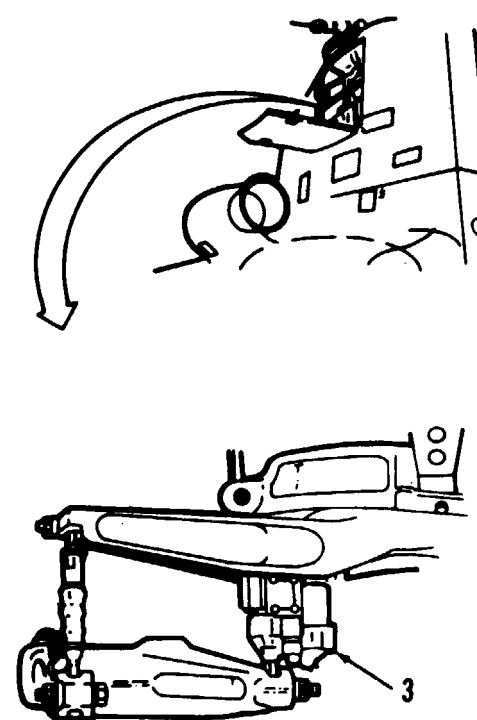
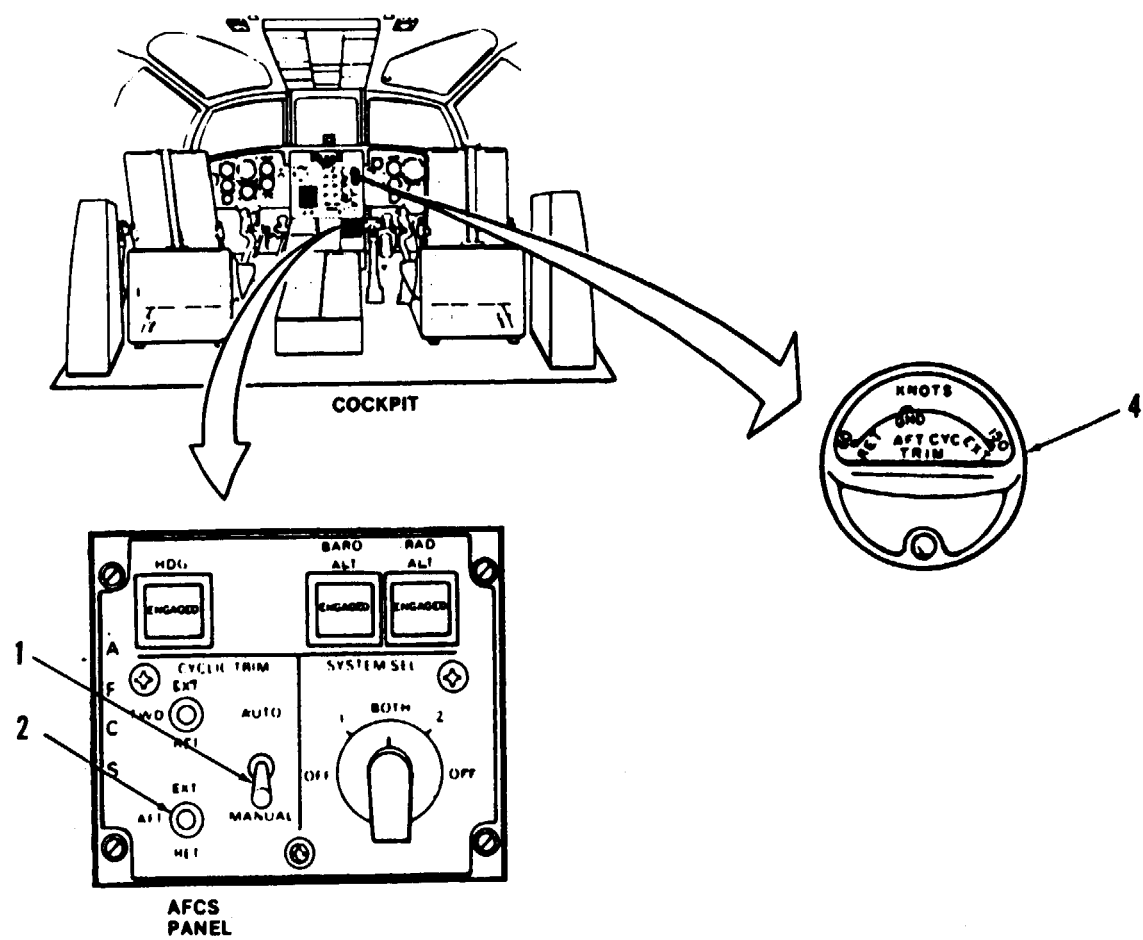

END OF TASK

11-3.34.3 LCT ACTUATOR CONTROL TRANSISTOR BVRNS OUT

INITIAL SETUP

Applicable Configurations:
All

Tools:
None

Materials:
None

Personnel Required:
Aircraft Electrician
Medium Helicopter Repairer

References:
TM 55-1520-240-23

Equipment Condition
TM 55-1520-240-23
Buttery Disconnected
Electrical Power Off
Hydraulic Power Off
Work Platform Open

TASK	RESULT
1. Perform forward and aft LCT actuator operational checks (Tasks 11-3.34.1 and 11-3.34.2).	
2. Inspect forward and aft LCT actuators.	Replace LCT actuators as required (TM 55-1520-240-23).
3. Inspect helicopters wires and connectors for damage and contamination (TASK 11-3.1).	

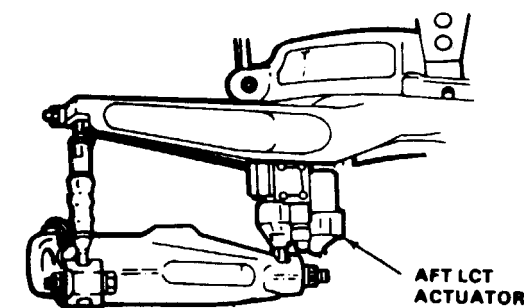
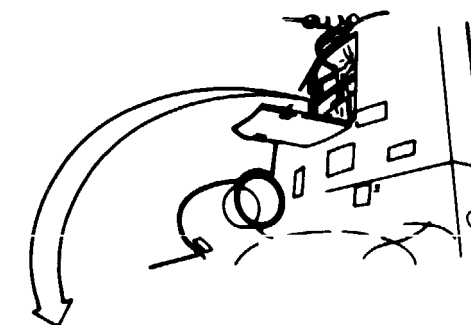
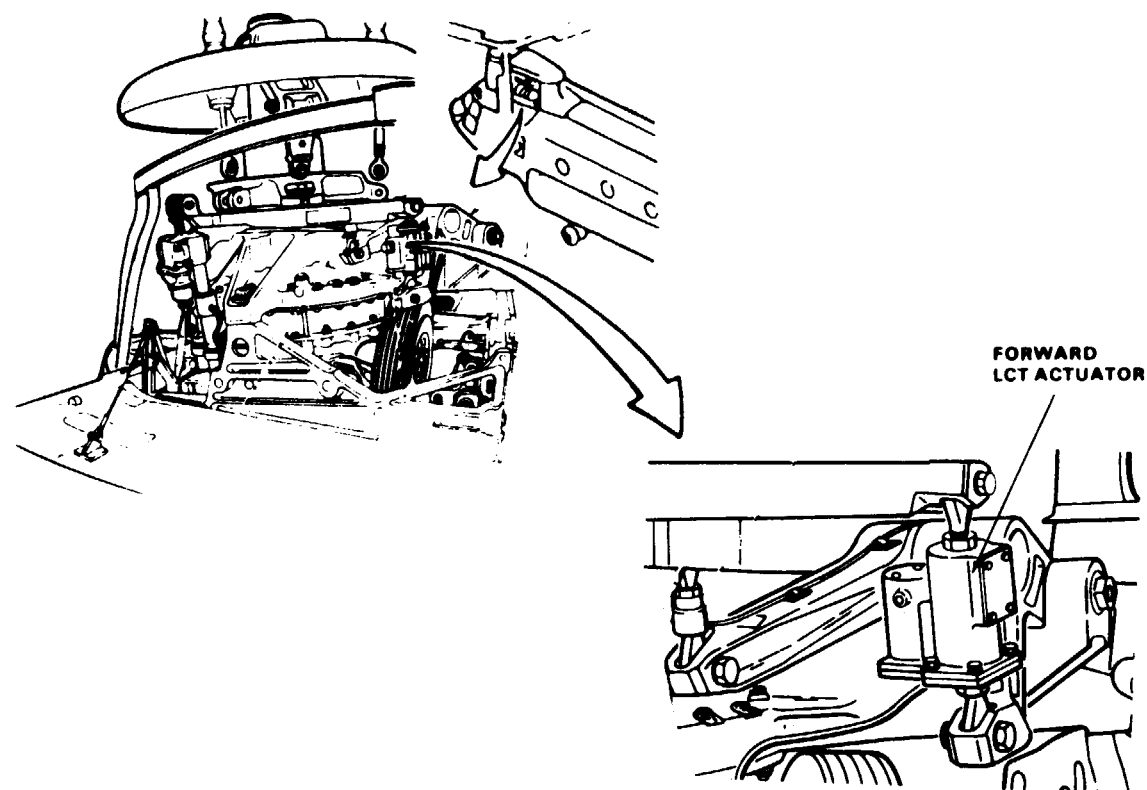

END OF TASK

11-3.35 FORWARD LCT INDICATOR DOES NOT INDICATE EXTEND OR RETRACT DURING MANUAL CONTROL (Continued)

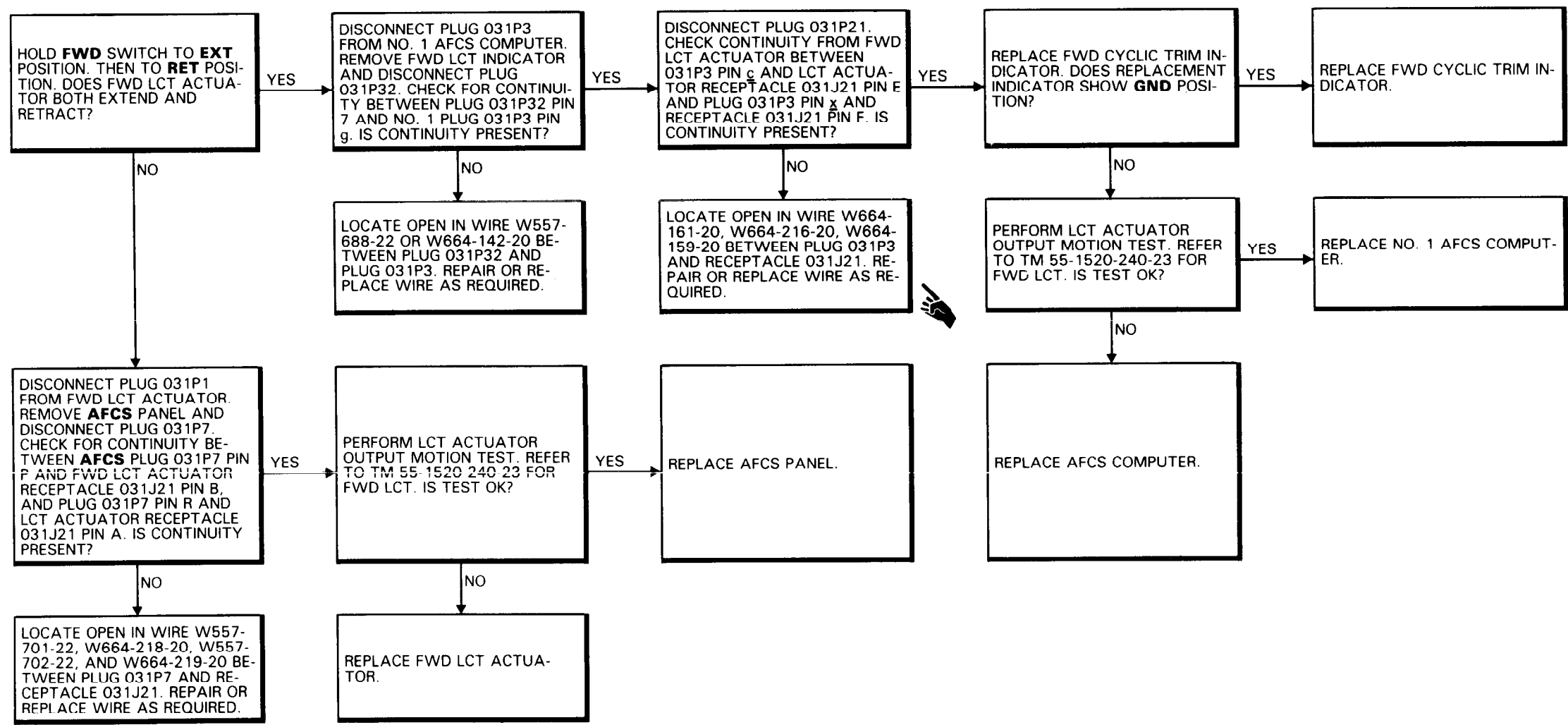

11-3.36 AFT LCT INDICATOR DOES NOT INDICATE EXTEND OR RETRACT DURING MANUAL CONTROL

FAULT ISOLATION PROCEDURE

INITIAL SETUP

Applicable Configurations:

All

Personnel Required:

38K10 Avionic Mechanic
35K20 Avionic Mechanic

Tools:

Electrical Repairer's Tool Kit,
NSN 5180-00-323-4915
Multimeter

References:

TM 55-1520-240-23

Equipment Condition:

TM 55-1520-240-23
Battery Connected
Electrical Power On
Hydraulic Power Off

Materials:

None

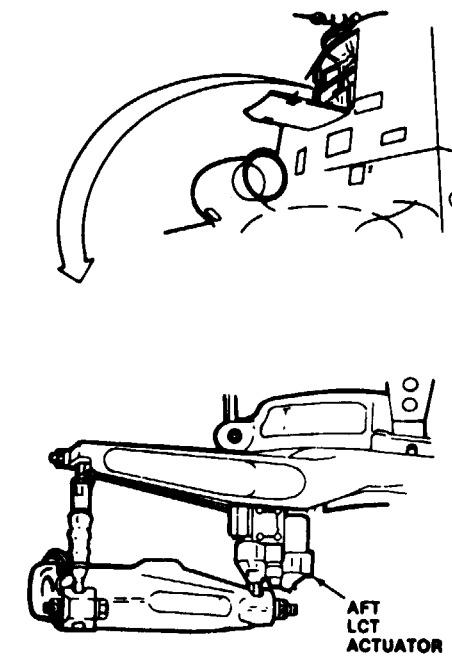
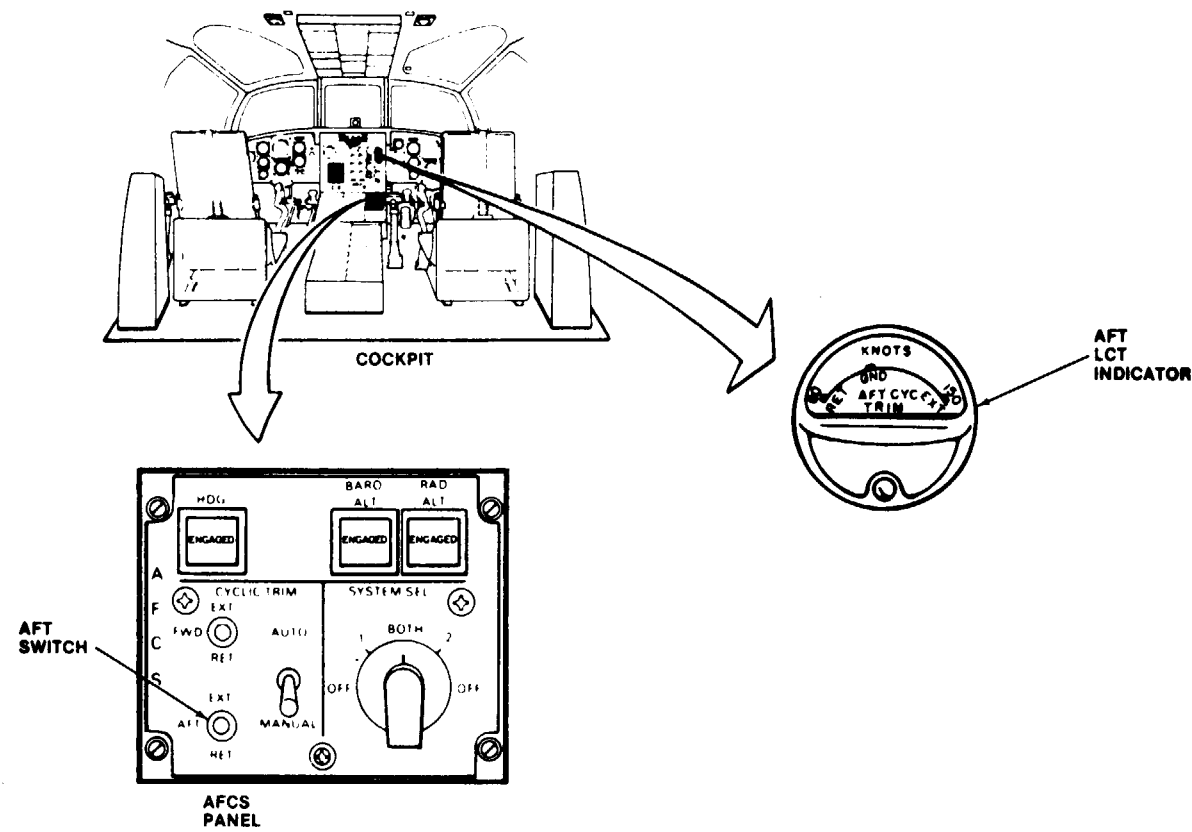
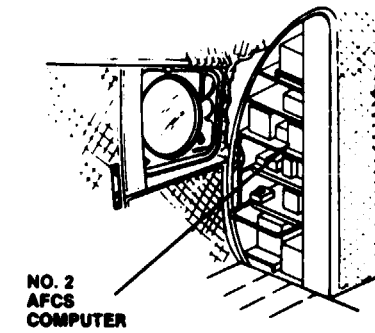

90+34

D145-11920-5PA

11-3.36 AFT LCT INDICATOR DOES NOT SHOW EXTENSION OR RETRACTION IN MANUAL CONTROL
(Continued)

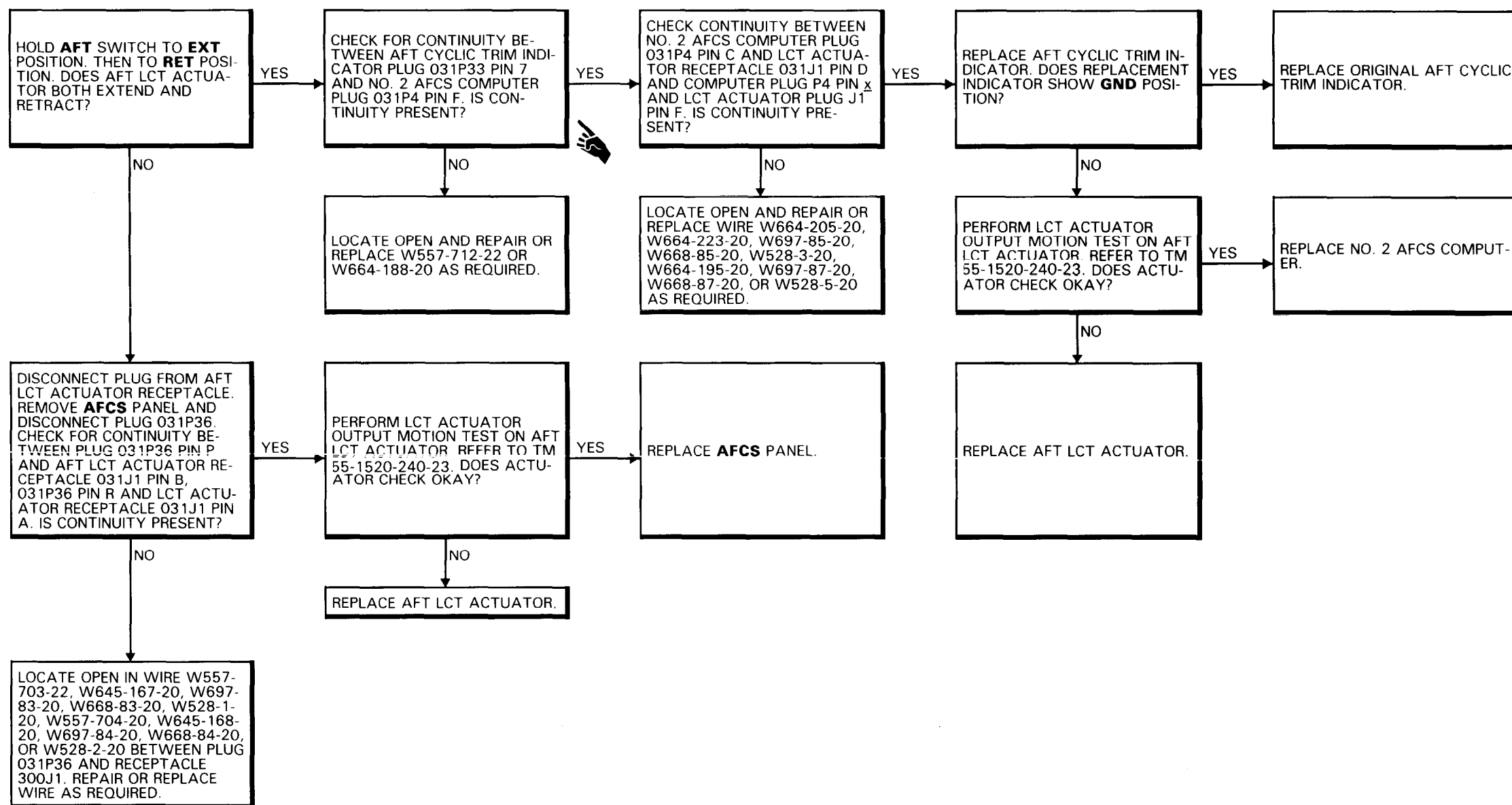

FAULT ISOLATION PROCEDURE

INITIAL SETUP

Applicable Configurations:

All

Personnel Required:

35K10 Avionic Mechanic
36K20 Avionic Mechanic

Tools:

Electrical Repairer's Tool Kit,
NSN 5180-00-323-4915
Multimeter

References:

TM 55-1520-240-23

Equipment Condition

TM 55-1520-240-23
Battery Connected
Electrical Power On
Hydraulic Power Off

Materials:

None

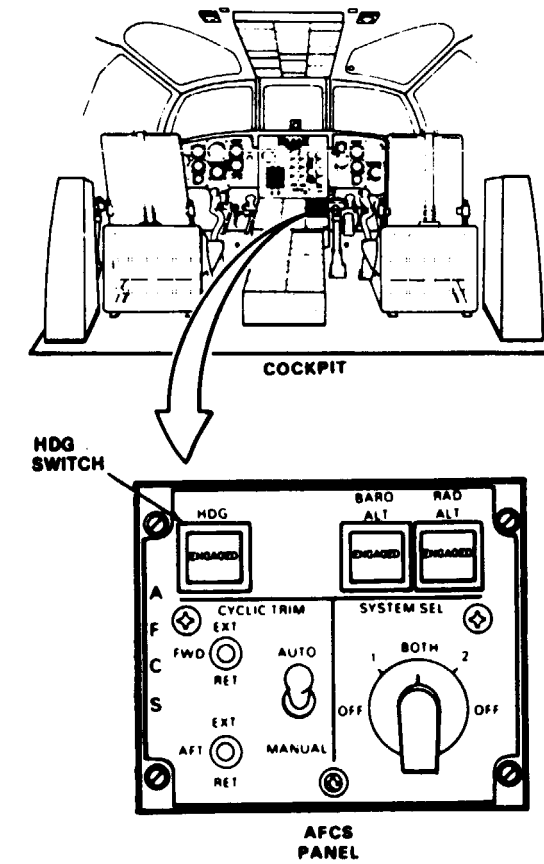
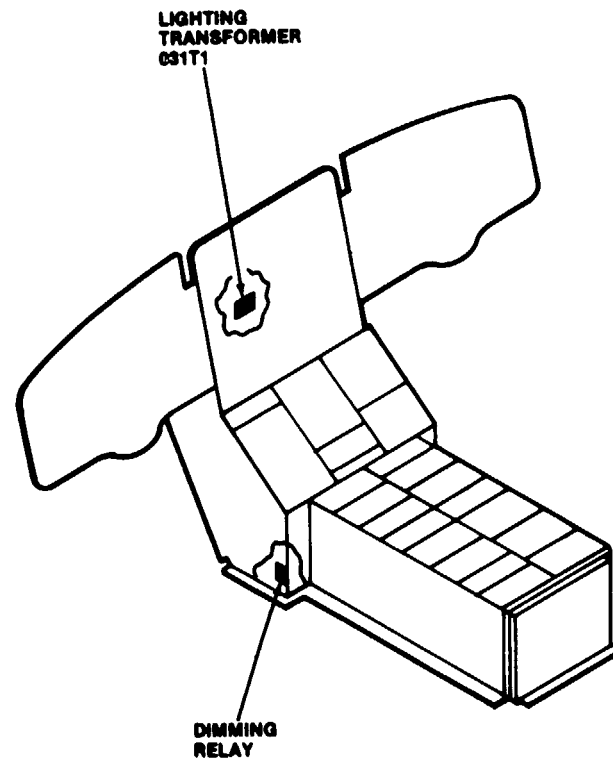

11-3.37 HDG SWITCH ENGAGED CAPTION DOES NOT LIGHT (Continued)

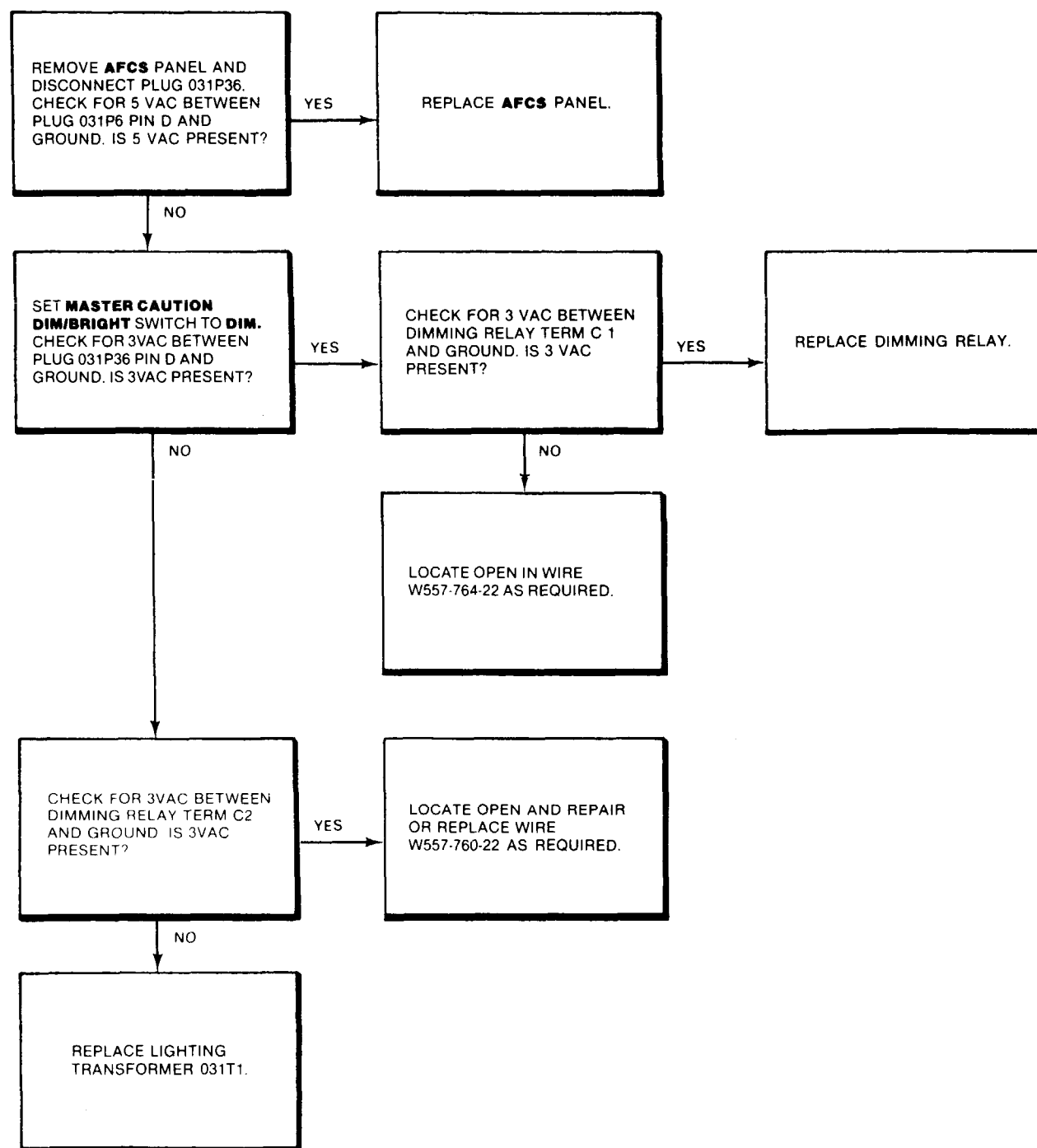

END OF TASK

11-3.38 RADAR OR BARO ALT ENGAGED CAPTIONS DO NOT COME ON WHEN PRESSED

FAULT ISOLATION PROCEDURE

INITIAL SETUP

Personnel Required:

- 35K10 Avionic Mechanic
- 35K20 Avionic Mechanic

Applicable Configurations:

All

References:

TM 55-1520-240-23

Tools:

- Electrical Repairer's Tool Kit,
NSN 5180-00-323-4915
- Multimeter

Equipment Condition:

- TM 55-1520-240-23
- Battery Connected
- Electrical Power On
- Hydraulic Power Off

Materials:

None

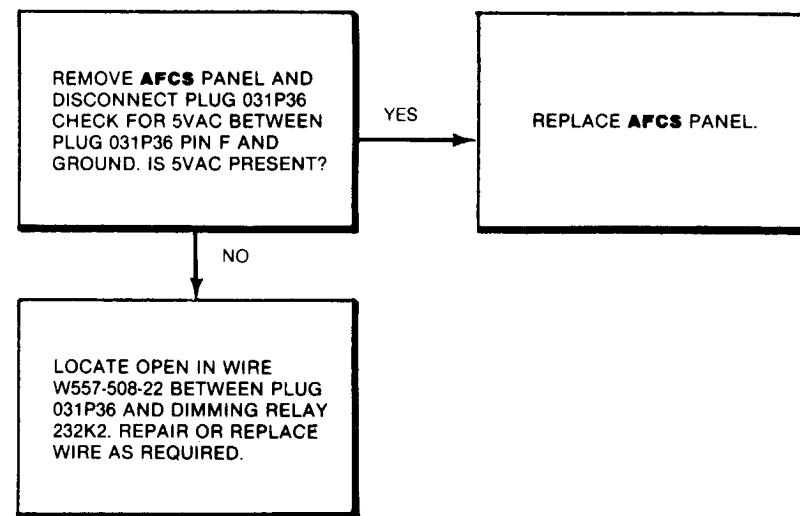
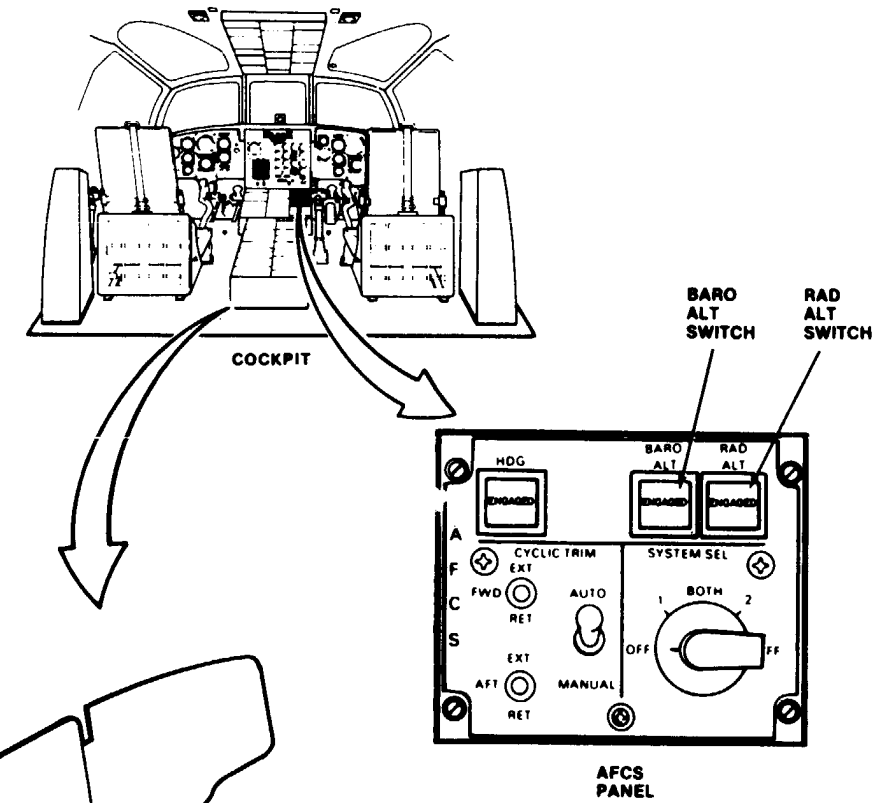

45X54

D145-11930-SPA

END OF TASK

FAULT ISOLATION PROCEDURE

INITIAL SETUP

Applicable Configurations:

All

Tools:

Electrical Repairer's Tool Kit,
NSN 5180-00-323-4915
Multimeter

Materials:

None

Personnel Required:

Avionic Mechanic (2)

References:

TM 55-1520-240-23

Equipment Condition:

TM 55-1520-240-23:
Battery Connected
Electrical Power On
Hydraulic Power Off

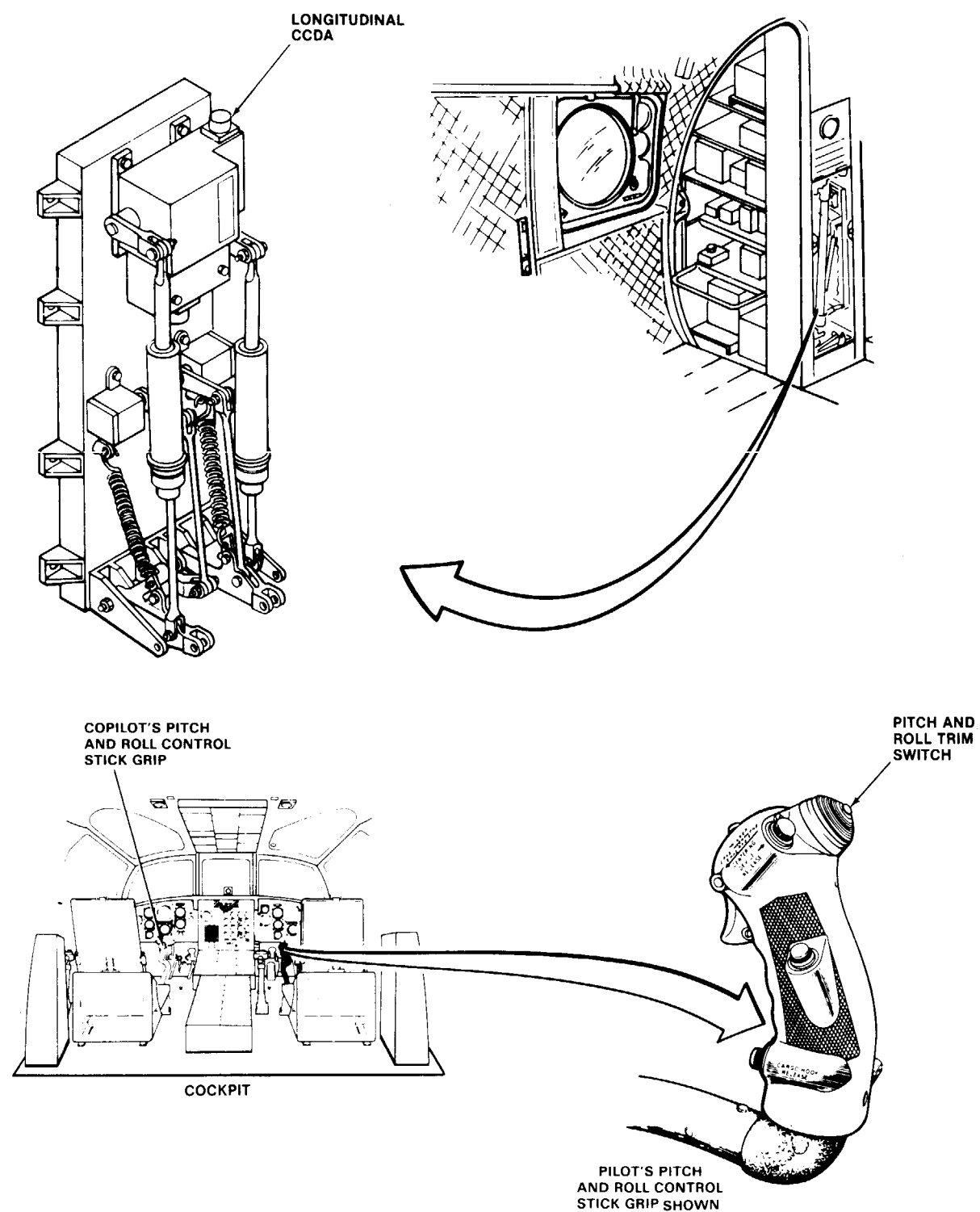

11-3.39 PITCH AND ROLL CONTROL STICK DOES NOT MOVE FORWARD OR AFT WHEN PILOT'S OR COPILOT'S PITCH AND ROLL TRIM SWITCH IS MOVED FORWARD AND AFT (Continued)

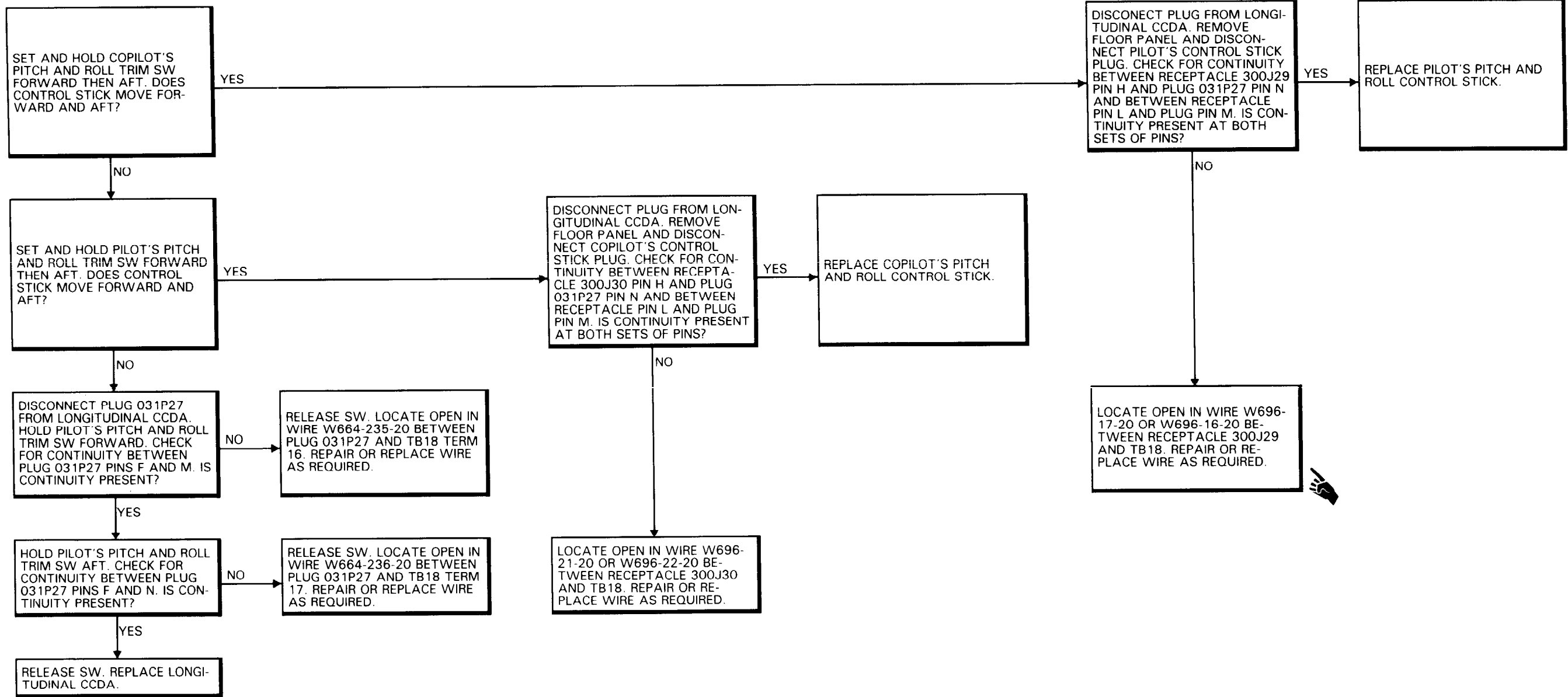

FAULT ISOLATION PROCEDURE

INITIAL SETUP

Applicable Configurations:

All

Tools:

Electrical Repairer's Tool Kit,
NSN 5180-00-323-4915
Multimeter

Materials:

None

Personnel Required:

35K10 Avionic Mechanic
35K20 Avionic Mechanic

References:

TM 55-1520-240-23

Equipment Condition:

TM 55-1520-240-23
Battery Connected
Electrical Power On
Hydraulic Power On

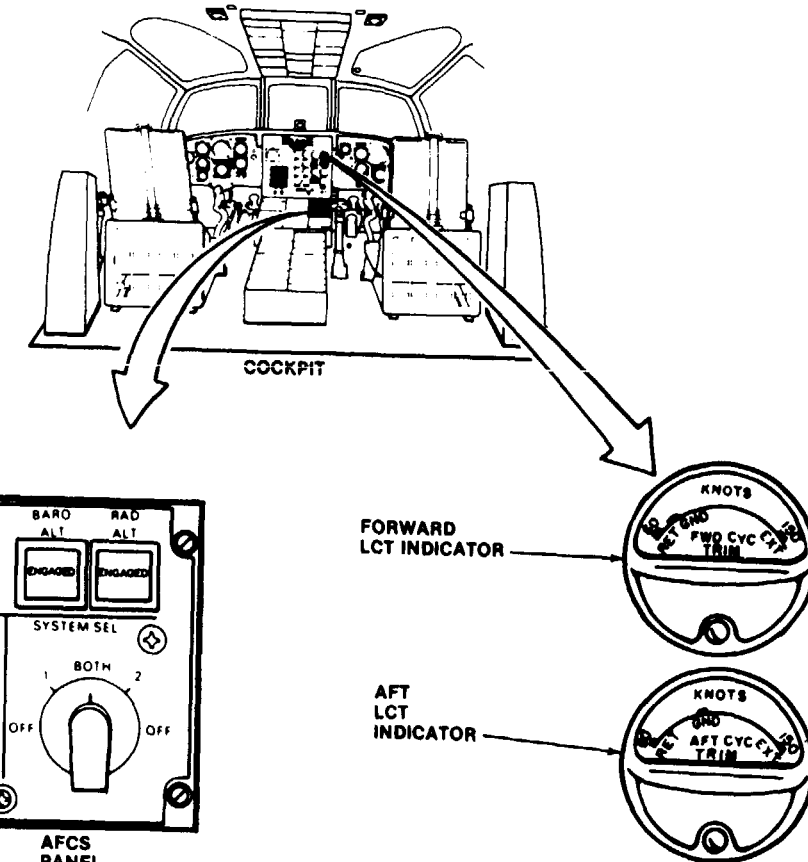
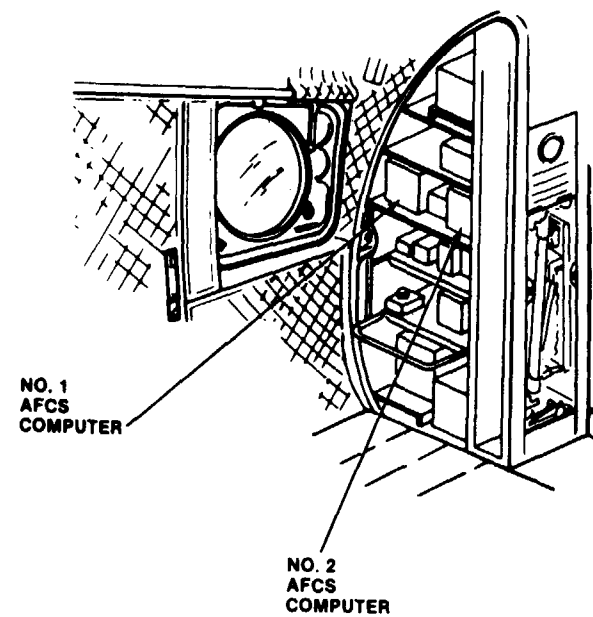

90 X 54

D145-11932-SPA

NO. 1 AFCS COMPUTER BITE INDICATES 6, 9, OR 18.

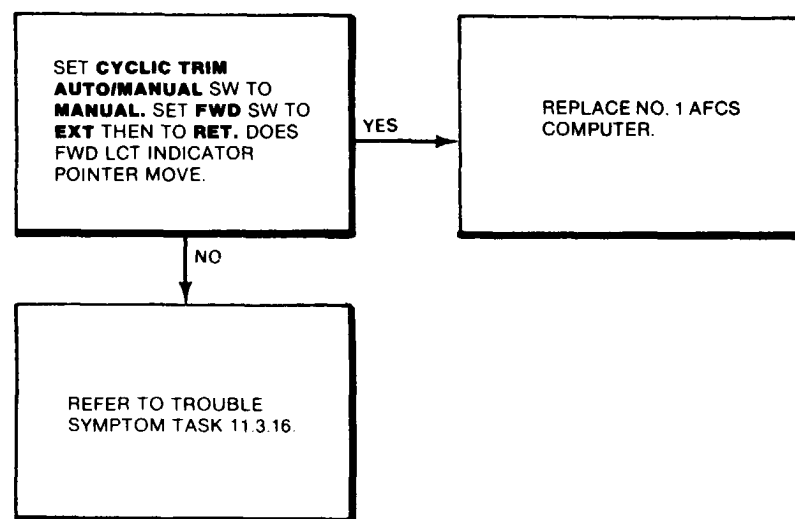

NO. 2 AFCS COMPUTER BITE INDICATES 6, 9, OR 18.

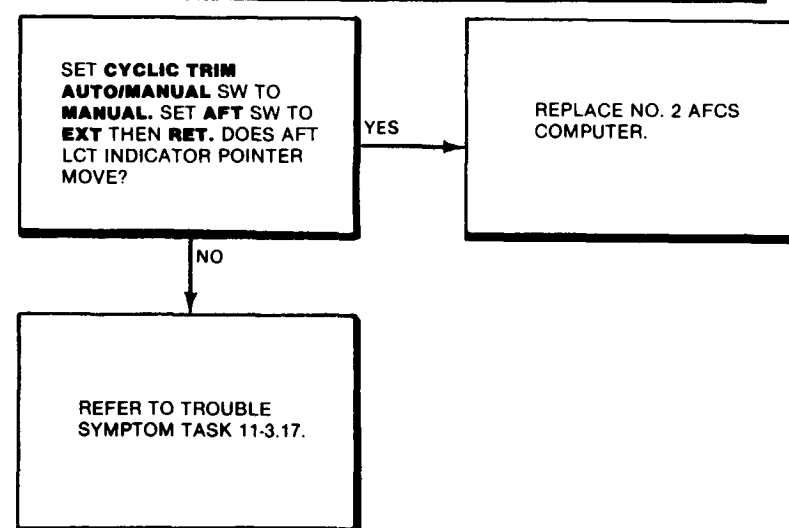

FAULT ISOLATION PROCEDURE

INITIAL SETUP

Applicable Configurations:

All

Tools:

- Electrical Repairer's Tool Kit,
NSN 5180-00-323-4915
- Multimeter

Materials:

None

Personnel Required:

- 35K10 Avionic Mechanic
- 35K20 Avionic Mechanic

References:

- TM 55-1520-240-23
- TM 55-4920-429-13

Equipment Condition:

- TM 55-1520-240-23
- Battery Connected
- Electrical Power On
- Hydraulic Power On
- TM 55-4920-429-13
- AFCS Line Test Set 145G0009-1
- Prepared for Use

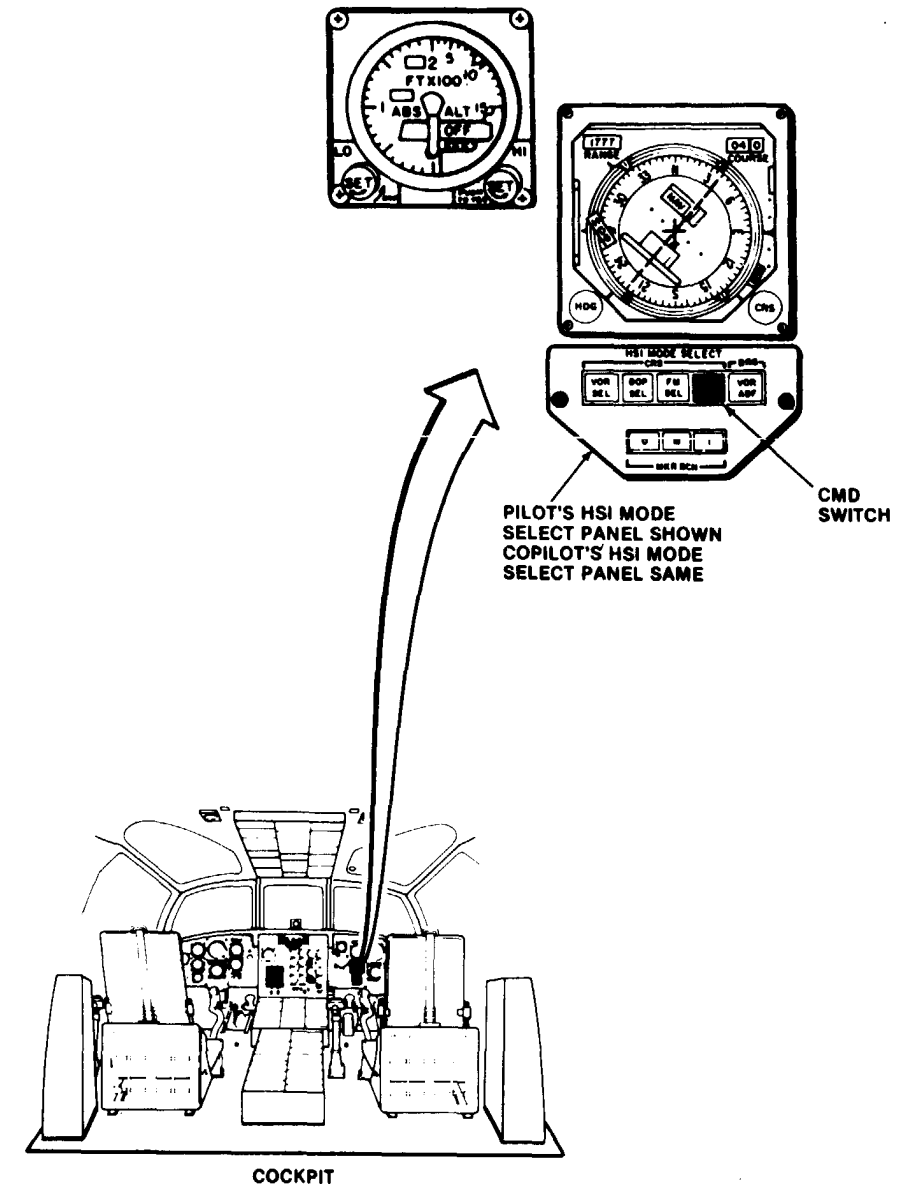
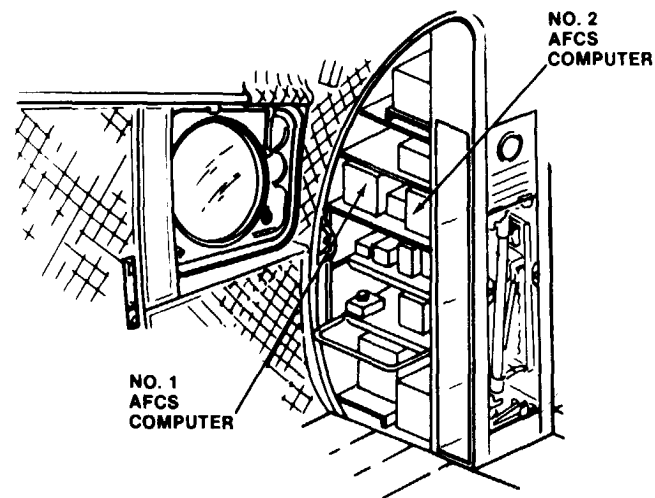

NO. 1 AFCS COMPUTER BITE INDICATES 48

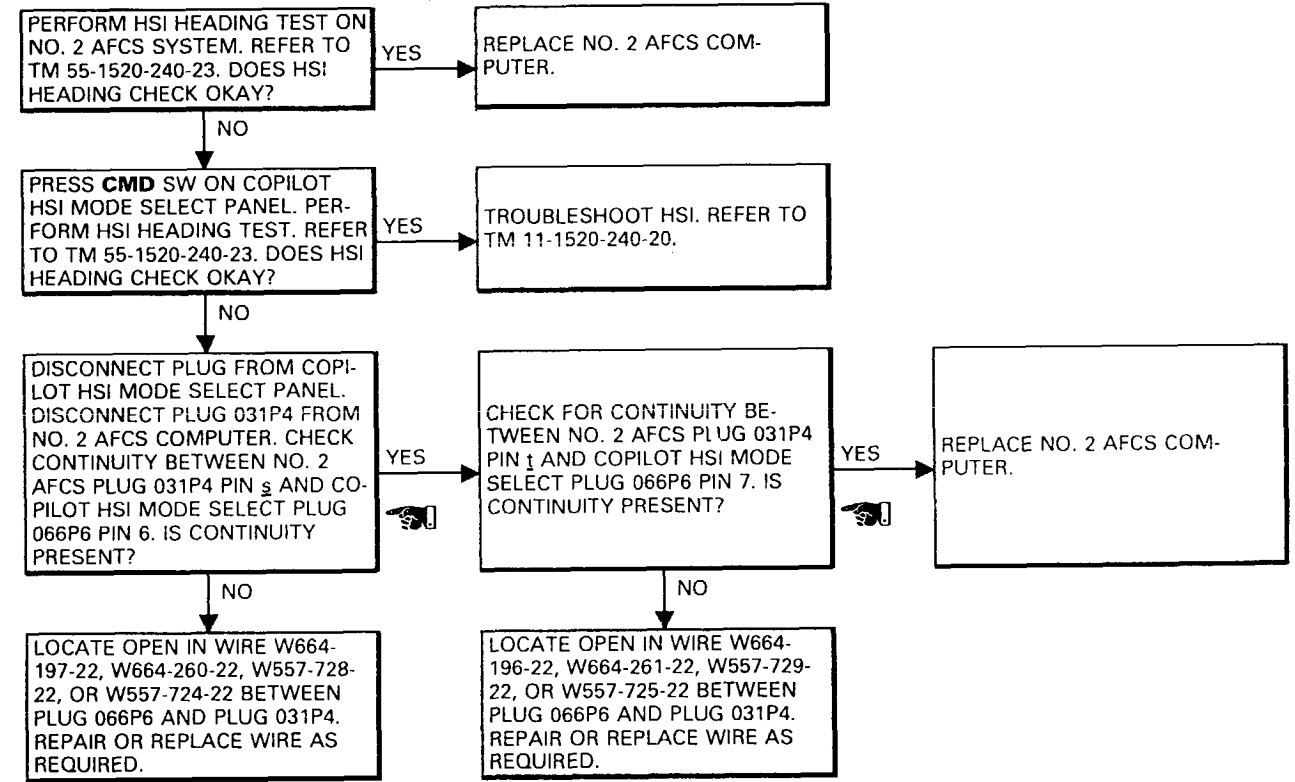
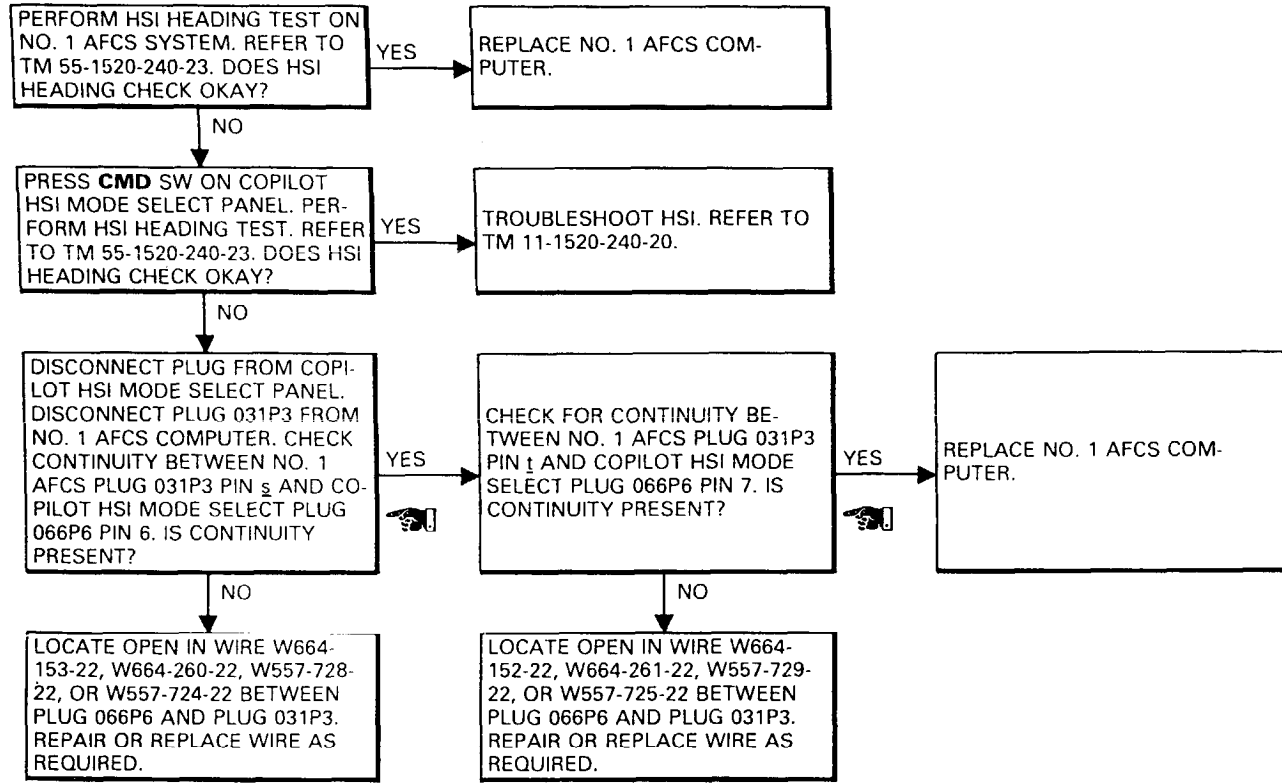

FAULT ISOLATION PROCEDURE

INITIAL SETUP

Applicable Configurations:
All

Tool:
Electrical Repairer's Tool Kit,
NSN 5180-00-323-4915
Multimeter

Materials:
None

Personnel Required:
35K10 Avionic Mechanic
35K20 Avionic Mechanic

References:
TM 55-1520-240-23
TM 55-4920-429-13

Equipment Condition:
TM 55-1520-240-23
Battery Connected
Electrical Power On
Hydraulic Power On
TM 55-4920-429-13
AFCS Line Test Set 145G0009-1
Prepared for Use

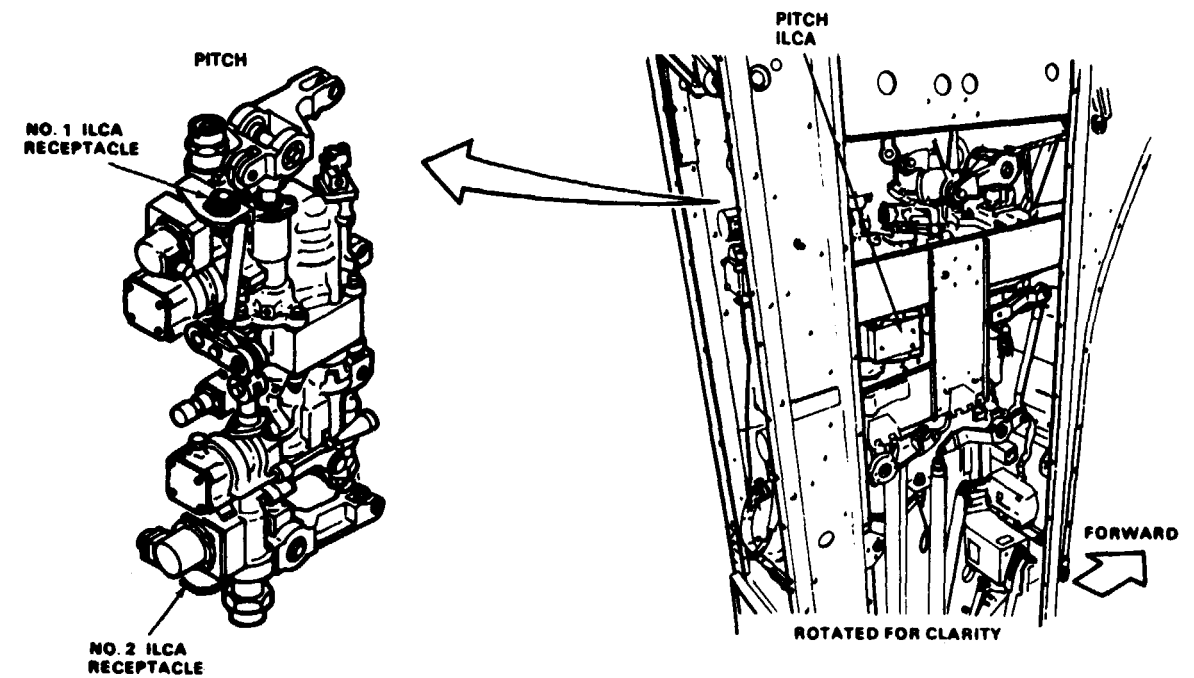
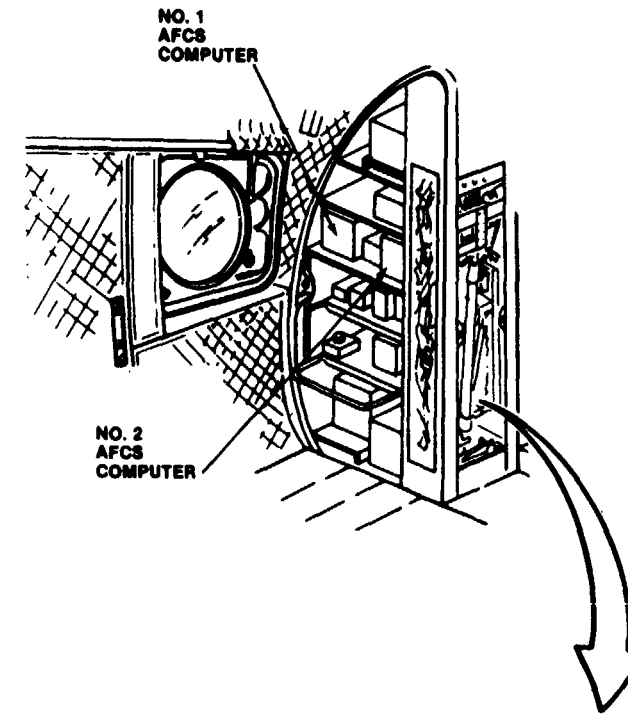

48 x 84

DMS-11960-8PM

GO TO NEXT PAGE

NO. 1 AFCS COMPUTER BITE INDICATES 70-74.

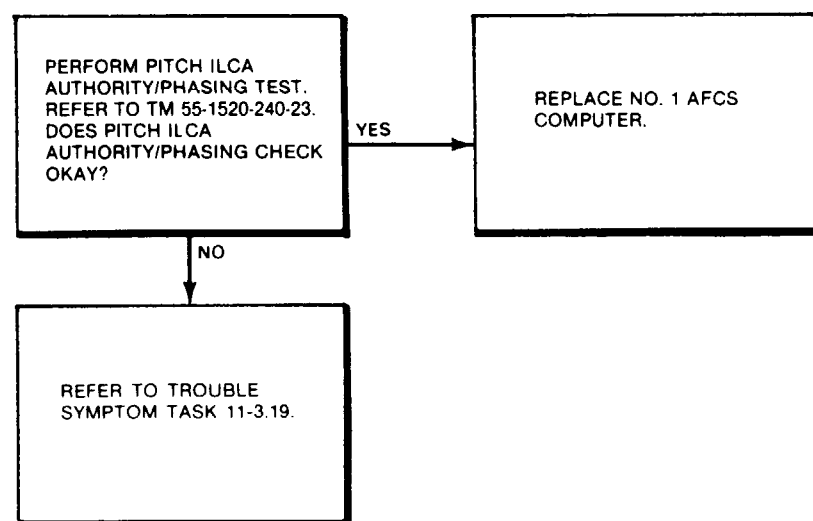

NO. 2 AFCS COMPUTER BITE INDICATES 70-74.

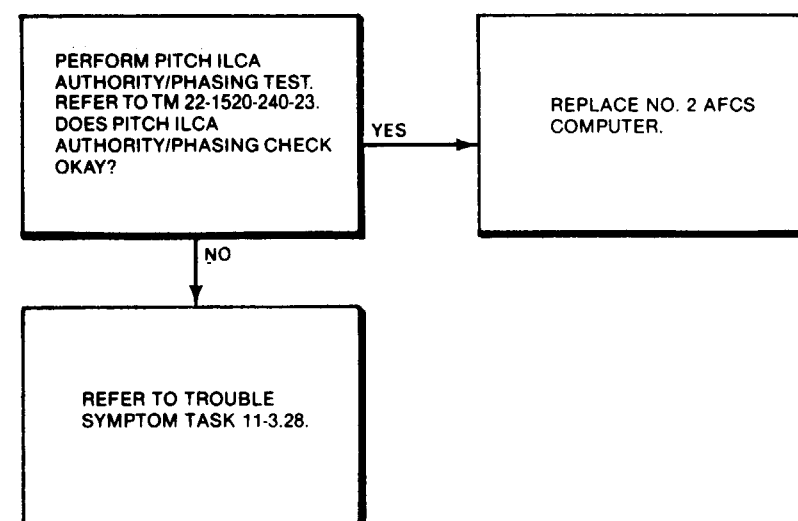

FAULT ISOLATION PROCEDURE

INITIAL SETUP

Applicable Configurations:

All

Tools:

Electrical Repairer's Tool Kit,
NSN 5180-00-323-4915
Multimeter

Materials:

None

Personnel Required

35K10 Avionic Mechanic
35K20 Avionic Mechanic

References:

TM 55-1520-240-23
TM 55-4920-429-13

Equipment Condition:

TM 55-1520-240-23
Battery Connected
Electrical Power On
Hydraulic Power On
TM 55-4920-429-13
AFCS Line Test Set 145G0009-1
Prepared for Use

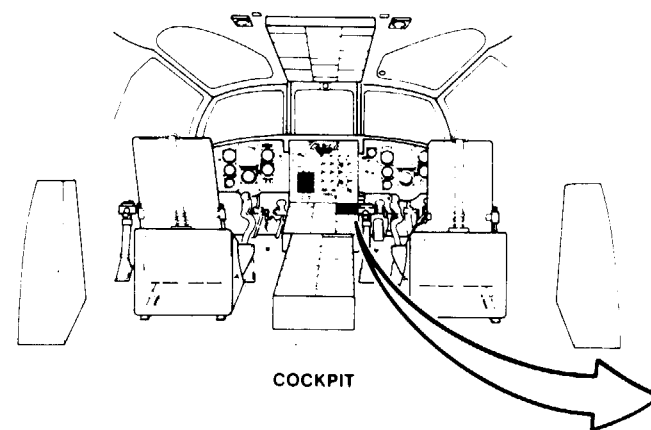

COCKPIT

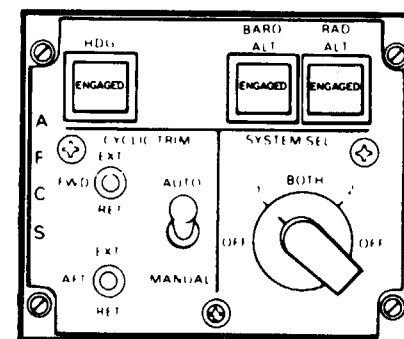

AFCS PANEL

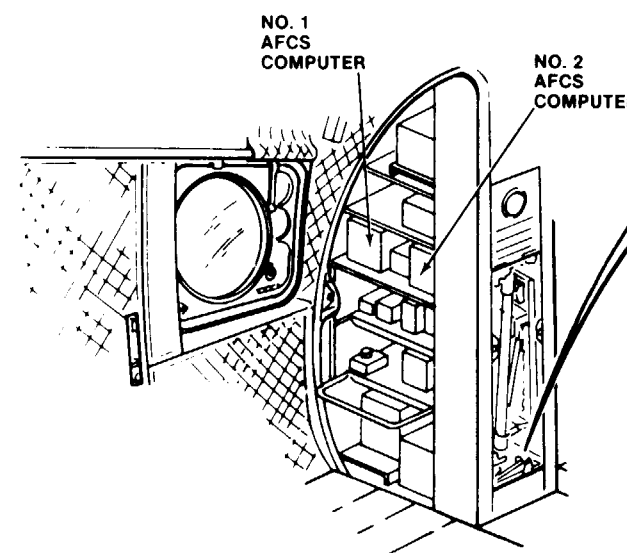

NO. 1 AFCS COMPUTER

NO. 2 AFCS COMPUTER

DASH ACTUATOR

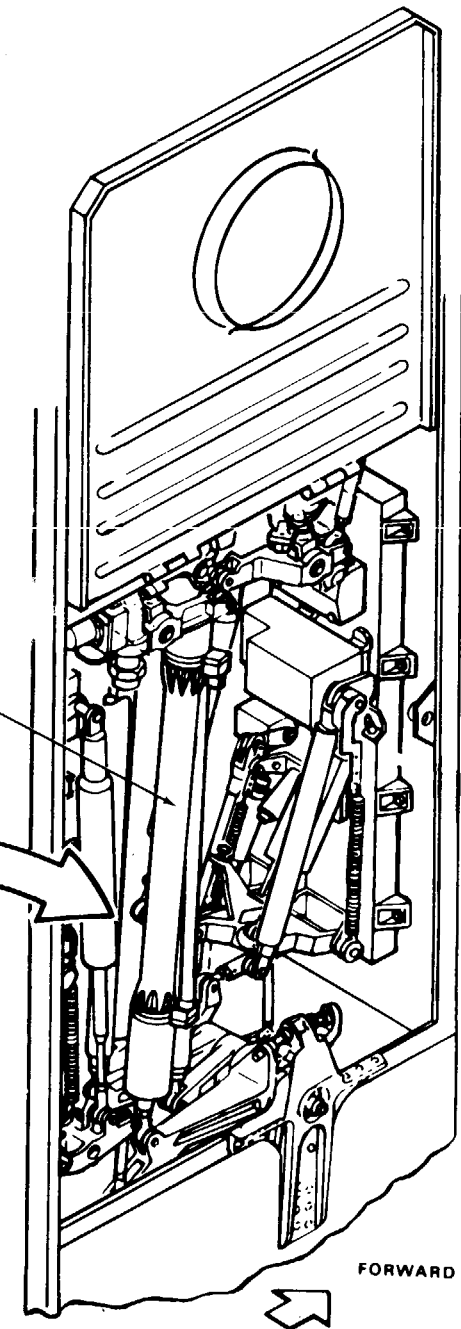

FORWARD

FLIGHT CONTROLS CLOSET

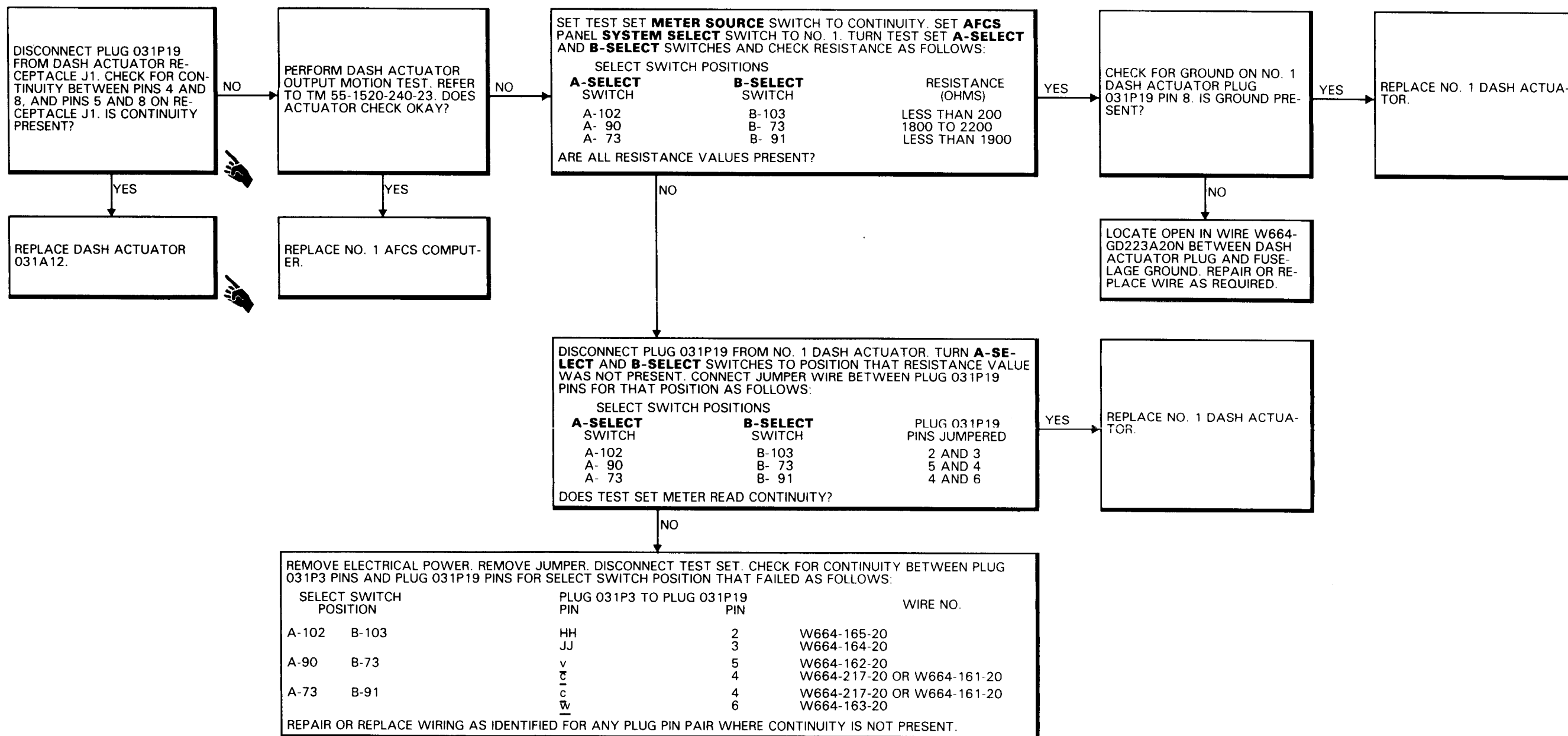

11-3.44 NO. 2 AFCS COMPUTER BITE INDICATES 85 OR 86

FAULT ISOLATION PROCEDURE

INITIAL SETUP

Applicable Configurations:

All

Tools:

- Electrical Repairer's Tool Kit,
NSN 5180-00-323-4915
- Multimeter

Materials:

None

Personnel Required:

- 35K10 Avionic Mechanic
- 35K20 Avionic Mechanic

References:

- TM 55-1520-240-23
- TM 55-4920-429-13

Equipment Condition:

- TM 55-1520-240-23
- Battery Connected
- Electrical Power On
- Hydraulic Power On
- TM 55-4920-429-13
- AFCS Line Test Set 145G0009-1
- Prepared for Use

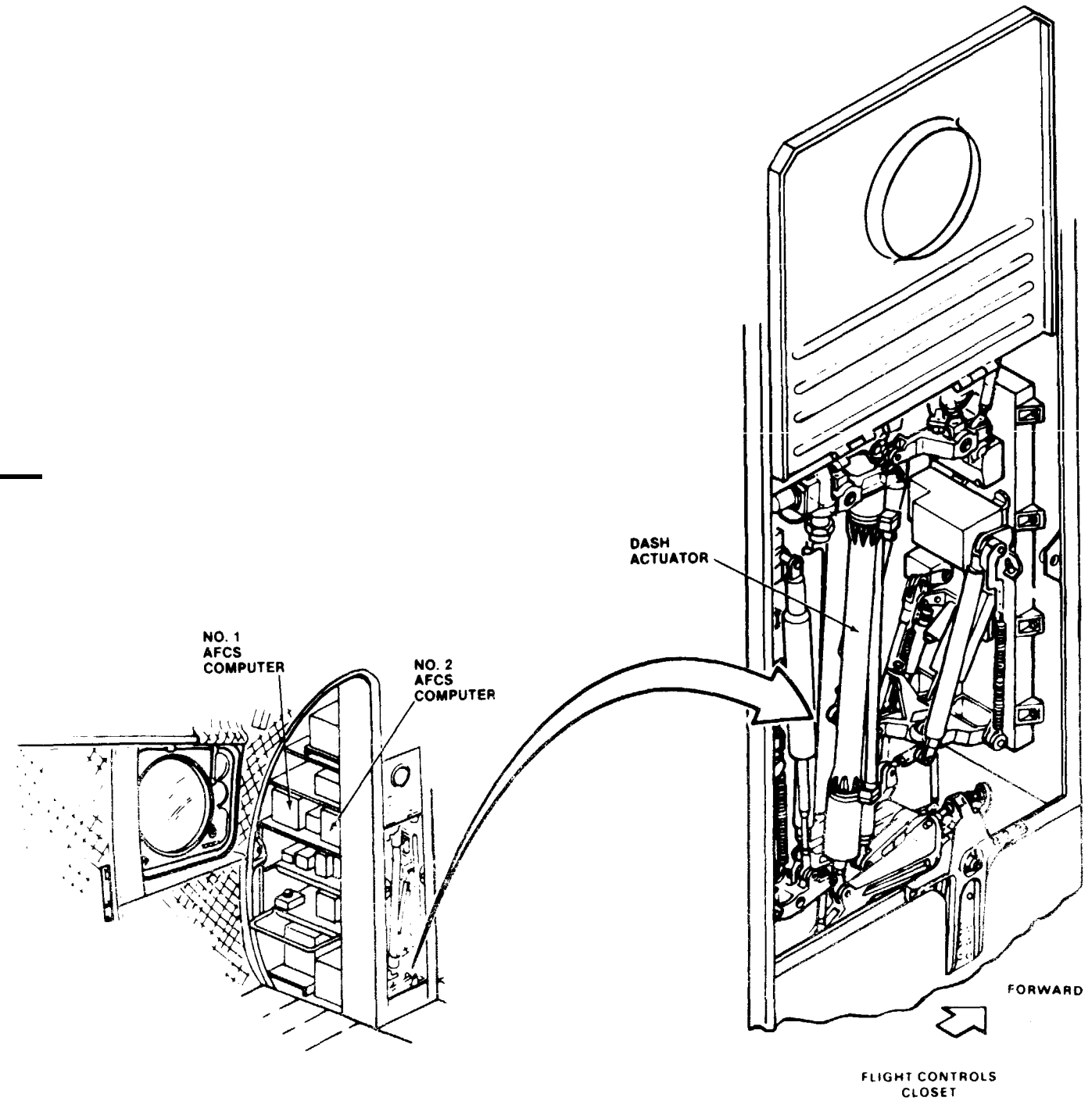
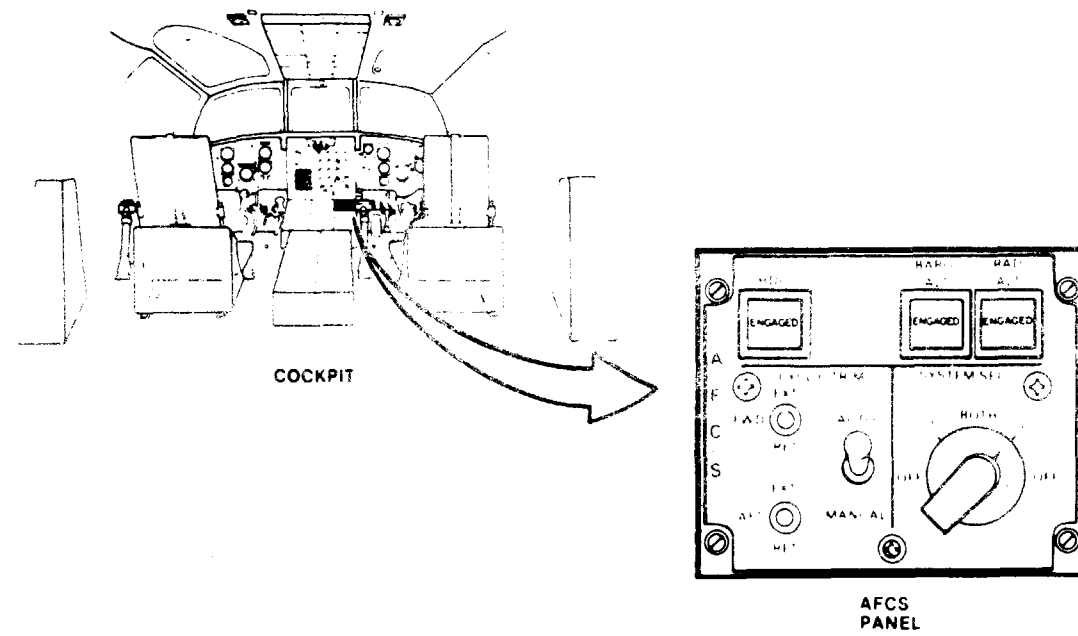

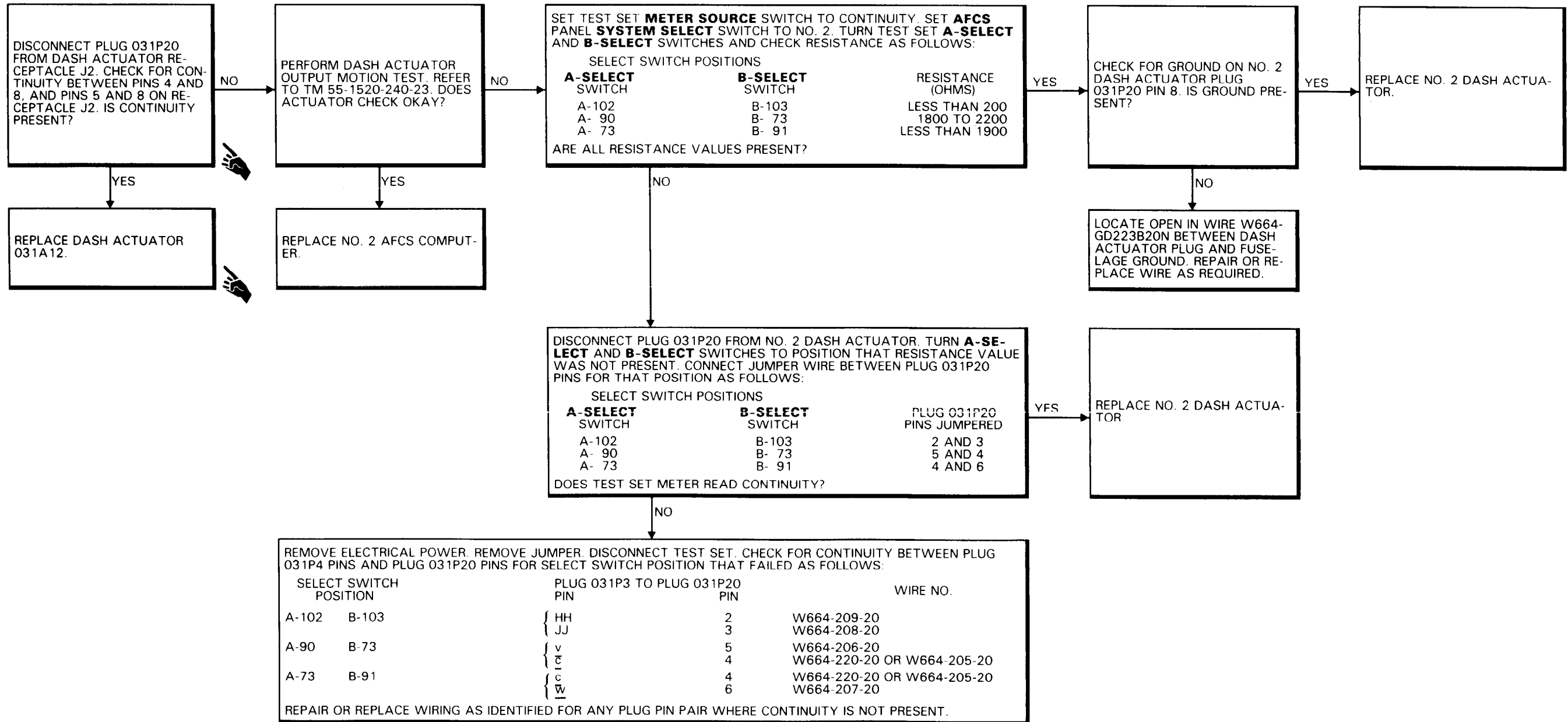

FAULT ISOLATION PROCEDURE

INITIAL SETUP

Applicable Configurations:
All

Tools:
Electrical Repairer's Tool Kit,
NSN 5180-00-323-4915
Multimeter

Materials:
None

Personnel Required:
35K10 Avionic Mechanic
35K20 Avionic Mechanic

References:

TM 55-1520-240-23
TM 55-4920-429-13

Equipment Condition:

TM 55-1520-240-23
Battery Connected
Electrical Power On
Hydraulic Power On
TM 55-4920-429-13
AFCS Line Test Set 145G0009-1
Prepared For Use

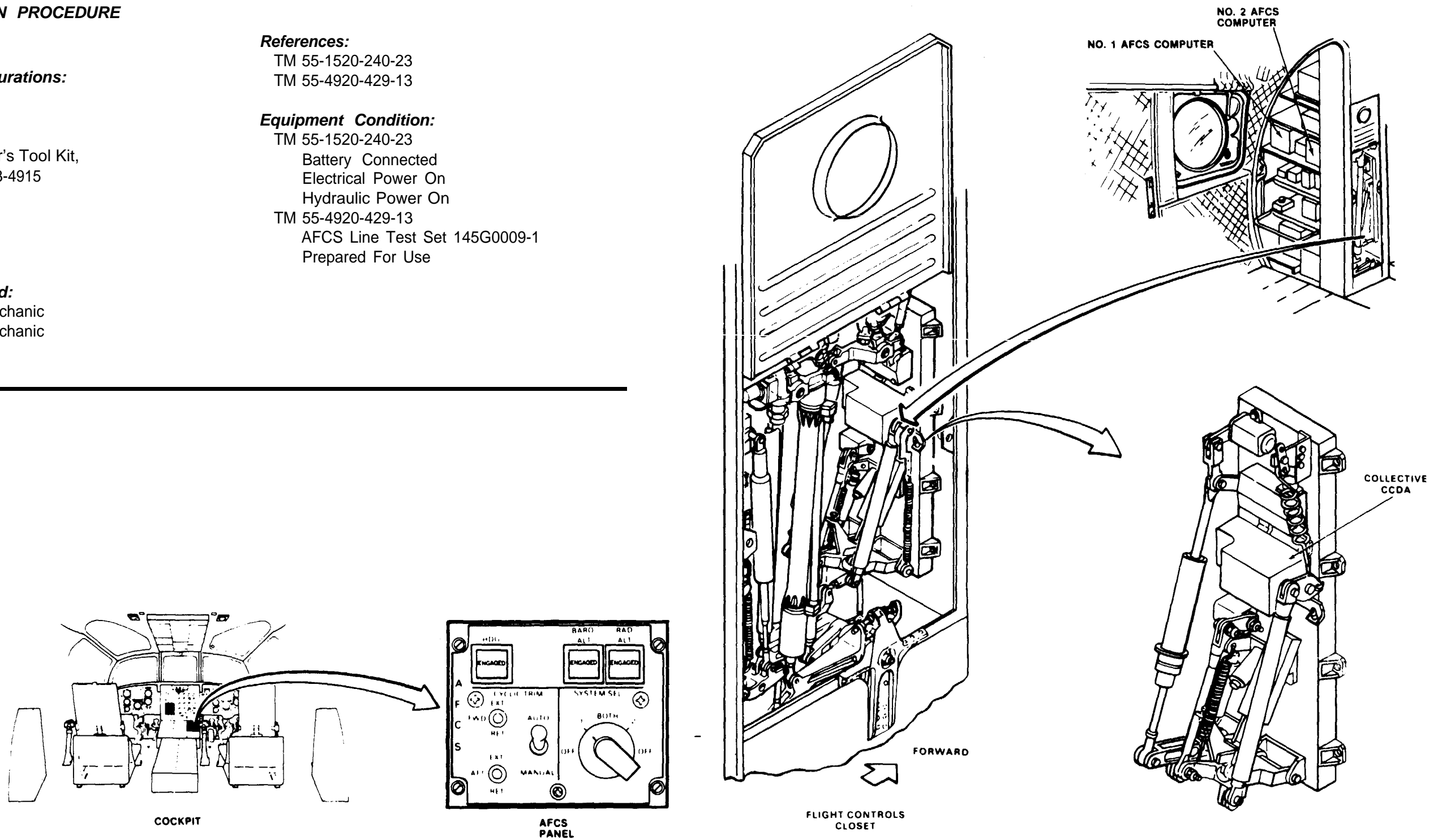

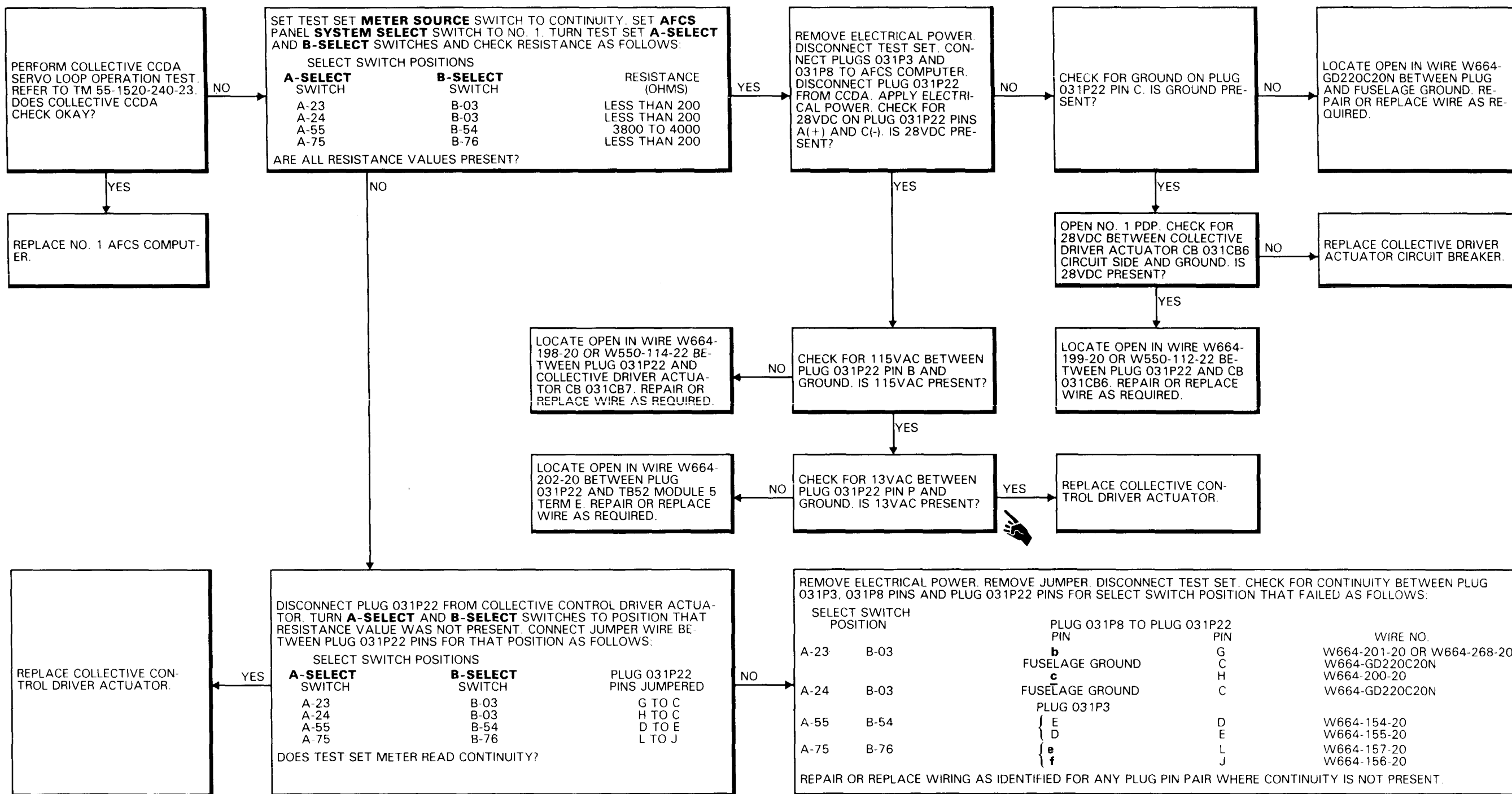

FAULT ISOLATION PROCEDURE

INITIAL SETUP

Applicable Configurations:

All

Tools:

Electrical Repairer's Tool Kit,
NSN 5180-00-323-4915
Multimeter

Materials:

None

Personnel Required:

35K10 Avionic Mechanic
35K20 Avionic Mechanic

References:

TM 55-1520-240-23
TM 55-4920-429-13

Equipment Condition:

TM 55-1520-240-23
Battery Connected
Electrical Power On
Hydraulic Power On
TM 55-4920-429-13
AFCS. Line Test Set 145G0009-1
Prepared for Use

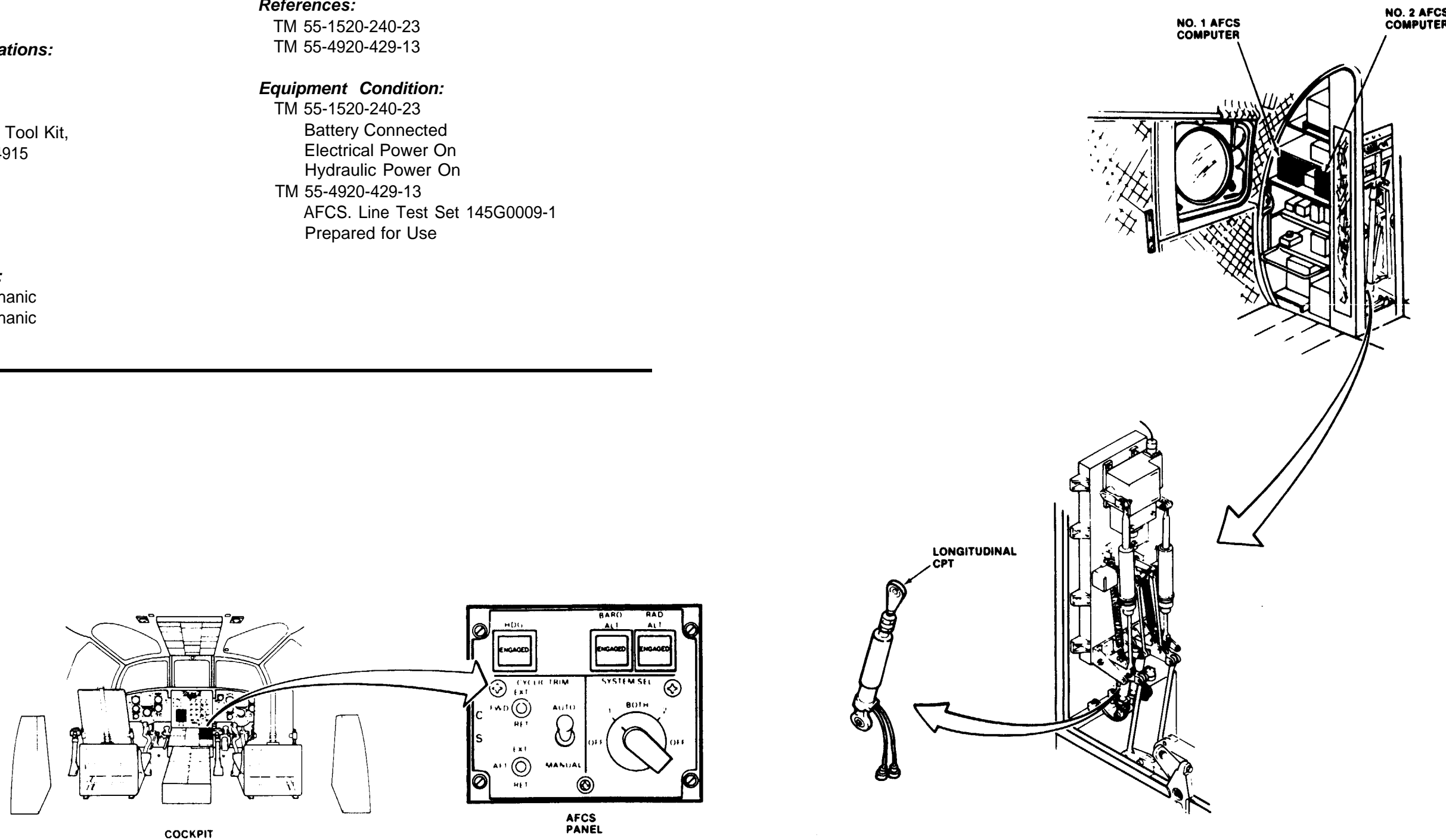

46X54

D145-11937-SPA

GO TO NEXT PAGE

11-3.46 NO. 1 AFCS COMPUTER BITE INDICATES 89 (Continued)

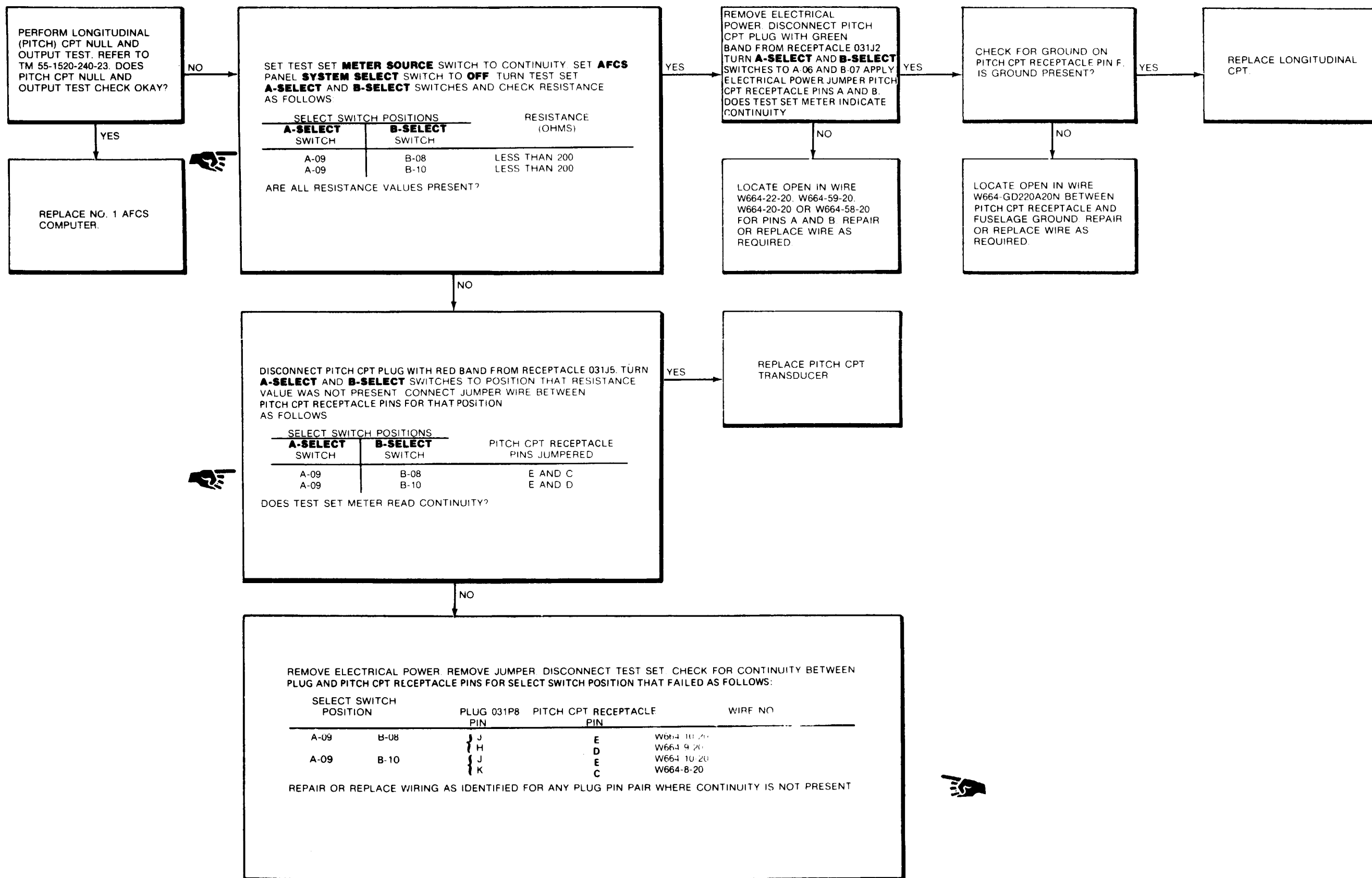

END OF TASK

FAULT ISOLATION PROCEDURE

INITIAL SETUP

Applicable Configurations:

All

Tools:

Electrical Repairer's Tool Kit,
NSN 5180-00-323-4915
Multimeter

Materials:

None

Personnel Required:

35K10 Avionic Mechanic
35K20 Avionic Mechanic

References:

TM 55-1520-240-23
TM 55-4920-429-13

Equipment Condition:

TM 55-1520-240-23
Battery Connected
Electrical Power On
Hydraulic Power On
TM 55-4920-429-13
AFCS Line Test Set 145G0009-1
Prepared for Use

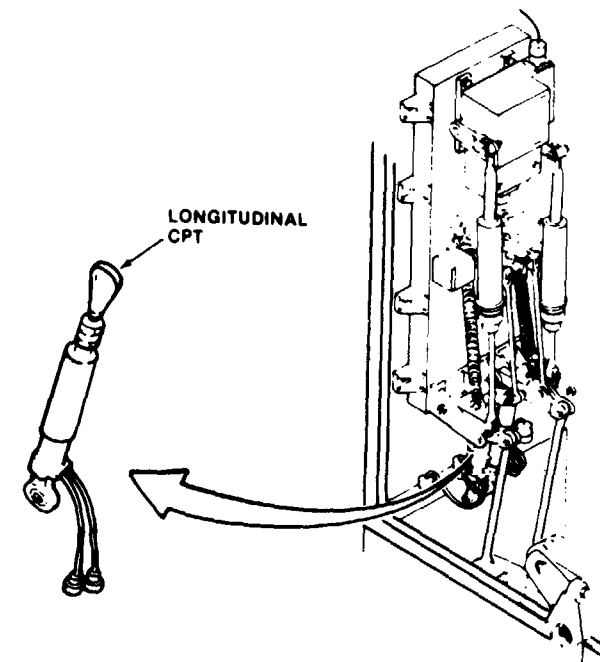
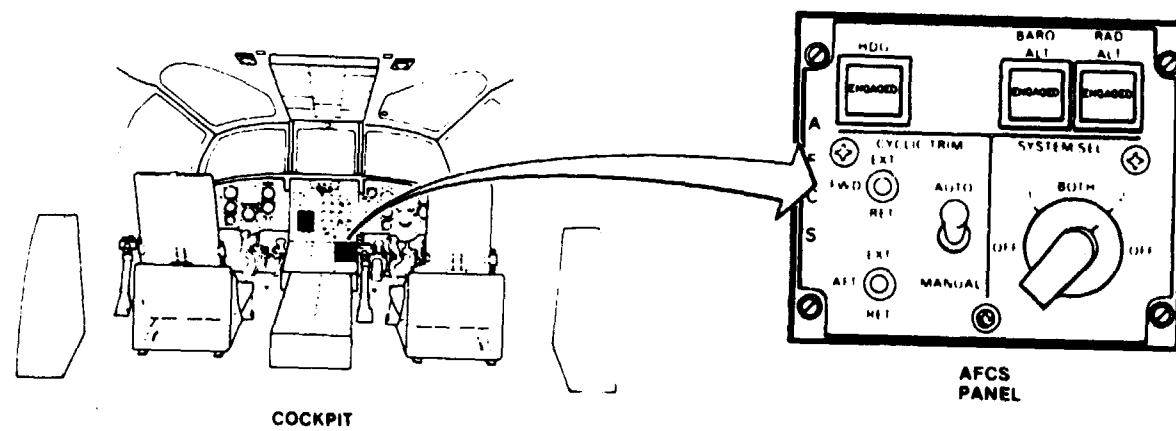
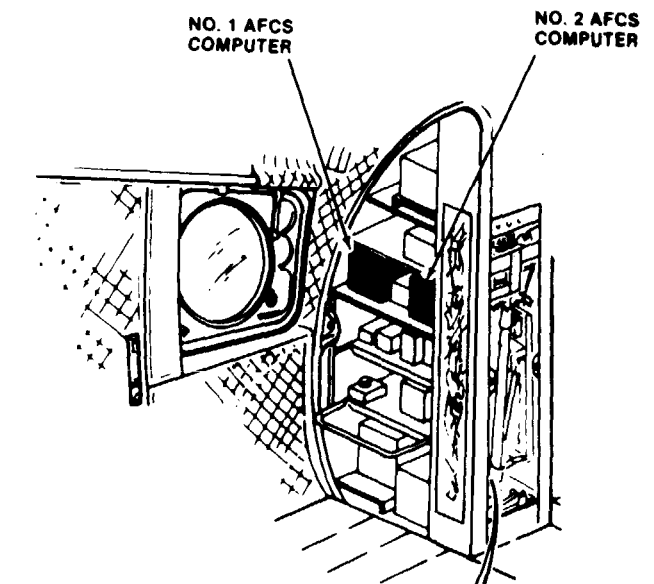

11-3.47 NO. 2 AFCS COMPUTER BITE INDICATES 89 (Continued)

11-3.47

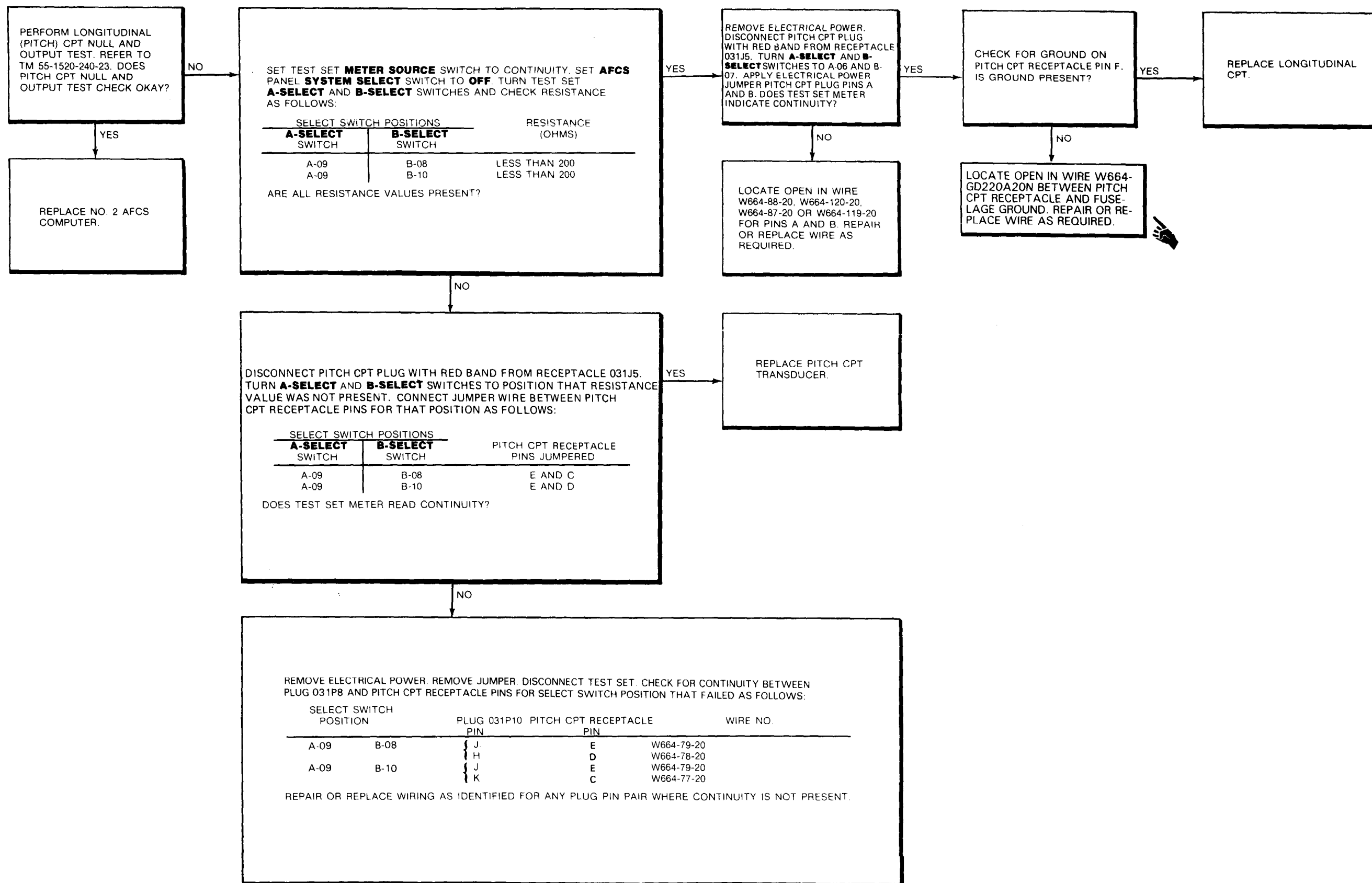

END OF TASK

FAULT ISOLATION PROCEDURE

INITIAL SETUP

Applicable Configurations:

All

Tools:

Electrical Repairer's Tool Kit,
NSN 5180-00-323-4915
Multimeter

Materials:

None

Personnel Required:

35K10 Avionic Mechanic
35K20 Avionic Mechanic

References:

TM 55-1520-240-23

Equipment Condition:

TM 55-1520-240-23
Battery connected
Electrical Power On
Hydraulic Power Off

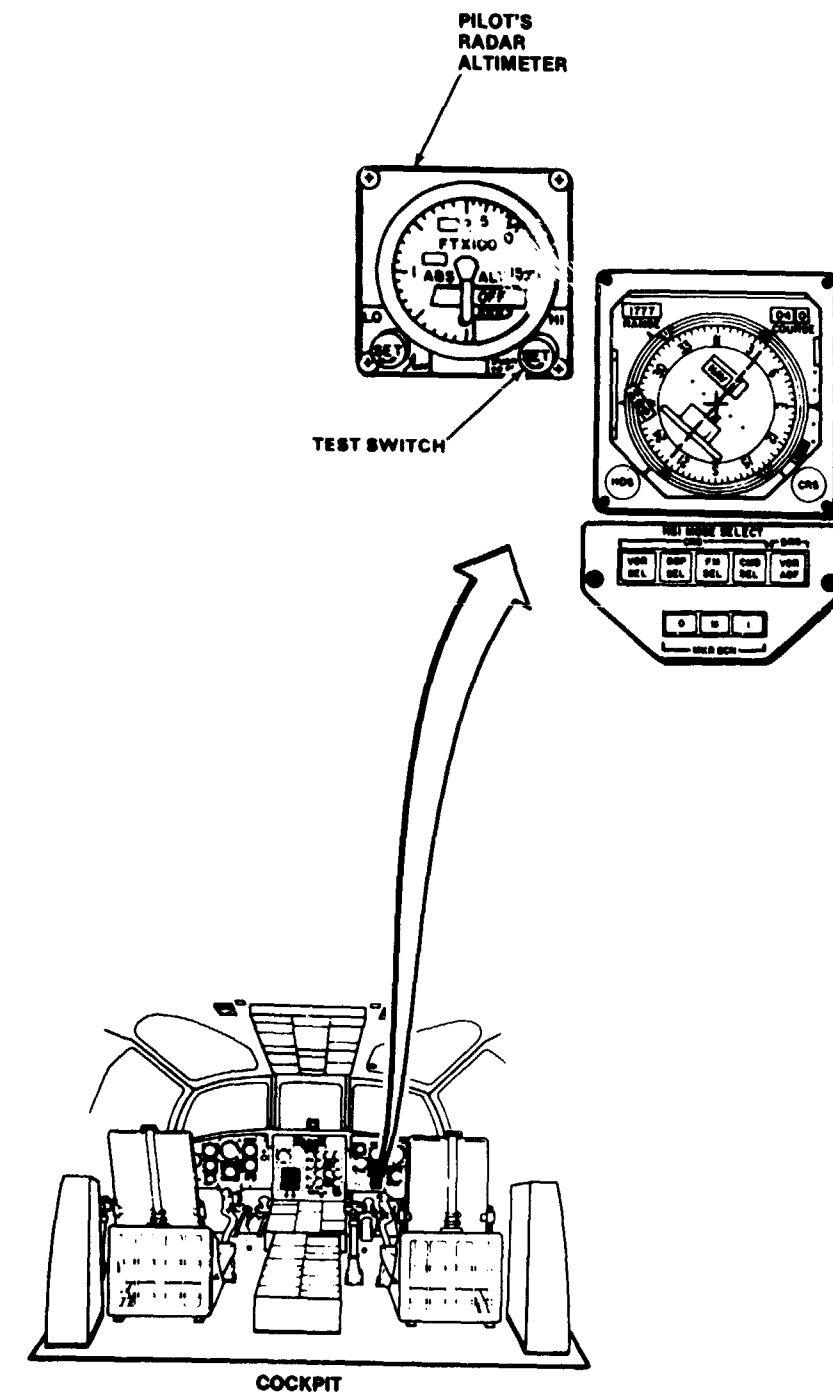
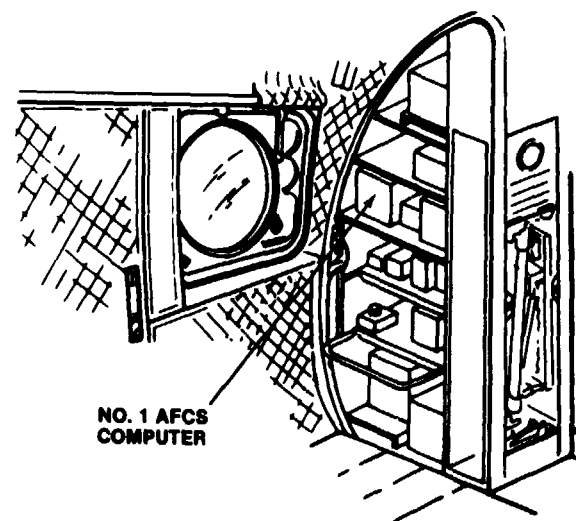

11-3.48 AFCS COMPUTER BITE INDICATES 95 (Continued)

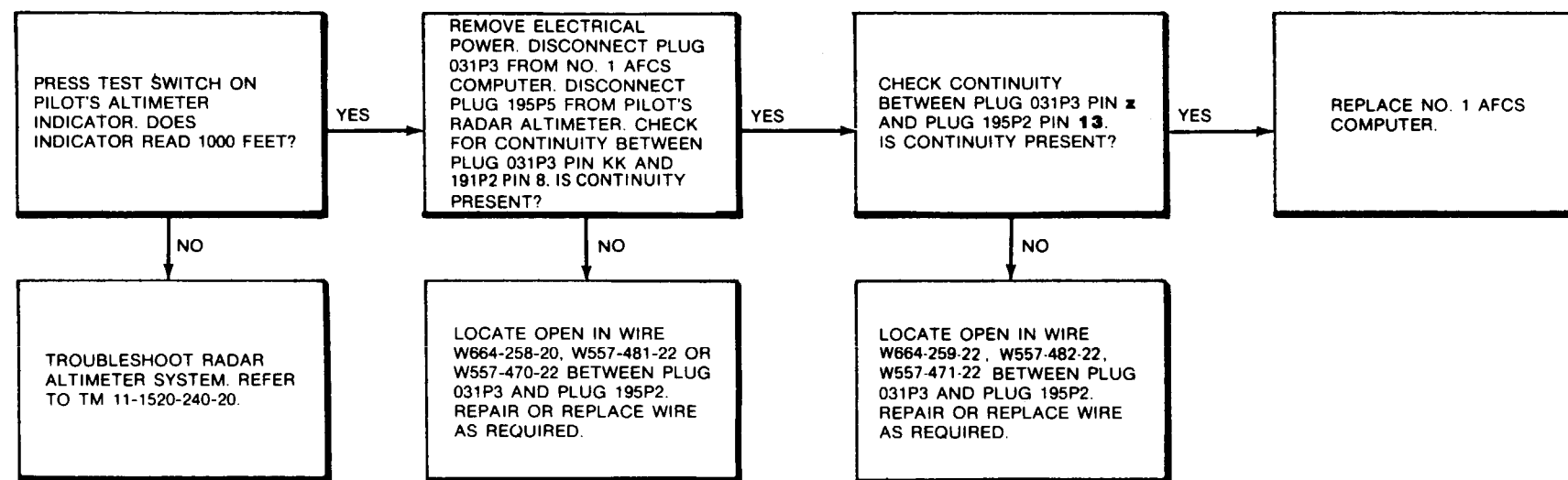

11-3.49 AFCS PITCH STABILIZATION ERRATIC OR OSCILLATORY

FAULT ISOLATION PROCEDURE

INITIAL SETUP

Applicable Configurations:

All

Tools:

Electrical Repairer's Tool Kit,
NSN 5180-00-323-4915

Multimeter

Materials:

None

Personnel Required:

35K10 Avionic Mechanic

35K20 Avionic Mechanic

References:

TM 55-1520-240-23

TM 55-4920-429-13

Equipment Condition:

TM 55-1520-240-23

Battery Connected

Electrical Power On

Hydraulic Power On

TM 55-4920-429-13

AFCS Line Test Set 145G0009-1

Prepared for Use

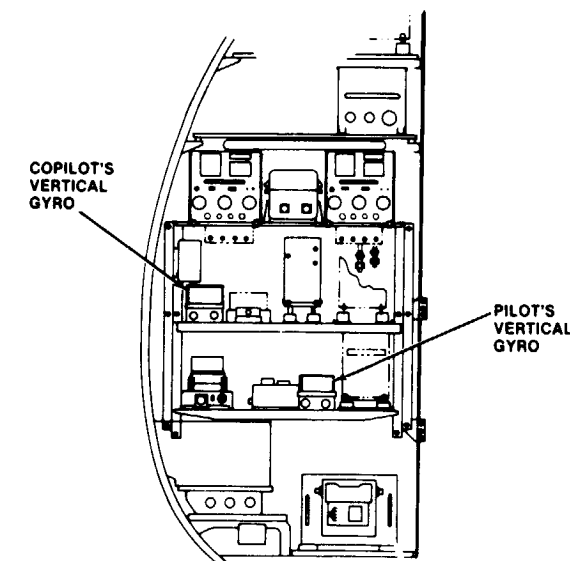
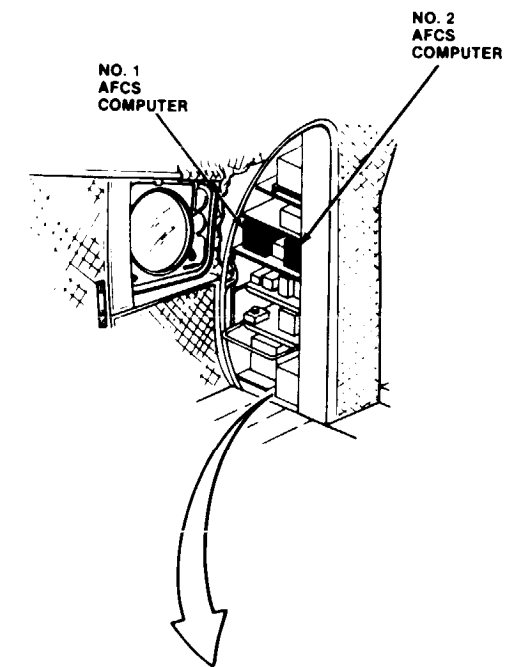

11-3.49 AFCS PITCH STABILIZATION ERRATIC OR OSCILLATORY
(Continued)

11-3.49

**NO. 1 AFCS PITCH STABILIZATION
ERRATIC OR OSCILLATORY**

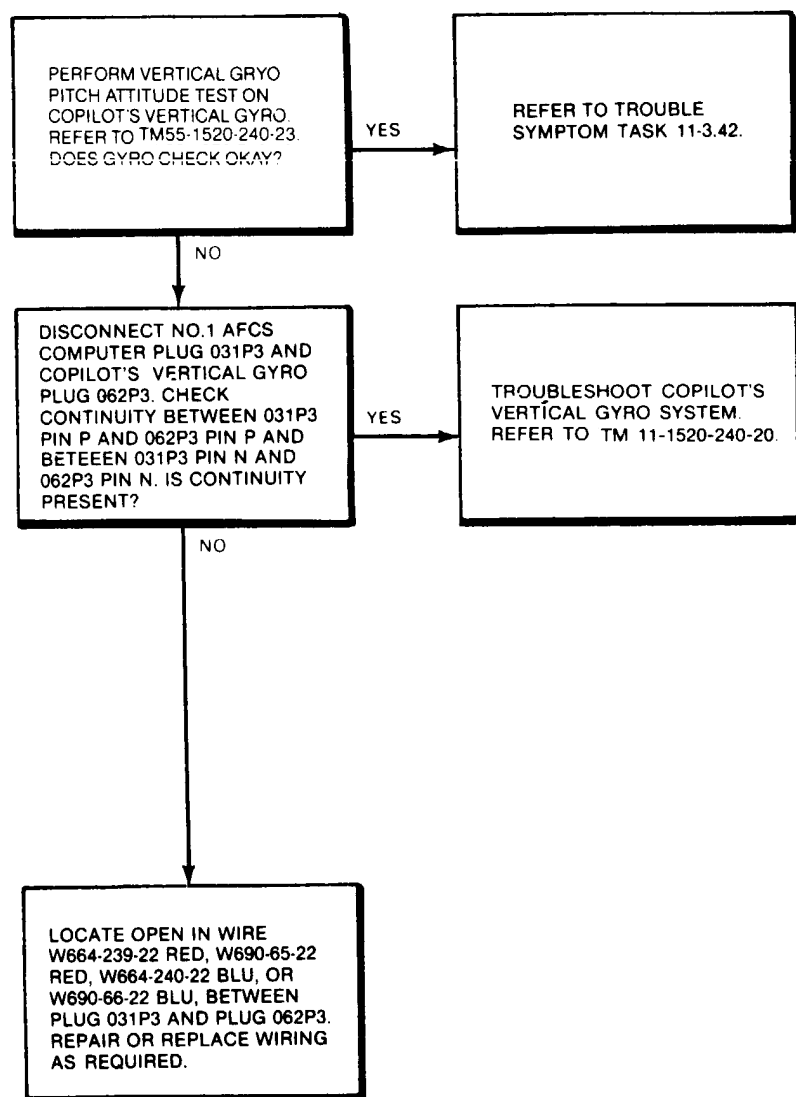

**NO. 2 AFCS PITCH STABILIZATION
ERRATIC OR OSCILLATORY**

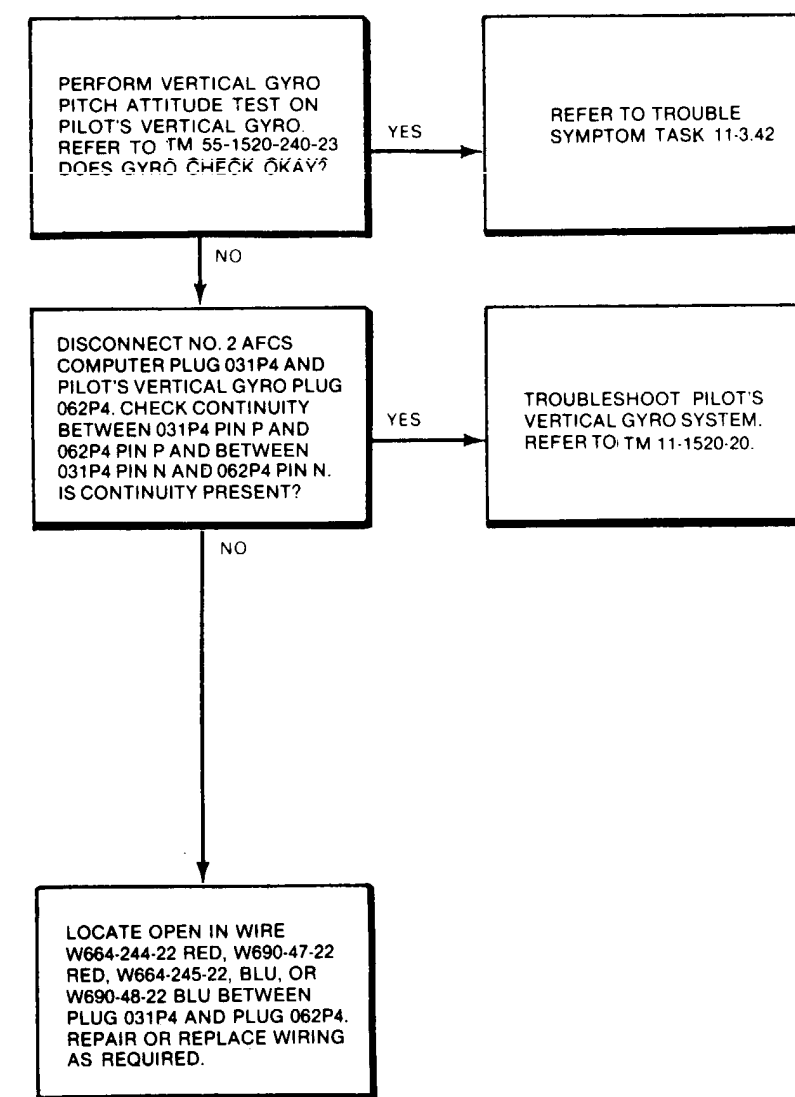

END OF TASK

11-3.50 NO. 1 AFCS PITCH ATTITUDE/AIR SPEED HOLD WEAK OR
INOPERATIVE

FAULT ISOLATION PROCEDURE

INITIAL SETUP

Applicable Configurations:

All

Tools:

Electrical Repairer's Tool Kit,
NSN 5180-00-323-4915
Multimeter

Materials:

None

Personnel Required:

35K10 Avionic Mechanic
35K20 Avionic Mechanic

References:

TM 55-1520-240-23
TM 55-4920-429-13

Equipment Condition:

TM 55-1520-240-23
Battery Connected
Electrical Power On
Hydraulic Power On
TM 55-4920-429-13
AFCS Line Test Set 145G0009-1
Prepared For Use

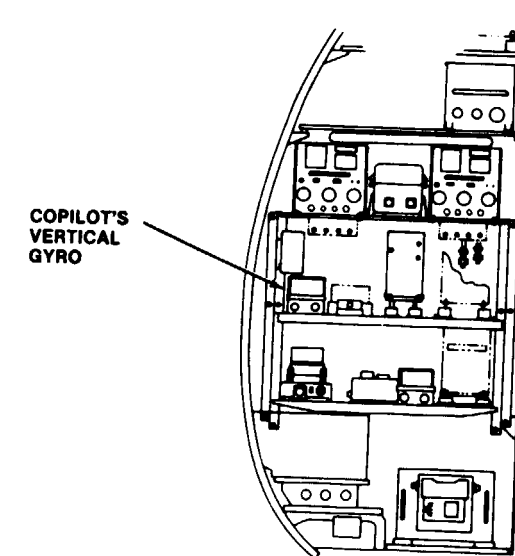
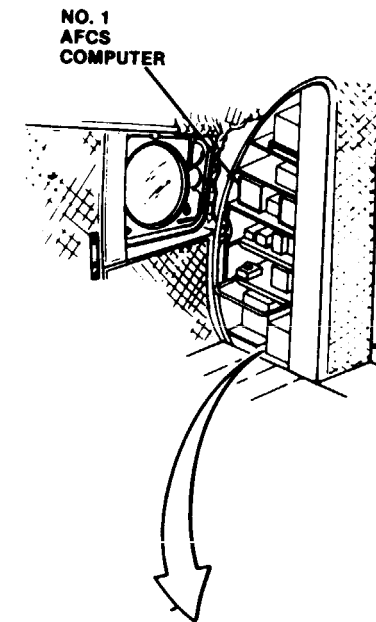

45X64

D145-1945-SPA

GO TO NEXT PAGE

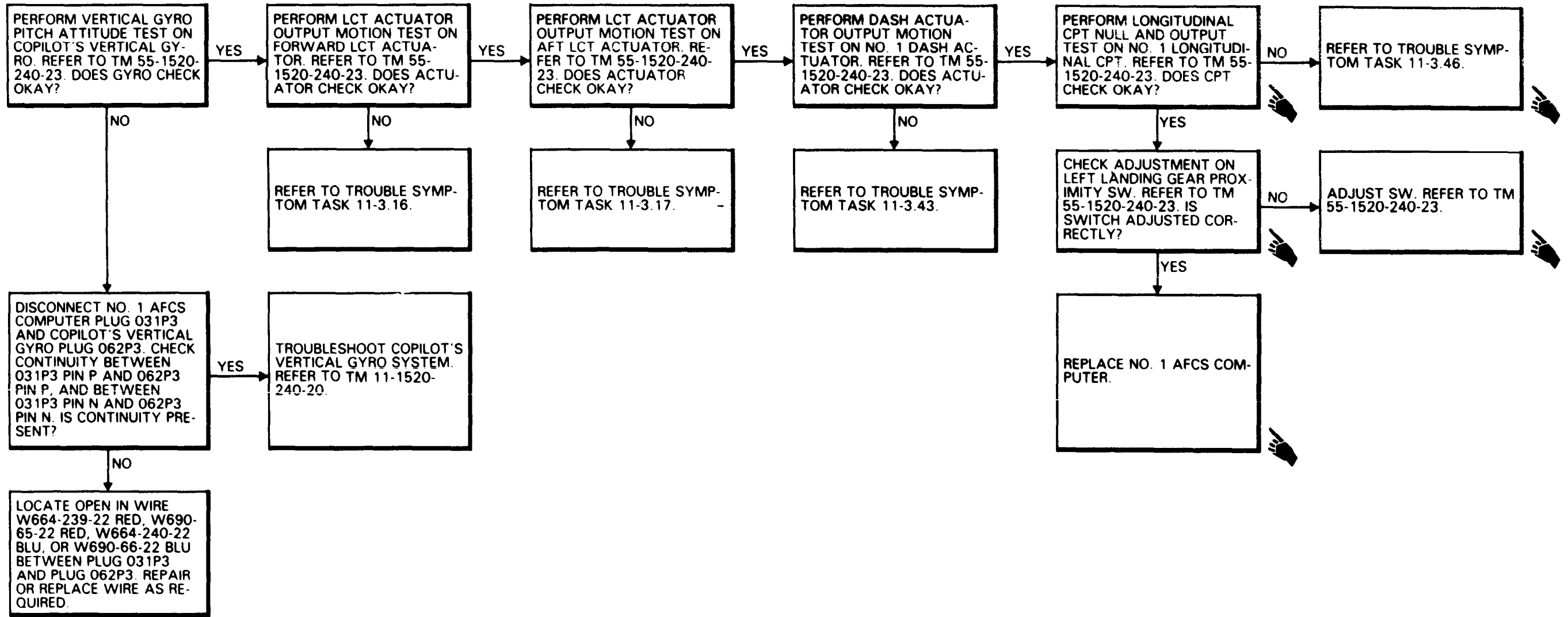

11-3.51 NO. 2 AFCS PITCH ATTITUDE/AIR SPEED HOLD WEAK OR
INOPERATIVE

FAULT ISOLATION PROCEDURE

INITIAL SETUP

Applicable Configurations:

All

Tools:

Electrical Repairer's Tool Kit,
NSN 5180-00-323-4915
Multimeter

Materials:

None

Personnel Required:

35K10 Avionic Mechanic
35K20 Avionic Mechanic

References:

TM 55-1520-240-23
TM 55-4920-429-13

Equipment Condition:

TM 55-1520-240-23
Battery Connected
Electrical Power On
Hydraulic Power On
TM 55-4920-429-13
AFCS Line Test Set 145G0009-1
Prepared For Use

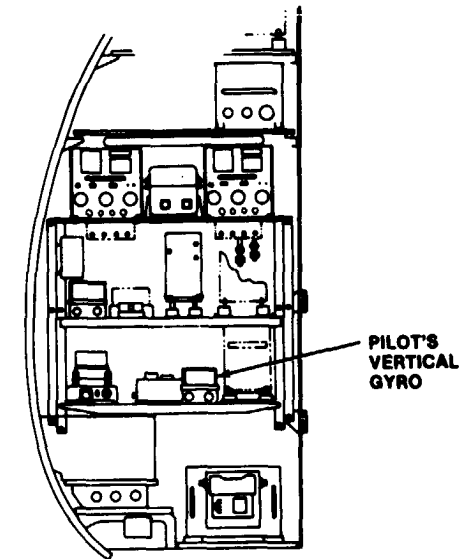
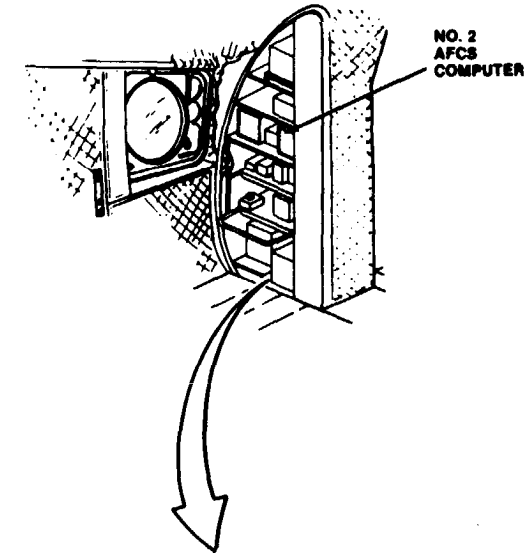

11-3.51 NO. 2 AFCS PITCH ATTITUDE/AIR SPEED HOLD WEAK OR INOPERATIVE (Continued)

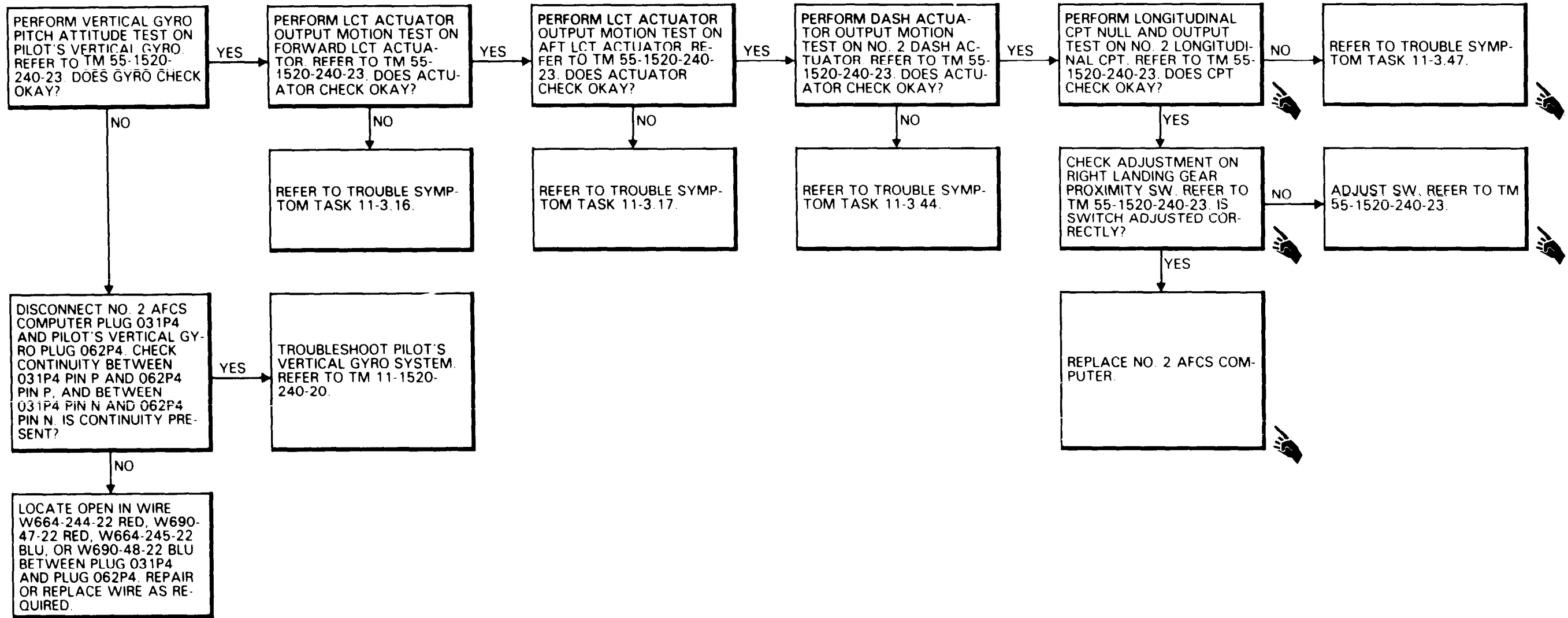

11-3.52 AFCS LONGITUDINAL CONTROL POSITION OUT OF TRIM

FAULT ISOLATION PROCEDURE

INITIAL SETUP

Applicable Configurations:

All

Tools:

Electrical Repairer's Tool Kit,
NSN 5180-00-323-4915
Multimeter

Materials:

None

Personnel Required:

35K10 Avionic Mechanic
35K20 Avionic Mechanic

References:

TM 55-1520-240-23
TM 55-4920-429-13

Equipment Condition:

TM 55-1520-240-23
Battery Connected
Electrical Power On
Hydraulic Power On
TM 55-4920-429-13
AFCS Line Test Set 145G0009-1
Prepared For Use

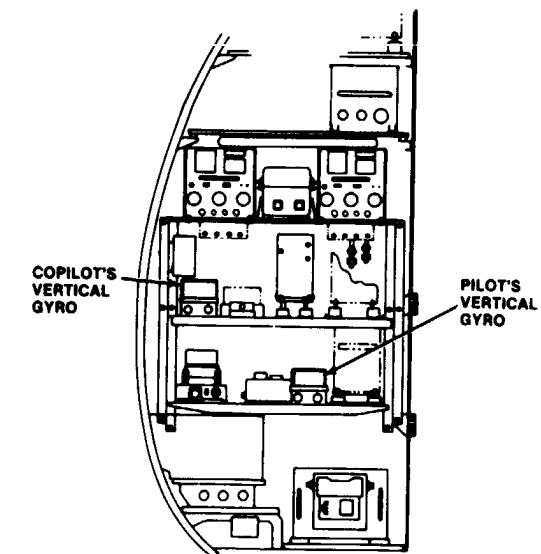
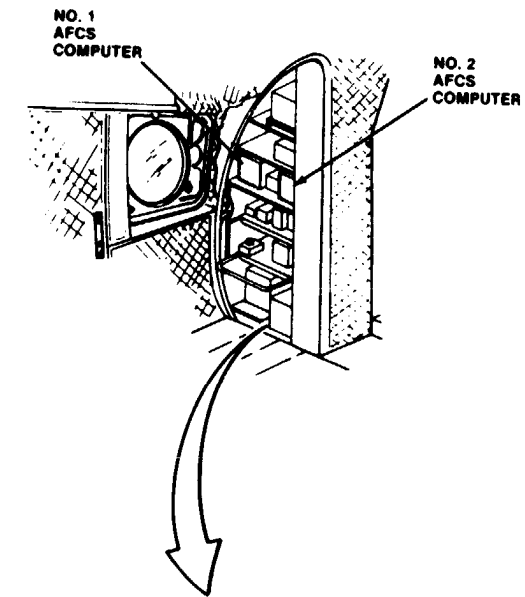

45X64

D145-11847-SPA

GO TO NEXT PAGE

11-3.52 AFCS LONGITUDINAL CONTROL POSITION OUT OF TRIM
(Continued)

11-3.52

NO. 1 AFCS LONGITUDINAL CONTROL POSITION OUT OF TRIM

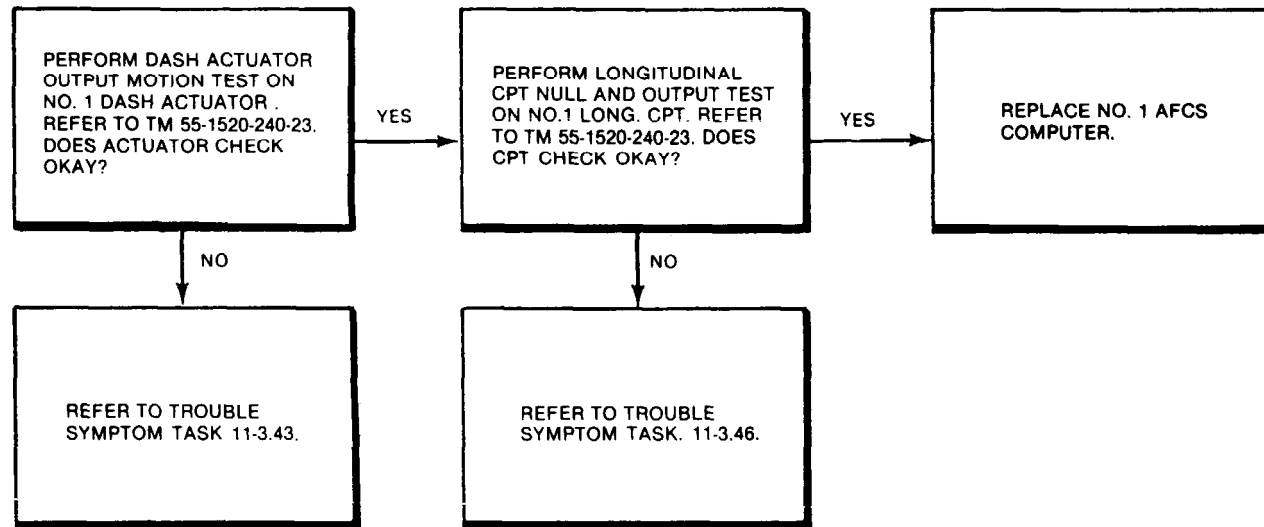

NO. 2 AFCS LONGITUDINAL CONTROL POSITION OUT OF TRIM

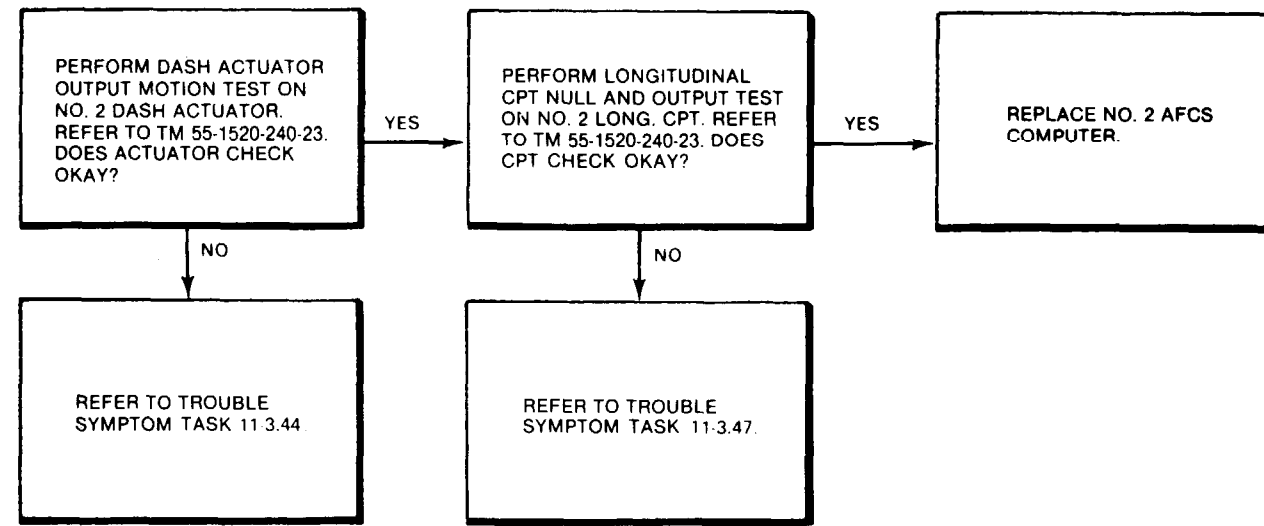

END OF TASK

11-3.53 AFCS ROLL STABILIZATION ERRATIC/OSCILLATORY OR ROLL ATTITUDE HOLD WEAK OR INOPERATIVE

FAULT ISOLATION PROCEDURE

INITIAL SETUP

Applicable Configurations:

All

Tools:

- Electrical Repairer's Tool Kit,
NSN 5180-00-323-4915
- Multimeter

Materials:

None

Personnel Required:

- 35K10 Avionic Mechanic
- 35K20 Avionic Mechanic

References:

- TM 55-1520-240-23
- TM 55-4920-429-13

Equipment Condition:

- TM 55-1520-249-23
- Battery Connected
- Electrical Power On
- Hydraulic Power On
- TM 55-4920-429-13
- AFCS Line Test Set 145G0009-1
- Prepared For Use

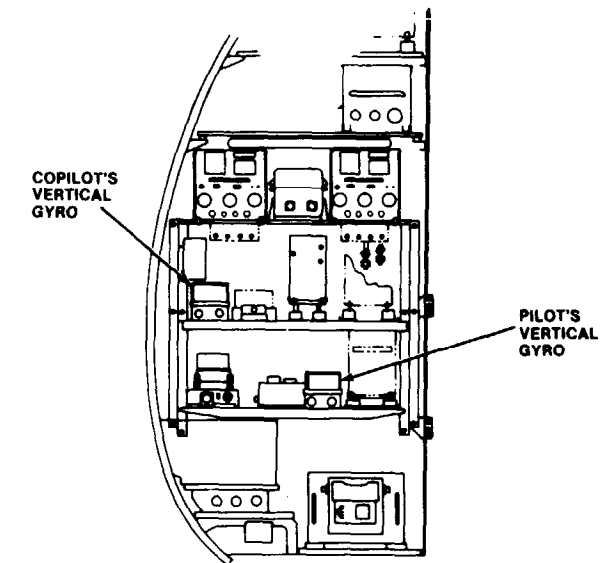
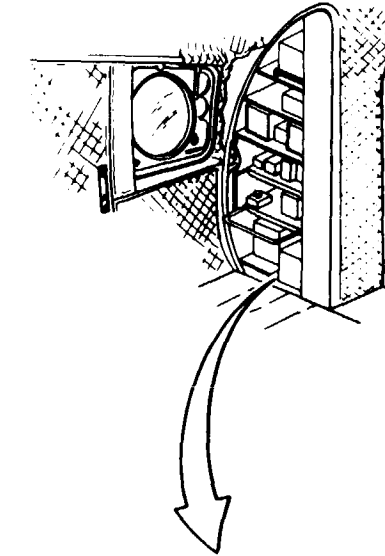

11-3.53 AFCS ROLL STABILIZATION ERRATIC/OSCILLATORY OR ROLL ATTITUDE HOLD WEAK OR INOPERATIVE (Continued)

NO. 1 AFCS ROLL STABILIZATION ERRATIC/OSCILLATORY OR ROLL ATTITUDE HOLD WEAK OR INOPERATIVE

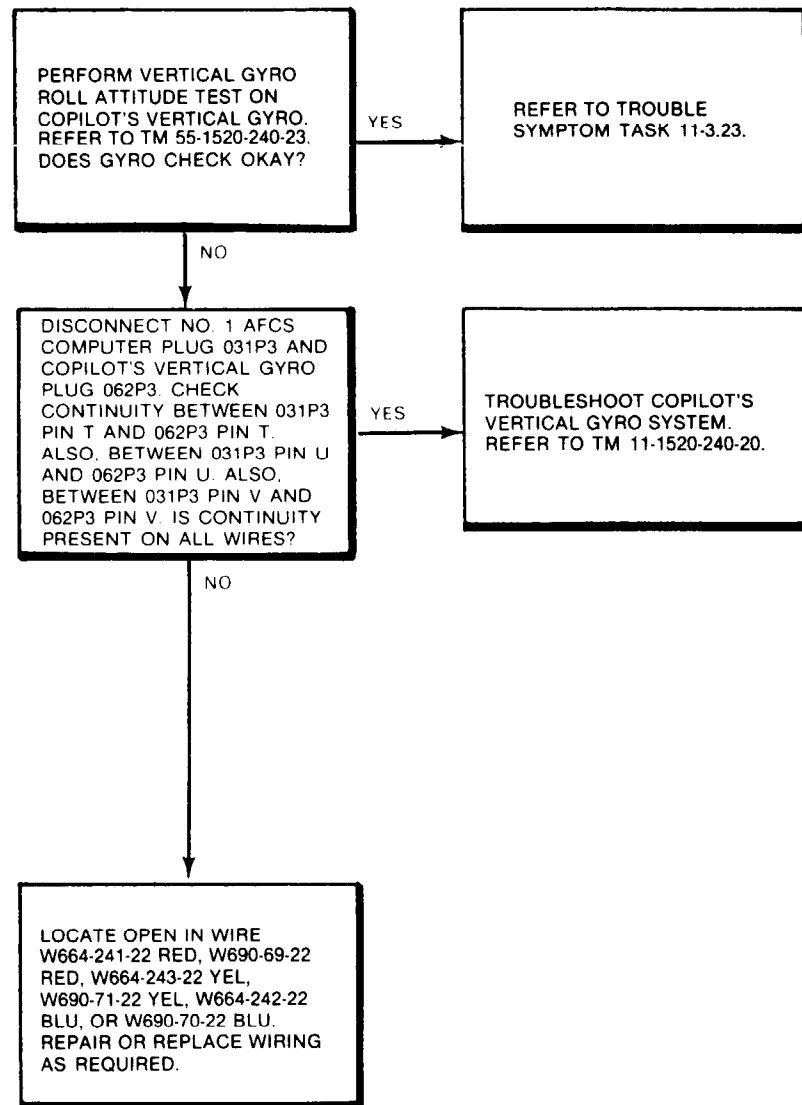

NO. 2 AFCS ROLL STABILIZATION ERRATIC/OSCILLATORY OR ROLL ATTITUDE HOLD WEAK OR INOPERATIVE

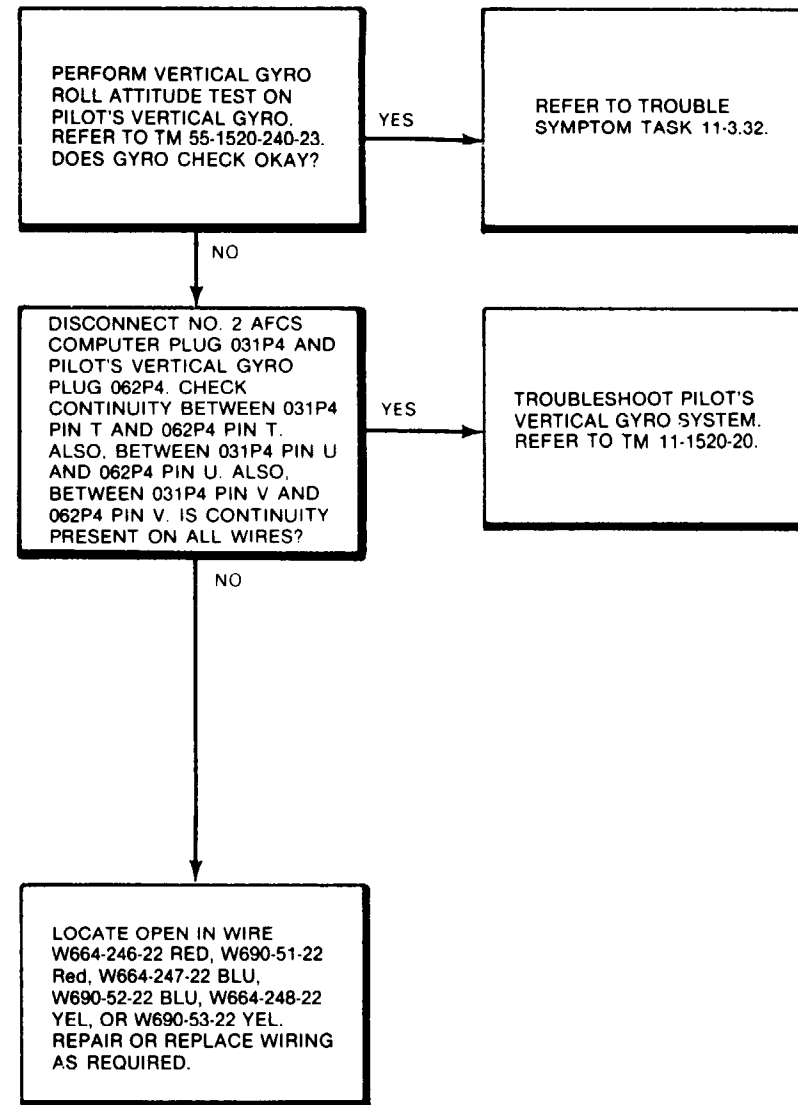

END OF TASK

11-3.54 HEADING SELECT MODE RESPONSE WEAK OR INOPERATIVE
(BOTH SYSTEMS)

FAULT ISOLATION PROCEDURE

INITIAL SETUP

Applicable Configurations:

All

Personnel Required:

- 35K10 Avionic Mechanic
- 35K20 Avionic Mechanic

Tools:

- Electrical Repairer's Tool Kit,
NSN 5180-00-323-4915
- Multimeter

References:

- TM 55-1520-240-23
- TM 55-4920-429-13

Materials:

None

Equipment Condition:

- TM 55-1520-240-23
- Battery Connected
- Electrical Power On
- Hydraulic Power On
- TM 55-4920-429-13
- AFCS Line Test Set 145G0009-1
- Prepared for Use

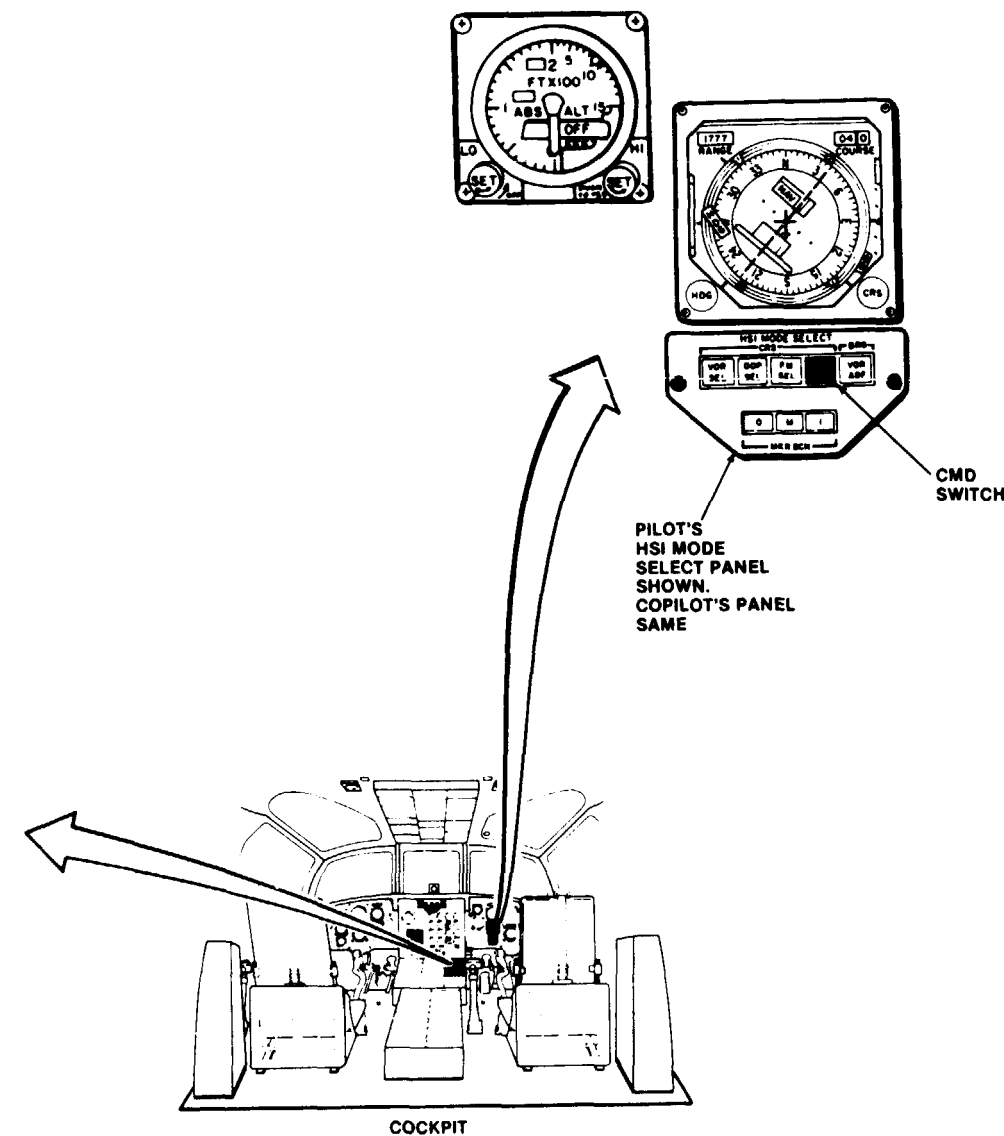
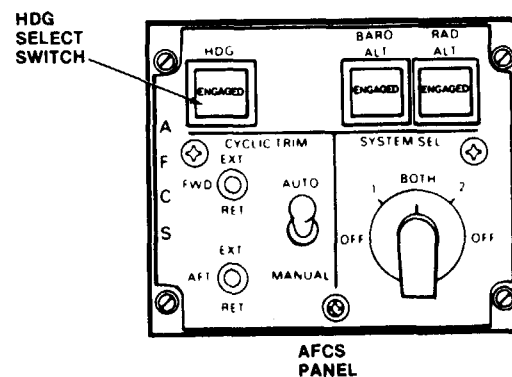
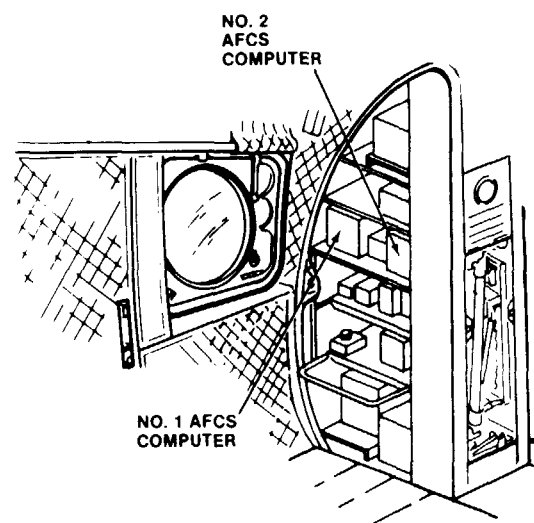

11-3.54 HEADING SELECT MODE RESPONSE WEAK OR INOPERATIVE (BOTH SYSTEMS) (Continued)

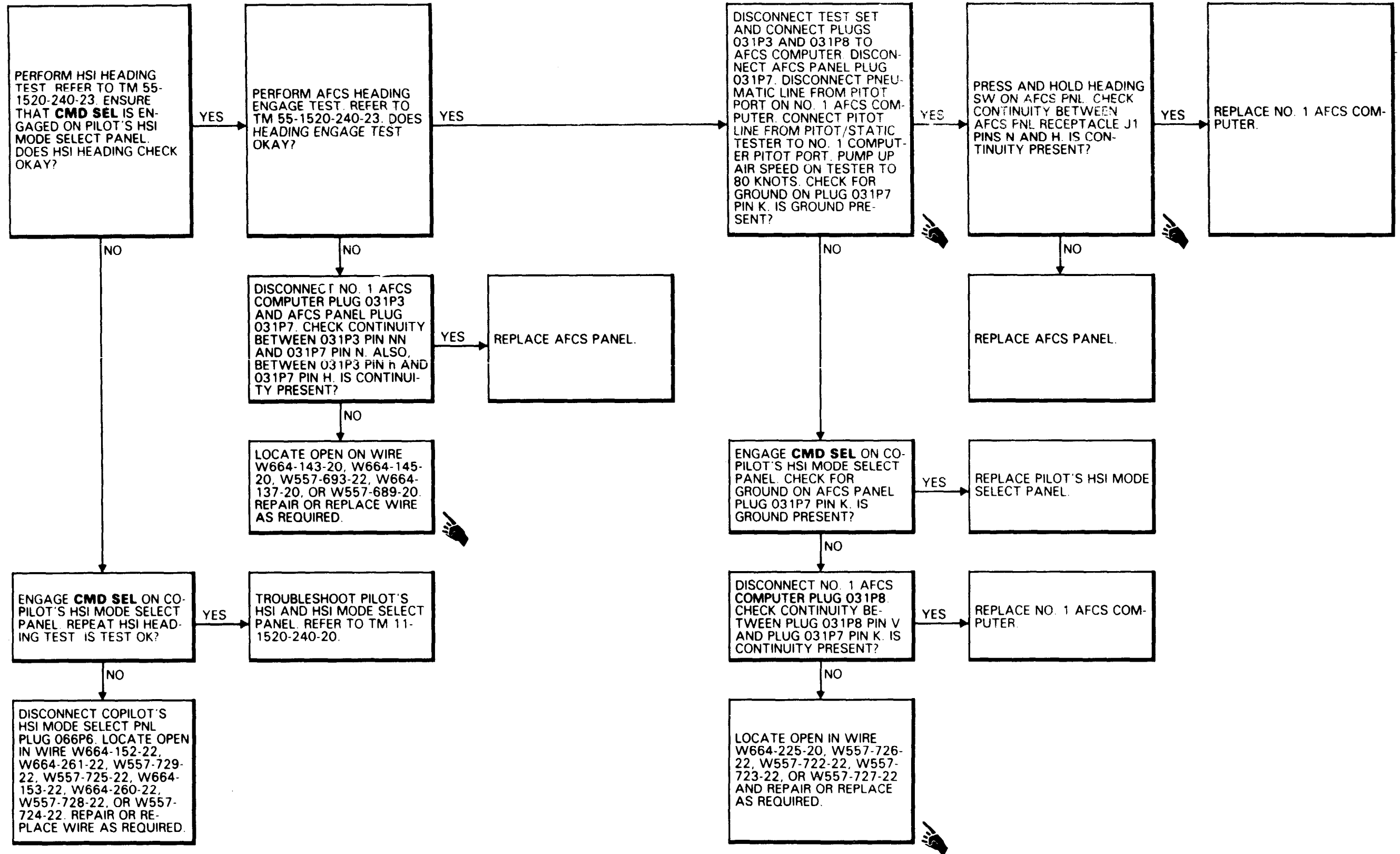

11-3.55 NO. 1 AFCS HEADING SELECT MODE RESPONSE WEAK OR INOPERATIVE

FAULT ISOLATION PROCEDURE

INITIAL SETUP

Applicable Configurations:
All

Personnel Required:
35K10 Avionic Mechanic
35K20 Avionic Mechanic

Tools:
Electrical Repairer's Tool Kit,
NSN 5180-00-323-4915
Multimeter

References:
TM 55-1520-240-23
TM 55-4920-429-13

Materials:
None

Equipment Condition:
TM 55-1520-240-23
Battery Connected
Electrical Power On
Hydraulic Power On
TM 55-4920-429-13
AFCS Line Test Set 146G0009-1
Prepared For Use

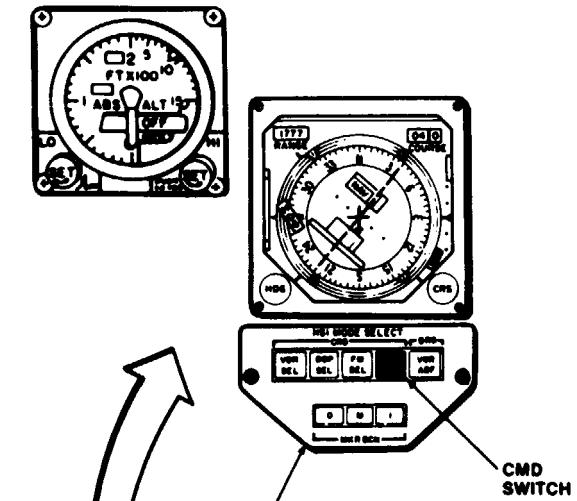
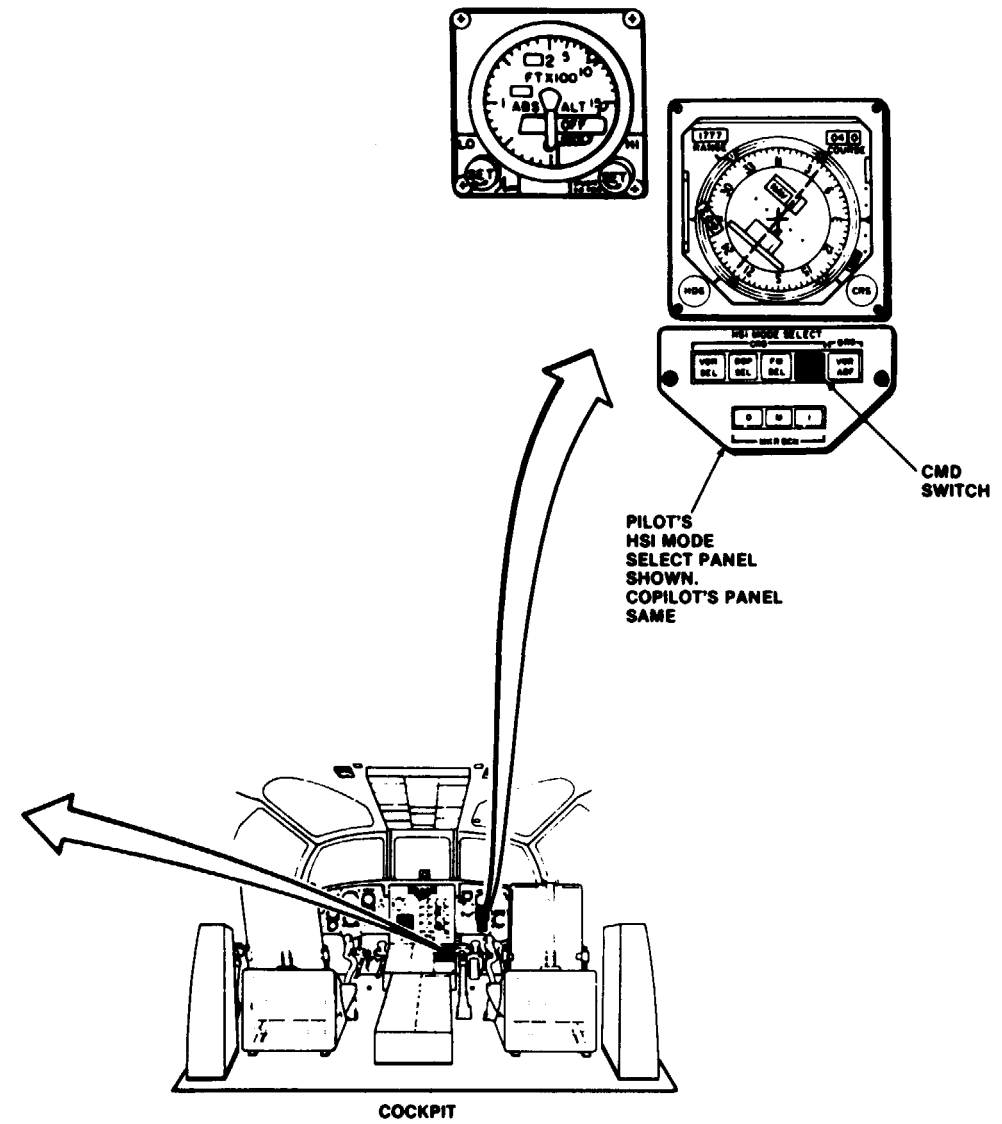
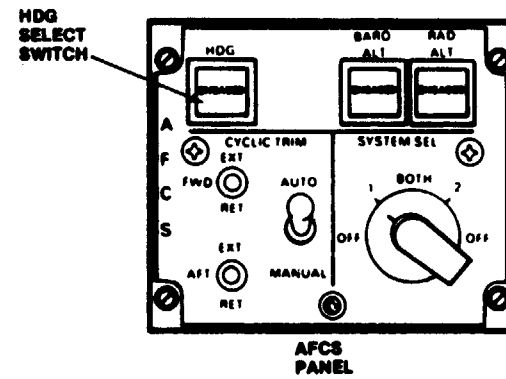
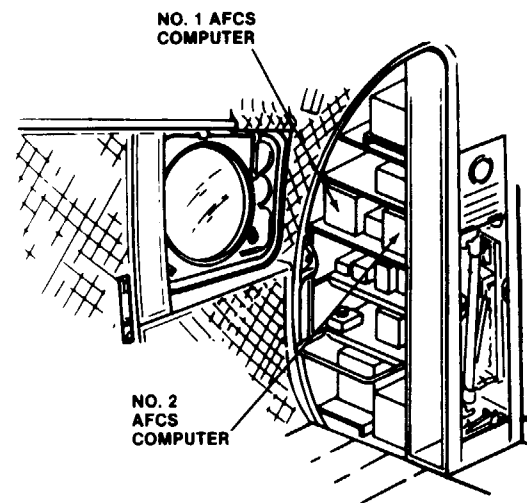

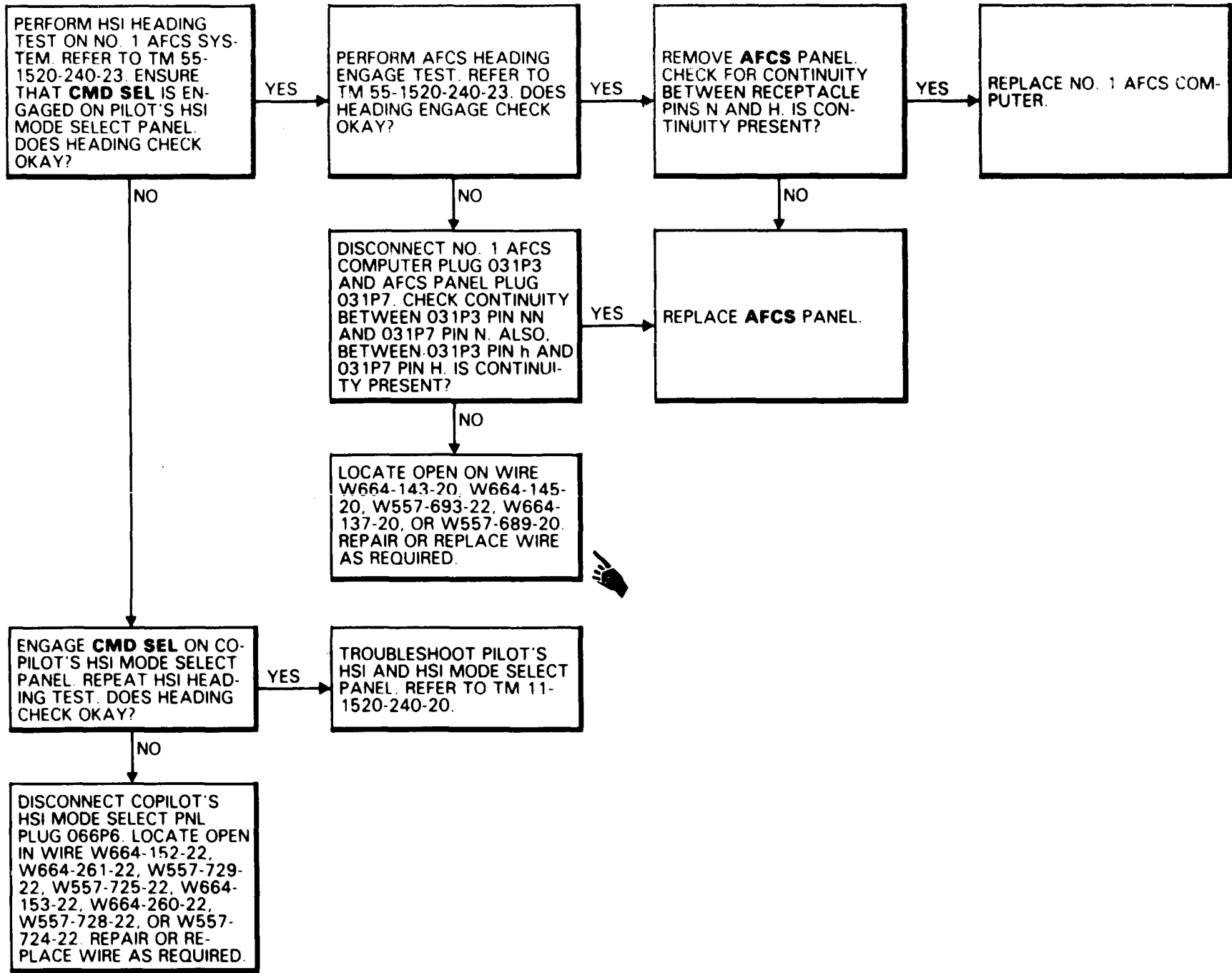

FAULT ISOLATION PROCEDURE

INITIAL SETUP

Applicable Configurations:
All

Personnel Required:
35K10 Avionic Mechanic
35K20 Avionic Mechanic

Tools:
Electrical Repairer's Tool Kit,
NSN 5180-00-323-4915
Multimeter

References:
TM 55-1520-240-23
TM 55-4920-429-13

Materials:
None

Equipment Condition:
TM 55-1520-240-23
Battery Connected
Electrical Power On
Hydraulic Power On
TM 55-4920-420-13
AFCS Line Test Set 145G0009-1
Prepared For Use

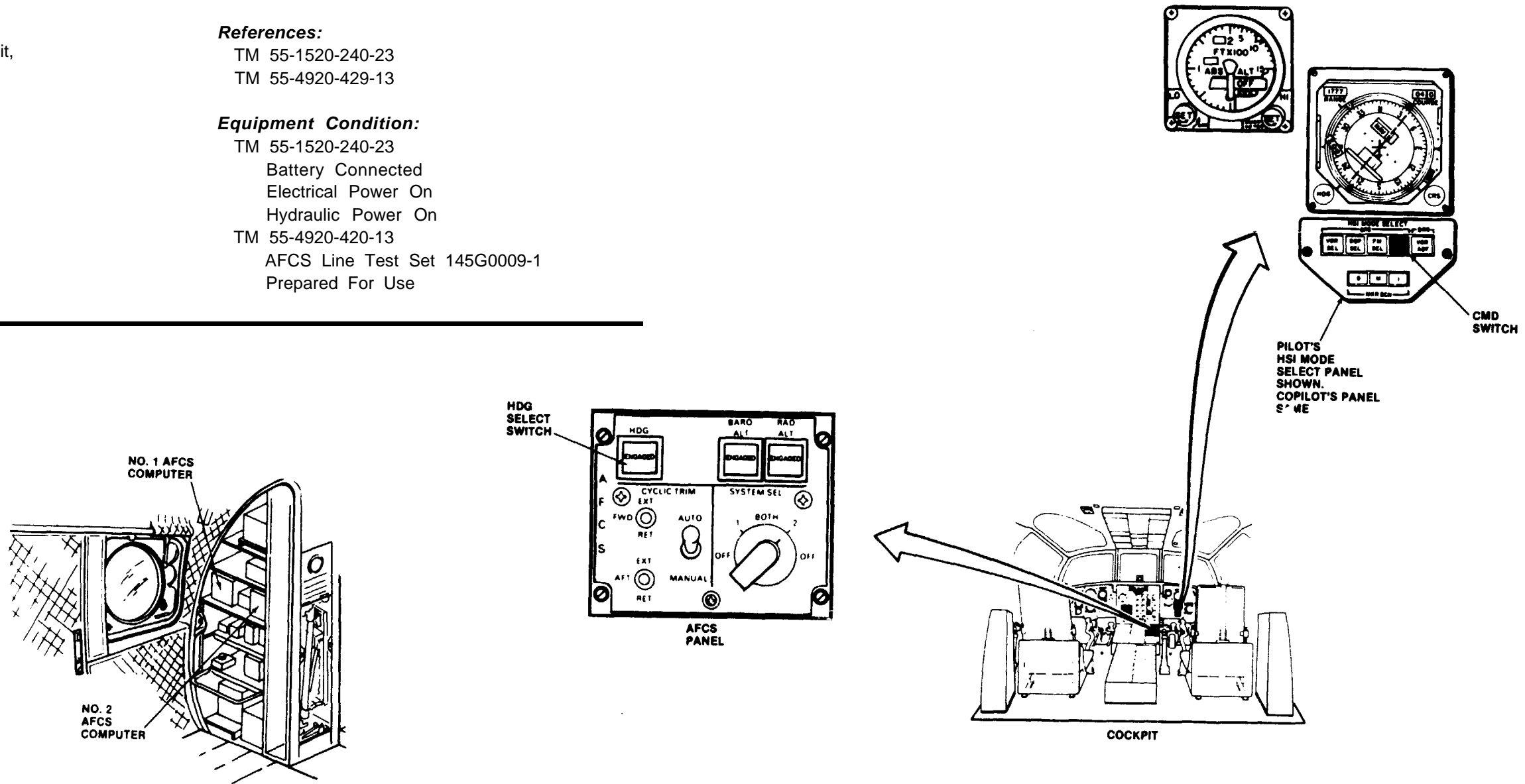

11-3.56 NO. 2 AFCS HEADING SELECT MODE RESPONSE WEAK OR INOPERATIVE (Continued)

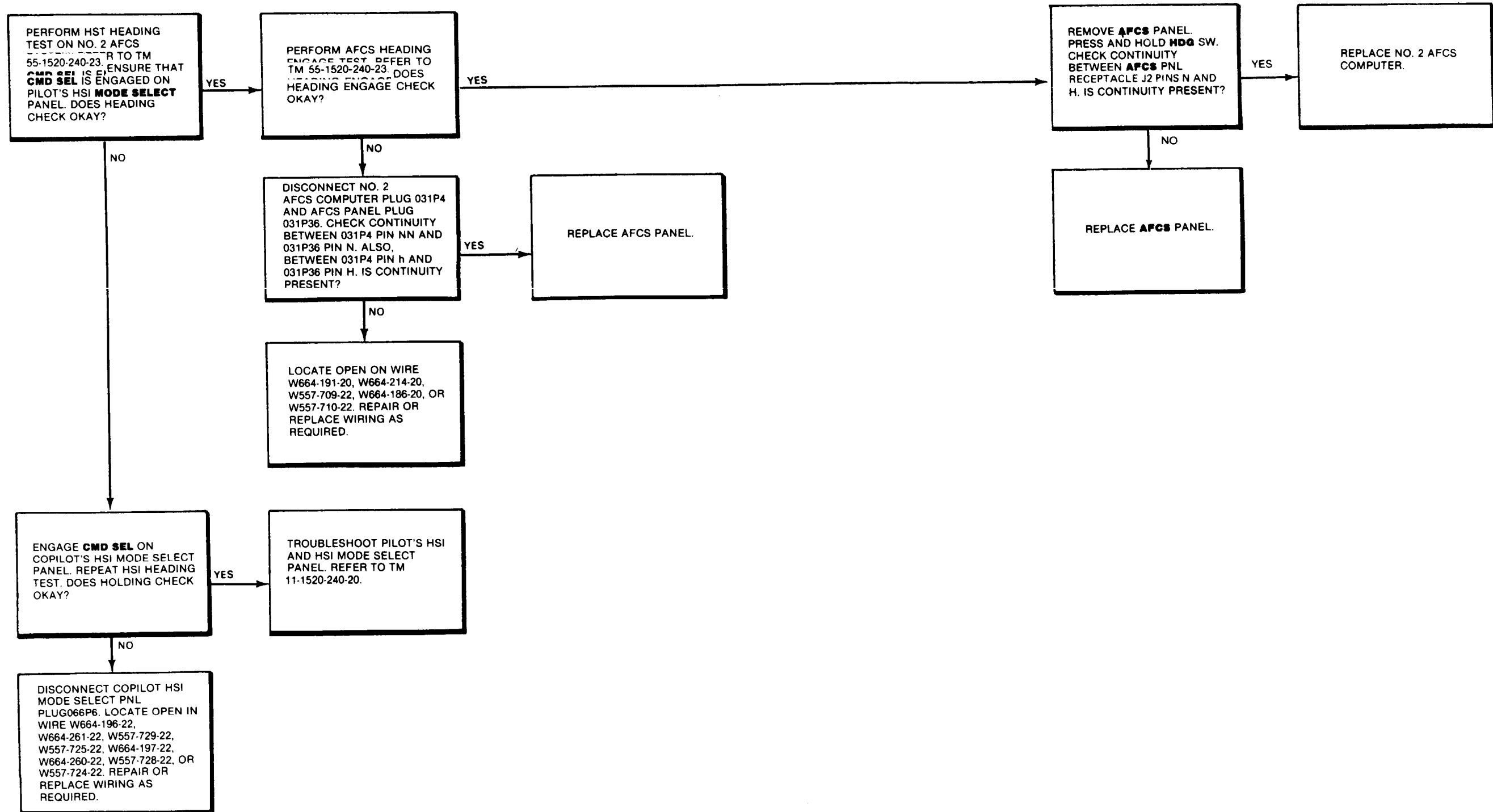

END OF TASK

11-3.57 NO. 1 AFCS YAW STABILITY ERRATIC/OSCILLATORY

FAULT ISOLATION PROCEDURE

INITIAL SETUP

Applicable Configurations:

All

Tools:

- Electrical Repairer's Tool Kit,
NSN 5180-00-323-4915
- Multimeter

Materials:

None

Personnel Required:

Avionic Mechanic (2)

References:

- TM 55-1520-240-23
- TM 55-4920-429-13

Equipment Condition:

- TM 55-1520-240-23:
Battery Connected
Electrical Power On
Hydraulic Power On
- TM 55-4920-429-13:
AFCS Line Test Set 145G0009-1 Prepared
for Use

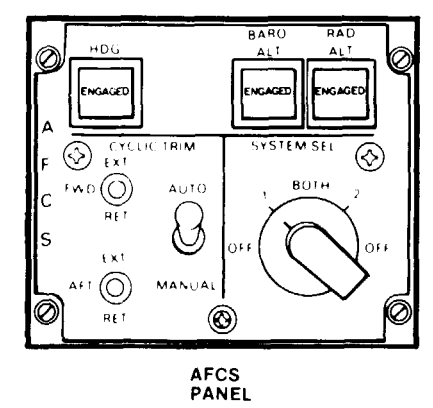
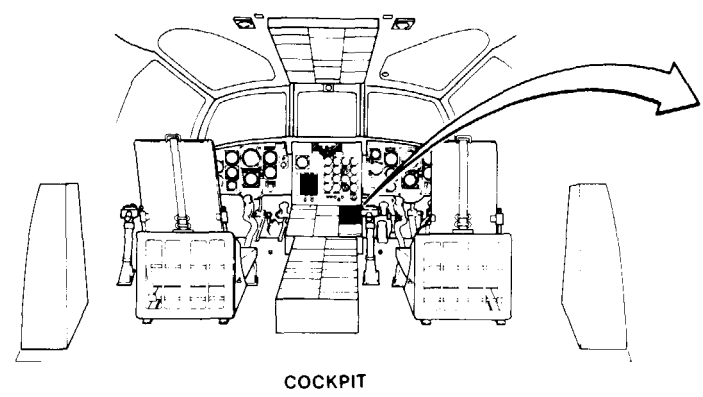
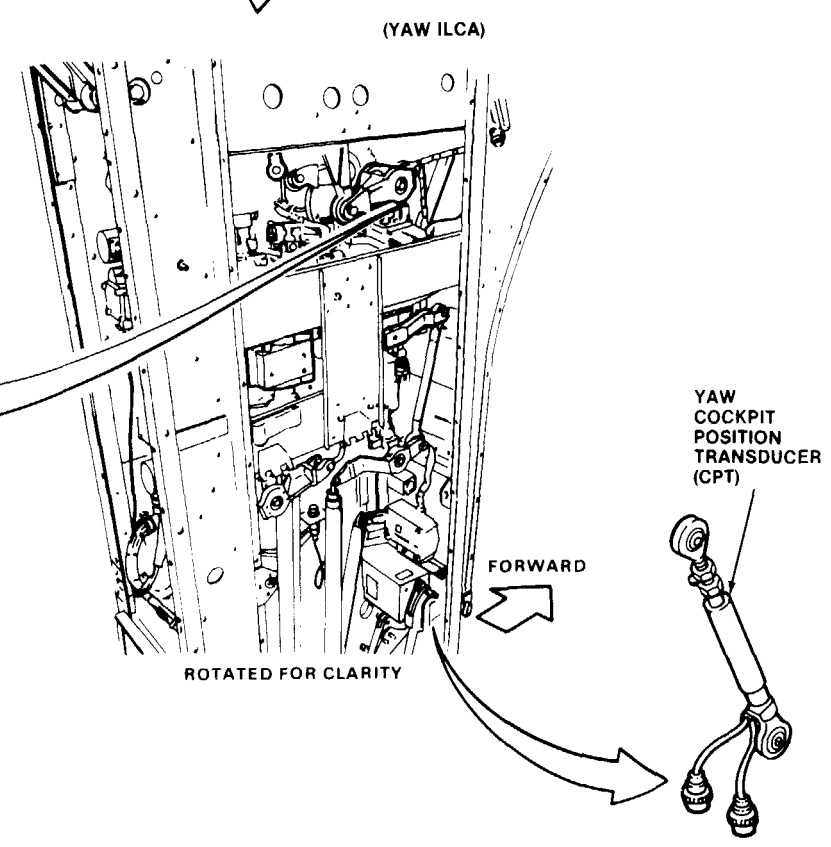
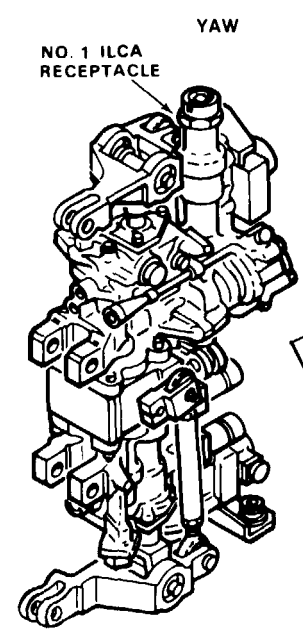
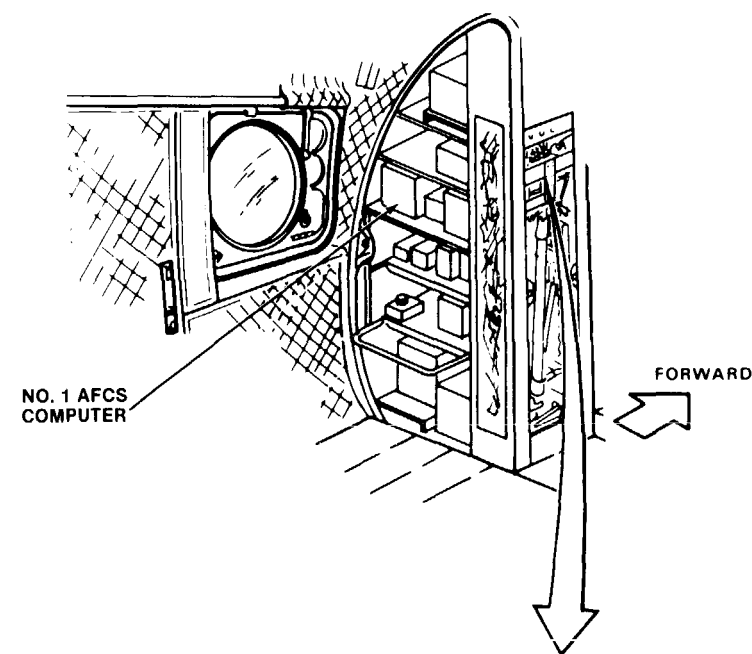

90 x 54

D145-11961-SPA

GO TO NEXT PAGE

11-3.57 NO. 1 AFCS YAW STABILITY ERRATIC/OSCILLATORY
(Continued)

11-3.57

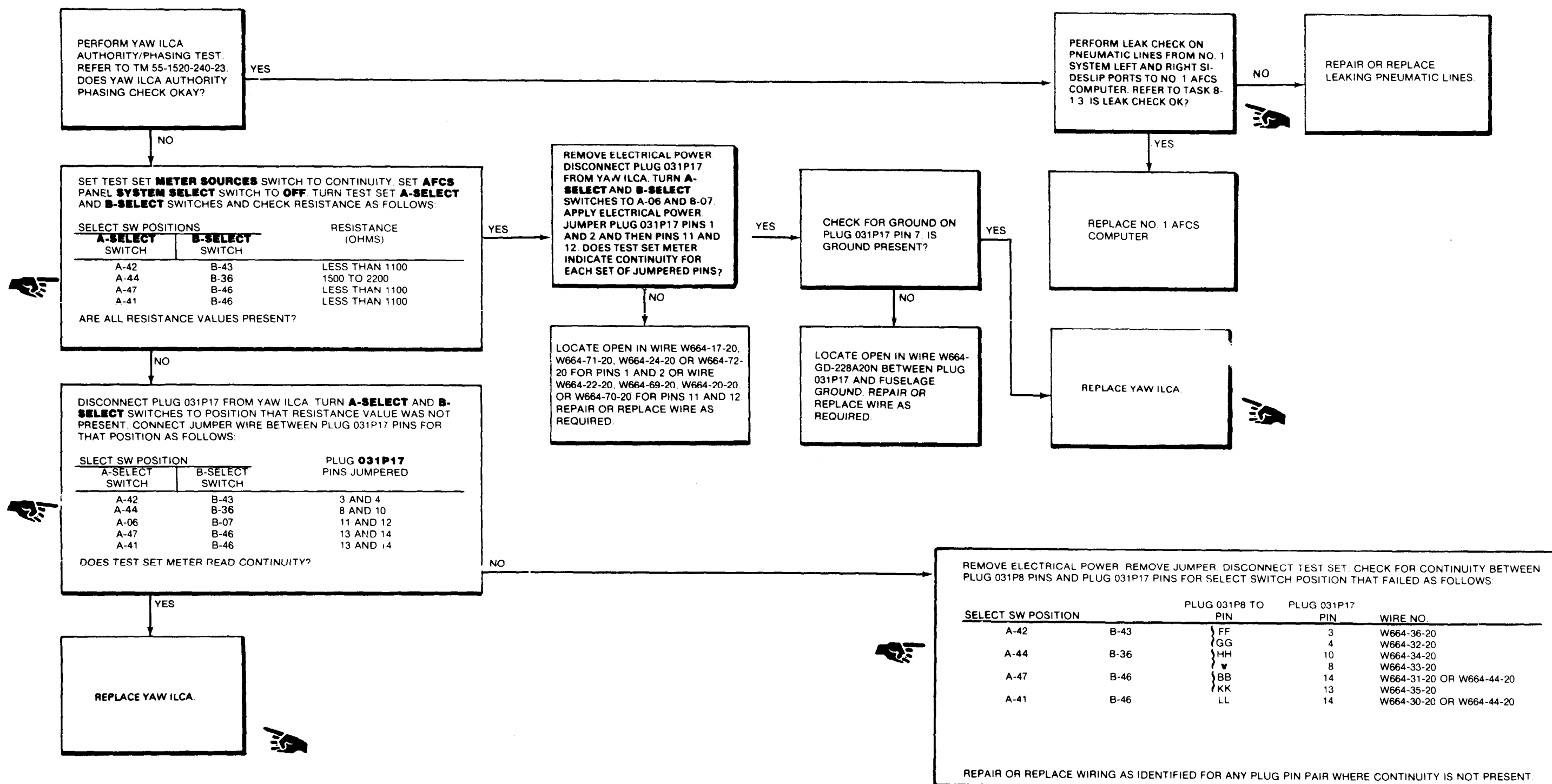

END OF TASK

11-3.58 NO. 2 AFCS YAW STABILITY ERRATIC/OSCILLATORY

FAULT ISOLATION PROCEDURE

INITIAL SETUP

Applicable Configurations:

All

Tools:

Electrical Repairer's Tool Kit,
NSN 5180-00-323-4915
Multimeter

Materials:

None

Personnel Required:

35K10 Avionic Mechanic
35K20 Avionic Mechanic

References:

TM 55-1520-240-23
TM 55-4920-429-13

Equipment Condition:

TM 55-1520-240-23
Battery Connected
Electrical Power On
Hydraulic Power On
TM 55-4920-429-13
AFCS Line Test Set 145G0009-1
Prepared For Use

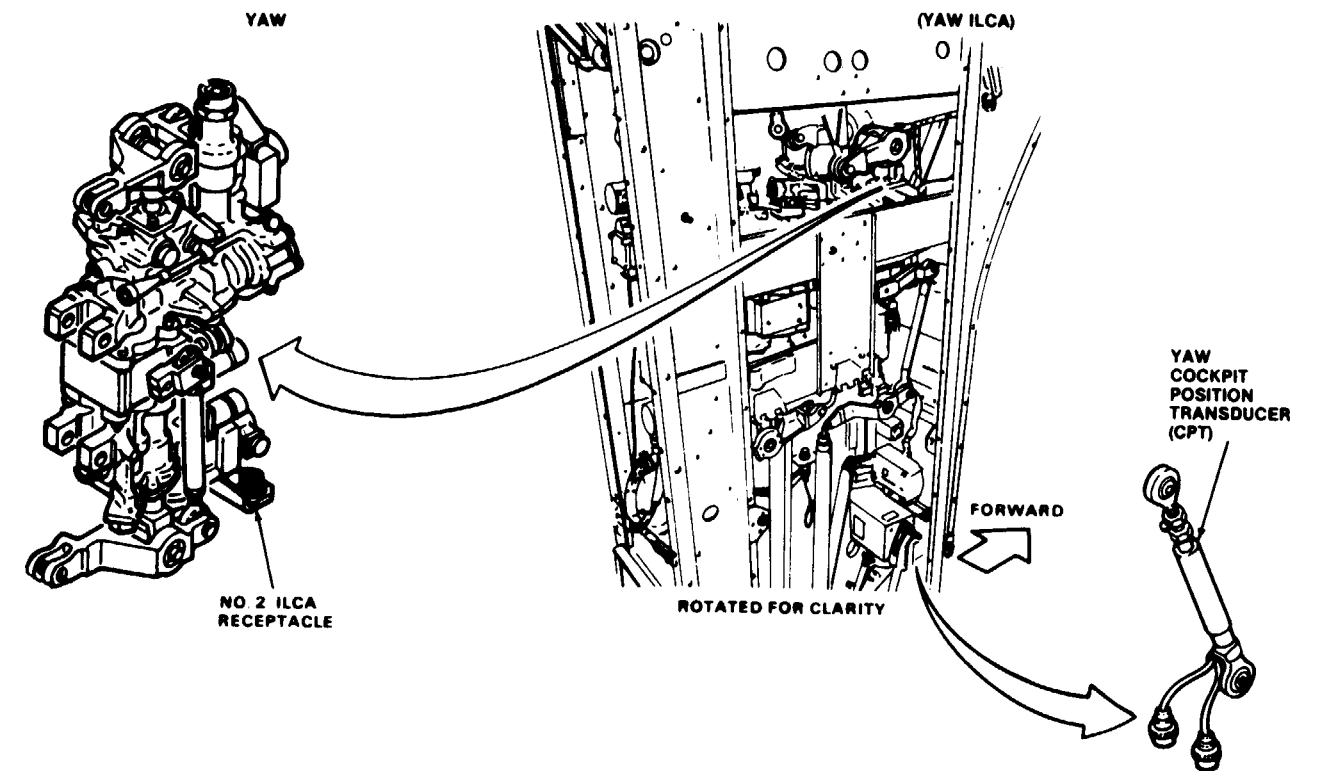
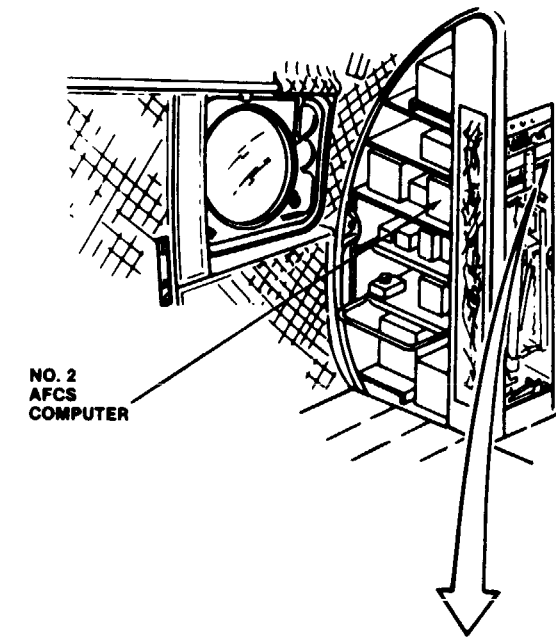

46 X 84

D145-11962-SPA

GO TO NEXT PAGE

11-3.58 NO. 2 AFCS YAW STABILITY ERRATIC/OSCILLATORY
(Continued)

11-3.58

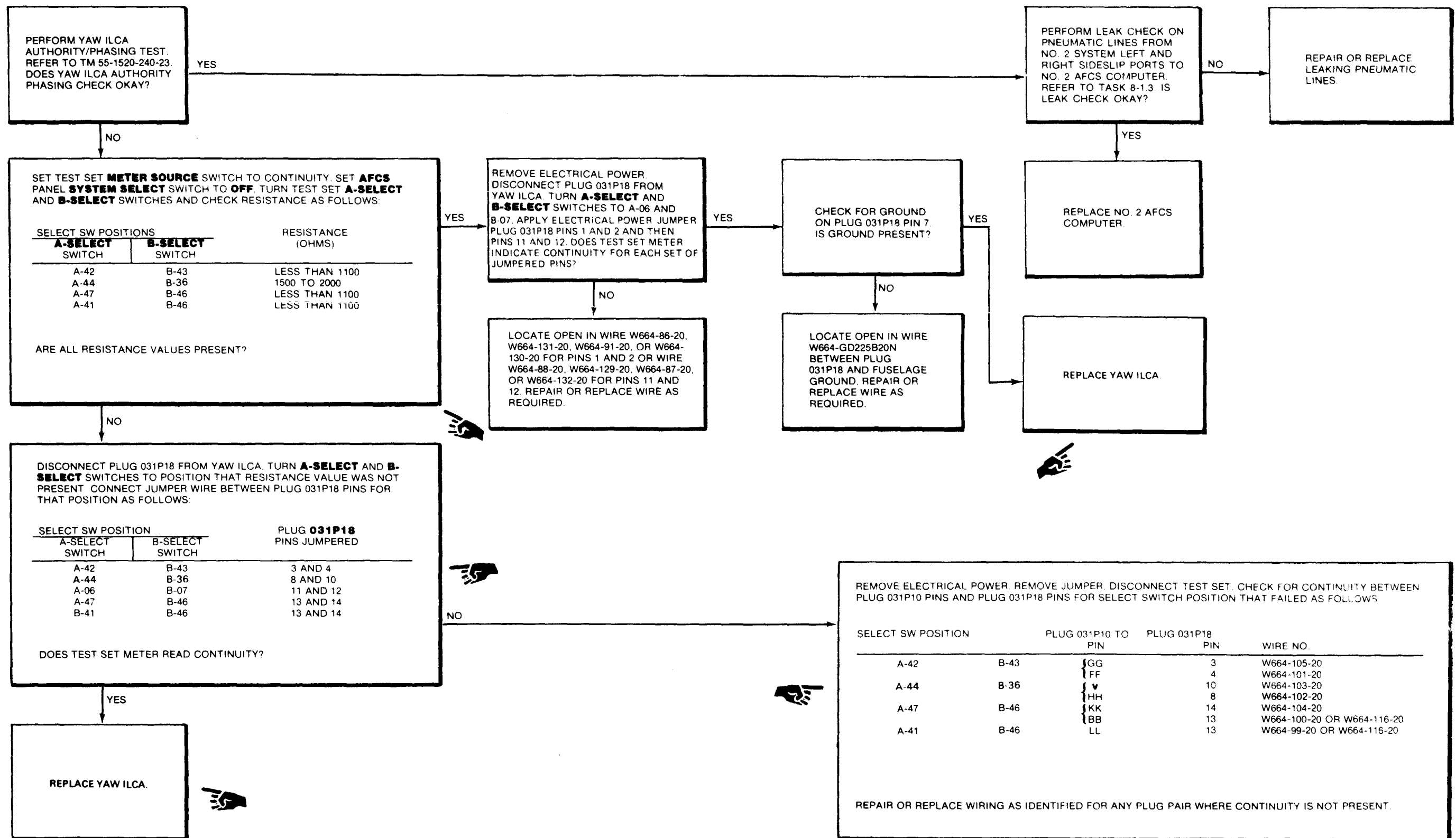

END OF TASK

11-3.59 AFCS HEADING HOLD WEAK OR INOPERATIVE

FAULT ISOLATION PROCEDURE

INITIAL SETUP

Applicable Configurations:

All

Tools:

Electrical Repairer's Tool Kit,
NSN 5180-00-323-4915
Multimeter

Materials:

None

Personnel Required:

35K10 Avionic Mechanic
35k20 Avionic Mechanic

References:

TM 55-1520-240-23
TM 55-4920-429-13

Equipment Condition:

TM 55-1520-249-23
Battery Connected
Electrical Power On
Hydraulic Power On
TM 55-4920-429-13
AFCS Line Test Set 146G0009-1
Prepared For Use

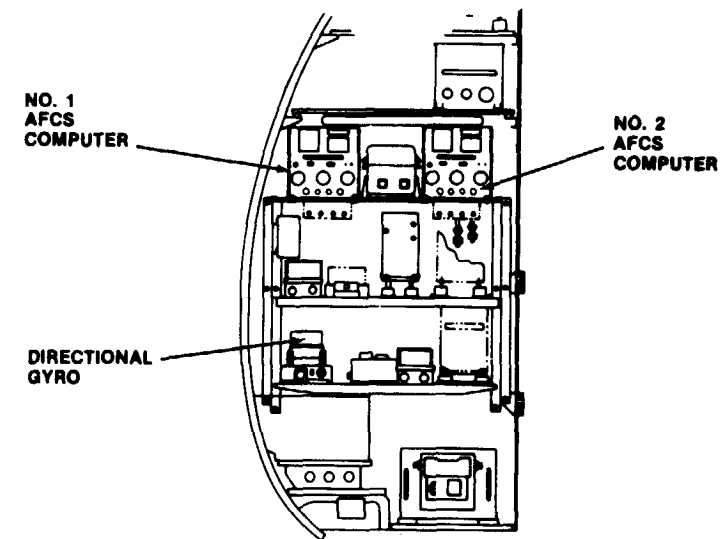
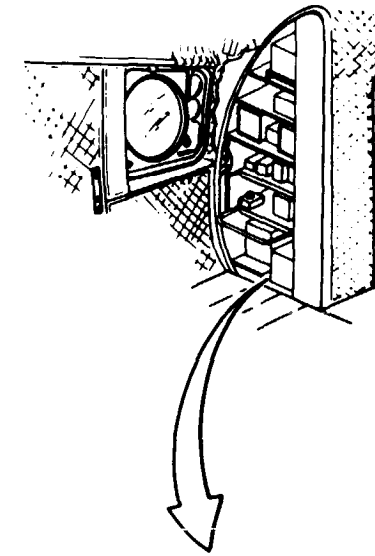

NO. 1 AFCS HEADING HOLD WEAK OR INOPERATIVE

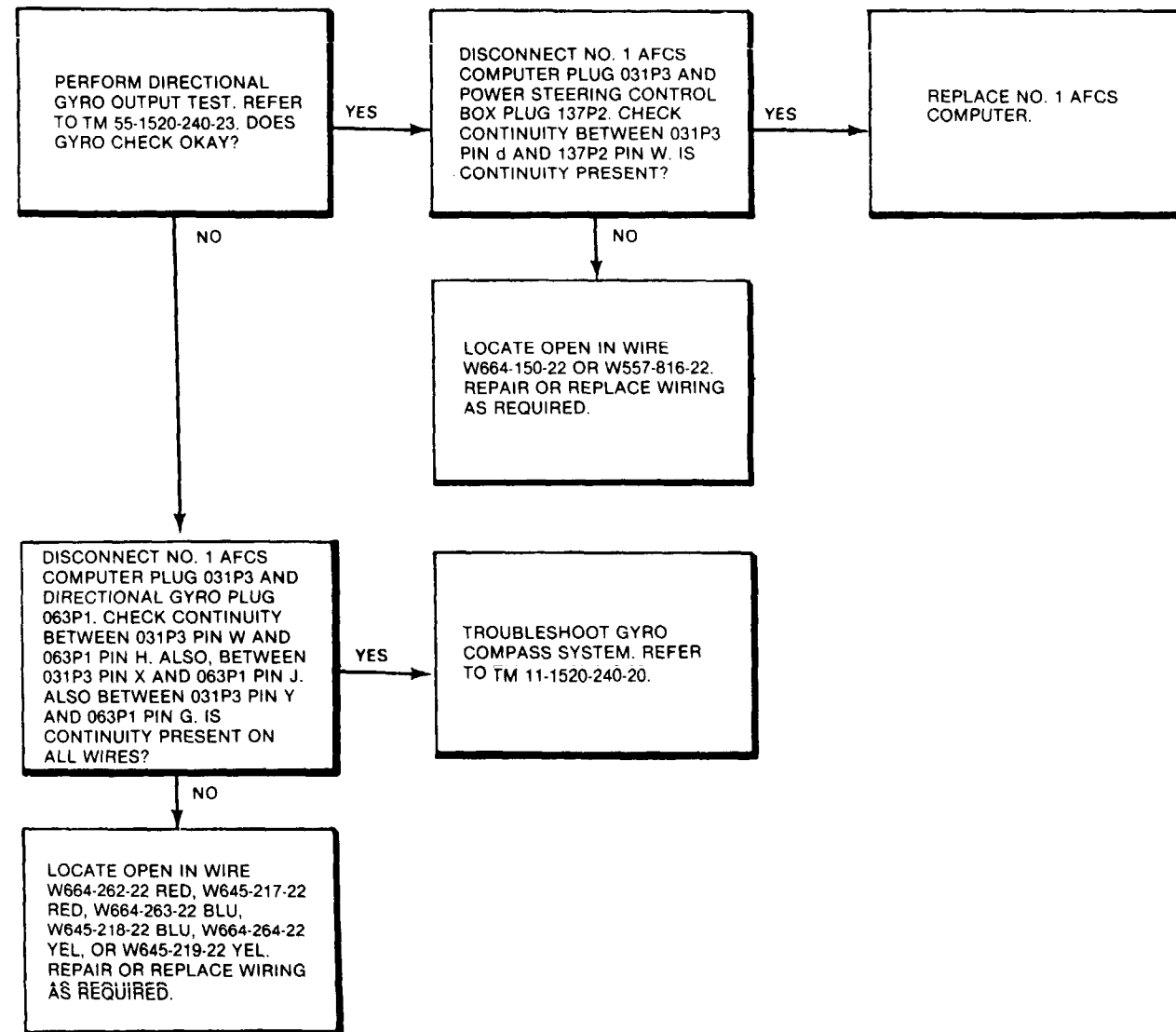

NO. 2 AFCS HEADING HOLD WEAK OR INOPERATIVE

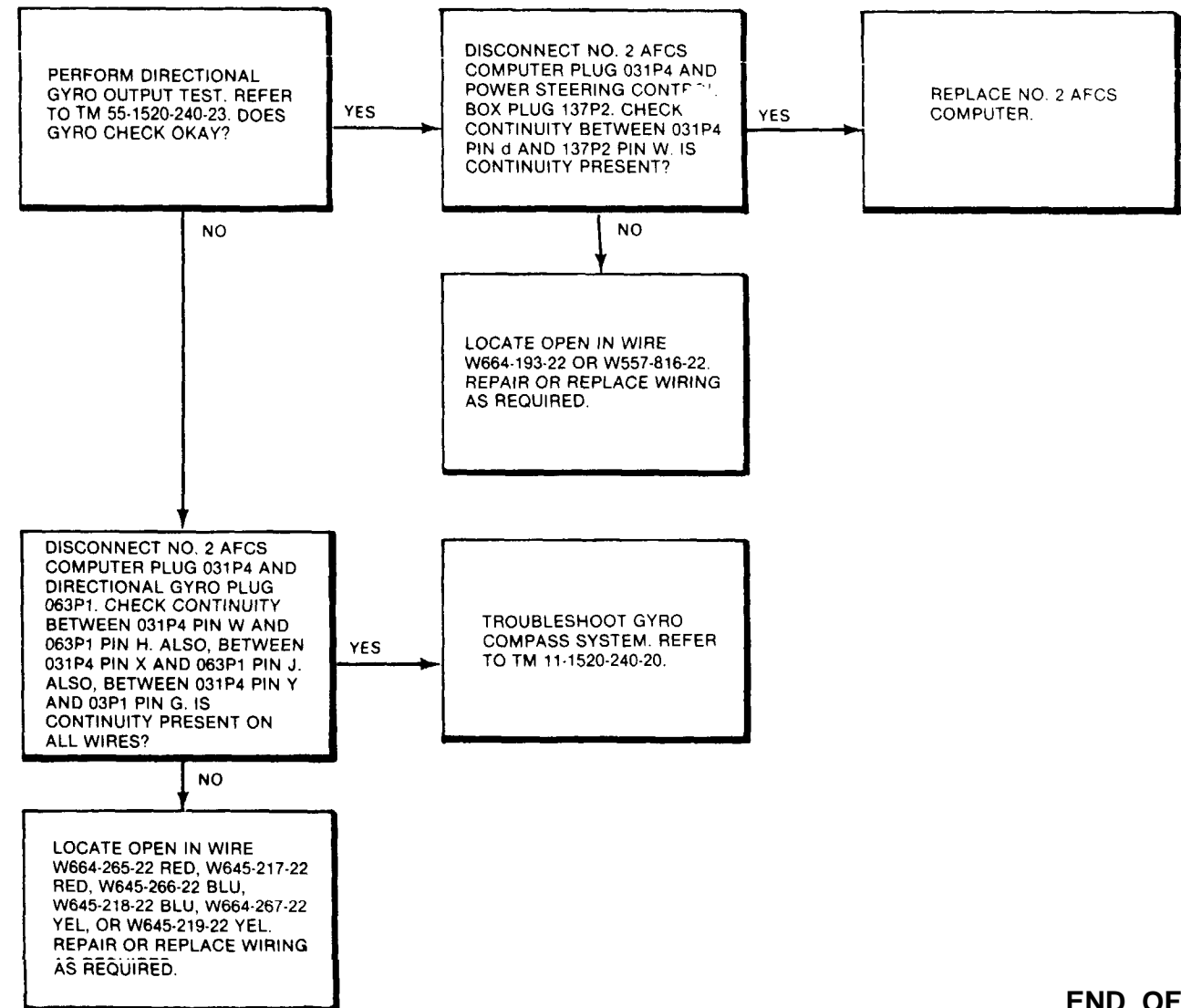

END OF TASK

FAULT ISOLATION PROCEDURE

INITIAL SETUP

Personnel Required:
68F20 Aircraft Electrician

Applicable Configurations:
All

References:
TM 55-1520-240-23

Tools:
Electrical Repairer's Tool Kit,
NSN 5180-00-323-4915

Equipment Condition:
TM 55-1520-240-23
Battery Disconnected
Electrical Power Off
Hydraulic Power Off

Materials:
None

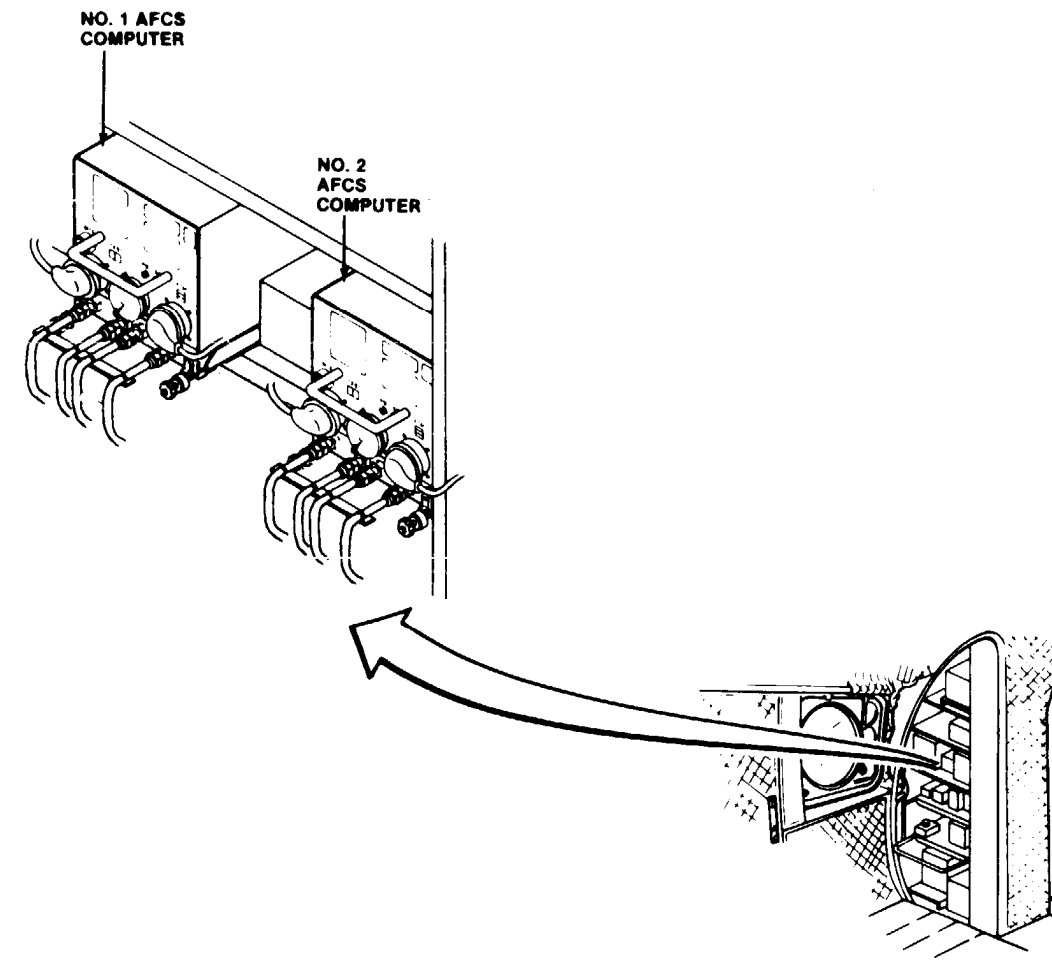

45X54

D145-11936-SPA

GO TO NEXT PAGE

11-3.60 AFCS LATERAL STICK ONLY TURNS NOT COORDINATED
(Continued)

11-3.60

**NO. 1 AFCS LATERAL STICK ONLY TURNS
NOT COORDINATED**

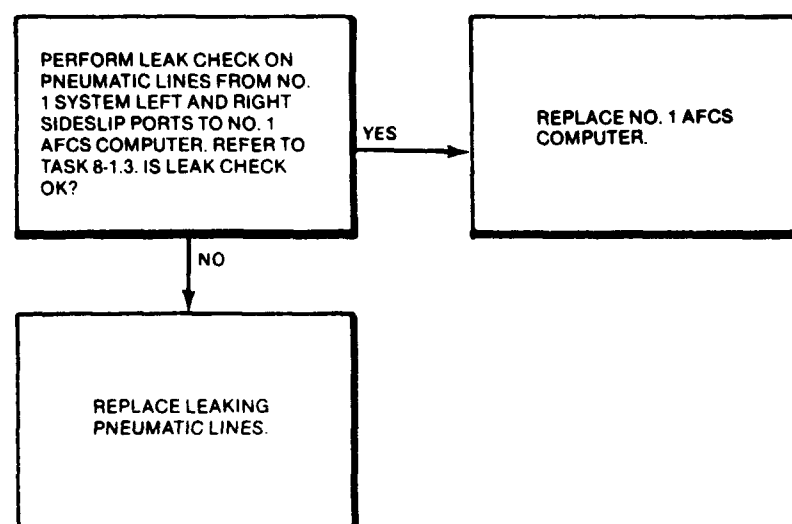

**NO. 2 AFCS LATERAL STICK ONLY TURNS
NOT COORDINATED**

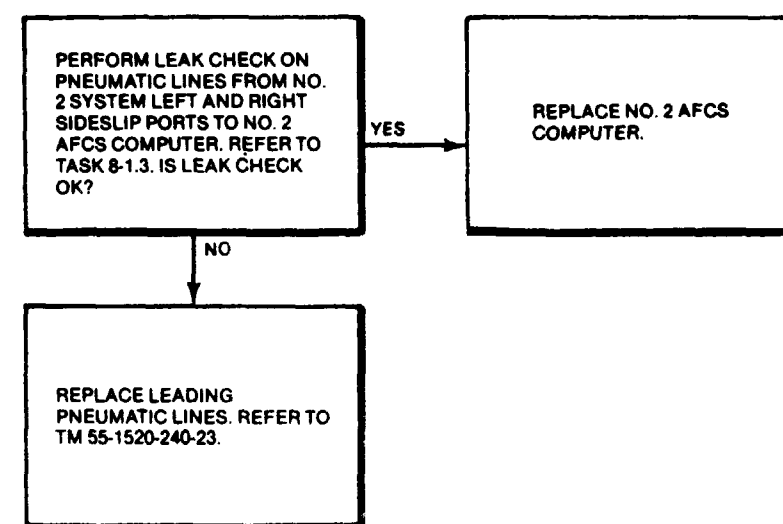

END OF TASK

FAULT ISOLATION PROCEDURE

INITIAL SETUP

Applicable Configurations:

All

Tools:

Electrical Repairer's Tool Kit,
NSN 5180-00-323-4915
Multimeter

Materials:

None

Personnel Required:

Avionic Mechanic (2)

References:

TM 55-1520-240-23
TM 55-4920-429-13

Equipment Condition:

TM 55-1520-240-23:
Battery Connected
Electrical Power On
Hydraulic Power On
TM 55-4920-429-13
AFCS Line Test Set 145G0009-1 Prepared
for Use

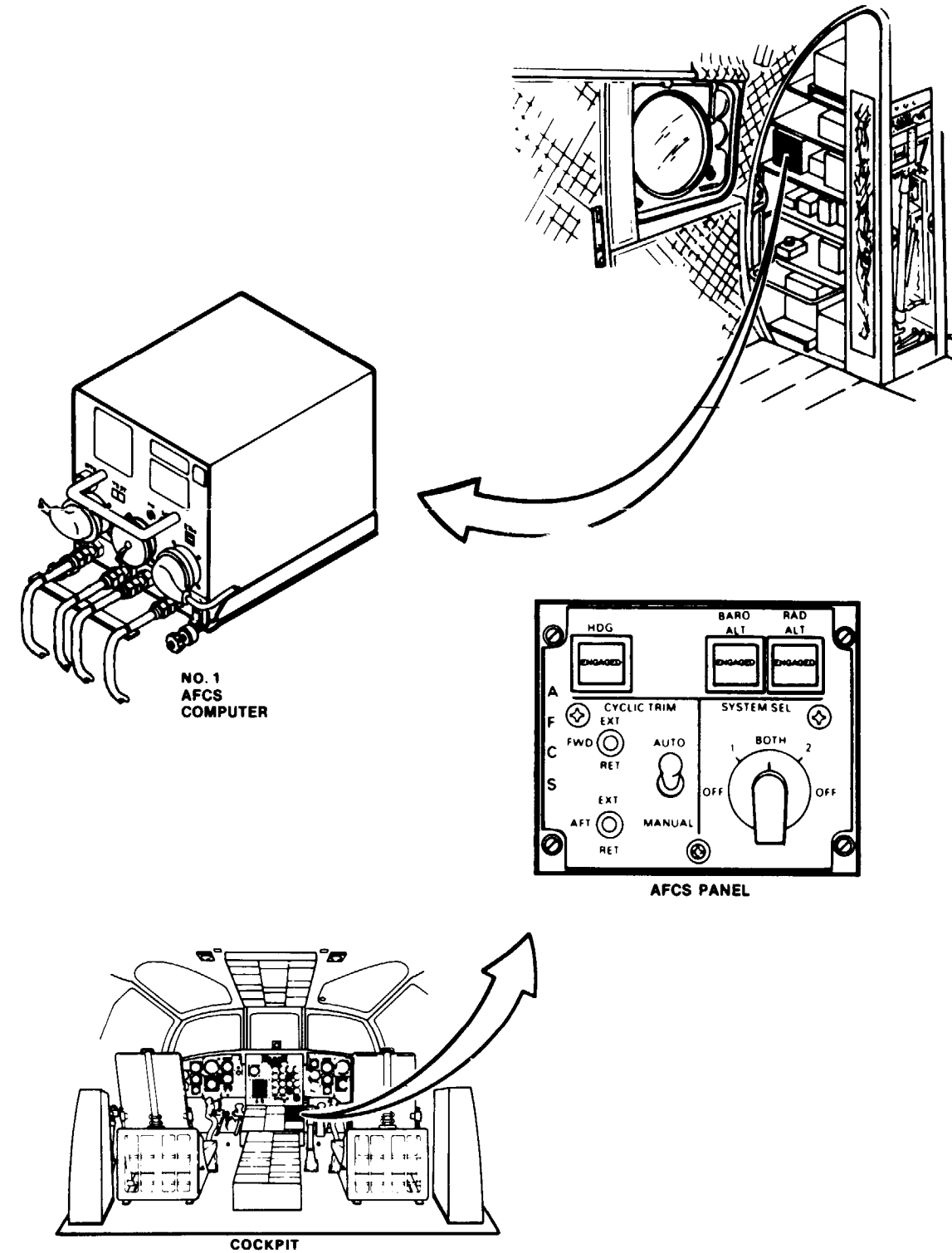
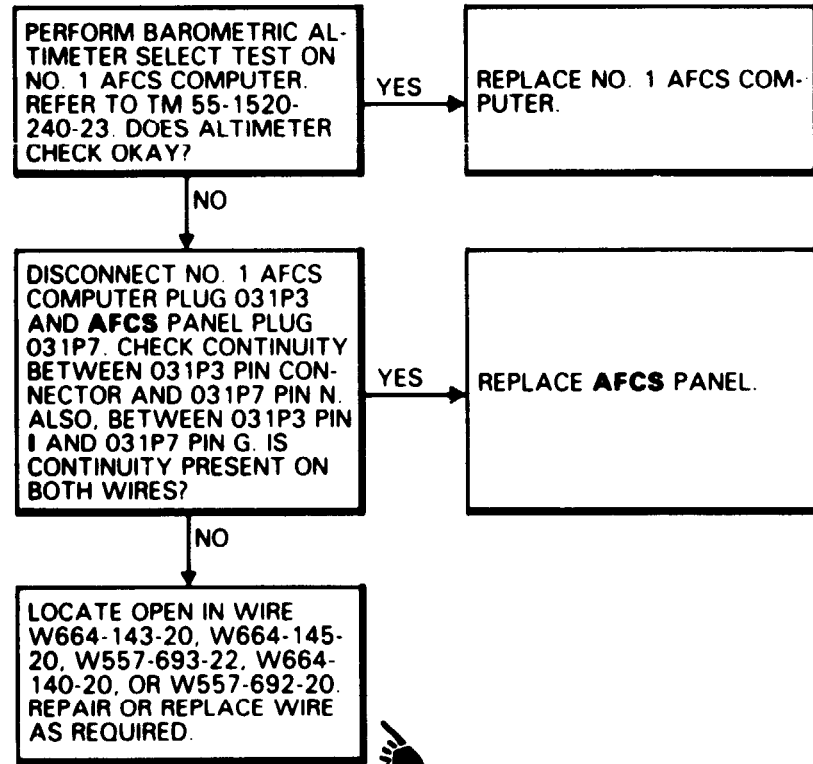

11-3.62 RADAR ALTITUDE HOLD INOPERATIVE OR RESPONSE ERRATIC
(BAROMETRIC ALTITUDE HOLD OKAY)

FAULT ISOLATION PROCEDURE

INITIAL SETUP

Applicable Configurations:

All

Tools:

Electrical Repairer's Tool Kit,
NSN 5180-00-323-4915
Multimeter

Materials:

None

Personnel Required:

35K10 Avionic Mechanic
35K20 Avionic Mechanic

References:

TM 55-1520-240-23
TM 55-4920-429-13

Equipment Condition:

TM 55-1520-240-23
Battery Connected
Electrical Power On
Hydraulic Power Off
TM 55-4920-429-13
AFCS Line Test Set 145G0009-1
Prepared for Use.

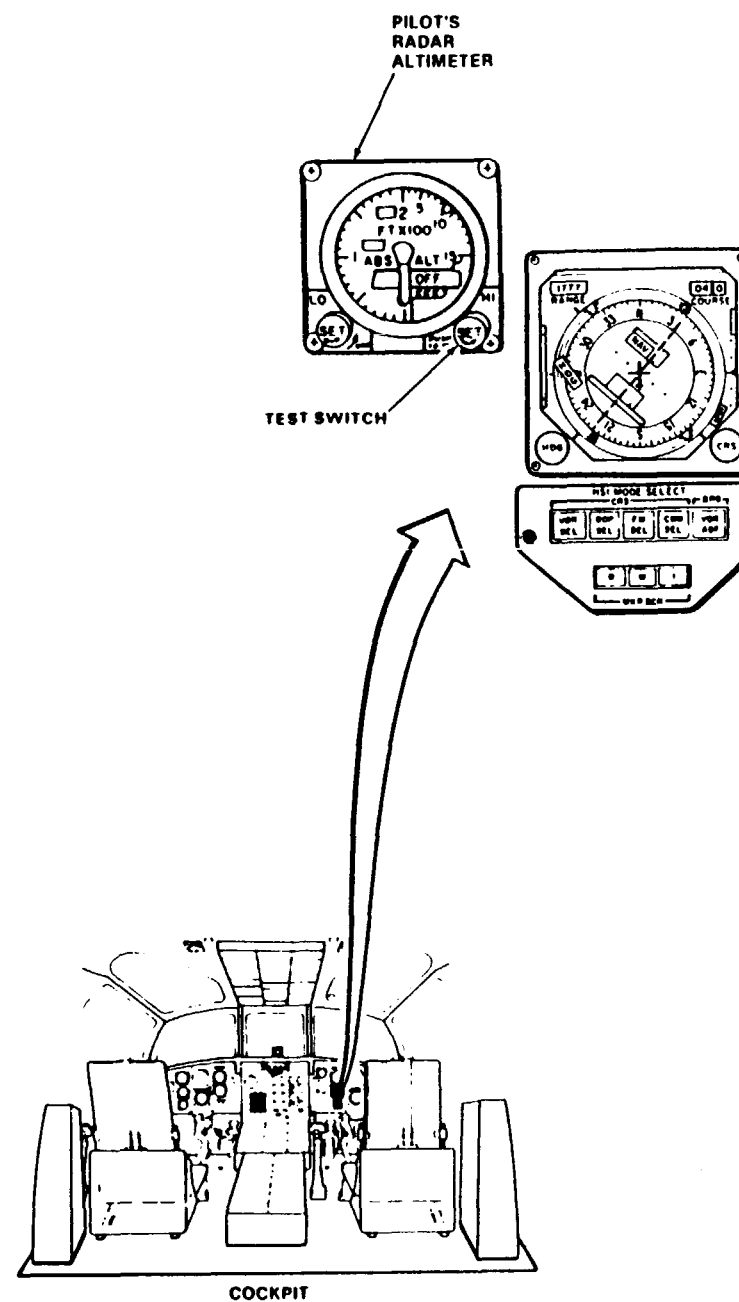
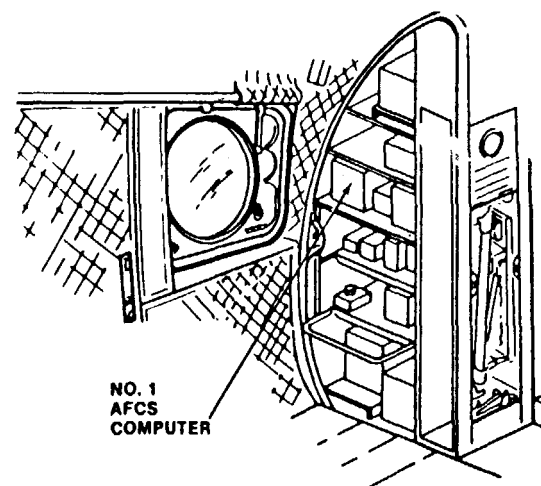

11-3.62 RADAR ALTITUDE HOLD INOPERATIVE OR RESPONSE ERRATIC (BAROMETRIC ALTITUDE HOLD OKAY) (Continued)

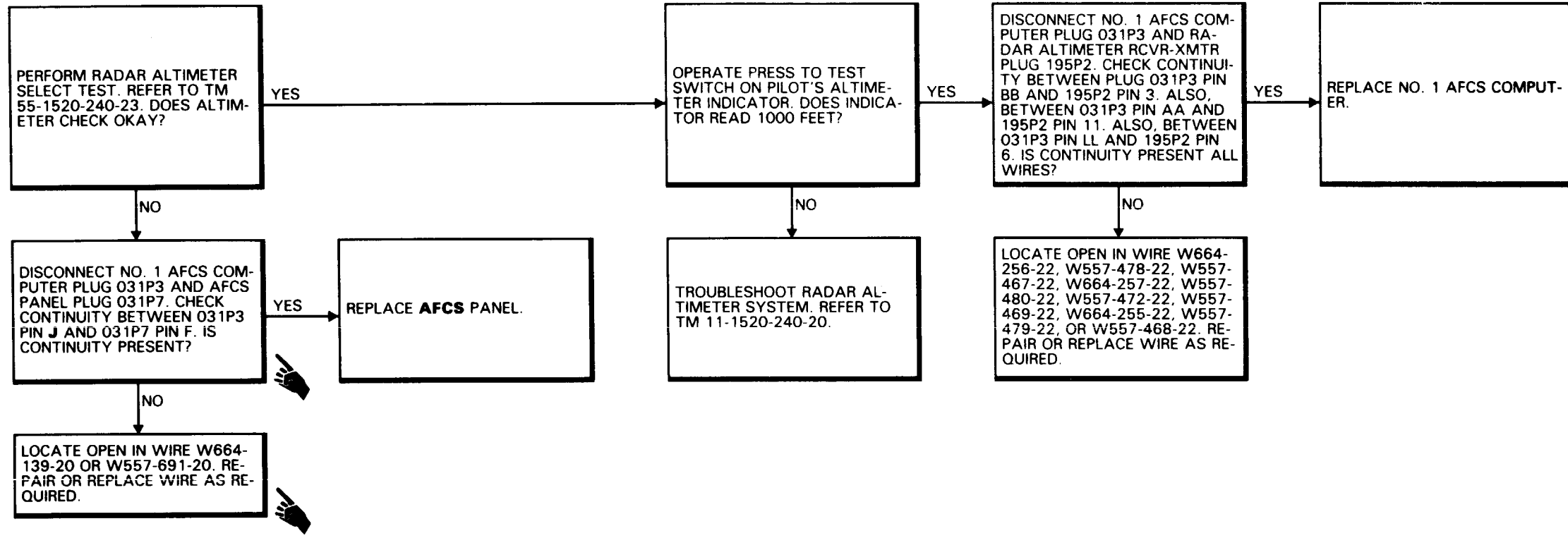

11-3.63 BAROMETRIC AND RADAR ALTITUDE HOLD INOPERATIVE OR RESPONSE ERRATIC

FAULT ISOLATION PROCEDURE

INITIAL SETUP

Applicable Configurations:
All

Tools:
Electrical Repairer's Tool Kit,
NSN 5180-00-323-4915
Multimeter

Materials:
None

Personnel Required:

35K10 Avionic Mechanic
35K20 Avionic Mechanic

References:

TM 55-1520-240-23
TM 55-4920-429-13

Equipment Condition:

TM 55-1520-240-23
Battery Connected
Electrical Power On
Hydraulic Power On
TM 55-4920-429-13
AFCS Line Test Set 145G0009-1
Prepared for Use

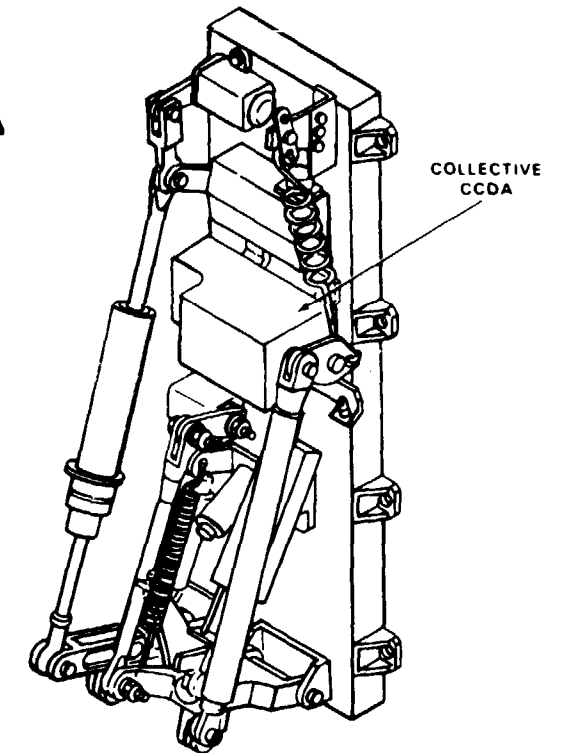
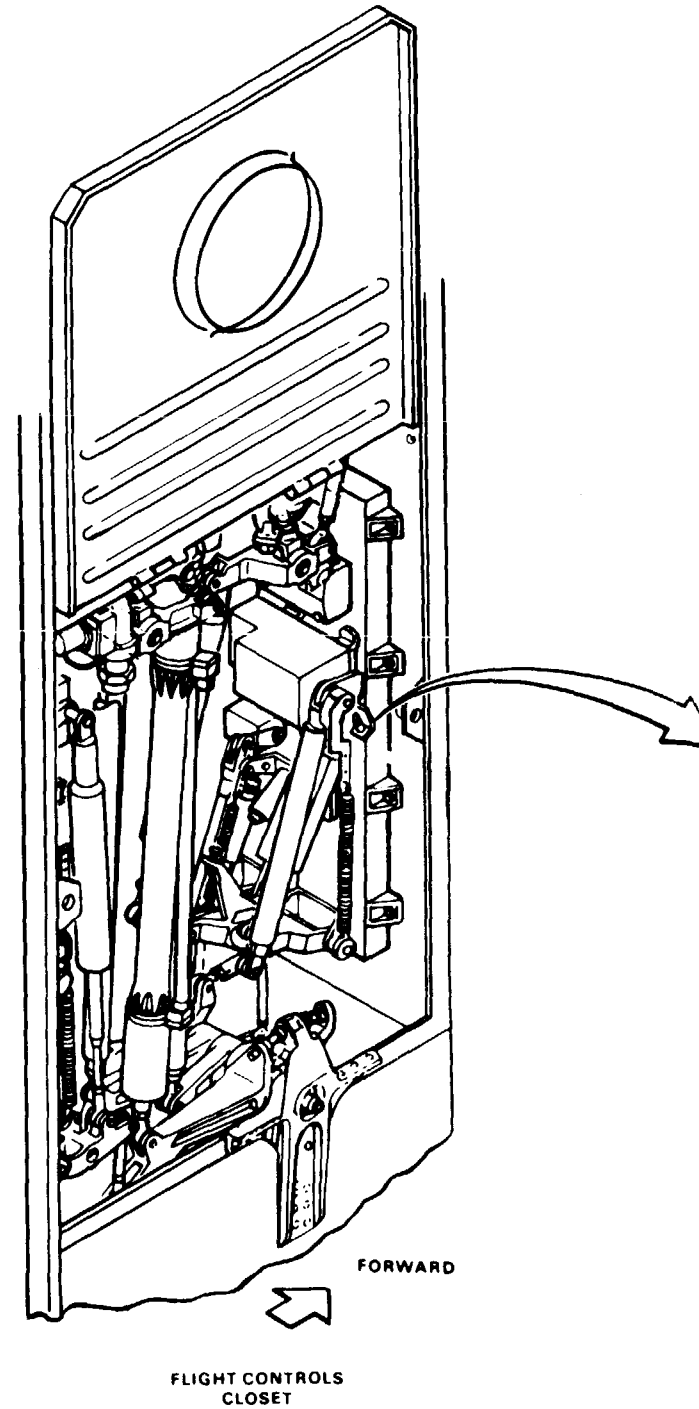
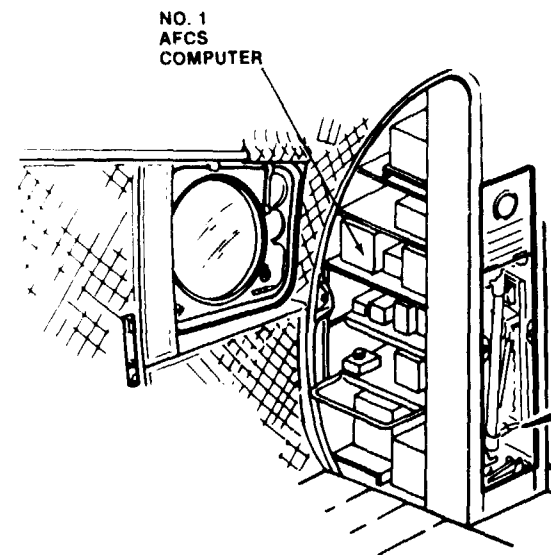

11-3.63 BAROMETRIC AND RADAR ALTITUDE HOLD INOPERATIVE OR
RESPONSE ERRATIC (Continued)

11-3.63

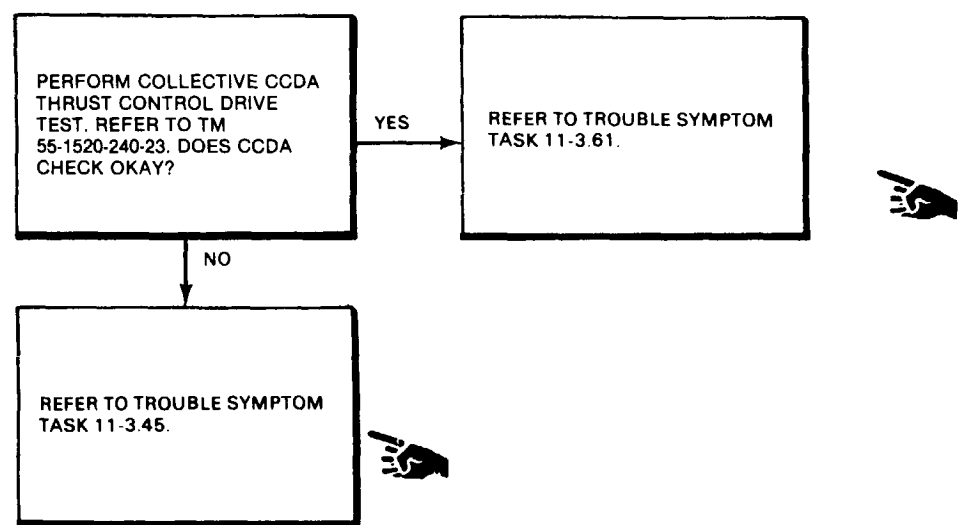

END OF TASK

11-4 AFCS CONTROL PANEL

11-4 AFCS CONTROL PANEL

11-4.1 AFCS CONTROL PANEL WIRING DIAGRAM

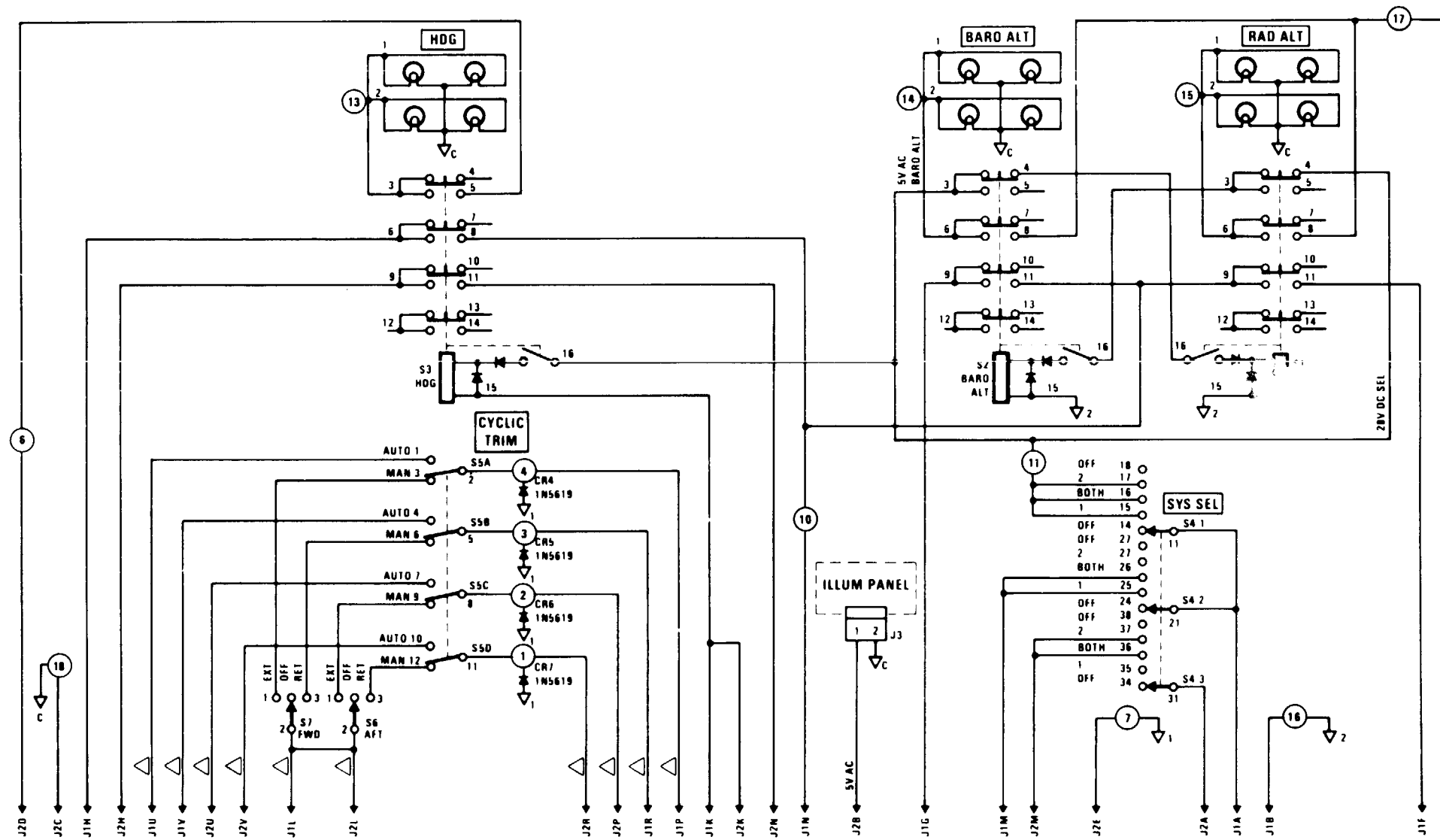

NOTE

1. INDICATES EQUIPMENT MARKING
2. INDICATES NUMBERED PAD ON PRINTED WIRING BOARD
3. ALL WIRE NO. 22 EXCEPT FOR Δ WHICH IS NO. 20

11-4.2 AFCS CONTROL PANEL VISUAL CHECK

INITIAL SETUP

Applicable Configurations:

All

Tools:

Electronic Repairer's Tool Kit,
NSN 5180-00-064-5178
Multimeter

Materials:

None

Personnel Required:

35M20 Avionic Navigation and Flight Control
Equipment Repairer.

References:

TM 55-1520-240-23

Equipment Condition:

AFCS Control Panel Disconnected From AFCS
Bench Test Set

AFCS Control Panel Rear Cover Removed

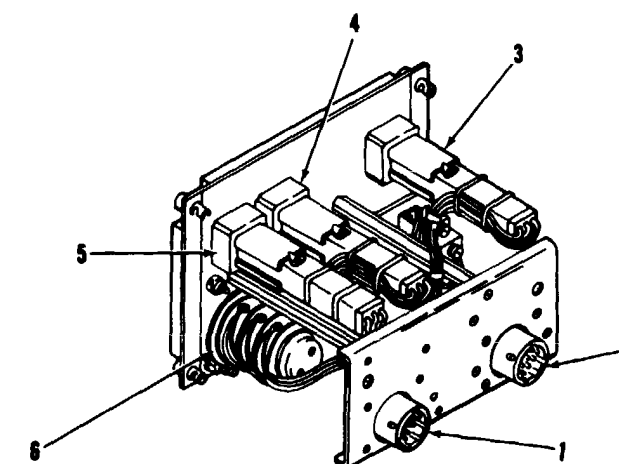

AFCS CONTROL PANEL
WITH REAR COVER
REMOVED.

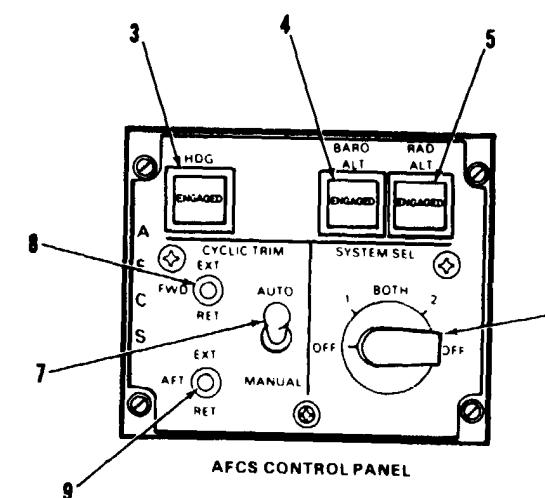

AFCS CONTROL PANEL

TASK	RESULT
1. Check pins in receptacles (1 and 2).	If any pin is bent, straighten it. If any pin is broken, corroded, or burnt, replace it.
2. Check switches (3 thru 9).	If any switch is loose or damaged, tighten or replace it as required. If knob on switch (6) is loose, tighten or replace it.
3. Check panel wires.	If any wire termination is loose, tighten it. If any wire is damaged, replace it.

FOLLOW-ON MAINTENANCE:

None

FAULT ISOLATION PROCEDURE

INITIAL SETUP

Applicable Configurations:

All

Tools:

Electronic Repairer's Tool Kit,
NSN 5180-00-064-5178
Multimeter

Materials:

None

Personnel Required:

35M20 Avionic Navigation and Flight Control
Equipment Repairer.

References:

TM 55-1520-240-23

Equipment Condition:

Visual Check of AFCS Control Panel Performed
(Task 11-4.2)

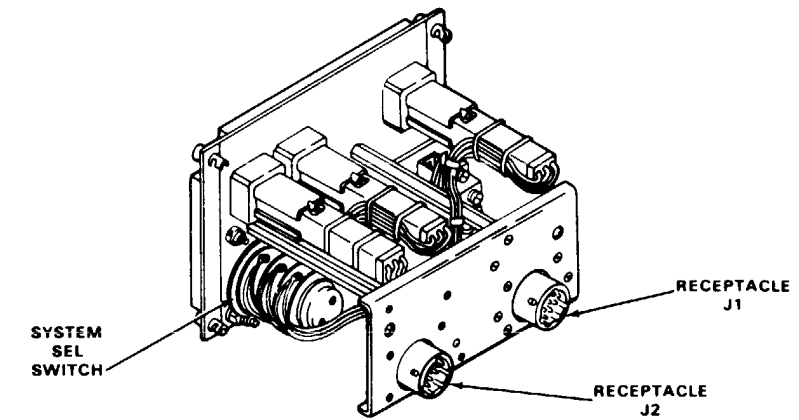

AFCS CONTROL PANEL
WITH REAR COVER
REMOVED.

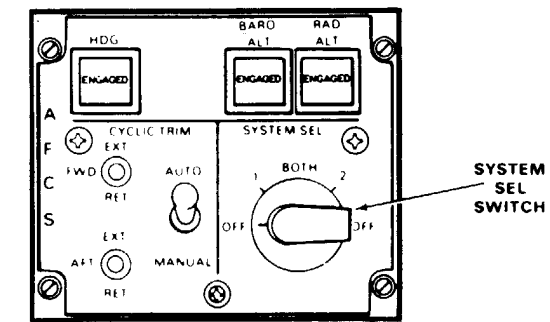
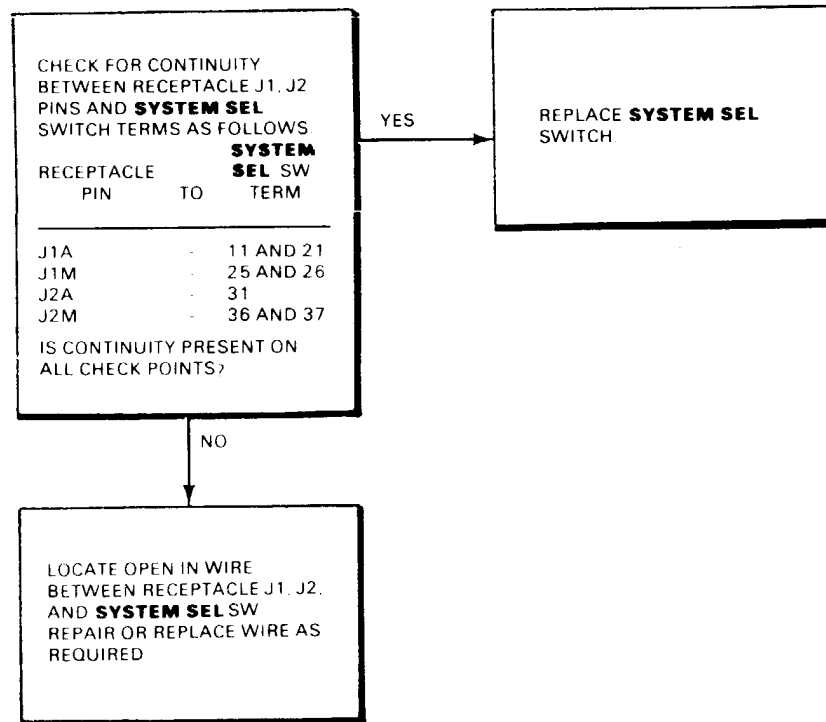

AFCS CONTROL PANEL

11-4.4 AFCS CONTROL PANEL FAILS RADAR ALTITUDE TESTS

FAULT ISOLATION PROCEDURE

INITIAL SETUP

Applicable Configurations:

All

Tools:

Electronic Repairer's Tool Kit,
NSN 5180-00-064-5178
Multimeter

Materials:

None

Personnel Required:

35M20 Avionic Navigation and Flight Control
Equipment Repairer.

References:

TM 55-1520-240-23

Equipment Condition:

Visual Check of AFCS Control
Panel Performed (Task 11-4.2)

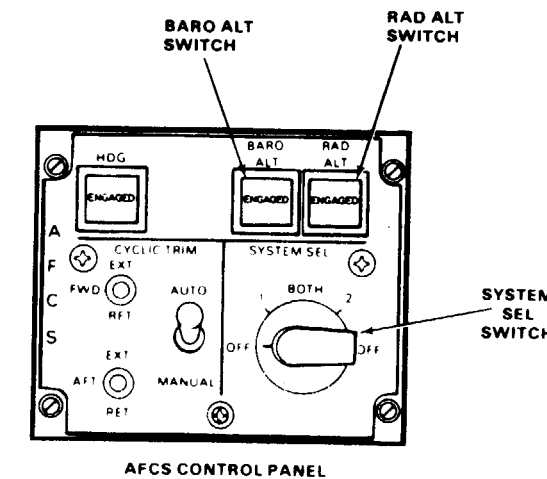
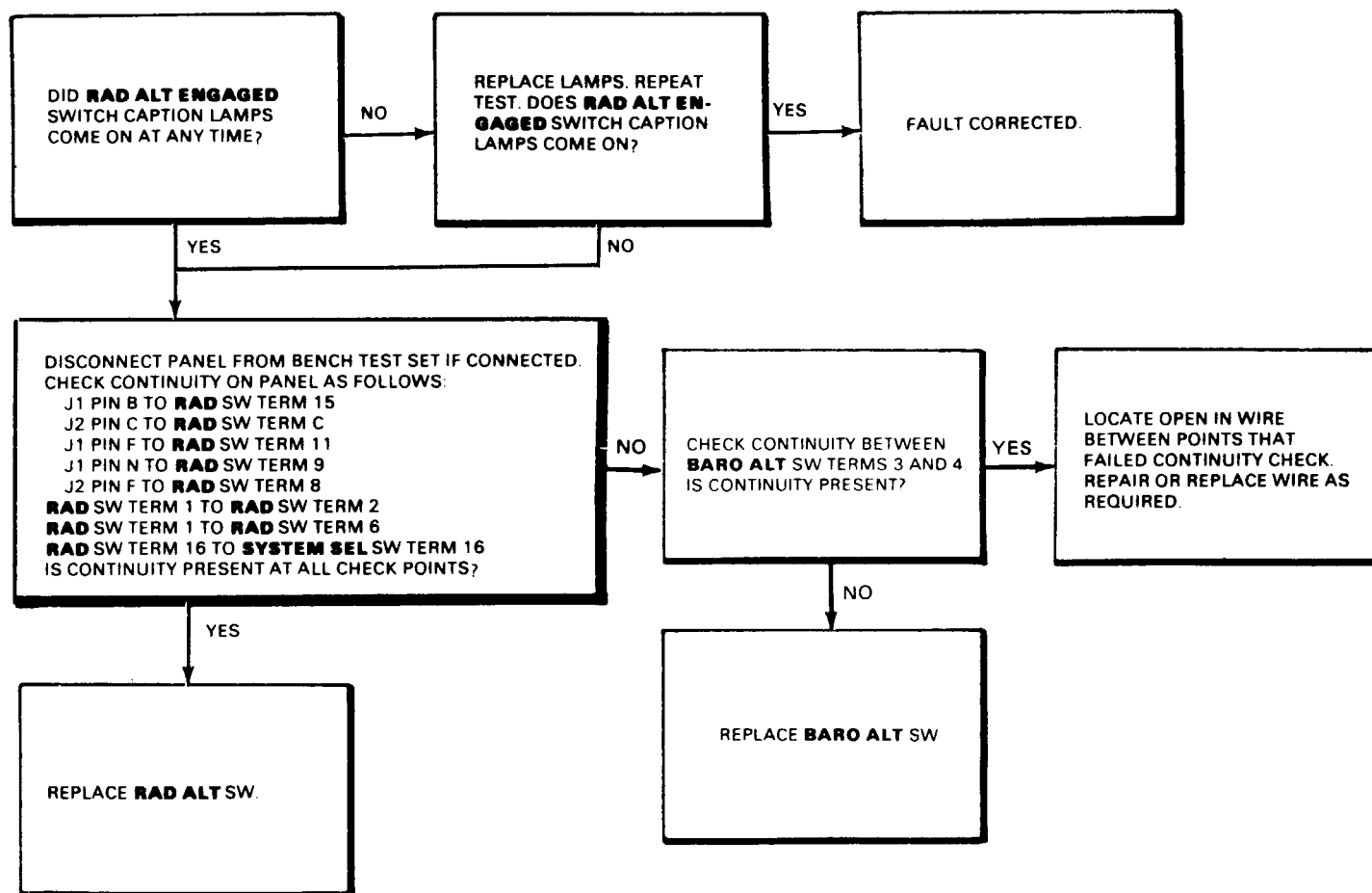
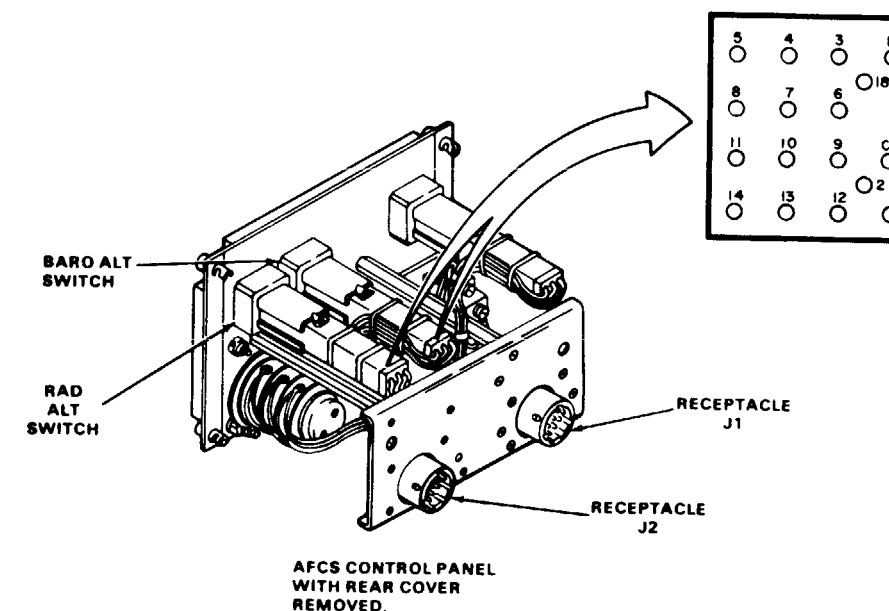

FAULT ISOLATION PROCEDURE

INITIAL SETUP

Applicable Configurations:

All

Tools:

Electronic Repairer's Tool Kit,
NSN 5180-00-064-5178
Multimeter

Materials:

None

Personnel Required:

Avionic Navigation and Flight Control Equipment
Repairer

References:

TM 55-1520-240-23

Equipment Condition:

Visual Check of AFCS Control Panel Performed

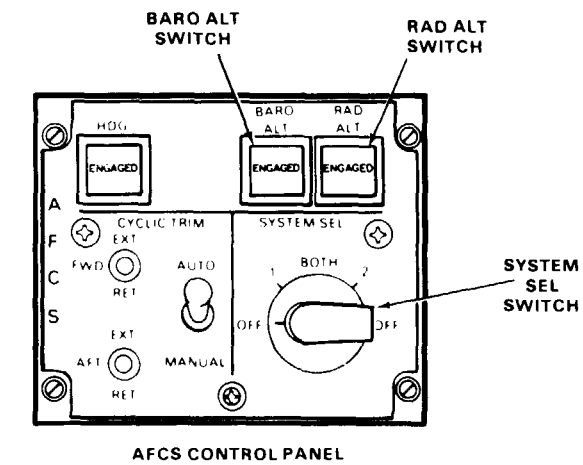
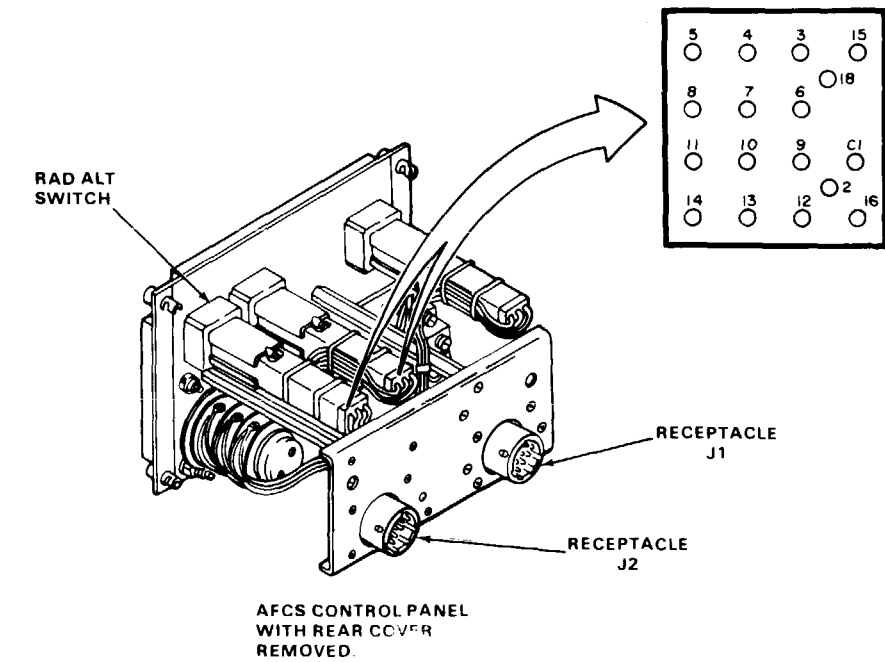
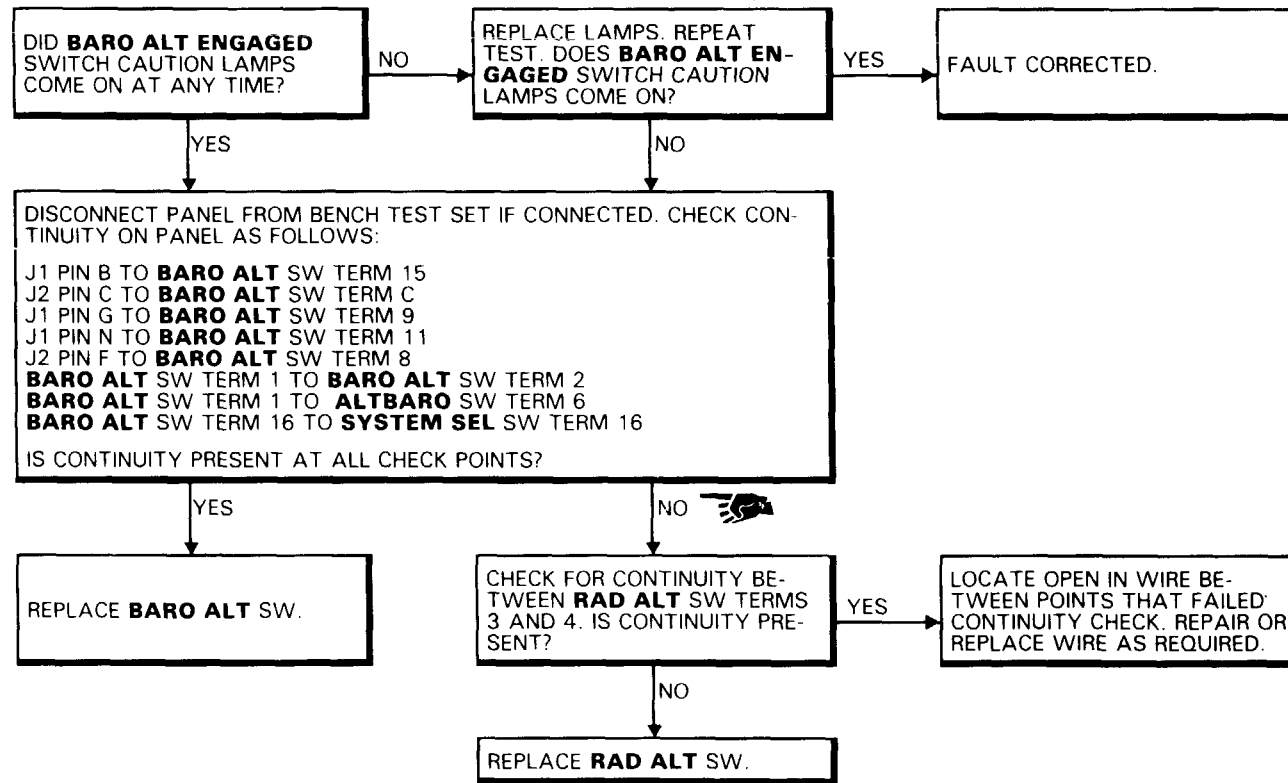

11-4.6 AFCS CONTROL PANEL FAILS HEADING TEST

FAULT ISOLATION PROCEDURE

INITIAL SETUP

Applicable Configurations:
All

Tools:
Electronic Repairer's Tool Kit,
NSN 5180-00-064-5178
Multimeter

Materials:
None

Personnel Required:
35M20 Avionic Navigation and Flight Control
Equipment Repairer.

References:
TM 55-1520-240-23

Equipment Condition:
Visual Check of AFCS Control
Panel Performed (Task 11-4.2)

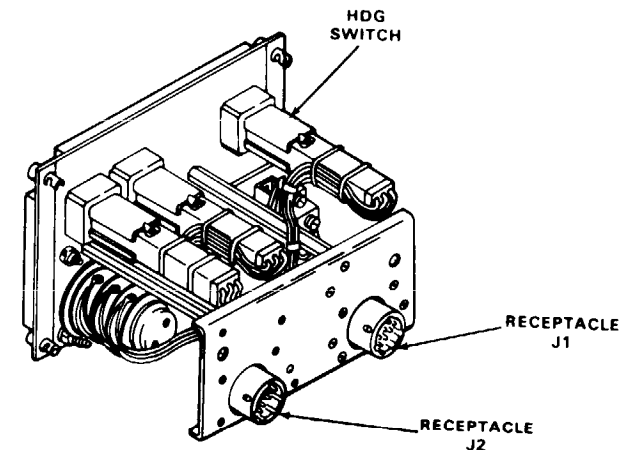

AFCS CONTROL PANEL
WITH REAR COVER
REMOVED.

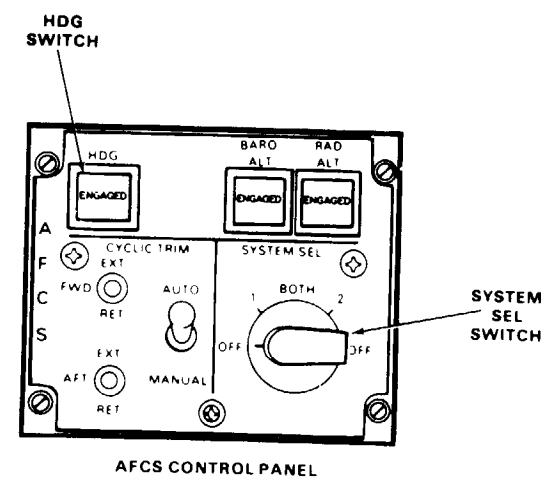

AFCS CONTROL PANEL

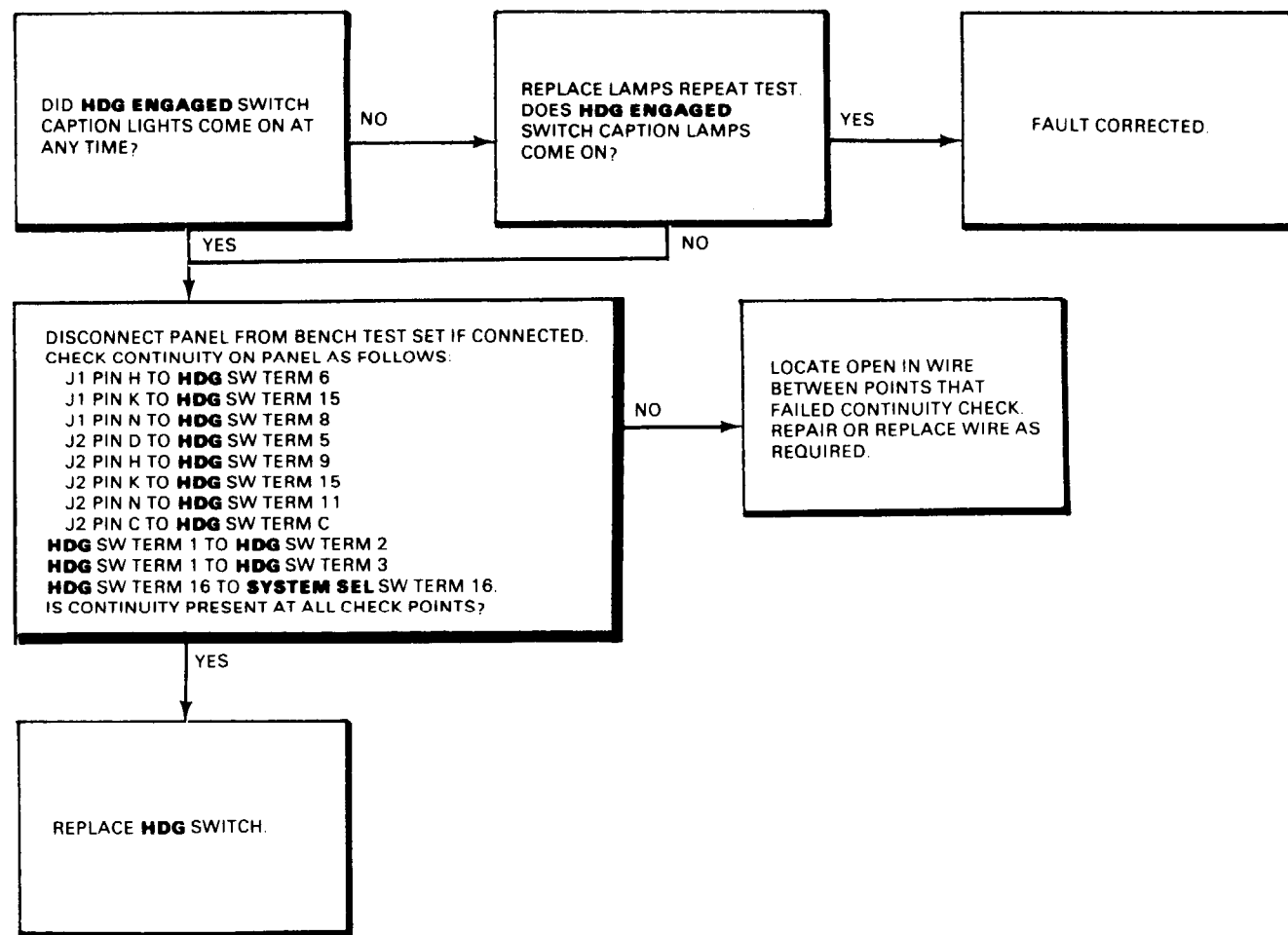

45 x 54

D145-12441-SPA

END OF TASK

FAULT ISOLATION PROCEDURE

INITIAL SETUP

Applicable Configurations:

All

Tools:

Electronic Repairer's Tool Kit,
NSN 5180-00-064-5178
Multimeter

Materials:

None

Personnel Required:

35M20 Avionic Navigation and Flight Control
Equipment Repairer.

References:

TM 55-1520-240-23

Equipment Condition:

Visual Check of AFCS Control
Panel Performed (Task 11-4.2)

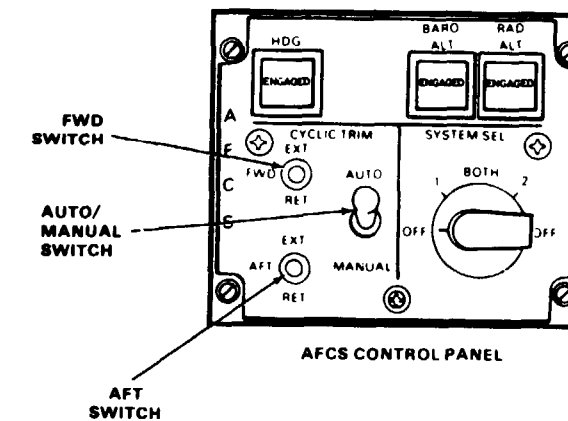
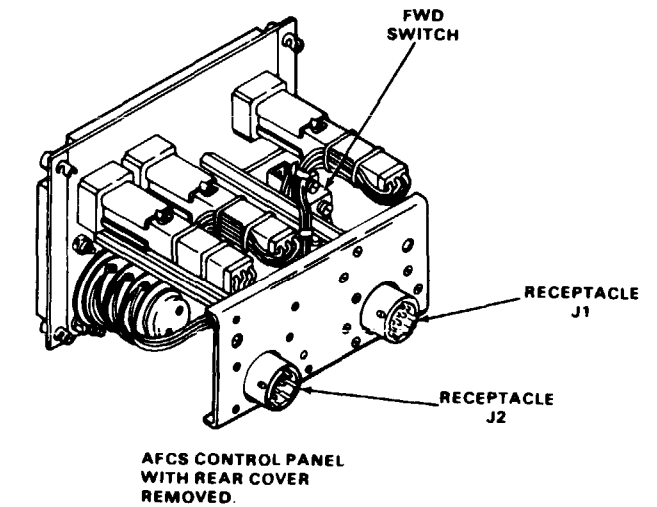
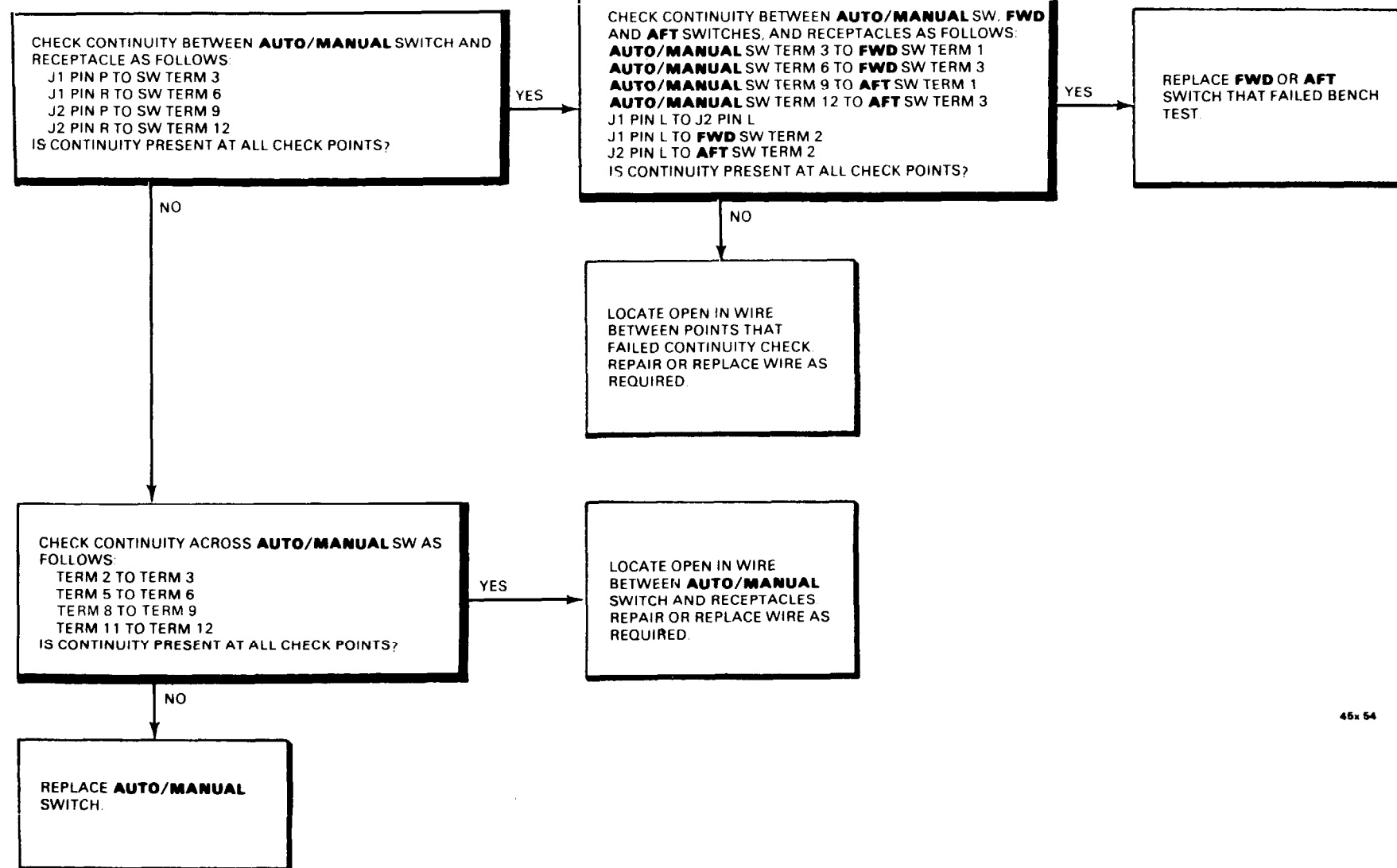

45x 54

D145-12442-SPA

END OF TASK

11-4.8 AFCS CONTROL PANEL FAILS CYCLIC TRIM - AUTOMATIC TEST

FAULT ISOLATION PROCEDURE

INITIAL SETUP

Applicable Configurations:

All

Tools:

Electronic Repairer's Tool Kit,
NSN 5180-00-064-5178
Multimeter

Materials:

None

Personnel Required:

35M20 Avionic Navigation and Flight Control
Equipment Repairer.

References:

TM 55-1520-240-23

Equipment Condition:

Visual Check of AFCS Control
Panel Performed (Task 11-4.2)

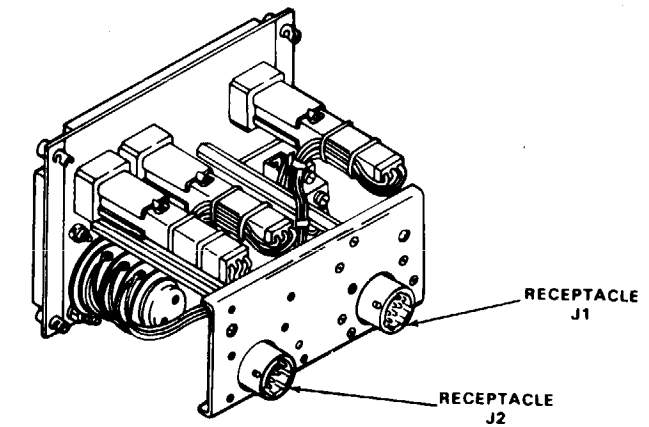

AFCS CONTROL PANEL WITH REAR COVER REMOVED.

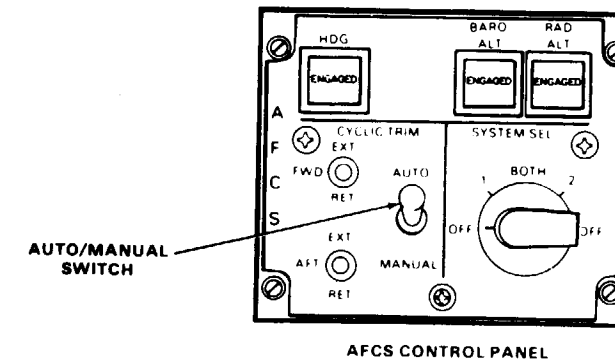
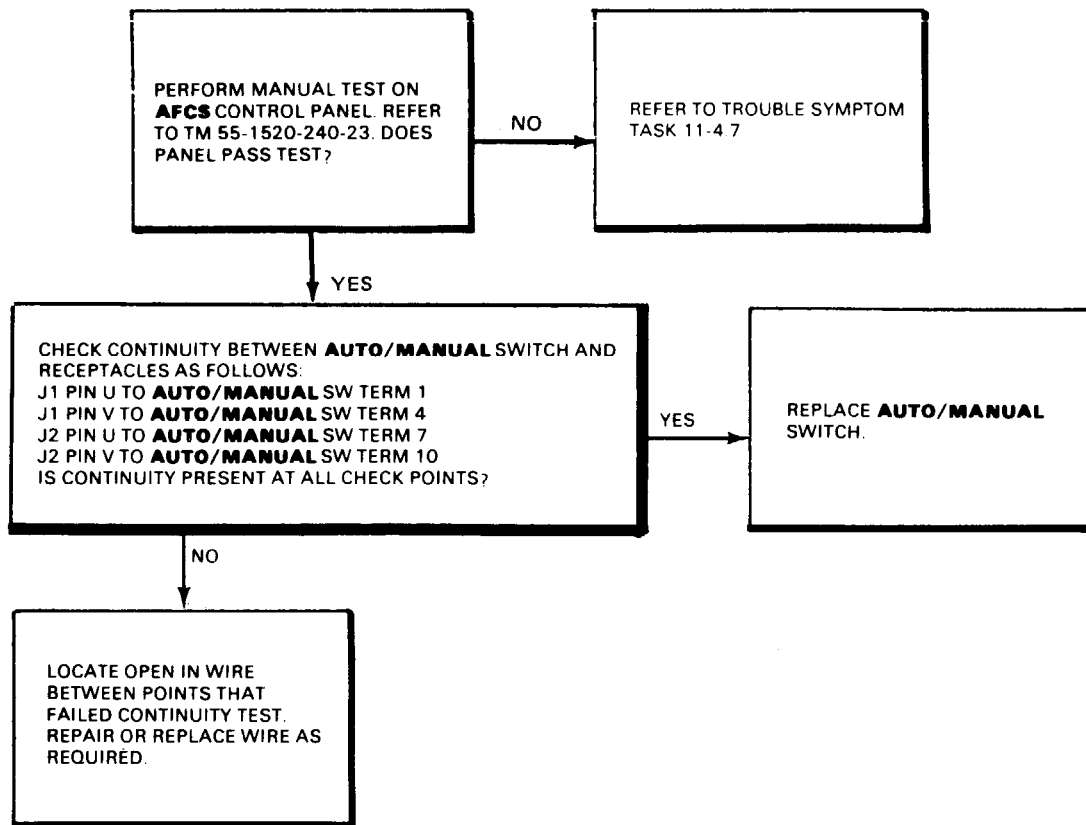

FAULT ISOLATION PROCEDURE

INITIAL SETUP

Personnel Required:

35M20 Avionic Navigation and Flight Control
Equipment Repairer.

Applicable Configurations:

All

References:

TM 55-1520-240-23

Tools:

Electronic Repairer's Tool Kit,
NSN 5180-00-064-5178
Multimeter

Equipment Condition:

Visual Check of AFCS Control
Panel Performed (Task 11-4.2)

Materials:

None

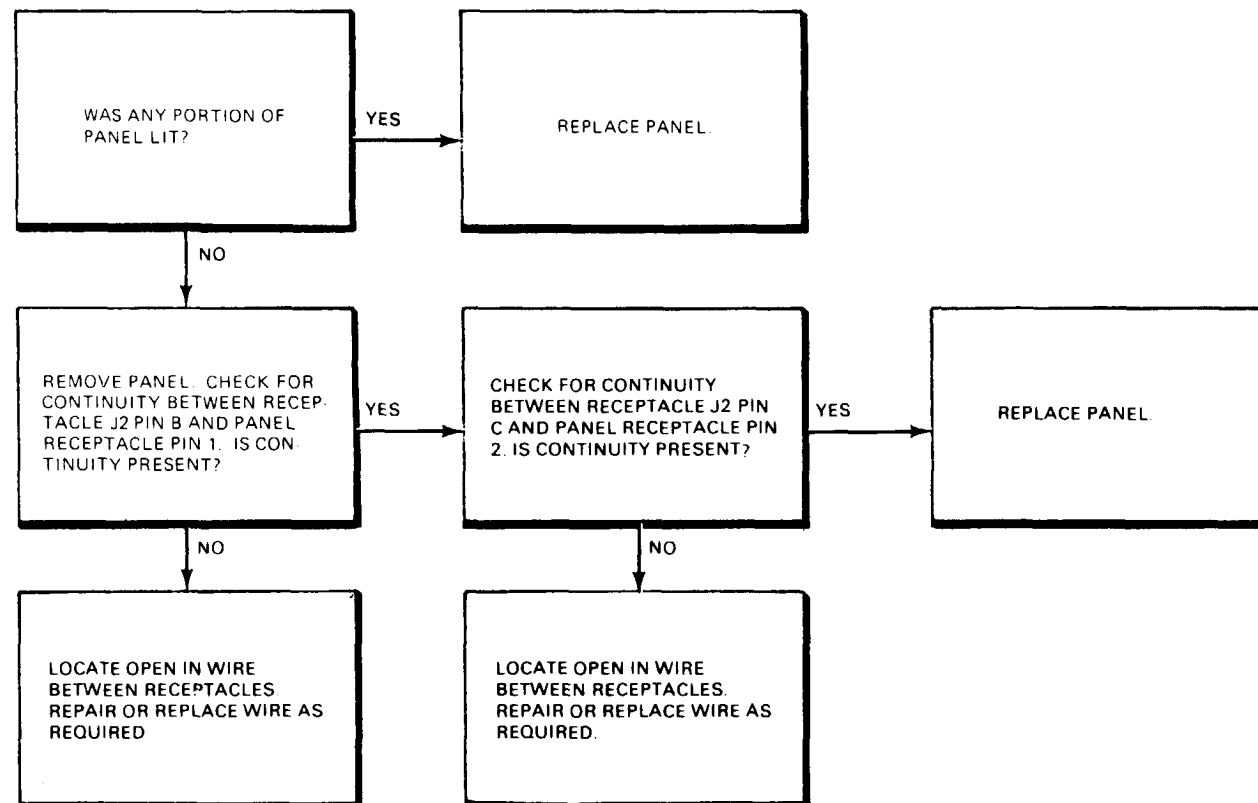
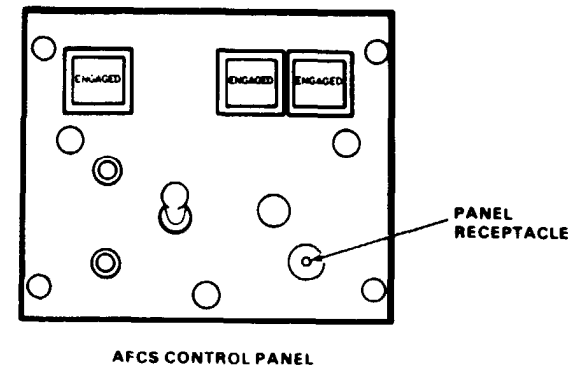
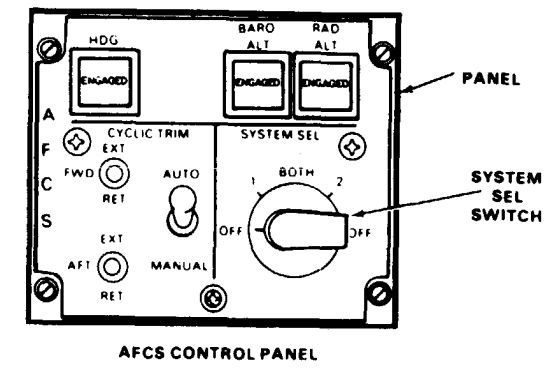

11-4.10 AFCS CONTROL PANEL FAILS DIODE TEST

FAULT ISOLATION PROCEDURE

INITIAL SETUP

Applicable Configurations:

All

Tools:

Electronic Repairer's Tool Kit,
NSN 5180-00-064-5178
Multimeter

Materials:

None

Personnel Required:

35M20 Avionic Navigation and Flight Control
Equipment Repairer.

References:

TM 55-1520-240-23

Equipment Condition:

Visual Check of AFCS Control
Panel Performed (Task 11-4.2)

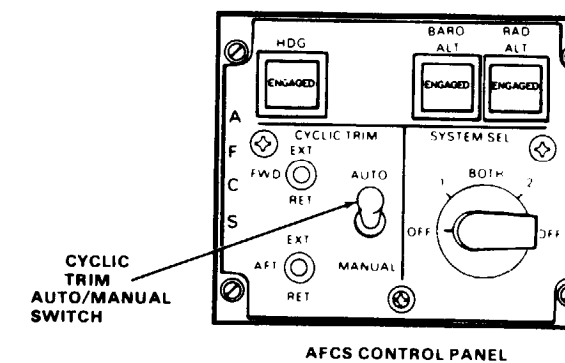
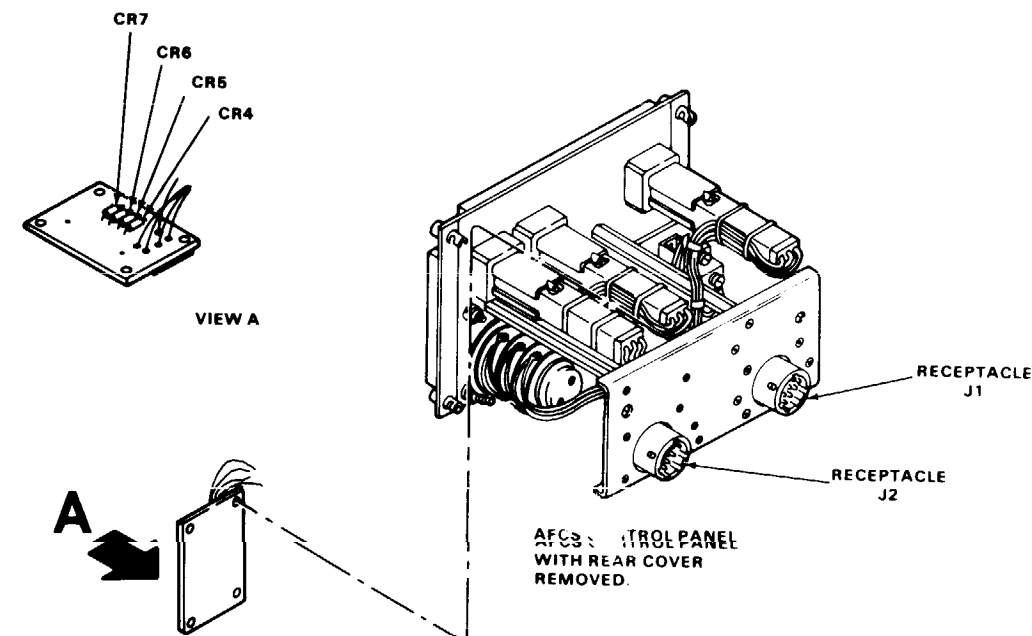
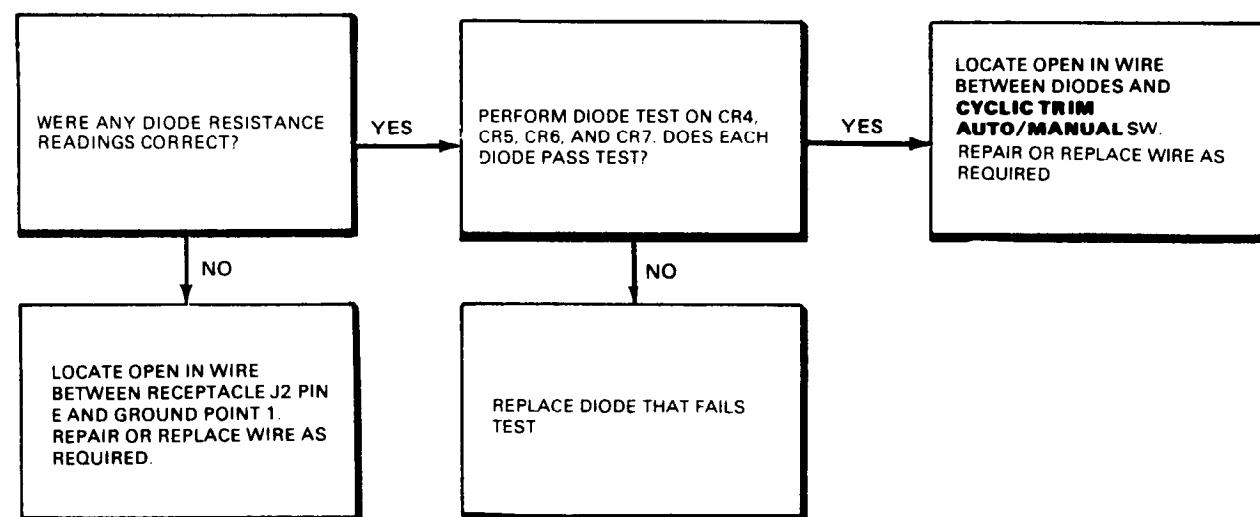

END OF TASK

11-201/(11-202 blank)

11-5 AFCS COMPUTER

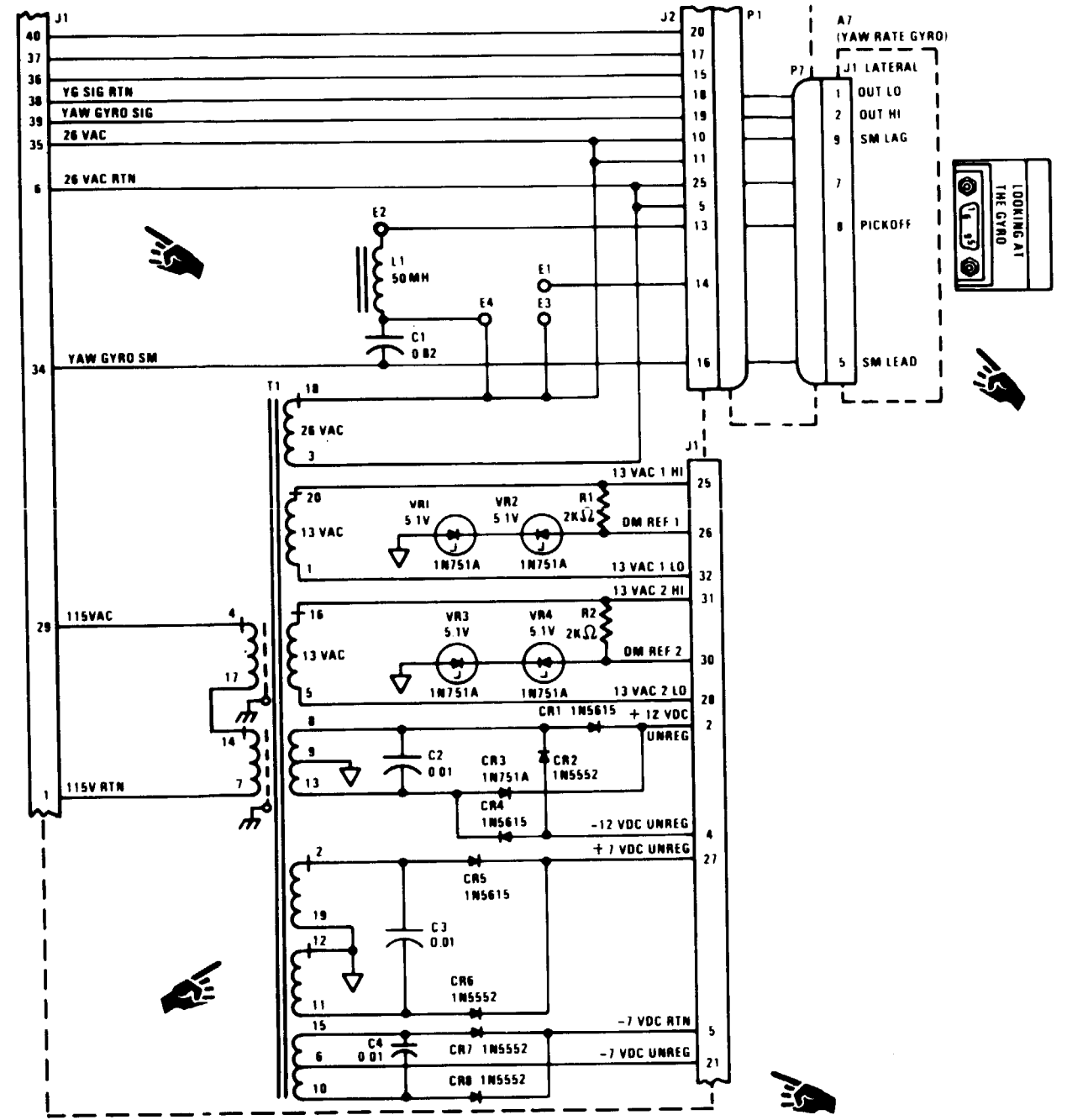
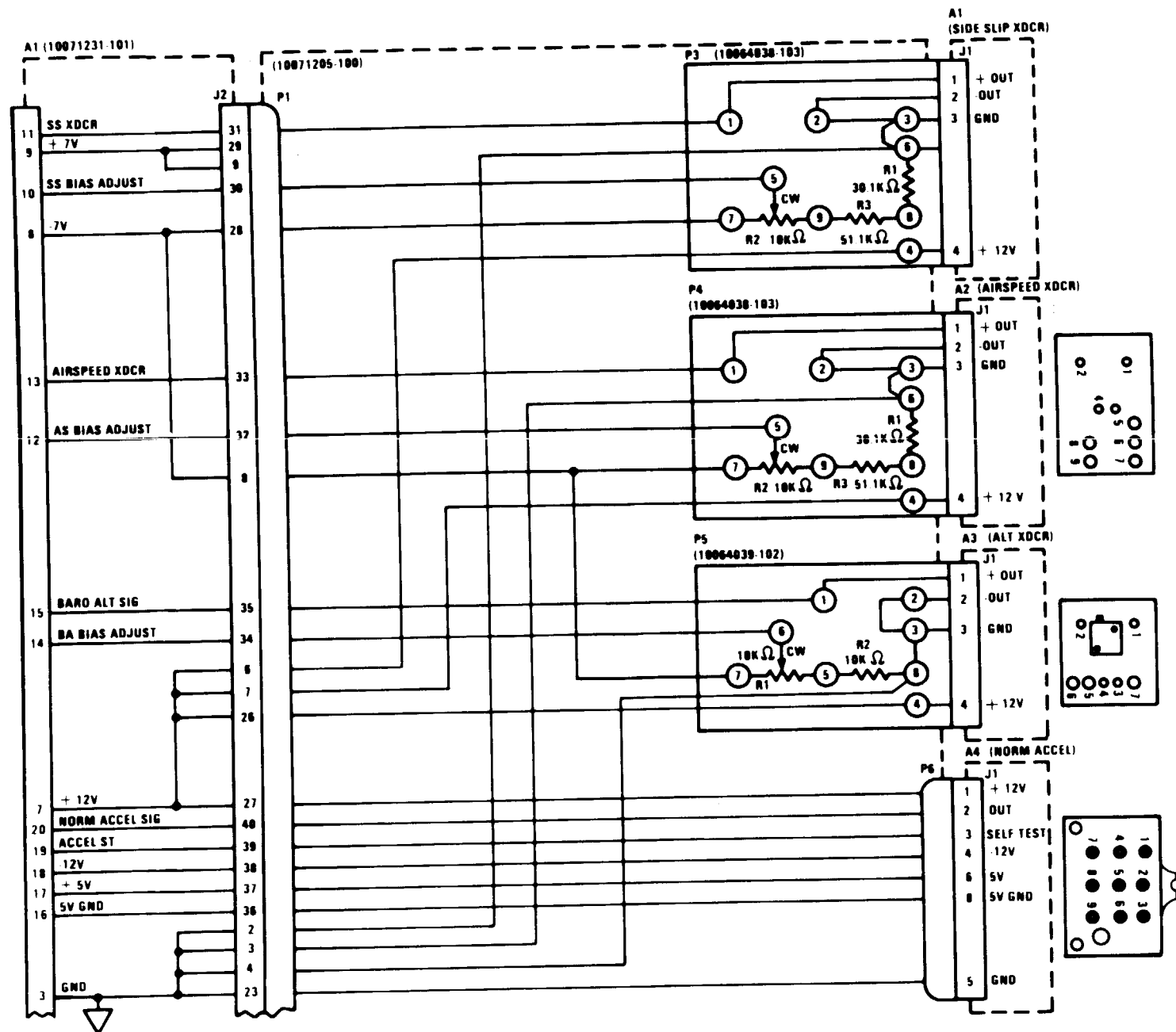

AFCS COMPUTER BASE WIRING DIAGRAM

30886

END OF TASK

11-5.2 AFCS COMPUTER VISUAL CHECK

INITIAL SETUP

Applicable Configurations:
All

Tools:
Electronic Repairer's Tool Kit,
NSN 5180-00-064-5178

Materials:
None

Personnel Required:
35M20 Avionic Navigation and Flight Control
Equipment Repairer.

References:
TM 55-1520-240-23

Equipment Condition:
TM 55-1520-240-23:
AFCS Computer Base Separated
From AFCS Computer Box

TASK	RESULT
1. Check components on base (1).	If any component is loose or damaged, tighten or replace it as required. If wiring to any component is damaged, replace it.
2. Check wiring on bottom of box (2).	If any wire is broken, forward computer to depot for disposition.

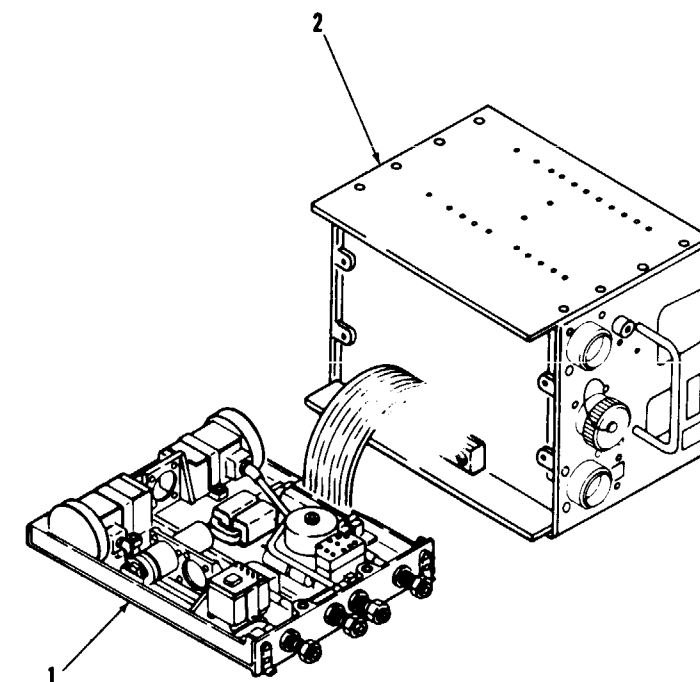

FOLLOW-ON MAINTENANCE:

TM 55-1520-240-23:
AFCS computer base connected to box.
Test AFCS computer.

11-5.3 AFCS COMPUTER FAILS TEST 1 (CONTINUITY TEST)

FAULT ISOLATION PROCEDURE

INITIAL SETUP

Applicable Configurations:

All

Tools:

None

Personnel Required:

35M20 Avionic Navigation and Flight Control
Equipment Repairer.

References:

TM 55-1520-240-23

Equipment Condition:

None

RETURN AFCS COMPUTER TO
DEPOT FOR DISPOSITION.

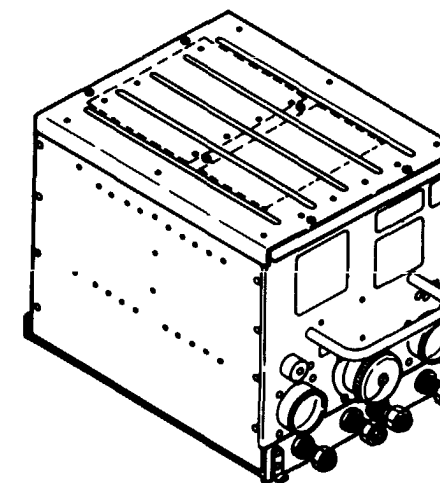

AFCS
COMPUTER

11-5.4 AFCS COMPUTER FAILS TEST 2 (POWER SUPPLY TEST)

FAULT ISOLATION PROCEDURE

INITIAL SETUP

Applicable Configurations:

All

Tools:

Electronic Repairer's Tool Kit,
NSN 5180-00-064-5178
Multimeter

Materials:

None

Personnel Required:

35M20 Avionic Navigation and Flight Control
Equipment Repairer.

References:

TM 55-1520-240-23

Equipment Condition:

Visual Check of AFCS Computer Performed
(Task 11-5.2)

TM 55-1520-240-23:

AFCS Computer Cover Removed

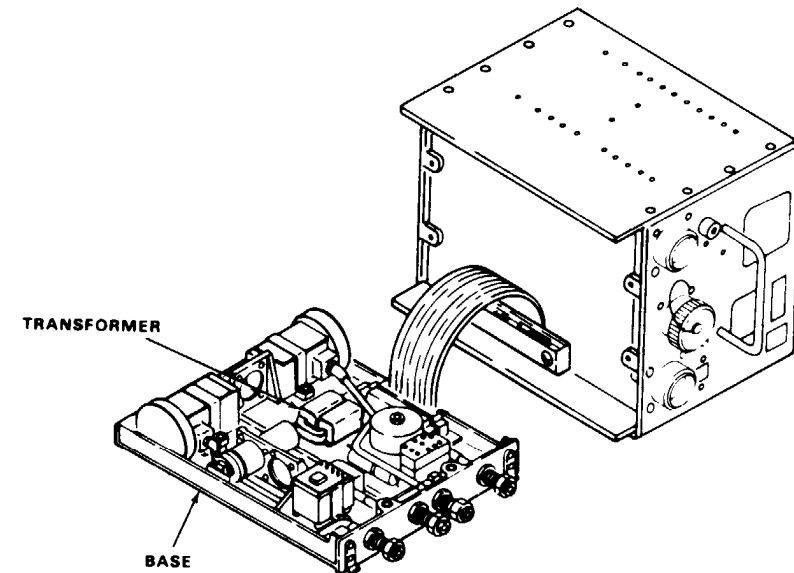
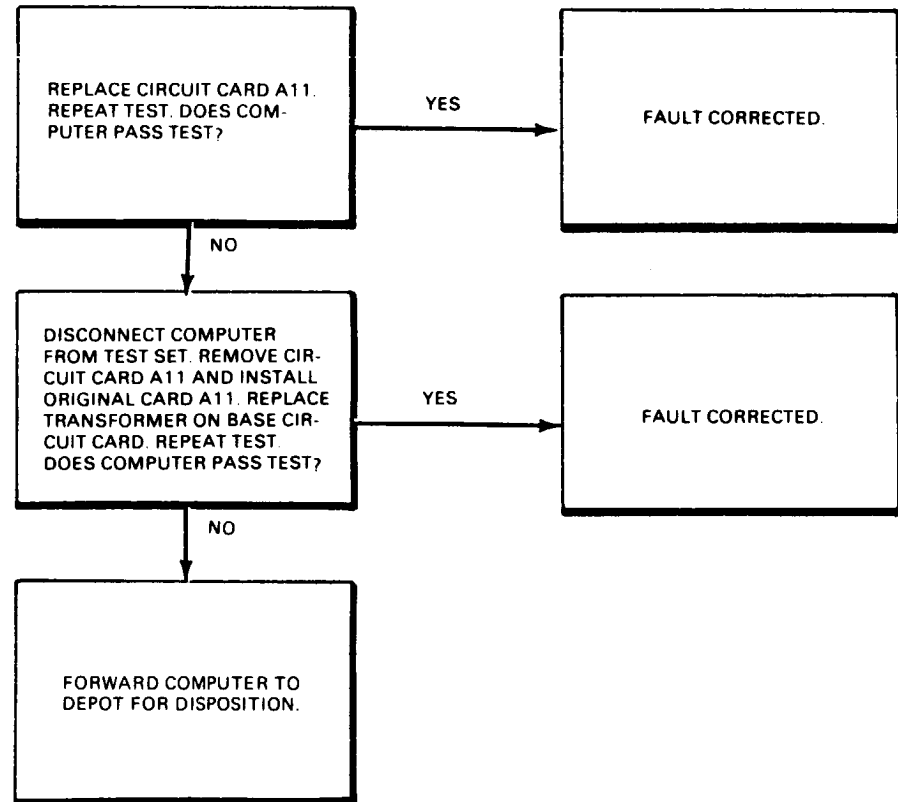
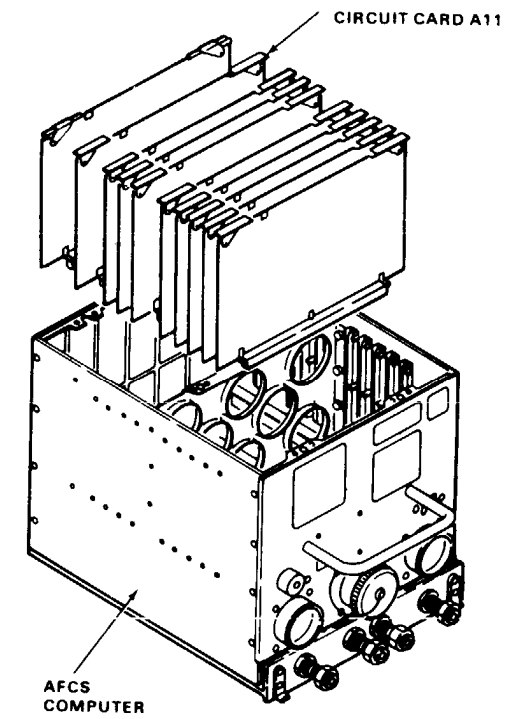

FAULT ISOLATION PROCEDURE

INITIAL SETUP

Applicable Configurations:

All

Tools:

Electronic Repairer's Tool Kit,
NSN 5180-00-064-5178

Materials:

None

Personnel Required:

35M20 Avionic Navigation and Flight Control
Equipment Repairer.

References:

TM 55-1520-240-23

Equipment Condition:

Visual Check of AFCS Computer Performed
(Task 11-5.2)
TM 55-1520-240-23
AFCS Computer Cover Removed

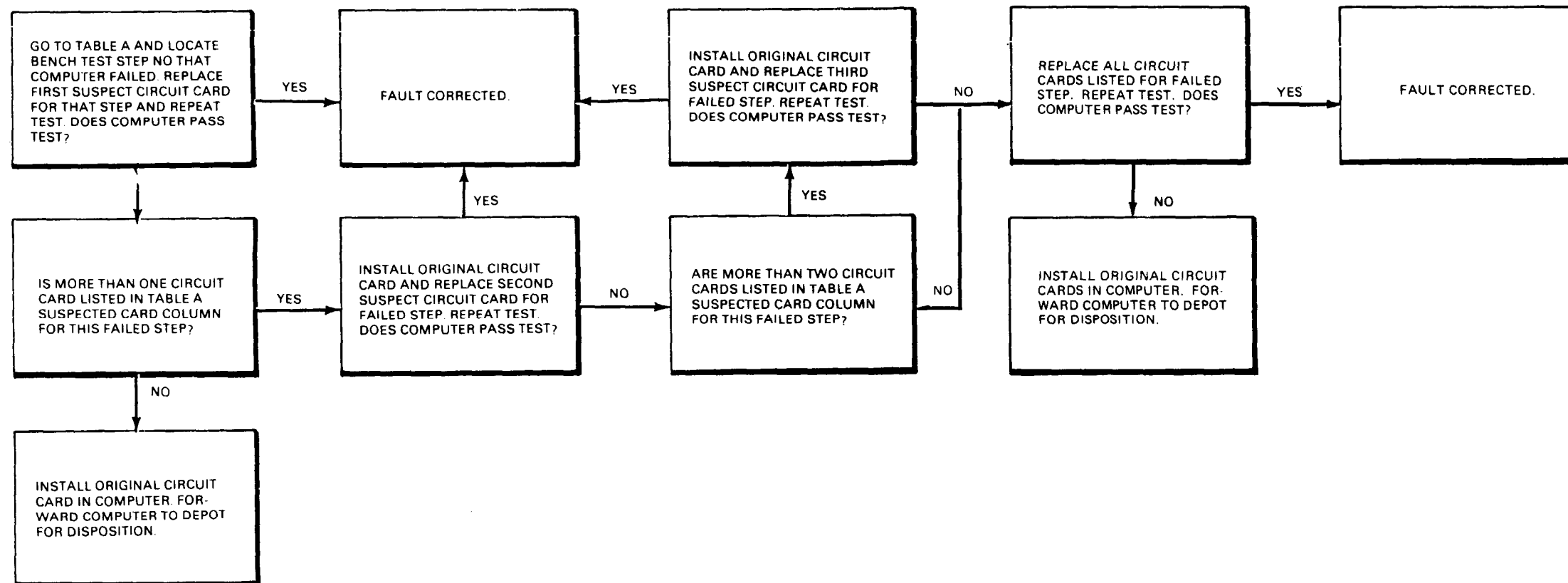
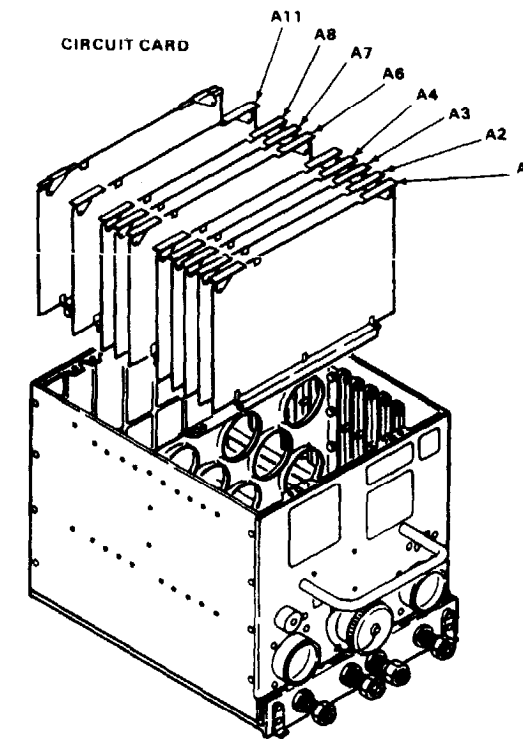

TABLE A. LOGIC TEST
FAULT ANALYSIS

BENCH TEST STEP NO.	SUSPECT CIRCUIT CARD
34	A12, A6, A1
36-38	A12, A1, A6
42-47	A1, A12
48-70	A1
73-80	A1, A2
83-85	A1, A4, A6
87	A1, A2
88-95	A1, A2, A6
102	A12, A7, A1
105-108	A1



FAULT ISOLATION PROCEDURE

INITIAL SETUP

Applicable Configurations:

All

Tools:

Electronic Repairer's Tool Kit,
NSN 5180-00-064-5178

Materials:

None

Personnel Required:

35M20 Avionic Navigation and Flight Control
Equipment Repairer.

References:

TM 55-1520-240-23

Equipment Condition:

Visual Check of AFCS Computer Performed
(Task 11-5.2)

TM 55-1520-240-23:

AFCS Computer Cover Removed

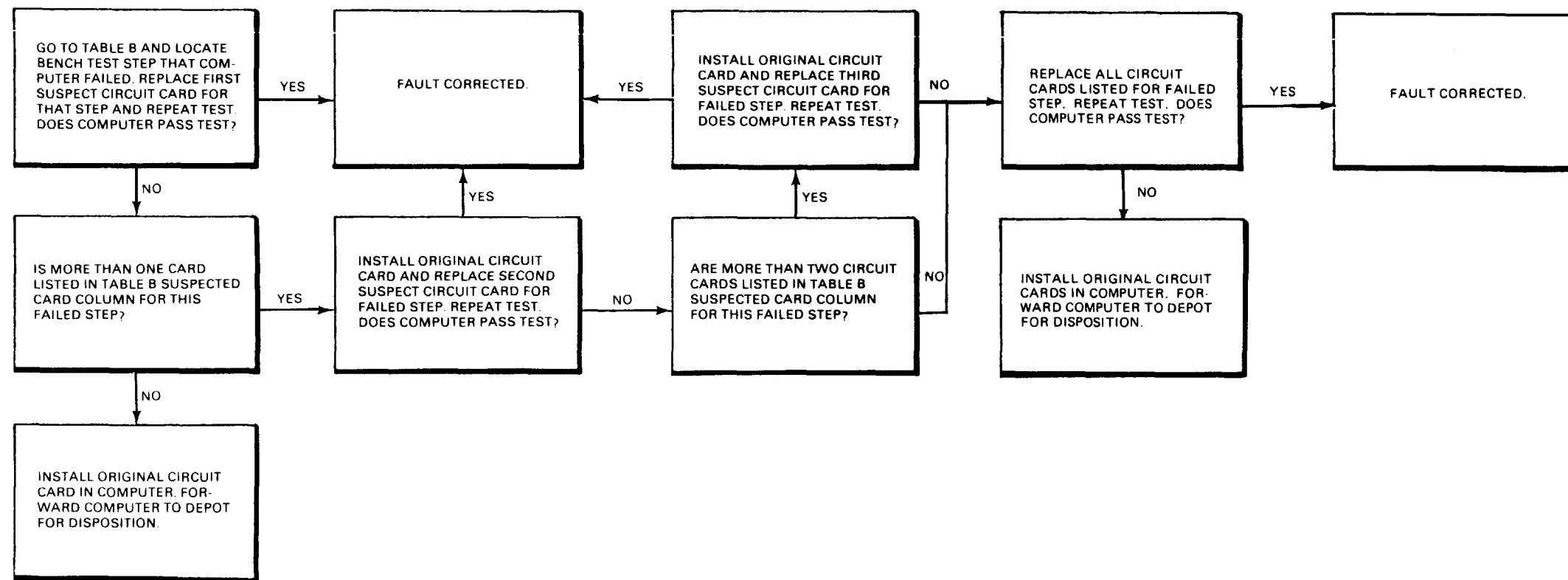

GO TO NEXT PAGE

TABLE B. PITCH AXIS TEST
FAULT ANALYSIS

BENCH TEST STEP NO.	SUSPECT CIRCUIT CARD
113-137	A3
145	A3, A4, A2
147	A1
157-162	A3

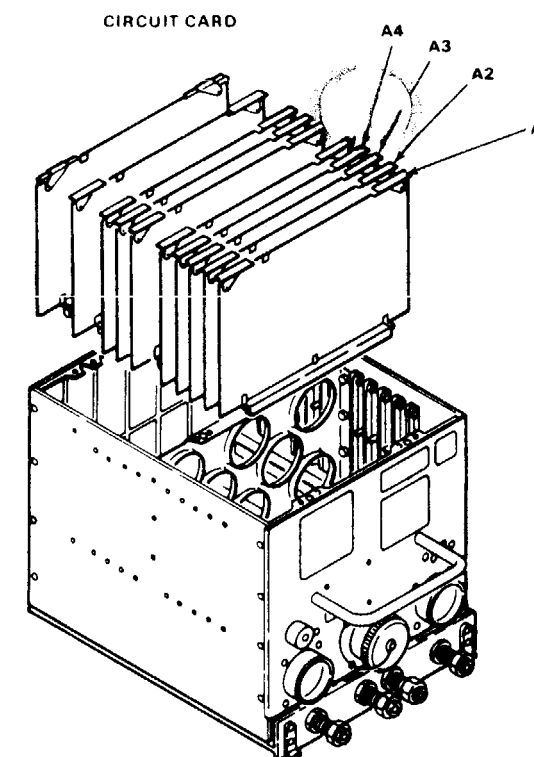

11-5.7 AFCS COMPUTER FAILS TEST 5 (ROLL AXIS TEST)

FAULT ISOLATION PROCEDURE

INITIAL SETUP

Applicable Configurations:

All

Tools:

Electronic Repairer's Tool Kit,
NSN 5180-00-064-5178

Materials:

None

Personnel Required:

35M20 Avionic Navigation and Flight Control
Equipment Repairer.

References:

TM 55-1520-240-23

Equipment Condition:

Visual Check of AFCS Computer Performed
(Task 11-5.2)

TM 55-1520-240-23

AFCS Computer Cover Removed

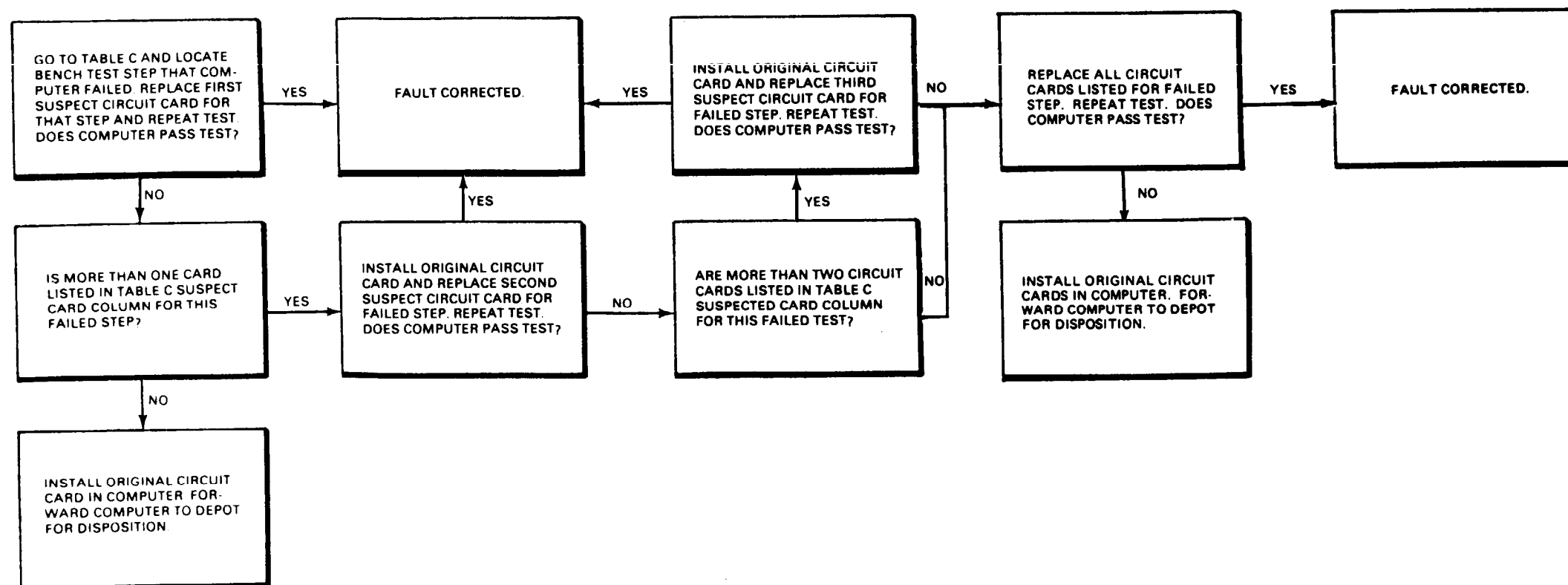

GO TO NEXT PAGE

TABLE C. ROLL AXIS TEST
FAULT ANALYSIS

BENCH TEST STEP NO.	SUSPECT CIRCUIT CARD
177-209	A2
216-219	A1, A2, A7
223-226	A1, A2
228-232	A2
234-236	A1, A2
243-247	A2
267-275	A7, A1
283	A7, A2
284-347	A2

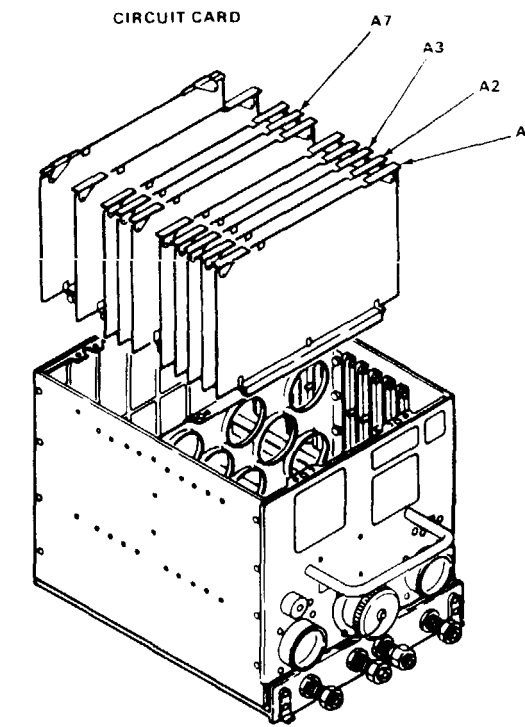

FAULT ISOLATION PROCEDURE

INITIAL SETUP

Applicable Configurations:

All

Tools:

Electronic Repairer's Tool Kit,
NSN 5180-00-064-5178

Materials:

None

Personnel Required:

35M20 Avionic Navigation and Flight Control
Equipment Repairer.

References:

TM 55-1520-240-23

Equipment Condition:

Visual Check of AFCS Computer Performed
(Task 11-5.2)

TM 55-1520-240-23:

AFCS Computer Cover Removed

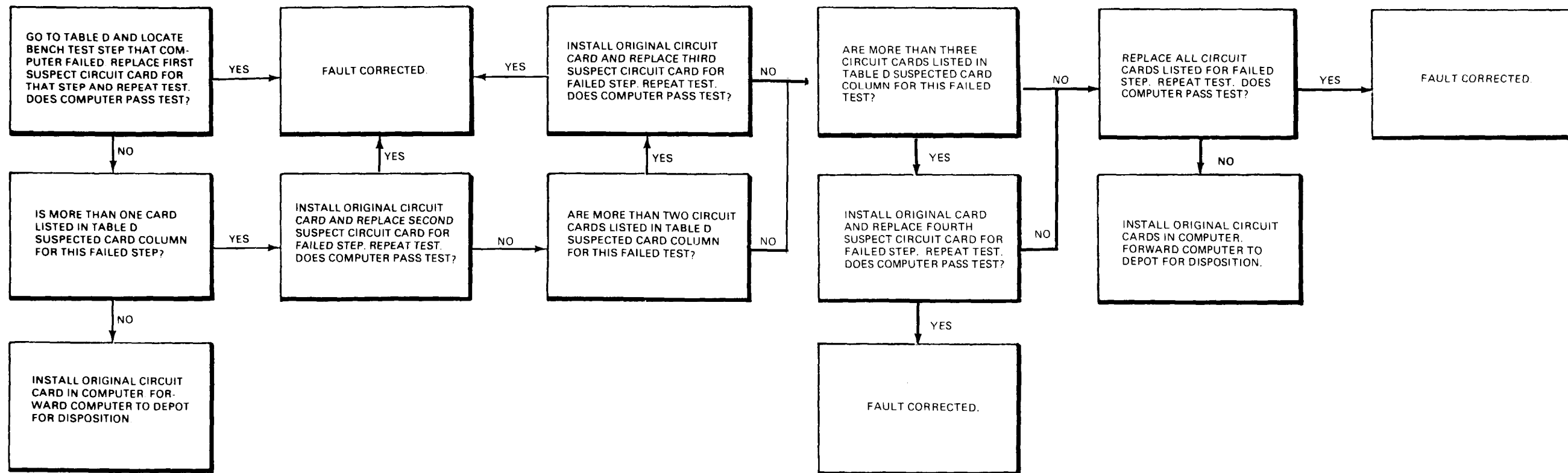
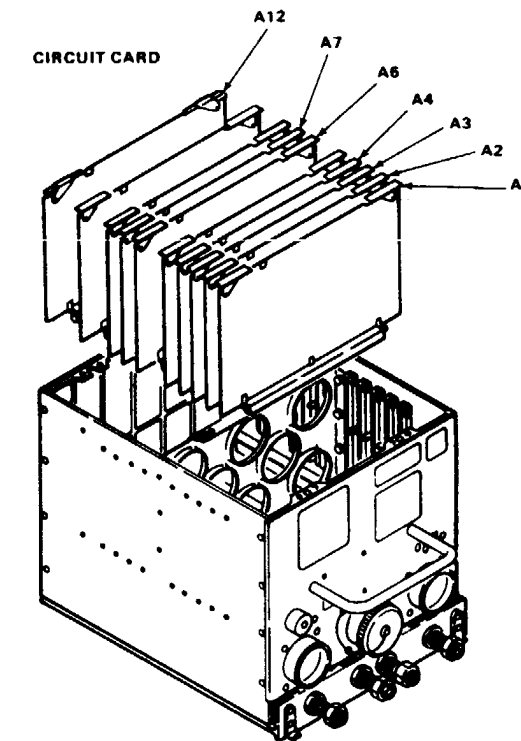

TABLE D. YAW AXIS TEST
FAULT ANALYSIS

BENCH TEST STEP NO.	SUSPECT CIRCUIT CARD
352	A4, A14, A6
360	A4, A8
366-370	A4
378	A6, A8
390	A4, A7
398	A4, A2
404-407	A6, A1, A4
410-415	A4, A1
419-420	A4, A7
433	A4
435-445	A4, A8, A6
458-464	A4



11-5.9 AFCS COMPUTER FAILS TEST 7 (DASH TEST)

FAULT ISOLATION PROCEDURE

INITIAL SETUP

Applicable Configurations:

All

Tools:

Electronic Repairer's Tool Kit,
NSN 5180-00-064-5178

Materials:

None

Personnel Required:

35M20 Avionic Navigation and Flight Control
Equipment Repairer.

References:

TM 55-1520-240-23

Equipment Condition:

Visual Check of AFCS Computer Performed
(Task 11-5.2)
TM 55-1520-240-23:
AFCS Computer Cover Removed

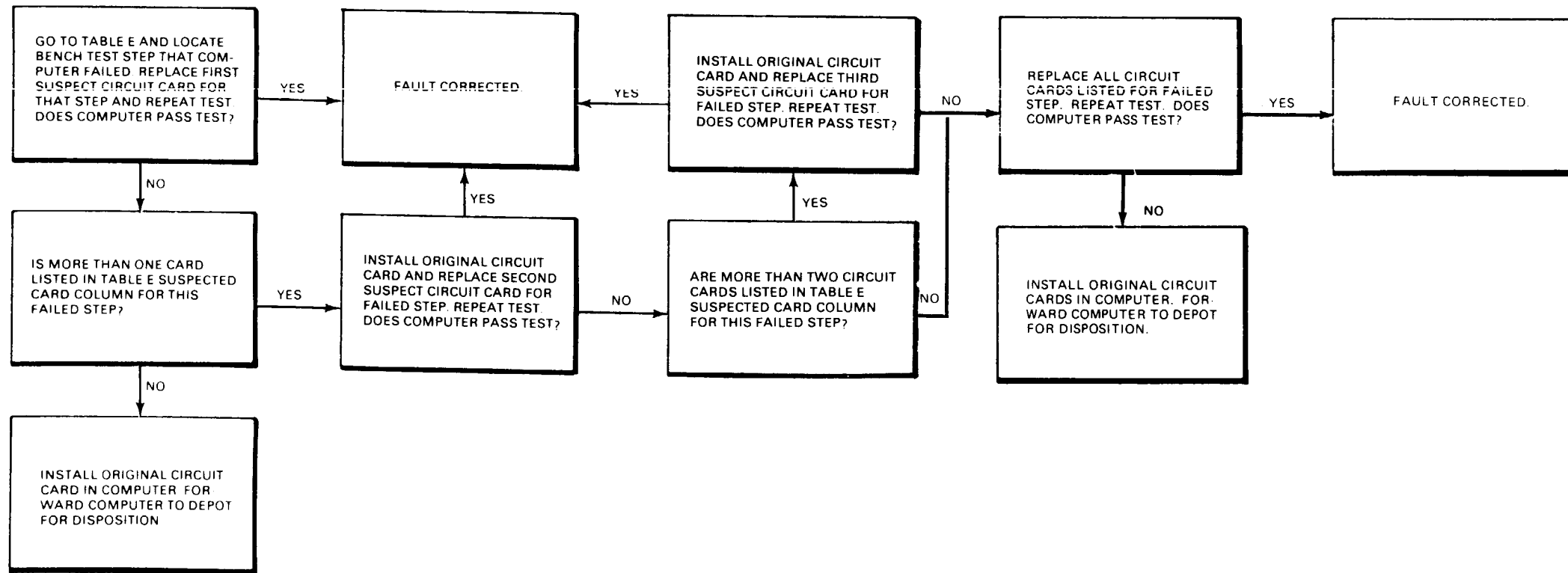

GO TO NEXT PAGE

TABLE E. DASH TEST
FAULT ANALYSIS

BENCH TEST STEP NO.	SUSPECT CIRCUIT CARD
474	A6
490	A3
491	A3, A12
498, 503	A1, A6
500-506	A6, A3
511-524	A3
531	A1, A3
535-543	A3
551-570	A6, A12

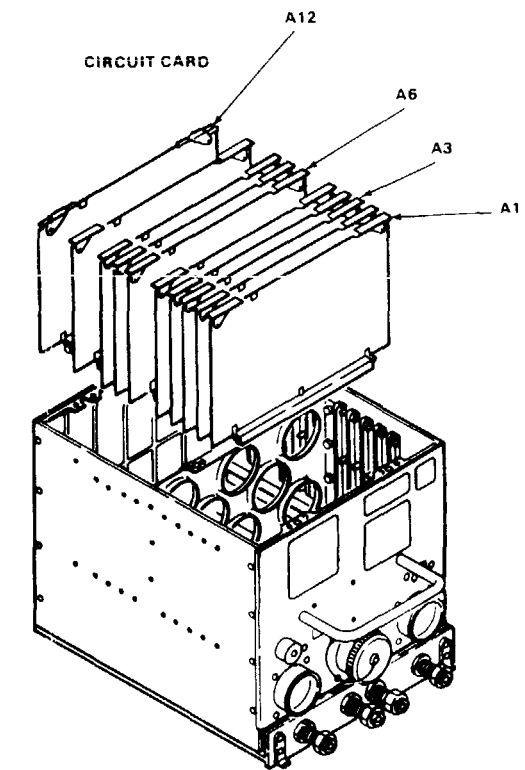

FAULT ISOLATION PROCEDURE

INITIAL SETUP

Applicable Configurations:

All

Tools:

Electronic Repairer's Tool Kit,
NSN 5180-00-064-5178

Materials:

None

Personnel Required:

35M20 Avionic Navigation and Flight Control
Equipment Repairer.

References:

TM 1520-240-23

Equipment Condition:

Visual Check of AFCS Computer Performed
(Task 11-5.2)

TM 55-1520-240-23:

AFCS Computer Cover Removed

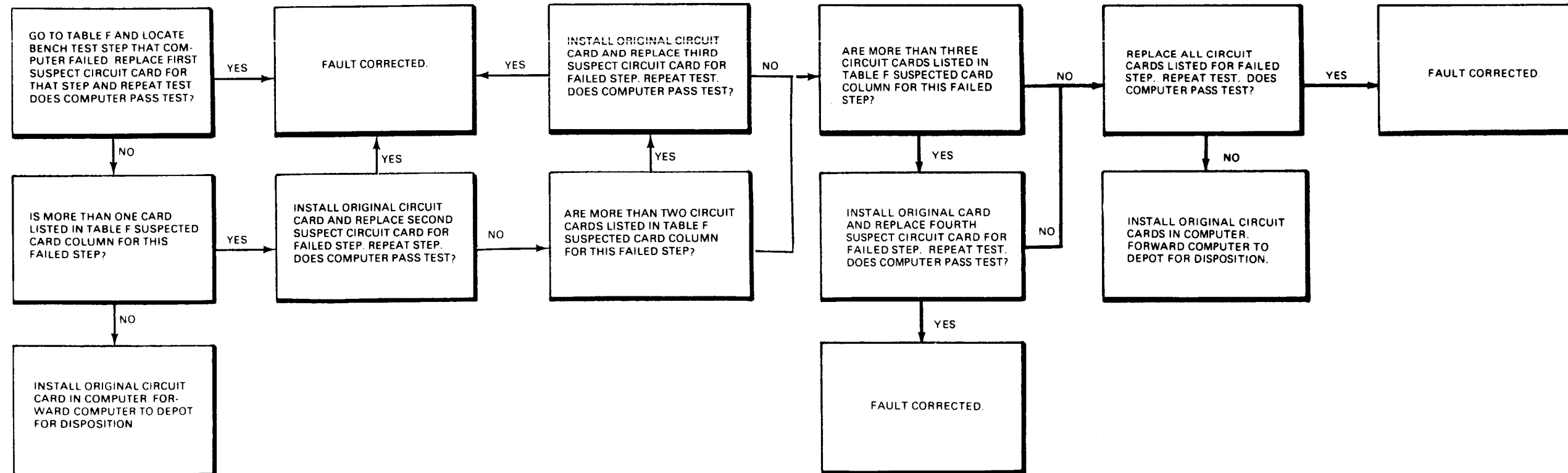
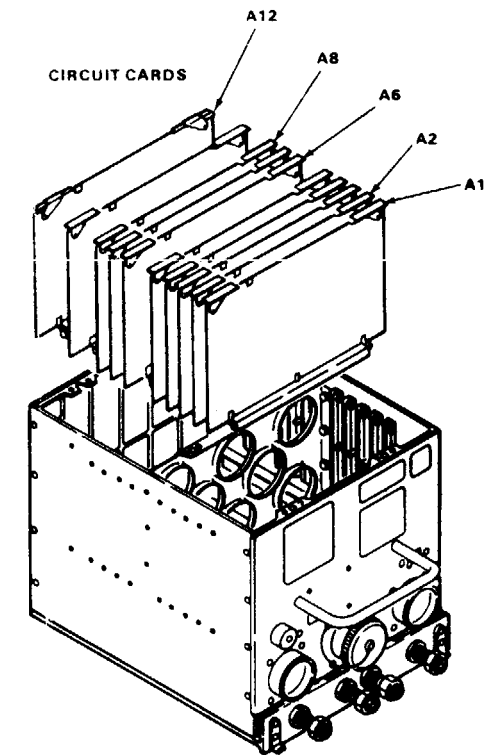

TABLE F. LCT TEST
FAULT ANALYSIS

BENCH TEST STEP NO.	SUSPECT CIRCUIT CARD
582	A8, A12, A6, A3
584-592	A8
594	A12
600-602	A8



45 x 54

D145-12454-SPA

FAULT ISOLATION PROCEDURE

INITIAL SETUP

Applicable Configurations:

All

Tools:

Electronic Repairer's Tool Kit,
NSN 5180-00-064-5178

Materials:

None

Personnel Required:

35M20 Avionic Navigation and Flight Control
Equipment Repairer.

References:

TM 55-1520-240-23

Equipment Condition:

Visual Check of AFCS Computer Peformed
(Task 11-5.2)

TM 55-1520-240-23:

AFCS Computer Cover Removed

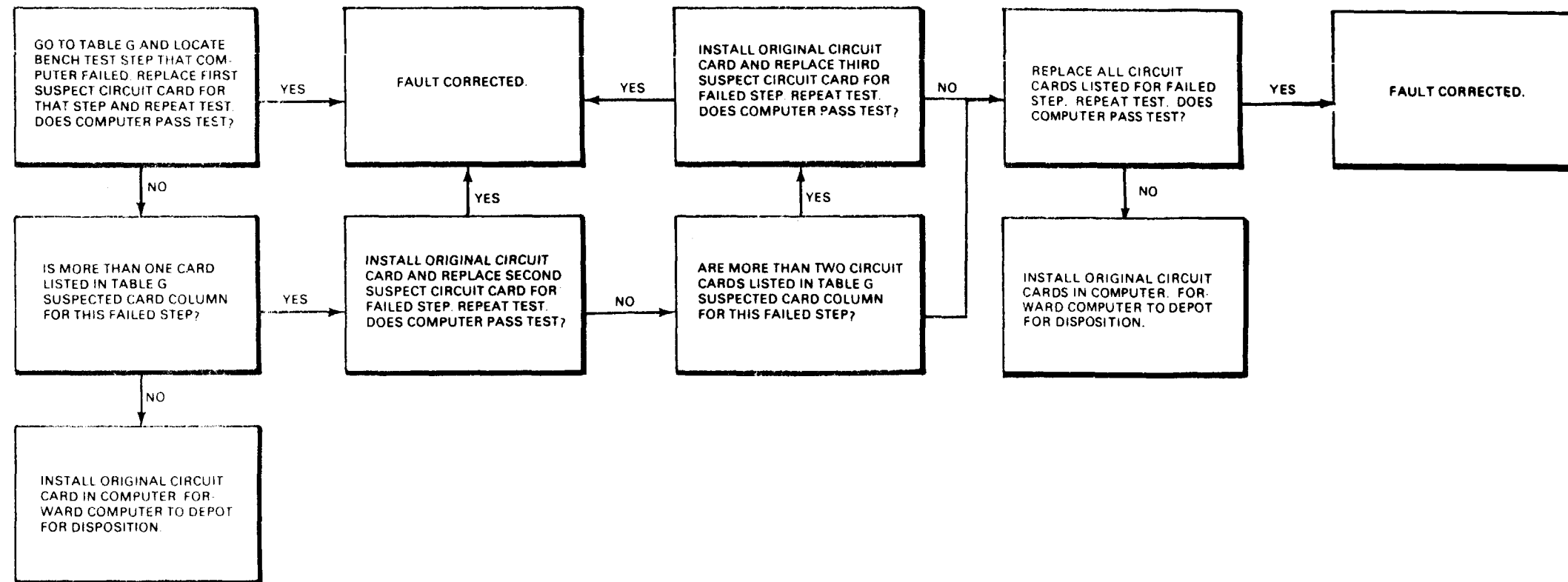
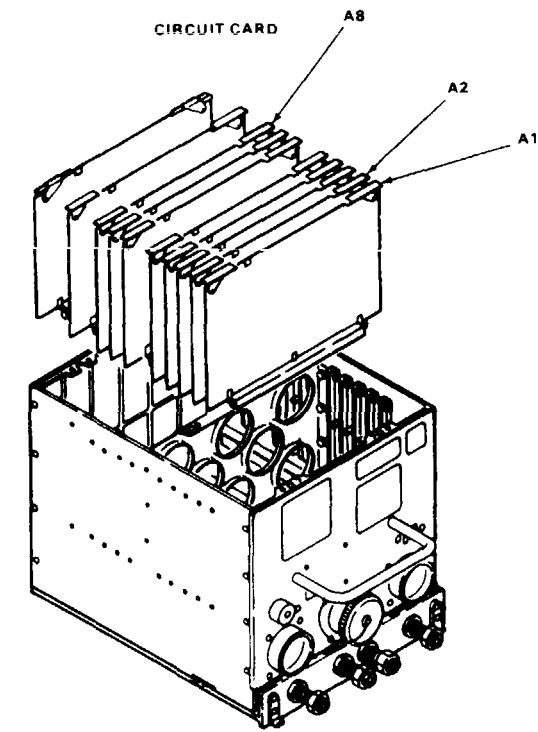

TABLE G. CCDA TEST
FAULT ANALYSIS

BENCH TEST STEP NO.	SUSPECT CIRCUIT CARD
618-630	A8, A2
641-693	A8, A7



FAULT ISOLATION PROCEDURE

INITIAL SETUP

Applicable Configurations:

All

Tools:

Electronic Repairer's Tool Kit,
NSN 5180-00-064-5178
Multimeter

Materials:

None

Personnel Required:

Avionic Navigation and Flight Control
Equipment Repairer.

References:

TM 55-1520-240-23

Equipment Condition:

Visual Check of AFCS Computer Performed
(Task 11-5.2)
TM 55-1520-240-23

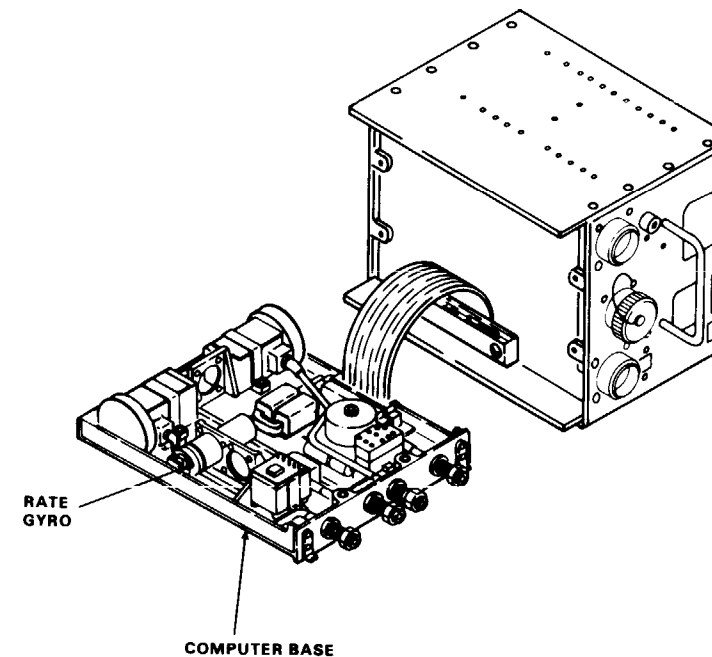
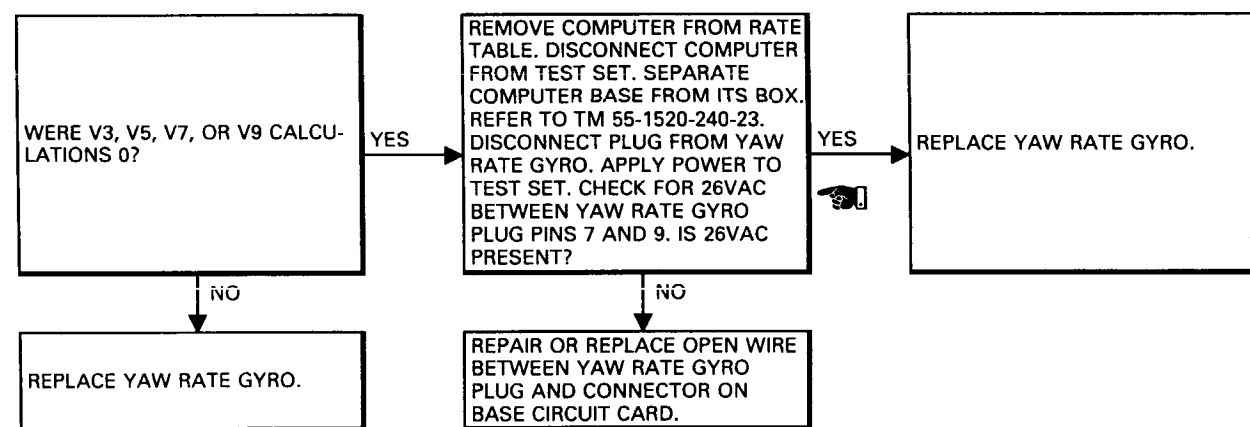

D145-12455-SPA

11-5.13 AFCS COMPUTER FAILS TEST 11 (NORMAL ACCELERATION TEST)

FAULT ISOLATION PROCEDURE

INITIAL SETUP

Applicable Configurations:

All

Tools:

Electronic Repairer's Tool Kit,
NSN 5180-00-064-5178
Multimeter

Personnel Required:

35M20 Avionic Navigation and Flight Control
Equipment Repairer.

References:

TM 55-1520-240-23

Equipment Condition:

Visual Check of AFCS Computer Performed
(Task 11-5.2)

Materials:

None

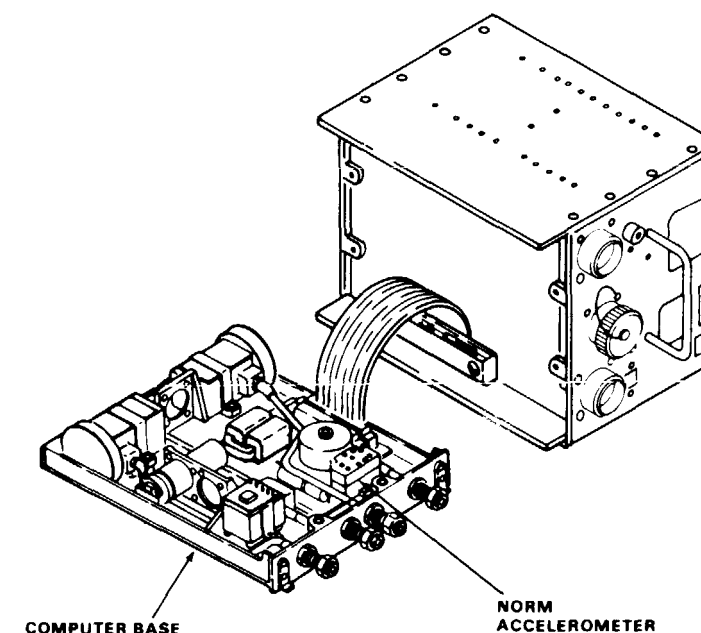
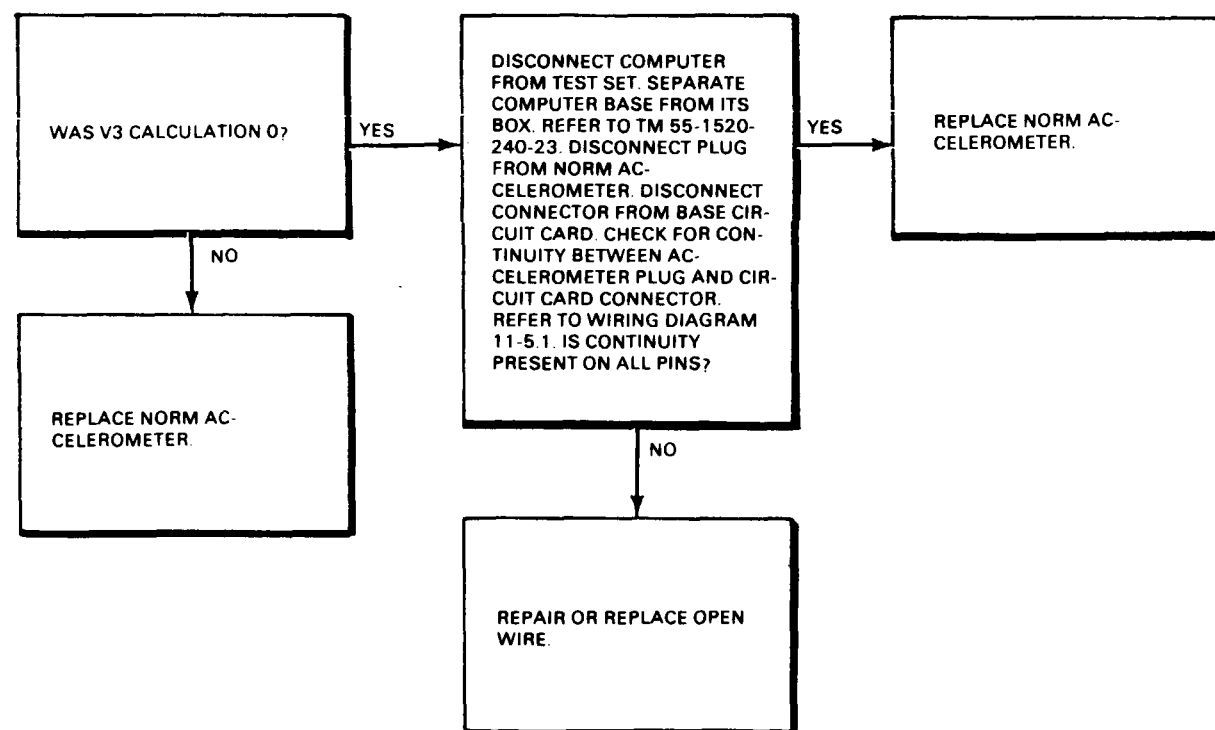

11-5.14 AFCS COMPUTER FAILS TEST 12 (PRESSURE TRANSDUCERS TEST)

FAULT ISOLATION PROCEDURE
INITIAL SETUP

Personnel Required:
35M20 Avionic Navigation and Flight Control
Equipment Repairer.

Applicable Configurations:
All

References:
TM 55-1520-240-23

Tools:
Electronic Repairer's Tool Kit,
NSN 5180-00-064-5178
Multimeter

Equipment Condition:
Visual Check of AFCS Computer Performed
(Task 11-5.2)

Materials:
None

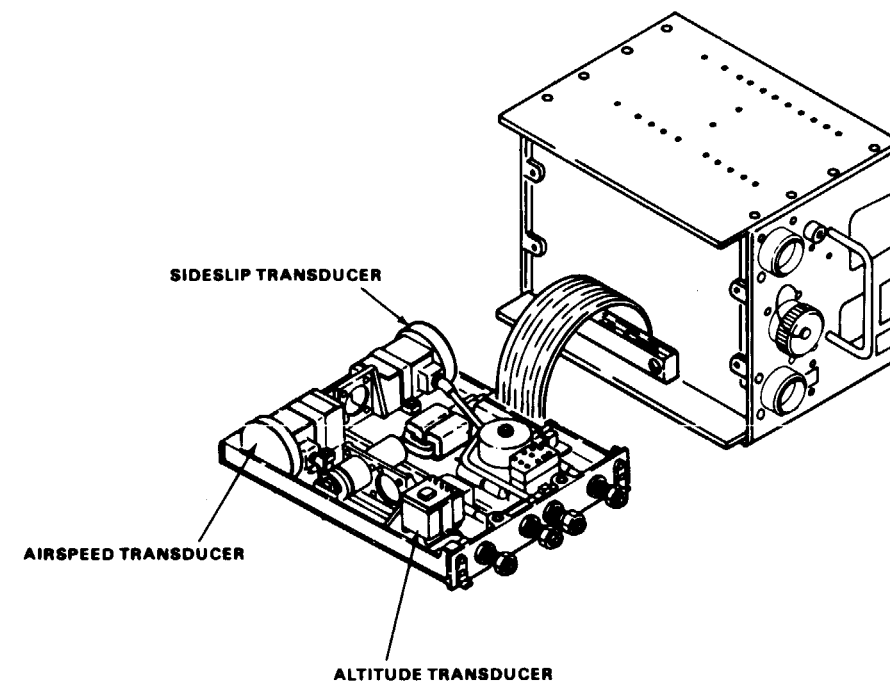

11-5.14 AFCS COMPUTER FAILS TEST 12 (PRESSURE TRANSDUCERS TEST) (Continued)

11-5.14

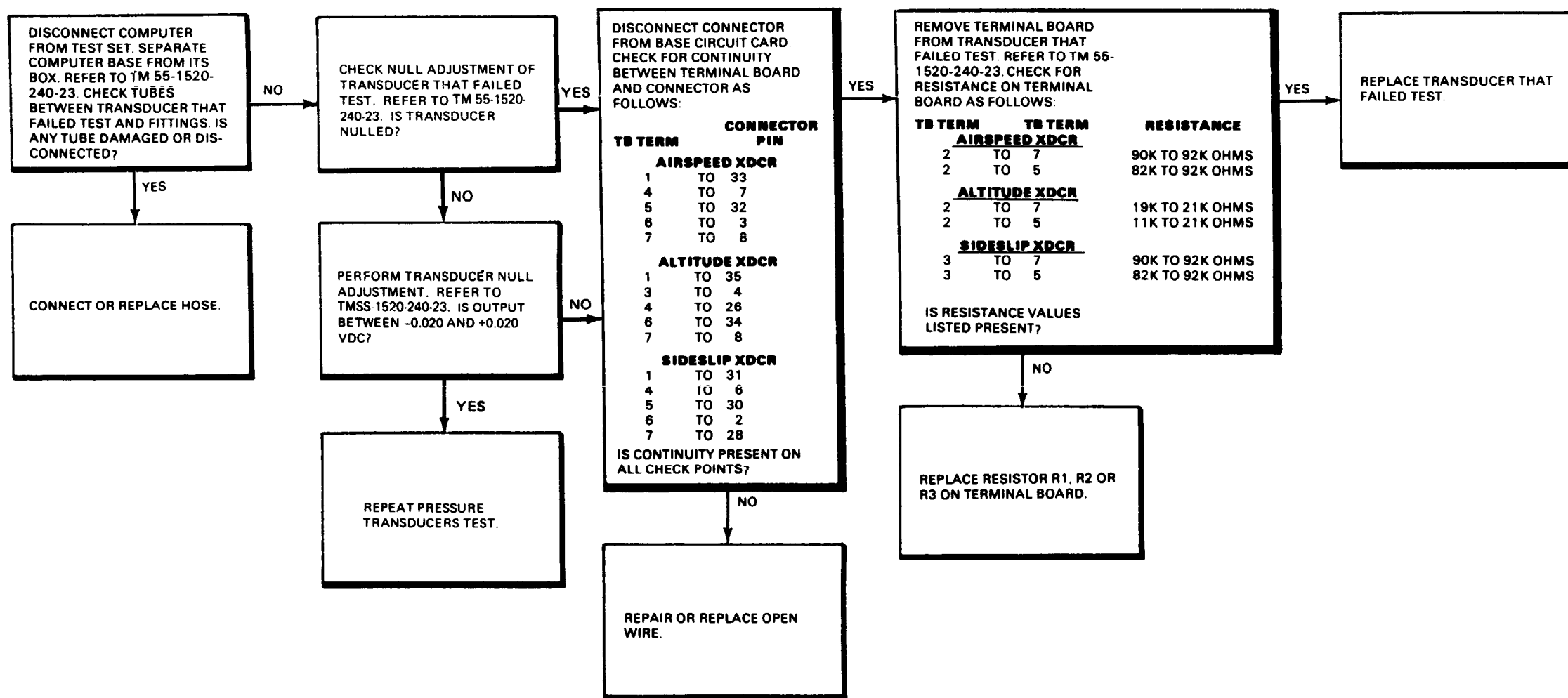

END OF TASK

FAULT ISOLATION PROCEDURE

INITIAL SETUP

Personnel Required:

35M20 Avionic Navigation and Flight Control Equipment Repairer.

Applicable Configurations:

All

References:

TM 55-1520-240-23

Tools:

Electronic Repairer's Tool Kit,
NSN 5180-00-064-5178

Equipment Condition:

Visual Check of AFCS Computer Performed
(Task 11 -5.2)

Materials:

None

TM 55-1520-240-23:

AFCS Computer Cover Required

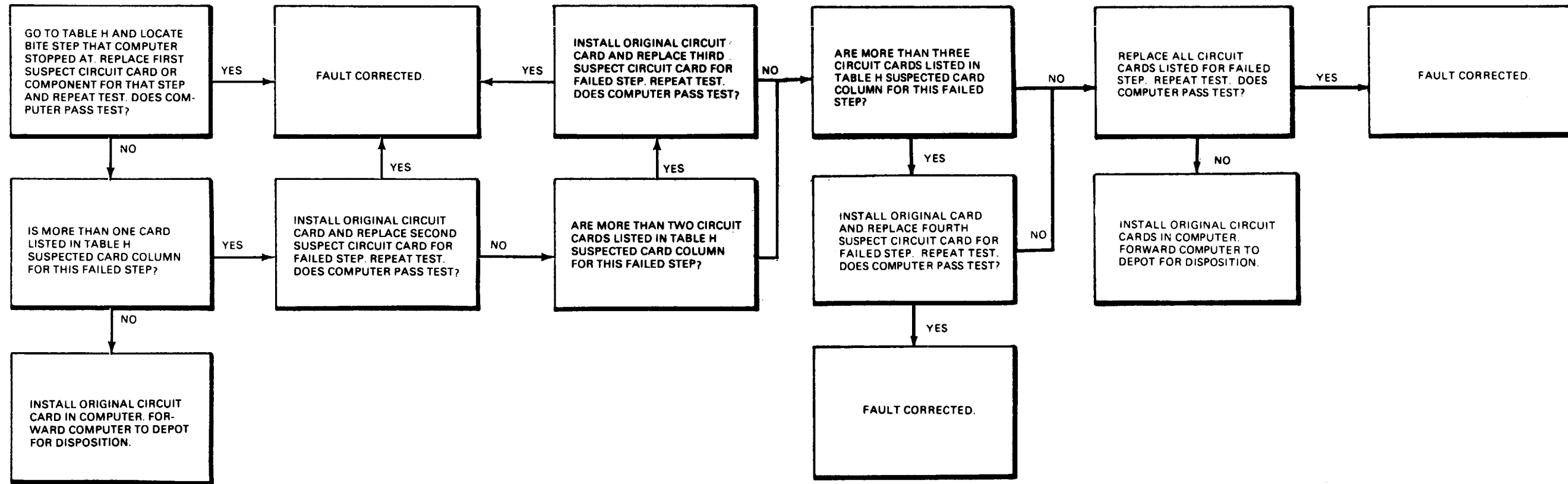

GO TO NEXT PAGE

TABLE H. BITE TEST
FAULT ANALYSIS

BITE STEP NO.	CIRCUIT CARD OR SUSPECT COMPONENT
0-3	A5, A6, A11
4,5	A3
6	A8, A12, /43, A6
7, 6	A3, A2, A4
9	A8, A12, A3, A6
11-16	A2, A1
17	A4, A2
18	A8, A12
19-25	A3, A12, A6, A1
26-31	A8, A1, A12
32-44	A4, A8, A1, A7, A6, A14
45-52	A2, A7, A1
54	A8, A14, A2
56,57	A4, A1, A14
70,73	A3
75,76	A4
80,81	A2
85,86	A12
87	A8
89	A3
91	A4
93	A2
95	A8, A1

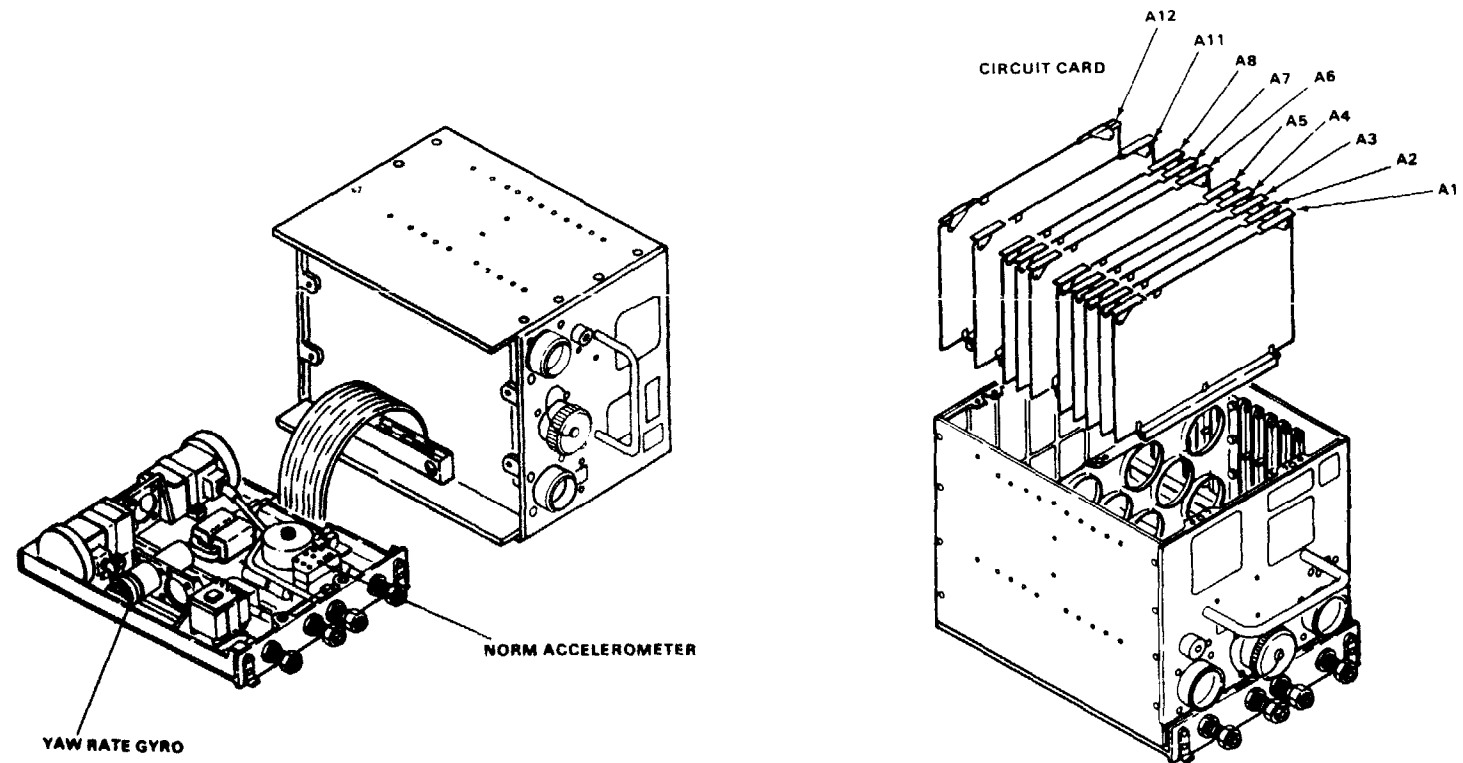

D145-12459-SPA

11-6 COCKPIT CONTROL DRIVE
ACTUATOR (CCDA)

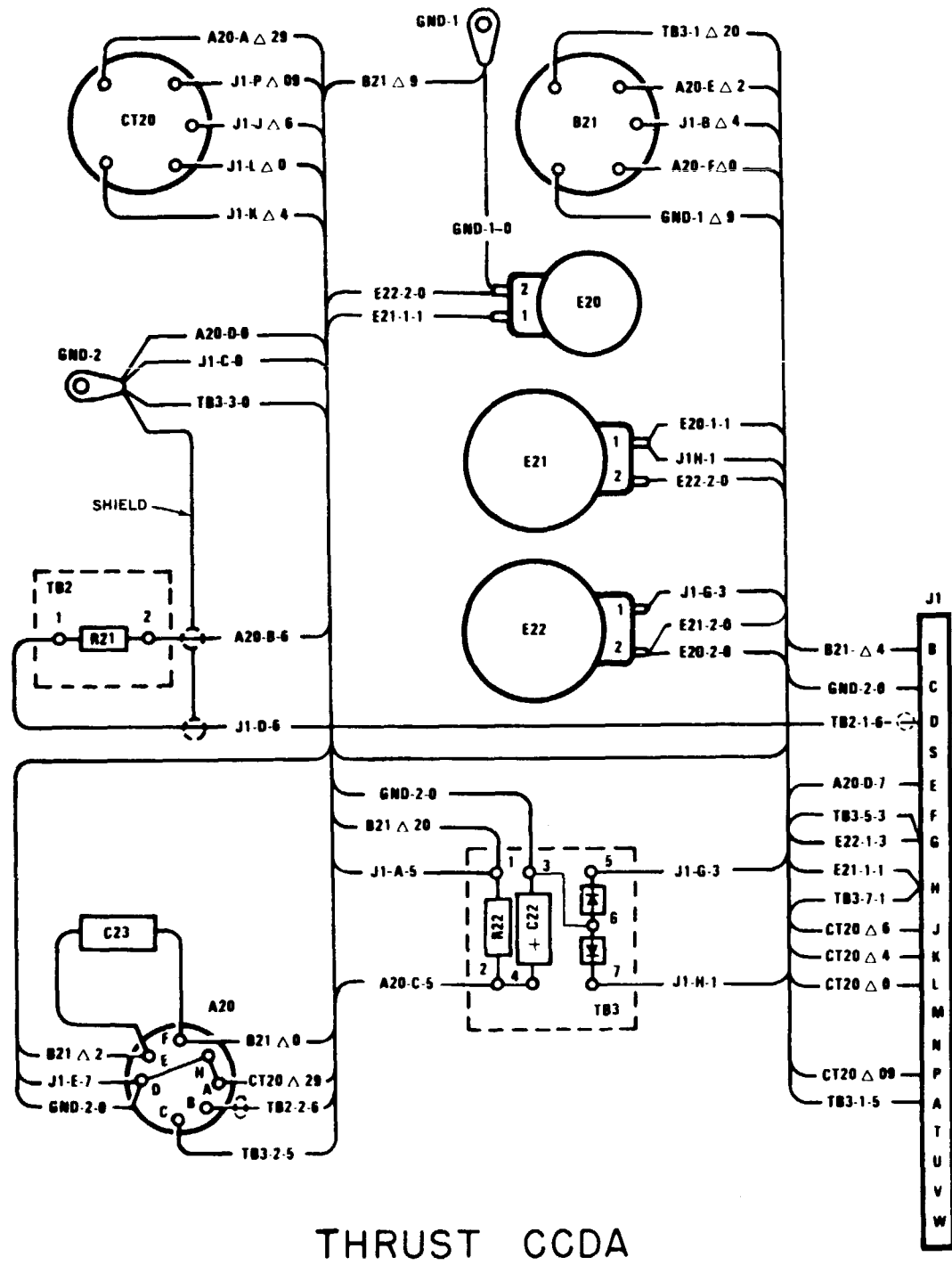

NOTES:

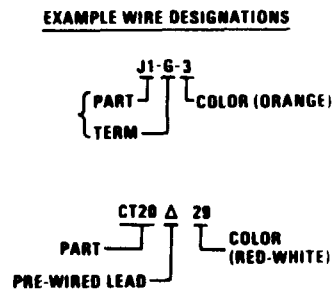

EIA COLOR CODE

- | | |
|------------|------------|
| 0 - BLACK | 5 - GREEN |
| 1 - BROWN | 6 - BLUE |
| 2 - RED | 7 - VIOLET |
| 3 - ORANGE | 8 - GREY |
| 4 - YELLOW | 9 - WHITE |

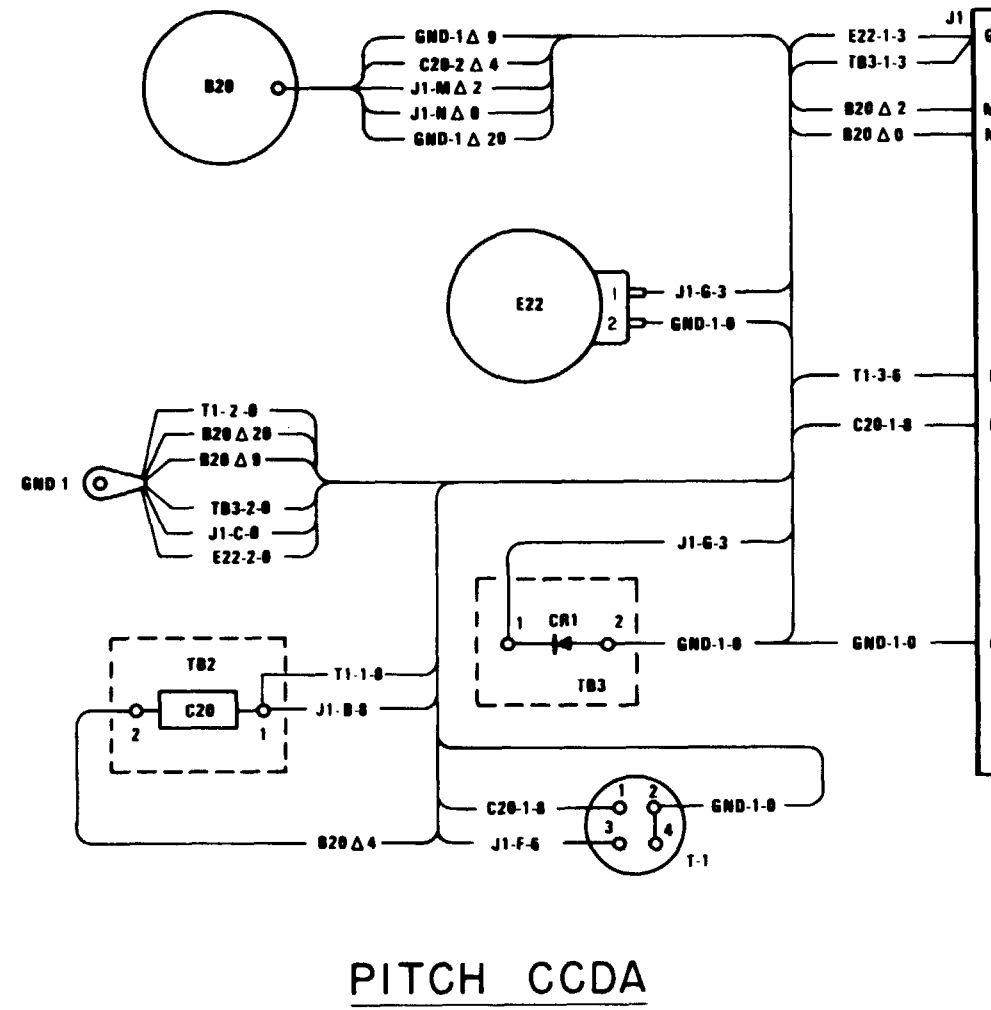

11-6.2 COCKPIT CONTROL DRIVE ACTUATOR (CCDA)
VISUAL CHECK

INITIAL SETUP

Applicable Configurations:
All

Tools:
Electronic Repairer's Tool Kit,
NSN 5180-00-064-5178

Materials:
None

Personnel Required:
35M20 Avionic Navigation and Flight Control
Equipment Repairer.

References:
TM 55-1520-240-23

Equipment Condition:
TM 55-1520-240-23
CCDA Cover Removed.

TASK	RESULT
1. Check pins in receptacle (1).	If any pin is bent, straighten it. If any pin is burnt, broken, or corroded, replace receptacle (1).
2. Check parts mounted on inside of actuator (2).	If any part is loose, tighten it. If any part is burnt or damaged, replace it.

FOLLOW-ON MAINTENANCE

TM 55-1520-240-23:
CCDA Cover Installed
Test Pitch or Thrust Cockpit Control
Drive Actuator (CCDA)

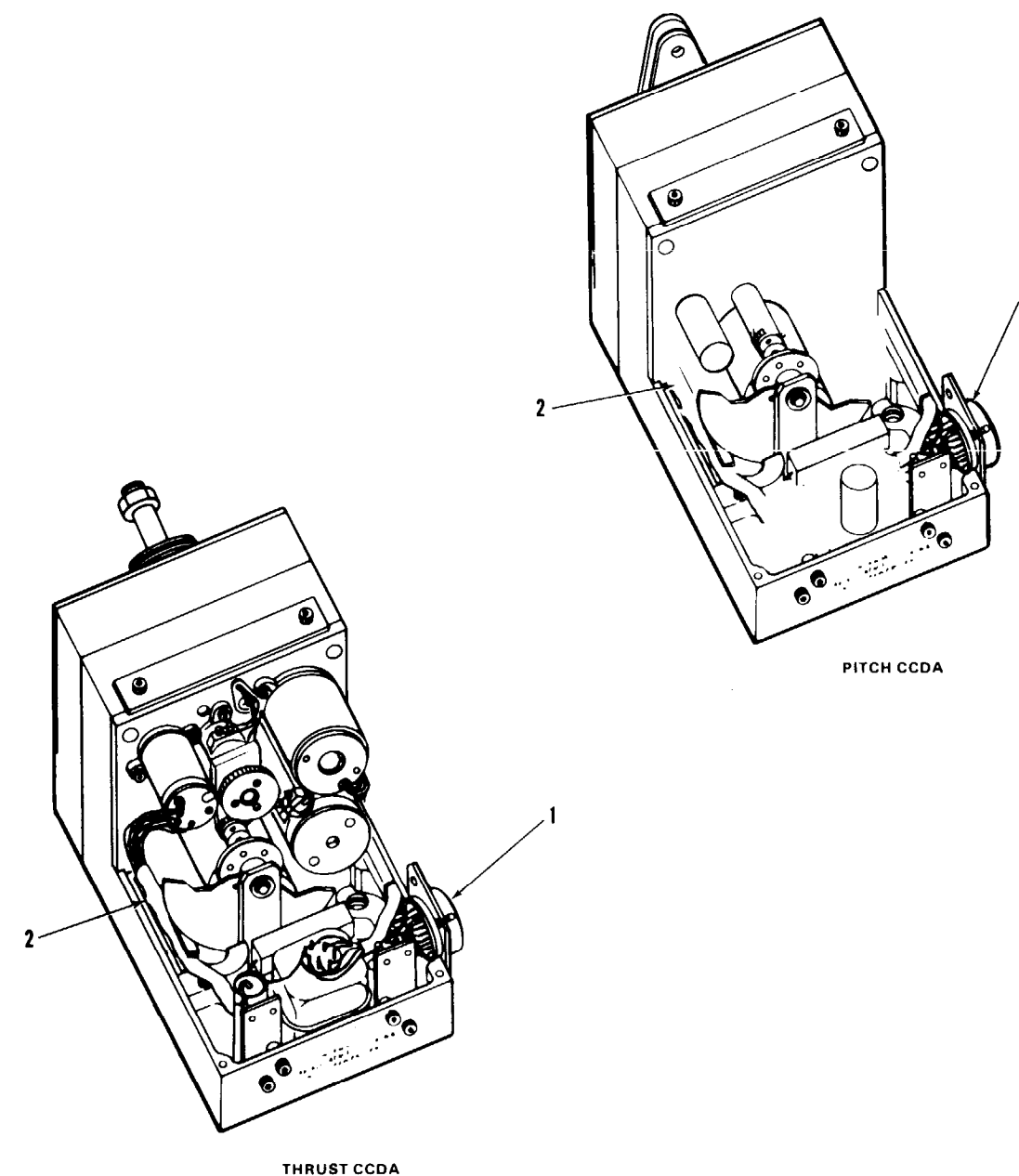

FAULT ISOLATION PROCEDURE

INITIAL SETUP

Applicable Configurations:

All

Tools:

Electronic Repairer's Tool Kit,
NSN 5180-00-064-5178
Multimeter

Materials:

None

Personnel Required:

Avionic Navigation and Flight Control
Equipment Repairer.

Reference:

TM 55-1520-240-23

Equipment Condition:

Visual Check of CCDA Performed (Task 11-6.2)

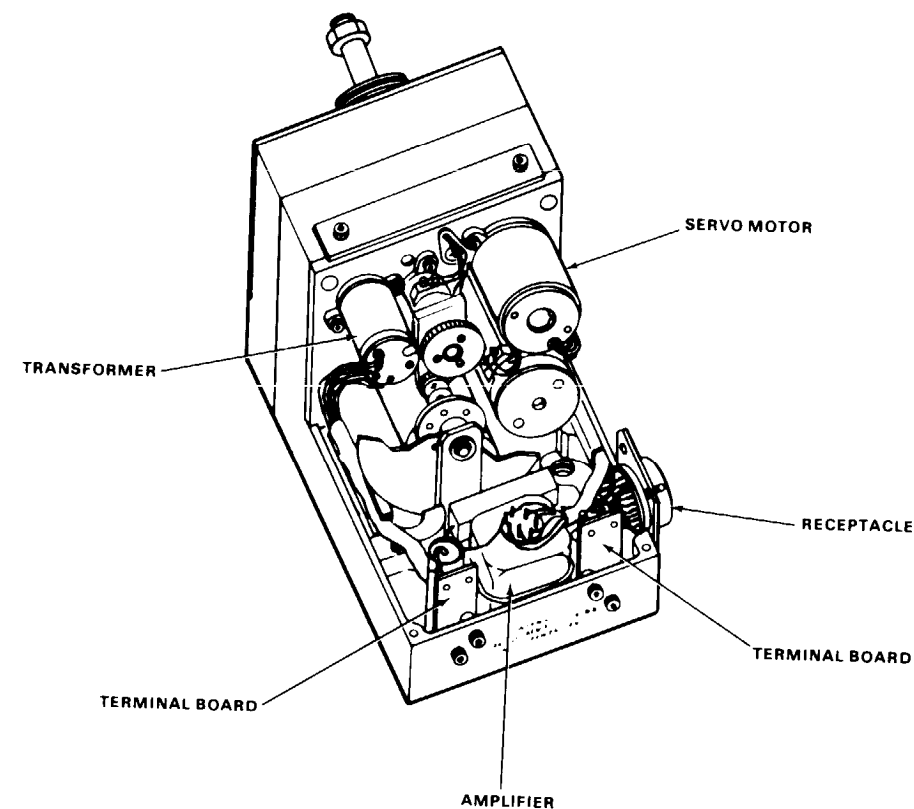
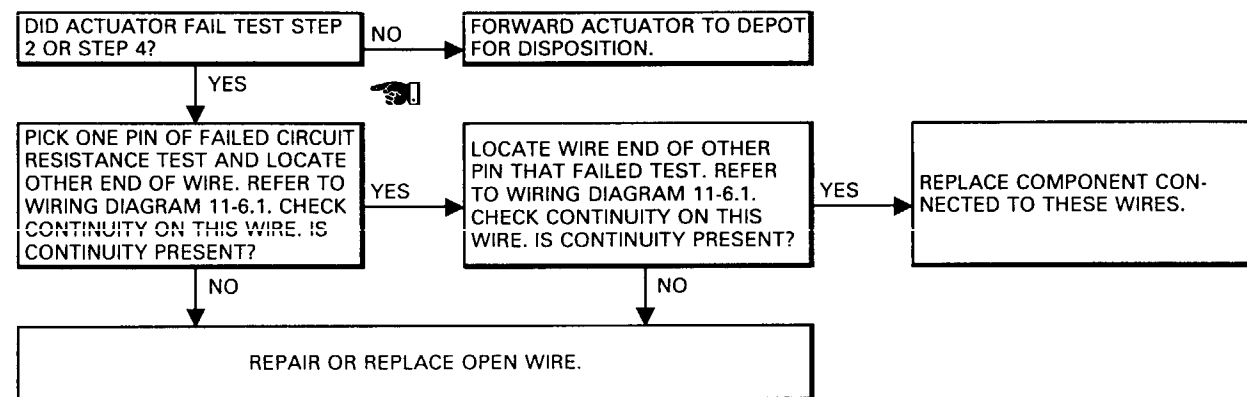

D145-12472-SPA

11-6.4 THRUST COCKPIT CONTROL DRIVE ACTUATOR FAILS
BRAKE FUNCTION TEST

FAULT ISOLATION PROCEDURE

INITIAL STEP

Applicable Configurations:
All

Tools:
Electronic Repairer's Tool Kit,
NSN 5180-00-064-5178
Multimeter

Materials:
None

Personnel Required:
35M20 Avionic Navigation and Flight Control
Equipment Repairer.

Reference:
TM 55-1520-240-23

Equipment Condition:
Visual Check of CCDA performed (Task 11-6.2)

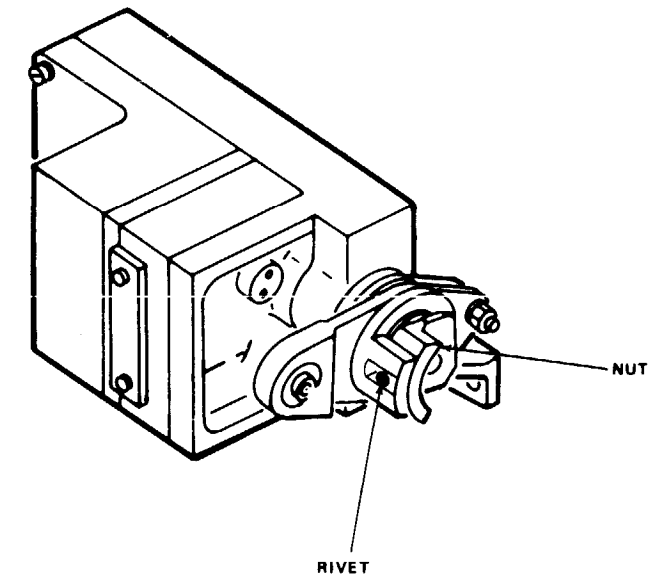
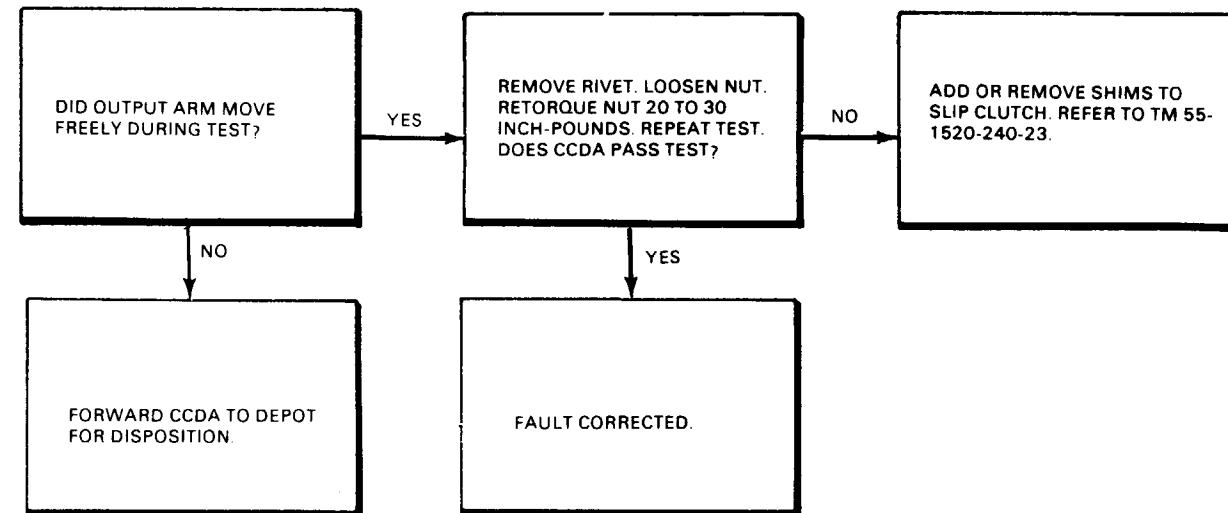

FAULT ISOLUTION PROCEDURE

INITIAL SETUP

Applicable Configurations:

All

Tools:

Electronic Repairer's Tool Kit,
NSN 5180-00-064-5178
Multimeter

Materials:

None

Personnel Required:

Avionic Navigation and Flight Control
Equipment Repairer.

Reference:

TM 55-1520-240-23

Equipment Condition:

Visual Check of CCDA Performed (Task 11-6.2)

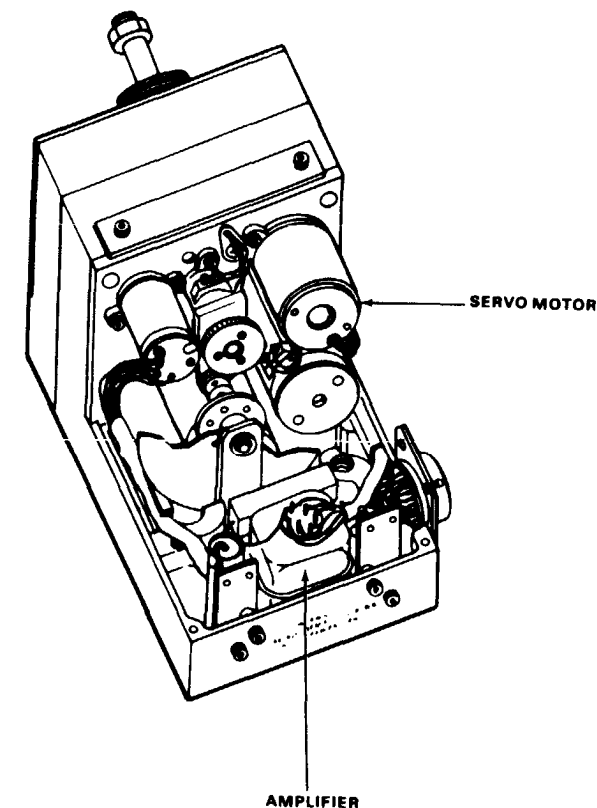
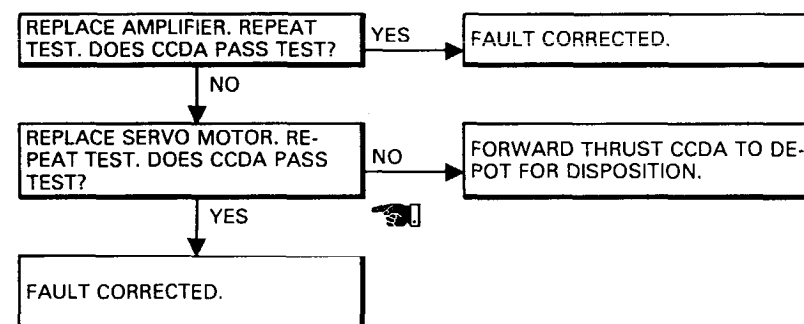

D145-12474-SPA

FAULT ISOLATION PROCEDURE

INITIAL SETUP

Applicable Configurations:

All

Tools:

Electronic Repairer's Tool Kit,
NSN 5180-00-064-5178
Multimeter

Materials:

None

Personnel Required:

Avionic Navigation and Flight Control
Equipment Repairer.

Reference:

TM 55-1520-240-23

Equipment Condition:

Visual Check of CCDA Performed (Task 11-6.2)

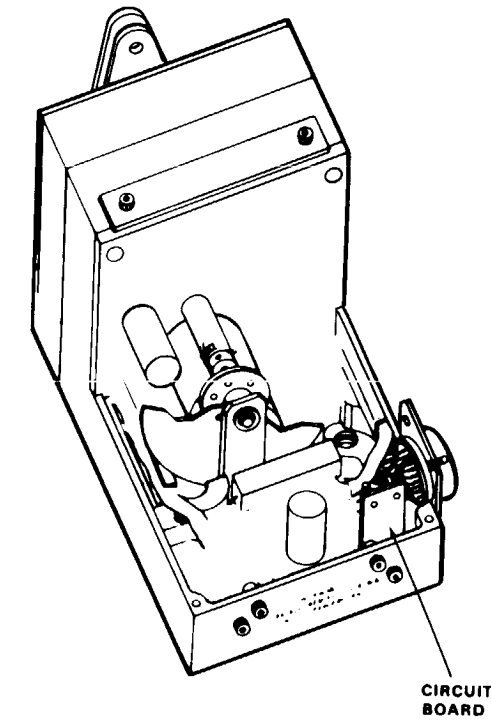
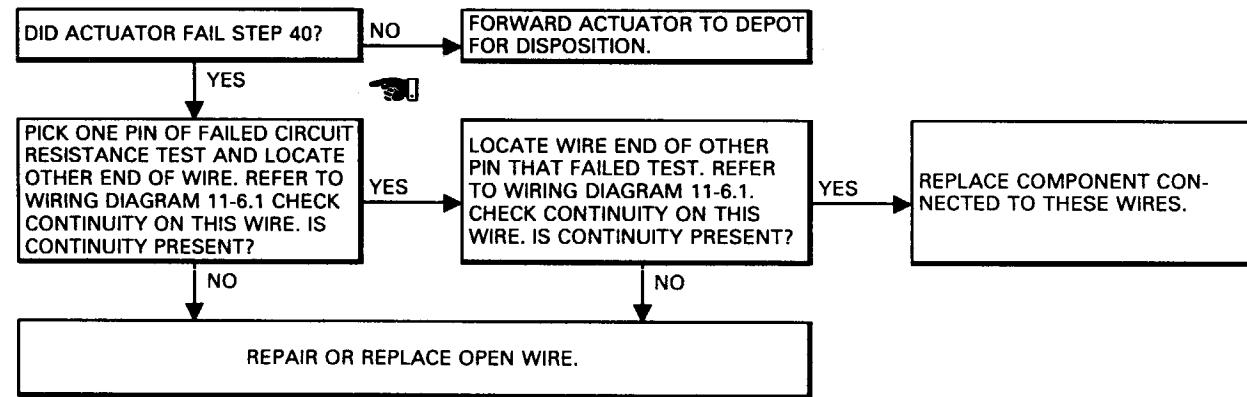

D146-12475-SPA

11-6.7 PITCH COCKPIT CONTROL DRIVE ACTUATOR
FAILS BRAKE FUNCTION TEST

FAULT ISOLATION PROCEDURE

INITIAL SETUP

Applicable Configurations:

All

Tools:

Electronic Repairer's Tool Kit,
NSN 5180-00-064-5178
Multimeter

Materials:

None

Personnel Required

35M20 Avionic Navigation and Flight Control
Equipment Repairer.

Reference:

TM 55-1520-240-23

Equipment Condition:

Visual Check of CCDA Performed (Task 11-6.2)

FORWARD CCDA TO DEPOT
FOR DISPOSITION

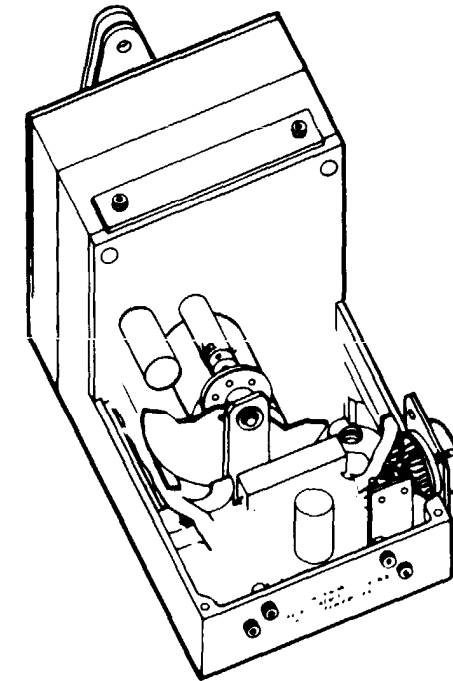

PITCH CCDA

11-6.8 PITCH COCKPIT CONTROL DRIVE ACTUATOR
FAILS TRIM MOTOR TEST

FAULT ISOLATION PROCEDURE

INITIAL SETUP

Applicable Configurations:

All

Tools:

Electronic Repairer's Tool Kit,
NSN 5180-00-064-5178
Multimeter

Materials:

None

Personnel Required:

35M20 Avionic Navigation and Flight Control
Equipment Repairer.

Reference:

TM 55-1520-240-23

Equipment Condition:

Visual Check of CCDA Performed (Task 11-6.2)

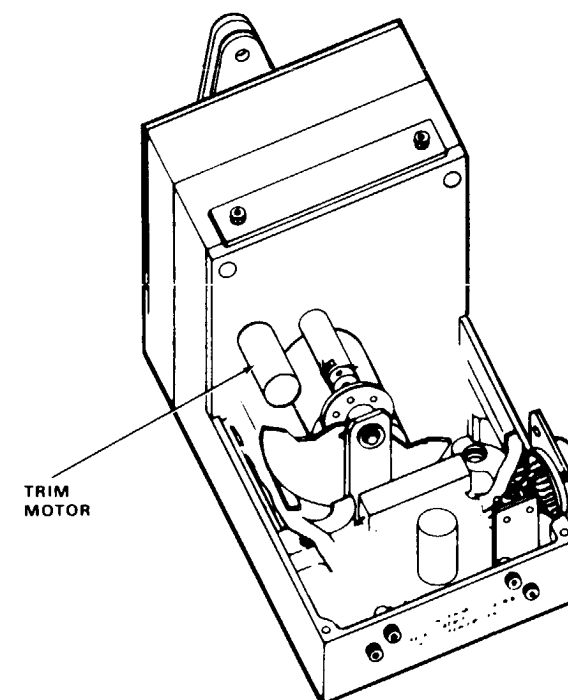
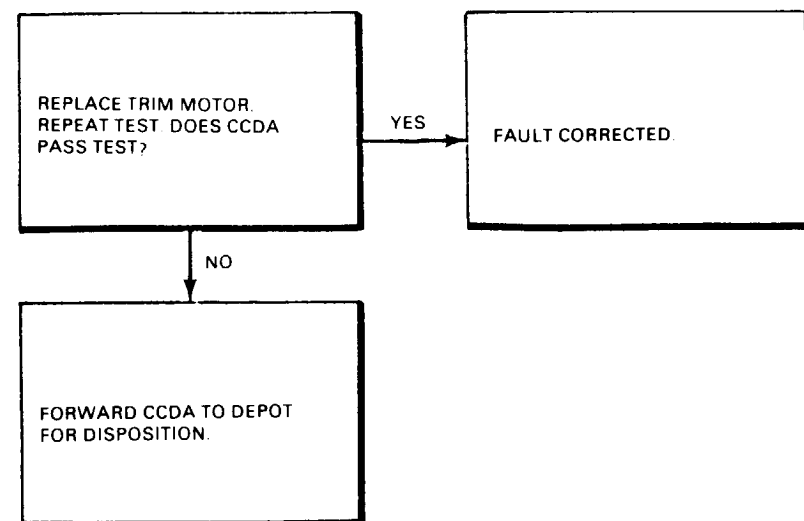

CHAPTER 12

UTILITY SYSTEMS TROUBLESHOOTING

CHAPTER 12
UTILITY SYSTEM TROUBLESHOOTING

CHAPTER OVERVIEW

Chapter 12 contains procedures for Utility System troubleshooting. Each system and failure symptom is listed below. Included in this chapter are locations and views of all electrical connectors, receptacles, relays, and ground connections for the Utility System

Refer to TM 55-1520-240-23 for required maintenance procedures.

SYSTEM	PARA	SYSTEM	PARA
WINDSHIELD ANTI-ICING	12-1	FIRE EXTINGUISHING	12-3
FIRE DETECTION	12-2	WINDSHIELD WIPERS	12-4

FAILURE SYMPTOM LIST

WINDSHIELD ANTI-ICING

SYMPTOM	TASK	SYMPTOM	TASK	SYMPTOM	TASK
CTR WSHLD ANTI-ICE CONT CIRCUIT BREAKER WILL NOT STAY CLOSED	12-1.3	COPLT WSHLD CONT CIRCUIT BREAKER WILL NOT STAY CLOSED	12-1.3	PILOT WSHLD ANTI-ICE CONT CIRCUIT BREAKER WILL NOT STAY CLOSED	12-1.3
CTR WSHLD ANTI-ICE HEAT CIRCUIT BREAKER WILL NOT STAY CLOSED	12-1.3	COPLOT'S WINDSHIELD CONTINUES TO HEAT WHEN CPLT WINDSHIELD ANTI-ICE SWITCH IS AT OFF	12-1.3	PILOT WSHLD ANTI-ICE HEAT CIRCUIT BREAKER WILL NOT STAY CLOSED	12-1.3
CENTER WINDSHIELD CONTINUES TO HEAT WHEN CTR WINDSHIELD SWITCH IS AT OFF	12-1.3	COPLOT'S WINDSHIELD DOES NOT GET WARM	12-1.3	PILOT'S WINDSHIELD CONTINUES TO HEAT WHEN PLT WINDSHIELD SWITCH IS AT OFF	12-1.3
CENTER WINDSHIELD DOES NOT GET WARM	12-1.3	COPLT WSHLD HEAT CIRCUIT BREAKER WILL NOT STAY CLOSED	12-1.3	PILOT'S WINDSHIELD DOES NOT GET WARM	12-1.3
FIRE DETECTION					
FIRE DET CIRCUIT BREAKER WILL NOT STAY CLOSED	12-2.4	NO. 1 ENGINE FIRE HANDLE FIRE PULL/FUEL SHUT-OFF CAPTION DOES NOT LIGHT DURING TEST	12-2.4	NO. 2 ENGINE FIRE HANDLE FIRE PULL/FUEL SHUT-OFF CAPTION DOES NOT LIGHT DURING TEST	12-2.4
NO. 1 ENGINE AND NO. 2 ENGINE FIRE HANDLE FIRE PULL/FUEL SHUTOFF CAPTIONS DO NOT LIGHT DURING TEST	12-2.4	NO. 1 ENGINE FIRE HANDLE FIRE PULL/FUEL SHUT-OFF CAPTION LIT	12-2.4	NO. 2 ENGINE FIRE HANDLE FIRE PULL/FUEL SHUT-OFF CAPTION LIT	12-2.4

FAILURE SYMPTOM LIST (Continued)

FIRE EXTINGUISHER

SYMPTOM	TASK
FIRE EXT CIRCUIT BREAKER WILL NOT STAY CLOSED	12-3.4
MULTIMETER DOES NOT INDICATE 28 VDC WITH NO. 1 ENGINE FIRE HANDLE OUT AND FIRE EXT AGENT SWITCH AT BOTTLE NO. 1	12-3.4
WINDSHIELD WIPERS ARE NOISY	12-4.3
WINDSHIELD WIPER CIRCUIT BREAKER WILL NOT STAY CLOSED	12-4.3

SYMPTOM	TASK
MULTIMETER DOES NOT INDICATE 28 VDC WITH NO. 1 ENGINE FIRE HANDLE OUT AND FIRE EXT AGENT SWITCH AT BOTTLE NO. 2	12-3.4
MULTIMETER DOES NOT INDICATE 28 VDC WITH NO. 2 ENGINE FIRE HANDLE OUT AND FIRE EXT AGENT SWITCH AT BOTTLE NO. 1	12-3.4

WINDSHIELD WIPERS

WINDSHIELD WIPERS DO NOT RETURN TO PARK POSITION	12-4.3
--	--------

SYMPTOM	TASK
MULTIMETER DOES NOT INDICATE 28 VDC WITH NO. 2 ENGINE FIRE HANDLE OUT AND FIRE EXT AGENT SWITCH AT BOTTLE NO. 2	12-3.4
WINDSHIELD WIPER OR WIPERS DO NOT OPERATE AT ONE SWITCH POSITION OR ANY SWITCH POSITION	12-4.3

UTILITY SYSTEM ELECTRICAL COMPONENT LOCATION AND CONFIGURATION LIST

REF DESIG	PART NUMBER	TYPE	MATE WITH/LOCATION	STATION LOCATION			REF DESIG	PART NUMBER	TYPE	MATE WITH/LOCATION	STATION LOCATION		
				FS	WL	BL					FS	WL	BL
GD031		151	CONSOLE - FWD CTR INST PNL				300P4	M83723-75A2461N	43	NO. 1 PDP			
GD035		150	FWD AND ABOVE OVHD PNL	61	40	10L	300J5	M83723-74A2041N	40	NO. 2 PDP			
GD038		151	NOSE COMPARTMENT	40	0	0	300P5	M83723-75A2041N	40	NO. 2 PDP			
GD041		151	UNDER RH COCKPIT FLOOR	95	-25	30R	300J6	M83723-74A24616	43	NO. 2 PDP			
GD042		151	UNDER LH COCKPIT FLOOR	90	-20	35L	300P6	M83723-75A24616	43	NO. 2 PDP			
GD098		151	LH AFT CABIN	477	30	52L	300J8	M83723-74A2461N	42	NO. 2 PDP			
GD099		151	RH AFT CABIN	508	25	50R	300P8	M83723-75A2461N	42	NO. 2 PDP			
GD124		151	UNDER AFT PYLON	500	72	0	300J11	M83723-73A2255N	42	CONSOLE-UNDERFLOOR	85	-20	5R
GD125		151	UNDER AFT PYLON	500	72	0	300P11	M83723-76A2255N	42	CONSOLE-UNDERFLOOR	85	-20	5R
GD246		151	UNDER AFT PYLON	500	72	0	300J15	M83723-74A24617	43	CONSOLE-UNDERFLOOR	85	-20	10R
GD247		151	UNDER AFT PYLON	500	72	0	300P15	M83723-75A24617	43	CONSOLE-UNDERFLOOR	85	-20	10R
GD282		151	NOSE COMPARTMENT	40	0	0	300J18	M83723-73A2041N	40	OVERHEAD PANEL-COCKPIT			
GD284		151	NOSE COMPARTMENT	40	0	0	300P18	M83723-76A2041N	40	OVERHEAD PANEL-COCKPIT			
GD285		151	NOSE COMPARTMENT	40	0	0	300J19	M83723-73A2041N	40	OVERHEAD PANEL-COCKPIT			
TB 36			OVERHEAD PANEL-COCKPIT	80	40	12R	300P19	M83723-76A2041N	40	OVERHEAD PANEL-COCKPIT			
TB 48			NOSE COMPARTMENT	50	-15	2L	300J20	M83723-74A2461N	43	OVERHEAD PANEL-COCKPIT			
TB 62			NO. 2 PDP SIDE PANEL	90	-15	30R	300P20	M83723-75A2461N	43	OVERHEAD PANEL-COCKPIT			
083K1	MS25035-1	110	NOSE COMPARTMENT	45	-10	8L	300J23	M83723-74A2255N	42	OVERHEAD PANEL-COCKPIT			
083K2	MS24149D1	106	NOSE COMPARTMENT	40	-17	2L	300P23	M83723-75A2255N	42	OVERHEAD PANEL-COCKPIT			
083K3	MS25035-1	110	NOSE COMPARTMENT	45	-10	5L	300J45	M83723-73A2461N	43	HEATER COMPARTMENT - OVHD	105	40	30R
083P1	MS3476W16-8S	22	CPLT WSHLD TEMP CONT-NOSE	45	-10	0	300P45	M83723-76A2461N	43	HEATER COMPARTMENT - OVHD	105	40	30R
083P2	MS3476W16-8SW	22	CTR WSHLD TEMP CONT-NOSE	45	-10	4L	300J48	M83723-74A2461N	43	ELECTRONICS COMPARTMENT - OVHD	120	40	20L
083P3	MS3476W16-8S	22	PLT WSHLD TEMP CONT-NOSE	45	-10	8L	300P48	M83723-75A2461N	43	ELECTRONICS COMPARTMENT - OVHD	120	40	20L
133P1	MS3456W10SL-3S	45	WSHLD WIPER MOTOR	61	50	0	300J51	M83723-74A2461N	43	AFT CROWN	460	45	20R
231P1	35303-11	FENWAL	NO. 1 ENG DISC.	484	45	52L	300P51	M83723-75A2461N	43	AFT CROWN	460	45	20R
231P2	35303-11	FENWAL	NO. 1 ENG DISC.	484	45	52L	300J52	M83723-74A2255N	42	AFT CROWN	460	45	30L
231P3	35303-11	FENWAL	NO. 2 ENG DISC.	484	45	52R	300P52	M83723-75A2255N	42	AFT CROWN	460	45	30L
231P4	35303-11	FENWAL	NO. 2 ENG DISC.	484	45	52R	300J58	M83723-73A22558	42	CONSOLE - UNDERFLOOR	85	-20	12L
231P5	MS3456W18-8S	53	FIRE DET CONT	492	20	52L	300P58	M83723-76A22558	42	CONSOLE - UNDERFLOOR	85	-20	12L
231P6	MS3456W18-8S	53	FIRE DET CONT	492	20	52R	300J61	M83723-73A24619	43	CONSOLE - UNDERFLOOR (WITHOUT 74)	85	-20	10L
300J1	M83723-74A2041N	40	NO. 1 PDP				300J61	M83723-73W24619	43	CONSOLE - UNDERFLOOR (WITH 74)	85	-20	10L
300P1	M83723-75A2041N	40	NO. 1 PDP				300P61	M83723-76A24619	43	CONSOLE - UNDERFLOOR (WITHOUT 74)	85	-20	10L
300J2	M83723-74A2255N	42	NO. 1 PDP				300P61	M83723-76W24619	43	CONSOLE - UNDERFLOOR (WITH 74)	85	-20	10L
300P2	M83723-75A2255N	42	NO. 1 PDP										
300J4	M83723-74A2461N	43	NO. 1 PDP										

UTILITY SYSTEM ELECTRICAL COMPONENT LOCATION AND CONFIGURATION LIST (Continued)

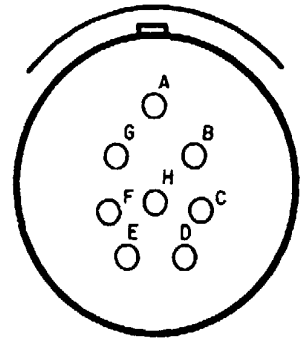

22

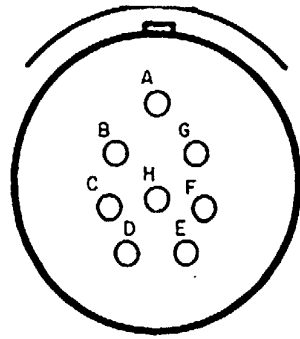

22

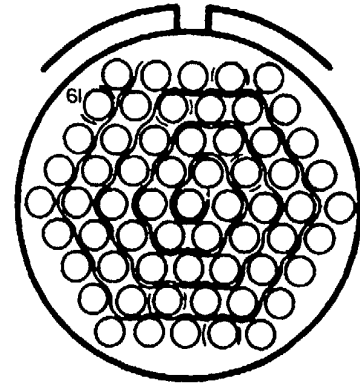

42

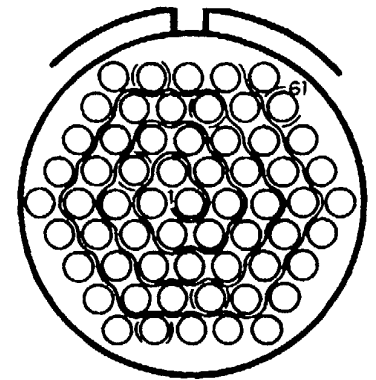

42

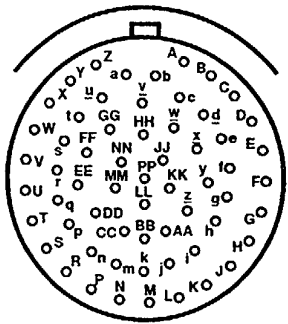

28

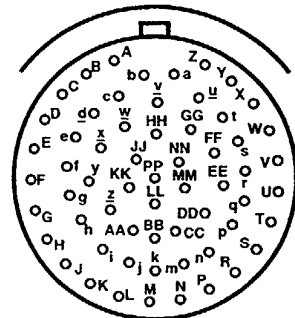

28

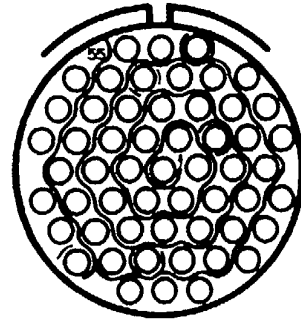

43

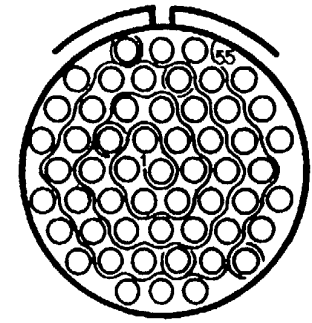

43

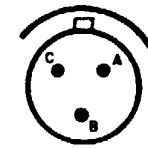

45

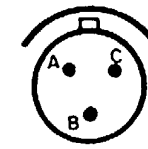

45

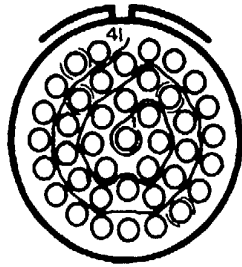

40

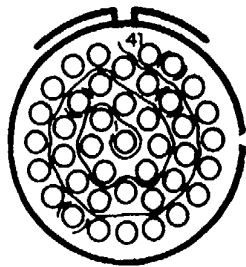

40

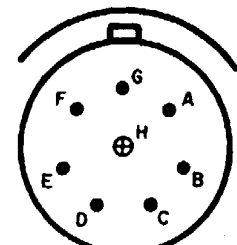

53

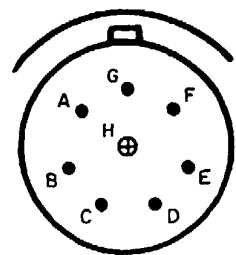

53

UTILITY SYSTEMS ELECTRICAL COMPONENT
LOCATION AND CONFIGURATION LIST (Continued)

RELAY

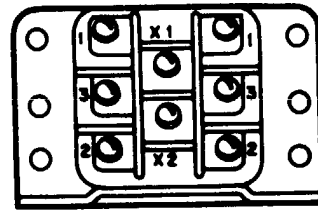

106

RELAY

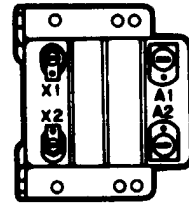

110

GND MODULE

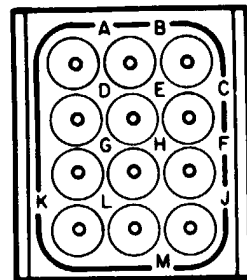

150

GND STUD



151

12-1 WINDSHIELD ANTI-ICING SYSTEM

12-1 WINDSHIELD ANTI-ICING SYSTEM

12-1.1 WINDSHIELD ANTI-ICING SYSTEM WIRING DIAGRAM

12-1

12-1.1

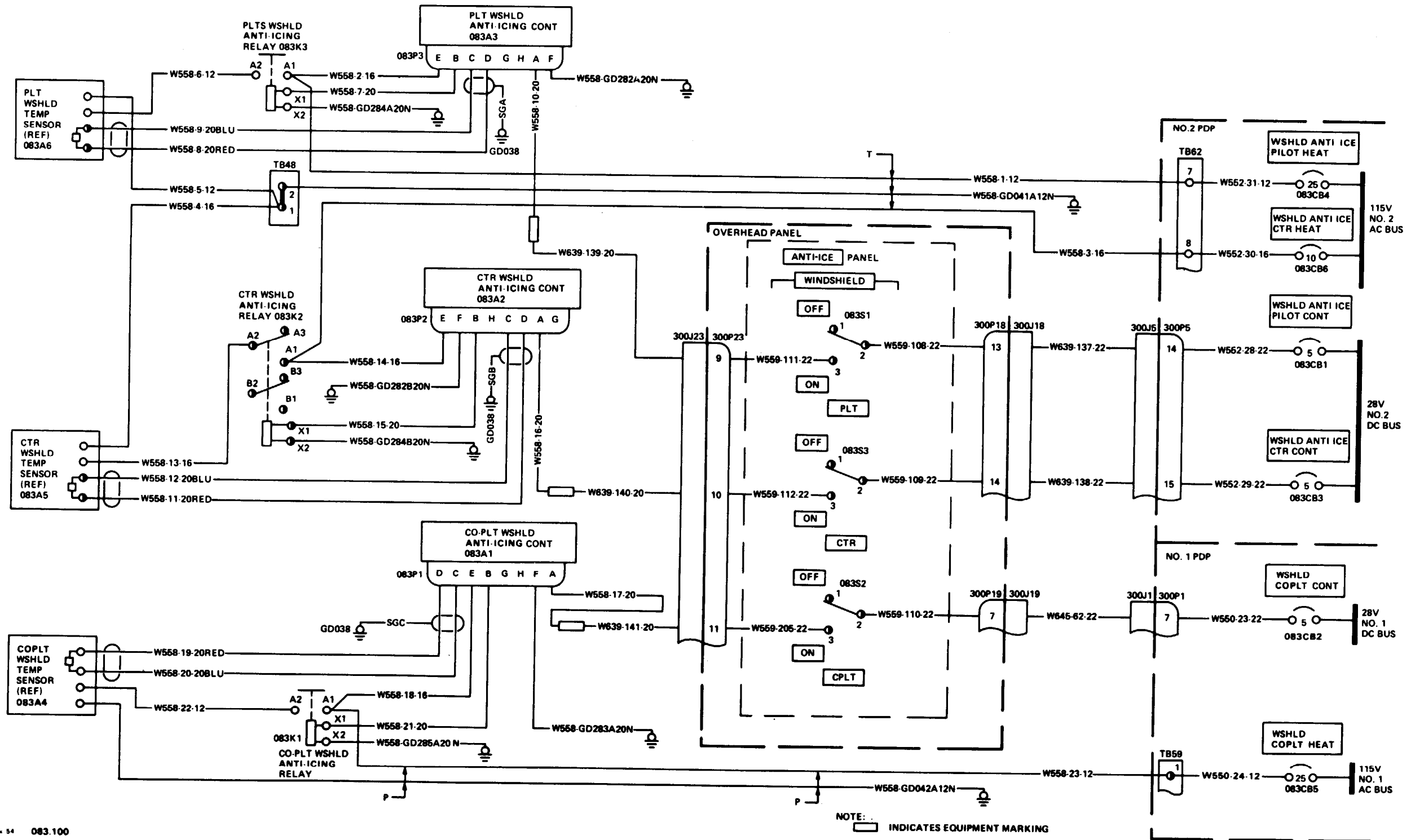

90-54 083.100

U145 4879 S/A

12-1.2 WINDSHIELD ANTI-ICING SYSTEM VISUAL CHECK

12-1.2

INITIAL SETUP

Applicable Configurations:

All

Tools:

Aircraft Mechanic's Tool Kit,
NSN 5180-00-323-4692

Materials:

None

Personnel Required:

67U10 Medium Helicopter Repairer

References:

TM 55-1520-240-23

Equipment Condition:

TM 55-1520-240-23:
Battery Disconnected
Electrical Power Off
Hydraulic Power Off

TASK	RESULT
1. Check pilot's, center, and copilot's windshields (1, 2, and 3).	If any windshield (1, 2, or 3) is damaged or discolored, replace it. If wiring to windshield terminals is loose or damaged, tighten terminals or repair or replace wire as required.
2. Check PLT, CTR, and CPLT WINDSHIELD anti-ice switches (4, 5, 6).	If any switch (4, 5, or 6) is loose or damaged, tighten or replace it as required.

FOLLOW-ON MAINTENANCE:

None

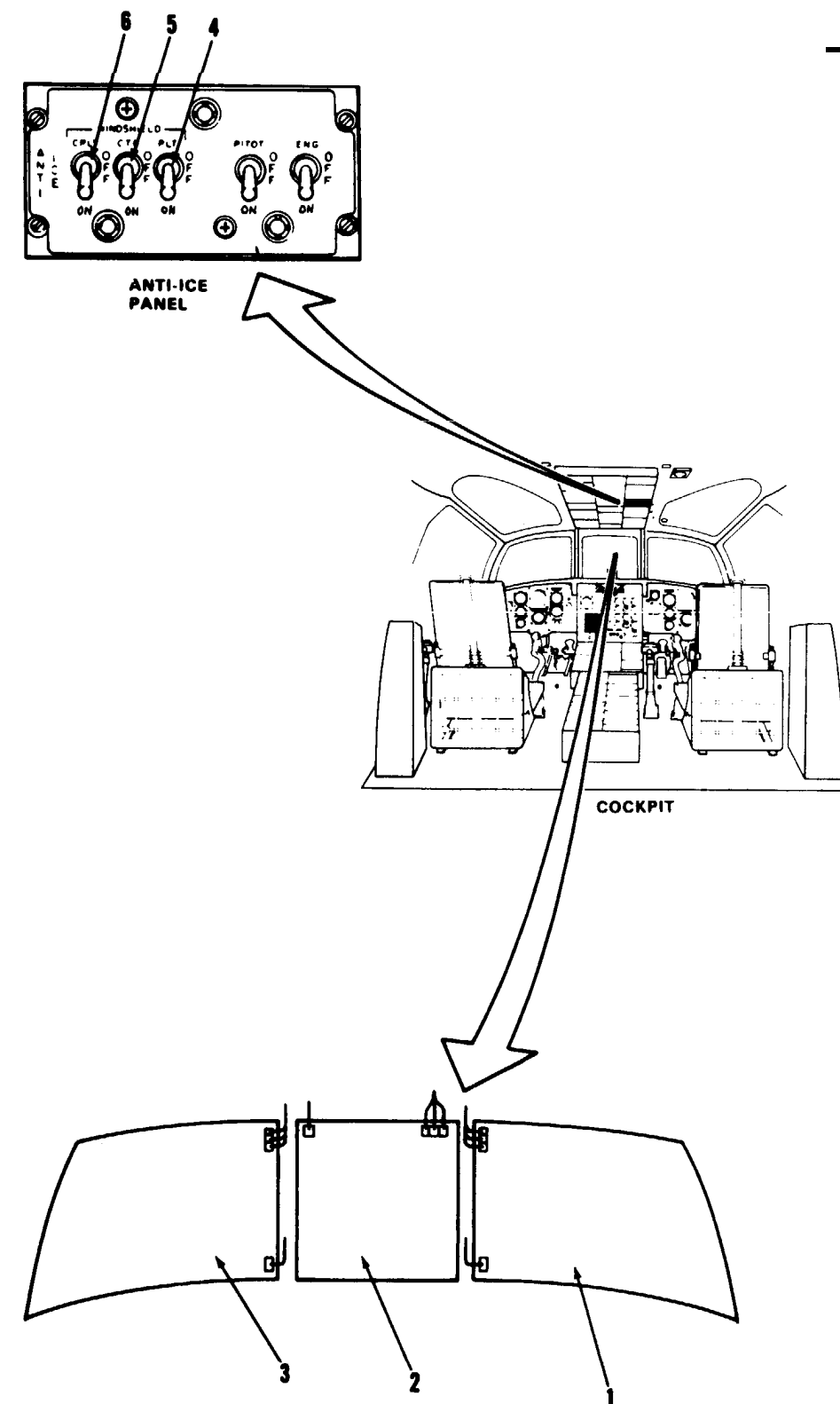

12-1.3 WINDSHIELD ANTI-ICING SYSTEM OPERATIONAL CHECK

INITIAL SETUP

Applicable Configurations:

All

Tools:

None

Materials:

None

Personnel Required:

68F20 Aircraft Electrician

References:

TM 55-1520-240-23

Equipment Condition:

TM 55-1520-240-23:

Battery Connected

Electrical Power On

Hydraulic Power Off

Visual Check of Windshield Anti-Icing System

Performed (Task 12-1.2)

Outside Air Temperature Below 70° F (20°C) or

Windshields Cooled With Water Hose.

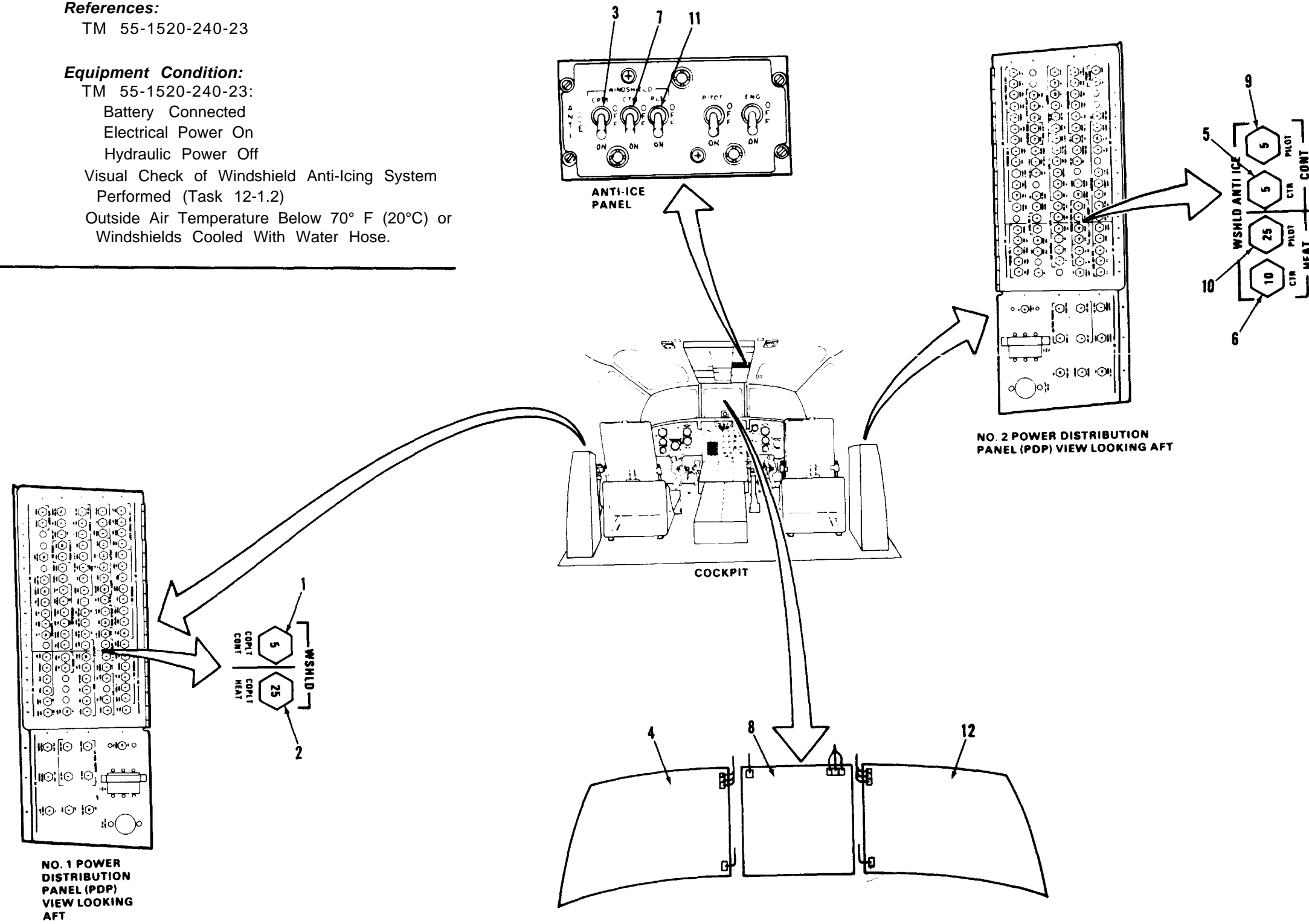

12-1.3 WINDSHIELD ANTI-ICING SYSTEM OPERATIONAL CHECK
(Continued)

12-1.3

TASK	RESULT
CHECK COPILOTS WINDSHIELD ANTI-ICING	
1. Check that COPLT WSHLD CONT and COPLT WSH LD HEAT circuit breakers (1 and 2) are closed.	If COPLT WSHLD CONT or COPLT WSHLD HEAT circuit breaker (1 or 2) is open, close it. If COPLT WSHLD CONT circuit breaker opens again, go to task 12-1.4. If COPLT WSHLD HEAT circuit breaker opens again, go to task 12-1.5.
2. Set CPLT WINDSHIELD anti-ice switch (3) to ON. Touch copilot's windshield (4).	Copilot's windshield (4) shall begin to get warm and heat up before automatic heat cycling begins. If windshield does not get warm, go to task 12-1.6. If windshield temperature does not cycle replace copilot's windshield anti-icing control box.
3. Set CPLT WINDSHIELD anti-ice switch (3) to OFF. Touch copilot's windshield (4).	Copilot's windshield (4) shall stop heating. If it continues to heat, go to task 12-1.7.
CHECK CENTER WINDSHIELD ANTI-ICING	
4. Check that CTR WSHLD ANTI-ICE CONT and CTR WSHLD ANTI-ICE HEAT circuit breakers (5 and 6) are closed.	If CTR WSHLD ANTI-ICE CONT or CTR WSHLD ANTI-ICE HEAT circuit breaker (5 or 6) is open, close it. If CTR WSHLD ANTI-ICE CONT circuit breaker opens again, go to task 12-1.8. If CTR WSHLD ANTI-ICE HEAT circuit breaker opens again, go to task 12-1.9.
5. Set CTR WINDSHIELD anti-ice switch (7) to ON. Touch center windshield (8).	Center windshield (8) shall begin to get warm and heat up before automatic heat cycling begins. If windshield does not get warm, go to task 12-1.10. If windshield temperature does not cycle, replace center windshield anti-icing control box.
6. Set CTR WINDSHIELD anti-ice switch (7) to OFF. Touch center windshield (8).	Center windshield (8) shall stop heating. If it continues to heat, go to task 12-1.11.

TASK	RESULT
CHECK PILOT'S WINDSHIELD ANTI-ICING	
7. Check that PILOT WSHLD ANTI-ICE CONT AND PILOT WSHLD ANTI-ICE HEAT circuit breakers (9 and 10) are closed.	If PILOT WSHLD ANTI-ICE CONT or PILOT WSHLD ANTI-ICE HEAT circuit breaker (9 or 10) is open, close it. If PILOT WSHLD ANTI-ICE CONT circuit breaker opens again, go to task 12-1.12. If PILOT WSHLD ANTI-ICE HEAT circuit breaker opens again, go to task 12-1.13.
8. Set PLT WINDSHIELD anti-ice switch (11) to ON. Touch pilot's windshield (12).	Pilot's windshield (12) shall begin to get warm and heat up before automatic heat cycling begins. If windshield does not get warm, go to task 17-7 14. If windshield temperature does not cycle, replace pilot's windshield anti-icing control box.
9. Set PLT WINDSHIELD anti-ice switch (11) to OFF. Touch pilot's windshield (12).	Pilot's windshield (12) shall stop heating. If it continues to heat, go to task 12-1.15.

FOLLOW-ON MAINTENANCE:

TM 55-1520-240-23:
Electrical Power Off
Battery Disconnected

END OF TASK

FAULT ISOLATION PROCEDURE

INITIAL SETUP

Applicable Configurations:
All

Took
Electrical Repairer's Tool Kit,
NSN 5180-00-323-4915
Multi meter

Materials:
None

Personnel Required:
68F20 Aircraft Electrician

References:
TM 55-1520-240-23

Equipment Condition:
TM 55-1520-240-23:
Battery Disconnected
Electrical Power Off
Hydraulic Power Off

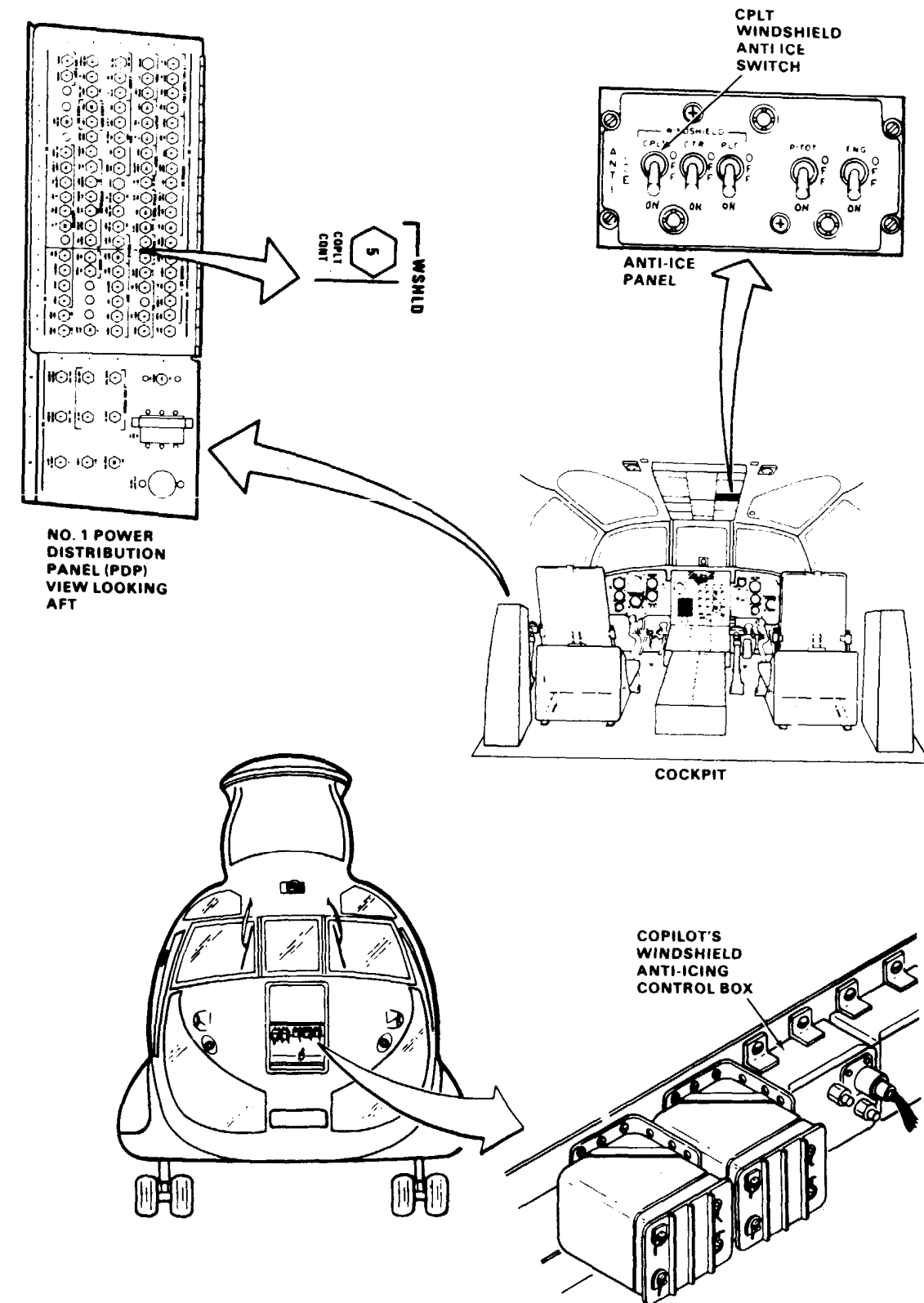
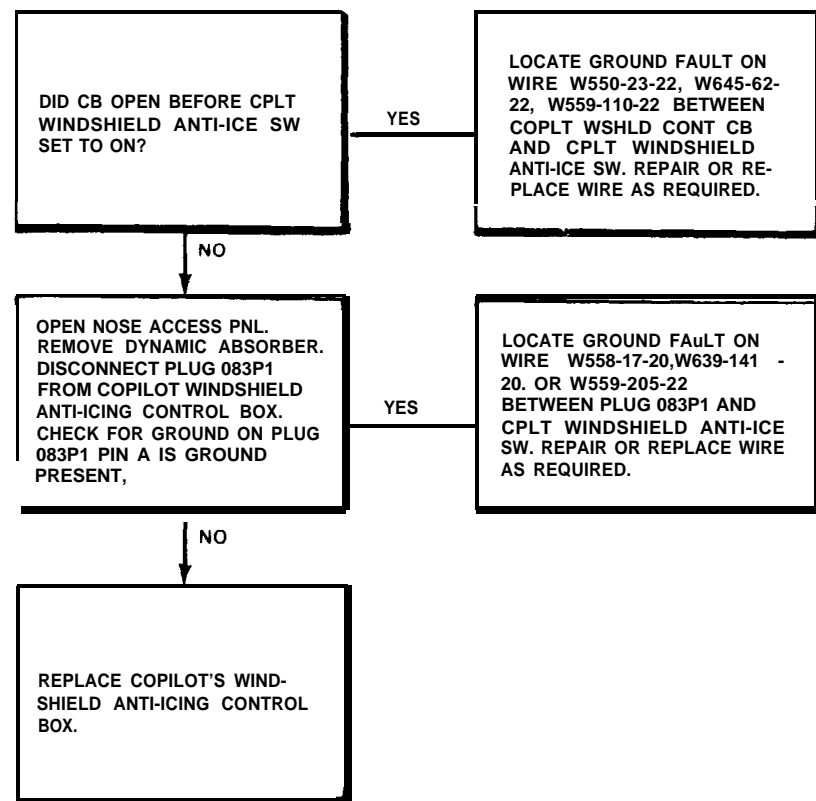

12-1.5 COPLT WSHLD HEAT CIRCUIT BREAKER WILL NOT STAY CLOSED

12-1.5

FAULT ISOLATION PROCEDURE

INITIAL SETUP

Applicable Configurations:
All

Tools:
Electrical Repairer's Tool Kit,
NSN 5180-00-323-4915
Multimeter

Materials:
None

Personnel Required:
68F20 Aircraft Electrician

References:
TM 55-1520-240-23

Equipment Condition:
TM 55-1520-240-23:
Battery Disconnected
Electrical Power Off
Hydraulic Power Off

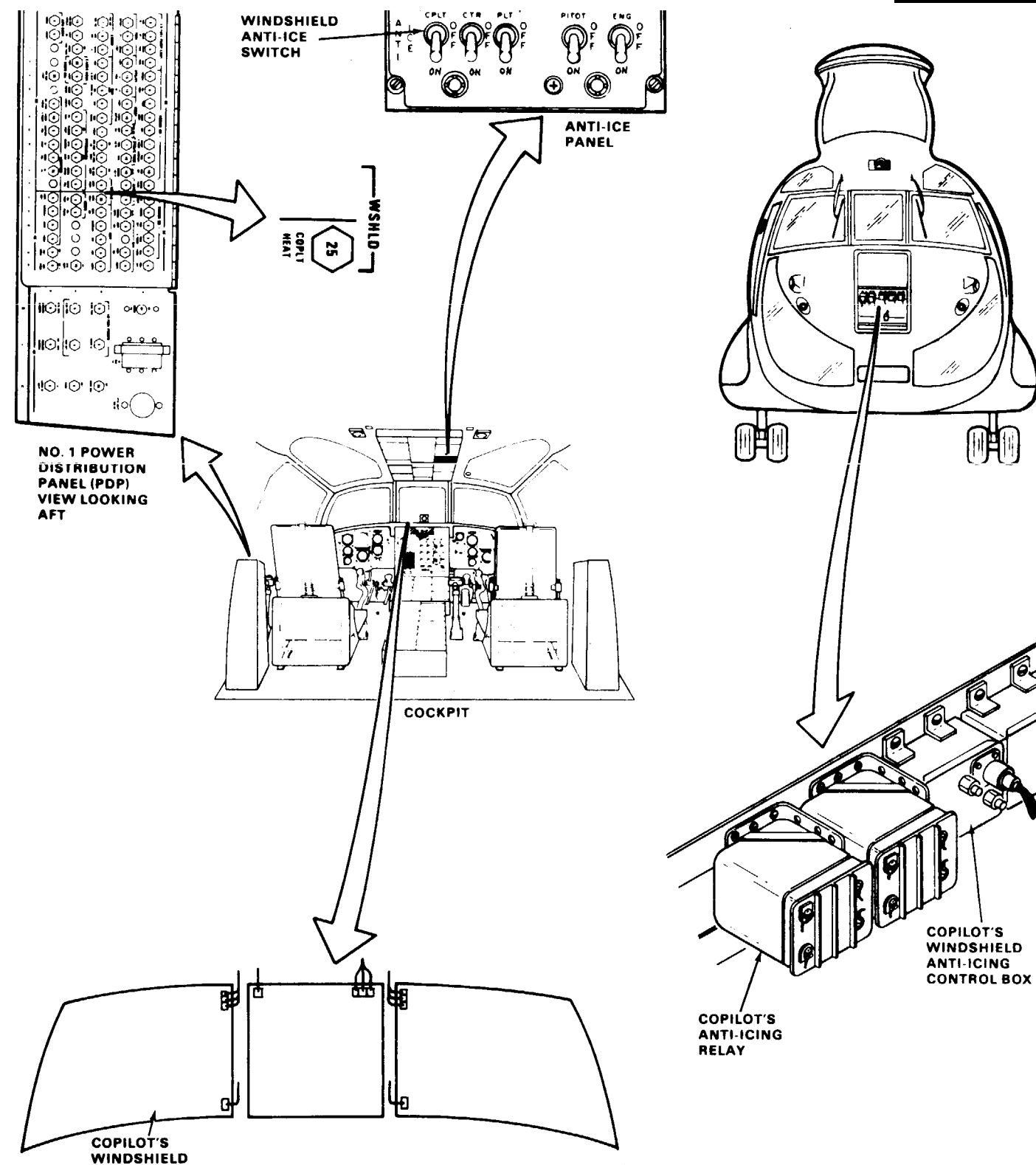
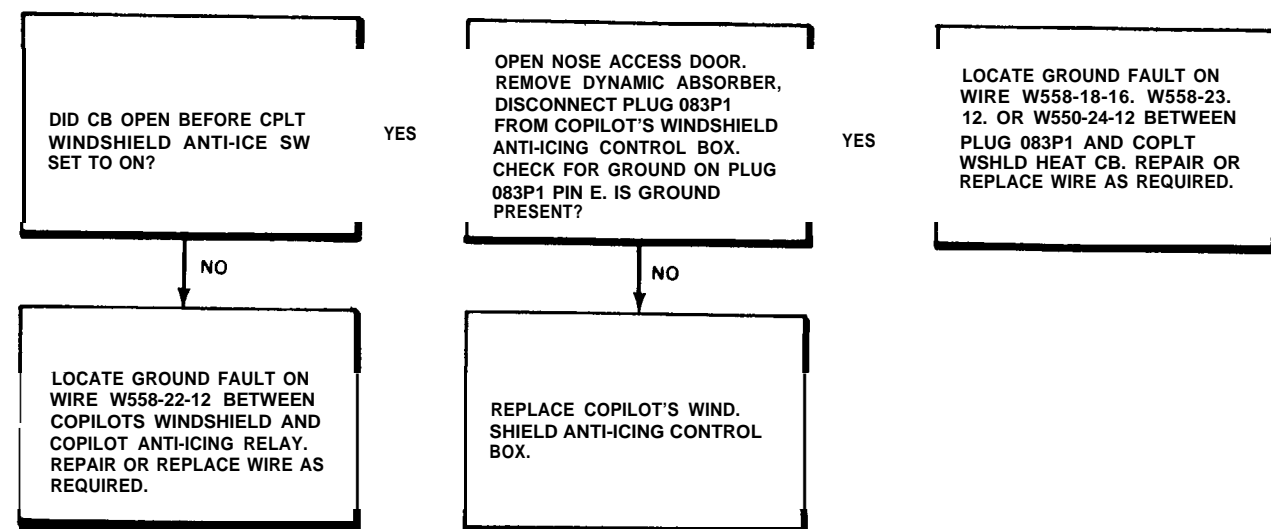

45x54

D145-5372-SPA

END OF TASK

12-1.6 COPILOT'S WINDSHIELD DOES NOT GET WARM

FAULT ISOLATION PROCEDURE

INITIAL SETUP

Applicable Configurations:

All

Tools:

Electrical Repairer's Tool Kit,
NSN 5180-00-323-4915
Multimeter

Materials:

None

Personnel Required:

68F10 Aircraft Electrician
68F20 Aircraft Electrician

References:

TM 55-1520-240-23

Equipment Condition:

TM 55-1520-240-23:
Battery Connected
Electrical Power On
Hydraulic Power Off

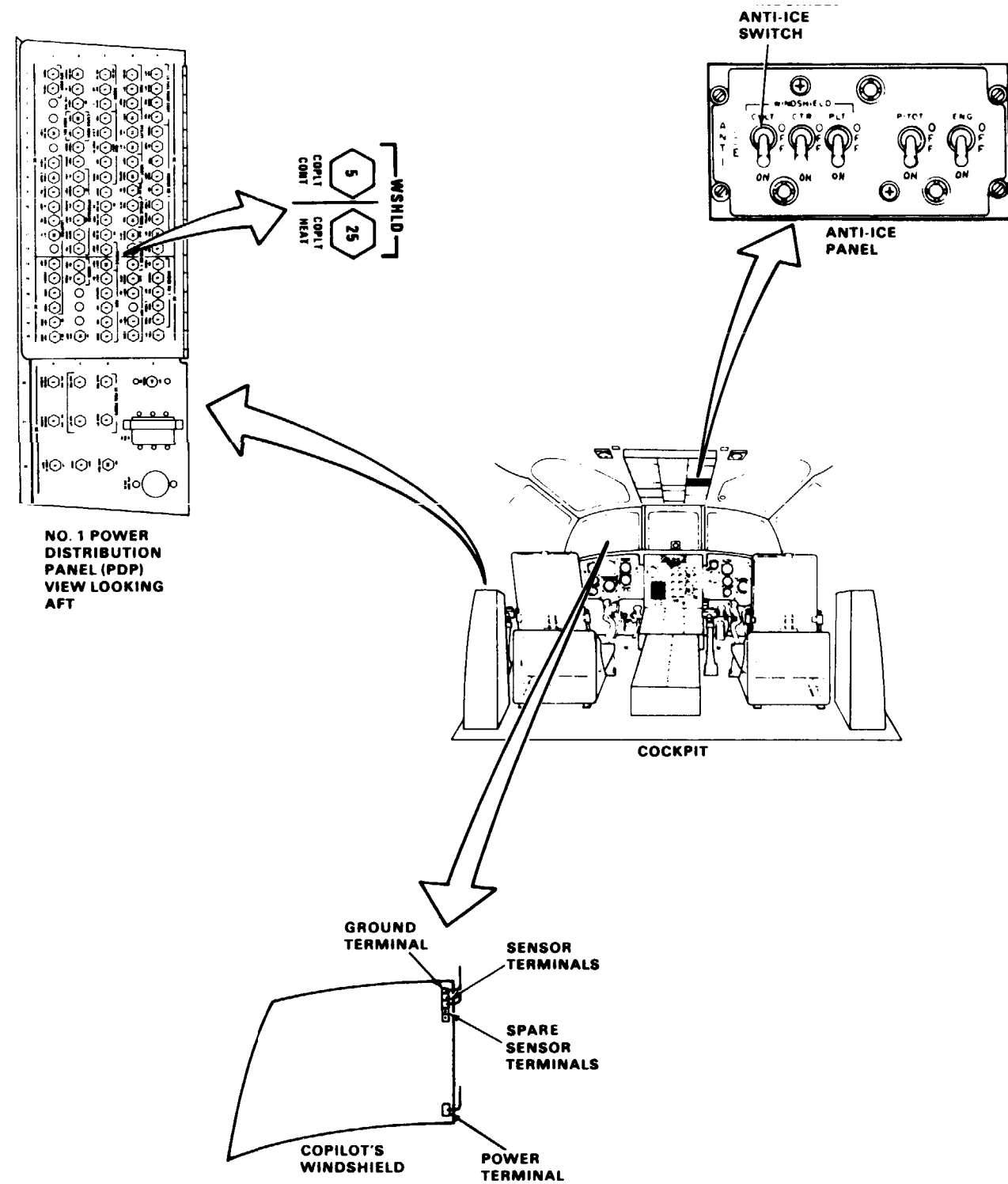
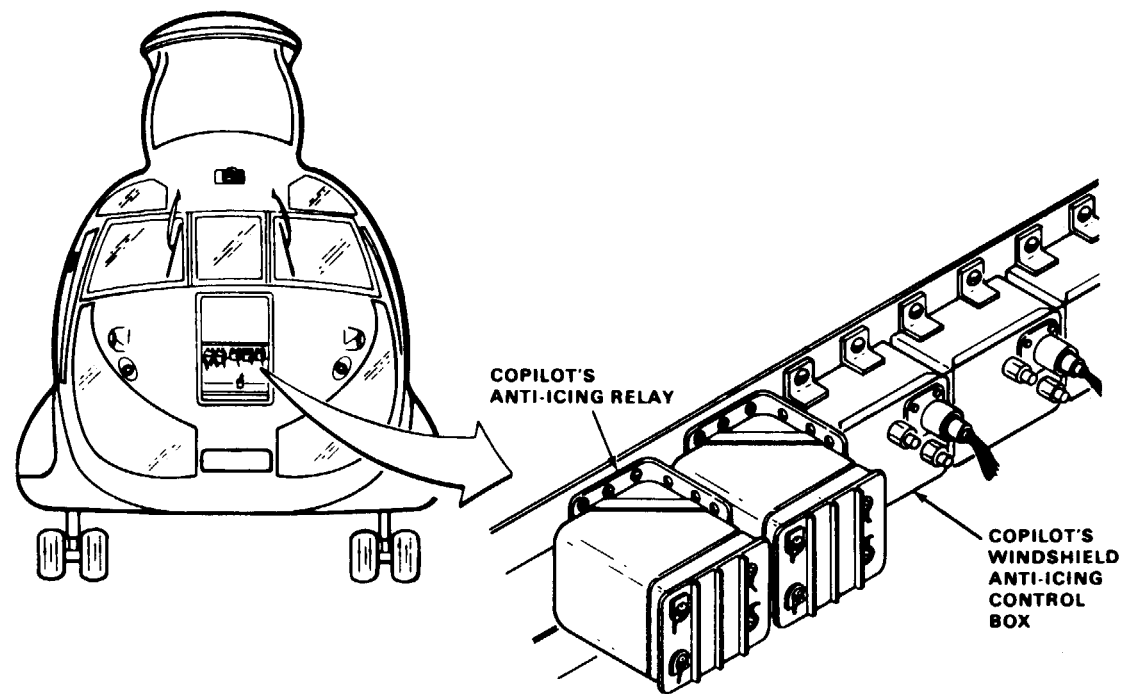

12-1.6 COPILOT'S WINDSHIELD DOES NOT GET WARM (Continued)

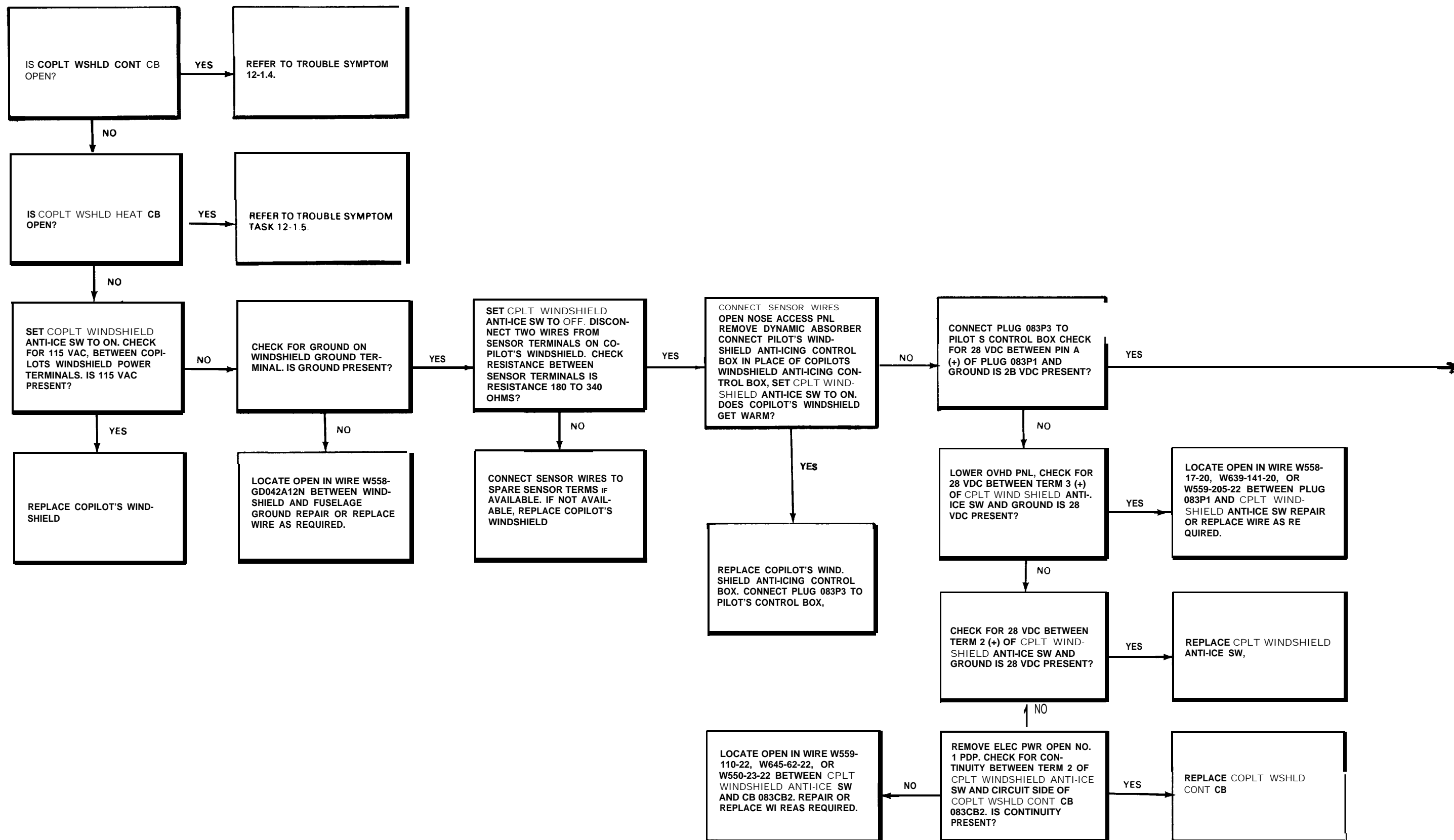

GO TO NEXT PAGE

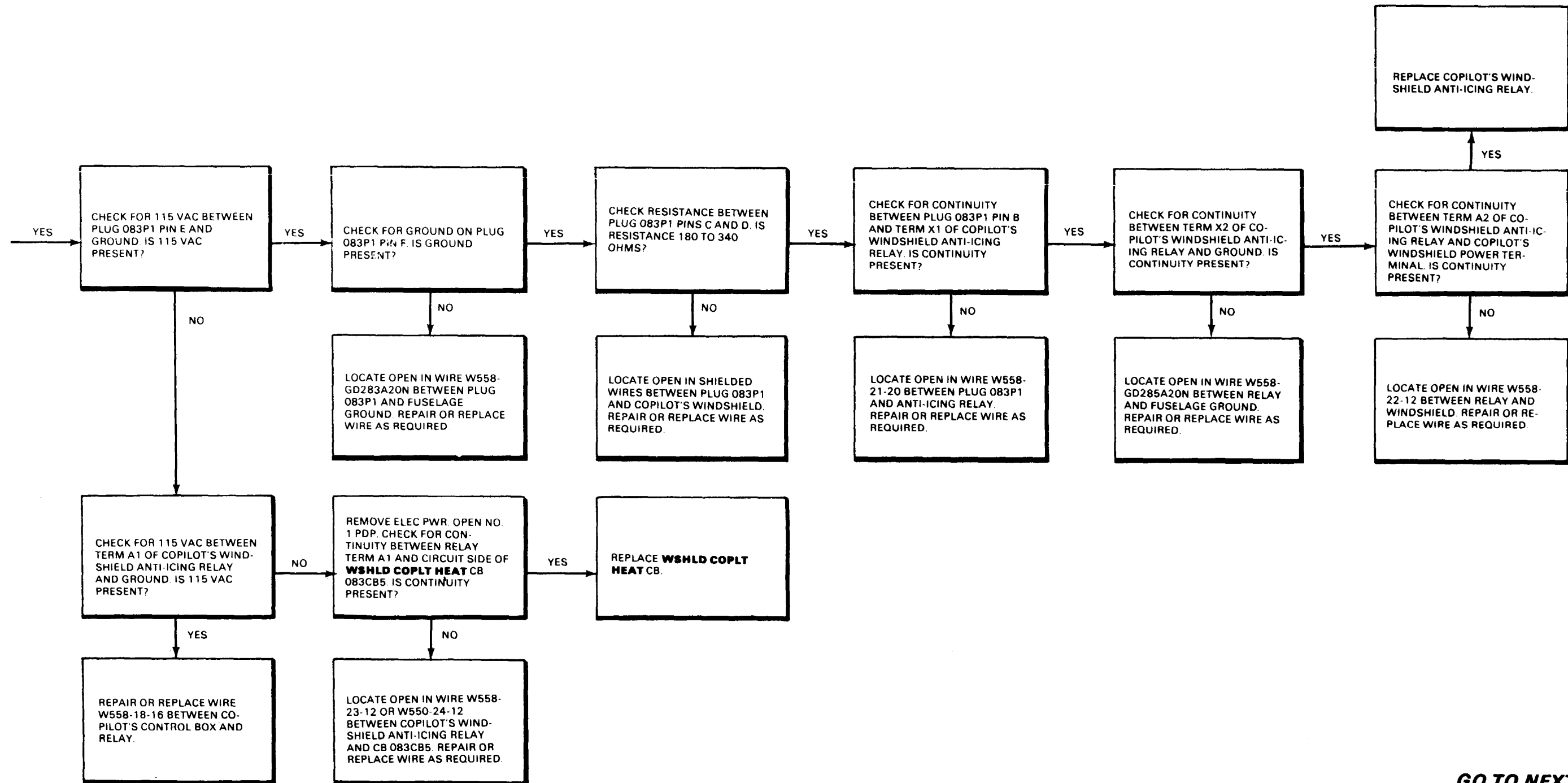

GO TO NEXT PAGE

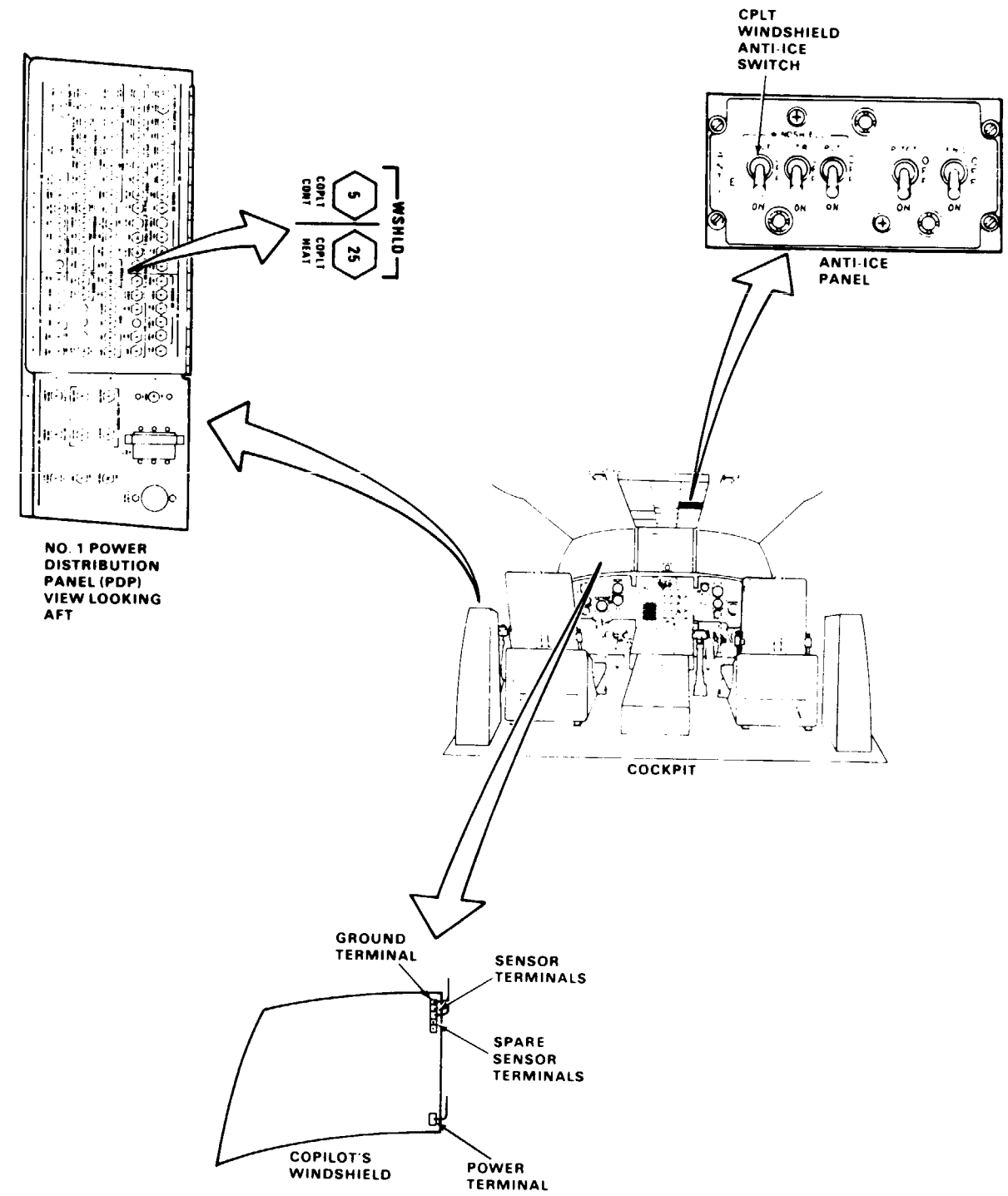
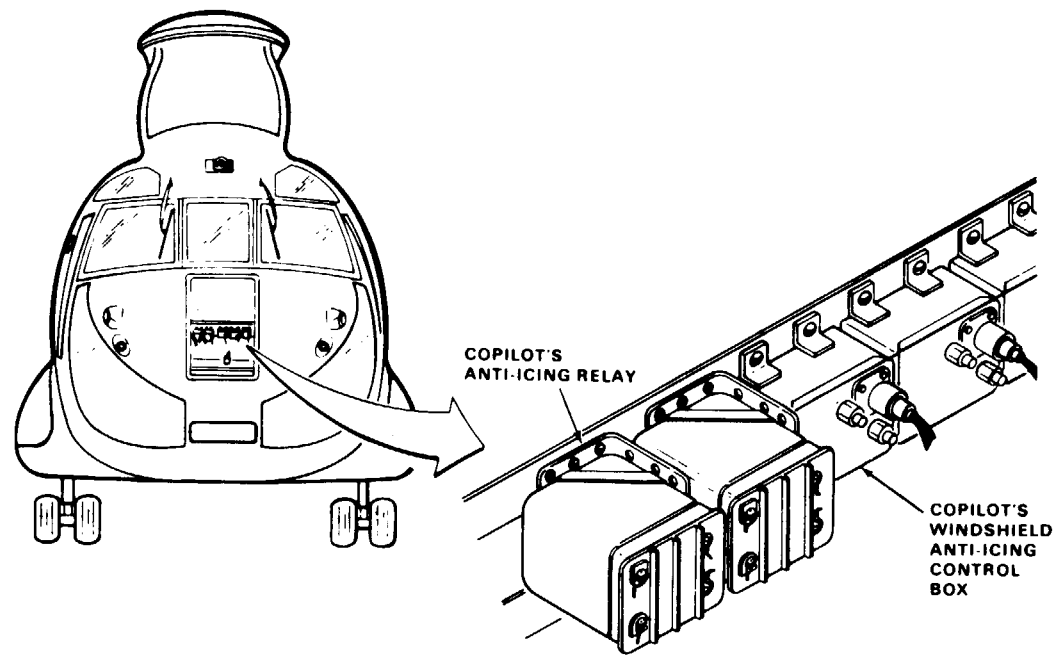

90 x 54

D145-11827-SPA

END OF TASK

12-1.7 COPILOT'S WINDSHIELD CONTINUES TO HEAT WHEN CPLT WINDSHIELD ANTI-ICE SWITCH IS AT OFF

FAULT ISOLATION PROCEDURE

INITIAL SETUP

Applicable Configurations:

All

Tools:

- Electrical Repairer's Tool Kit,
NSN 5180-00-323-4915
- Multimeter

Materials:

None

Personnel Required:

68F20 Aircraft Electrician

References:

TM 55-1520-240-23

Equipment Condition:

- TM 55-1520-240-23:
- Battery Connected
- Electrical Power On
- Hydraulic Power Off

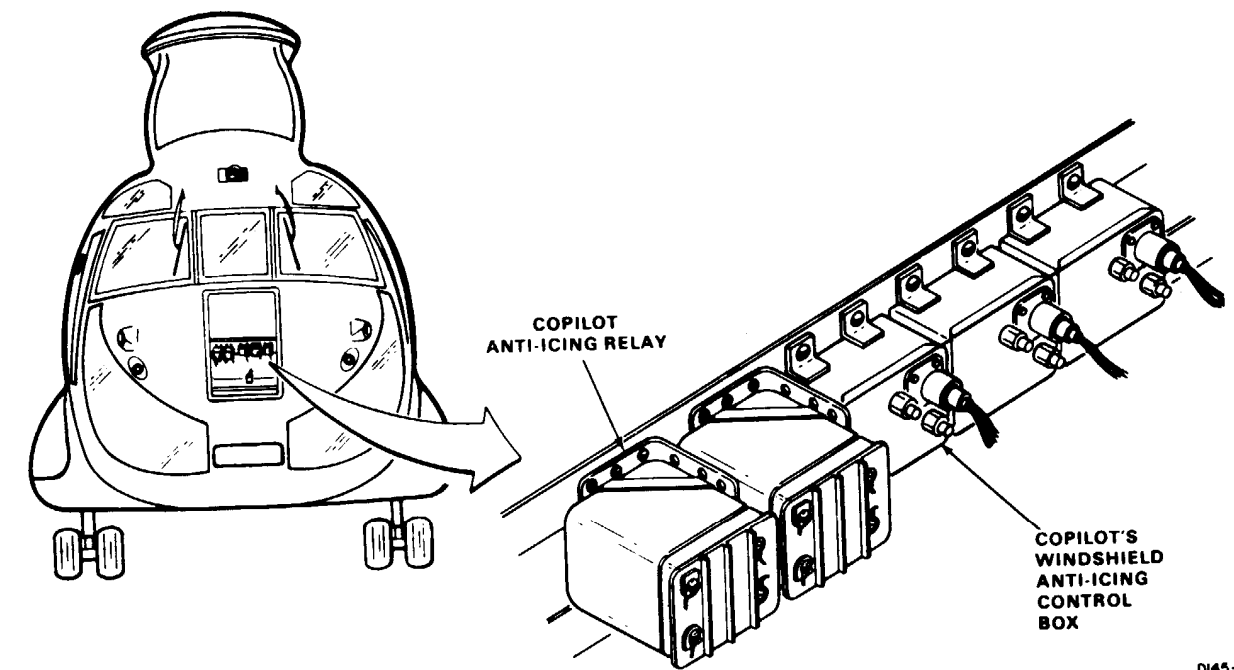
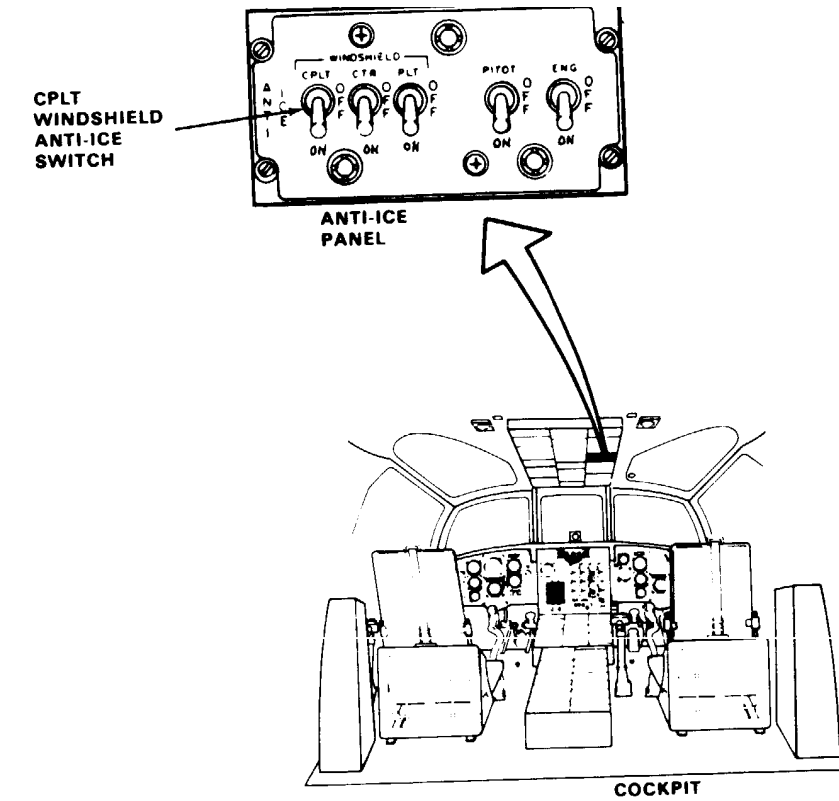
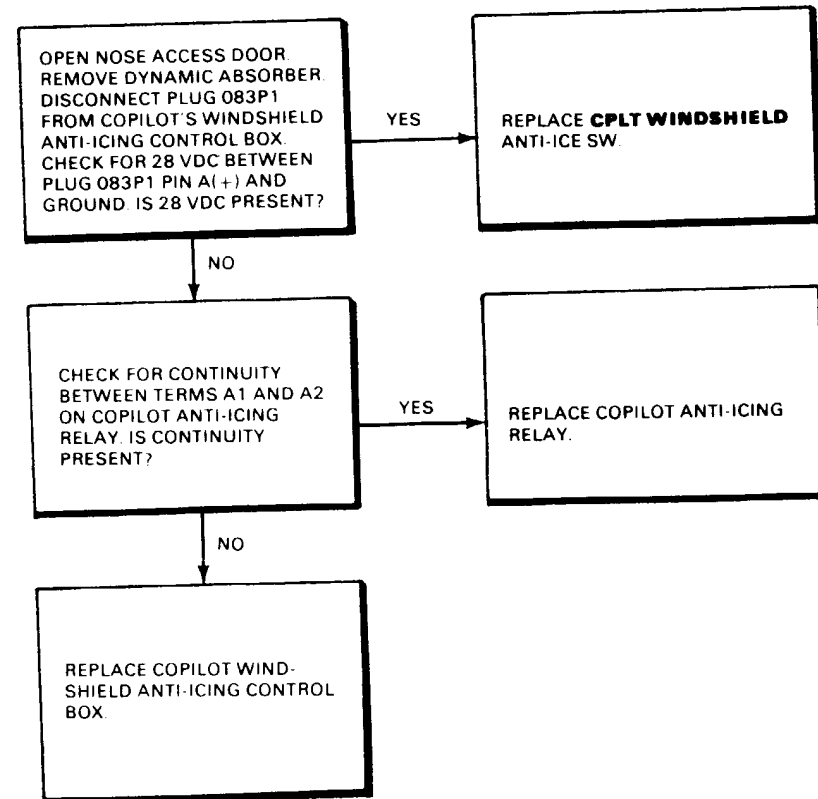

12-1.8 CTR WSHLD ANTI-ICE CONT CIRCUIT BREAKER WILL NOT STAY CLOSED

12-1.8

FAULT ISOLATION PROCEDURE

INITIAL SETUP

Personnel Required:
68F20 Aircraft Electrician

Applicable Configurations:
All

References:
TM 55-1520-240-23

Tools:
Electrical Repairer's Tool Kit,
NSN 5180-00-323-4915
Multimeter

Equipment Condition:
TM 55-1520-240-23:
Battery Disconnected
Electrical Power Off
Hydraulic Power Off

Materials:
None

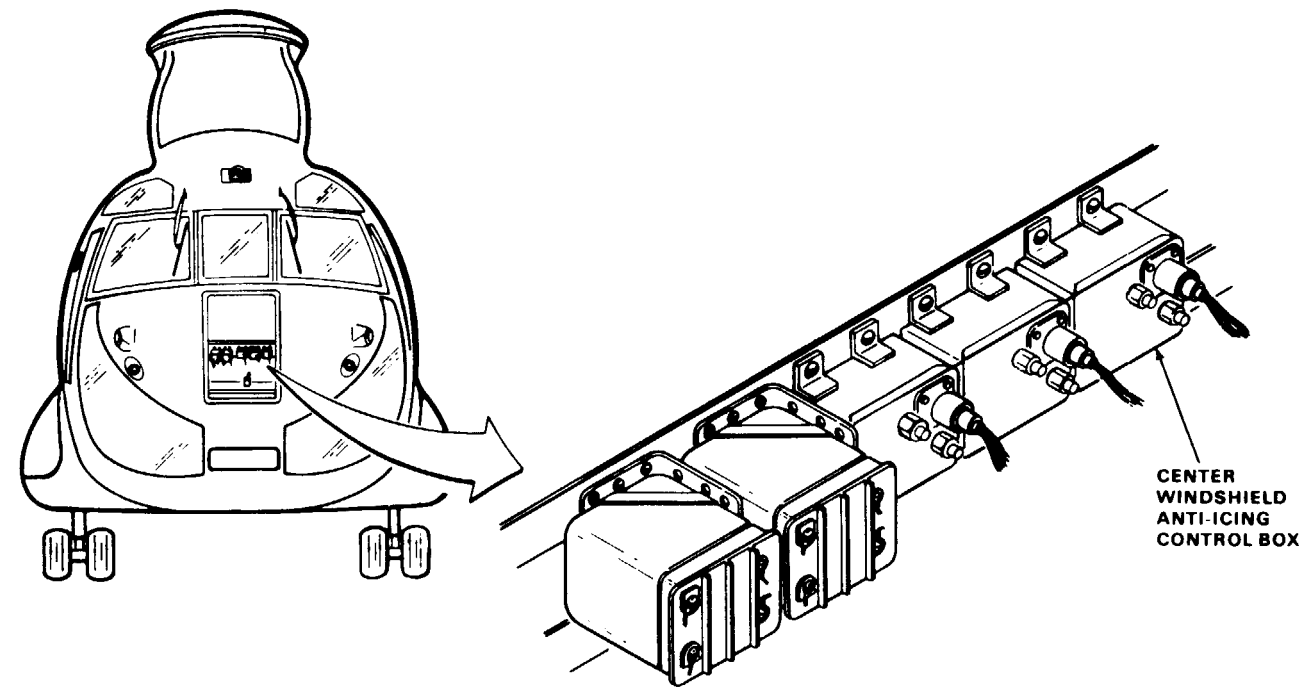
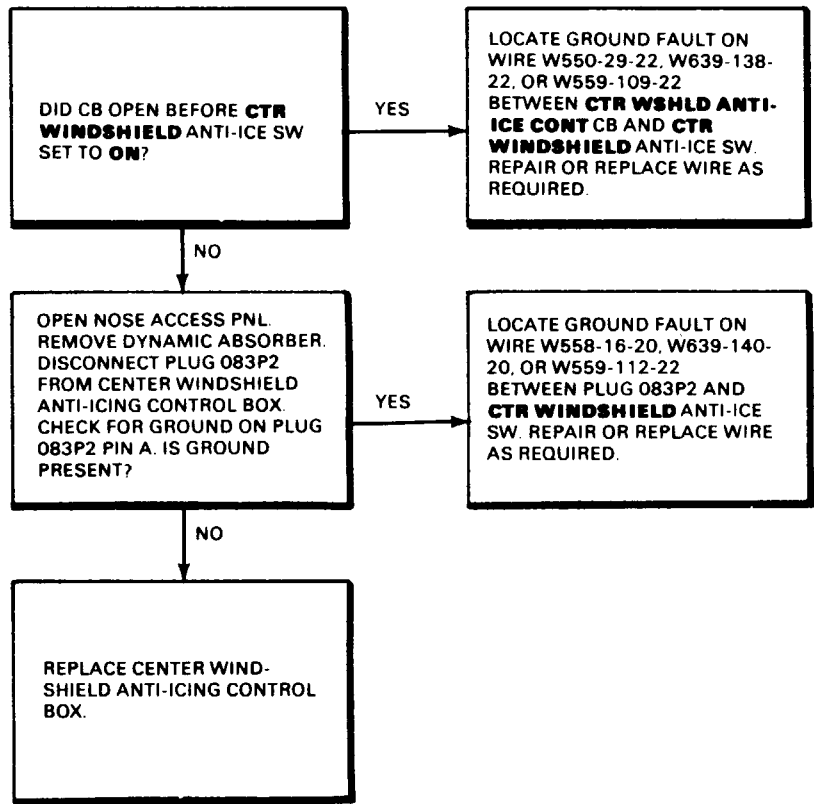
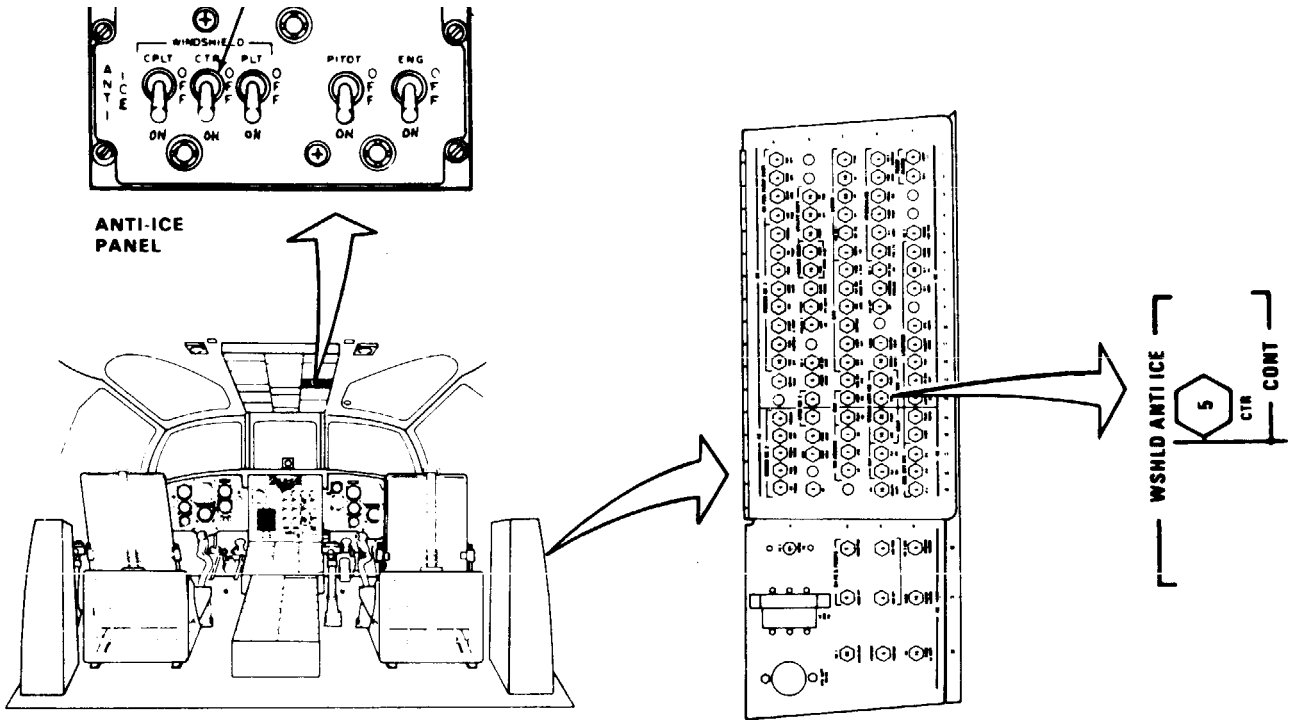

12-1.9 CTR WSHLD ANTI ICE HEAT CIRCUIT BREAKER WILL NOT STAY CLOSED

FAULT ISOLATION PROCEDURE

INITIAL SETUP

Personnel Required:
68F20 Aircraft Electrician

Applicable Configurations:
All

References:
TM 55-1520-240-23

Tools:
Electrical Repairer's Tool Kit,
NSN 5180-00-323-4915
Multimeter

Equipment Condition:
TM 55-1520-240-23:
Battery Disconnected
Electrical Power Off
Hydraulic Power Off

Materials:
None

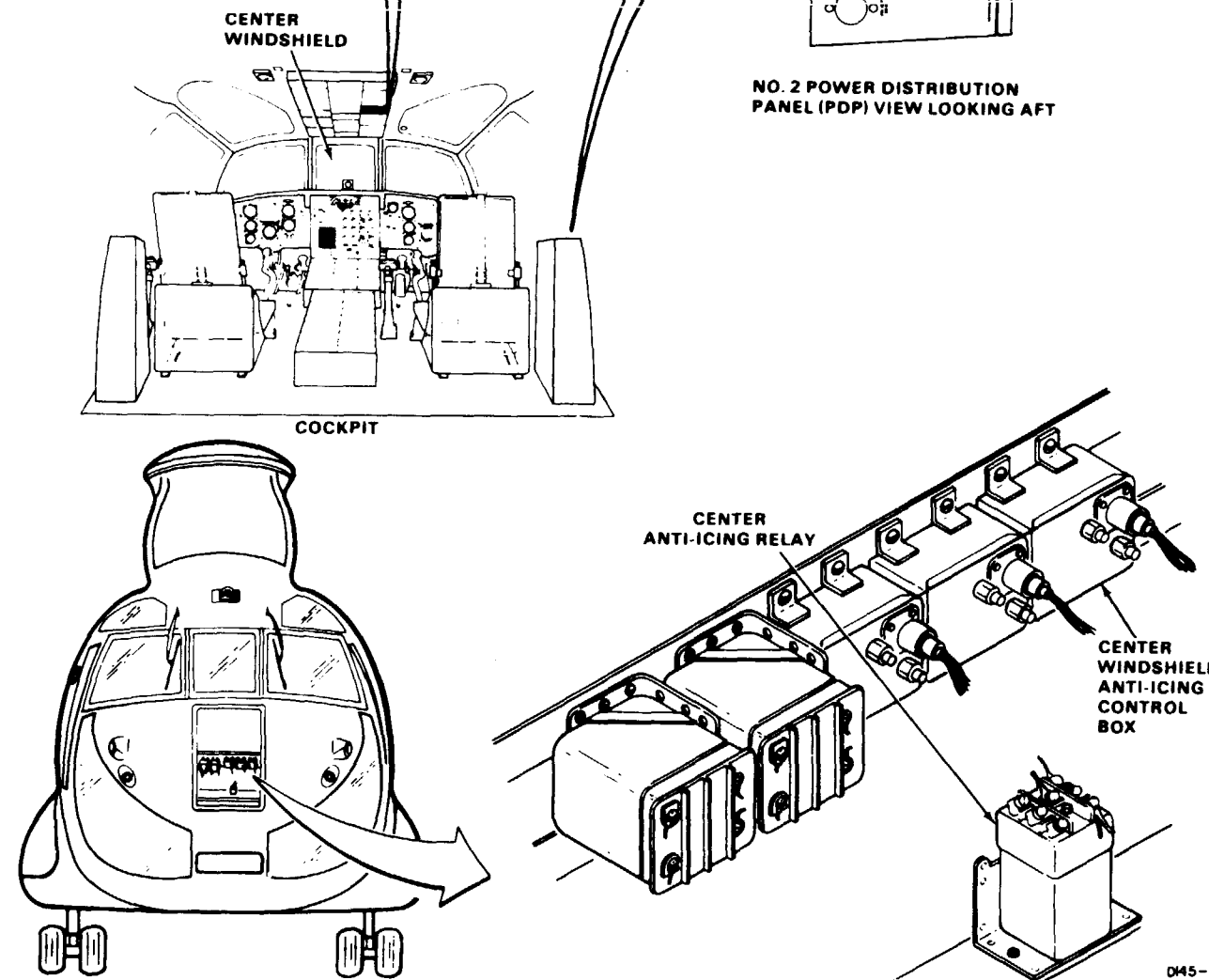
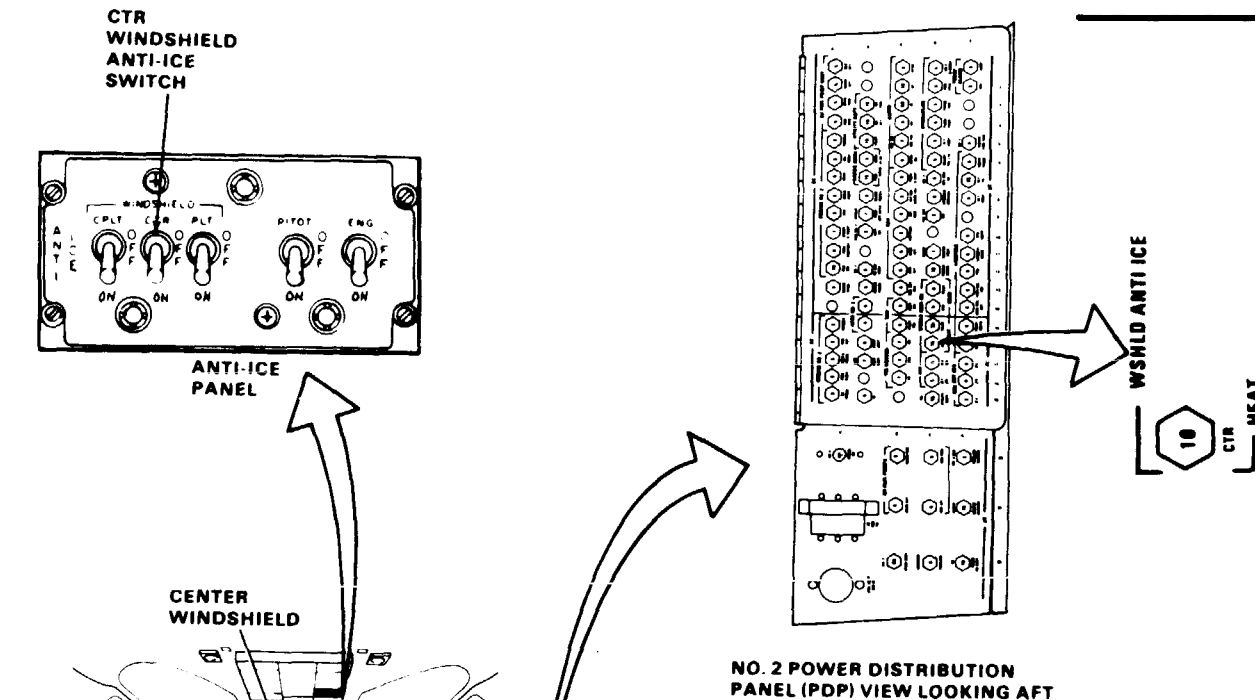
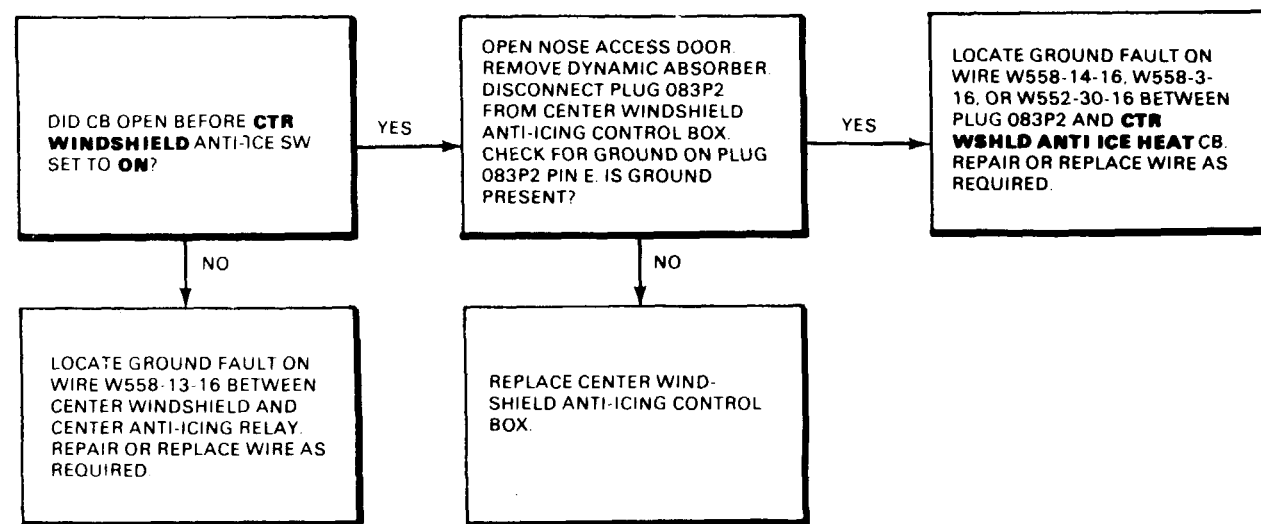

45x54

045-5376-SPA

END OF TASK

12-1.10 CENTER WINDSHIELD DOES NOT GET WARM

FAULT ISOLATION PROCEDURE

INITIAL SETUP

Applicable Configurations:
All

Tools:
Electrical Repairer's Tool Kit,
NSN 5180-00-323-4915
Multimeter

Materials:
None

Personnel Required:
68F10 Aircraft Electrician
68F20 Aircraft Electrician

References:
TM 55-1520-240-23

Equipment Condition:
TM 55-1520-240-23:
Battery Connected
Electrical Power On
Hydraulic Power Off

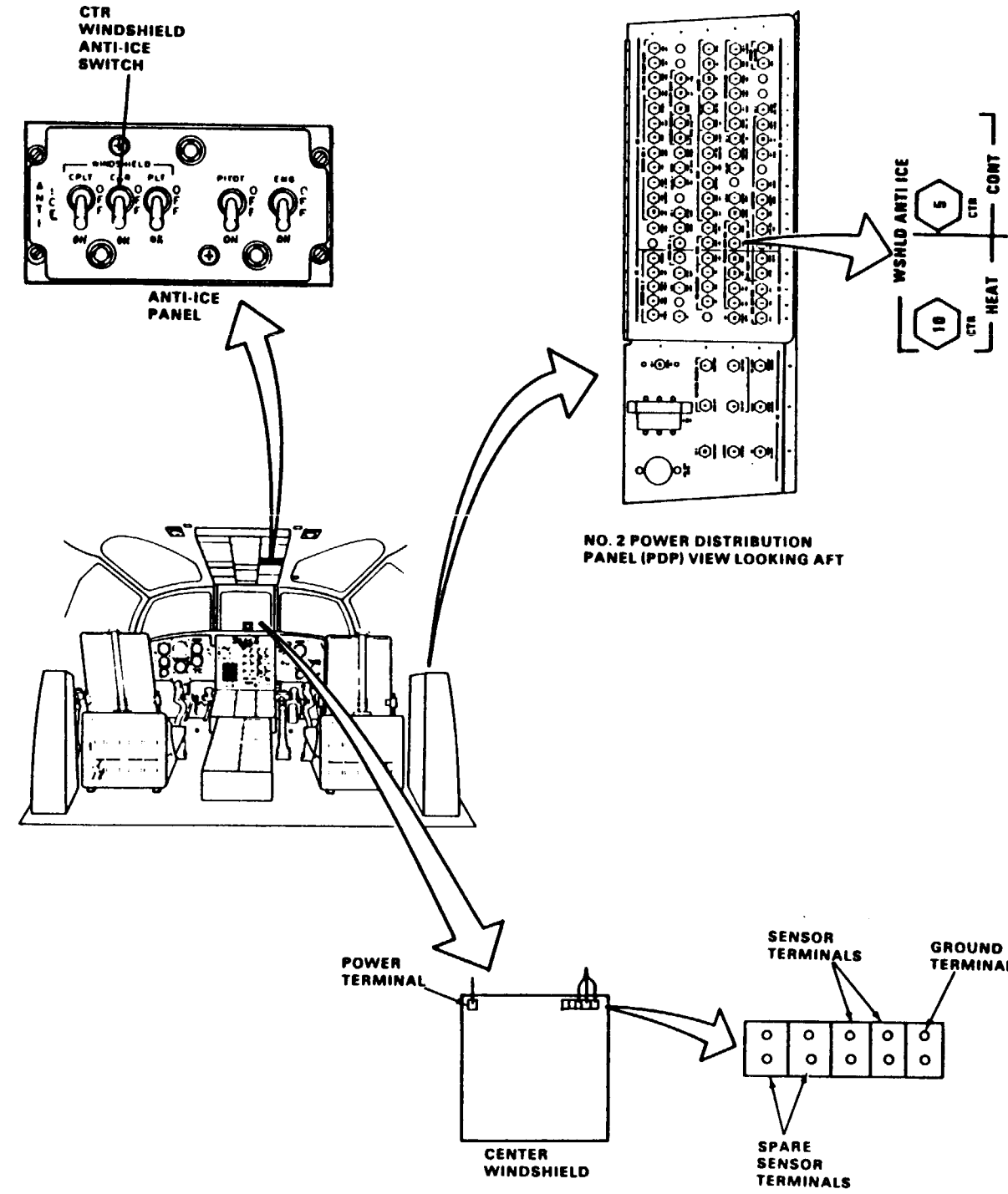
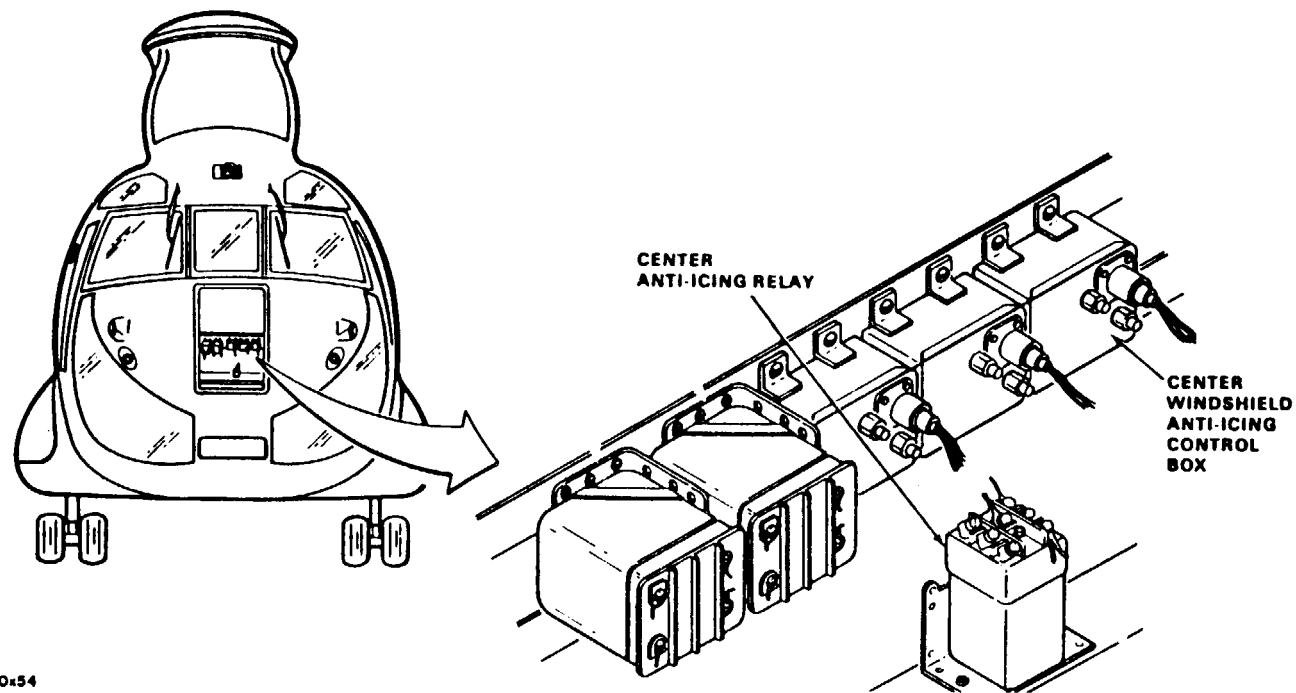

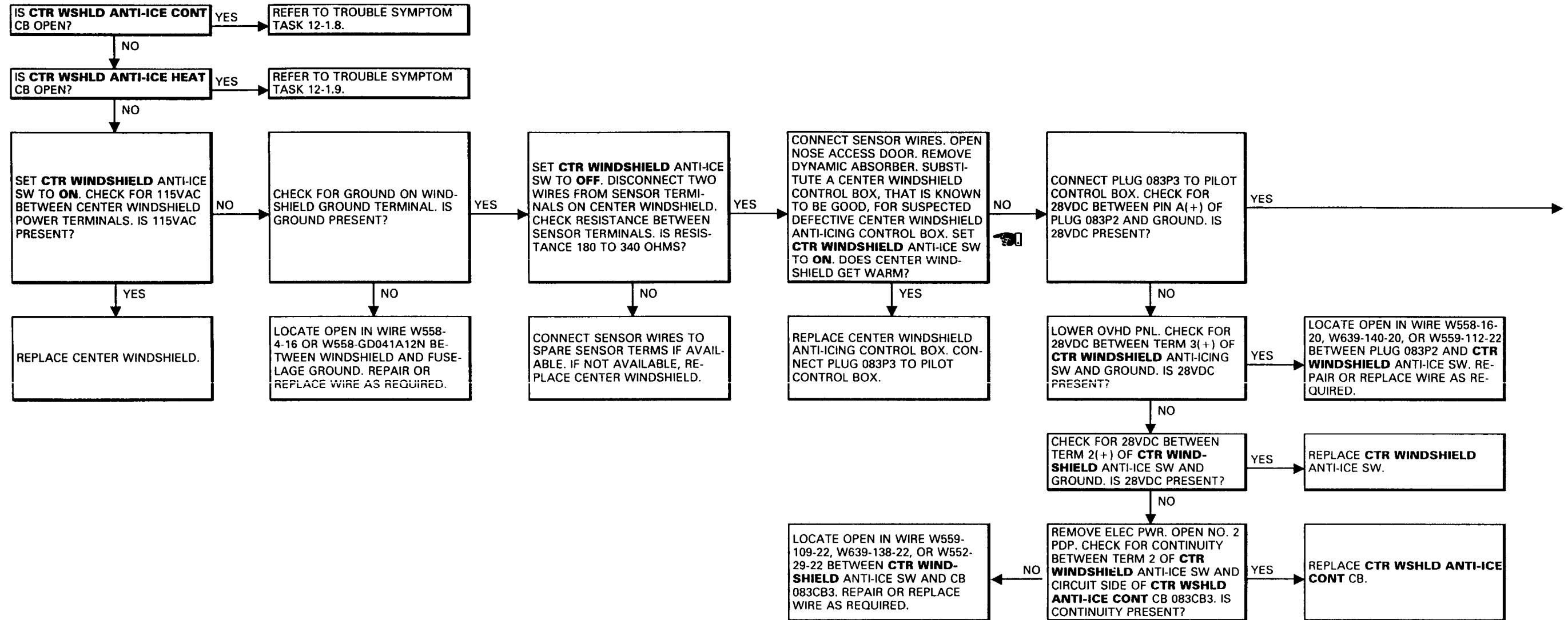

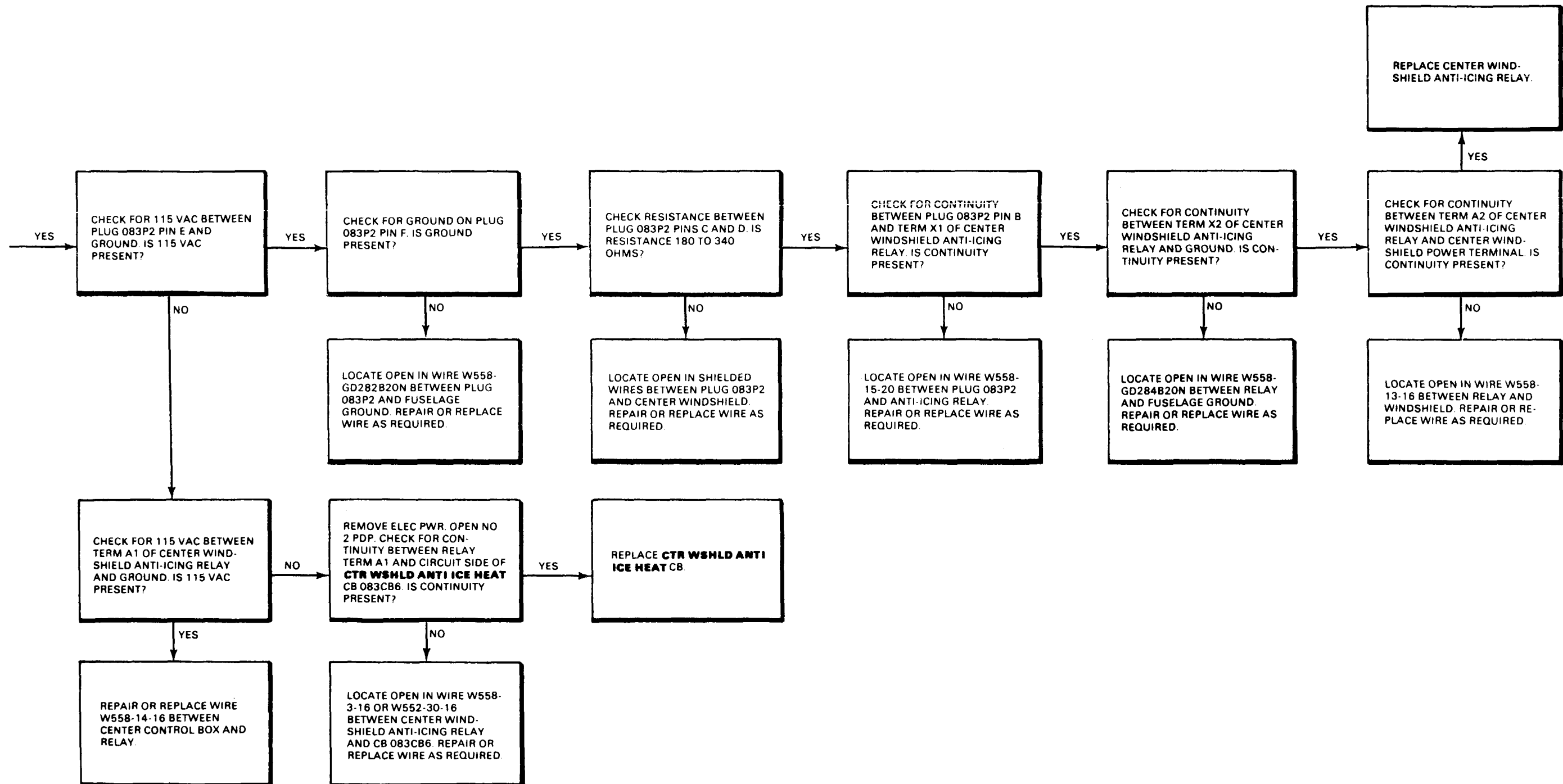

GO TO NEXT PAGE

12-1.10 CENTER WINDSHIELD DOES NOT GET WARM (Continued)

12-1.10

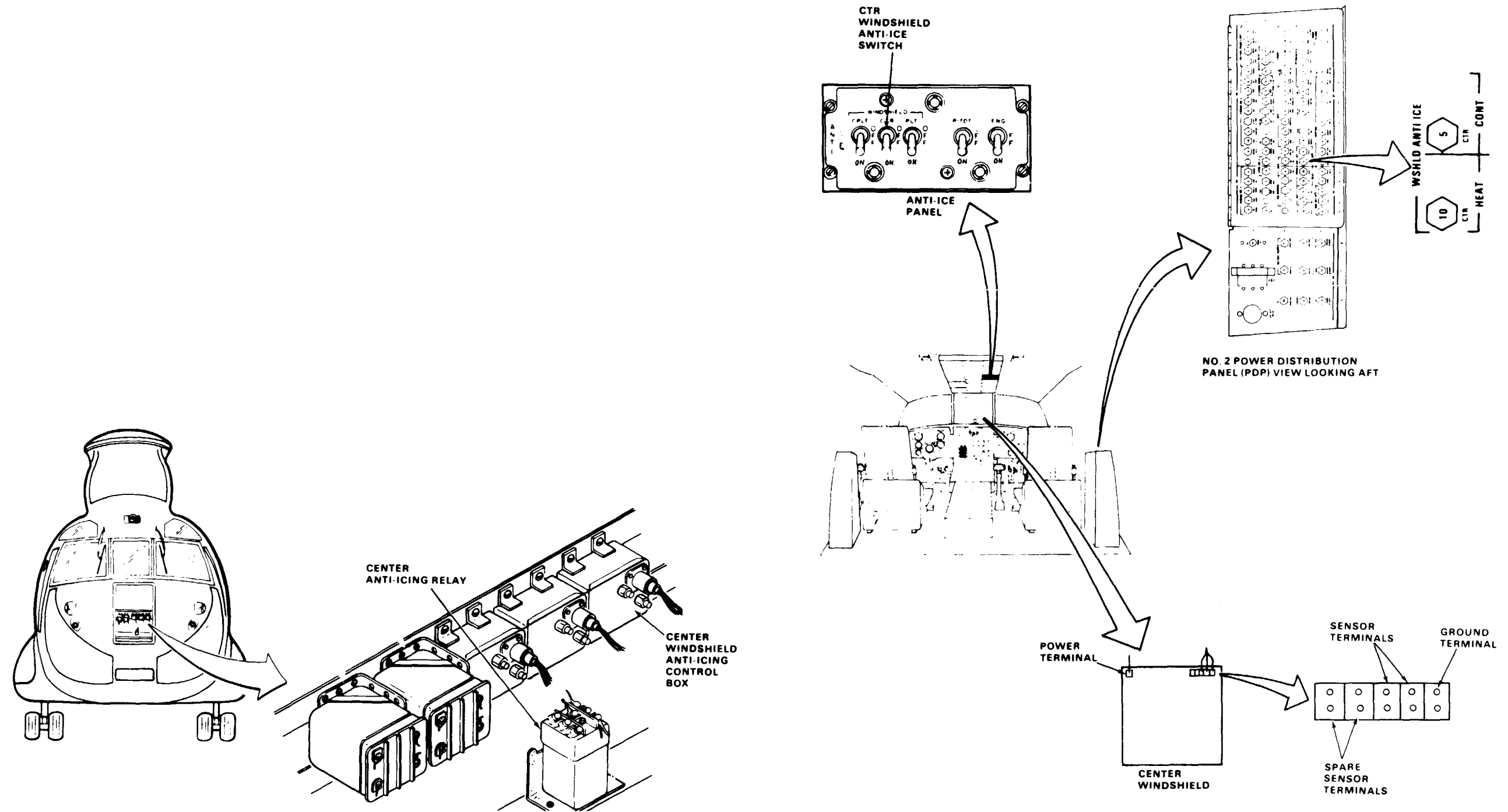

90x54

DI45-11826-SPA

END OF TASK

12-19

12-1.11 CENTER WINDSHIELD CONTINUES TO HEAT WHEN CTR WINDSHIELD SWITCH IS AT OFF

FAULT ISOLATION PROCEDURE

INITIAL SETUP

Applicable Configurations:

All

Tools:

- Electrical Repairer's Tool Kit,
NSN 5180-00-323-4915
- Multimeter

Materials:

None

Personnel Required:

68F20 Aircraft Electrician

References:

TM 55-1520-240-23

Equipment Condition:

TM 55-1520-240-23:

Battery Connected

Electrical Power On

Hydraulic Power Off

Nose Dynamic Absorber Removed

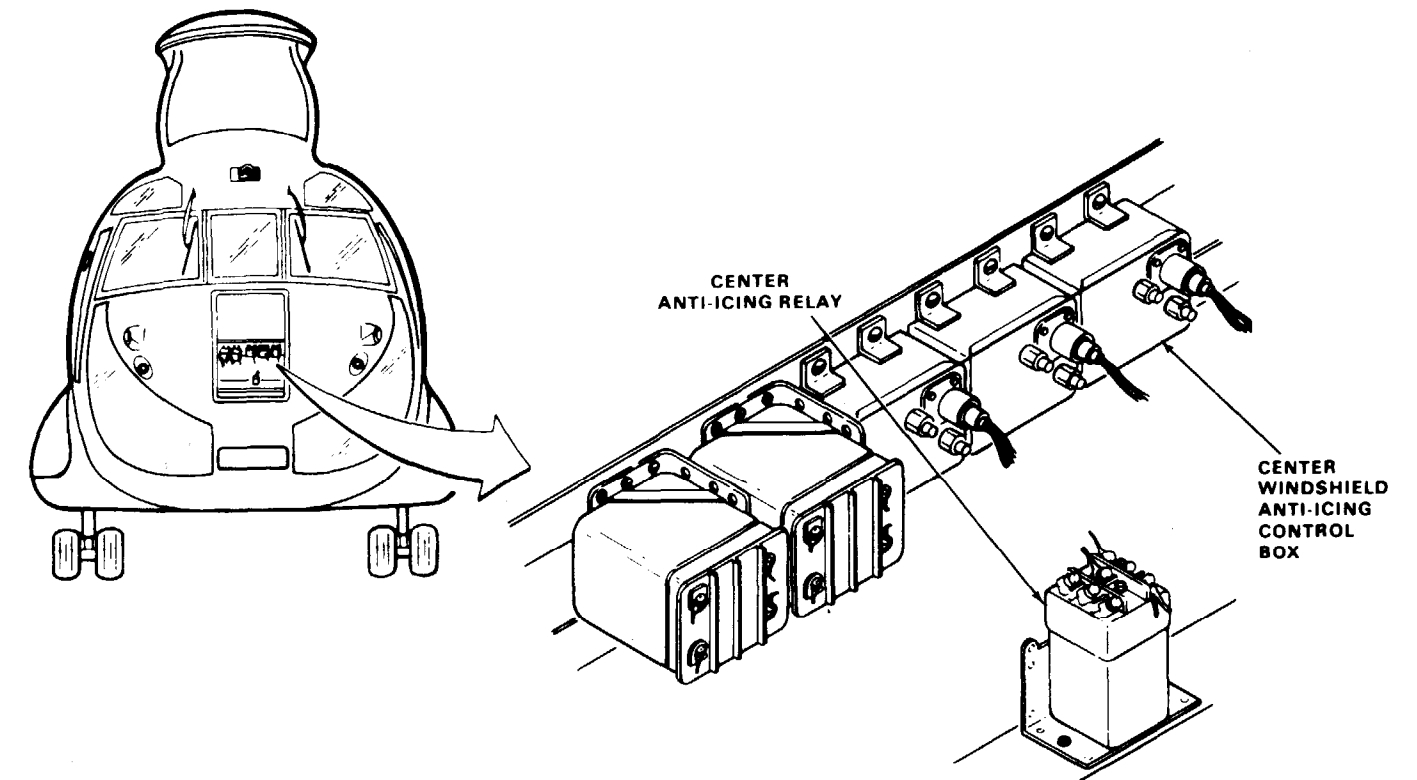
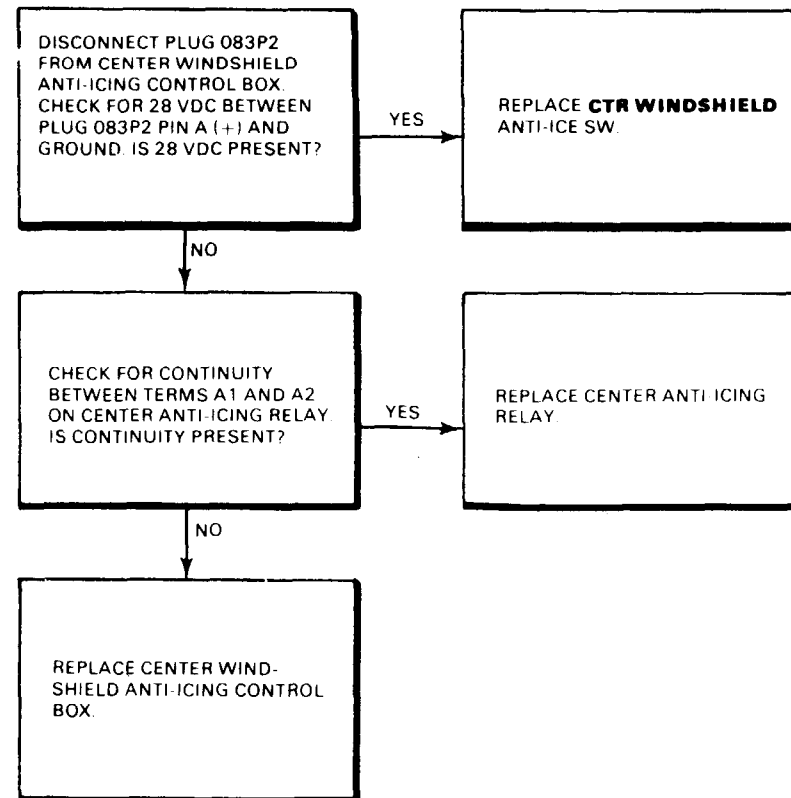
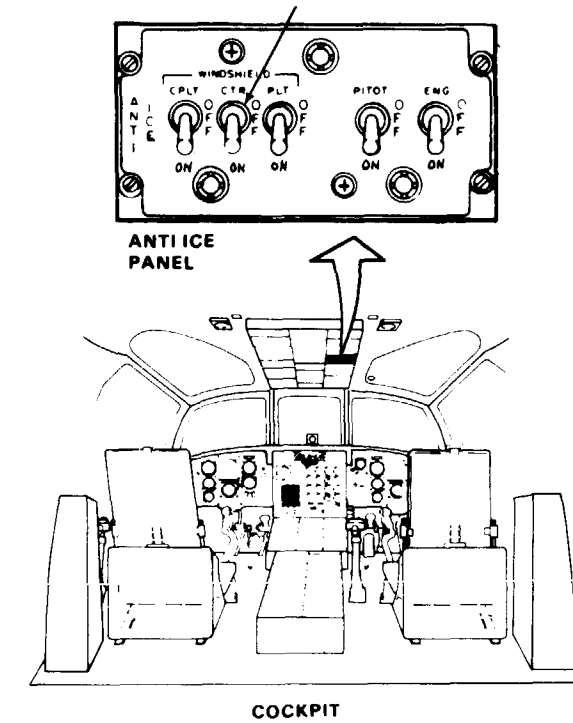

12-1.12 PILOT WSHLD ANTI ICE CONT CIRCUIT BREAKER WILL NOT STAY CLOSED

12-1.12

FAULT ISOLATION PROCEDURE

INITIAL SETUP

Applicable Configurations:
All

Tools:
Electrical Repairer's Tool Kit,
NSN 5180-00-323-4915
Multimeter

Materials:
None

Personnel Required:
68F20 Aircraft Electrician

References:
TM 55-1520-240-23

Equipment Condition:
TM 55-1520-240-23;
Battery Disconnected
Electrical Power Off
Hydraulic Power Off

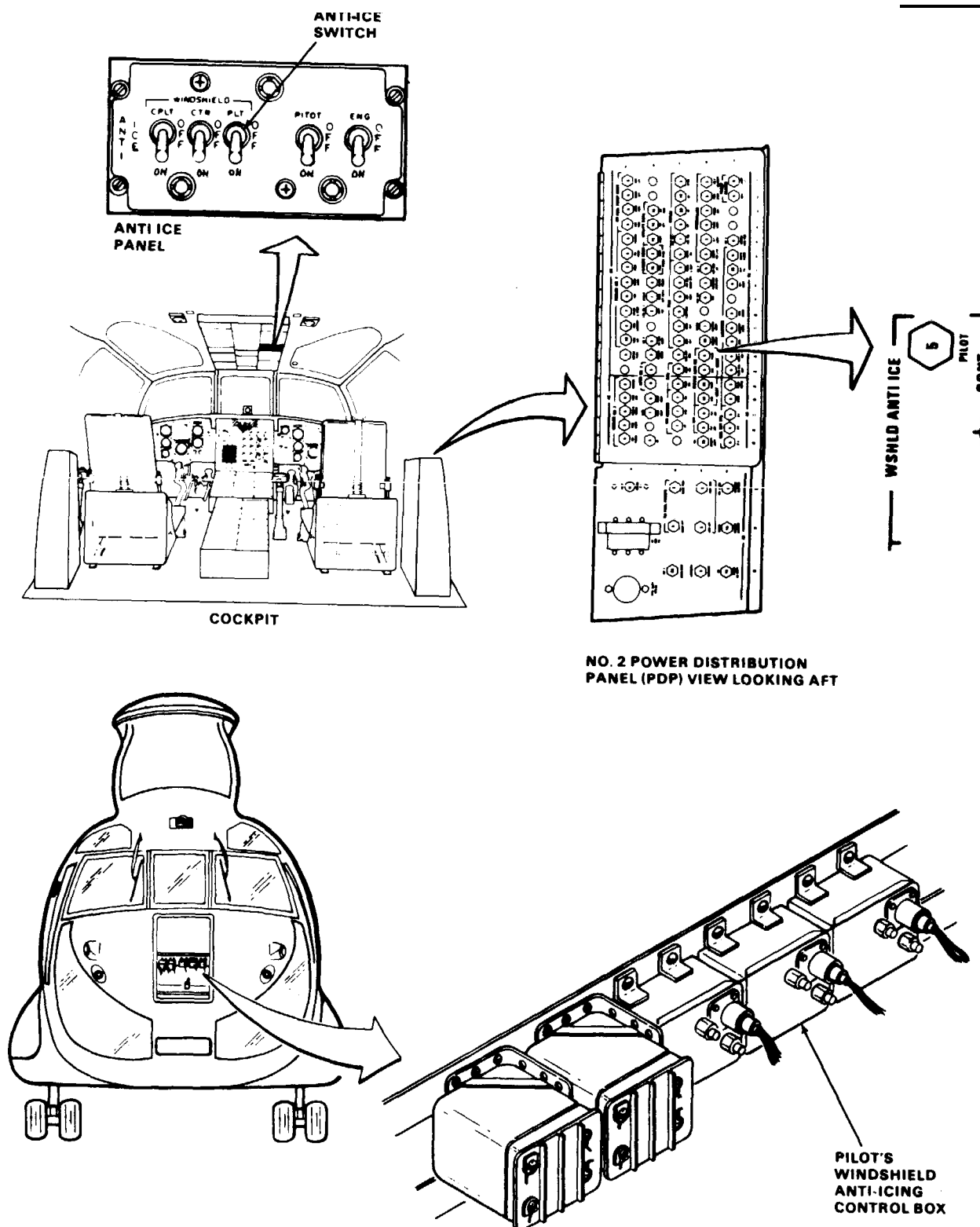
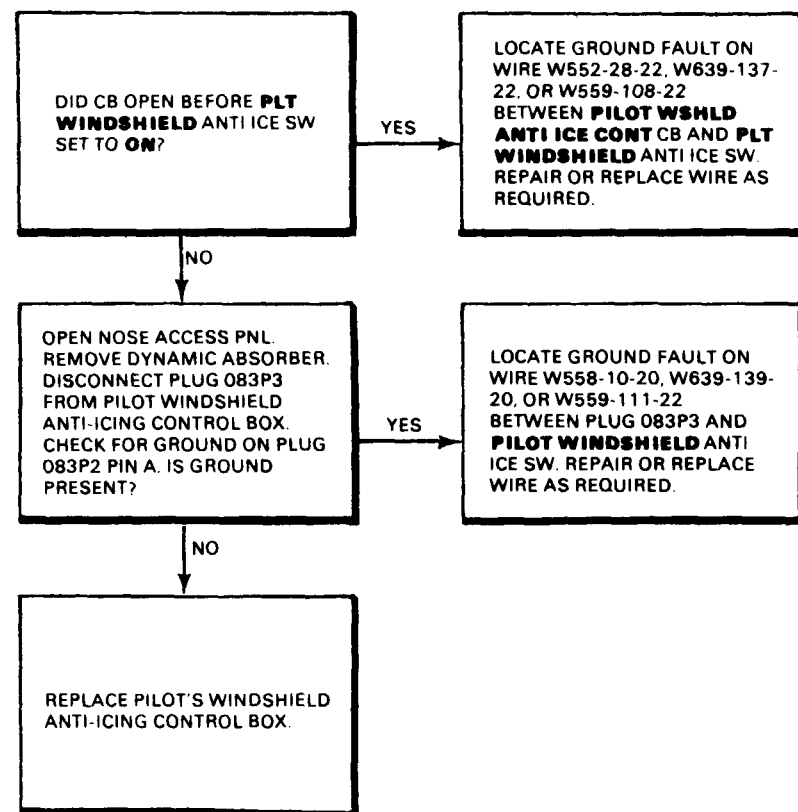

45x54

DI45-5379-SPA

END OF TASK

12-1.13 PILOT WSHLD ANTI ICE HEAT CIRCUIT BREAKER
WILL NOT STAY CLOSED

FAULT ISOLATION PROCEDURE

INITIAL SETUP

Applicable Configurations:
All

Tools:
Electrical Repairer's Tool Kit,
NSN 5180-00-323-4915
Multimeter

Materials:
Note

Personnel Required:
68F20 Aircraft Electrician

References:
TM 55-1520-240-23

Equipment Condition:
TM 55-1520-240-23:
Battery Disconnected
Electrical Power Off
Hydraulic Power Off

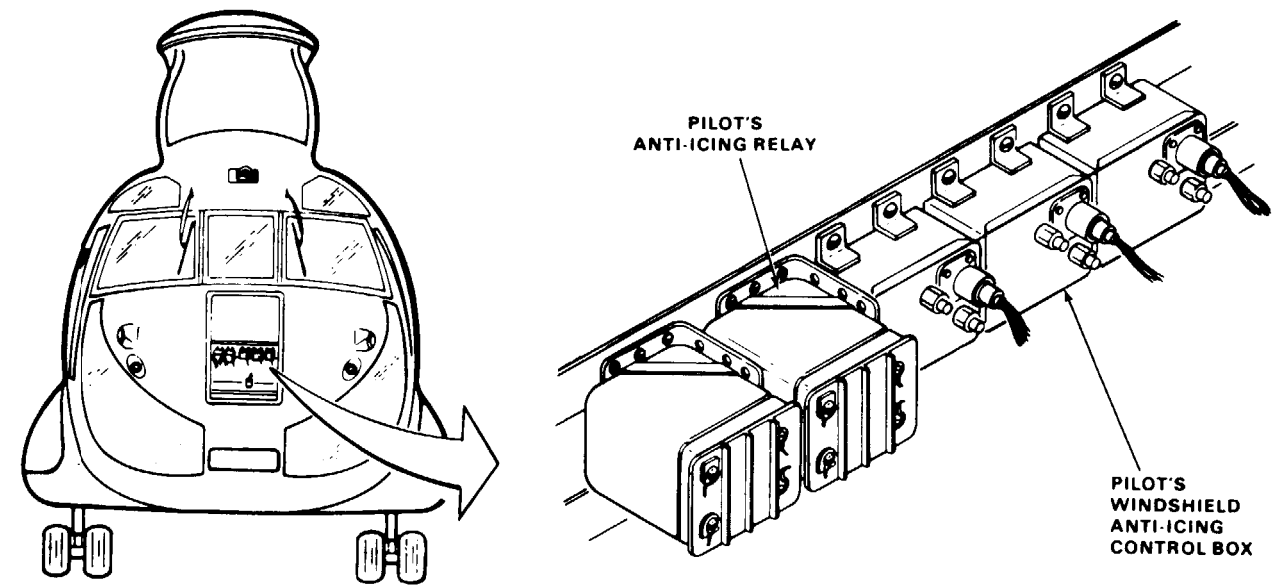
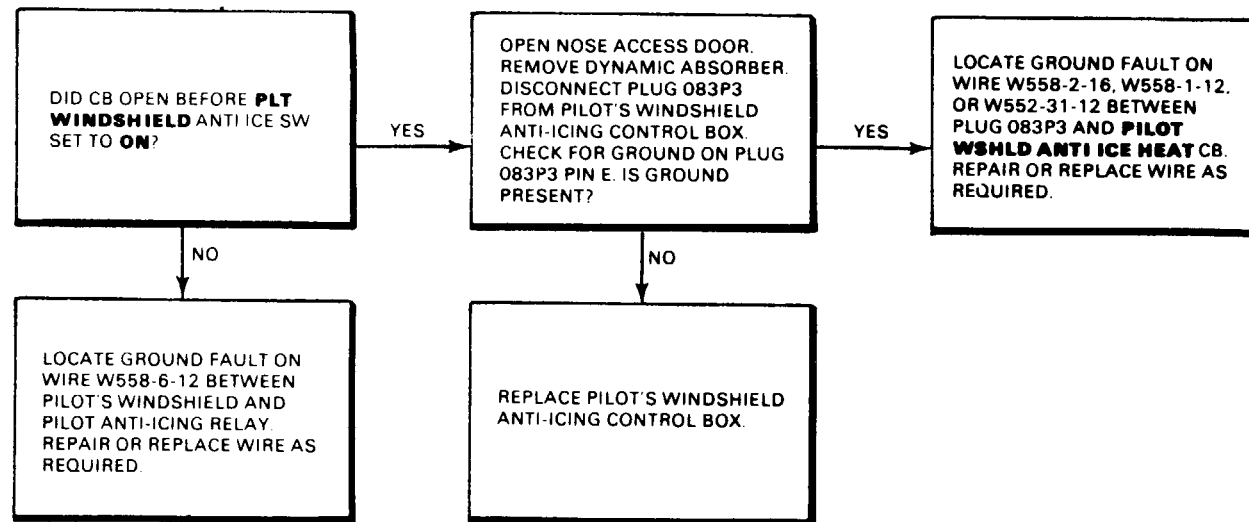
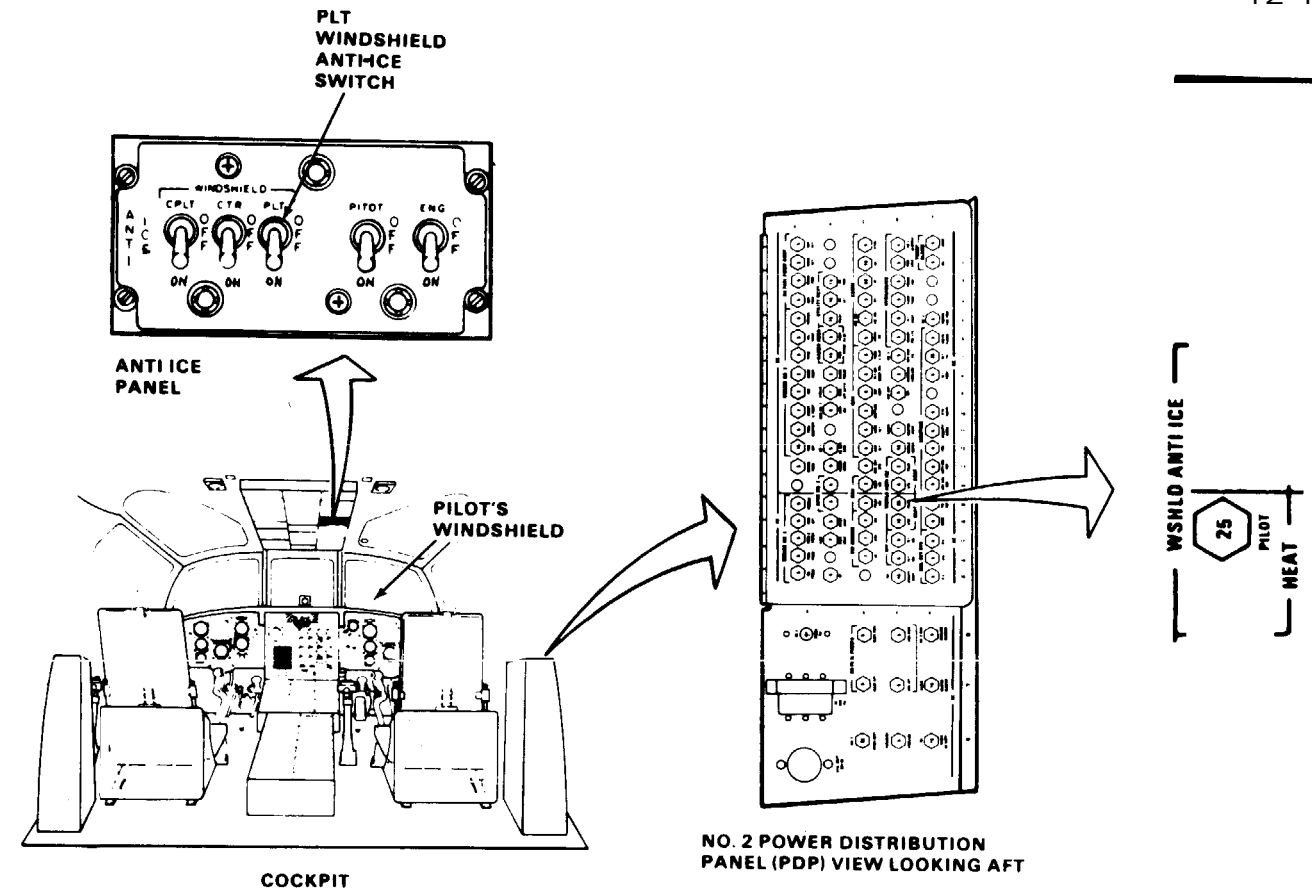

FAULT ISOLATION PROCEDURE

INITIAL SETUP

Applicable Configurations:
All

Tools:
Electrical Repairer's Tool Kit,
NSN 5180-00-323-4915
Multimeter

Materials:
None

Personnel Required:
68F10 Aircraft Electrician
68F20 Aircraft Electrician

References:
TM 55-1520-240-23

Equipment Condition:
TM 55-1520-240-23:
Battery Connected
Electrical Power On
Hydraulic Power Off

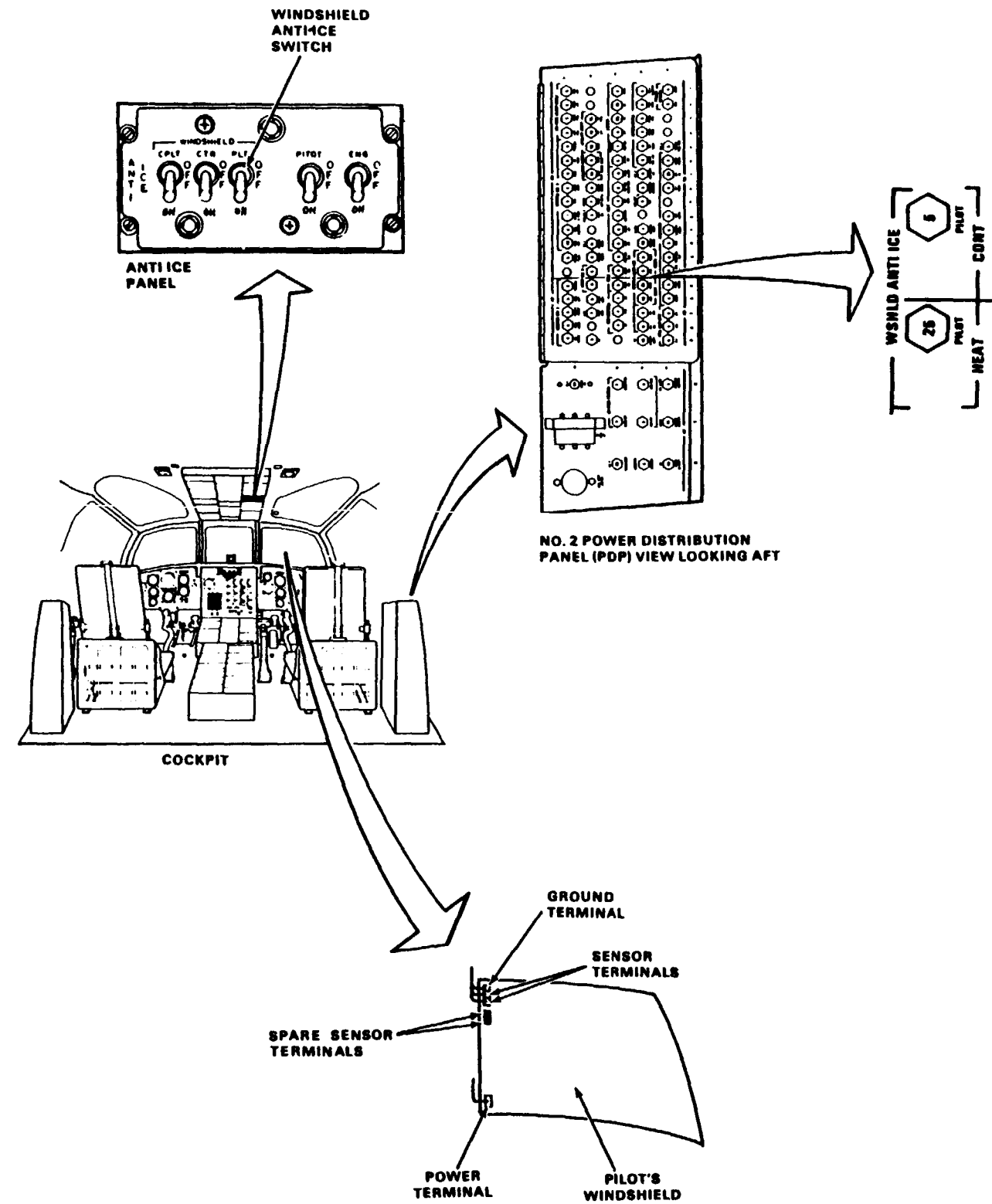
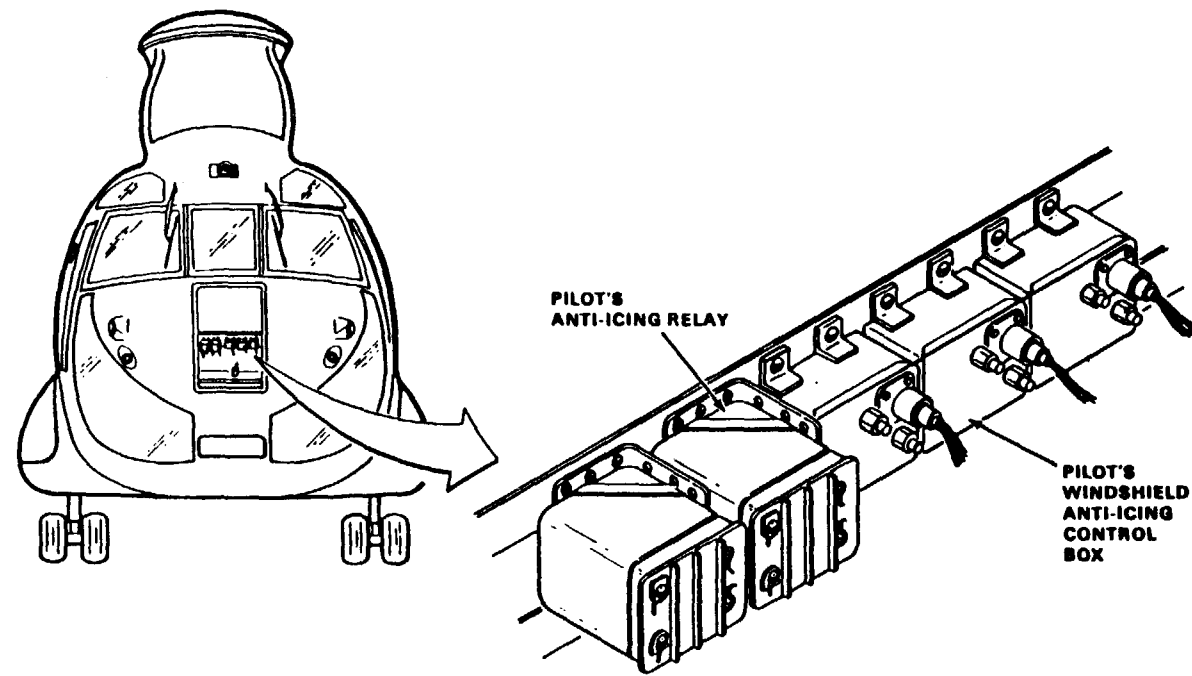

12-1.14 PILOT'S WINDSHIELD DOES NOT GET WARM (Continued)

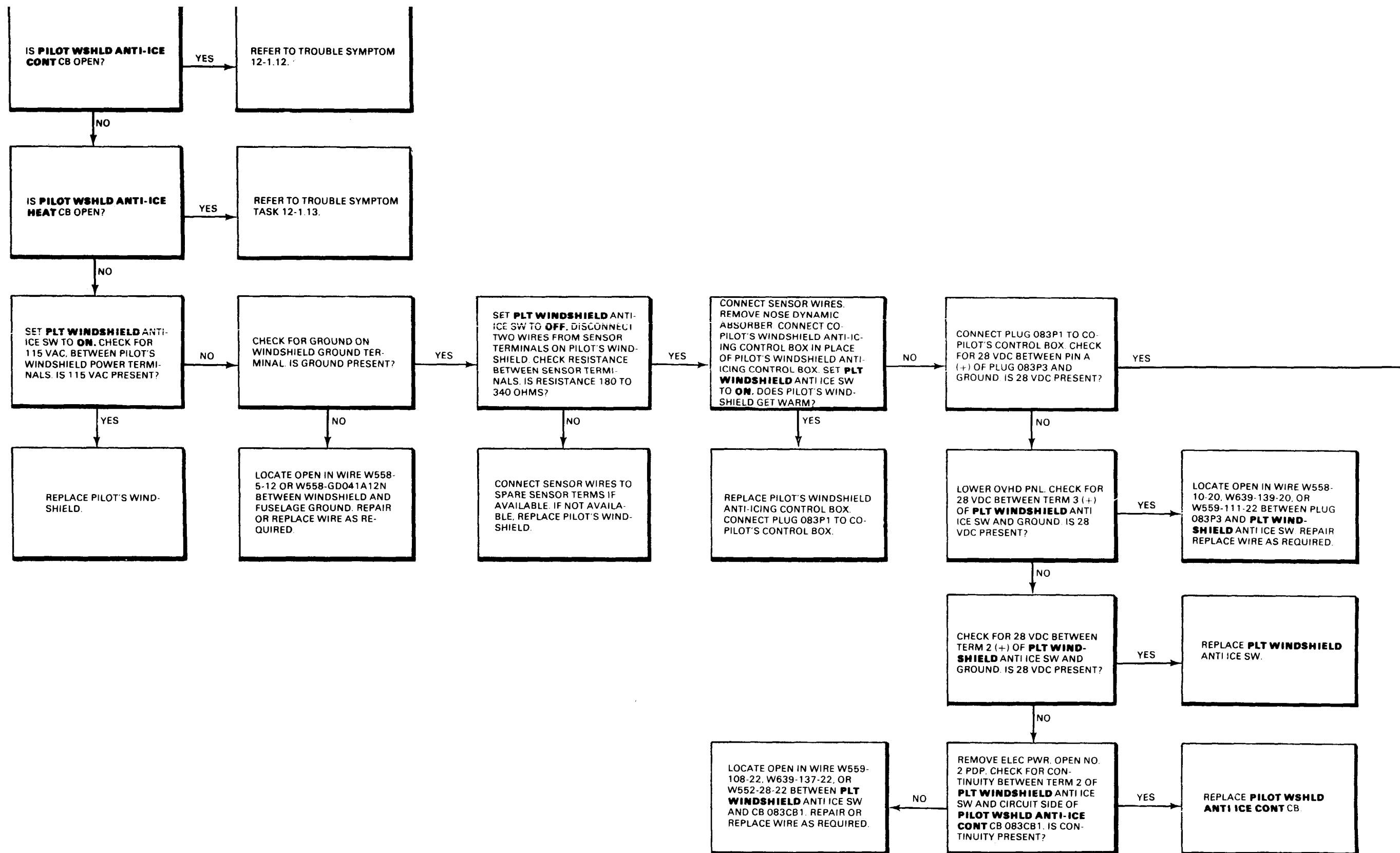

GO TO NEXT PAGE

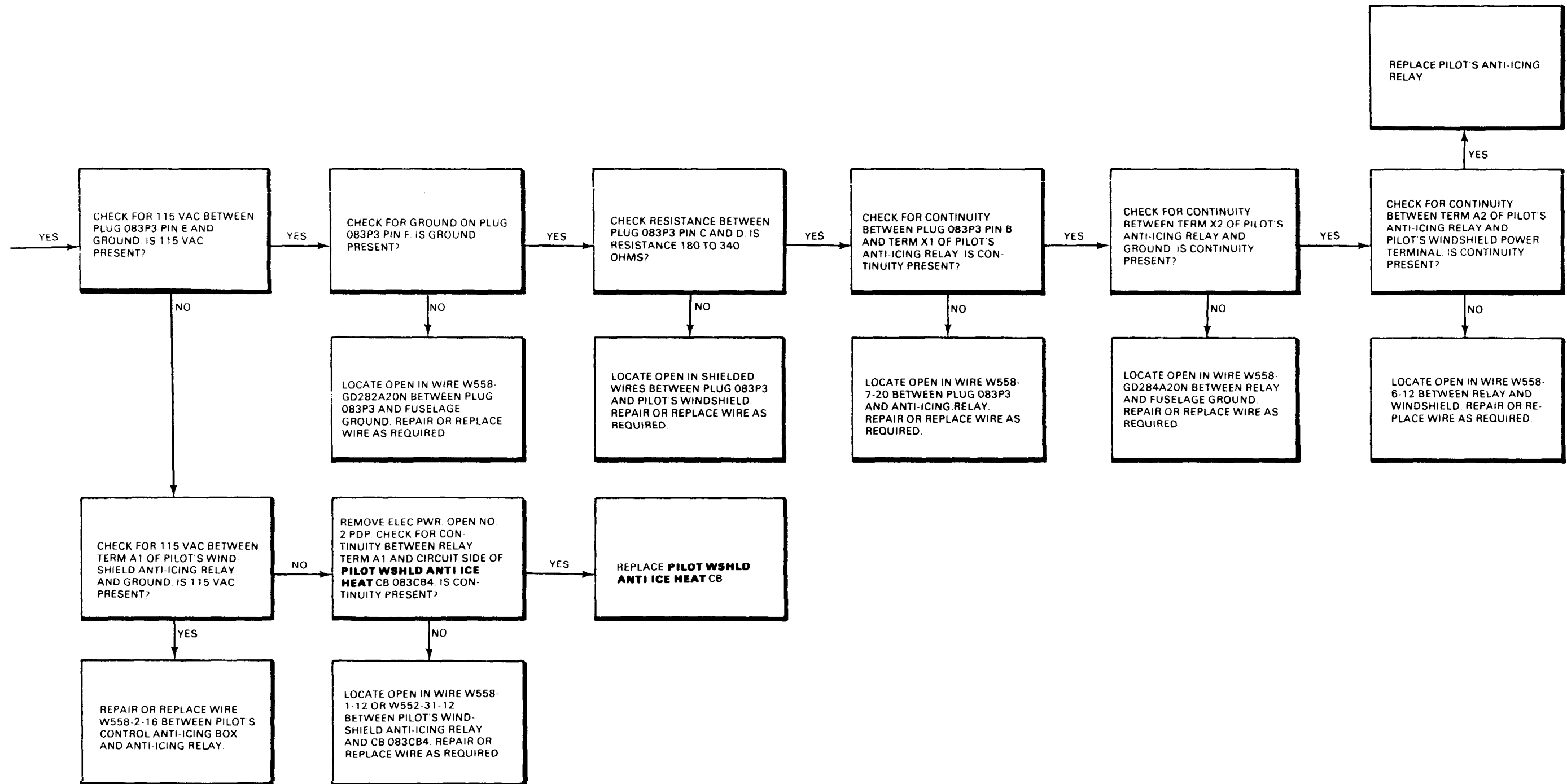

GO TO NEXT PAGE

12-1.14 PILOT'S WINDSHIELD DOES NOT GET WARM (Continued)

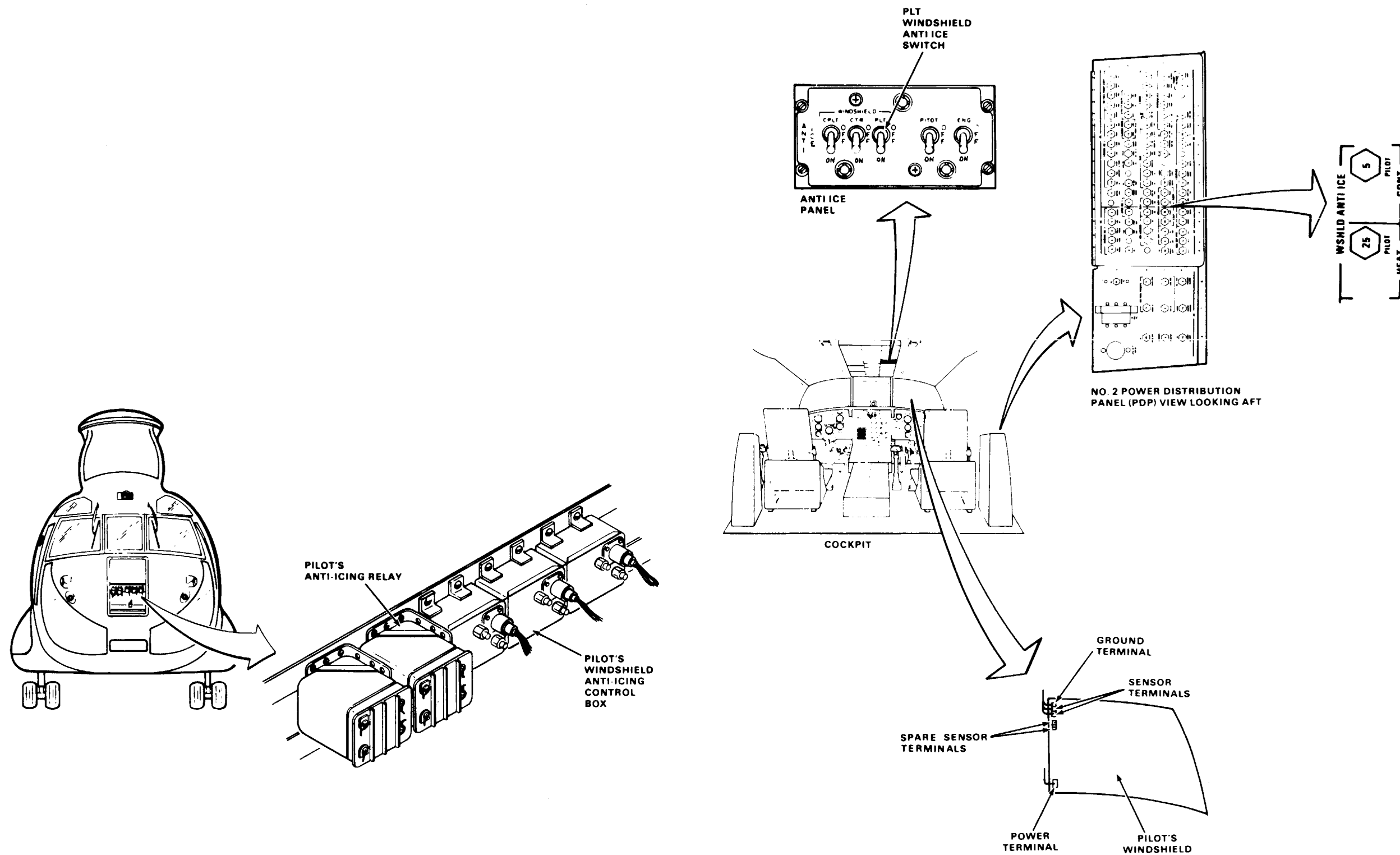

12-1.15 PILOT'S WINDSHIELD CONTINUES TO HEAT WHEN PLT WINDSHIELD SWITCH IS AT OFF

FAULT ISOLATION PROCEDURE

INITIAL SETUP

Applicable Configurations:
All

Tools:

Electrical Repairer's Tool Kit,
NSN 5180-00-323-4915
Multimeter

Materials:

None

Personnel Required:
68F20 Aircraft Electrician

References:
TM 55-1520-240-23

Equipment Condition:
TM 55-1520-240-23:
Battery Connected
Electrical Power On
Hydraulic Power Off
Nose Dynamic Absorber Removed

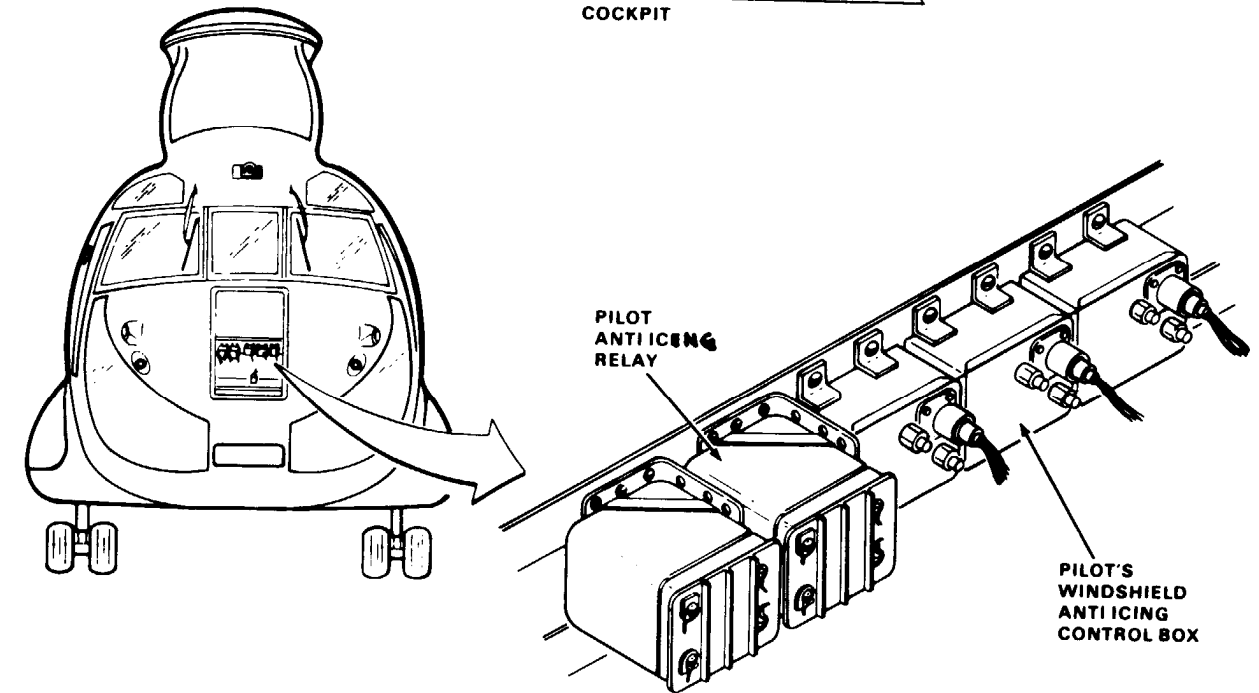
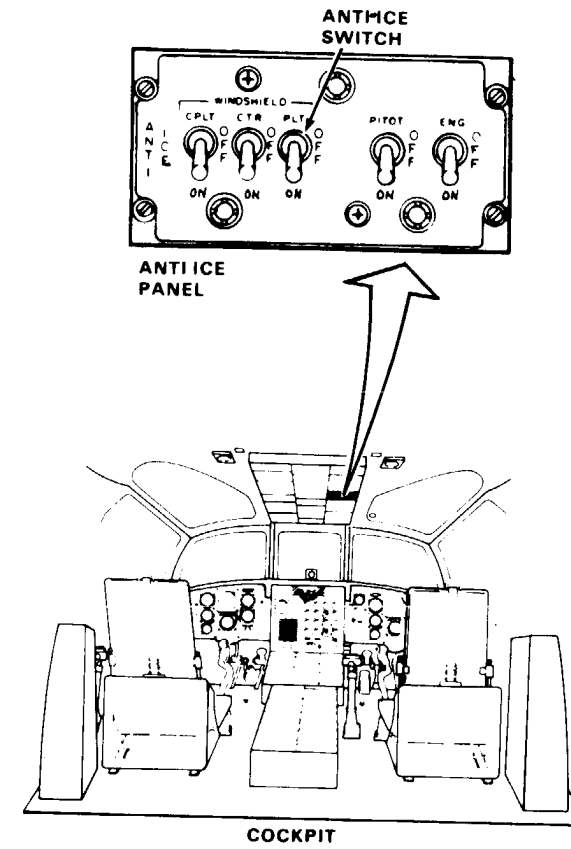
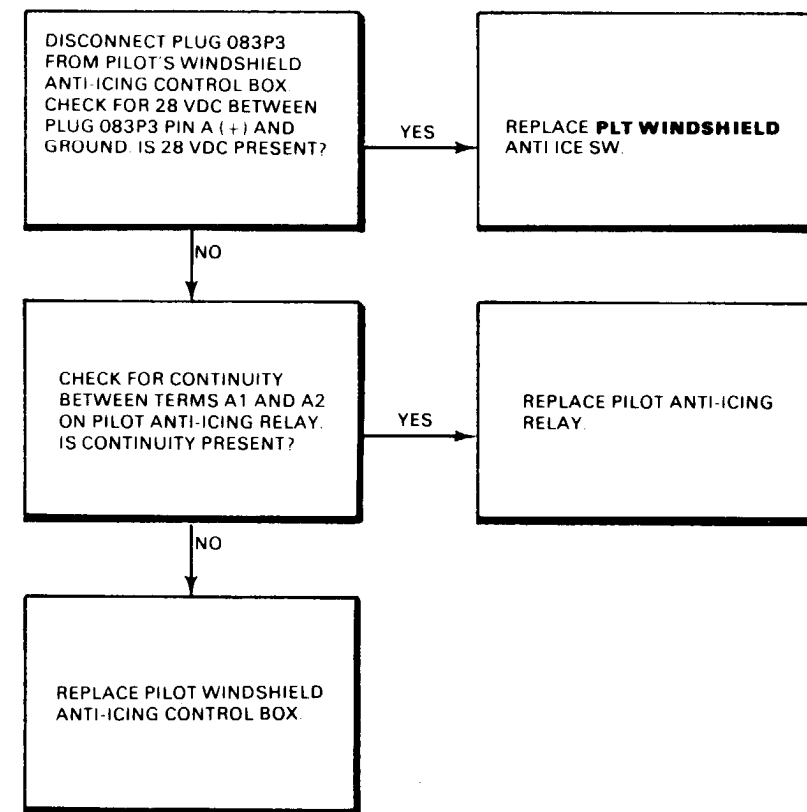

12-2 FIRE DETECTION SYSTEM

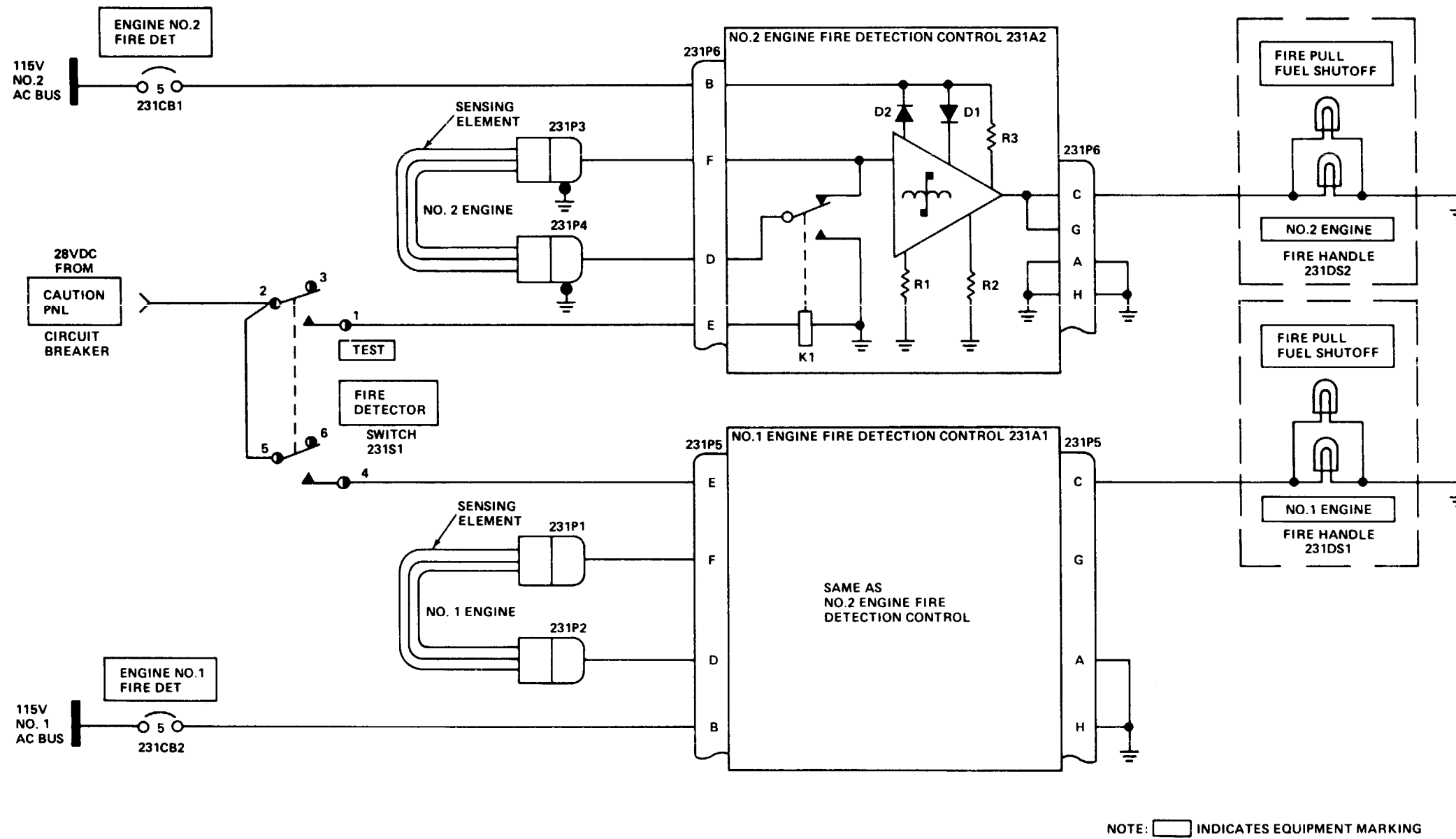

12-2.2 FIRE DETECTION SYSTEM WIRING DIAGRAM

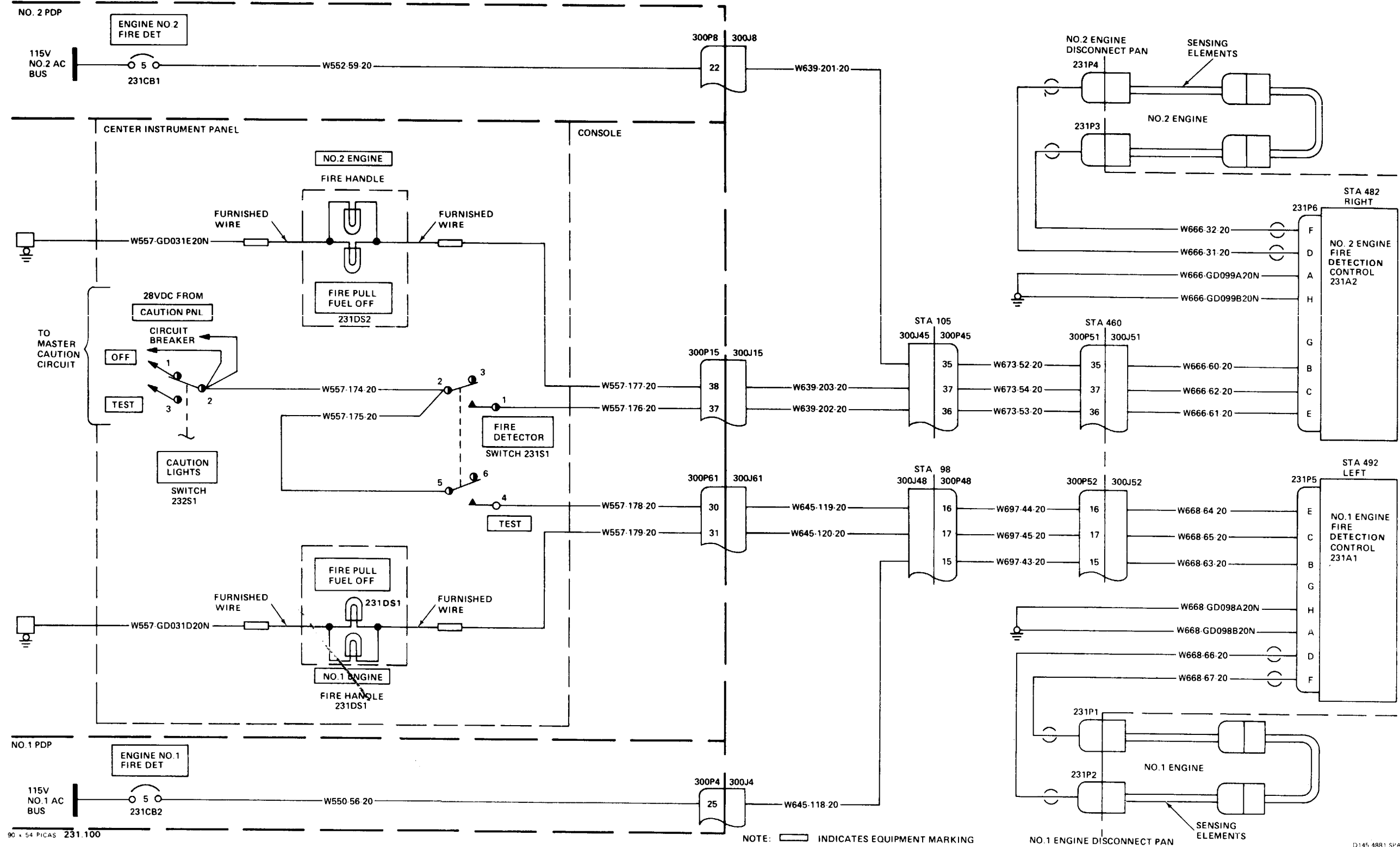

90 x 54 PICAS 231.100

NOTE: INDICATES EQUIPMENT MARKING

D145 4881 SPA

12-2.3 FIRE DETECTION SYSTEM VISUAL CHECK

INITIAL SETUP

Personnel Required:
68F10 Aircraft Electrician

Applicable Configurations:
All

References:
TM 55-1520-240-23

Tools:
Electrical Repairer's Tool Kit,
NSN 5180-00-323-4915

Equipment Condition:
TM 55-1520-240-23.
Battery Disconnected
Electrical Power Off
Hydraulic Power Off
No. 1 and No. 2 Engine
Access Covers Open

Materials:
None

1. Check Fire Detector switch (1).
2. Check No. 1 engine and No. 2 engine fire handles (2).
3. Check No. 1 and No. 2 engine fire detection controls (4).
4. Check sensing elements (5) around No. 1 engine.
5. Check sensing elements (7) around No. 2 engine.

If switch (1) is loose or damaged, tighten or replace it as required.

If either fire handle (2) is loose or damaged, tighten or replace it as required. If any light (3) is loose or damaged, tighten or replace it as required.

If either control (4) is loose or damaged, tighten or replace it as required. If wiring to either control is damaged, repair or replace it as required.

If any element (5) is damaged or kinked, replace it. If element connector (6) is loose, tighten it.

If any element (7) is damaged or kinked, replace it. If any element connector (6) is loose, tighten it.

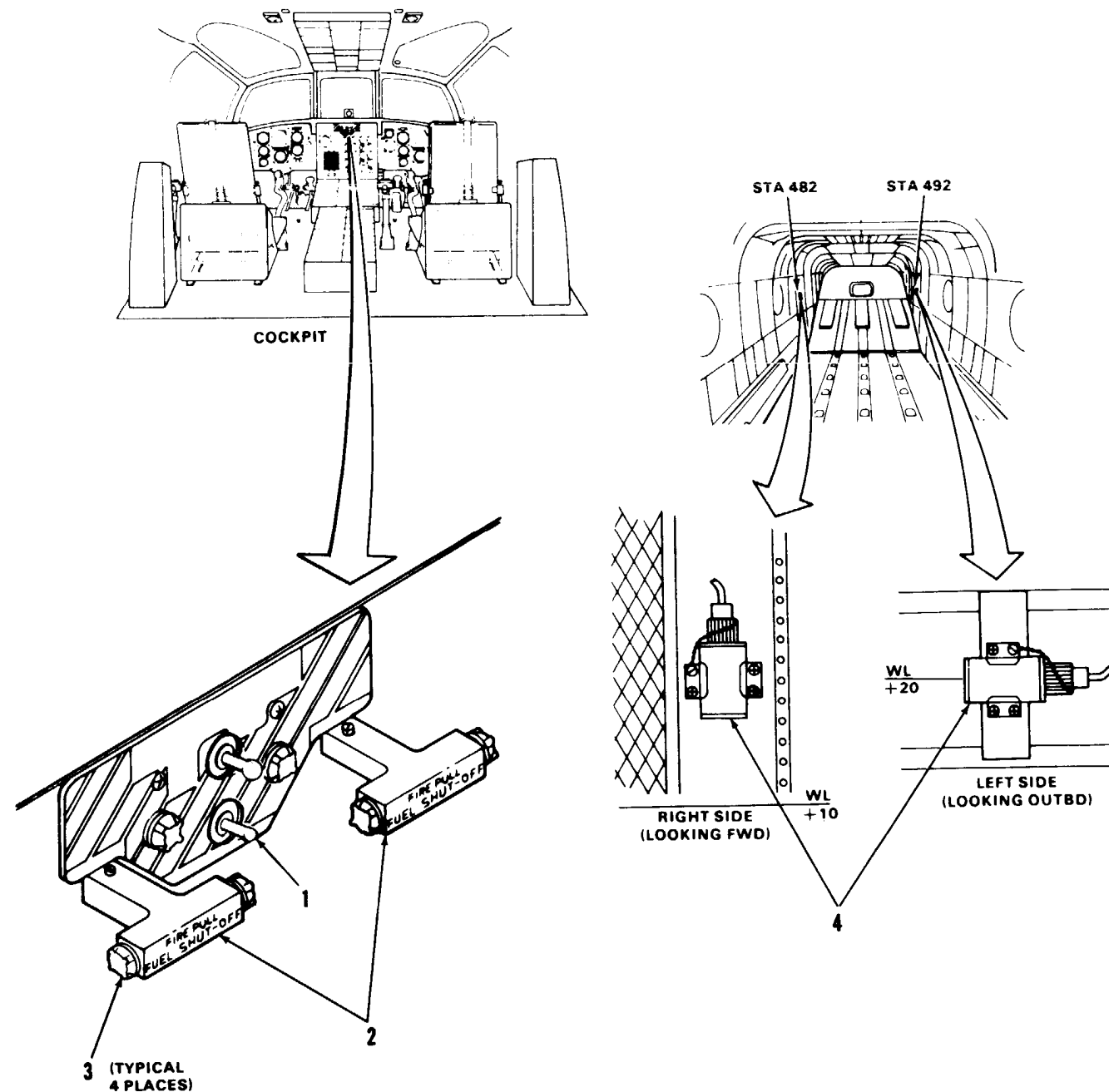

FOLLOW-ON MAINTENANCE:

TM 55-1520-240-23:
Close No. 1 and No. 2 engine access covers.

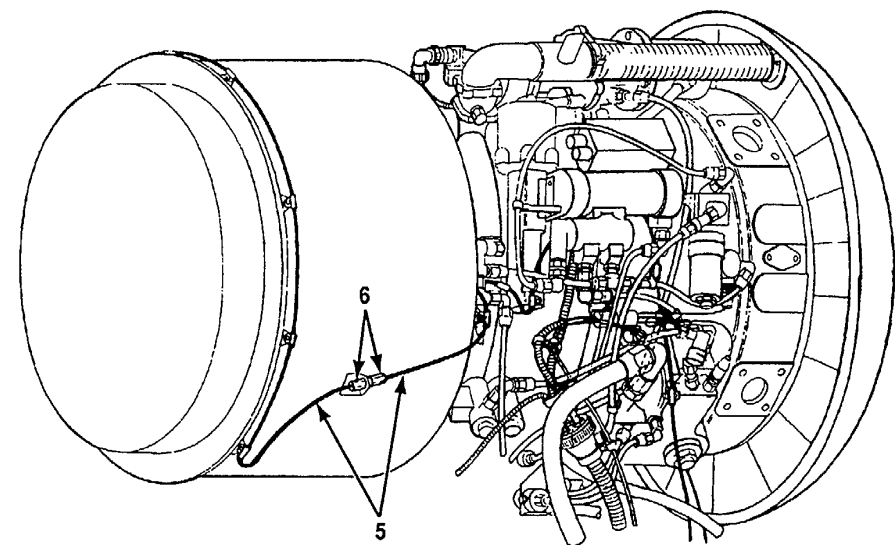

NO. 1 (LEFT) ENGINE-R SIDE

WITHOUT 74

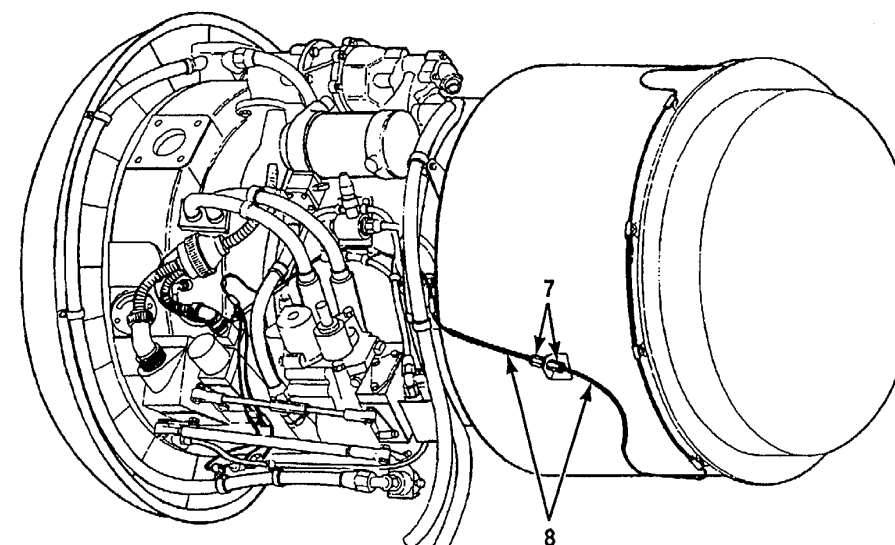

NO. 2 (RIGHT) ENGINE-L SIDE

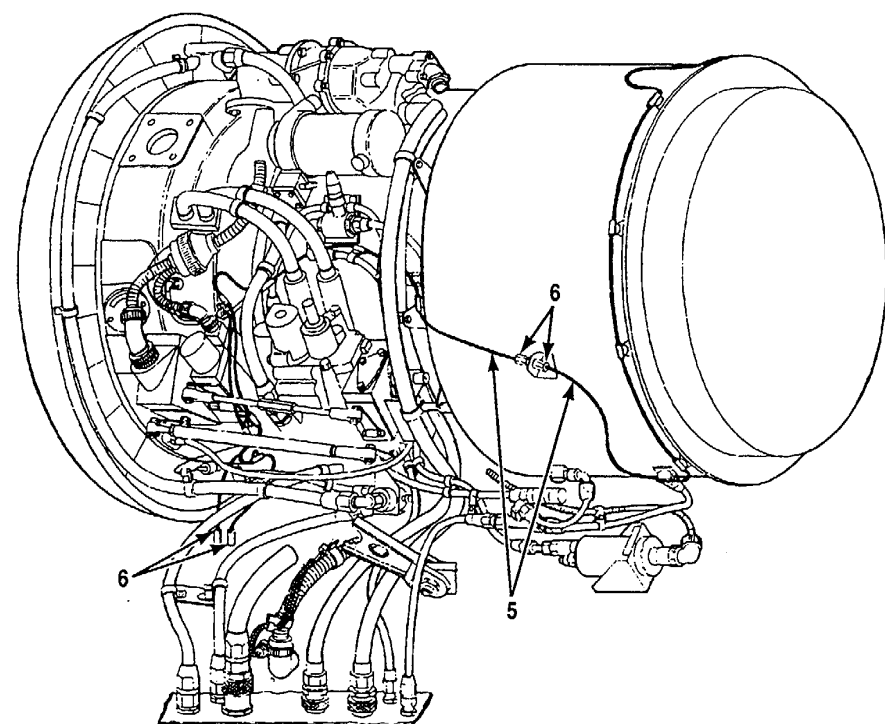
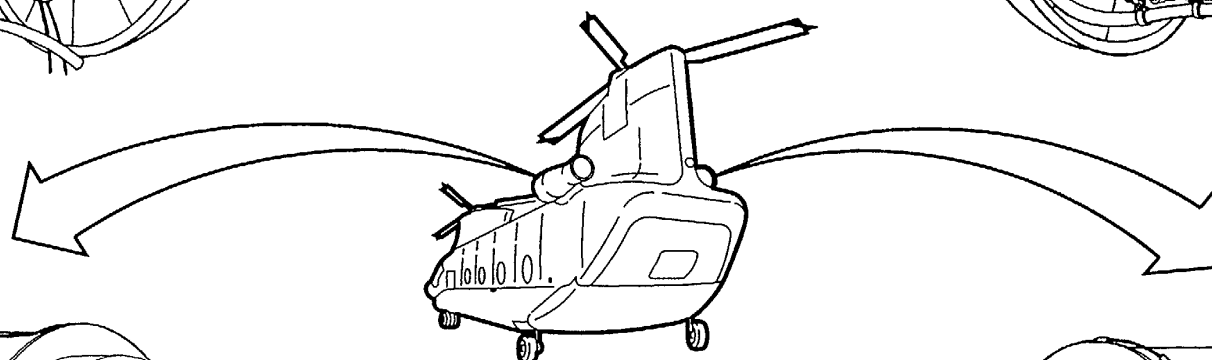

NO. 1 (LEFT) ENGINE-L SIDE

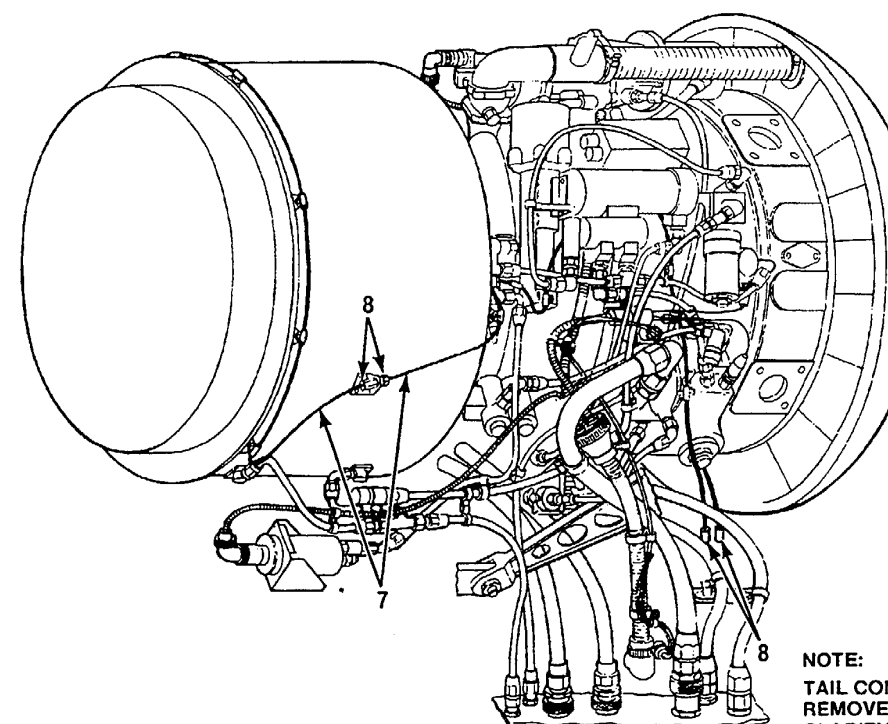

NO. 2 (RIGHT) ENGINE-R SIDE

NOTE:
TAIL CONES
REMOVED FOR
CLARITY

530000-A65466

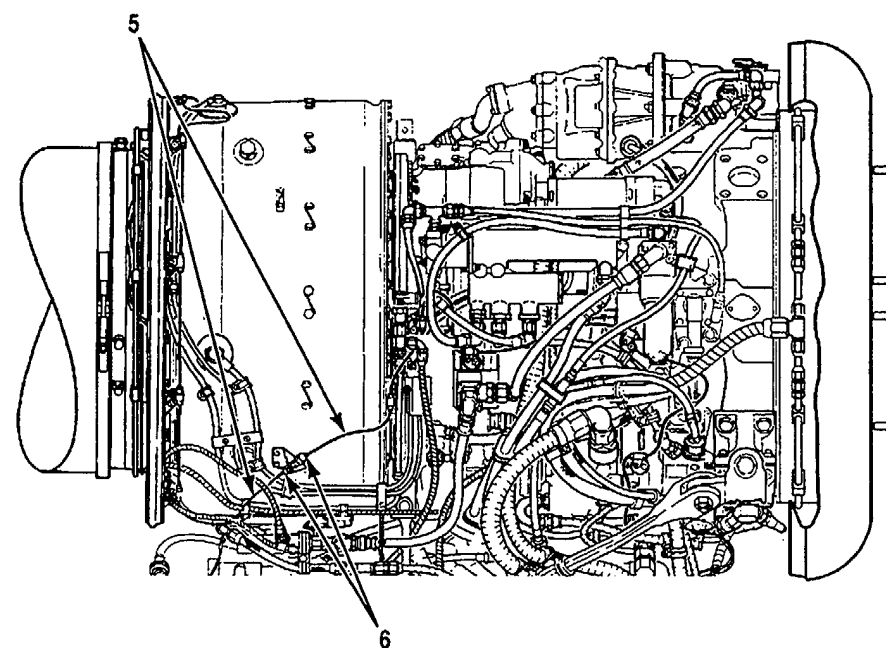

NO. 1 (LEFT) ENGINE - R SIDE

WITH 74

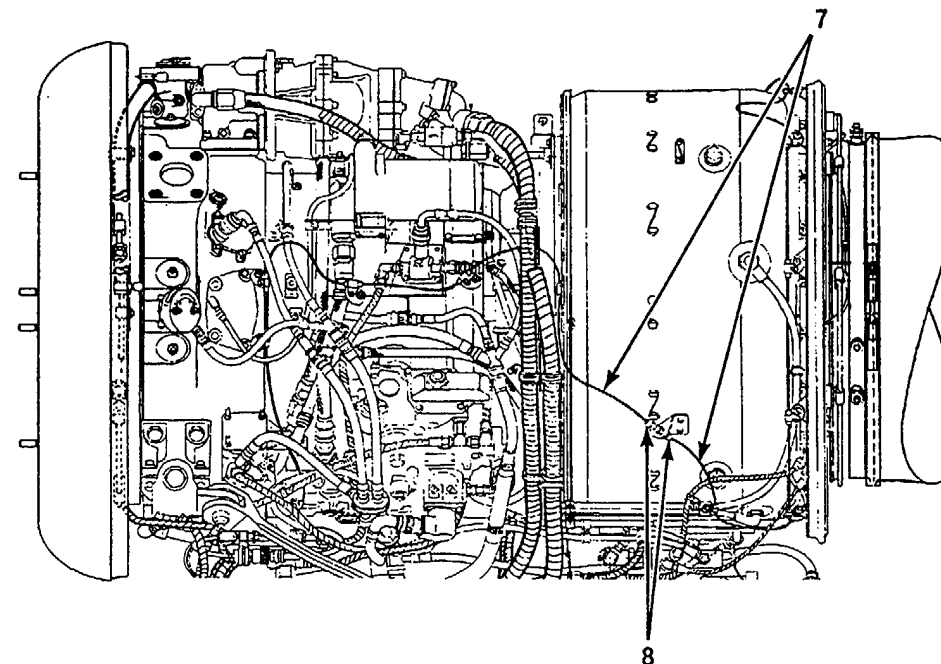

NO. 2 (RIGHT) ENGINE - L SIDE

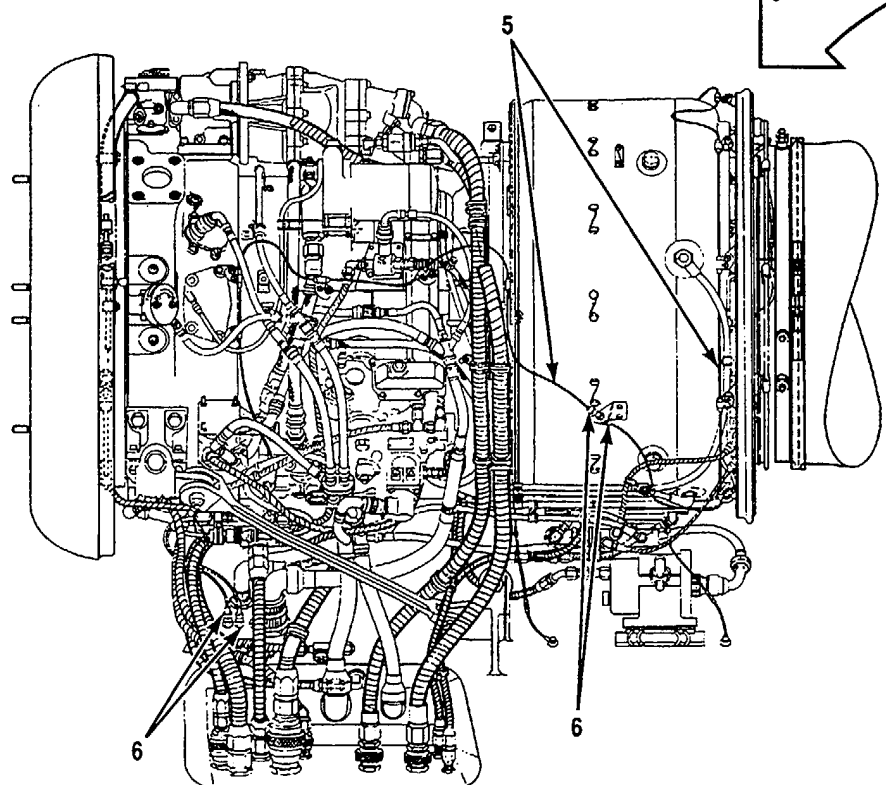
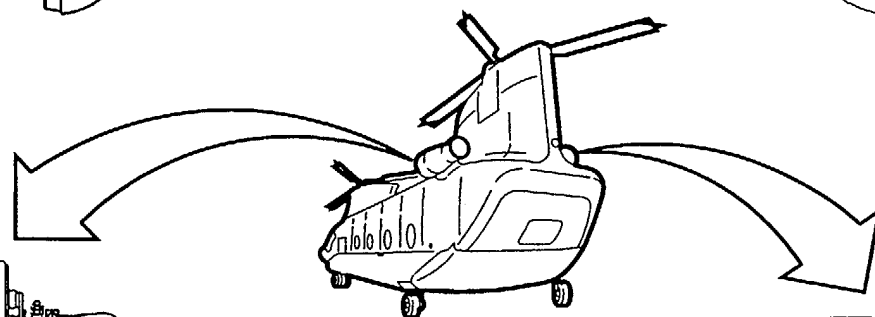

NO. 1 (LEFT) ENGINE - L SIDE

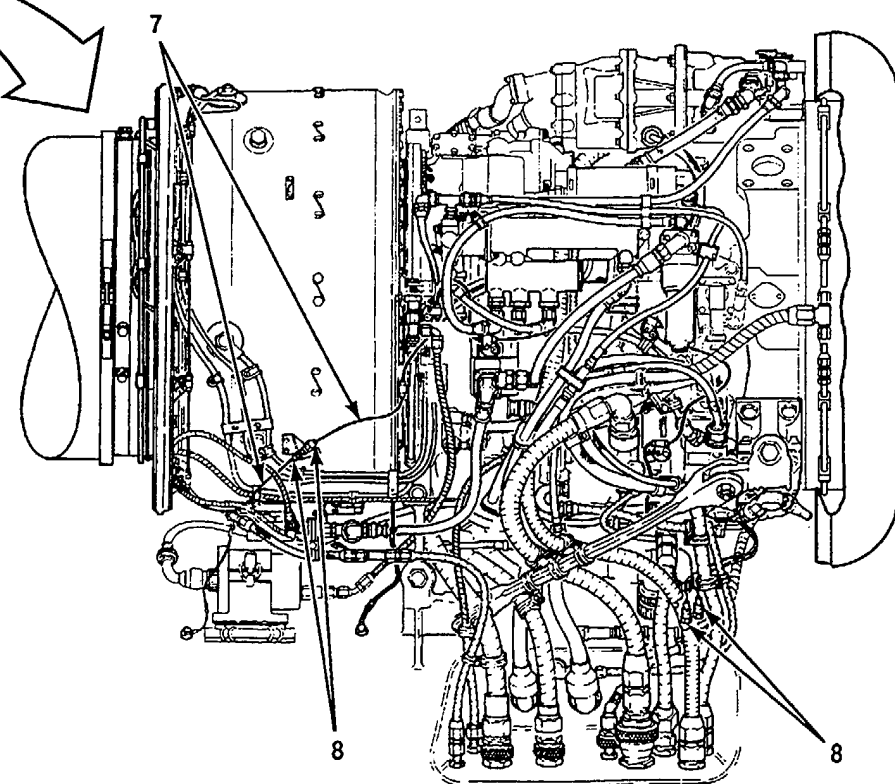

NO. 2 (RIGHT) ENGINE - R SIDE

NOTE:
TAIL CONES
REMOVED FOR
CLARITY

A65465

12-2.4 FIRE DETECTION SYSTEM OPERATIONAL CHECK

INITIAL SETUP

Applicable Configurations:

All

Tools:

None

Materials:

None

Personnel Required:

Aircraft Electrician

References:

TM 55-1520-240-23

Equipment Condition:

TM 55-1520-240-23:

Battery Connected

Electrical Power On

Hydraulic Power Off

Visual Check of Fire Detection System Performed

(Task 12-2.3)

TASK	RESULT
1. Check that ENGINE NO. 1 FIRE DET circuit breaker (1) is closed.	If ENGINE NO. 1 FIRE DET circuit breaker (1) is open, close it. If it opens again, go to task 12-2.5.
2. Check that ENGINE NO. 2 FIRE DET circuit breaker (2) is closed.	If ENGINE NO. 2 FIRE DET circuit breaker (2) is open, close it. If it opens again, go to task 12-2.5.
3. Check NO. 1 ENGINE and NO. 2 ENGINE fire handles (3 and 4).	If either fire handle (3 or 4) caption FIRE PULL/FUEL SHUTOFF is lit, go to task 12-2.6 or 12-2.7.
4. Set and hold FIRE DETECTOR switch (5) to TEST.	FIRE PULL/FUEL SHUTOFF captions in NO. 1 ENGINE and NO. 2 ENGINE fire handle (3 and 4) shall light. If both captions do not come on, go to task 12-2.8. If either caption does not come on, go to task 12-2.9 or 12-2.10.
5. Release FIRE DETECTOR switch (5).	Both FIRE PULL/FUEL SHUTOFF captions in NO. 1 ENGINE and NO. 2 ENGINE fire handles (3 and 4) shall go out. If both captions do not go out, replace FIRE DETECTOR switch (5).

FOLLOW-ON MAINTENANCE:

TM 55-1520-240-23:

Electrical power off.

Battery disconnected.

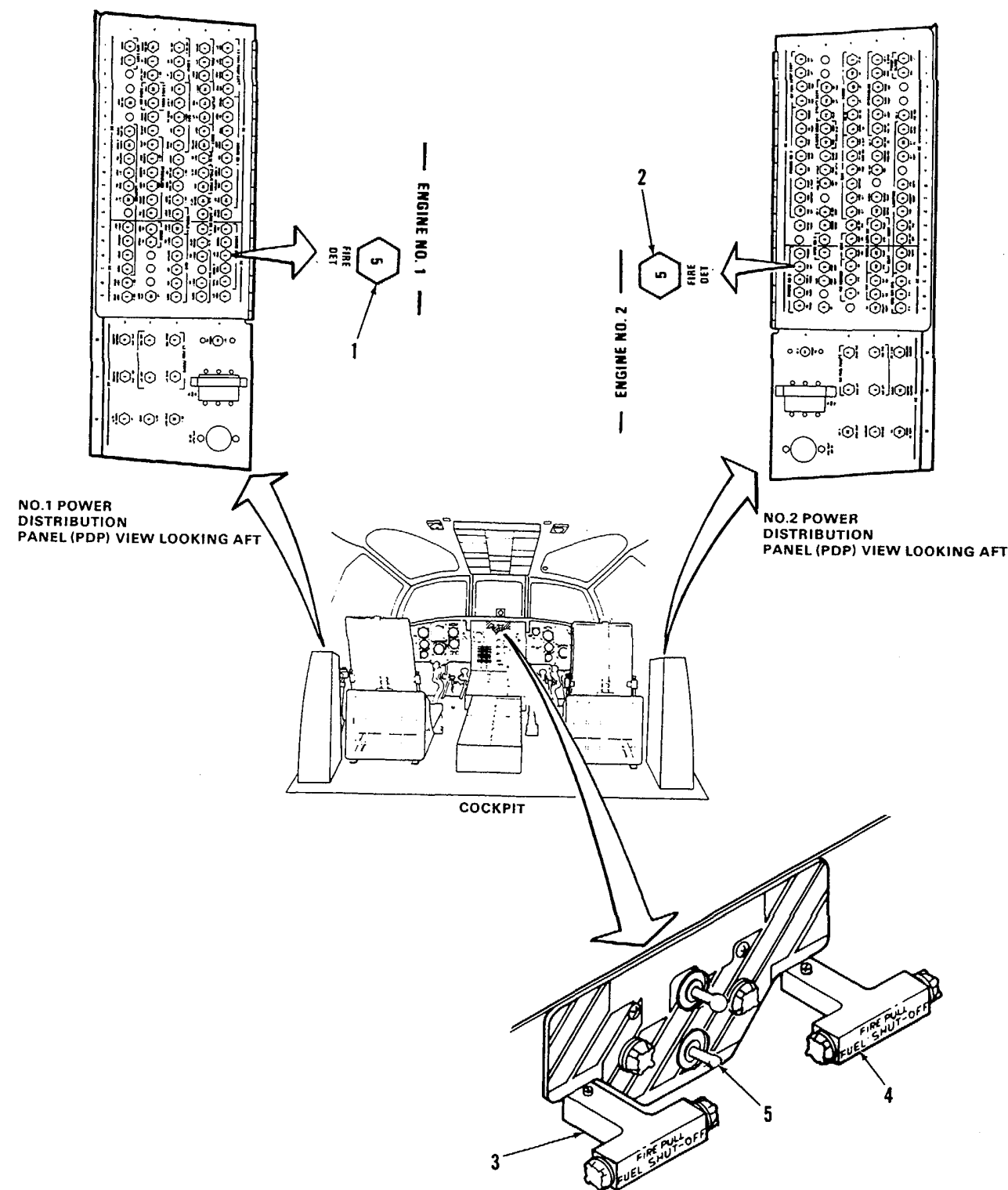

45x54

D145-5030-SPA

END OF TASK
Change 23 12-34.1/(12-34.2 blank)

12-2.5 FIRE DET CIRCUIT BREAKER WILL NOT STAY CLOSED

FAULT ISOLATION PROCEDURE

INITIAL SETUP

Applicable Configurations:
All

Tools:
Electrical Repairer's Tool Kit,
NSN 5180-00-323-4915
Multimeter

Materials:
None

Personnel Required:
68F20 Aircraft Electrician

References:
TM 55-1520-240-23

Equipment Condition:
TM 55-1520-240-23:
Battery Disconnected
Electrical Power Off
Hydraulic Power Off

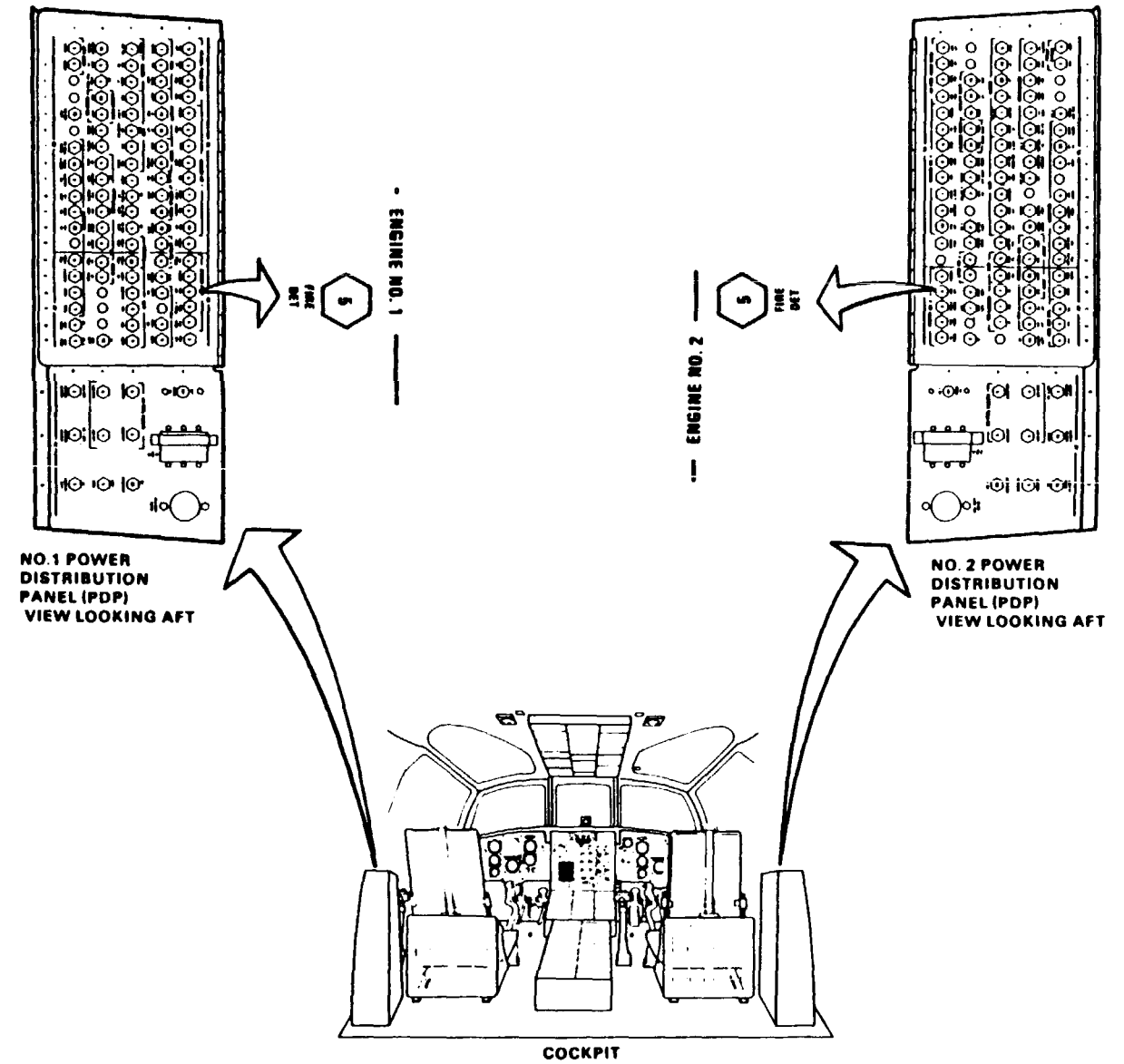
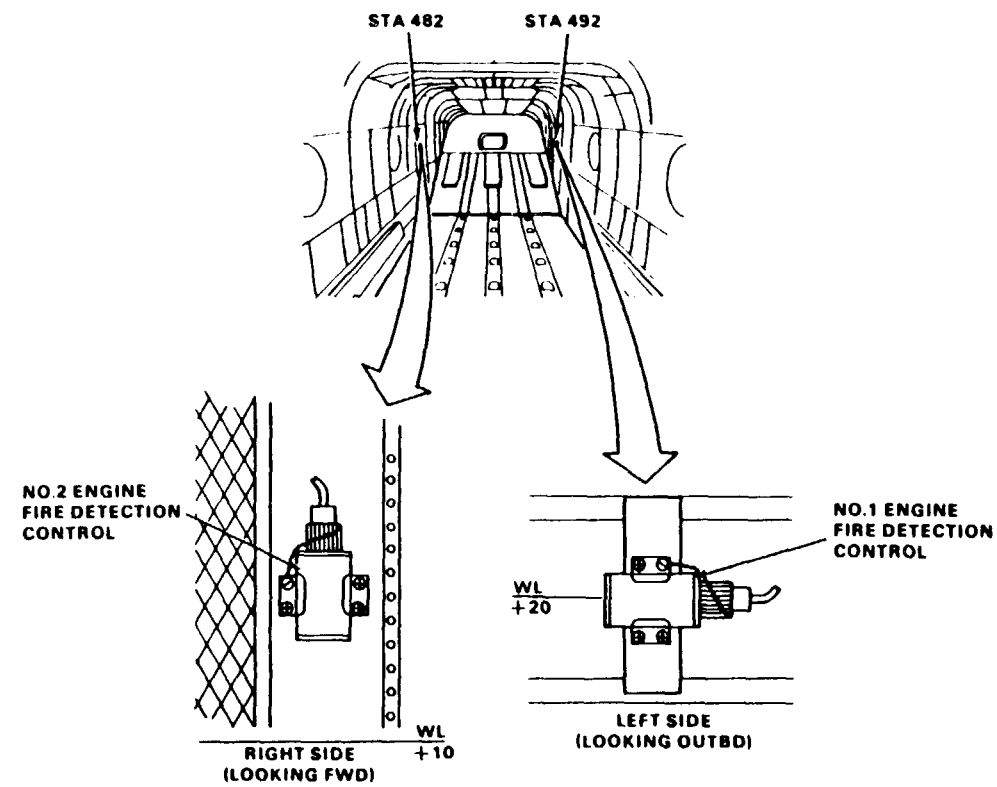

**ENGINE NO. 1 FIRE DET CIRCUIT BREAKER
WILL NOT STAY CLOSED**

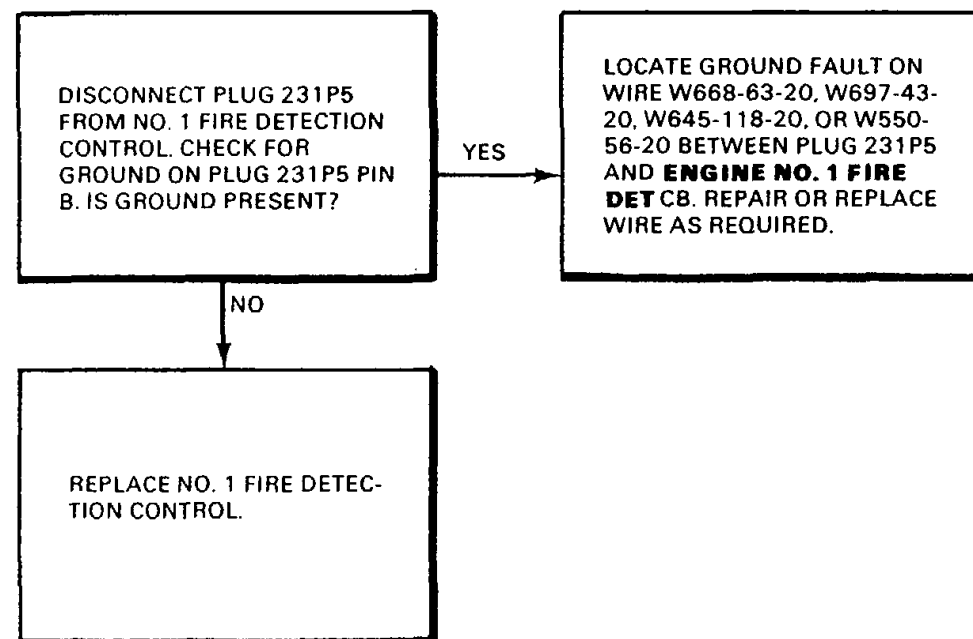

**ENGINE NO. 2 FIRE DET CIRCUIT BREAKER
WILL NOT STAY CLOSED**

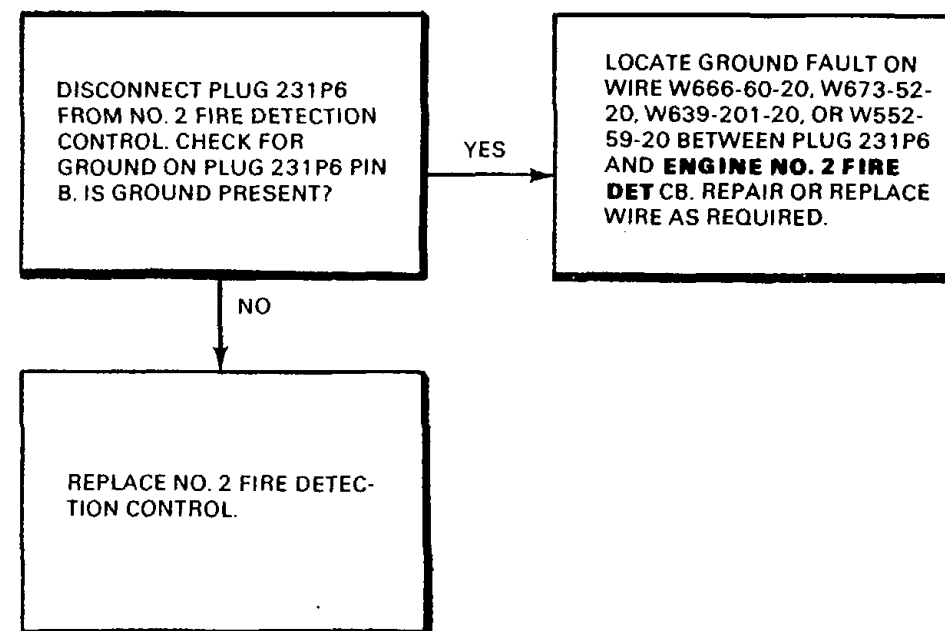

FAULT ISOLATION PROCEDURE

INITIAL SETUP

Applicable Configurations:

All **References:**

Tools:

Electrical Repairer's Tool Kit,
NSN 5180-00-323-4915

Multimeter

Materials:

Cloth (E120)

Personnel Required:

Aircraft Electrician

TM 55-1520-240-23

Equipment Condition:

TM 55-1520-240-23:

Battery Connected

Electrical Power On

Hydraulic Power Off

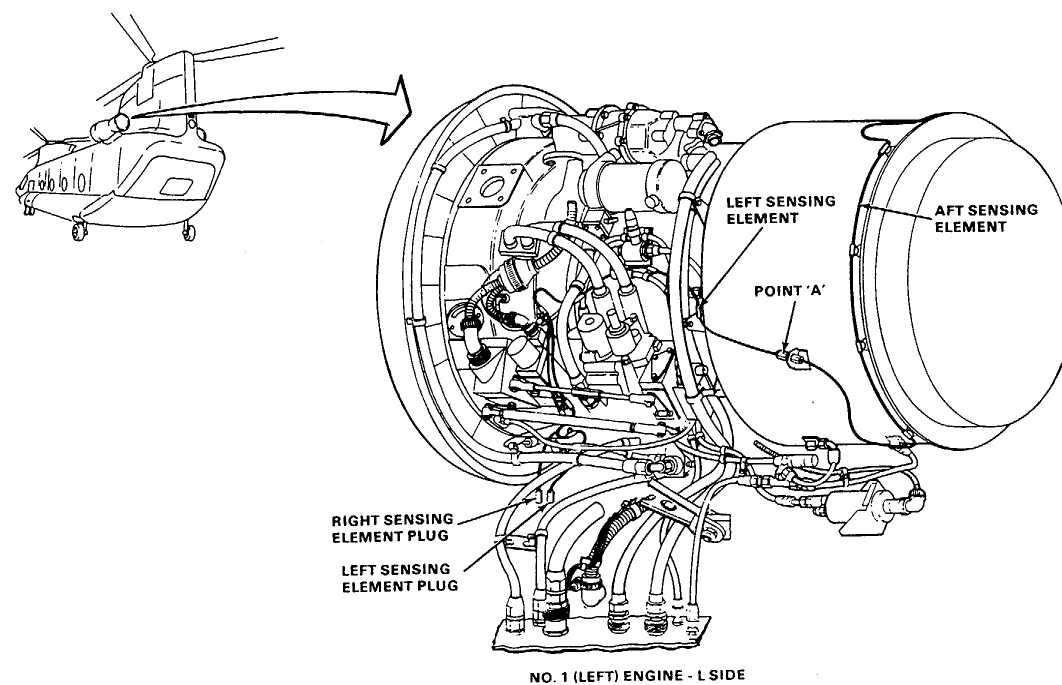
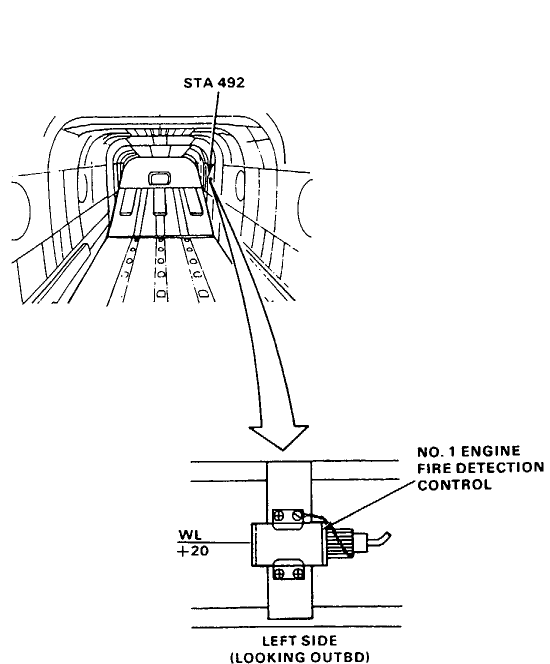
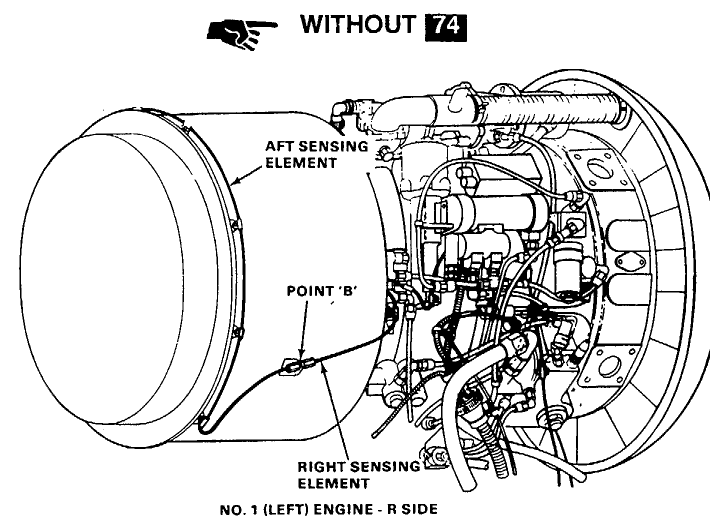

NOTE:
TAIL CONE
REMOVED FOR
CLARITY

D145-5032-5PA

90154

WITH 74

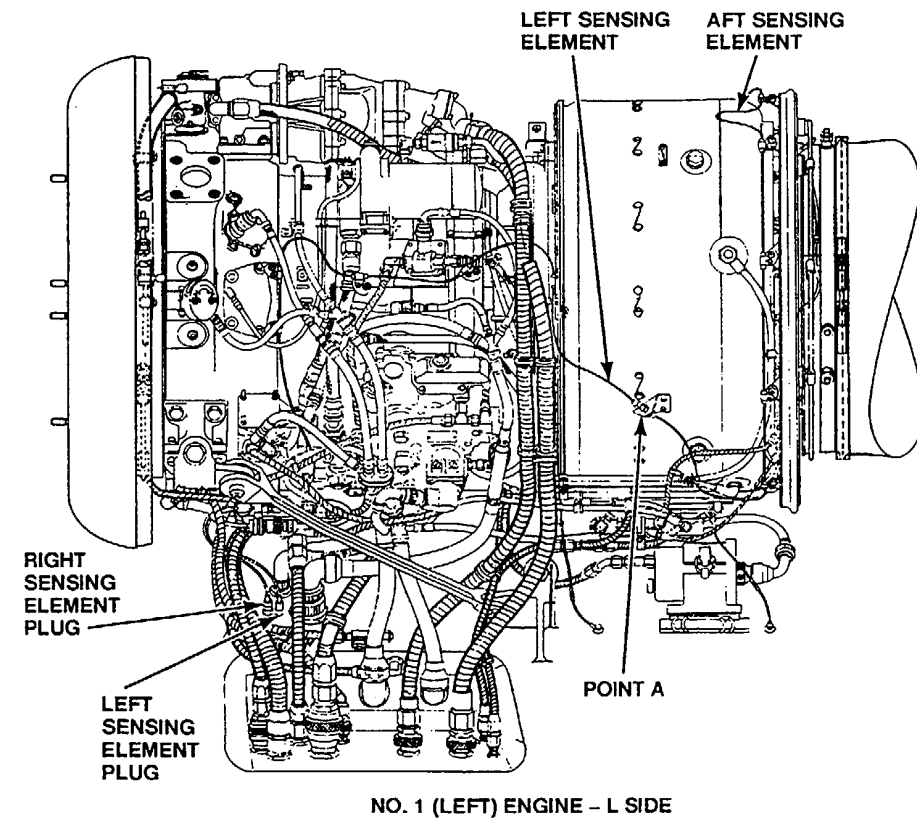
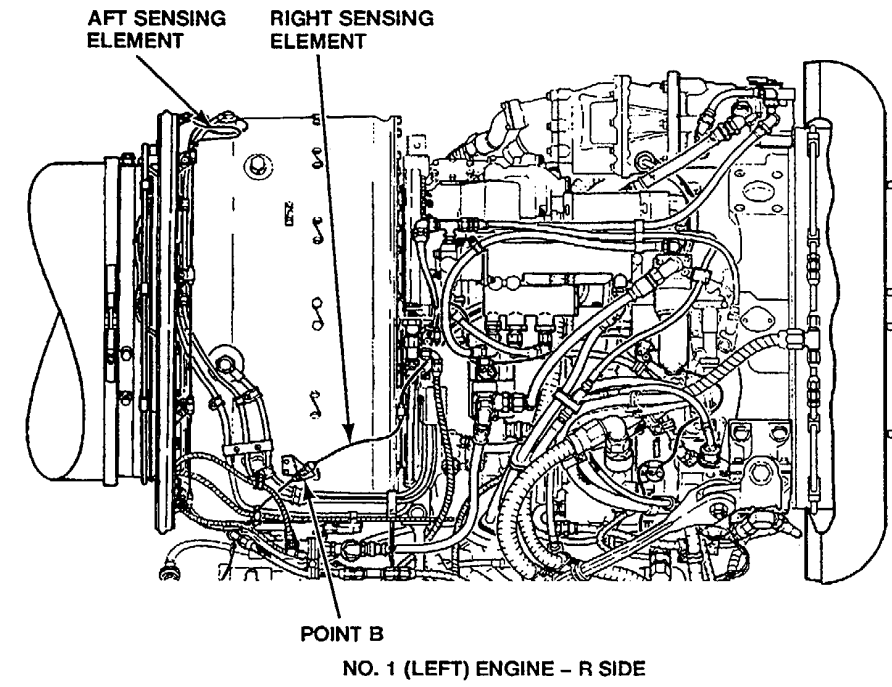
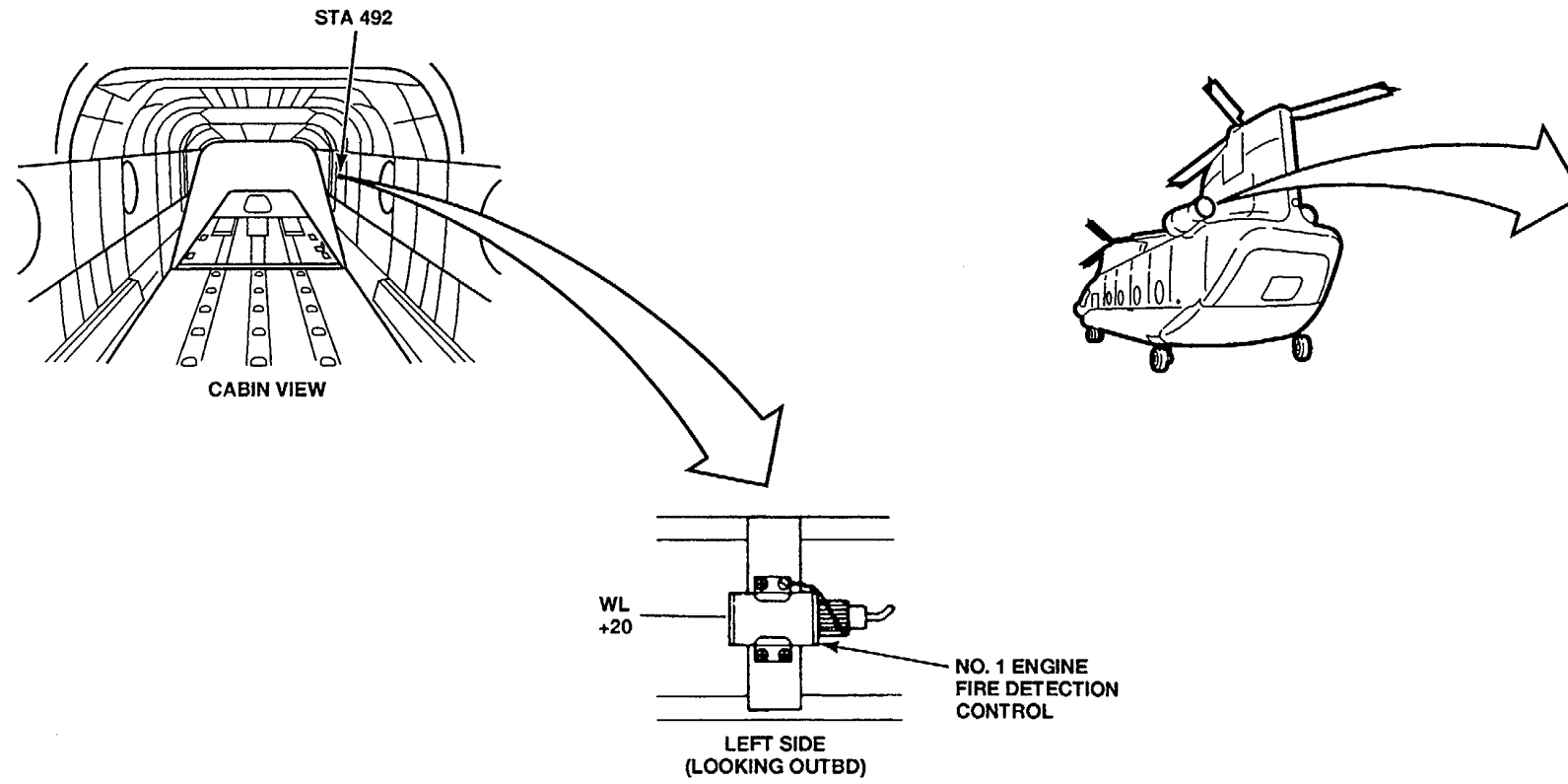

A65467

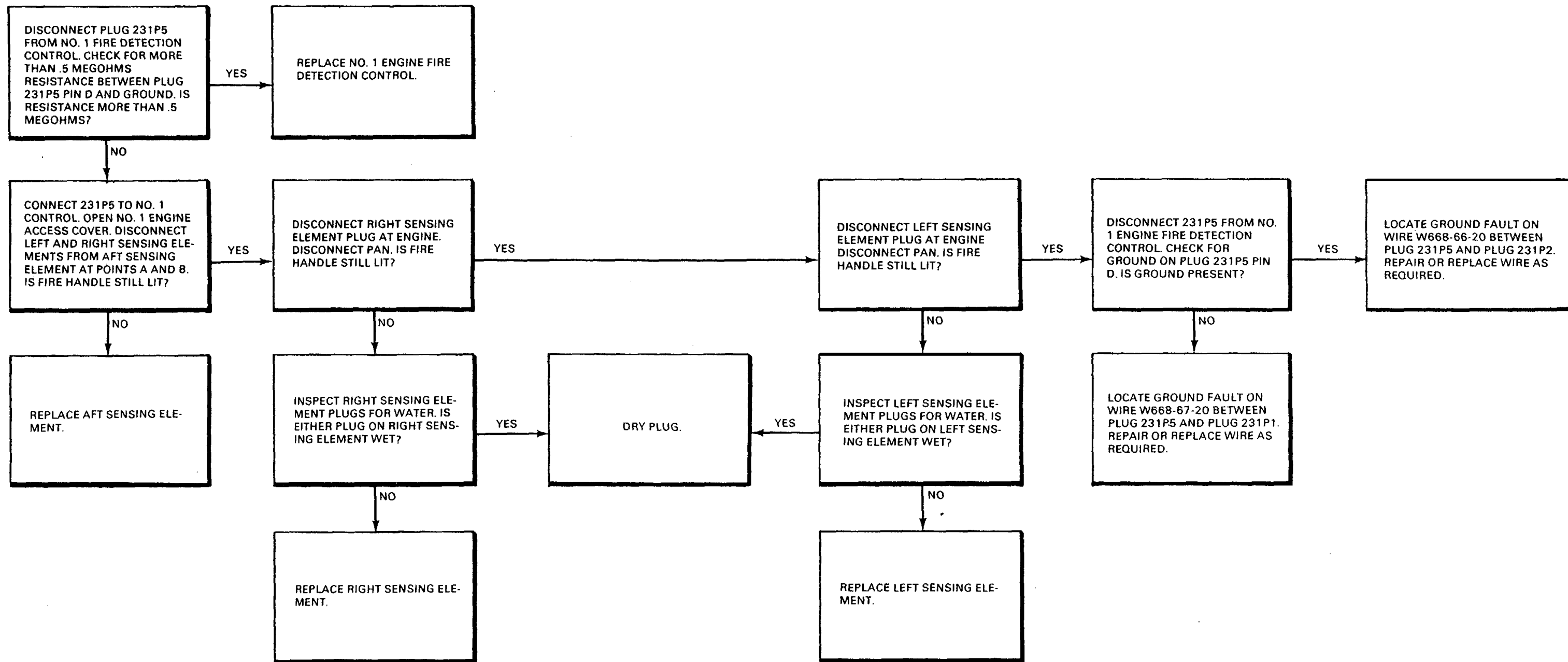

FAULT ISOLATION PROCEDURE

INITIAL SETUP

Applicable Configurations:

All **References:**

Tools:

Electrical Repairer's Tool Kit,
NSN 5180-00-323-4915

Multimeter

Materials:

Cloth (E120)

Personnel Required:

Aircraft Electrician

TM 55-1520-240-23

Equipment Condition:

TM 55-1520-240-23:

Battery Connected

Electrical Power On

Hydraulic Power Off

WITHOUT 74

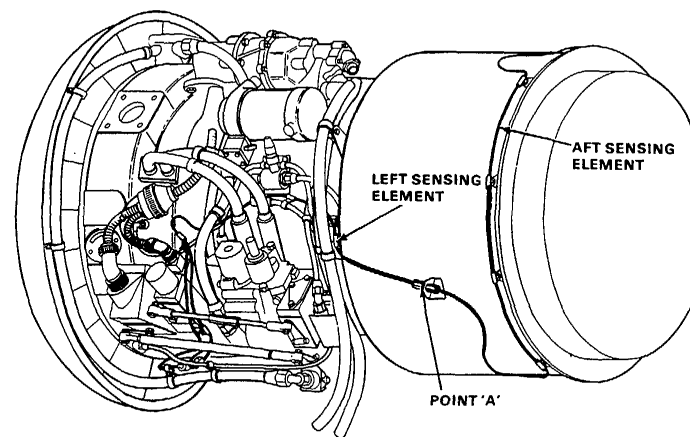

NO. 2 (RIGHT) ENGINE - L SIDE

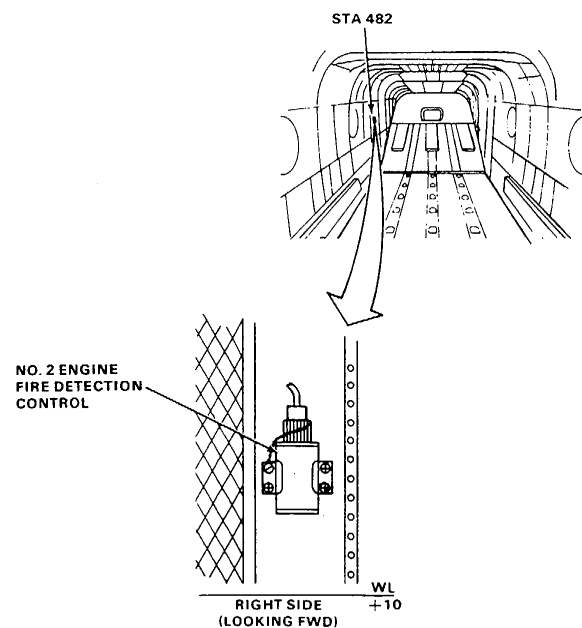

90x54

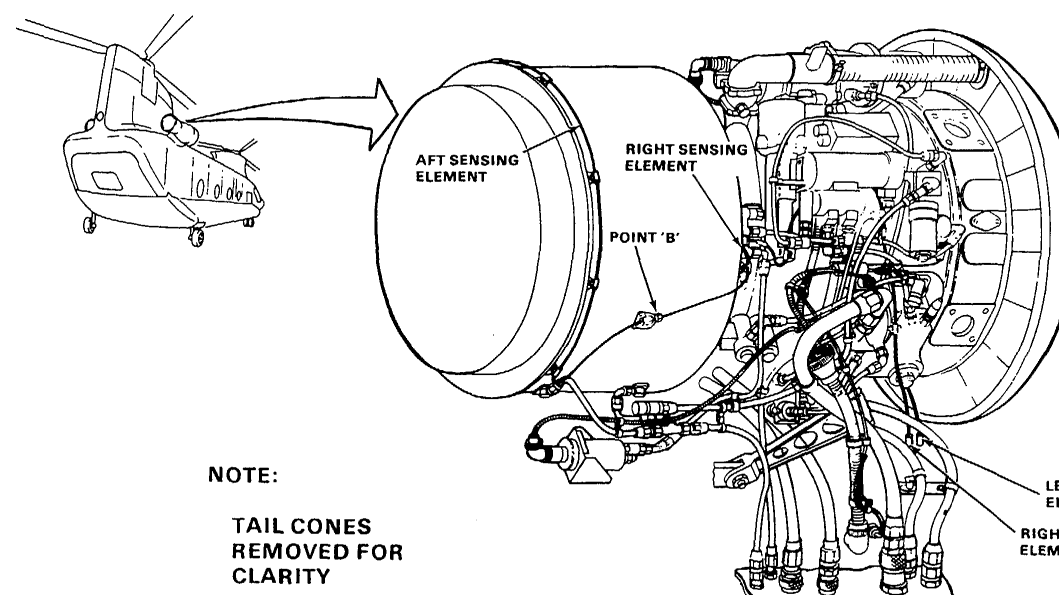

NOTE:

**TAIL CONES
REMOVED FOR
CLARITY**

NO. 2 (RIGHT) ENGINE - R SIDE

D145-5033-5PA

WITH 74

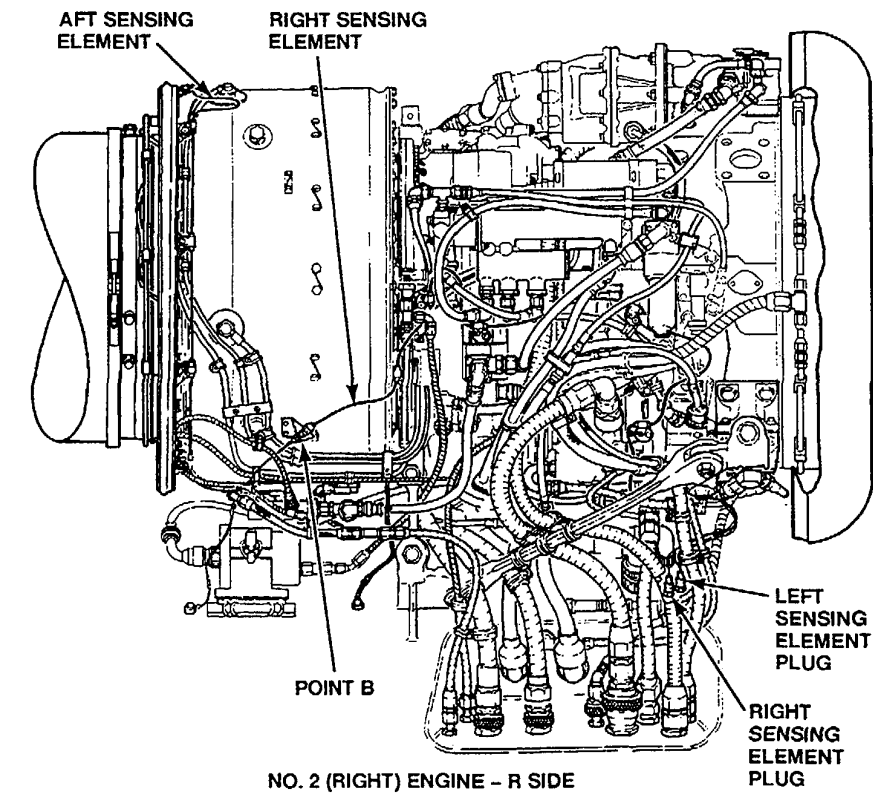
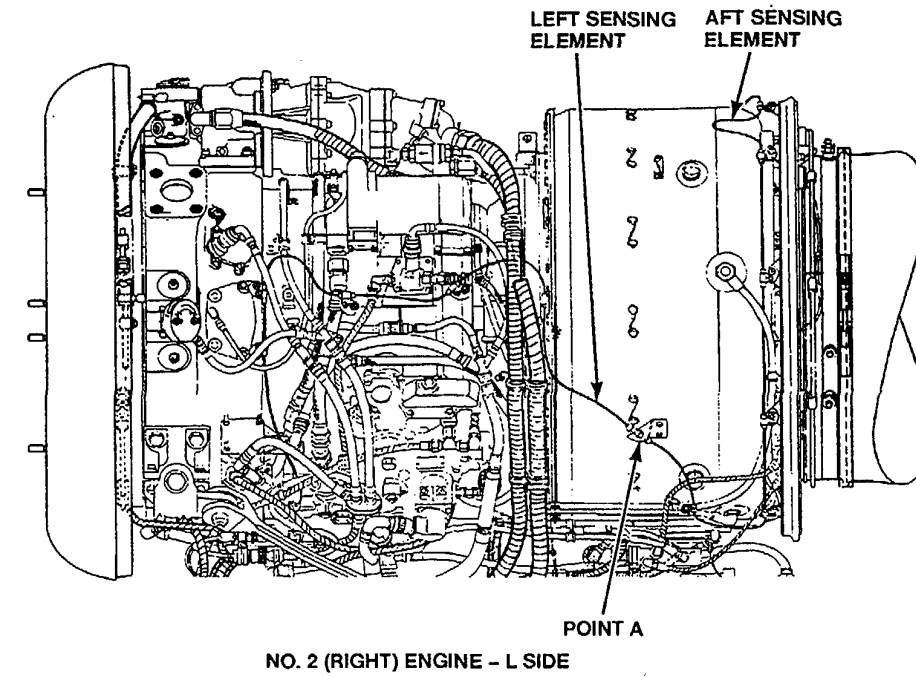
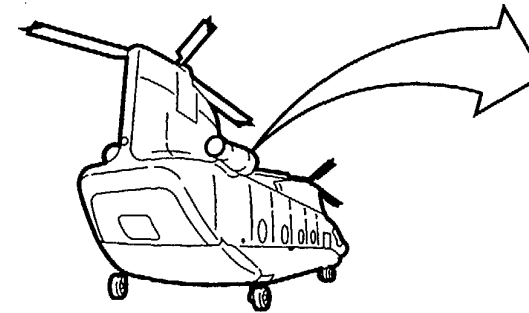
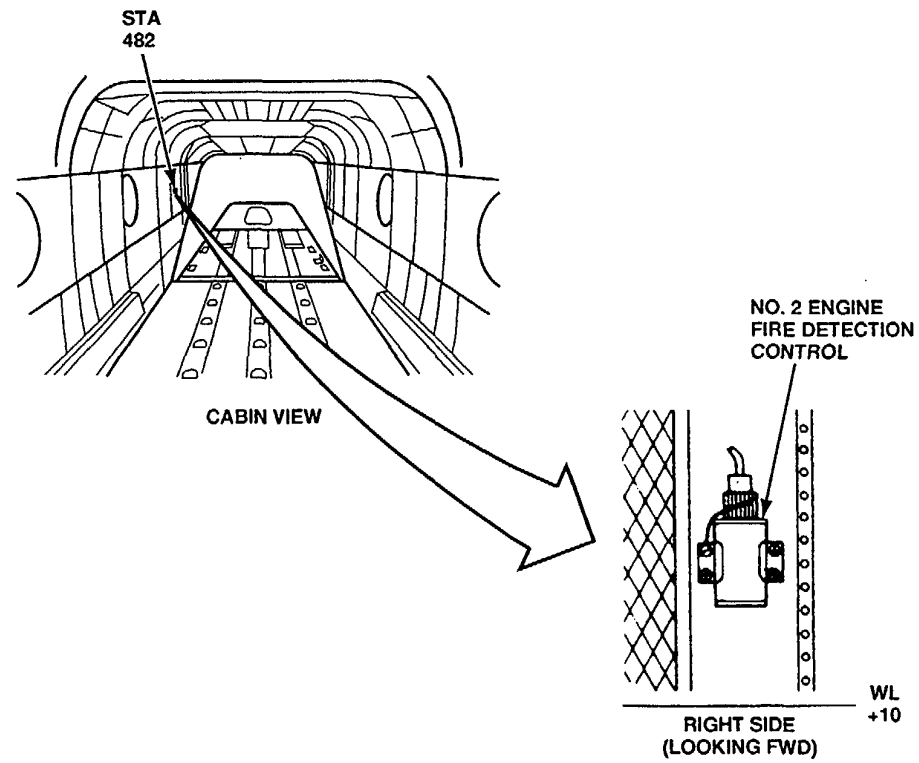

NOTE:
TAIL CONES
REMOVED FOR
CLARITY

A65468

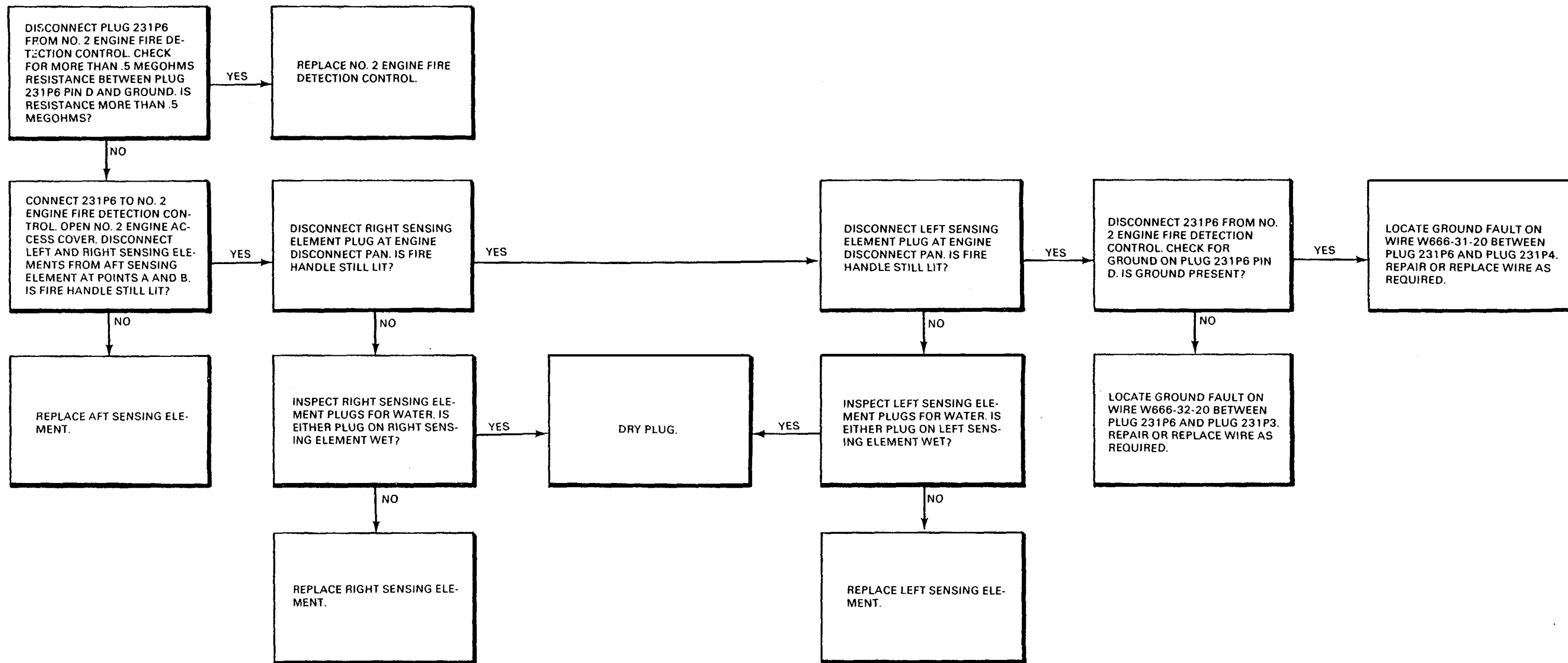

FAULT ISOLATION PROCEDURE

INITIAL SETUP

Applicable Configurations
All

Tools:
Electrical Repairer's Tool Kit,
NSN 5180-00-323-4915
Multimeter

Materials:
None

Personnel Required:

Aircraft Electrician

References:

TM 55-1520-240-23

Equipment Condition:

TM 55-1520-240-23:
Battery Connected
Electrical Power On
Hydraulic Power Off

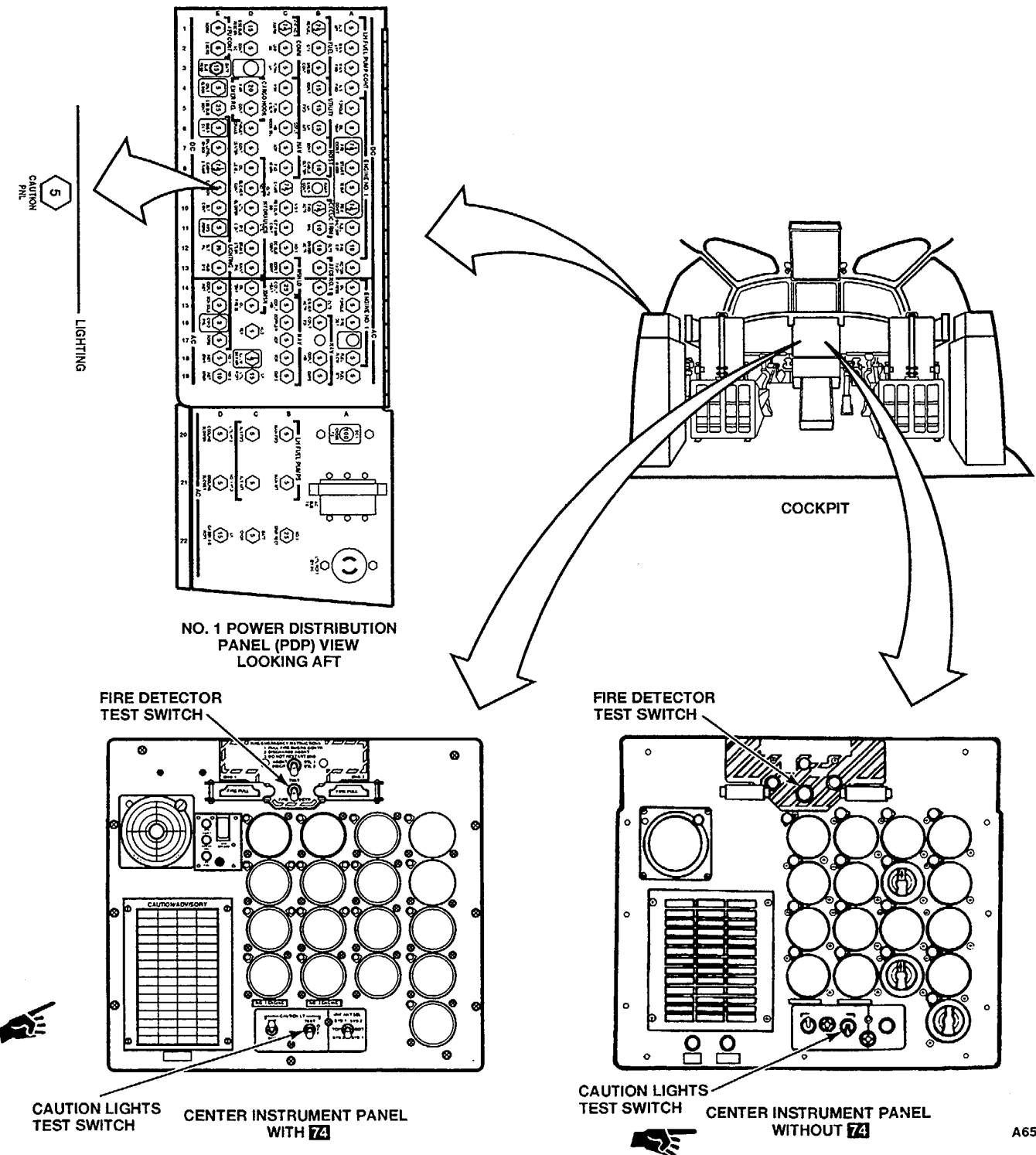
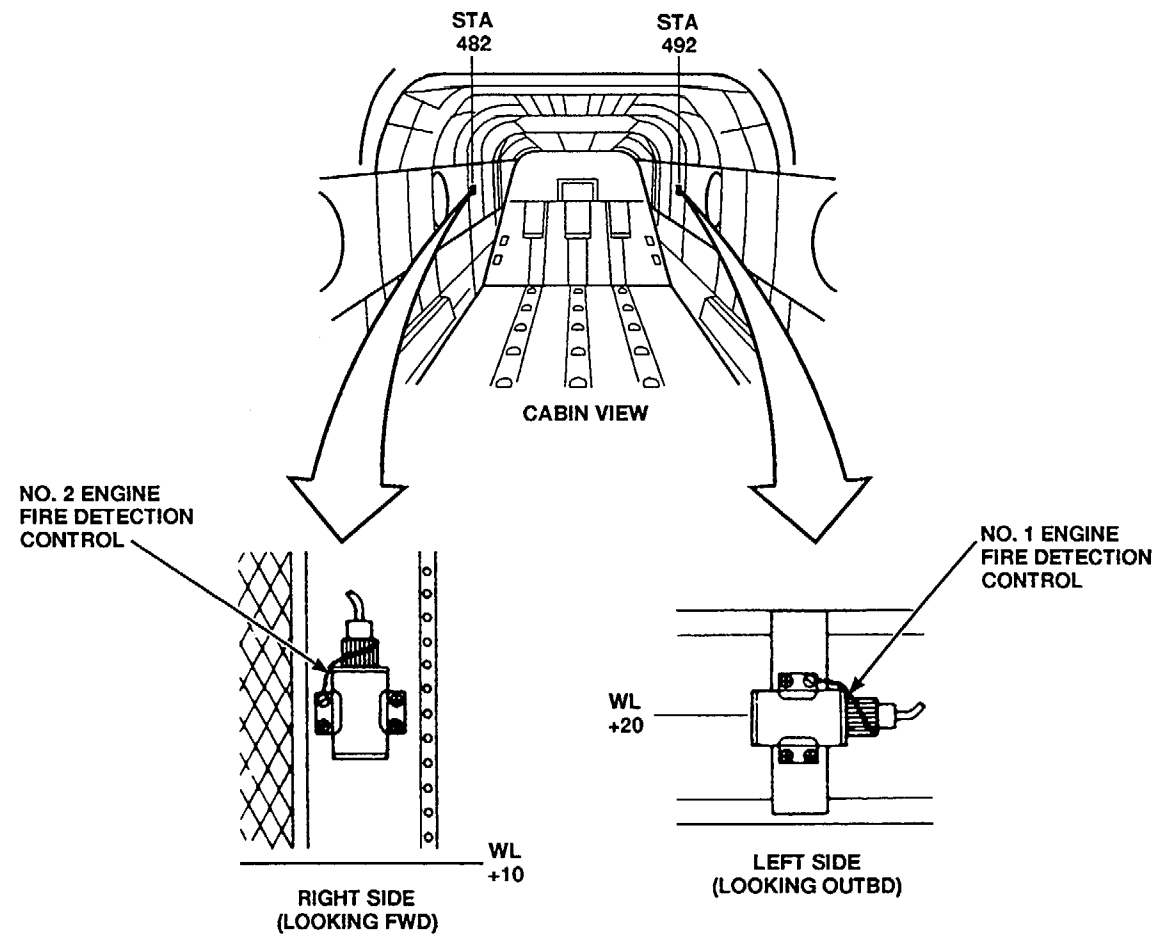

12-2.8 NO. 1 AND NO. 2 ENGINE FIRE HANDLE FIRE PULL/FUEL SHUTOFF-CAPTIONS DO NOT LIGHT DURING TEST (Continued)

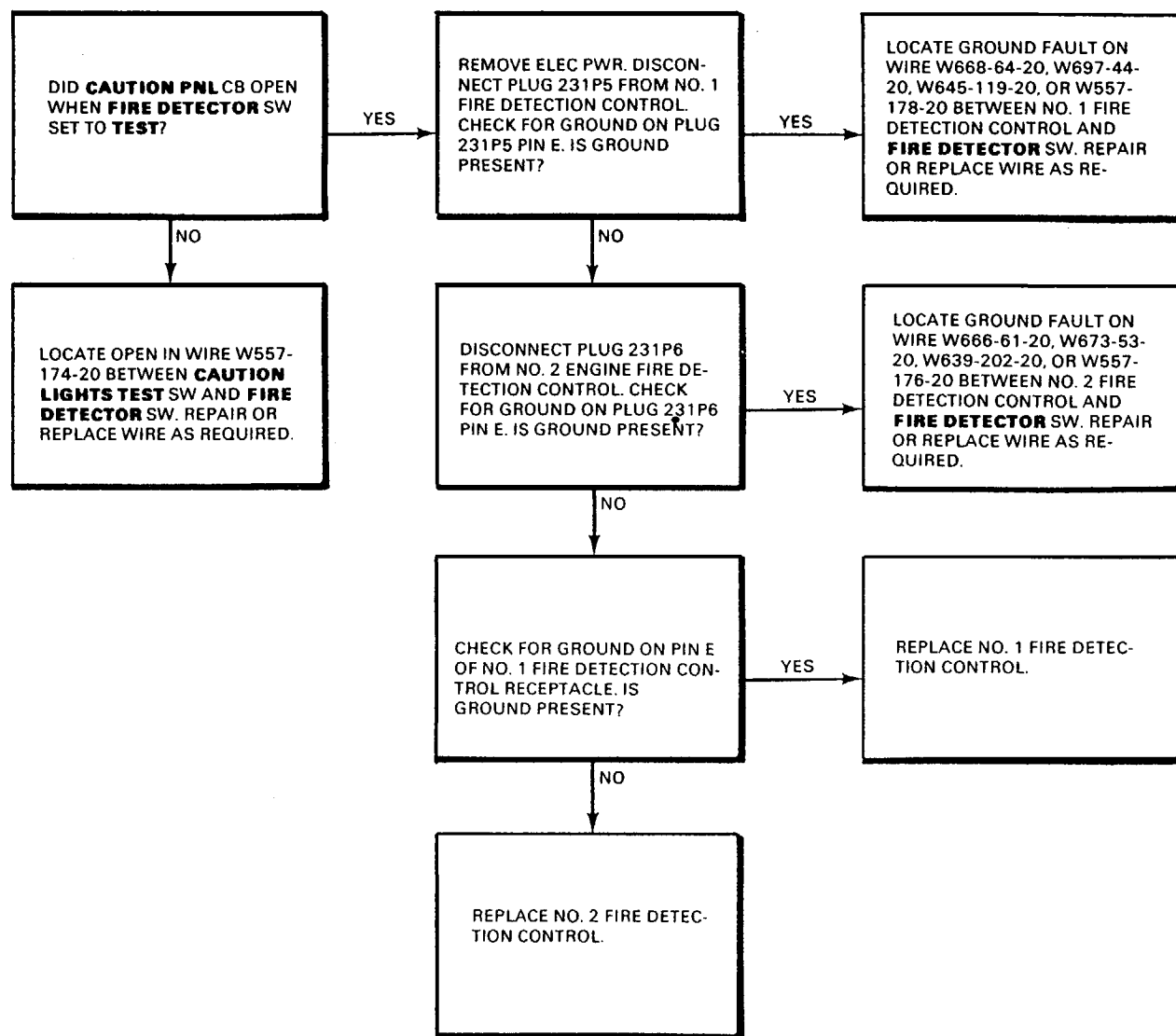

END OF TASK

12-2.9 NO. 1 ENGINE FIRE HANDLE FIRE PULL/FUEL SHUTOFF CAPTION DOES NOT LIGHT DURING TEST

FAULT ISOLATION PROCEDURE

INITIAL SETUP

Applicable Configurations

All

Tools:

- Electrical Repairer's Tool Kit,
NSN 5180-00-323-4915
- Multimeter

Materials:

None

Personnel Required

Aircraft Electrician

References:

TM 55-1520-240-23

Equipment Condition:

- TM 55-1520-240-23:
- Battery Connected
- Electrical Power On
- Hydraulic Power Off

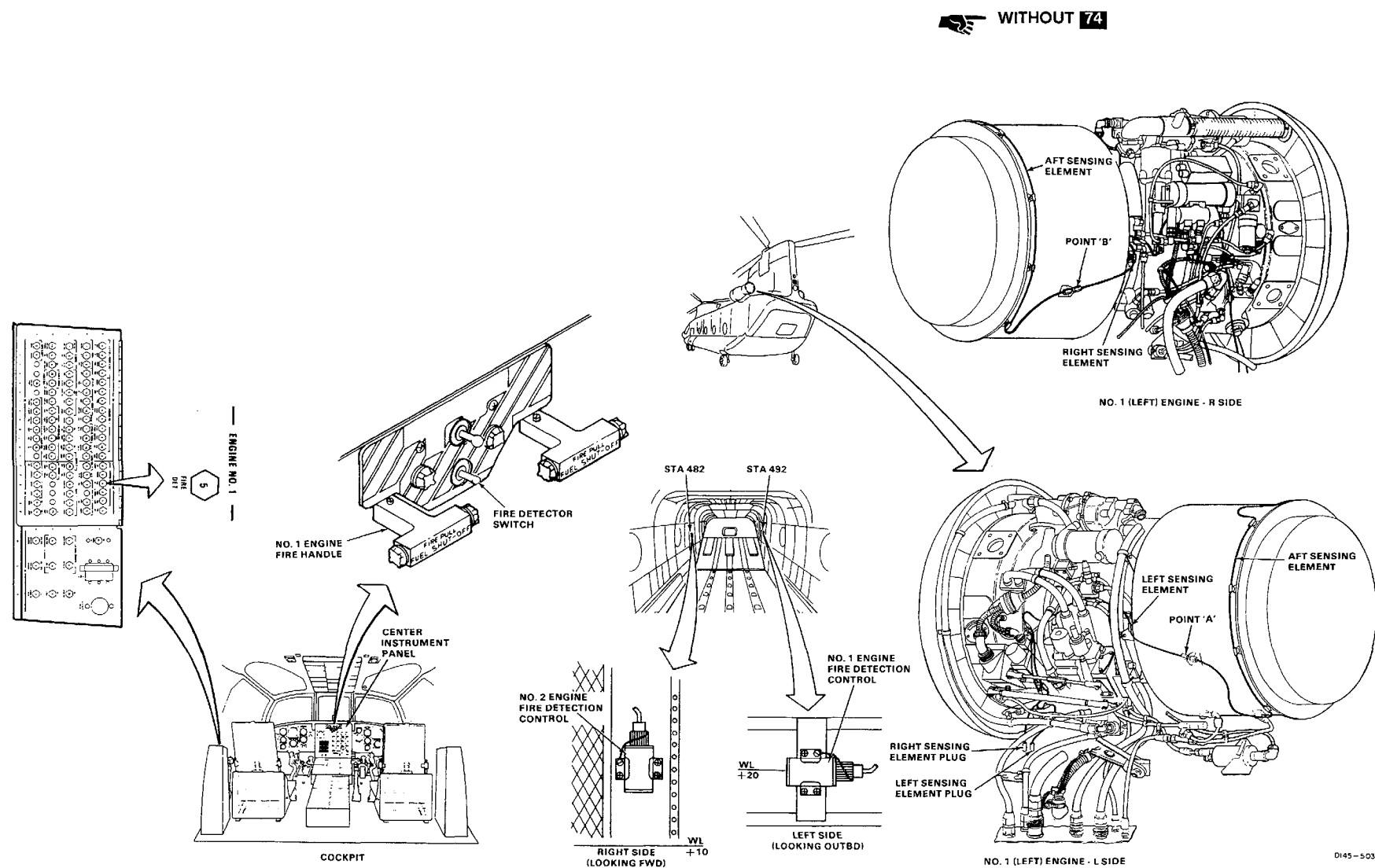

WITH 74

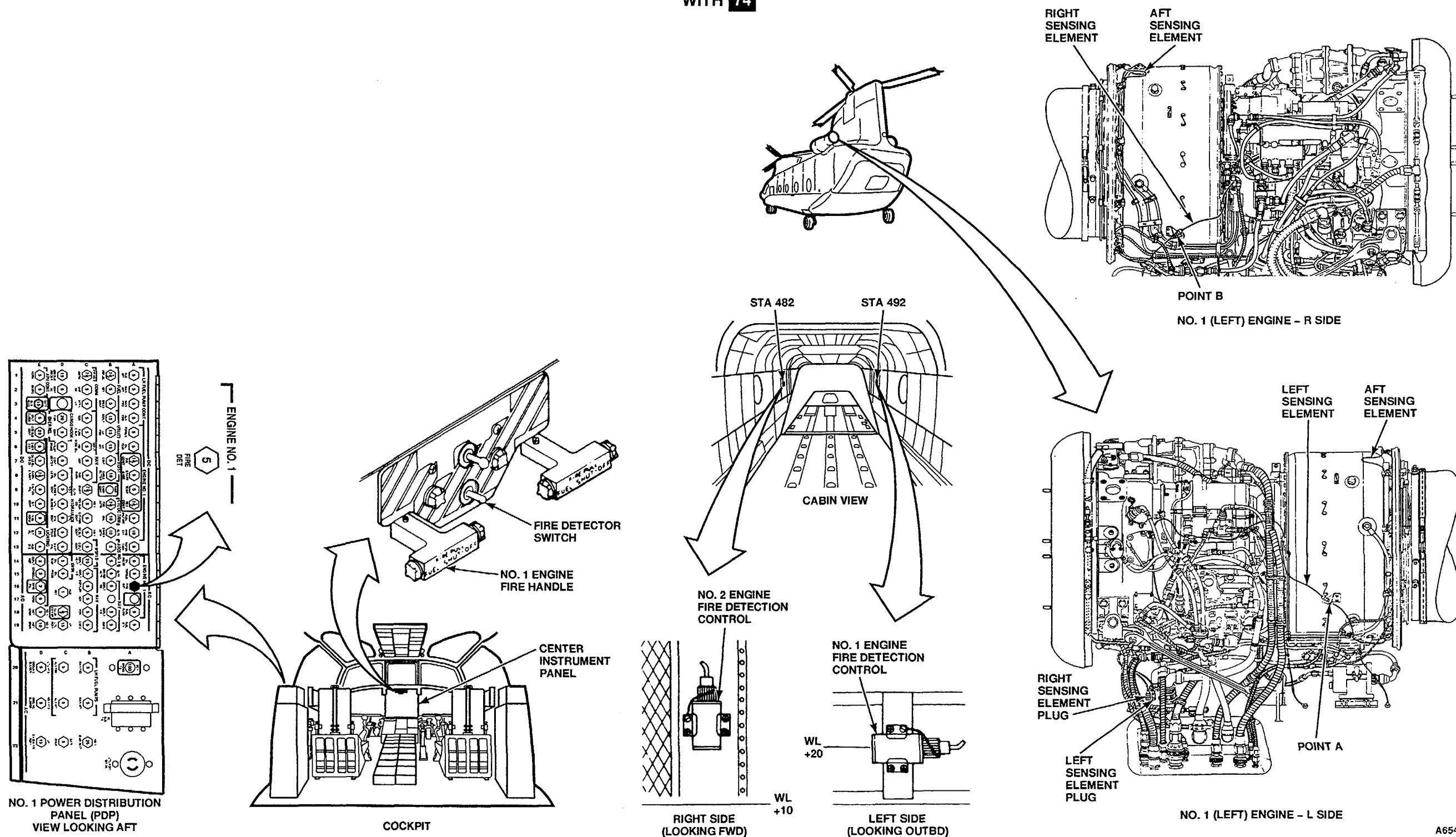

A65470

12-2.9 NO. 1 ENGINE FIRE HANDLE FIRE PULL/FUEL SHUTOFF
CAPTION DOES NOT LIGHT DURING TEST (Continued)

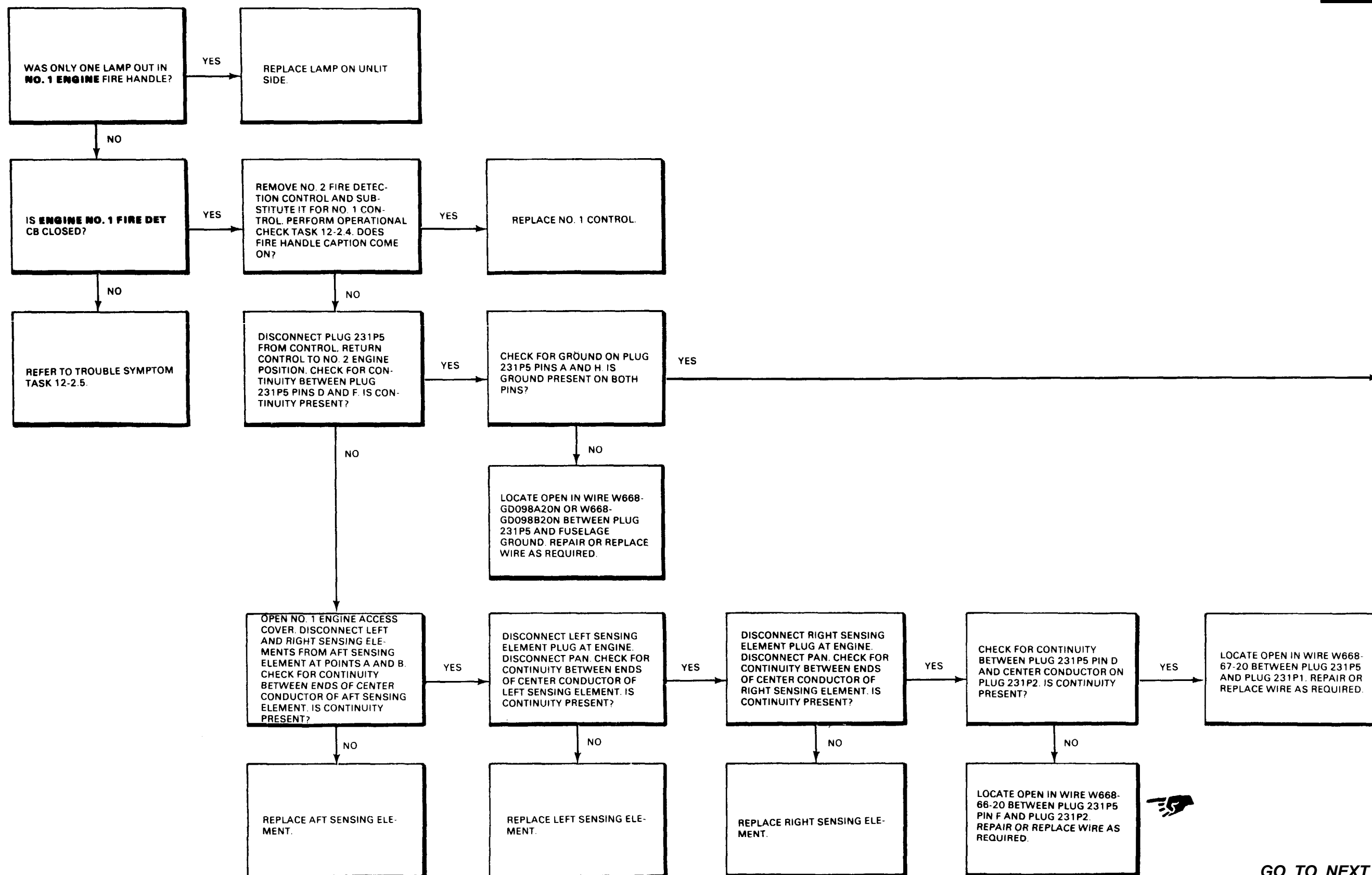

GO TO NEXT PAGE

12-2.9 NO. 1 ENGINE FIRE HANDLE FIRE PULL/FUEL SHUTOFF
 CAPTION DOES NOT LIGHT DURING TEST (Continued)

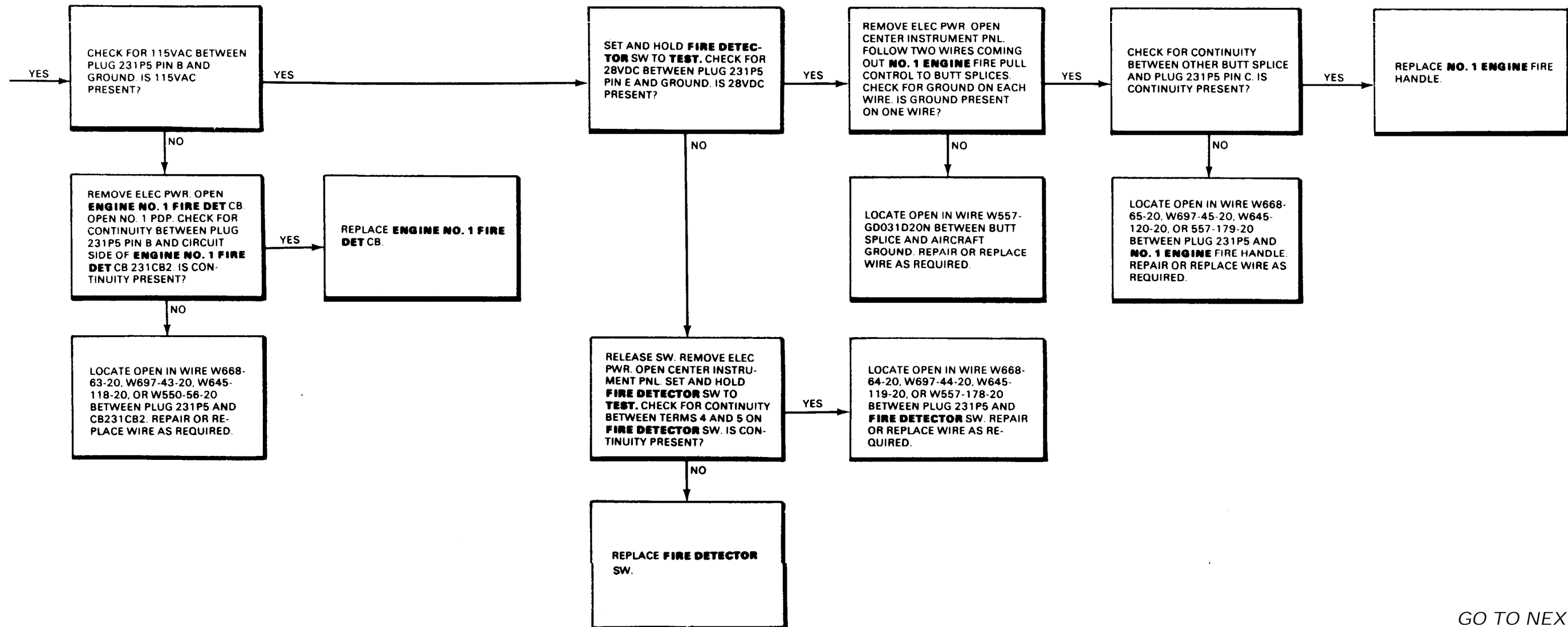

GO TO NEXT PAGE

12-2.9 NO. 1 ENGINE FIRE HANDLE FIRE PULL/FUEL SHUTOFF
CAPTION DOES NOT LIGHT DURING TEST (Continued)

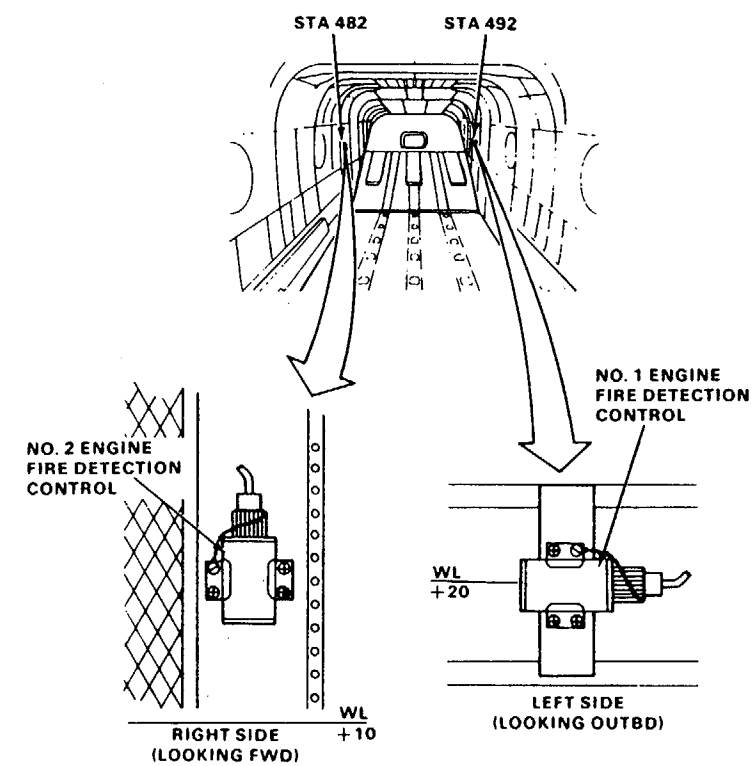
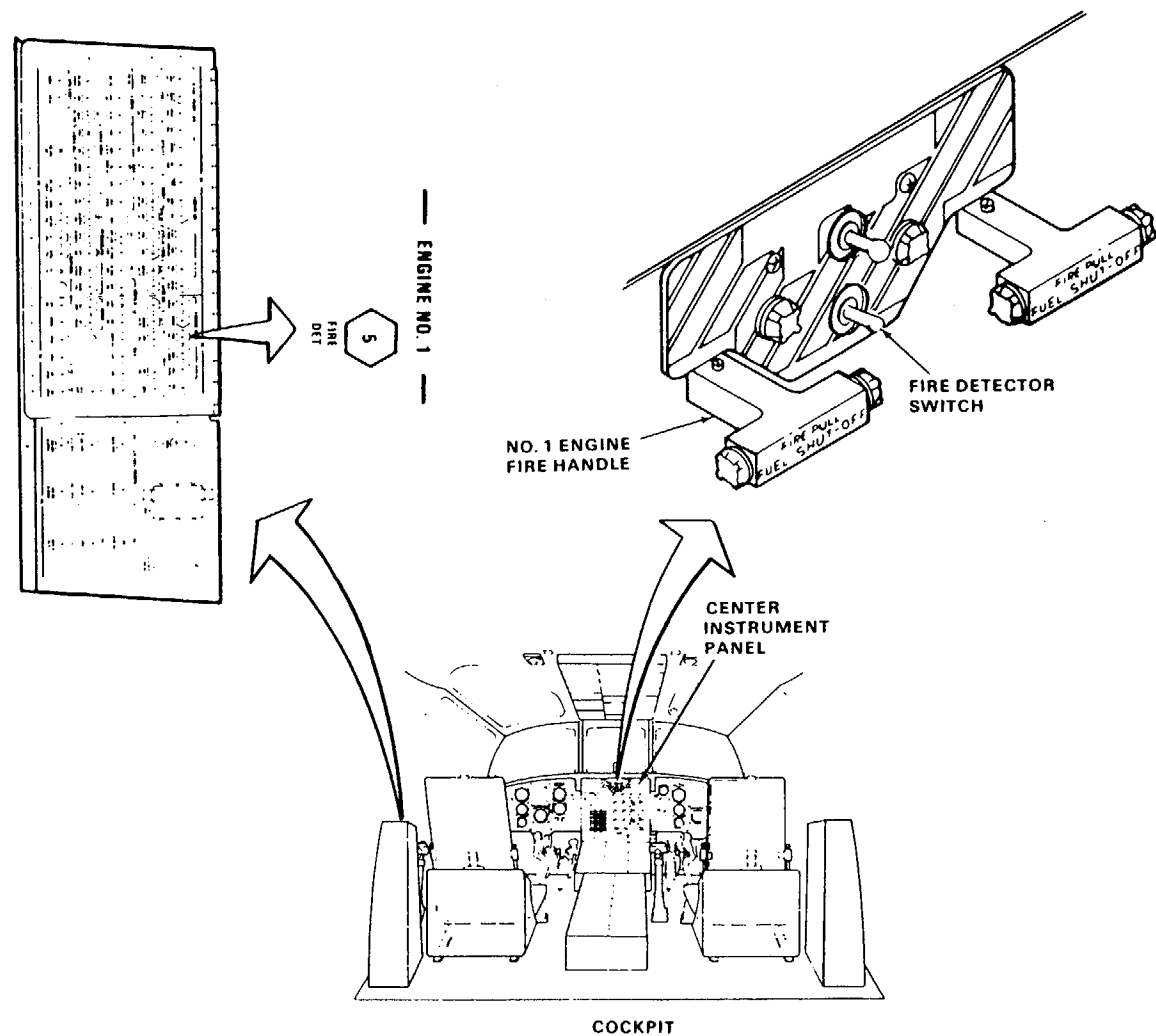

12-2.10 NO. 2 ENGINE FIRE HANDLE FIRE PULL/FUEL SHUTOFF CAPTION DOES NOT LIGHT DURING

FAULT ISOLATION PROCEDURE

INITIAL SETUP

Applicable Configurations

All

Tools:

- Electrical Repairer's Tool Kit, NSN 5180-00-323-4915
- Multimeter

Materials:

None

Personnel Required:
Aircraft Electrician

References:
TM 55-1520-240-23

Equipment Condition:
TM 55-1520-240-23:
Battery Connected
Electrical Power On
Hydraulic Power Off

WITHOUT 74

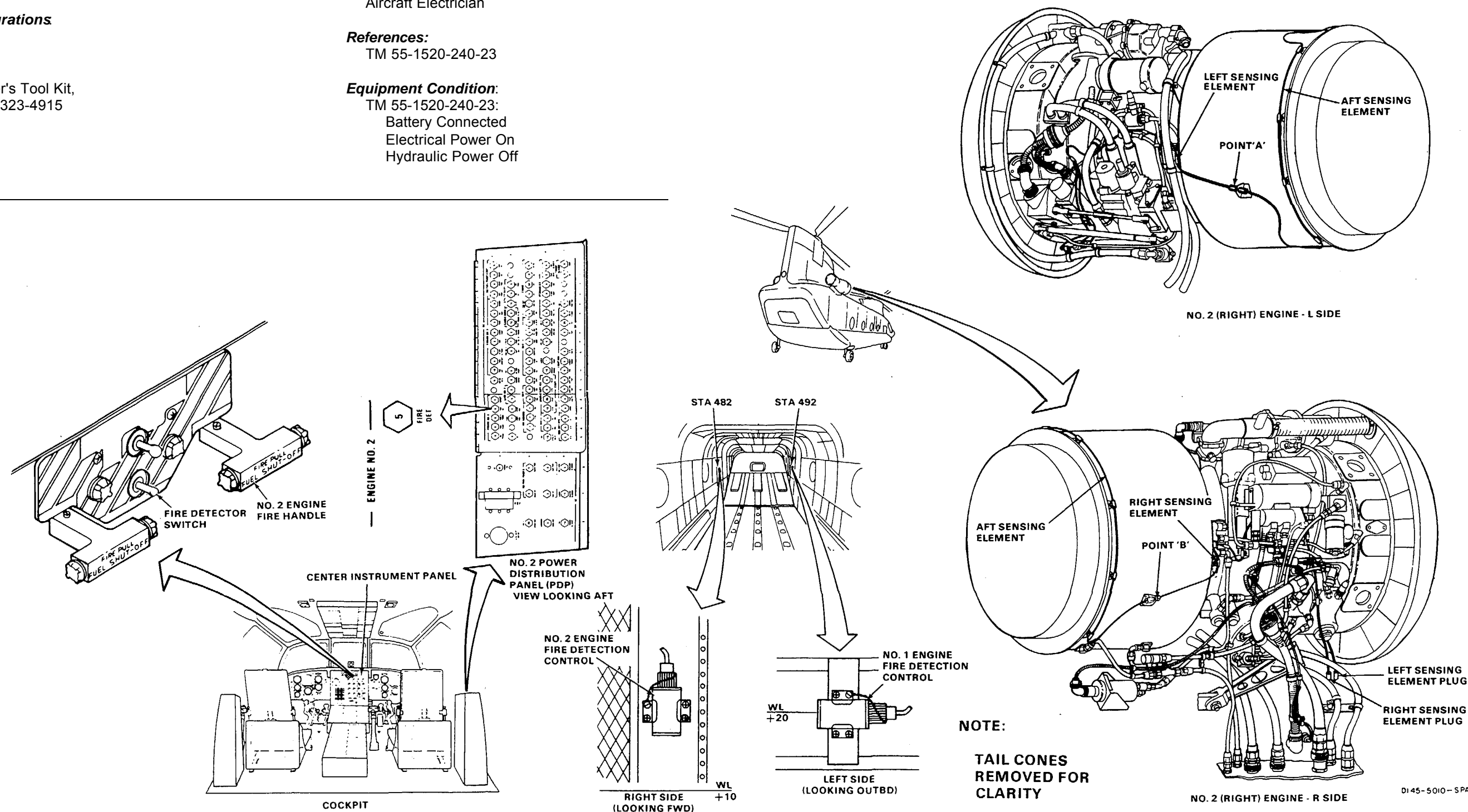

90 x 54

WITH 74

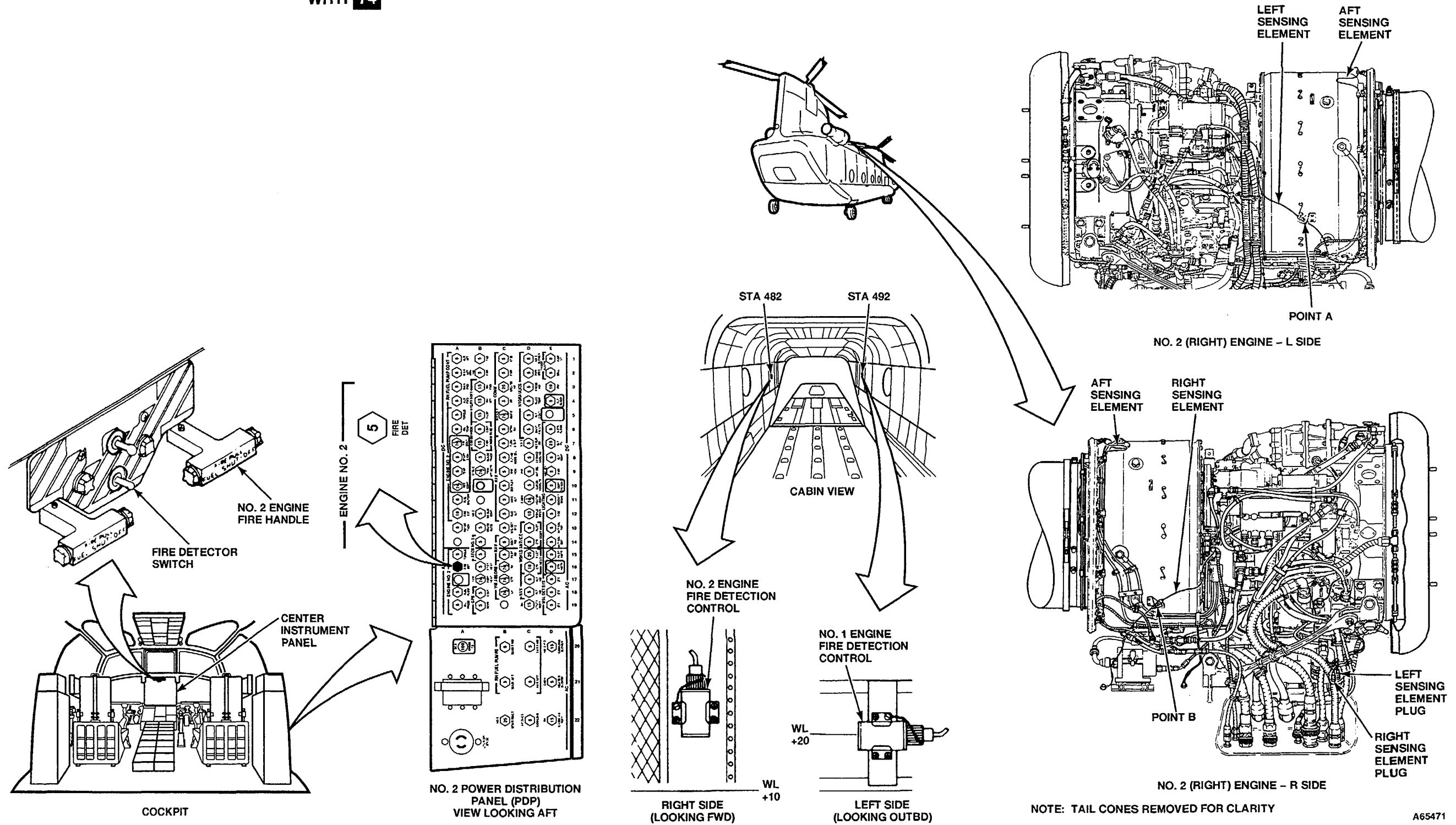

12-2.10 NO. 2 ENGINE FIRE HANDLE FIRE PULL/FUEL SHUTOFF
CAPTION DOES NOT LIGHT DURING TEST (Continued)

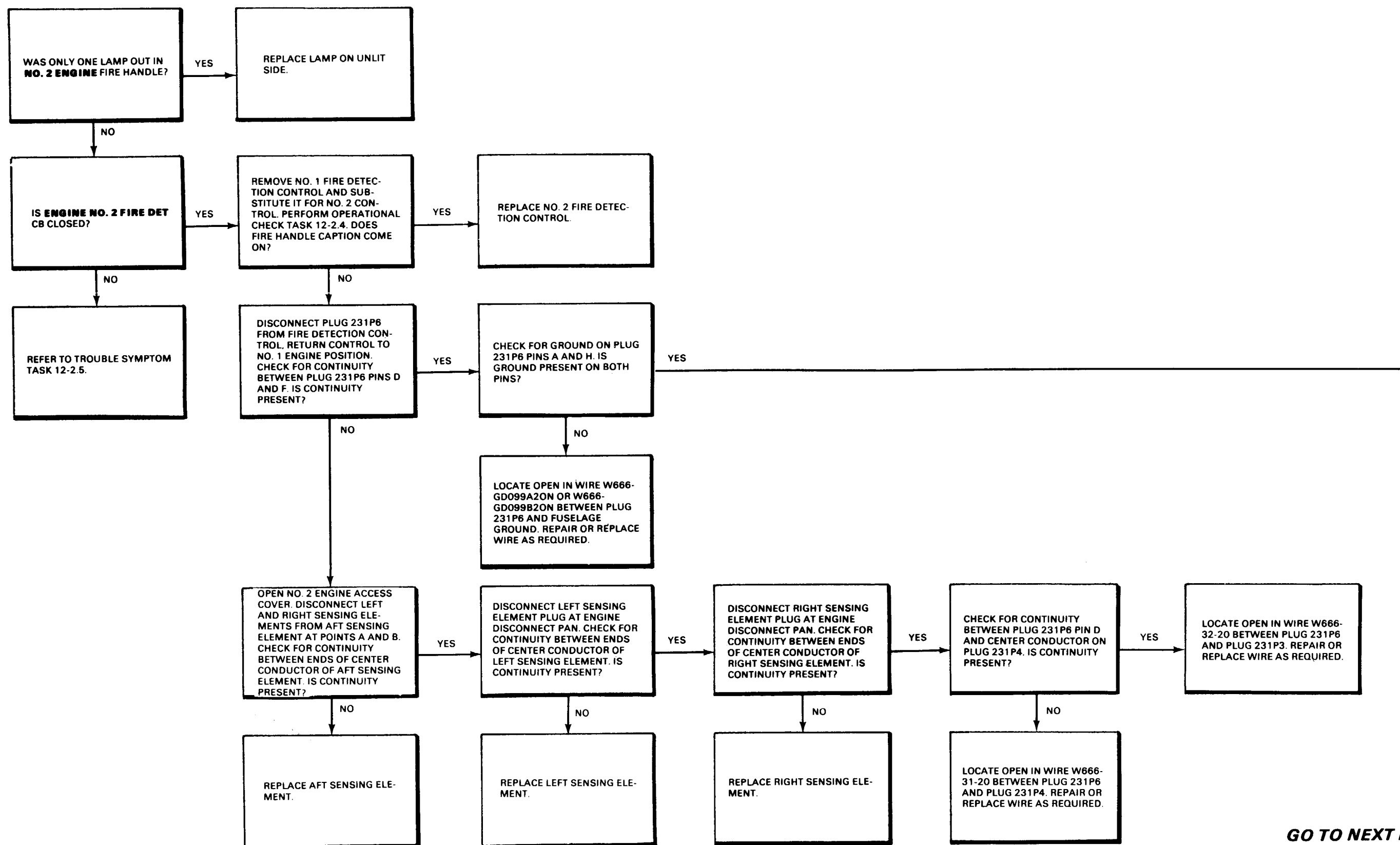

GO TO NEXT PAGE

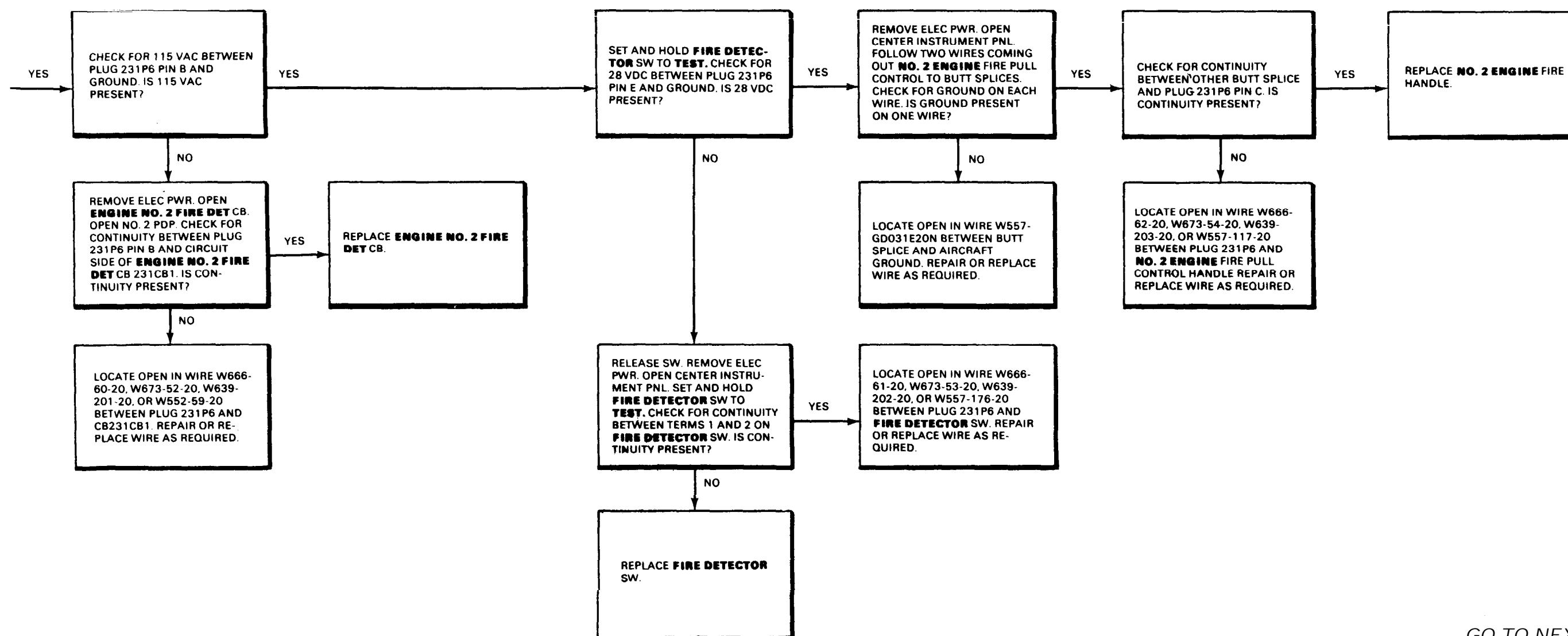

12-2.10 NO. 2 ENGINE FIRE HANDLE FIRE PULL/FUEL SHUTOFF
CAPTION DOES NOT LIGHT DURING TEST (Continued)

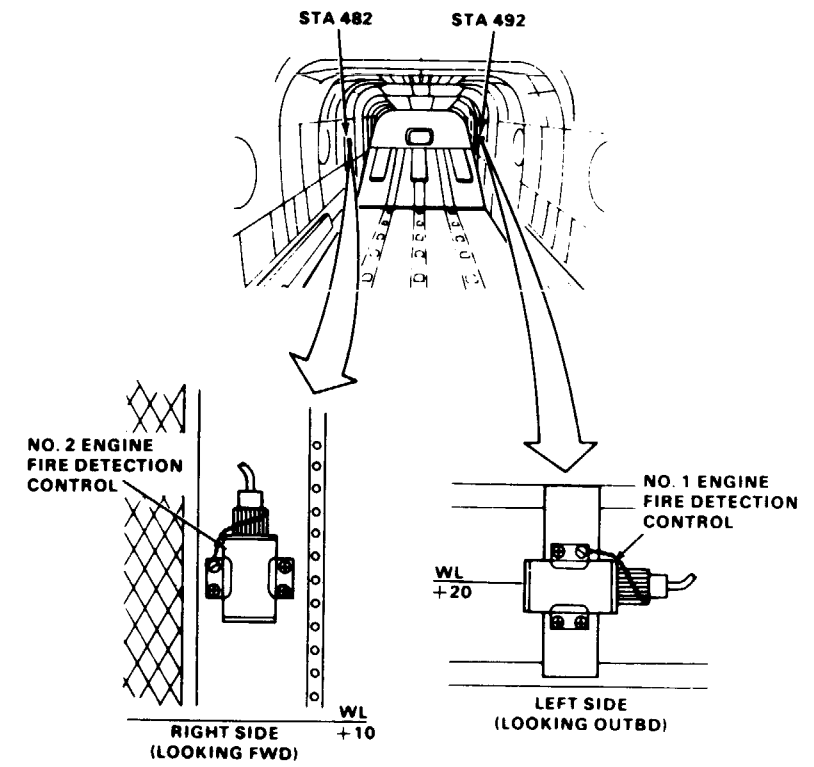
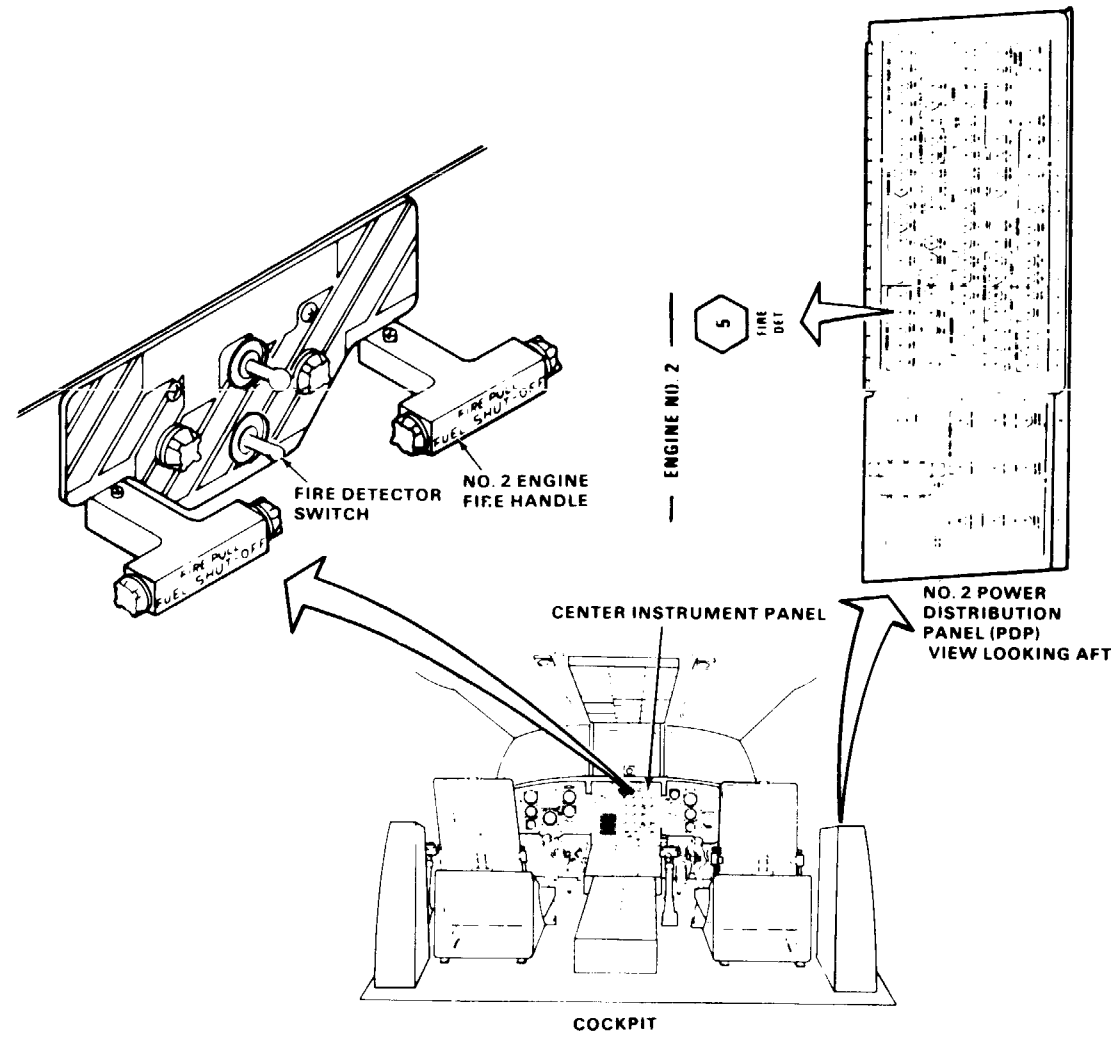

12-3 FIRE EXTINGUISHING SYSTEM

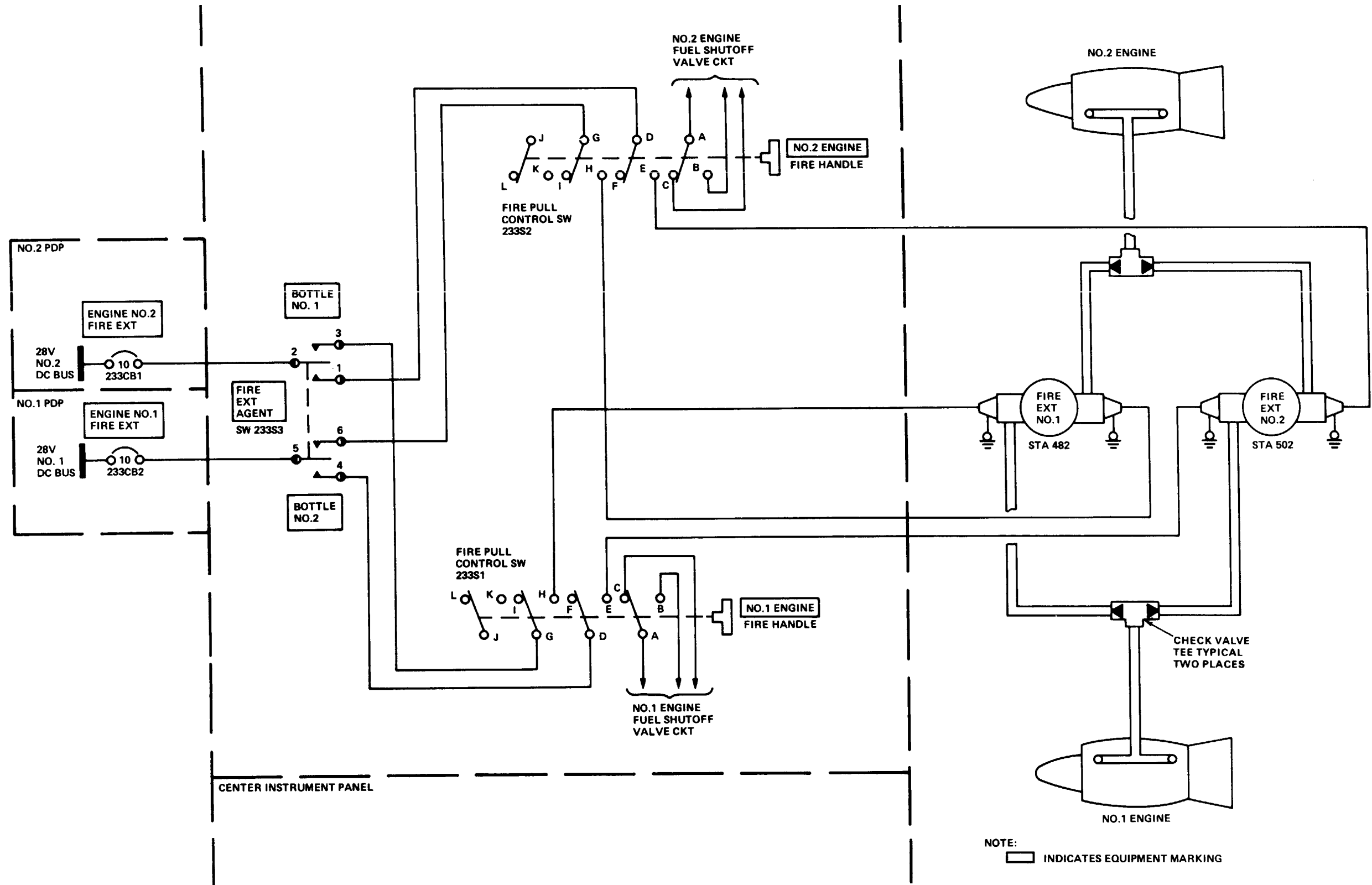

12-3.2 FIRE EXTINGUISHING SYSTEM WIRING DIAGRAM

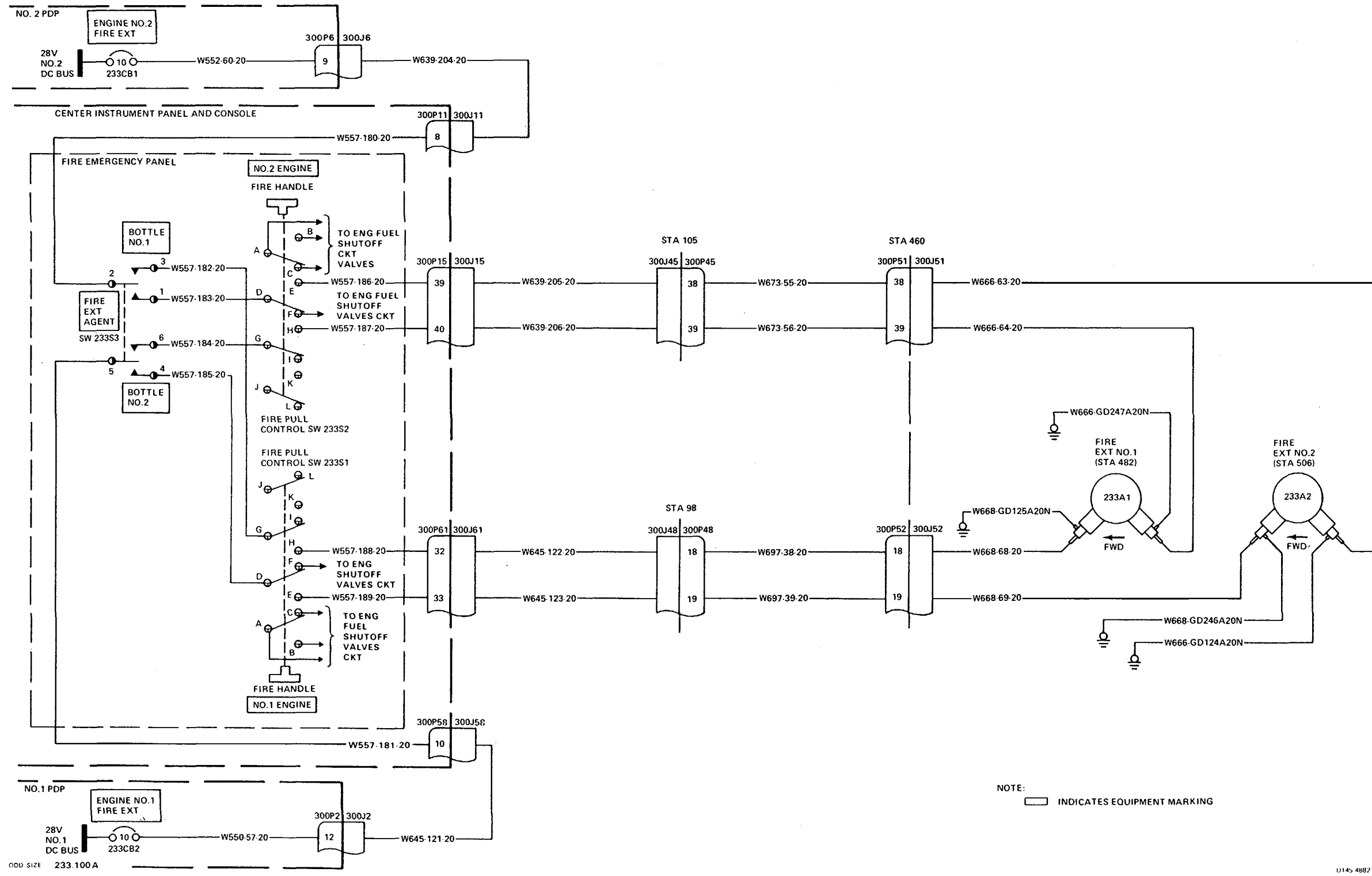

12-3.3 FIRE EXTINGUISHING SYSTEM VISUAL CHECK

INITIAL SETUP

Applicable Configurations:

All

Tools

Aircraft Mechanic's Tool Kit,
NSN 5180-00-323-4692

Materials:

None

Personnel Required:

Medium Helicopter Repairer

References:

TM 55-1520-240-23

Equipment Condition:

TM 55-1520-240-23:

Battery Disconnected
Electrical Power Off
Hydraulic Power Off

TASK	RESULT																				
1. Check FIRE EXT AGENT switch (1).	If switch (1) is loose or damaged, tighten or replace it as required.																				
2. Check NO. 1 ENGINE and NO. 2 ENGINE fire handles (2).	If either fire handle (2) is loose or damaged, tighten or replace it as required.																				
3. Check fire extinguisher (3).	If either fire extinguisher (3) is loose, tighten it. If wiring to cartridges (4) is damaged, repair or replace it as required.																				
4. Read gage (5) on each fire extinguisher (3).	If either gage (5) pressure reading is below following limits, replace fire bottle.																				
	<table border="0"> <tr> <td>Temperature</td> <td>Pressure</td> </tr> <tr> <td>-40°C (-40°F)</td> <td>292 - 370 psi</td> </tr> <tr> <td>-29°C (-40°F)</td> <td>320 - 400 psi</td> </tr> <tr> <td>-18°C (0°F)</td> <td>355 - 437 psi</td> </tr> <tr> <td>-7°C (19°F)</td> <td>396 - 486 psi</td> </tr> <tr> <td>4°C (39°F)</td> <td>449 - 540 psi</td> </tr> <tr> <td>15°C (59°F)</td> <td>518 - 618 psi</td> </tr> <tr> <td>27°C (81 °F)</td> <td>593 - 702 psi</td> </tr> <tr> <td>30°C (100°F)</td> <td>691 - 784 psi</td> </tr> <tr> <td>52°C (126°F)</td> <td>785 - 902 psi</td> </tr> </table>	Temperature	Pressure	-40°C (-40°F)	292 - 370 psi	-29°C (-40°F)	320 - 400 psi	-18°C (0°F)	355 - 437 psi	-7°C (19°F)	396 - 486 psi	4°C (39°F)	449 - 540 psi	15°C (59°F)	518 - 618 psi	27°C (81 °F)	593 - 702 psi	30°C (100°F)	691 - 784 psi	52°C (126°F)	785 - 902 psi
Temperature	Pressure																				
-40°C (-40°F)	292 - 370 psi																				
-29°C (-40°F)	320 - 400 psi																				
-18°C (0°F)	355 - 437 psi																				
-7°C (19°F)	396 - 486 psi																				
4°C (39°F)	449 - 540 psi																				
15°C (59°F)	518 - 618 psi																				
27°C (81 °F)	593 - 702 psi																				
30°C (100°F)	691 - 784 psi																				
52°C (126°F)	785 - 902 psi																				

FOLLOW-ON MAINTENANCE:

None

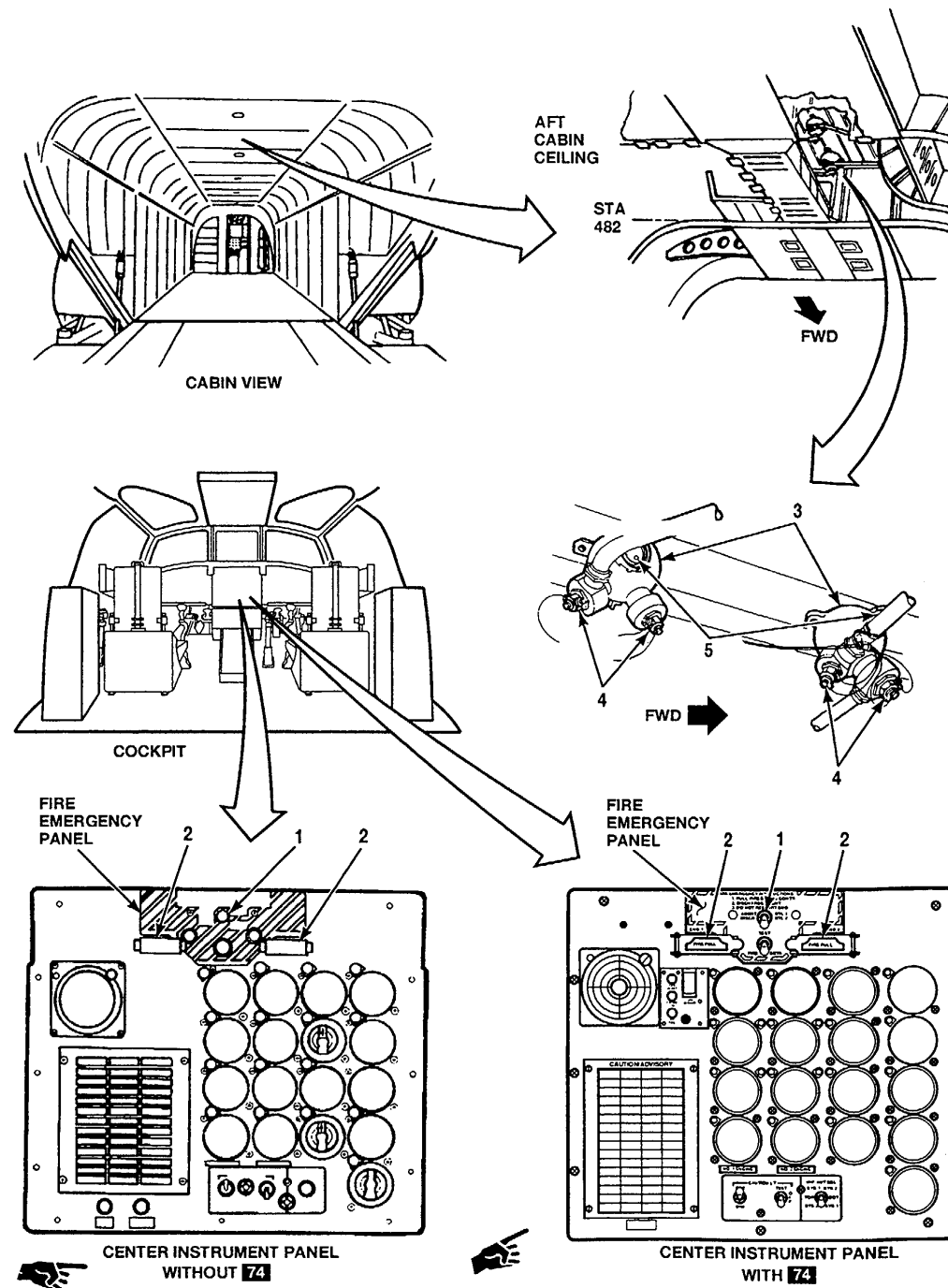

A65482

12-3.4 FIRE EXTINGUISHING SYSTEM OPERATIONAL CHECK

INITIAL SETUP

Applicable Configurations

All

Tools:

Multimeter

Materials

Paper Tags (E264)

Personnel Required:

Aircraft Electrician

References:

TM 55-1520-240-23

Equipment Condition:

TM 55-1520-240-23:

Battery Connected

Electrical Power On

Hydraulic Power Off

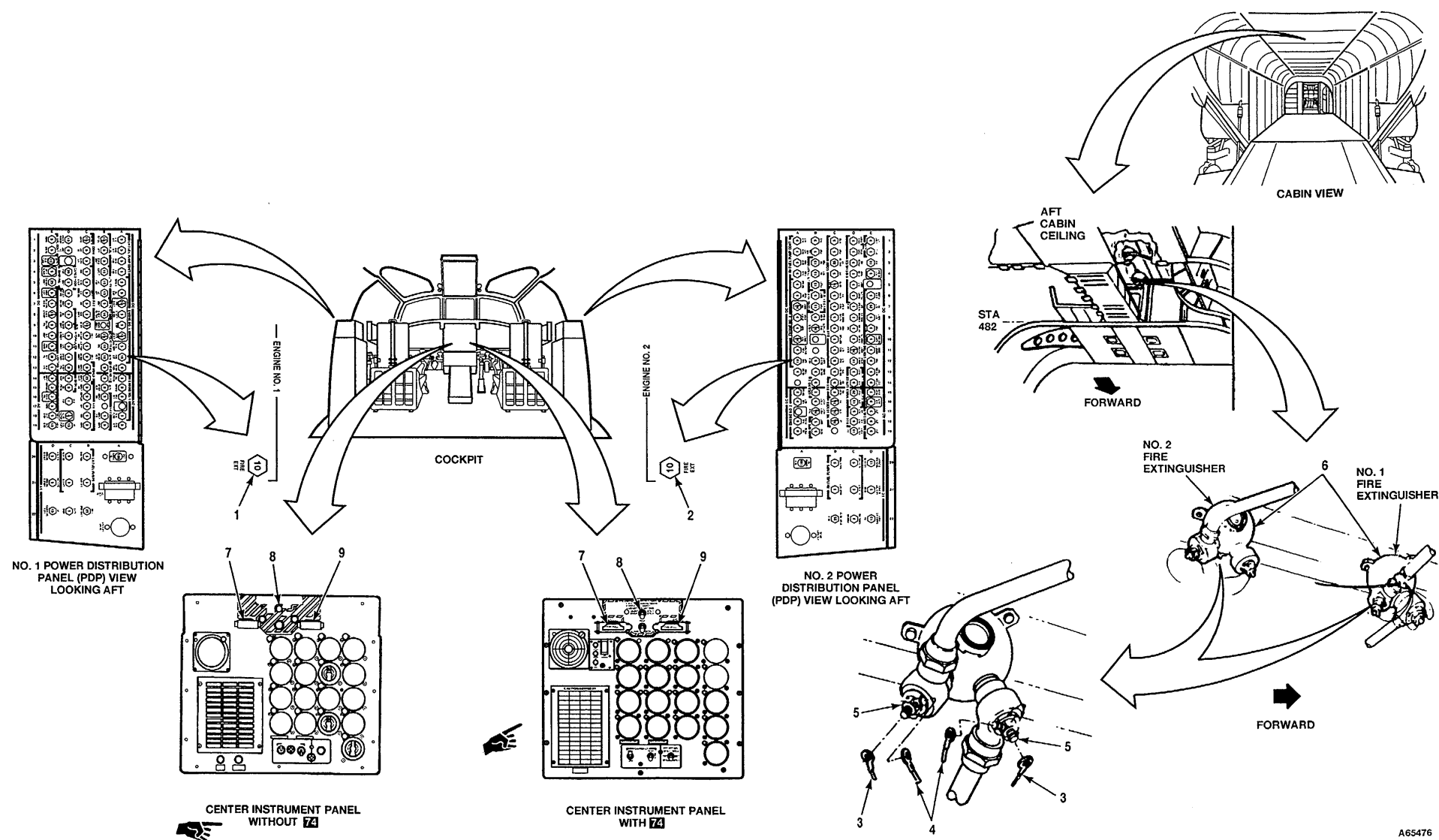

A65476

12-3.4 FIRE EXTINGUISHING SYSTEM OPERATIONAL CHECK (Continued)

12-3.4

TASK	RESULT	TASK	RESULT
<p>1. Check that ENGINE NO. 1 FIRE EXT circuit breaker (1) is closed.</p> <p>2. Check that ENGINE NO. 2 FIRE EXT circuit breaker (2) is closed.</p> <p>3. Tag and disconnect two wires (3 and 4) from each cartridge (5) on fire extinguishers (6).</p> <p style="text-align: center;">CAUTION</p> <p style="text-align: center;">Make sure wire terminal lugs do not touch cartridge terminals or fuselage. Aircraft damage or fire extinguisher discharge could occur.</p> <p style="text-align: center;">CAUTION</p> <p style="text-align: center;">Do not connect multimeter to cartridge. This could discharge extinguisher agent or reduce cartridge life.</p>	<p>If FIRE EXT circuit breaker (1) is open, close it. If it opens again, go to task 12-3.5.</p> <p>If FIRE EXT circuit breaker (2) is open, close it. If it opens again, go to task 12-3.5.</p>	<p>14. Set and hold FIRE EXT AGENT switch (8) to BOTTLE NO. 1.</p>	<p>Multimeter shall indicate <u>28 VDC</u>. If not, go to task 12-3.8. If voltage is present and trouble symptom. Fire extinguisher No. 1 did not discharge on No. 2 engine, was reported, replace aft cartridge (5) on No. 1 fire extinguisher (6).</p>
<p>4. Connect multimeter, set to measure 28 VDC, between wires W668-68-20(+) and W668-GD125A20N(-) at forward cartridge (5) on No. 1 fire extinguisher (6).</p> <p>5. Pull out NO. 1 ENGINE fire handle (7).</p> <p>6. Set and hold FIRE EXT AGENT switch (8) to BOTTLE NO. 1.</p>	<p>Multimeter shall indicate <u>28 VDC</u>. If not, go to task 12-3.6. If voltage is present and trouble symptom, Fire extinguisher No. 1 did not discharge on No. 1 engine, was reported, replace forward cartridge (5) on No. 1 fire extinguisher (6).</p>	<p>15. Release FIRE EXT AGENT switch (8).</p> <p>16. Disconnect multimeter. Connect multimeter to wire W666-63-20 (+) and W666-GD124A20N at aft cartridge (5) on No. 2 fire extinguisher (6).</p> <p>17. Set and hold FIRE EXT AGENT switch (8) to BOTTLE NO. 2.</p>	<p>Multimeter shall indicate <u>28 VDC</u>. If not, go to task 12-3.9. If voltage is present and trouble symptom. Fire extinguisher No. 2 did not discharge on No. 2 engine, was reported, replace aft cartridge (5) on No. 2 fire extinguisher (6).</p>
<p>7. Release FIRE EXT AGENT switch (8).</p> <p>8. Disconnect multimeter. Connect multimeter to wires W668-69-20 (+) and W668-GD246A20N (-) at forward cartridge (5) on No. 2 fire extinguisher (6).</p> <p>9. Set and hold FIRE EXT AGENT switch (8) to BOTTLE NO. 2.</p>	<p>Multimeter shall indicate <u>28 VDC</u>. If not, go to task 12-3.7. If voltage is present and trouble symptom, Fire extinguisher No. 2 did not discharge on No. 1 engine, was reported, replace forward cartridge (5) on No. 2 fire extinguisher (6).</p>	<p>18. Release FIRE EXT AGENT switch (8).</p> <p>19. Push in NO. 2 ENGINE fire handle (9).</p> <p style="text-align: center;">CAUTION</p> <p style="text-align: center;">Insure wires are connected to right terminals on cartridge. Reverse connections will prevent agent release when a fire occurs. Ground wire must be connected to terminal on side of cartridge.</p> <p>20. Connect two wires (3 and 4) to each cartridge (5) on fire extinguishers (6). See tags and wiring diagram (12-3.2). Remove tags.</p>	
<p>10. Release FIRE EXT AGENT switch (8).</p> <p>11. Push in NO. 1 ENGINE fire handle (7).</p> <p>12. Pull out NO. 2 ENGINE fire handle (9).</p> <p>13. Disconnect multimeter. Connect multimeter to wires W666-64-20 (+) and W666-GD247A20N at aft cartridge (5) on No. 1 fire extinguisher (6).</p>		<p>FOLLOW-ON MAINTENANCE: Perform operational check of engine fuel shutoff valves. TM 55-1520-240-23: Battery Disconnected Electrical Power Off</p>	

END OF TASK

12-3.5 FIRE EXT CIRCUIT BREAKER WILL NOT STAY CLOSED

FAULT ISOLATION PROCEDURE

INITIAL SETUP

Applicable Configurations

All

Tools

Electrical Repairer's Tool Kit,
NSN 5180-00-323-4915
Multimeter

Materials

None

Personnel Required:
Aircraft Electrician

References
TM 55-1520-240-23

Equipment Condition:
TM 55-1520-240-23:
Battery Disconnected
Electrical Power Off
Hydraulic Power Off

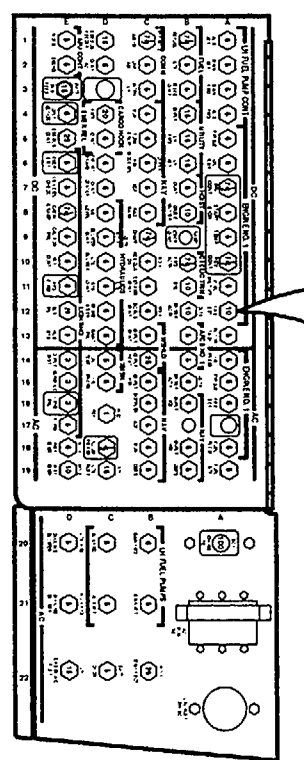

NO. 1 POWER DISTRIBUTION PANEL (PDP) VIEW LOOKING AFT

ENGINE NO. 1

10 FIRE EXT

FIRE EXT AGENT SWITCH

FIRE EMERGENCY PANEL

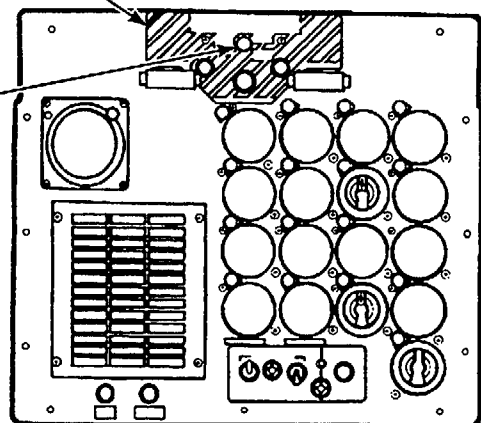

CENTER INSTRUMENT PANEL WITHOUT 74

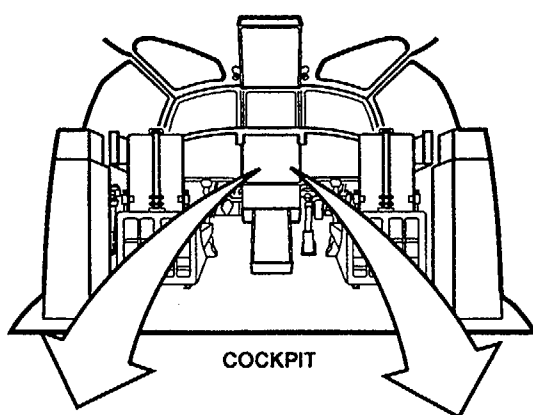

COCKPIT

FIRE EXT AGENT SWITCH
FIRE EMERGENCY PANEL

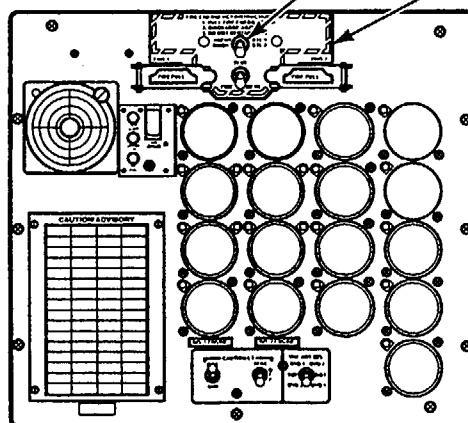

CENTER INSTRUMENT PANEL WITH 74

ENGINE NO. 2

10 FIRE EXT

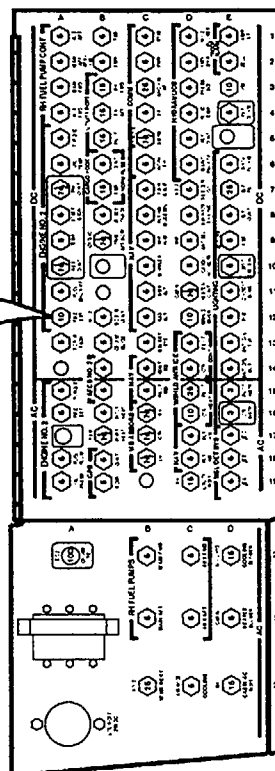

NO. 2 POWER DISTRIBUTION PANEL (PDP) VIEW LOOKING AFT

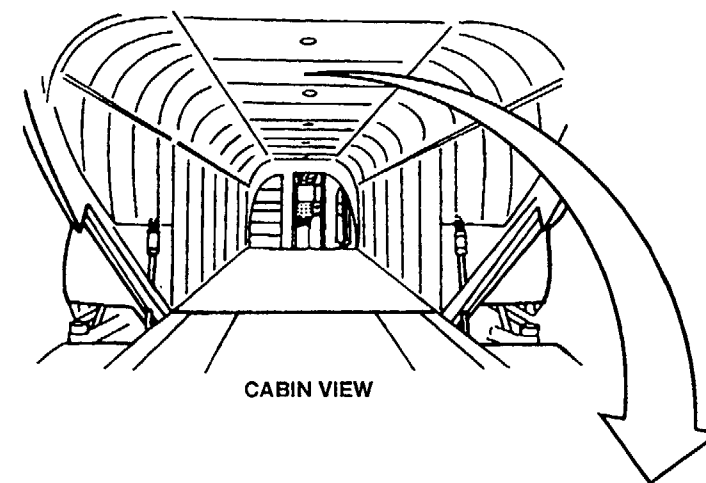

CABIN VIEW

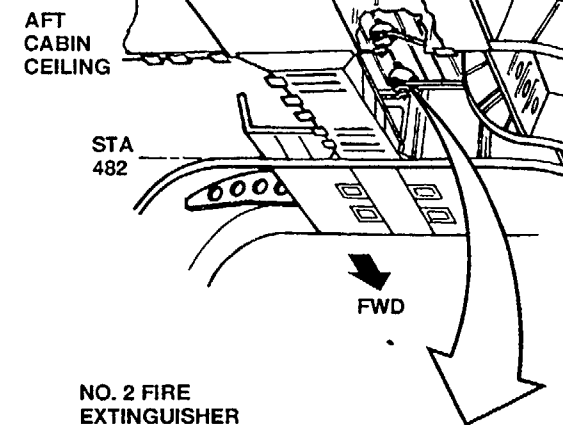

AFT CABIN CEILING

STA 482

FWD

NO. 2 FIRE EXTINGUISHER

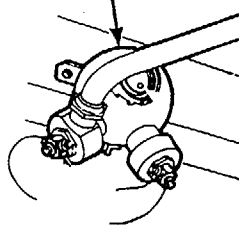

FWD

NO. 1 FIRE EXTINGUISHER

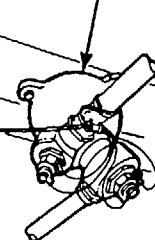

12-3.5 FIRE EXT CIRCUIT BREAKER WILL NOT STAY CLOSED

(Continued)

ENGINE NO. 1 FIRE EXT CIRCUIT BREAKER WILL NOT STAY CLOSED

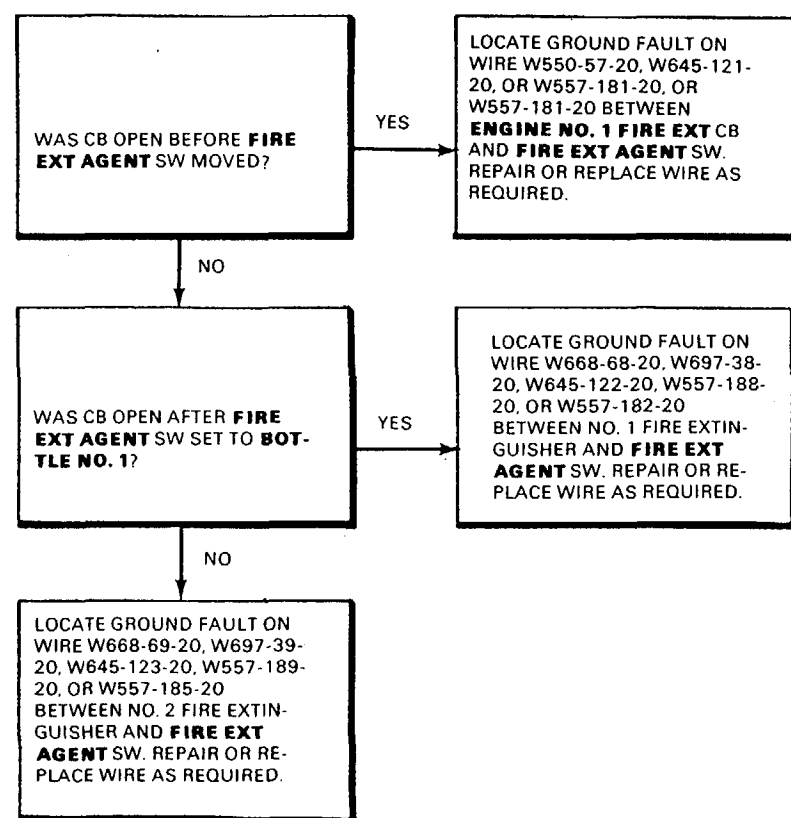

ENGINE NO. 2 FIRE EXT CIRCUIT BREAKER WILL NOT STAY CLOSED

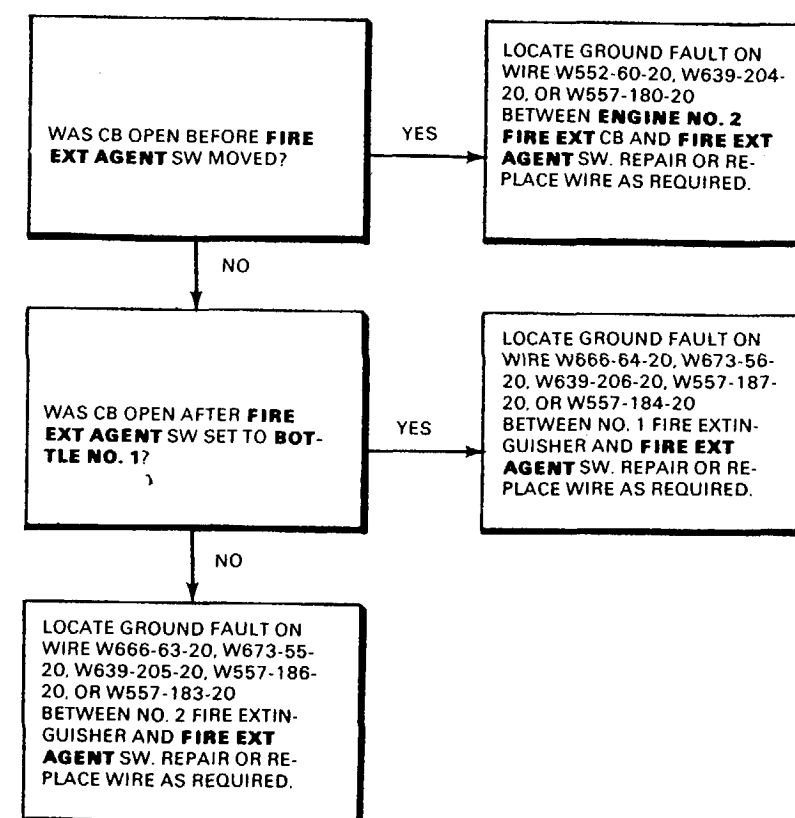

END OF TASK

12-3.6 MULTIMETER DOES NOT INDICATE 28 VDC WITH NO. 1 ENGINE FIRE HANDLE OUT AND FIRE EXT AGENT SWITCH AT BOTTLE NO. 1

FAULT ISOLATION PROCEDURE

INITIAL SETUP

Applicable Configurations

All

Tools

Electrical Repairer's Tool Kit,
NSN 5180-00-323-4915
Multimeter

Materials

None

Personnel Required:
Aircraft Electrician (2)

References
TM 55-1520-240-23

Equipment Condition:
TM 55-1520-240-23:
Battery Connected
Electrical Power On
Hydraulic Power Off

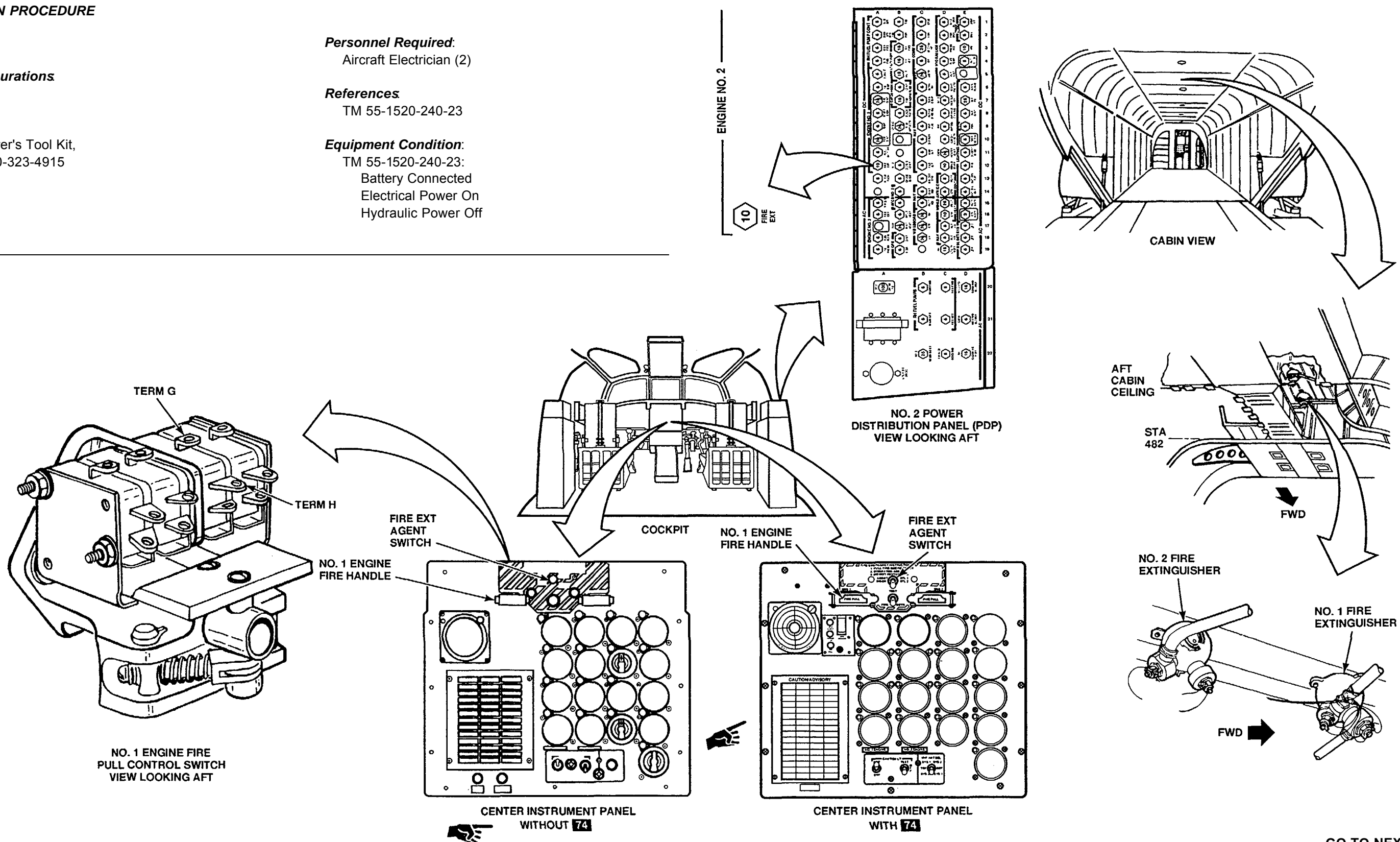

12-3.6 MULTIMETER DOES NOT INDICATE 28 VDC WITH NO. 1 ENGINE FIRE HANDLE OUT AND FIRE EXT AGENT SWITCH AT BOTTLE NO. 1 (Continued)

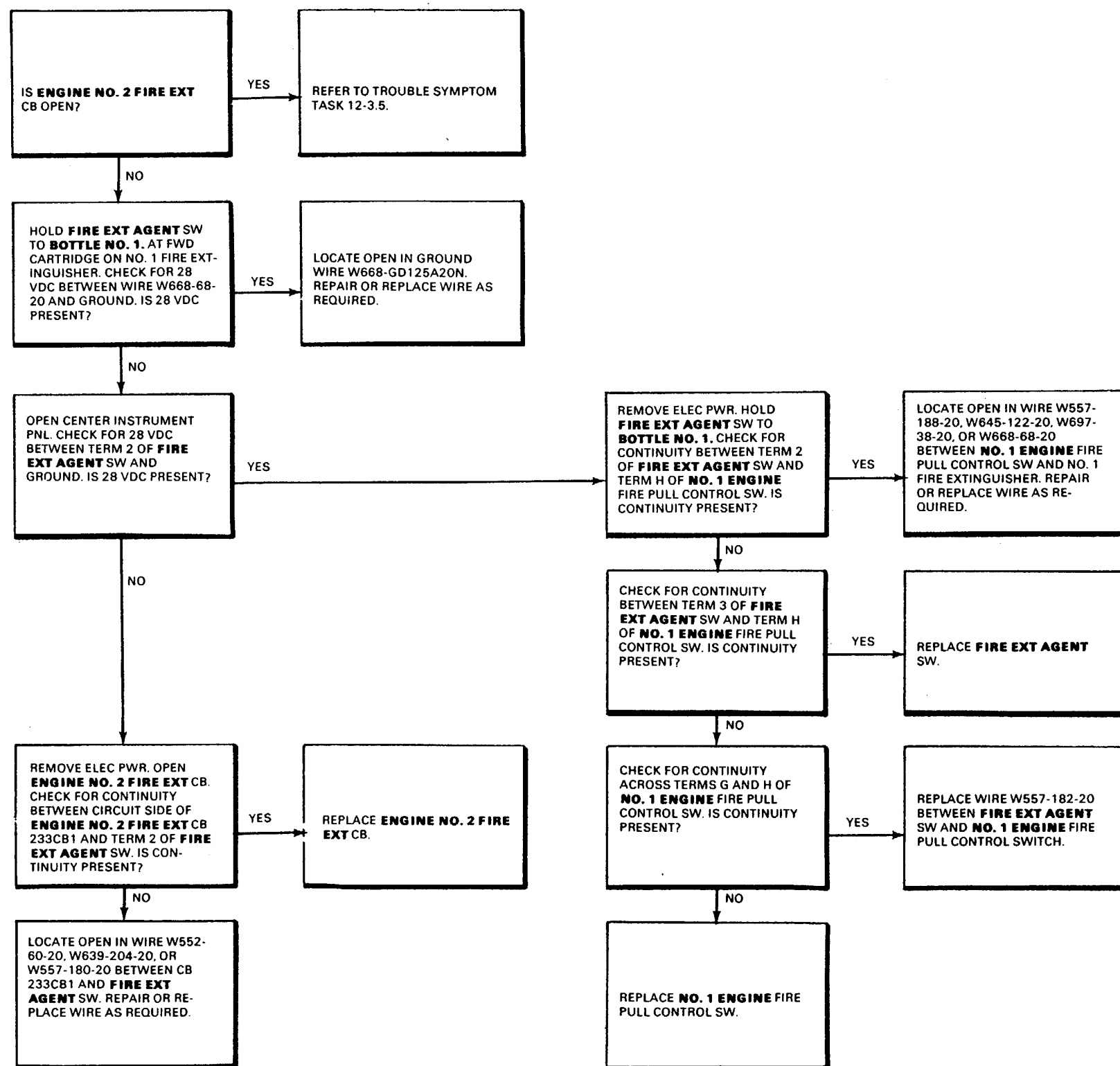

END OF TASK

12-3.7 MULTIMETER DOES NOT INDICATE 28 VDC WITH NO. 1 ENGINE FIRE HANDLE OUT AND FIRE EXT AGENT SWITCH AT BOTTLE NO. 2

FAULT ISOLATION PROCEDURE

INITIAL SETUP

Applicable Configurations

All

Tools

Electrical Repairer's Tool Kit,
NSN 5180-00-323-4915
Multimeter

Materials

None

Personnel Required:
Aircraft Electrician (2)

References
TM 55-1520-240-23

Equipment Condition:
TM 55-1520-240-23:
Battery Connected
Electrical Power On
Hydraulic Power Off

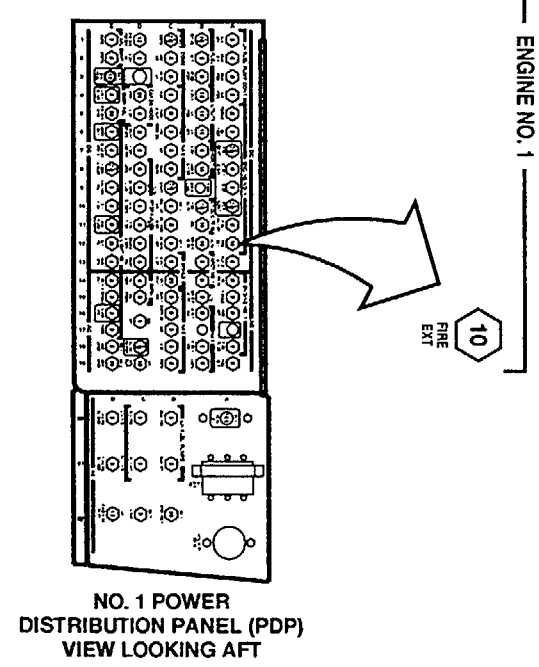
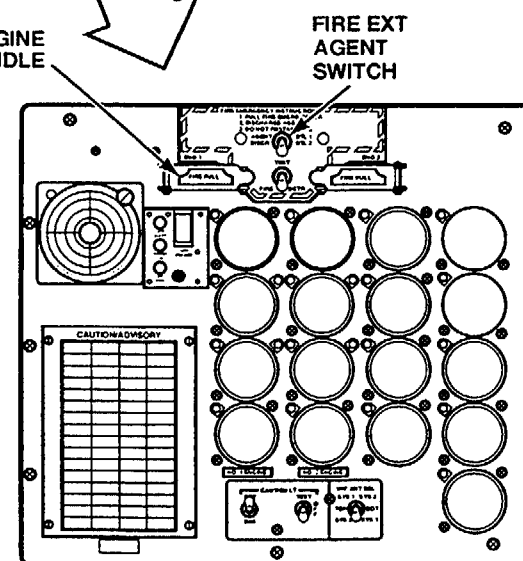
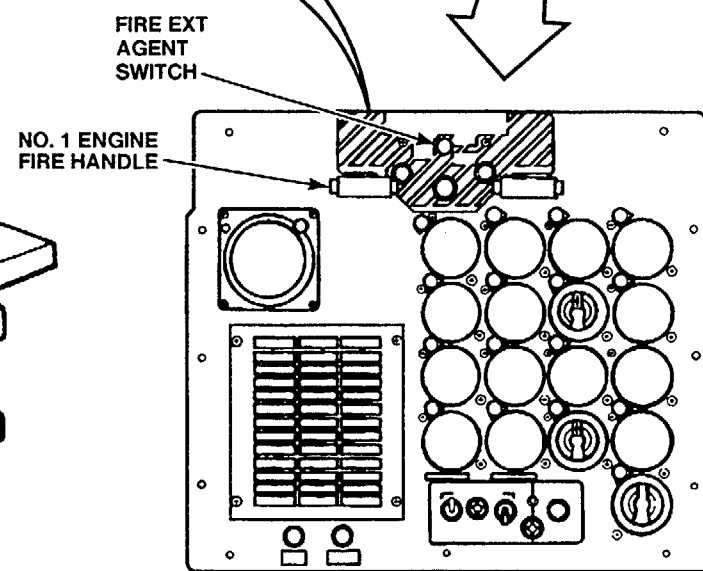
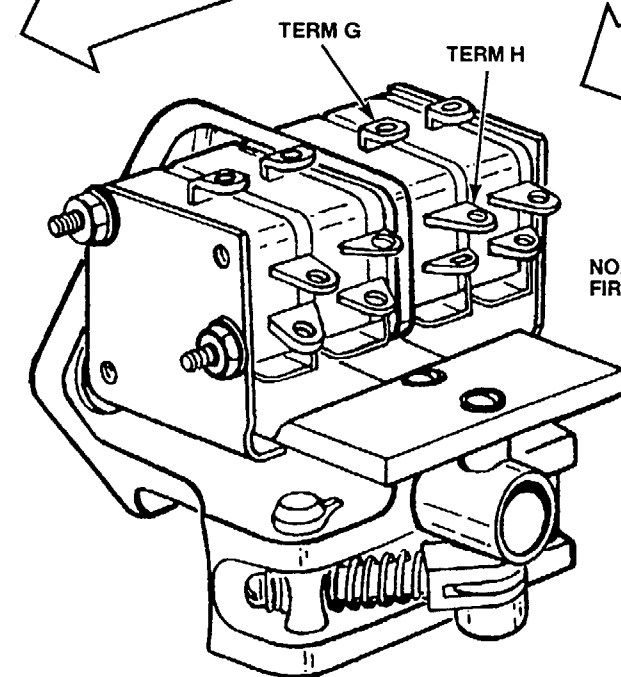
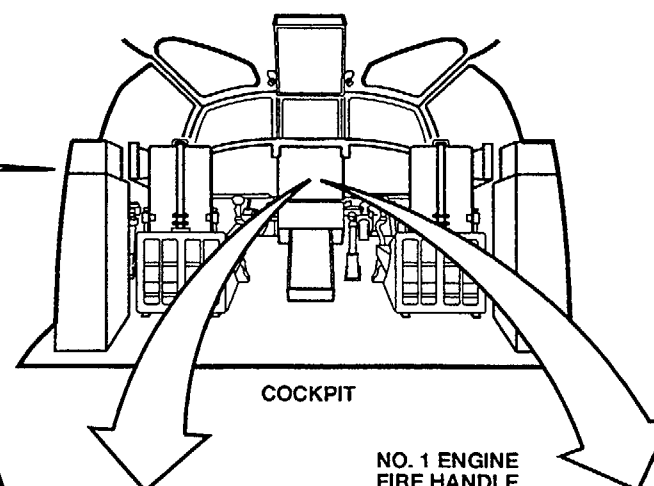
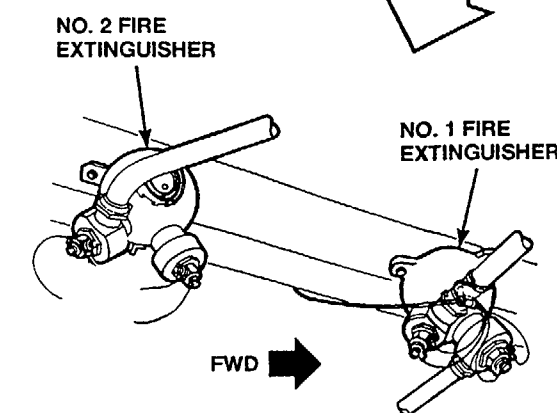
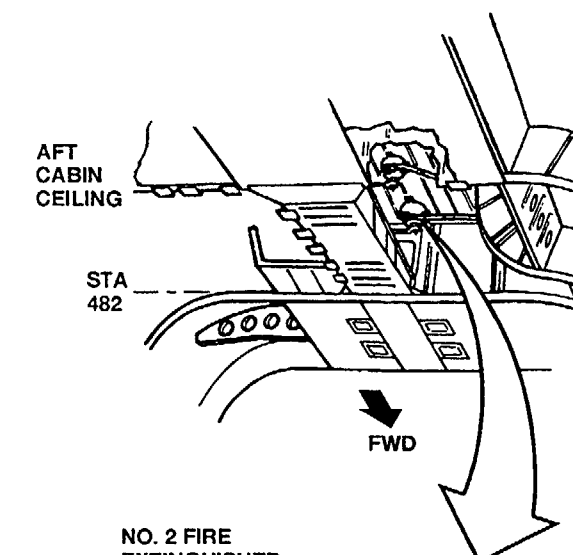
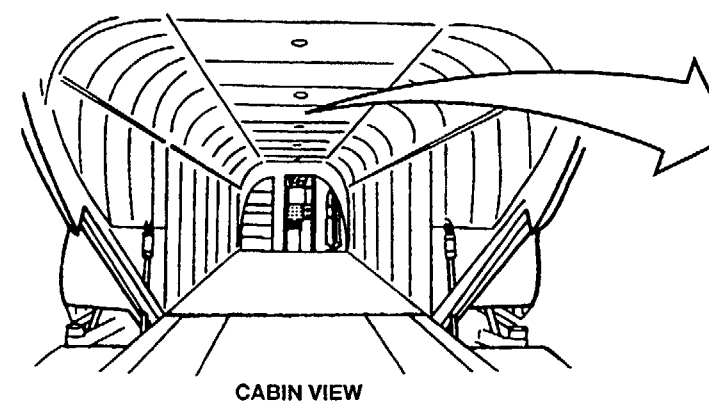

12-3.7 MULTIMETER DOES NOT INDICATE 28 VDC WITH NO.1 ENGINE FIRE HANDLE OUT AND FIRE EXT AGENT SWITCH AT BOTTLE NO. 2 (Continued)

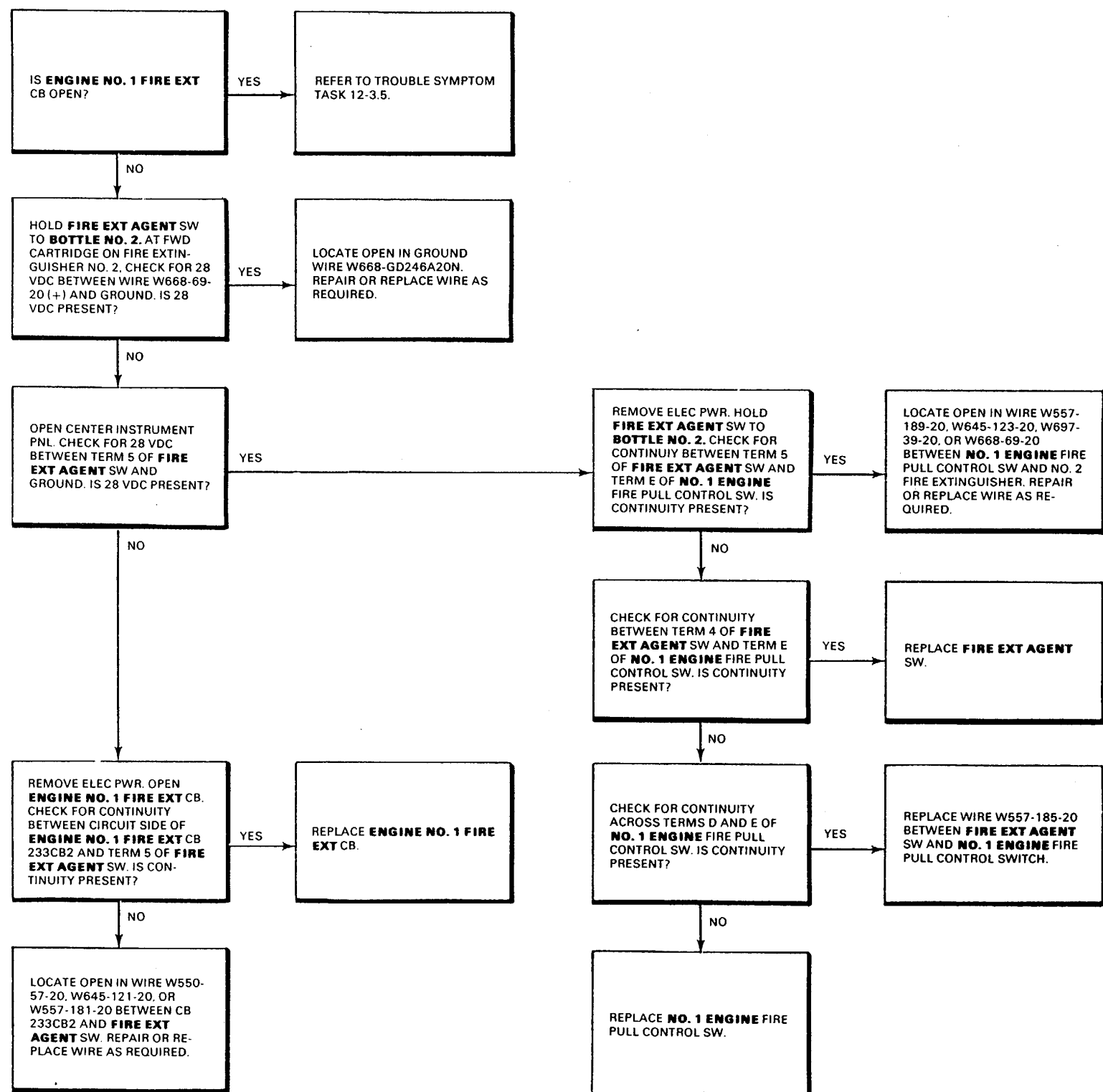

END OF TASK

12-3.8 MULTIMETER DOES NOT INDICATE 28 VDC WITH NO. 2 ENGINE FIRE HANDLE OUT AND FIRE EXT AGENT SWITCH AT BOTTLE NO. 1

FAULT ISOLATION PROCEDURE

INITIAL SETUP

Applicable Configurations

All

Tools

Electrical Repairer's Tool Kit,
NSN 5180-00-323-4915
Multimeter

Materials

None

Personnel Required:
Aircraft Electrician (2)

References
TM 55-1520-240-23

Equipment Condition:
TM 55-1520-240-23:
Battery Connected
Electrical Power On
Hydraulic Power Off

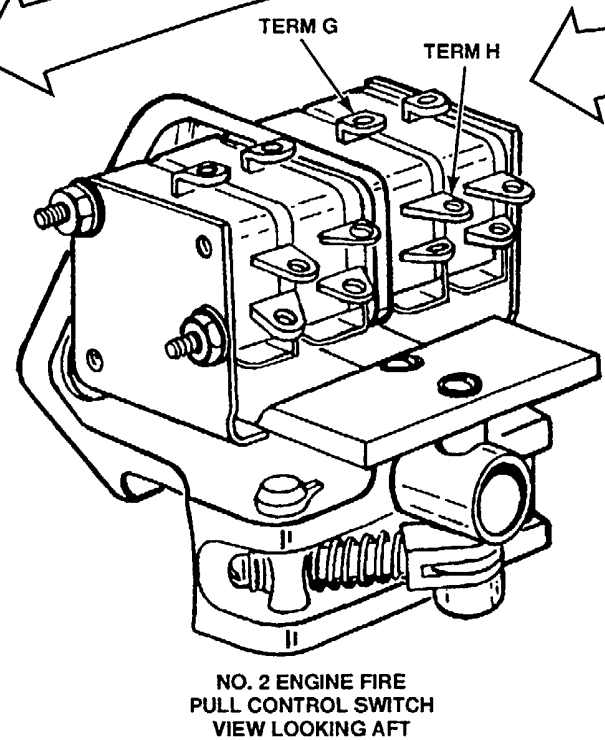
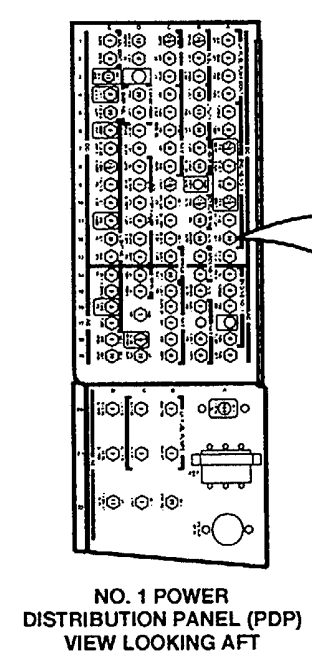
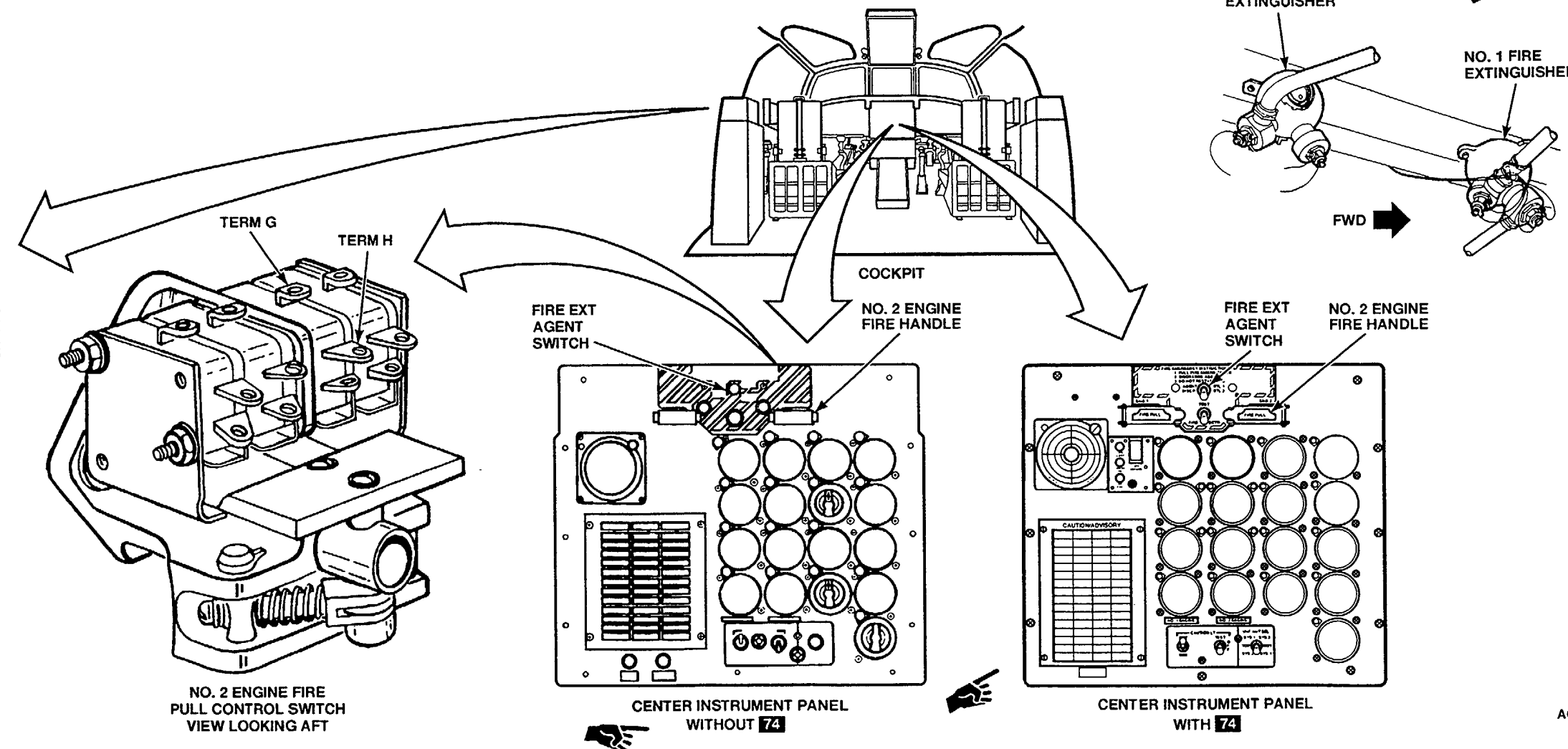
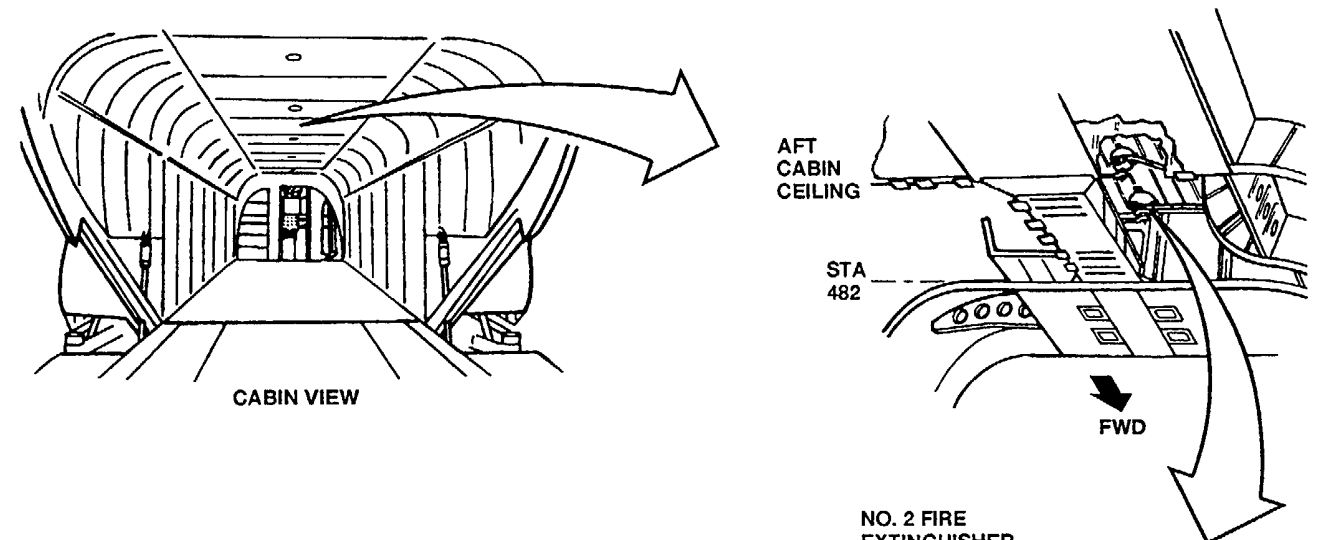

12-3.8 MULTIMETER DOES NOT INDICATE 28 VDC WITH NO. 2 ENGINE FIRE HANDLE OUT AND FIRE EXT AGENT SWITCH AT BOTTLE NO. 1 (Continued)

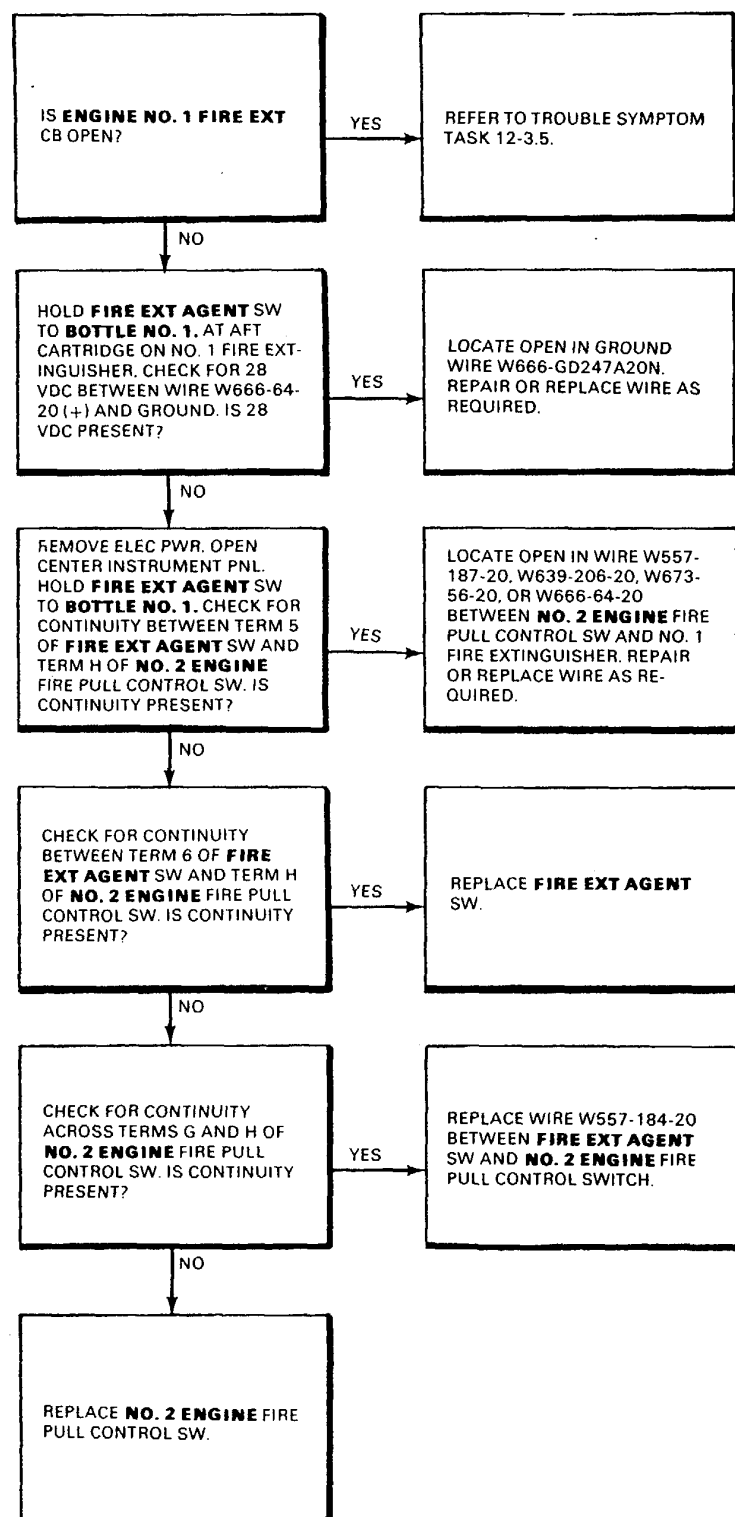

END OF TASK

12-3.9 MULTIMETER DOES NOT INDICATE 28 VDC WITH NO. 2 ENGINE FIRE HANDLE OUT AND FIRE EXT AGENT SWITCH AT BOTTLE NO. 2

FAULT ISOLATION PROCEDURE

INITIAL SETUP

Applicable Configurations

All

Tools

Electrical Repairer's Tool Kit,
NSN 5180-00-323-4915
Multimeter

Materials

None

Personnel Required:
Aircraft Electrician (2)

References
TM 55-1520-240-23

Equipment Condition:
TM 55-1520-240-23:
Battery Connected
Electrical Power On
Hydraulic Power Off

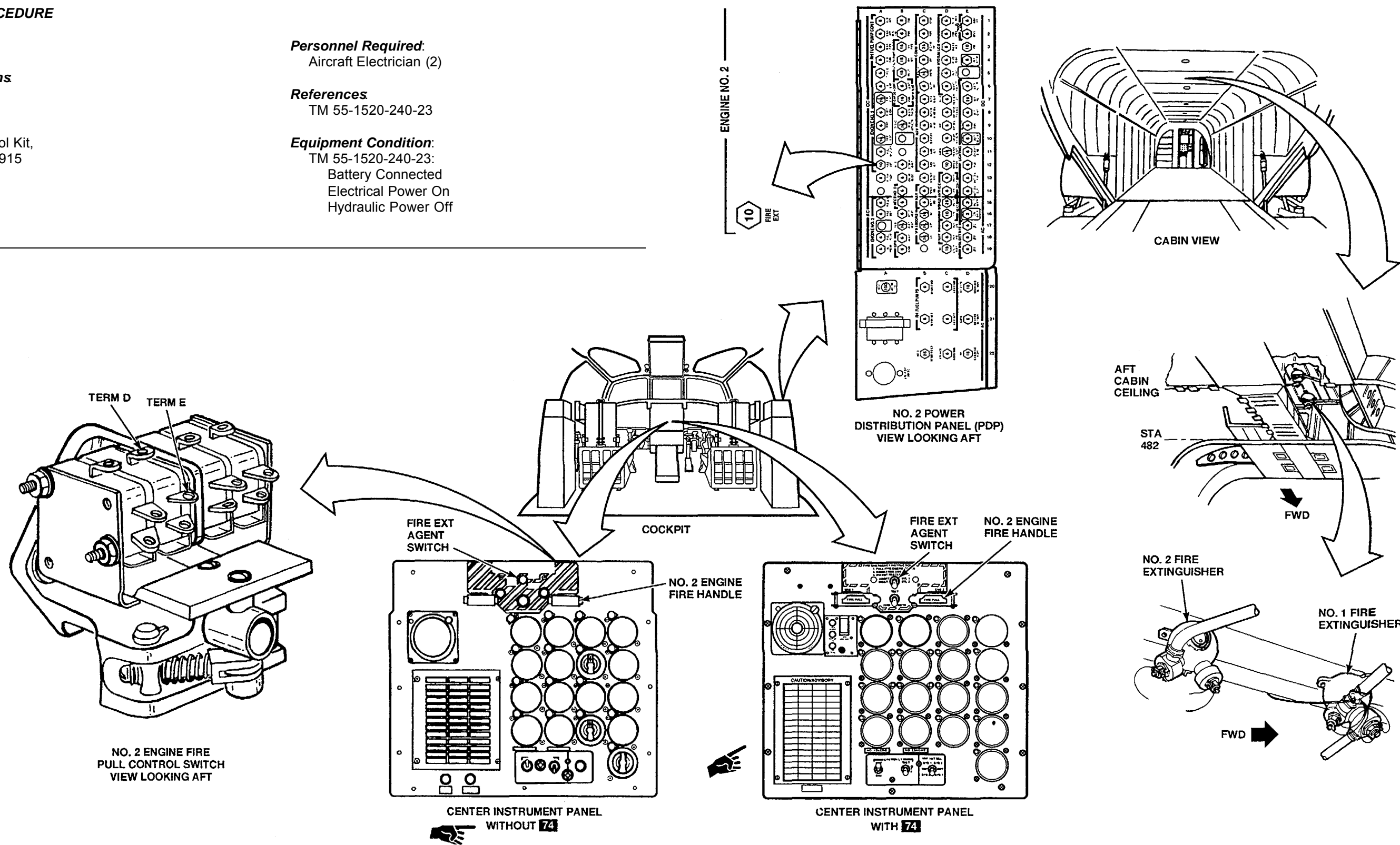

12-3.9 MULTIMETER DOES NOT INDICATE 28 VDC WITH NO. 2 ENGINE FIRE HANDLE OUT AND FIRE EXTAGENT SWITCH AT BOTTLE NO. 2 (Continued)

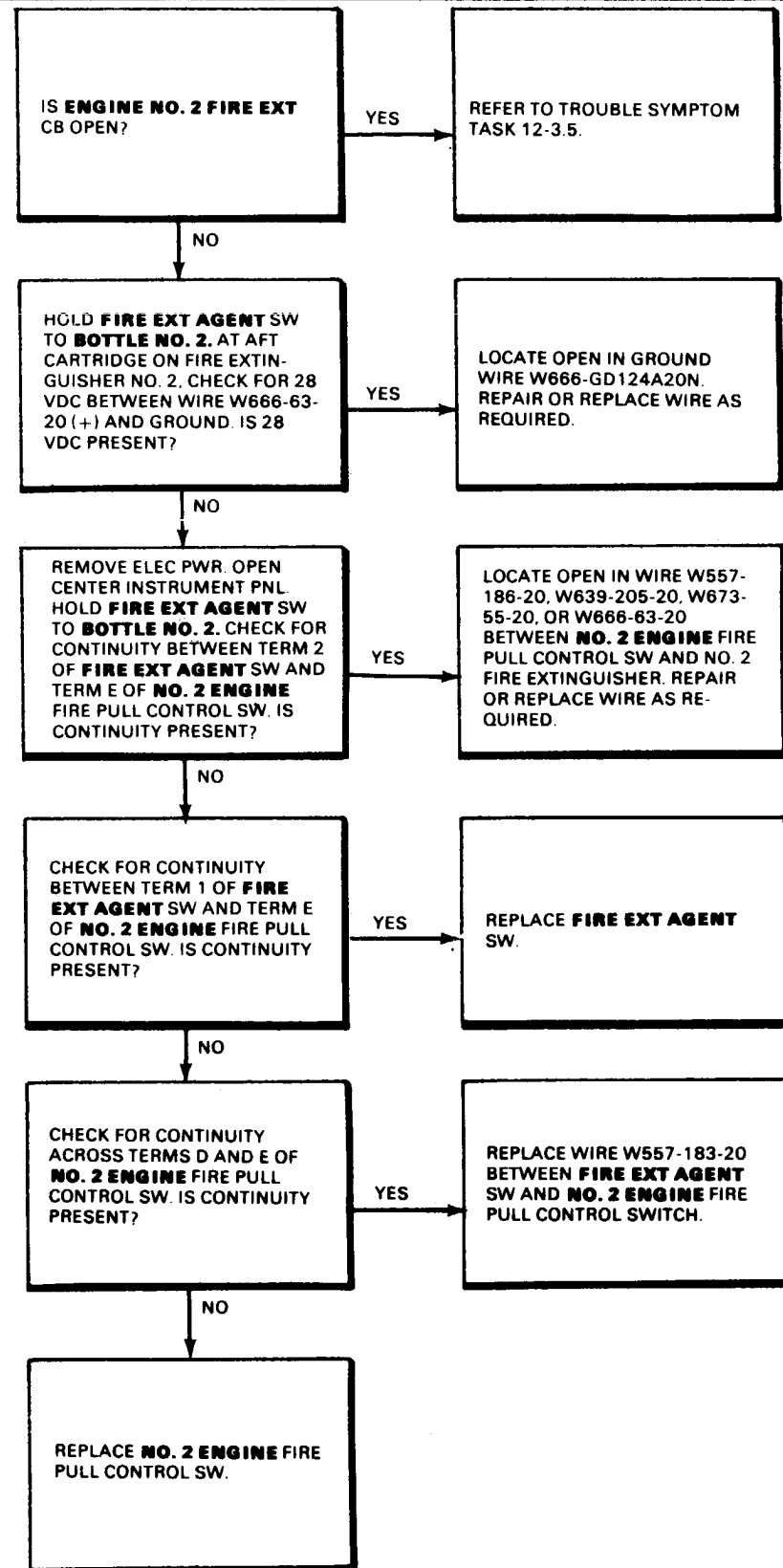

END OF TASK

12-4 WINDSHIELD WIPERS

12-4 WINDSHIELD WIPERS

12-4.1 WINDSHIELD WIPERS WIRING DIAGRAM

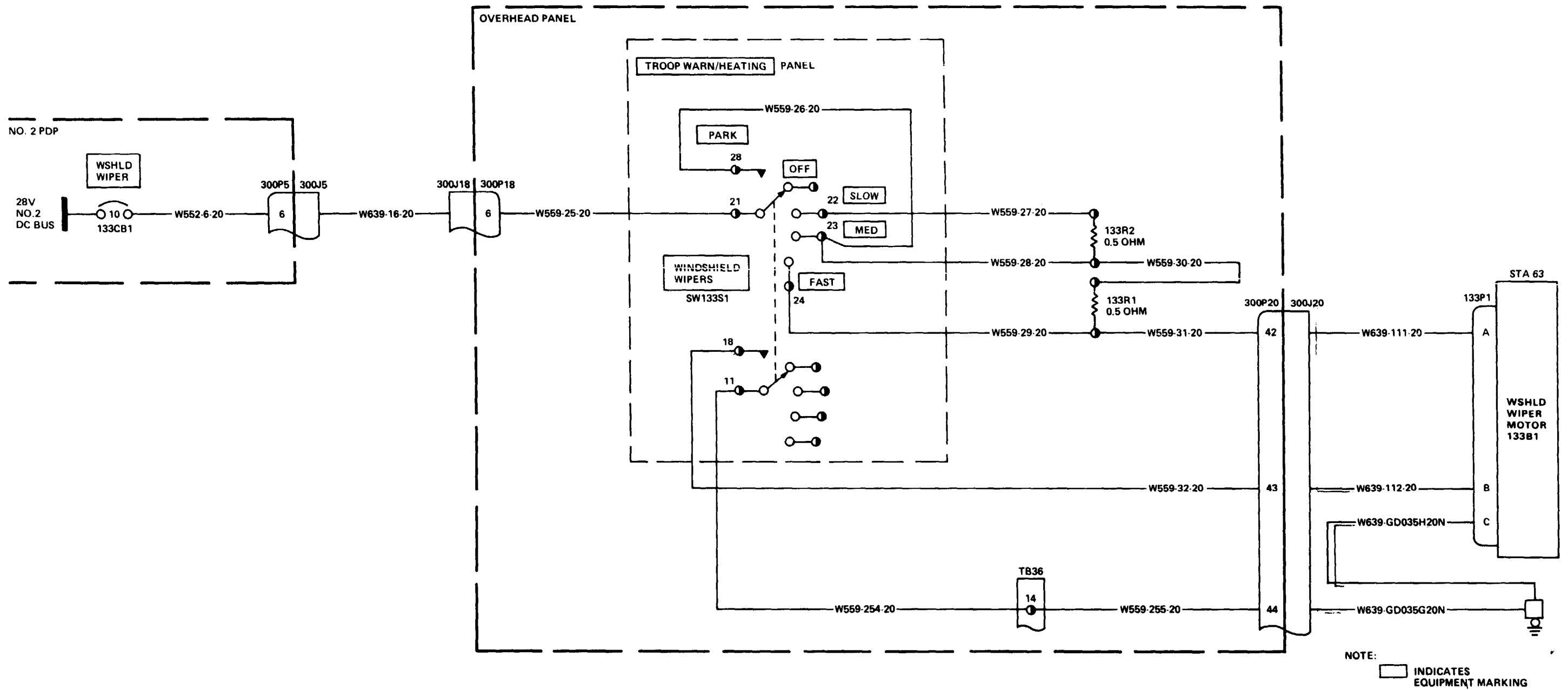

12-4.2 WINDSHIELD WIPERS VISUAL CHECK

12-4.2

INITIAL SETUP

Applicable Configurations:
All

Tools:
Aircraft Mechanic's Tool Kit,
NSN 5180-00-323-4692
Work Stand

Materials:
None

Personnel Required:
67U10 Medium Helicopter Repairer

References:
TM 55-1520-240-23

Equipment Condition:
TM 55-1520-240-23:
Battery Disconnected
Electrical Power Off
Hydraulic Off

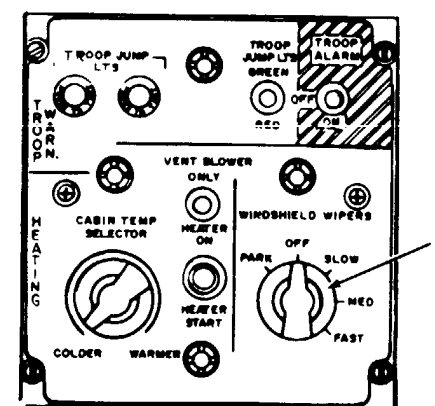
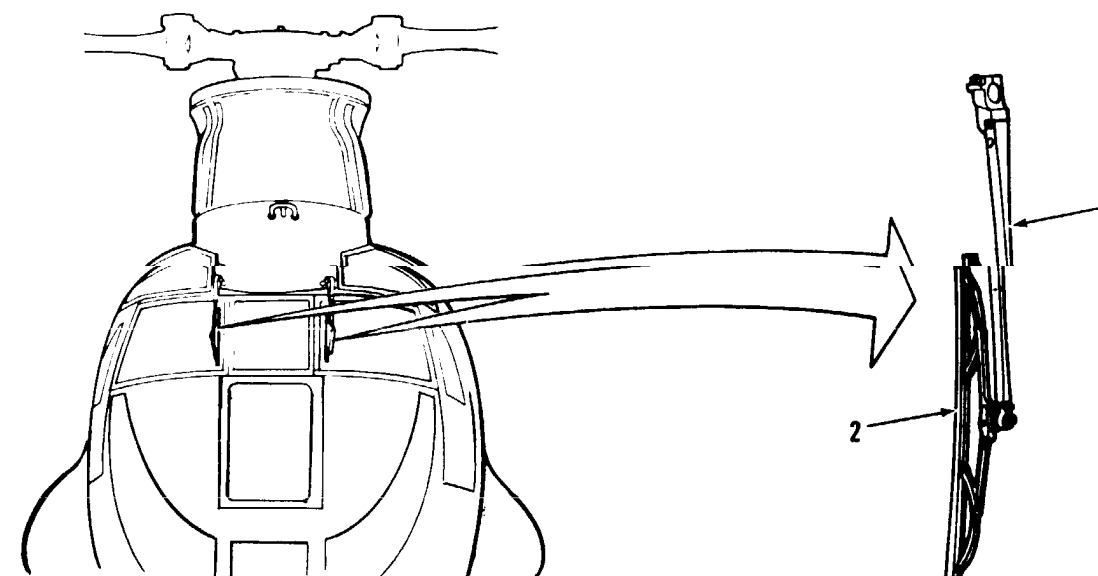

TROOP WARN/
HEATING PANEL

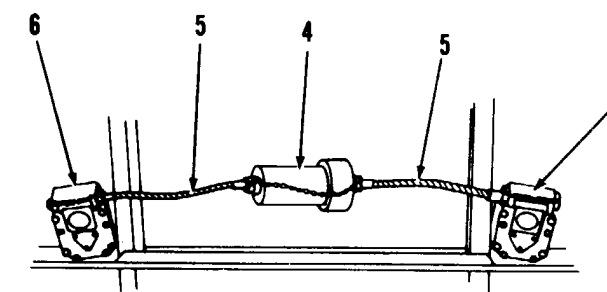

TASK	RESULT
1. Check windshield wiper arms (1) and wiper blades (2).	If either arm (1) is damaged, replace it. If either blade (2) is cracked, torn, or loose, replace it.
2. Check WINDSHIELD WIPERS switch (3).	If switch (3) is loose or damaged tighten or replace it as required.
3. Lower overhead panel.	
4. Check windshield wiper motor (4), shafts (5), and actuators (6).	If windshield wiper motor (4) is loose or damaged, tighten or replace it as required. If either shaft (5) is damaged, replace it. If either actuator (6) is loose or damaged, tighten or replace it as required.

FOLLOW-ON MAINTENANCE:

TM 55-1520-240-23:
Secure overhead panel

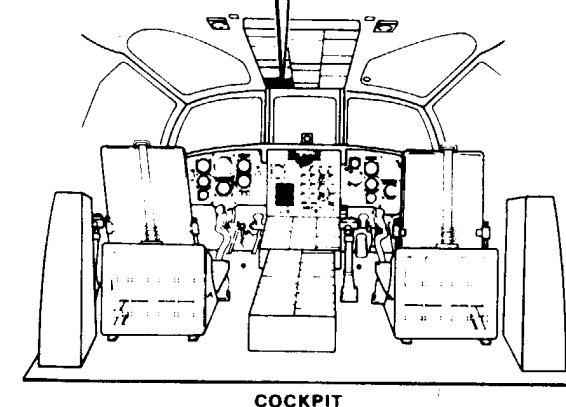

COCKPIT

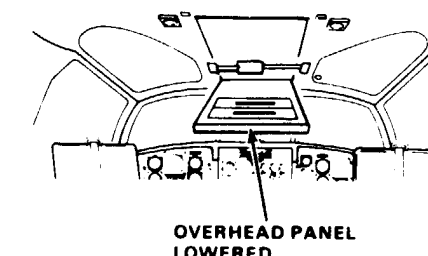

OVERHEAD PANEL
LOWERED.

12-4.3 WINDSHIELD WIPERS OPERATIONAL CHECK

INITIAL SETUP

Applicable Configurations:

All

Tools:

- Water Hose
- Stop Watch

Materials:

None

Personnel Required:

- 67U10 Medium Helicopter Repairer
- 68F20 Aircraft Electrician

References:

TM 55-1520-240-23

Equipment Condition:

TM 55-1520-240-23

Battery Connected

Electrical Power On

Hydraulic Power Off

Visual Check Of Windshleld Wipers Performed (Task 12-4.2)

Hose Connected To Water Supply

FOLLOW-ON MAINTENANCE:

TM 55-1520-240-23:

Electrical power off.

Battery disconnected.

Hose Disconnected

TASK	RESULT
1. Check that WSHLD WIPER circuit breaker (1) is closed.	If WSHLD WIPER clrcuit breaker (1) is open, close it. If it opens again, go to task 12-4.4.
CAUTION	
Do not operate windshield wipers on dry or dirty windshield. Windshield can become scratched.	
2. Spray pilot's and copilot's windshields with water. Continue spraying water until check is complete.	
3. Set WINDSHIELD WIPERS switch (2) to SLOW.	Both windshield wiper blades (3) shall move back and forth across pilot and copilot windshields approximately 80 times per minute without hitting windshield framing. If blades don't move or move too slow, go to task 12-4.5. If blades hit framing, adjust wiper arm (4) position.
4. Set WINDSHIELD WIPERS switch (2) to MED.	Both windshield wiper blades (3) shall move faster. If not, go to task 12-4.5.
5. Set WINDSHIELD WIPERS switch (2) to FAST.	Both wiper blades (3) shall move back and forth across windshields approximately 138 times per minute. If not, go to task 12-4.5. If excessive noise comes from direction of overhead panel, go to task 12-4.6
6. Set WINDSHIELD WIPERS switch (2) to OFF.	Both wiper blades (3) shall immediately stop. If not, replace WINDSHIELD WIPERS switch (2).
7. Set and hold WINDSHIELD WIPERS switch (2) to PARK.	Each wiper blade (3) shall move to inboard edge of it's windshield (park position). If not go to task 12-4.7.
8. Release WINDSHIELD WIPERS switch (2).	WINDSHIELD WIPERS switch (2) shall return to OFF position. If not, replace WINDSHIELD WIPERS switch.

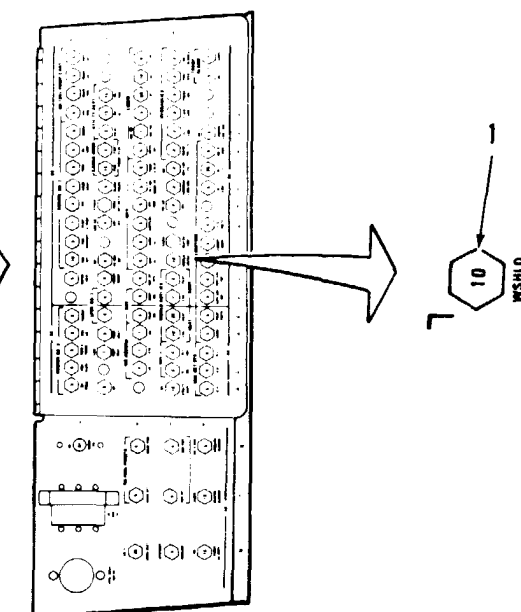
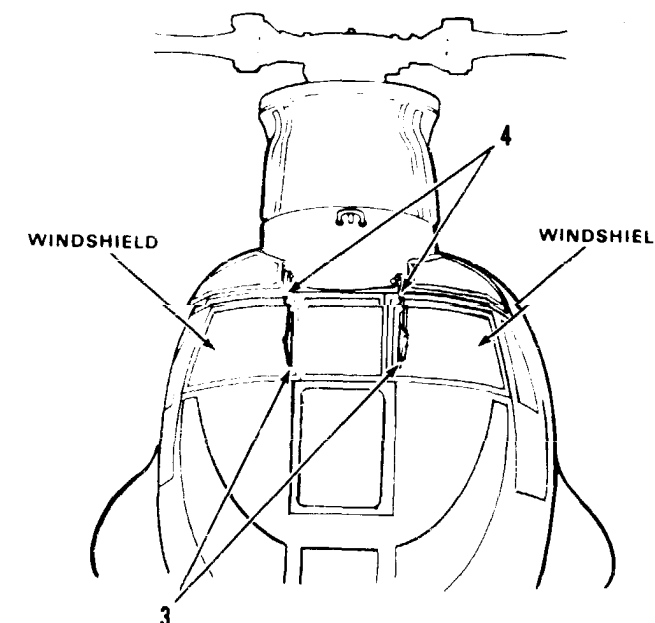
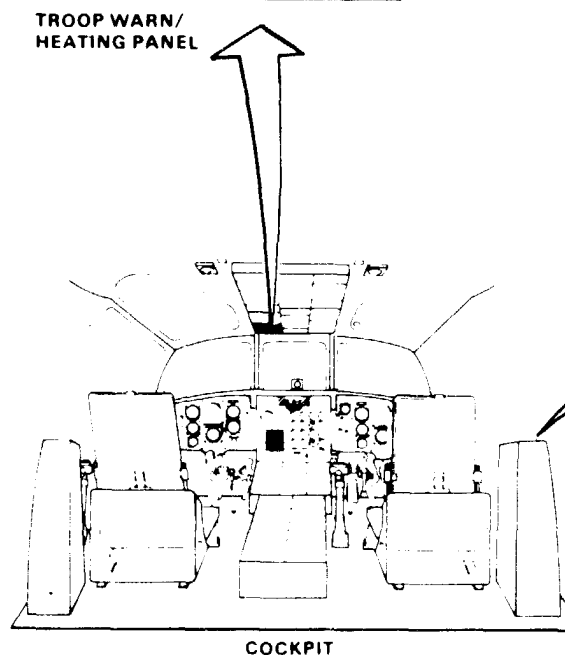
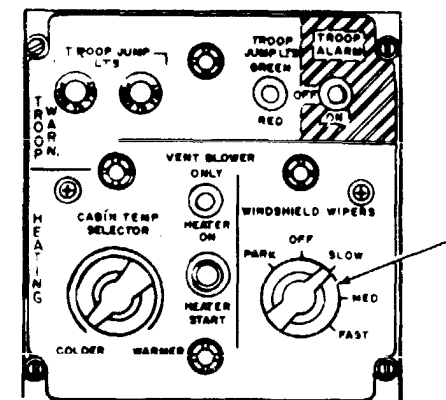

NO 2 POWER DISTRIBUTION PANEL (PDP) VIEW LOOKING AFT

12-4.4 WSHLD WIPER CIRCUIT BREAKER WILL NOT STAY CLOSED

12-4.4

FAULT ISOLATION PROCEDURE

INITIAL SETUP

Applicable Configurations:
All

Tools:
Electrical Repairer's Tool Kit,
NSN 5180-00-323-4915
Multimeter

Materials:
None

Personnel Required:
68F20 Aircraft Electrician

References:
TM 55-1520-240-23

Equipment Condition:
TM 55-1520-240-23:
Battery Disconnected
Electrical Power Off
Hydraulic Power Off

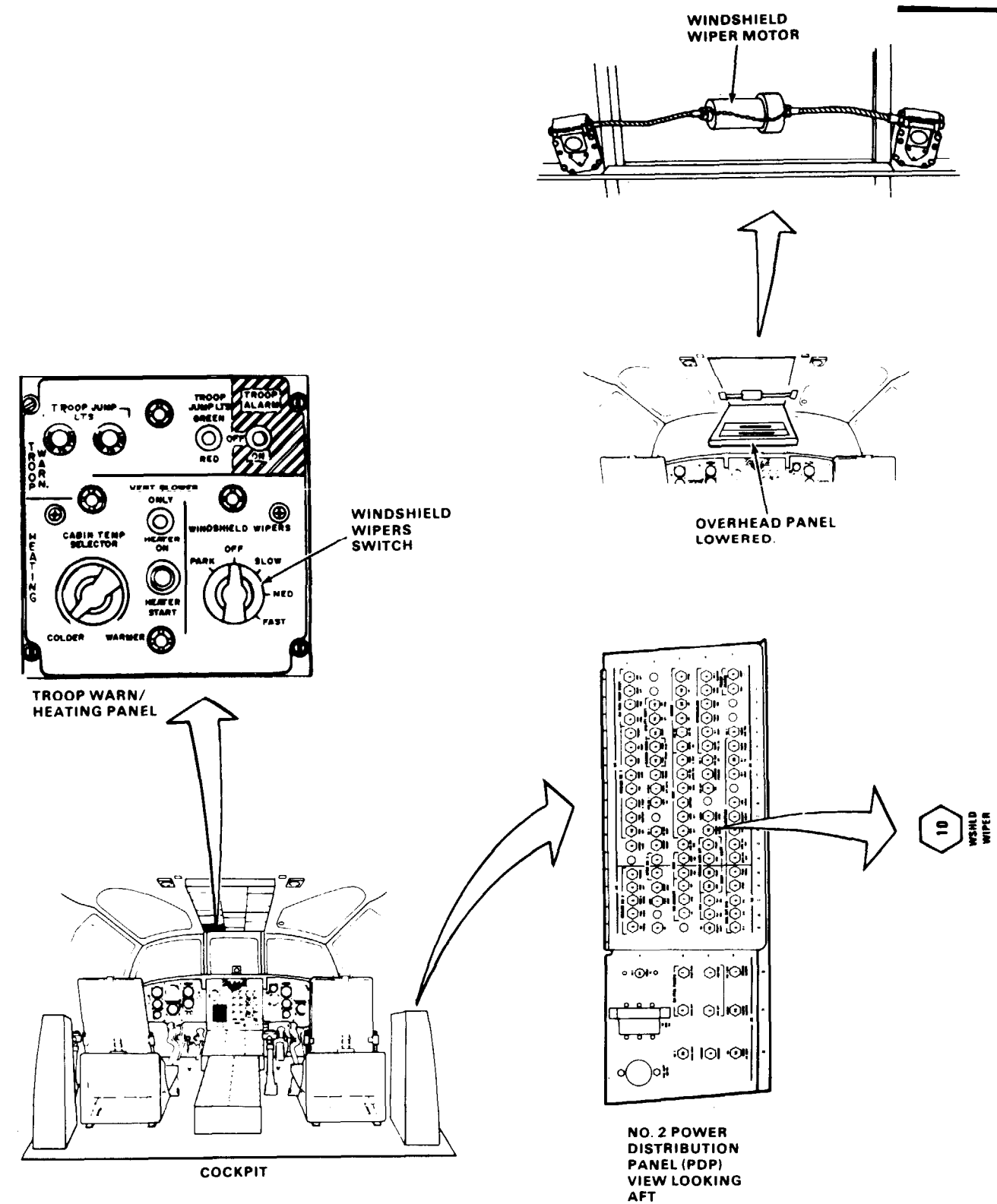
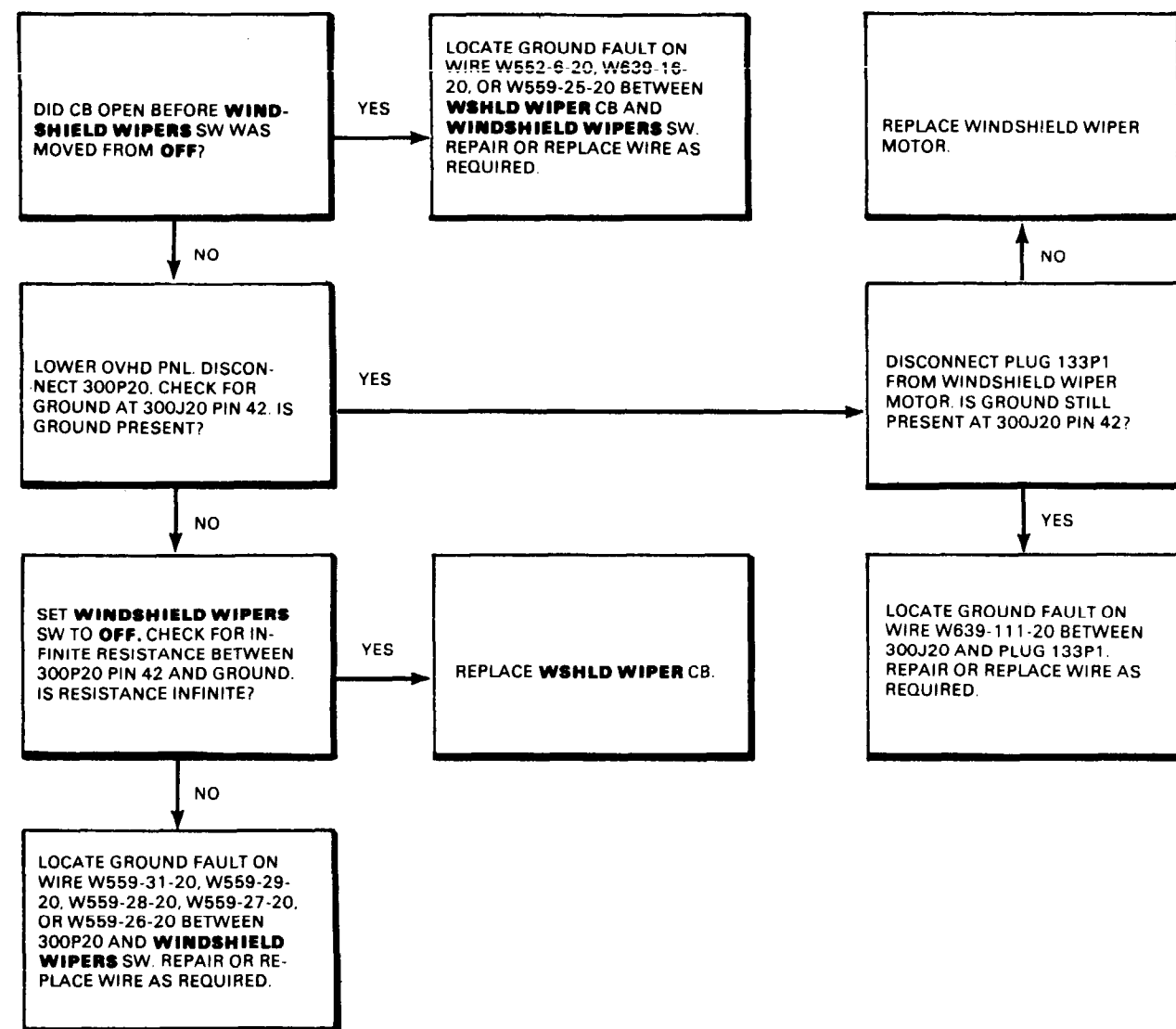

45x54

DI45-4928-SPA

END OF TASK

12-75

12-4.5 WINDSHIELD WIPER OR WIPERS DO NOT OPERATE AT ONE SWITCH POSITION OR ANY SWITCH POSITION

FAULT ISOLATION PROCEDURE

INITIAL SETUP

Applicable Configurations:
All

Tools:
Electrical Repairer's Tool Kit,
NSN 5180-00-323-4915
Multimeter

Materials:
None

Personnel Required:
68F20 Aircraft Electrician

References:
TM 55-1520-240-23

Equipment Condition:
TM 55-1520-240-23
Battery Connected
Electrical Power On
Hydraulic Power Off
Windshields Clean And Wet

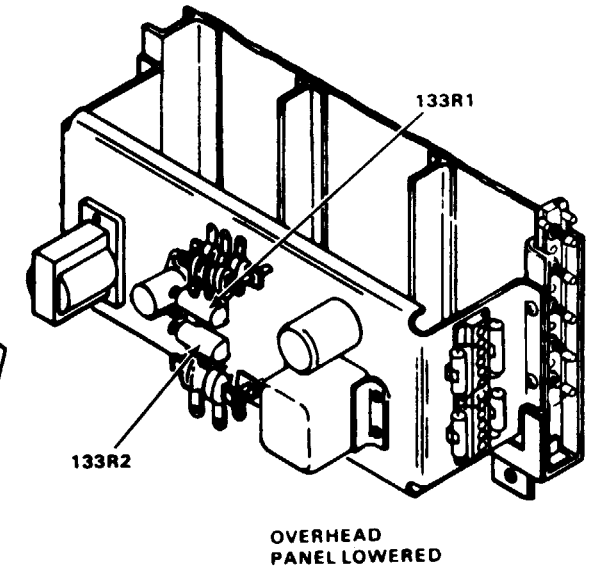
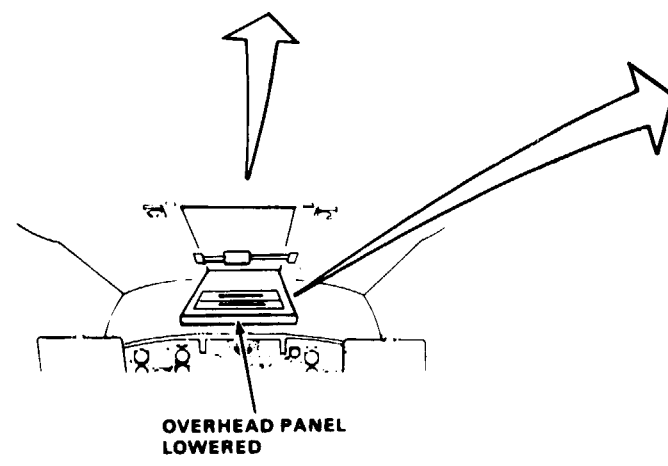
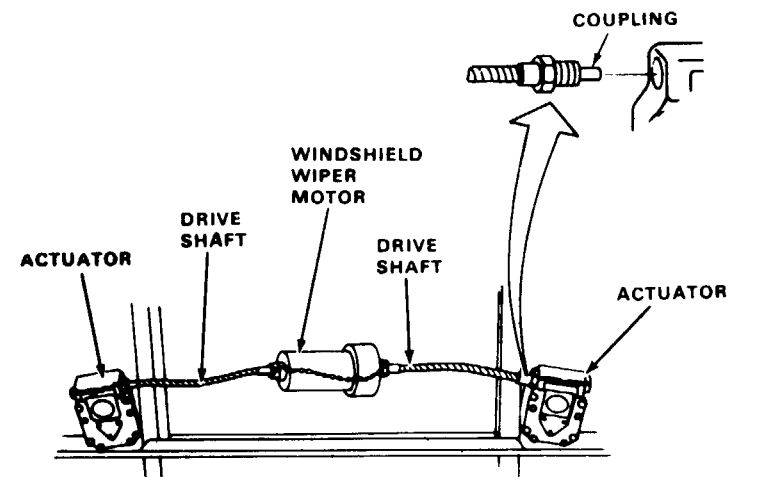
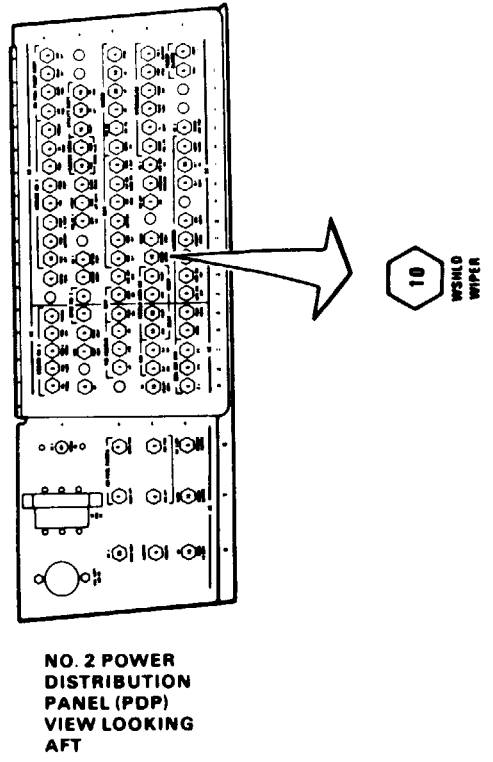
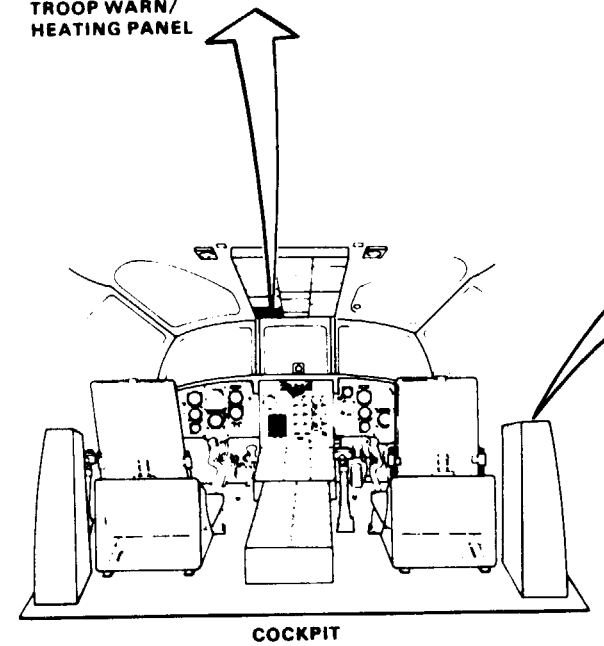
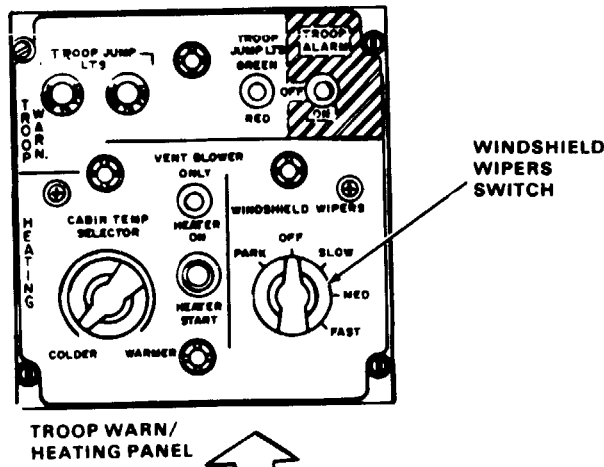
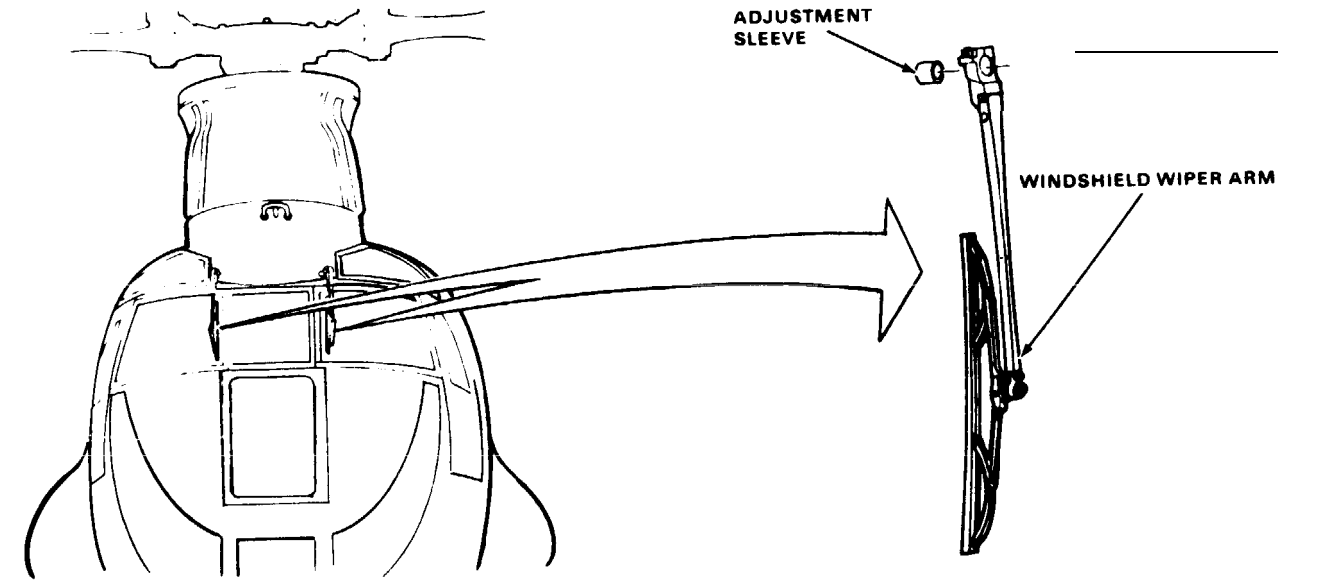

12-4.5 WINDSHIELD WIPER OR WIPERS DO NOT OPERATE AT ONE SWITCH POSITION OR AT ANY SWITCH POSITION (Continued)

12-4.5

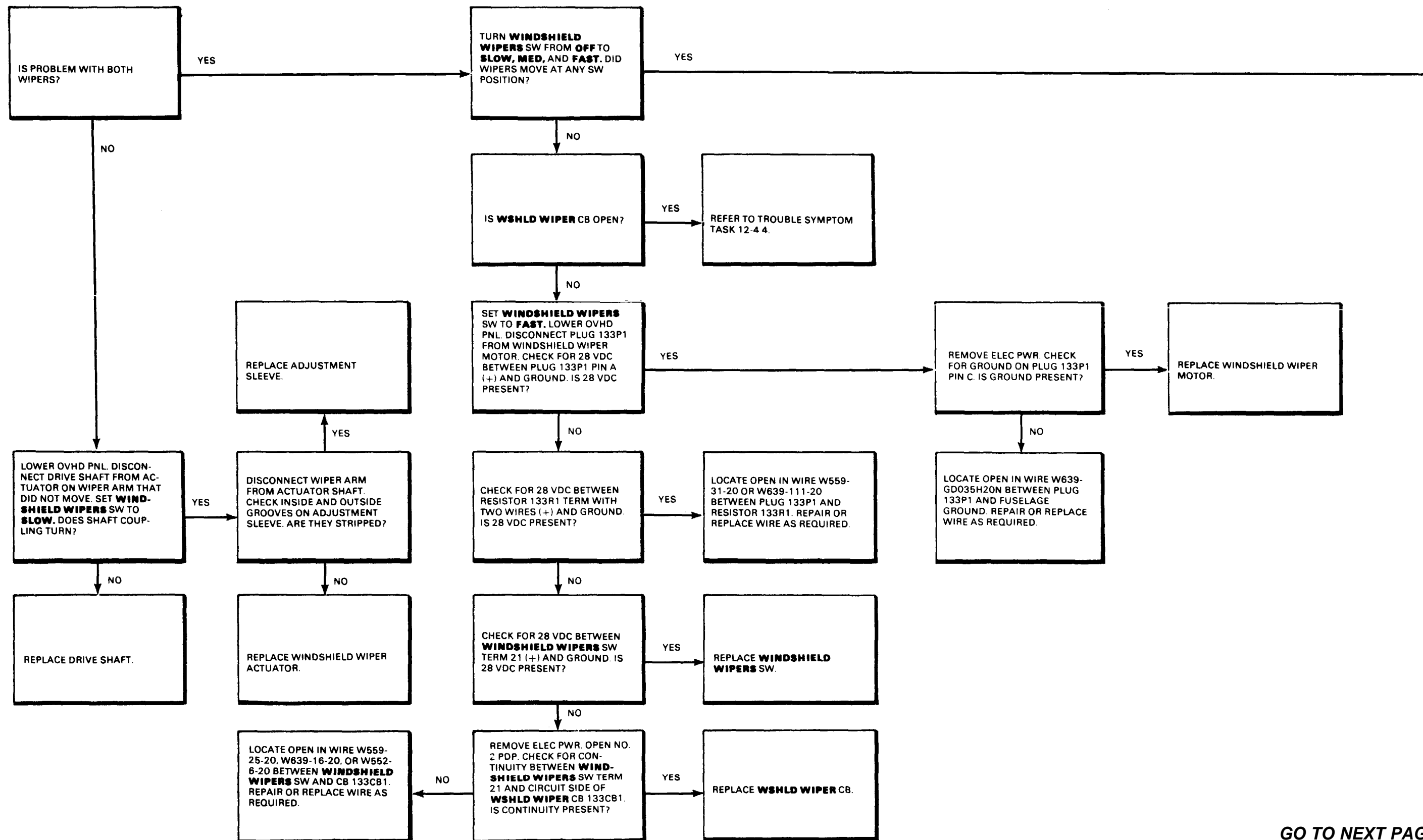

GO TO NEXT PAGE

12-77

12-4.5 WINDSHIELD WIPER OR WIPERS DO NOT OPERATE AT ONE SWITCH POSITION OR AT ANY SWITCH POSITION (Continued)

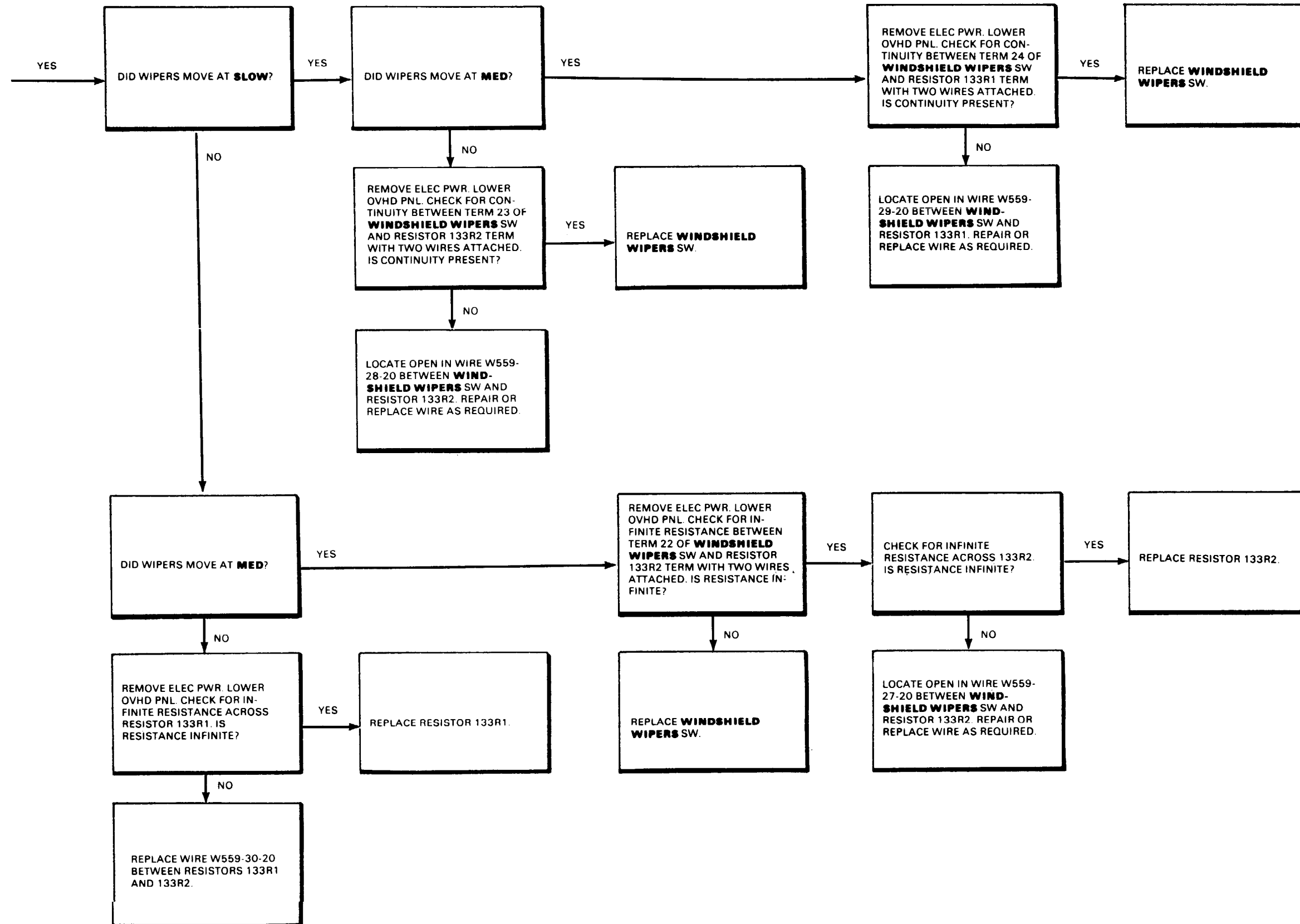

12-4.5 WINDSHIELD WIPER OR WIPERS DO NOT OPERATE AT ONE SWITCH POSITION OR AT ANY SWITCH POSITION (Continued)

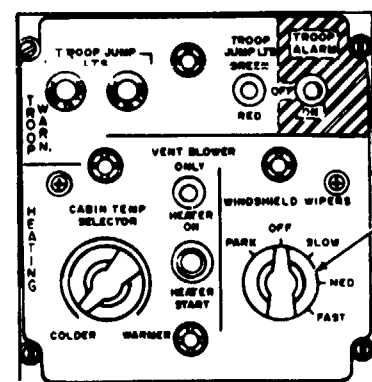

WINDSHIELD WIPERS SWITCH

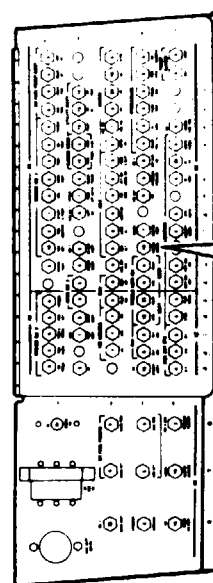
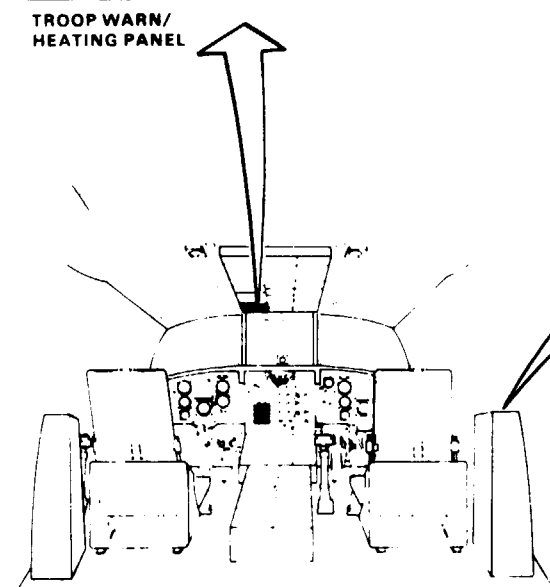

10 WINDSHIELD WIPER

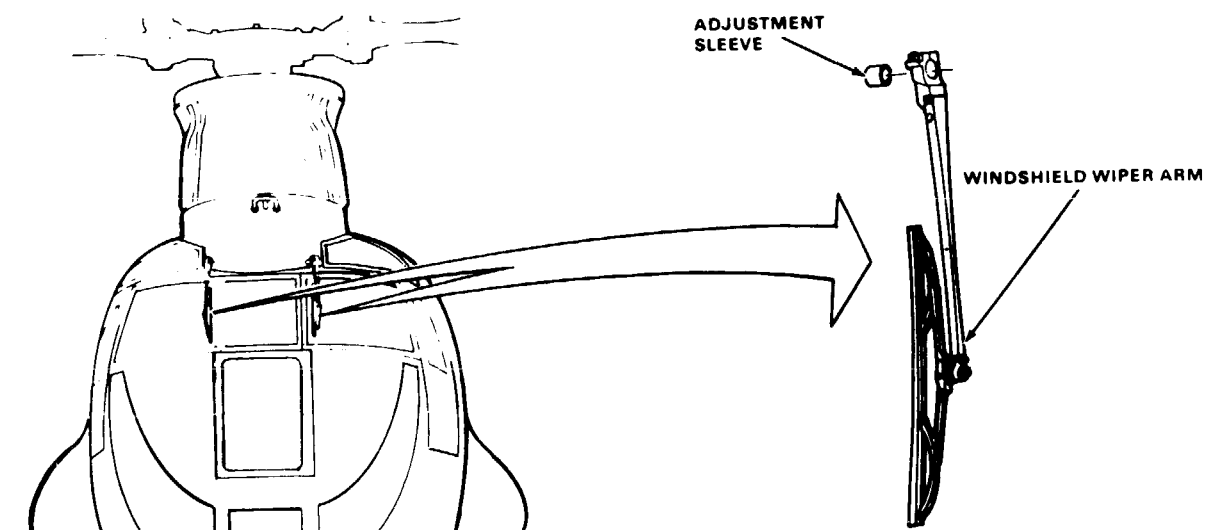
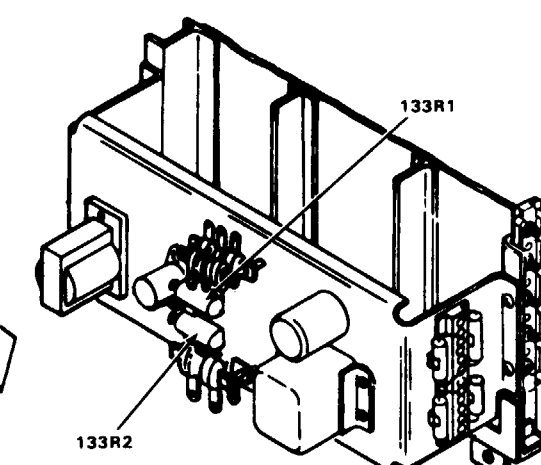
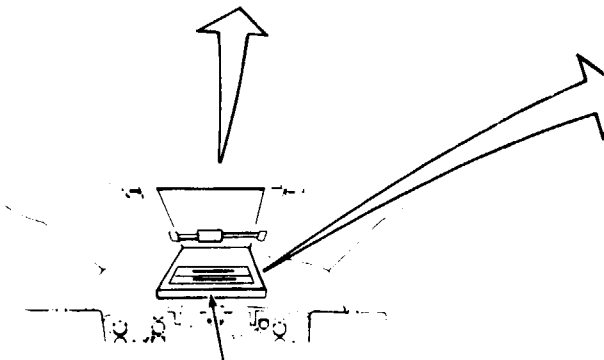
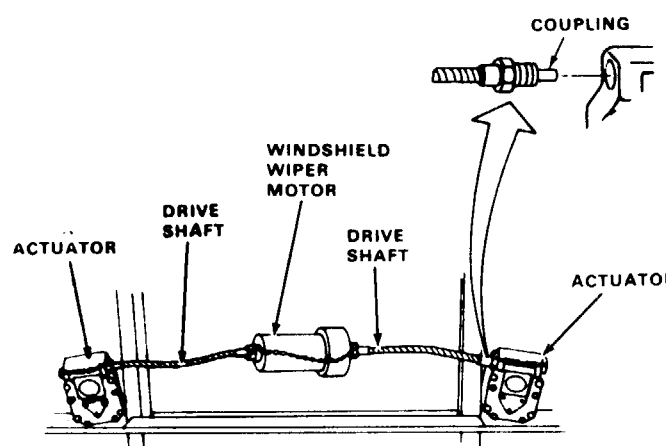

FAULT ISOLATION PROCEDURE

INITIAL SETUP

Applicable Configurations:
All

Tools:
Aircraft Mechanic's Tool Kit,
NSN 5180-00-323-4692

Materials:
None

Personnel Required:
67U20 Medium Helicopter Repairer

References:
TM 55-1520-240-23

Equipment Condition:
TM 55-1520-240-23:

Battery Connected
Electrical Power On
Hydraulic Power Off
Overhead Panel Lowered
Windshields Clean And Wet

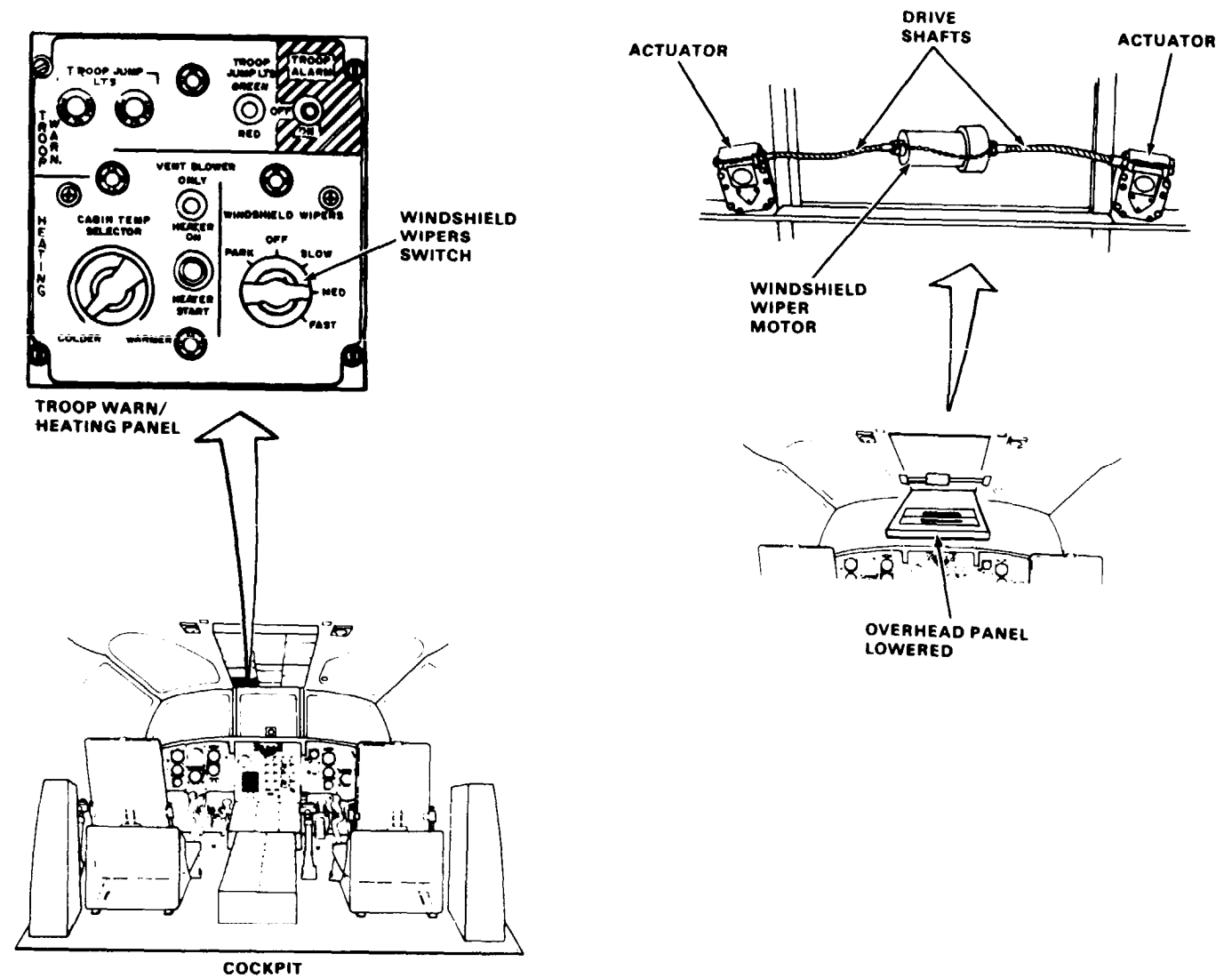
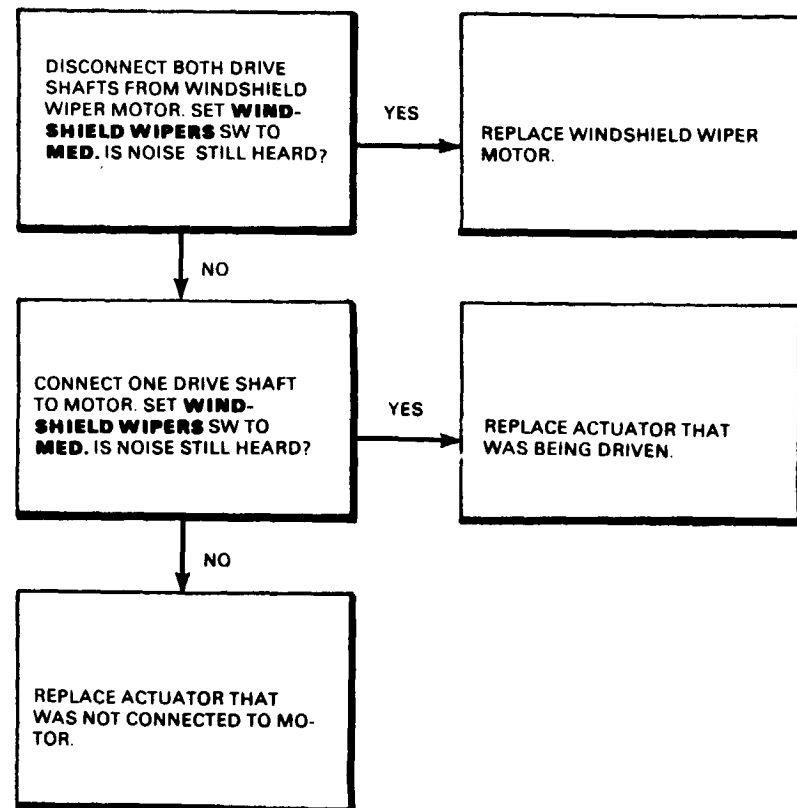

45x54

DI45-4930-SPA

END OF TASK

FAULT ISOLATION PROCEDURE

INITIAL SETUP

Applicable Configurations:

Tools:

- Electrical Repairer's Tool Kit,
NSN 5180-00-323-4915
- Multimeter

Materials:

None

Personnel Required:

Aircraft Electrician

References:

TM 55-1520-240-23

Equipment Condition:

TM 55-1520-240-23:

- Battery Connected
- Electrical Power On
- Hydraulic Power Off
- Overhead Panel Lowered

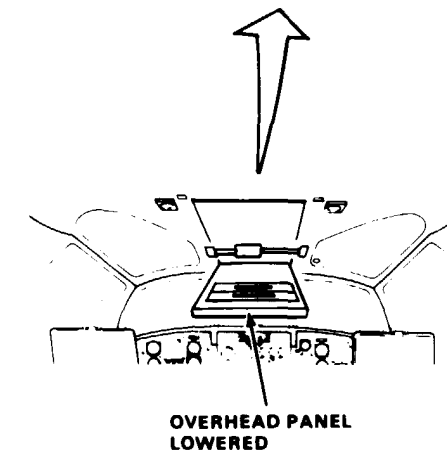
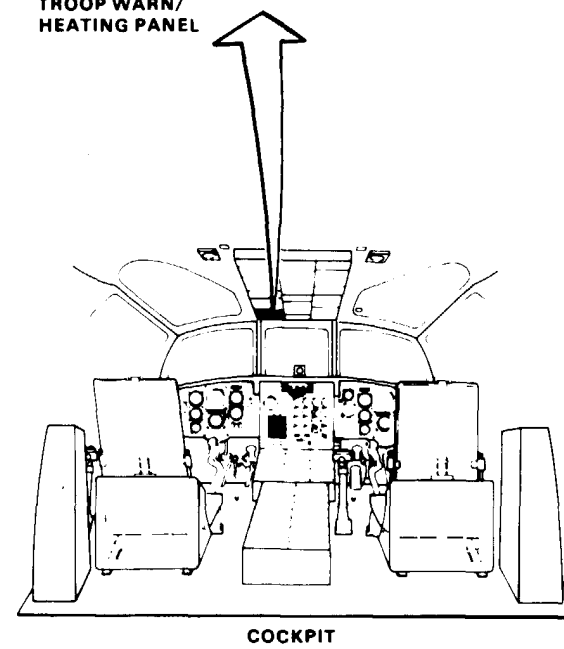
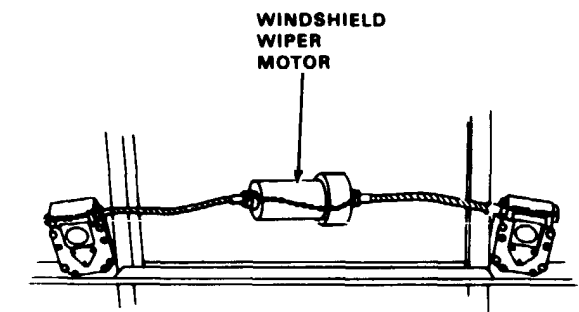
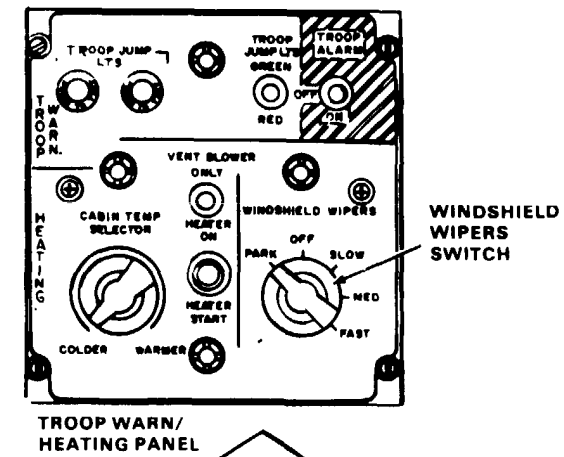

12-4.7 WINDSHIELD WIPERS DO NOT RETURN TO PARK POSITION
(Continued)

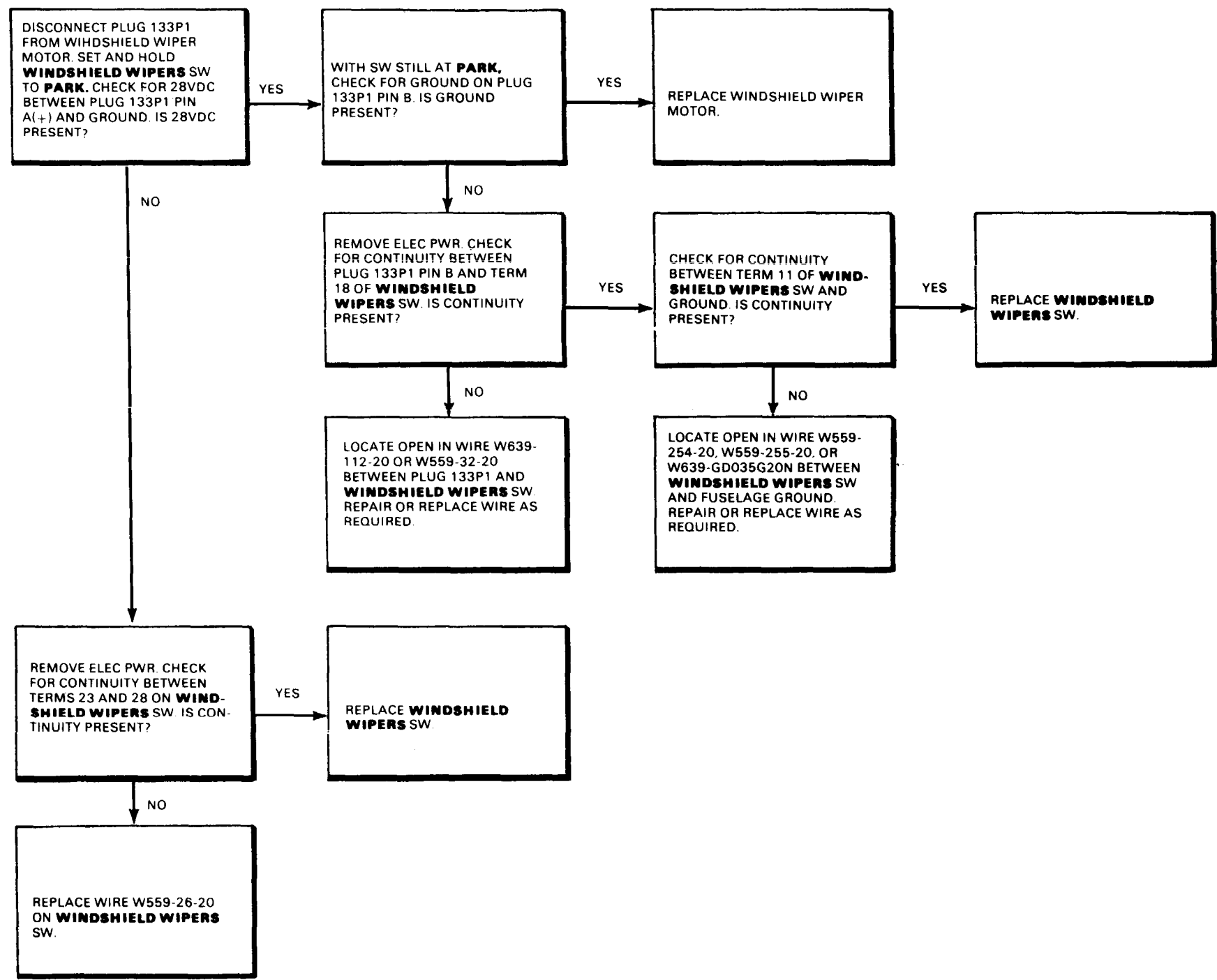

CHAPTER 13

ENVIRONMENTAL CONTROL SYSTEM
TROUBLESHOOTING

**CHAPTER 13
ENVIRONMENTAL CONTROL SYSTEM TROUBLESHOOTING
CHAPTER OVERVIEW**

Chapter 13 contains procedures for Environmental Control System Troubleshooting. Each environmental control system failure symptom is listed below. Included in this Chapter are locations and views of all electrical connectors, receptacles, relays, and ground connections for the Environmental Control System. Refer to TM 55-1520-240-23 for required Environmental Control System maintenance procedures.

SYSTEM	PARA
HEATING AND VENTILATION	13-1

FAILURE SYMPTOM LIST

HEATING AND VENTILATION

SYMPTOM	TASK	SYMPTOM	TASK
AIR FLOW NOT FELT AT CABIN VENTS	13-1.4	HEATER DOES NOT PROVIDE WARM AIR	13-1.4
AIR FLOW NOT FELT AT JETTISONABLE DOOR DEFROSTER DUCTS OR NOSE BUBBLE VENTS	13-1.4	HEATER FAN CANNOT BE HEARD RUNNING	13-1.4
AIR FLOW NOT FELT AT PILOT OR COPILOT AIR OUTLET	13-1.4	HEATER FAN CANNOT BE HEARD RUNNING AFTER HEATER START SWITCH PRESSED AND RELEASED	13-1.4
CABIN HEATER BLOWER CIRCUIT BREAKER WILL NOT STAY CLOSED	13-1.4	HEATER FAN STOPS RUNNING IMMEDIATELY AFTER HEATER FAN SWITCH SET TO OFF	13-1.4
CABIN HEATER CONT CIRCUIT BREAKER WILL NOT STAY CLOSED	13-1.4	HEATER HOT (WITHOUT 74) HTR HOT (WITH 74) LIGHT COMES ON	13-1.4
		SYSTEM DOES NOT RESPOND TO CHANGES IN CABIN TEMP SELECTOR SETTING	13-1.4

ENVIRONMENTAL SYSTEM ELECTRICAL COMPONENT LOCATION AND CONFIGURATION LIST

REF DESIG	PART NUMBER	TYPE	MATE WITH/LOCATION	STATION LOCATION			REF DESIG	PART NUMBER	TYPE	MATE WITH/LOCATION	STATION LOCATION		
				FS	WL	BL					FS	WL	BL
GD007		150	HEATER COMPARTMENT	95	5	45R	174P6	MS3476W14-19P	21	AIRCRAFT SKIN - TANK SIDE	374	-10	50R
GD047		150	NO. 2 PDP SIDEWALL				232P1	MS3476W22-55S	161	CONSOLE - CTR INST PNL - MASTER CAUTION PANEL (WITH 74)			
GD104		151	HEATER COMPARTMENT	95	30	50R							
GD107		151	HEATER RELAY BOX - INTERNAL	95	30	25R	232P2	MS3476W16-26S	24	CONSOLE - CTR INST PNL - MASTER CAUTION PANEL (WITHOUT 74)			
GD108		151	HEATER COMPARTMENT	95	5	48R							
GD126		151	RH CABIN	330	30	50L	300J4	M83723-74A2461N	43	NO. 1 PDP			
GD160		151	LH CABIN	380	-10	50R	300P4	M83723-75A2461N	43	NO. 1 PDP			
TB17			WALKWAY- UNDERFLOOR	105	-30	18R	300J5	M83723-74A2041N	40	NO. 2 PDP			
082K1		77	NO. 2 PDP				300P5	M83723-75A2041N	40	NO. 2 PDP			
082K2		68	HEATER RELAY BOX INTERNAL	95	30	25R	300J15	M83723-74A24617	43	CONSOLE- UNDERFLOOR	85	-20	5R
082K3		68	HEATER RELAY BOX INTERNAL	95	30	25R	300P15	M83723-75A24617	43	CONSOLE- UNDERFLOOR	85	-20	5R
082K4		65	HEATER RELAY BOX INTERNAL	95	30	25R	300J18	M83723-73A2041N	40	OVERHEAD PANEL - COCKPIT			
082K5		66	HEATER RELAY BOX INTERNAL	95	30	25R	300P18	M83723-76A2041N	40	OVERHEAD PANEL -COCKPIT			
082P1	MS3456W10SL-4S	46	RH AFT POD INTRTANK BAY	374	-5	52R	300J20	M83723-74A2461N	43	OVERHEAD PANEL -COCKPIT			
082P2	MS3456W14S-2S	48	CABIN THERMOSTAT	350	20	50L	300P20	M83723-75A2461N	43	OVERHEAD PANEL -COCKPIT			
082P3	MS3456W14S-6S	50	HEATER TEMP CONT	95	30	25R	300J56	M83723-73A2255N	42	HEATER COMPARTMENT OVHD	105	40	30R
082P4	MS3456W14S-5S	49	HEATER FUEL CONT	115	20	45R	300P56	M83723-76A2255N	42	HEATER COMPARTMENT OVHD	105	40	30R
082P5	MS3456W10SL-4S	46	HEATER IGN ASSY	100	-10	45R	300J68	M83723-73A22556	42	HEATER COMPARTMENT OVHD	105	40	25R
082P6	MS3456W16-11S	52	HEATER DIFF PRES SW	95	5	20R	300P68	M83723-76A22556	42	HEATER COMPARTMENT OVHD	105	40	25R
082J7	MS3470W14-19P	21	HEATER RELAY BOX-- RECPT	95	30	25R							
082P7	MS3476W14-19S	21	HEATER RELAY BOX	105	30	40R							
082P8	MS3456W18-11S		HEATER FAN	105	30	40R							
174J6	MS3474W14-19S	21	AIRCRAFT SKIN - INSIDE	374	-10	50R							

ENVIRONMENTAL SYSTEM ELECTRICAL COMPONENT LOCATION AND CONFIGURATION LIST (Continued)

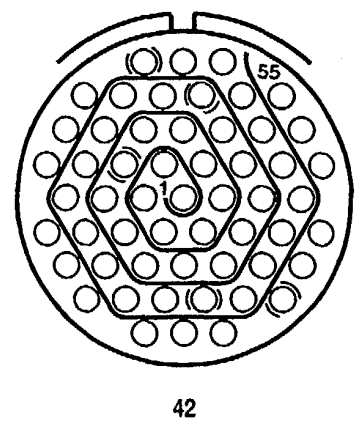
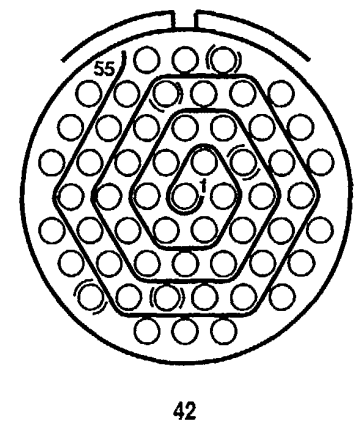
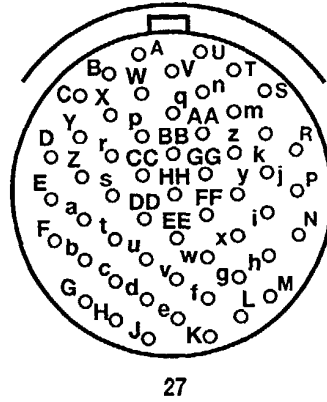
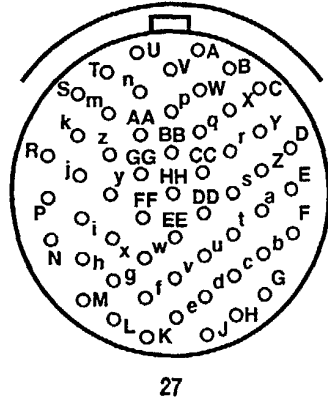
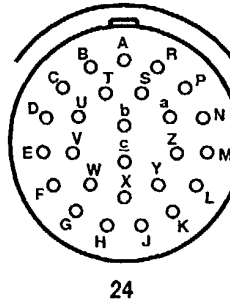
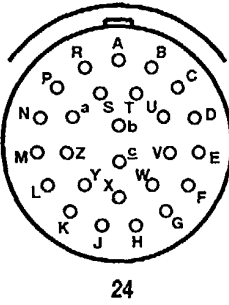
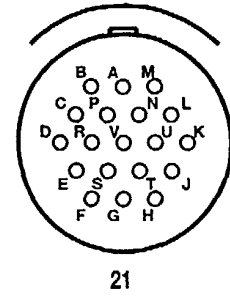
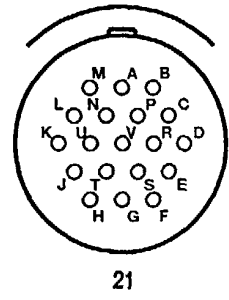

RECEPTACLE

PLUG

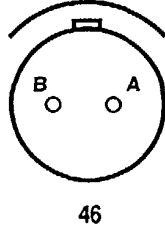
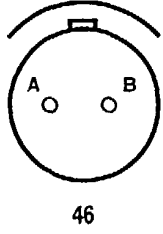
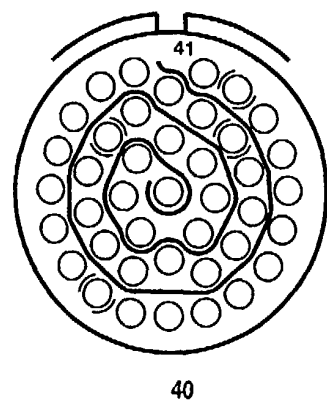
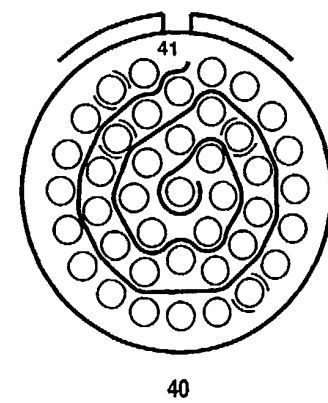
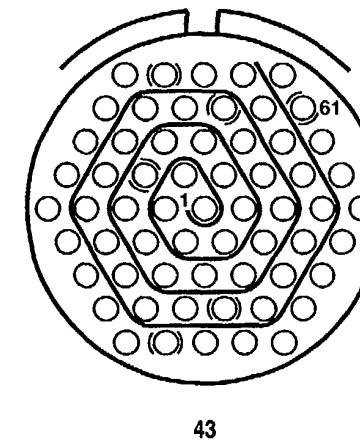
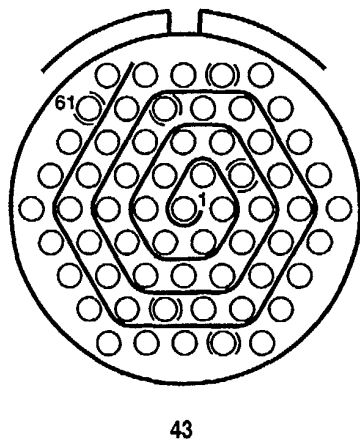

ENVIRONMENTAL SYSTEM ELECTRICAL COMPONENT LOCATION AND CONFIGURATION LIST (Continued)

RECEPTACLE

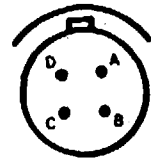

48



49



50

PLUG

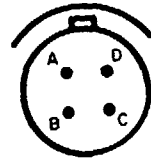

48

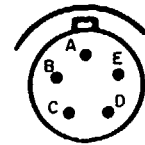

49

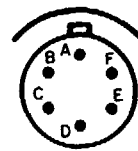

50

RECEPTACLE

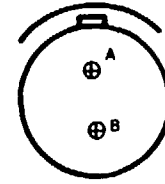

52

RELAY

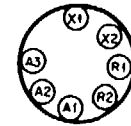

105

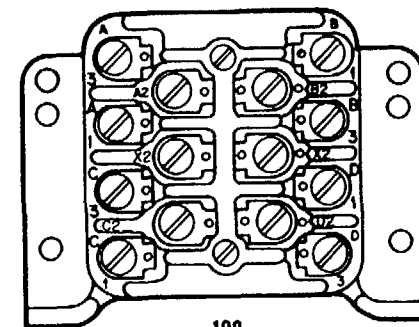

108

PLUG

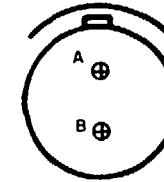

52

RELAY

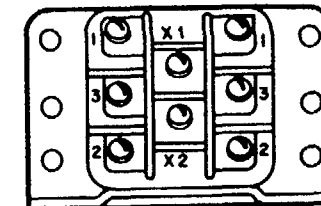

106

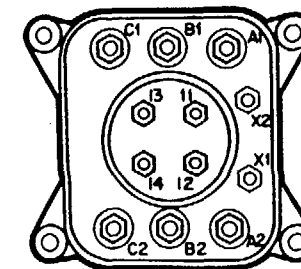

117

ENVIRONMENTAL CONTROL SYSTEM ELECTRICAL COMPONENT
LOCATION AND CONFIGURATION LIST (Continued)

GND MODULE

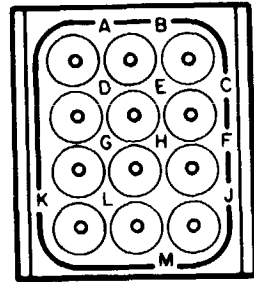

150

GND STUD



151

13-1 HEATING AND VENTILATING SYSTEM

13-1.1 HEATING AND VENTILATING SYSTEM SCHEMATIC

- NOTES:
1. ONLY LEFT SIDE OF SYSTEM AIR OUTLETS SHOWN.
 2. POINTS ARE CLOSED BY MERCURY HEATED TO 93°F (34°C) THEREBY DEENERGIZING TEMP CONTROL RELAY
 3. LEGEND:

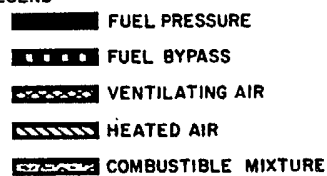

4. HEATER FAN SWITCH CONTACTS CLOSED AS FOLLOWS:
- | SWITCH POSITION | CONTACTS CLOSED |
|------------------|-----------------|
| VENT BLOWER ONLY | 1-2, 4-5 |
| HEATER ON | 2-3, 5-6. |

5. [Symbol] INDICATES EQUIPMENT MARKING.
6. [Symbol] WITHOUT [Symbol]
7. [Symbol] WITH [Symbol]

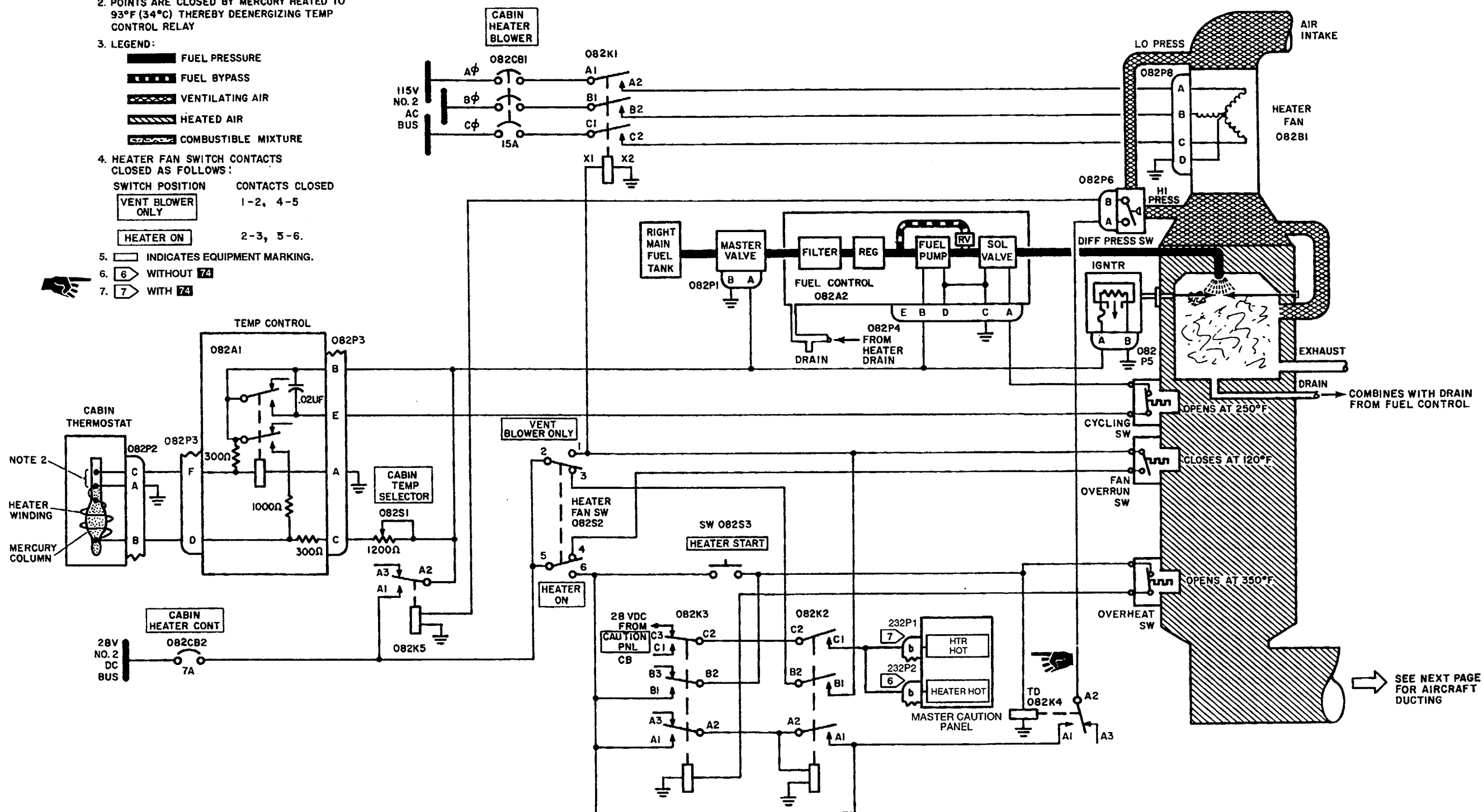

SEE NEXT PAGE FOR AIRCRAFT DUCTING

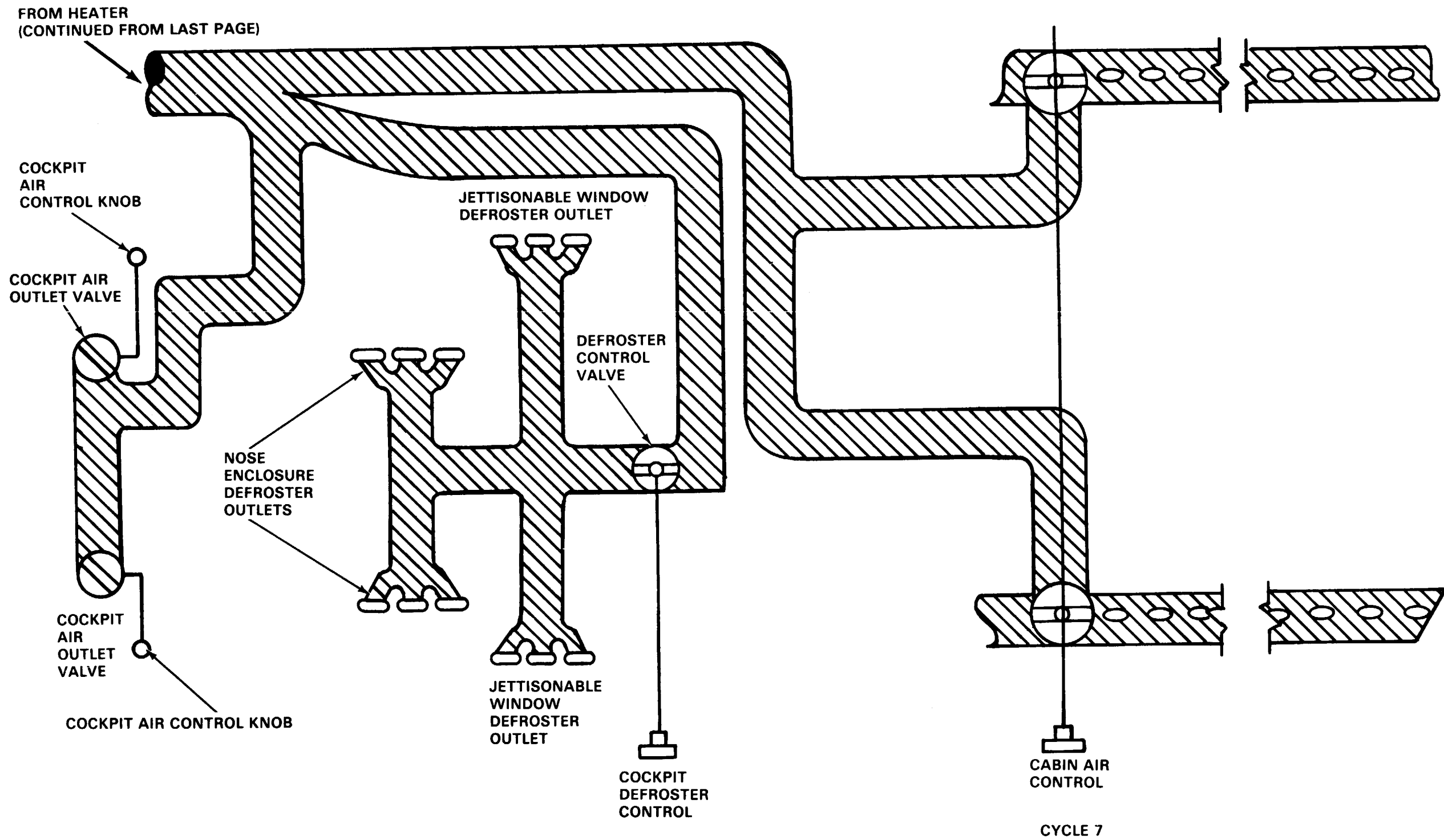

13-1.2 HEATING AND VENTILATING SYSTEM WIRING DIAGRAM

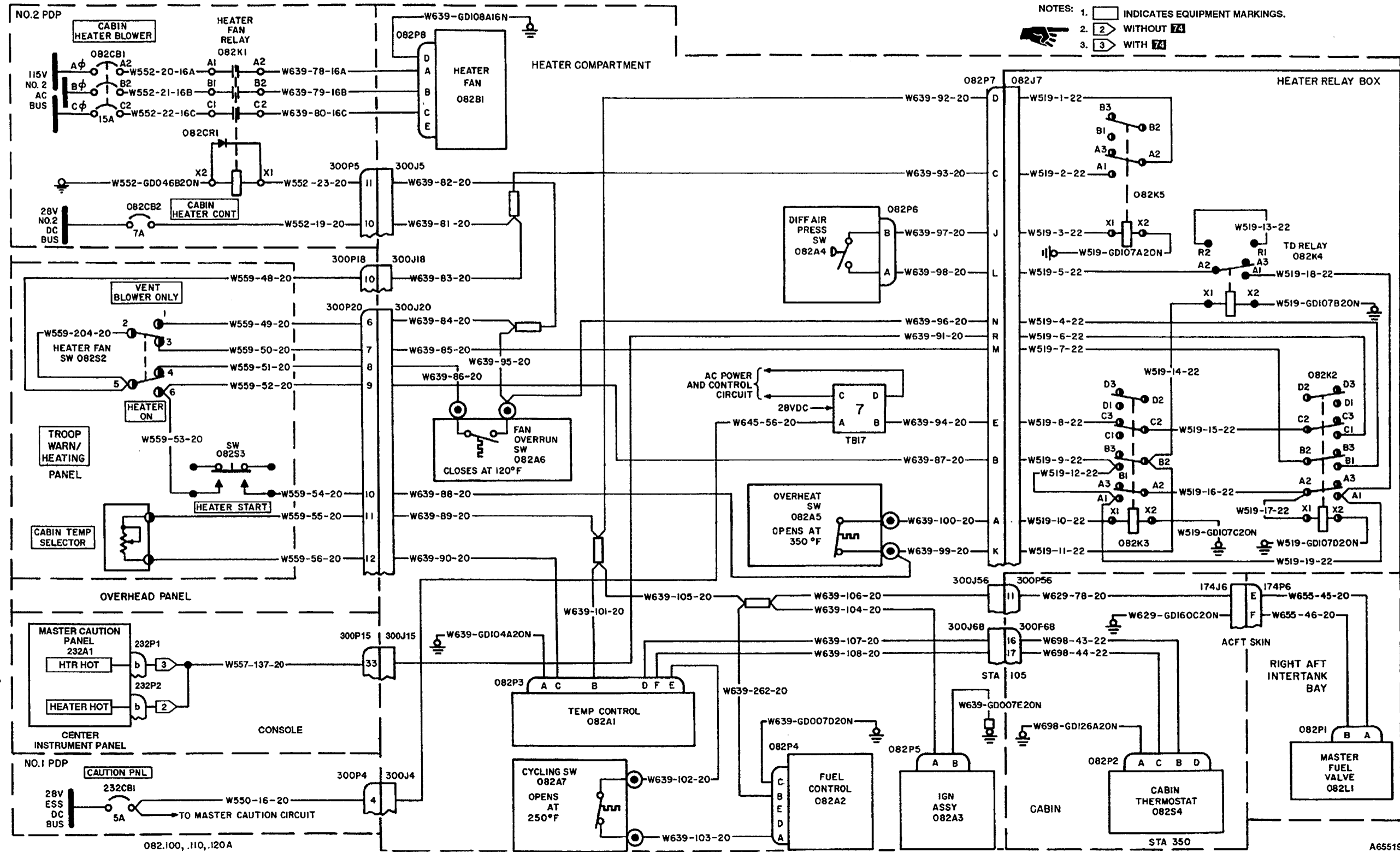

13-1.3 HEATING AND VENTILATING SYSTEM VISUAL CHECK

INITIAL SETUP

Applicable Configurations:

All

Tools:

Aircraft Mechanic's Tool Kit,
NSN 5180-00-323-4692

Materials:

None

Personnel Required:

67U10 Medium Helicopter Repairer

References:

TM 55-1520-240-23

Equipment Condition:

TM 55-1520-240-23

Battery Disconnected
Electrical Power Off
Hydraulic Power Off
Heater Compartment Acoustic
Blanket Removed

TASK	RESULT
1. Check air pressure switch (1).	If switch (1) is loose or damaged, tighten or replace it as required. If tubes, wiring, or electrical connector to switch are damaged, repair or replace them as required.
2. Check heater fan (2).	If fan (2) is loose or damaged, tighten or replace it as required. If wiring or electrical connector to fan is damaged, repair or replace it as required.
3. Check heater control relay box (3).	If box (3) is loose or damaged, tighten or replace it as required. If wiring or electrical connector to box is damaged, repair or replace it as required.
4. Check temperature controller (4).	If controller (4) is loose or damaged, tighten or replace it as required. If wiring or electrical connector to controller is damaged, repair or replace it as required.
5. Check air inlet duct (5).	If duct (5) is loose or torn, tighten or replace it as required.
6. Check heater fuel control (6).	If control (6) is loose or damaged, tighten or replace it as required. If fuel hoses, wiring or electrical connector to control is damaged, repair or replace it as required.
7. Check heater ignition unit (7).	If ignition unit (7) is loose or damaged, tighten or replace it as required. If wiring, electrical connector, or shielded lead (8) to ignition unit is damaged, repair or replace it as required.
8. Check boiler (9).	If heater (9) is damaged, replace it.
9. Check exhaust shroud (10).	If shroud (10) is damaged, repair or replace it as required.
10. Check three temperature switches (11).	If any switch (1) is loose or damaged, tighten or replace it as required. If wiring to any switch is damaged, repair or replace it as required.

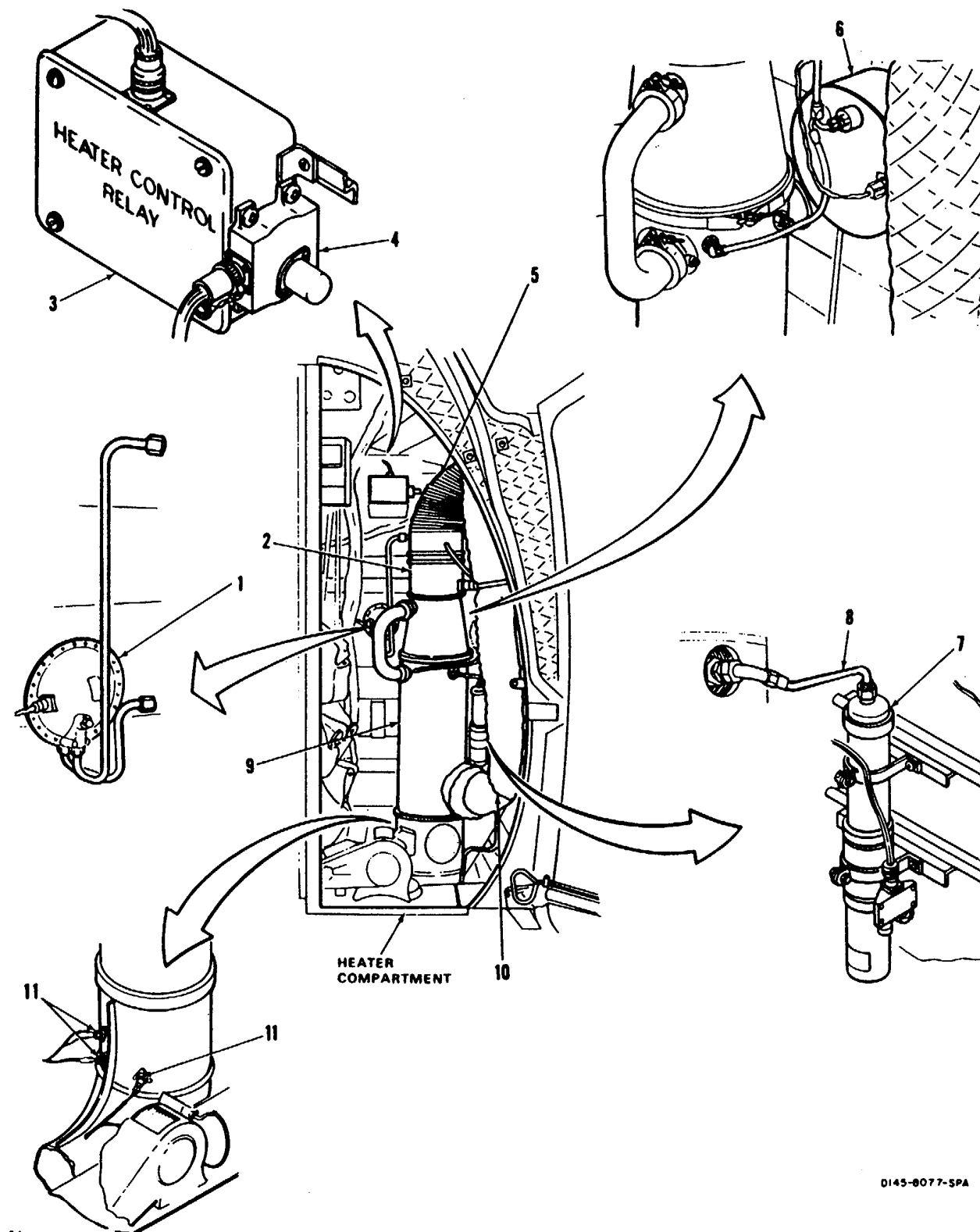

0145-8077-5PA

45-54

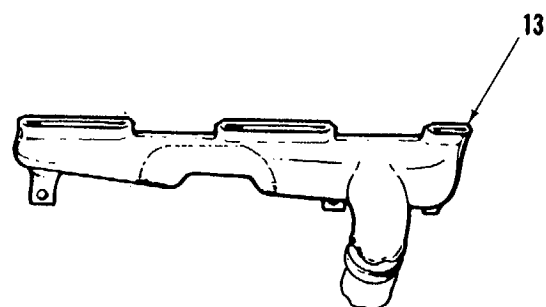
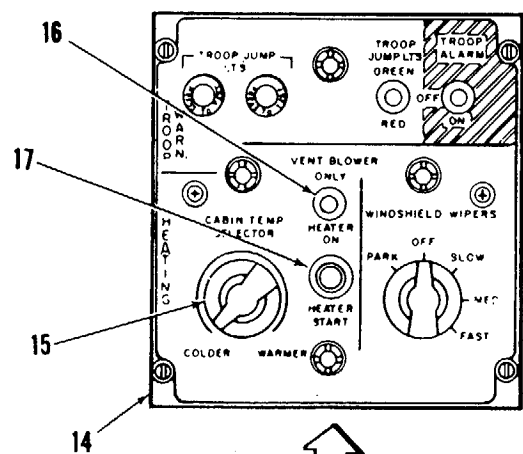
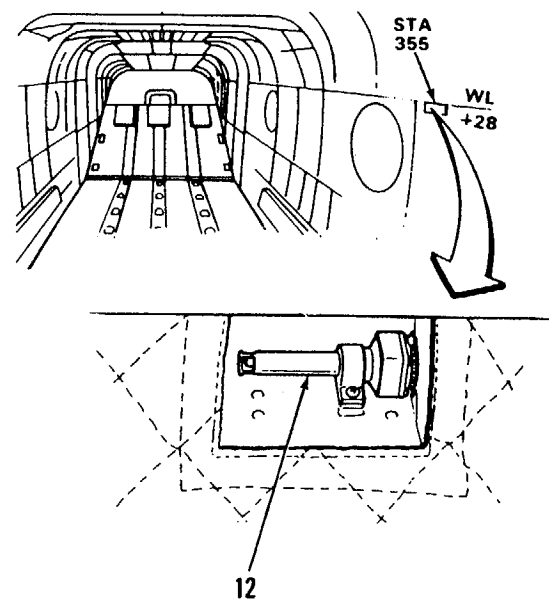

VIEW LOOKING DOWN AND OUTBOARD. PILOT'S JETTISONABLE DOOR DEFROSTER DUCT SHOWN, COPILOT'S OPPOSITE

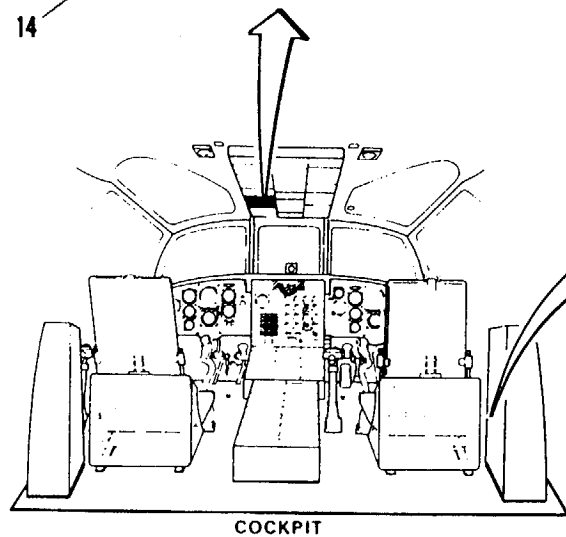

TASK	RESULT
11. Check cabin thermostat (12).	If thermostat (12) is loose or damaged, tighten or replace it as required.
12. Check pilot's jettisonable door defroster (13).	If defroster (13) is damaged, repair or replace it as required.
13. Check copilot's jettisonable door defroster (13).	If defroster (13) is damaged, repair or replace it as required.
14. Check TROOP WARN/HEATING panel (14).	If knob (15) is loose, tighten or replace it as required. If switch (16 or 17) is damaged, replace it.

FOLLOW-ON MAINTENANCE:
 TM 55-1520-240-23
 Install heater compartment acoustic blanket.

13-1.4 HEATING AND VENTILATING SYSTEM OPERATIONAL CHECK

13-1.4

INITIAL SETUP

Applicable Configurations:

All

Tools:

Stopwatch

Materials

None

Personnel Required:

Medium Helicopter Repairer

References:

TM 55-1520-240-23

Equipment Condition:

- TM 55-1520-240-23:
- Battery Connected
- Electrical Power On
- Hydraulic Power Off
- Heater Air Inlet Protective Shield Removed
- Heater Exhaust Outlet Protective Shield Removed
- Visual Check of Heating and Ventilating System Performed

TASK

RESULT

13. **Press and release HEATER START switch (15).**

NOTE

Heater will not operate if cabin thermostat senses a temperature of **34°C (93°F) or greater.**

Heater fan shall be heard. After about 10 seconds, combustion shall occur and warm air shall flow from all vents and ducts. If heater fan can not be heard, go to Task 13-1.11. If heater fan is running but warm air is not flowing from ducts or vents, go to Task 13-1.12. If HEATER HOT (Without 74) HTR HOT (With 74) capsule (16) comes on, go to Task 13-1.13.

14. **Turn CABIN TEMP SELECTOR (14) to COLDER position.**

Cooler air shall be felt flowing from ducts and vents. If air doesn't get cooler or air gets hotter, go to Task 13-1.14.

15. **Set heater fan switch (8) to off (center).**

Heater fan shall run until heater cools down. If fan is not running after heater is turned off, go to Task 13-1.15.

16. **Set RIGHT SIDE FWD and AFT MAIN FUEL PUMP switches (5 and 6) to OFF.**

FOLLOW-ON MAINTENANCE:

- TM 55-1520-240-23:
- Electrical power off.
- Battery disconnected.

TASK	RESULT
1. Check that CABIN HEATER CONT circuit breaker (1) is closed.	If circuit breaker (1) is open, close it. If it opens again, go to Task 13-1.5.
2. Check that CABIN HEATER BLOWER circuit breaker (2) is closed.	If circuit breaker (2) is open, close it. If it opens again, go to Task 13-1.6.
WARNING	
Cockpit vents must be closed before vent blower or heater is started. After blower or heater is started open vents slowly to prevent dirt and debris being blasted into air and eyes of personnel.	
3. Check that DEFOG or DEFROST AIR CONTROL handle (3) is all way down.	If handle (3) is up, push it down.
4. Check that PULL FOR COCKPIT AIR knob (4) on pilot and copilot instrument panel is against panel.	If either knob (4) is out, push it in.
5. Set RIGHT SIDE FWD and AFT MAIN FUEL PUMPS switches (5 and 6) to ON.	R FUEL PRESS capsule (7) shall go out. If it stays on, go to Task 10-2.4.
6. Set heater fan switch (8) to VENT. Blower only.	Heater fan shall run. If it can not be heard, go to Task 13-1.7.
7. Slowly pull out DEFOG or DEFROST AIR CONTROL handle (3).	Air shall be felt flowing from pilot and copilot jettisonable door defroster ducts (9) and nose bubble vents (10). If air flow is not felt at ducts or vents, go to Task 13-1.8.
8. Slowly pull out PULL FOR COCKPIT AIR knob (4) on pilot's instrument panel.	Air shall be felt flowing from pilot's outlet (11). If air flow is not felt, go to Task 13-1.9.
9. Slowly pull out PULL FOR COCKPIT AIR knob (4) on copilot's instrument panel.	Air shall be felt flowing from copilot's outlet (11). If air flow is not felt, go to Task 13-1.9.
10. Slowly pull out CABIN AIR AIR CONTROL handle (12).	Air shall be felt flowing out cabin vents (13). If air flow is not felt, go to Task 13-1.10.
11. Set heater fan switch (8) to HEATER ON.	Heater fan shall stop.
12. Turn CABIN TEMP SELECTOR knob (14) to WARMER.	

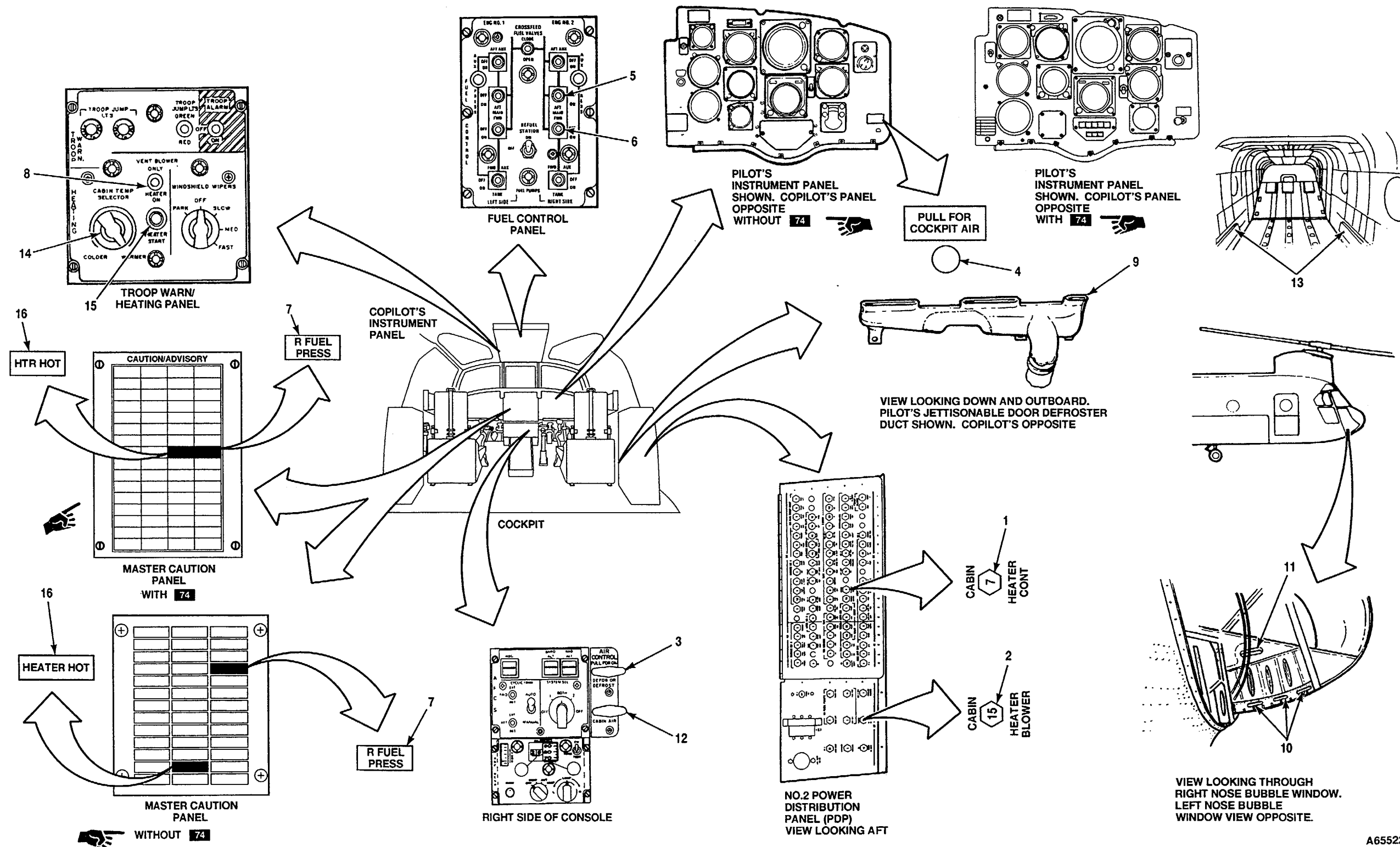

A65522

13-1.5 CABIN HEATER CONT CIRCUIT BREAKER WILL NOT STAY CLOSED

FAULT ISOLATION PROCEDURE

INITIAL SETUP

Applicable Configurations:

All

Tools:

- Electrical Repairer's Tool Kit.
- NSN 5180-00-323-4915
- Multimeter

Materials:

None

Personnel Required:

68F20 Aircraft Electrician

References:

TM 55-1520-240-23

Equipment Condition:

- TM 55-1520-240-20:
- Battery Disconnected
- Electrical Power Off
- Hydraulic Power Off
- Heater Compartment Acoustic Blanket Removed

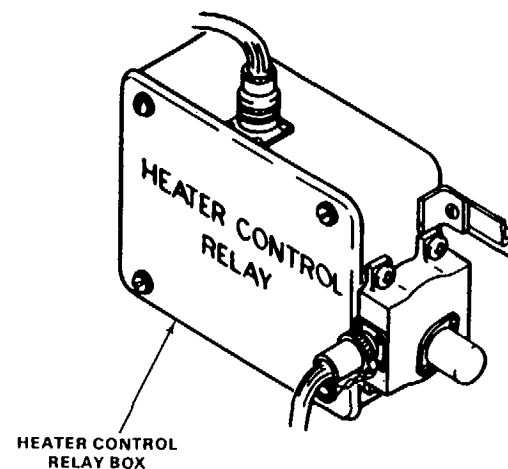

HEATER CONTROL RELAY BOX

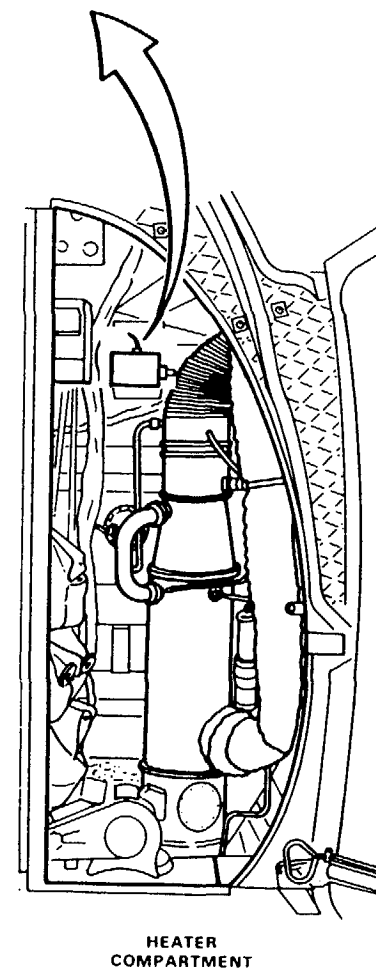

HEATER COMPARTMENT

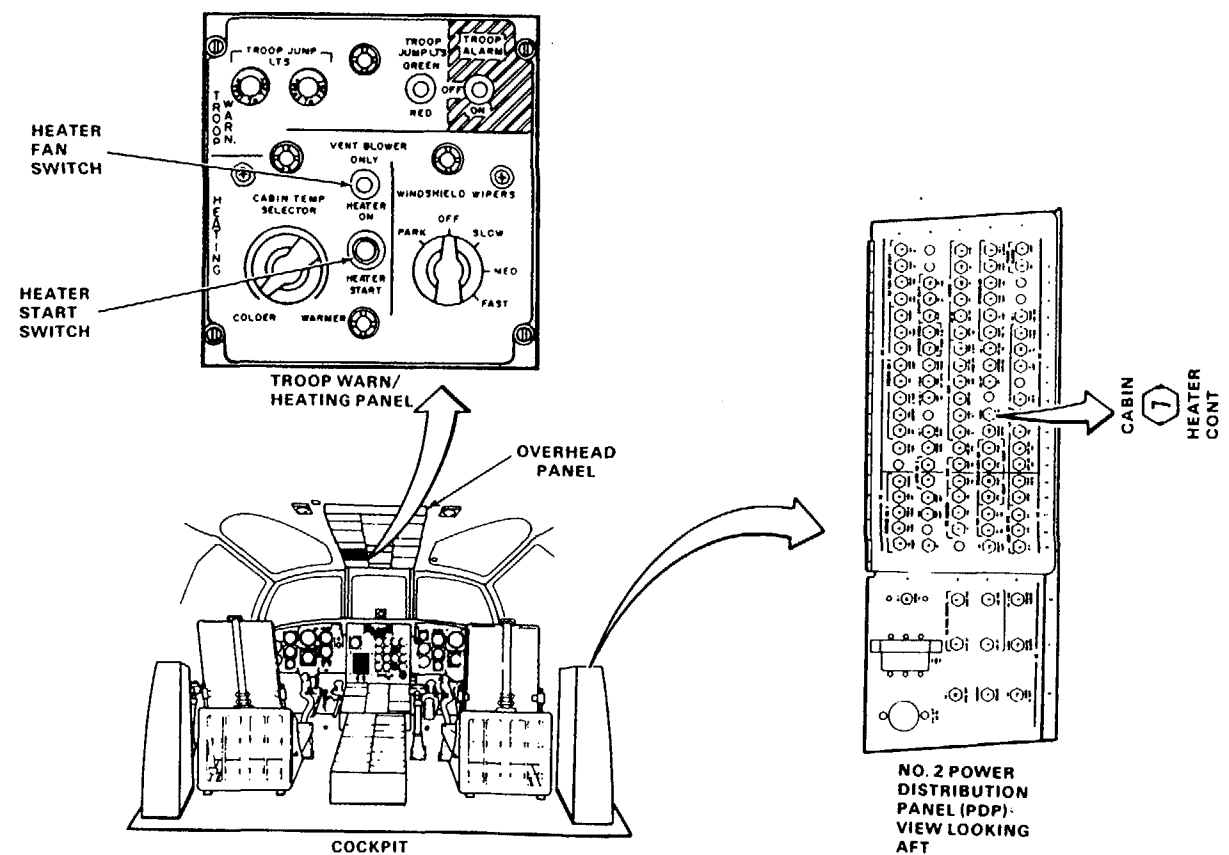

13-1.5 CABIN HEATER CONT CIRCUIT BREAKER WILL NOT STAY CLOSED (Continued)

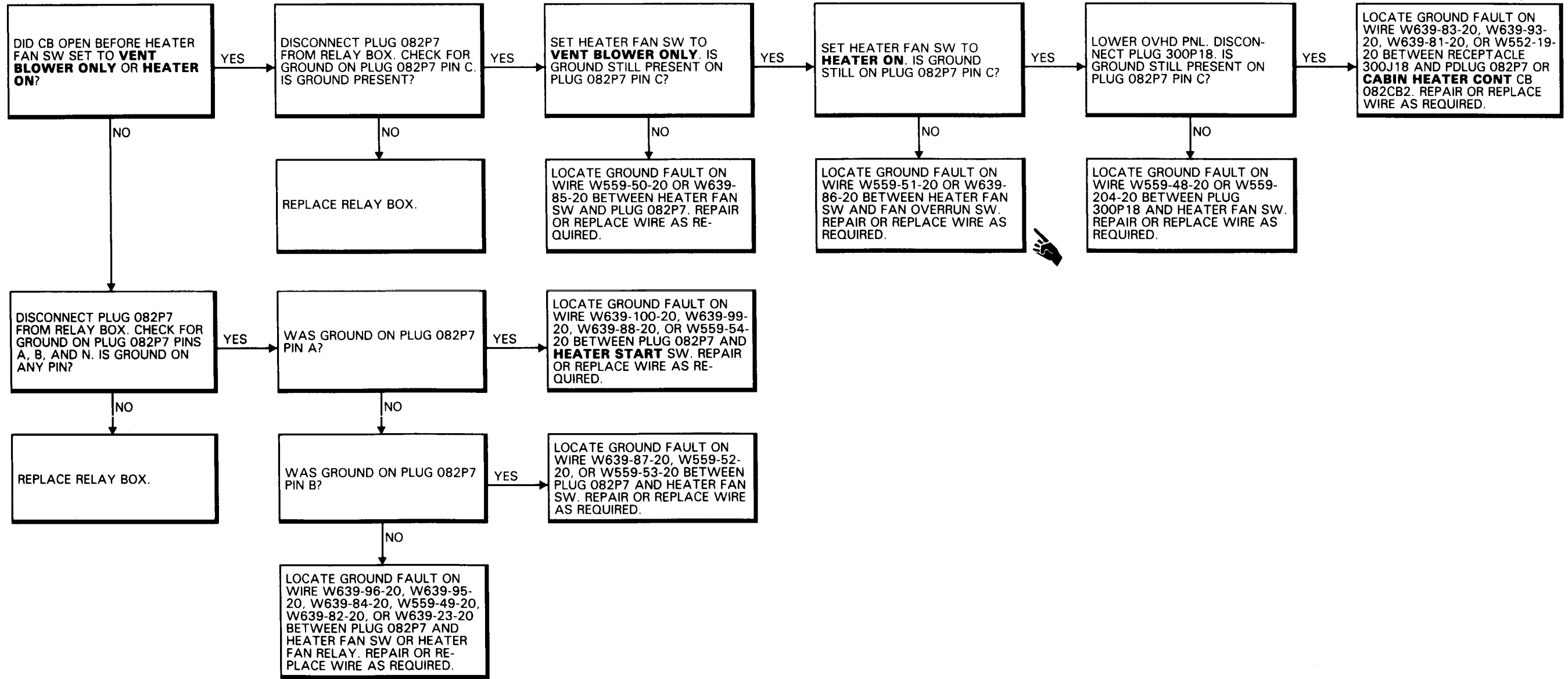

FAULT ISOLATION PROCEDURE

INITIAL SETUP

Applicable Configurations:

All

Tools:

Electrical Repairer's Tool Kit,
NSN 5180-00-323-4915

Multimeter

Materials:

None

Personnel Required:

Aircraft Electrician

References:

TM 55-1520-240-23

Equipment Condition:

TM 55-1520-240-23:

Battery Disconnected

Electrical Power Off

Hydraulic Power Off

Heater Compartment Acoustic Blanket Removed

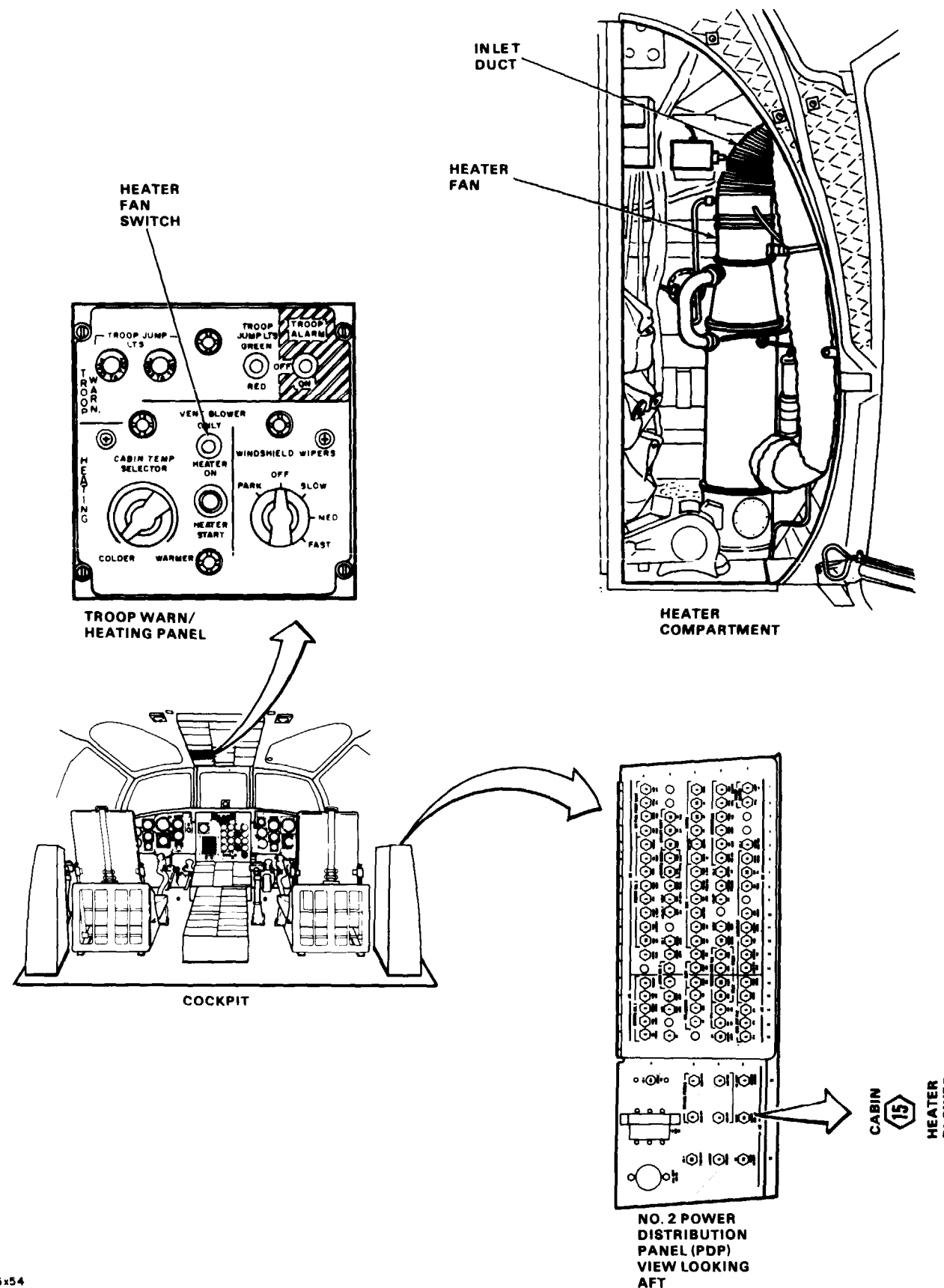
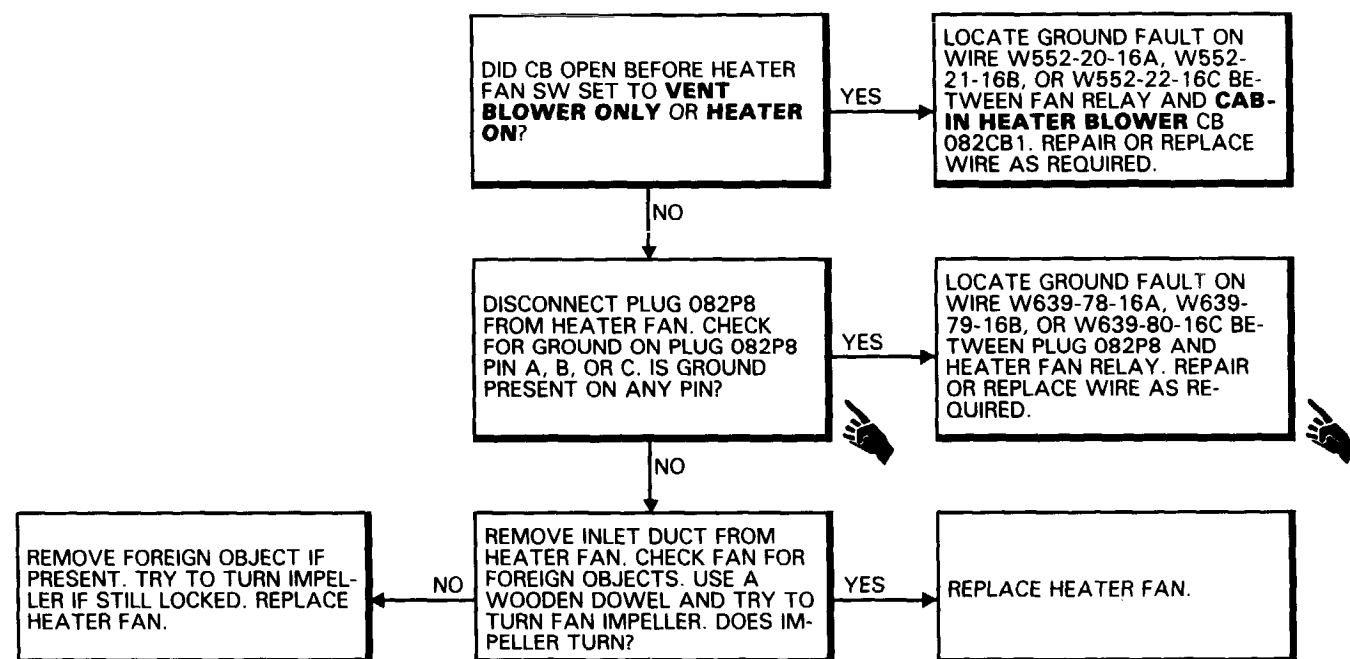

45x54

D145-8081-SPA

FAULT ISOLATION PROCEDURE

INITIAL SETUP

Applicable Configurations:
All

Tools:
Electrical Repairer's Tool Kit,
NSN 5180-00-323-4915
Multimeter

Materials:
None

Personnel Required:
68F10 Aircraft Electrician
68F20 Aircraft Electrician

References:
TM 55-1520-240-23

Equipment Condition:
TM 55-1520-240-23:
Battery Connected
Electrical Power On
Hydraulic Power Off
Heater Compartment Acoustic
Blanket Removed

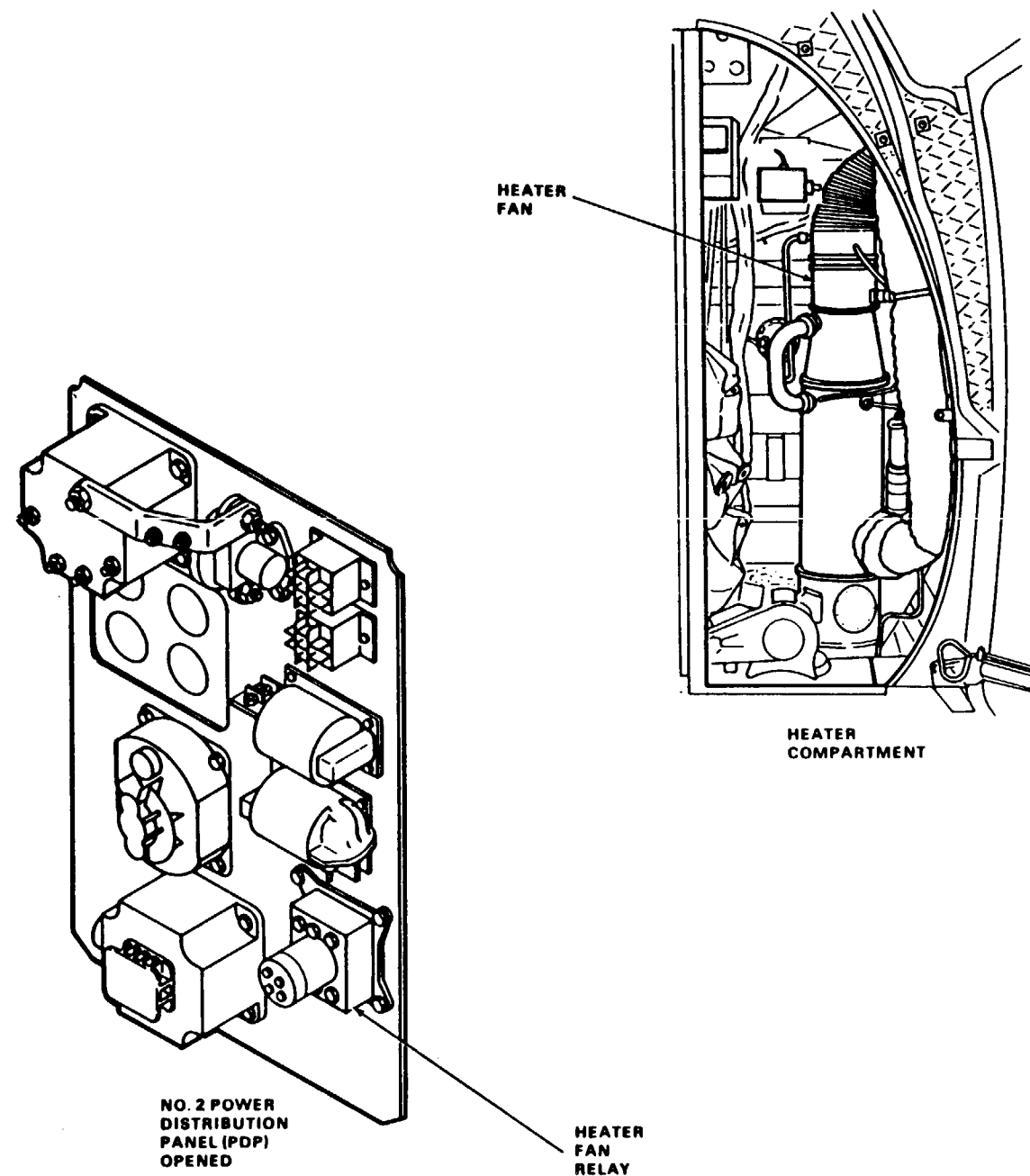
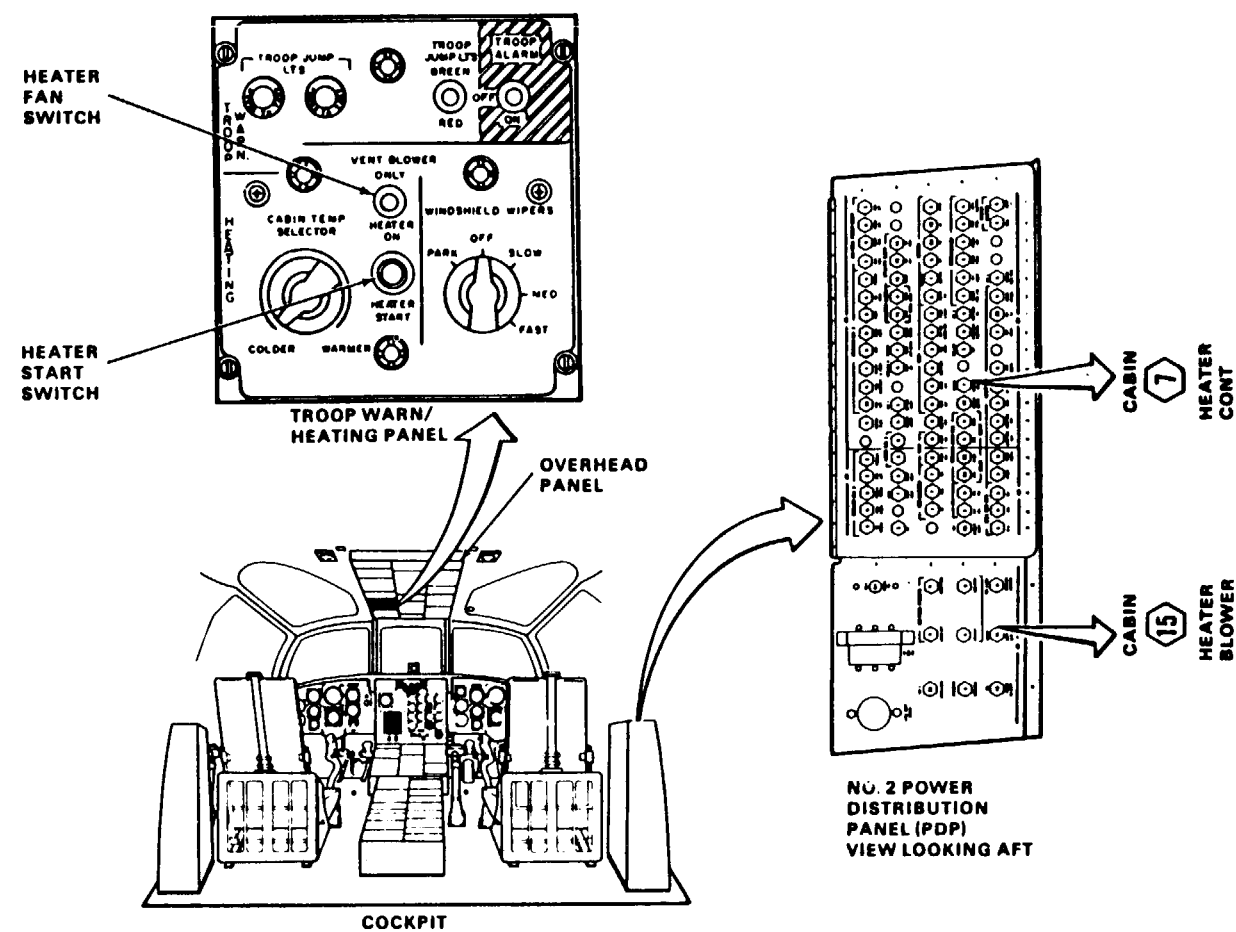

13-1.7 HEATER FAN CANNOT BE HEARD RUNNING (Continued)

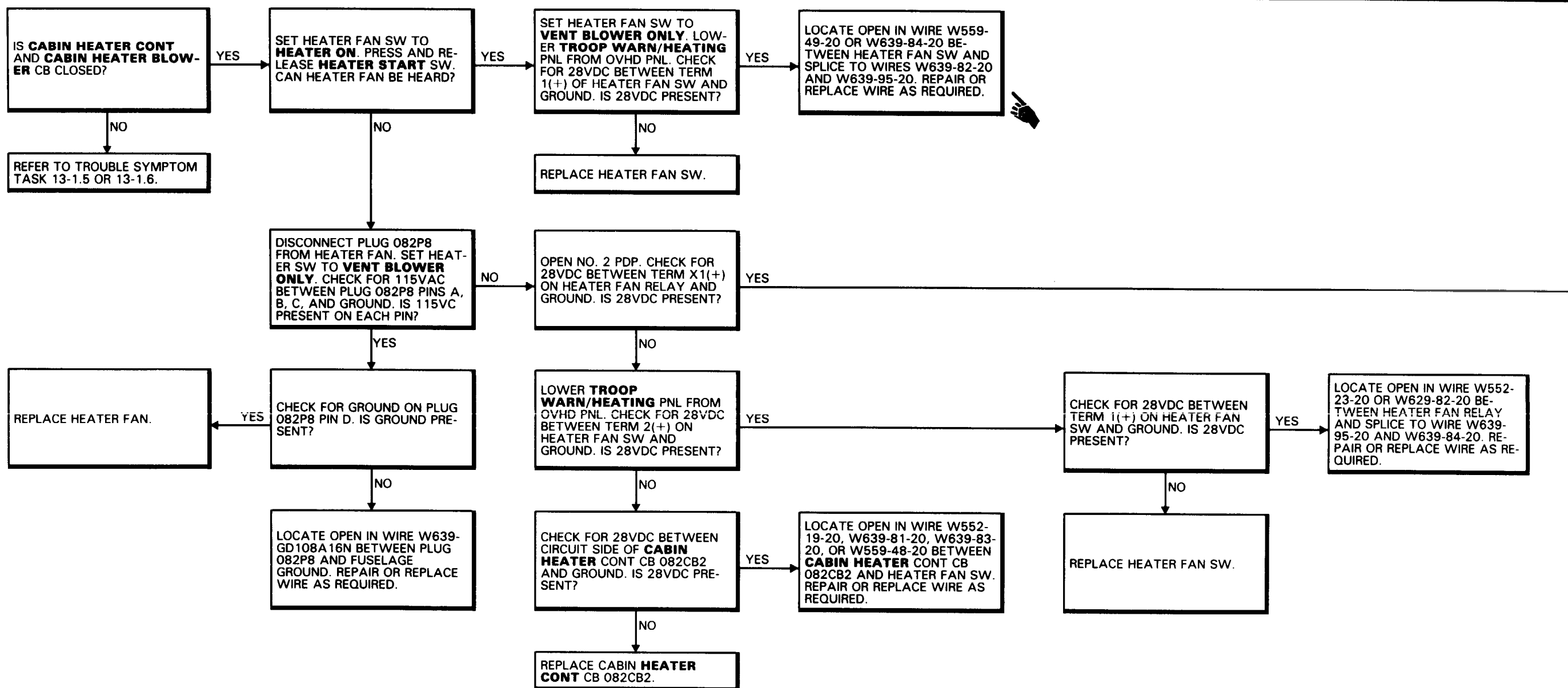

13-1.7 HEATER FAN CANNOT BE HEARD RUNNING (Continued)

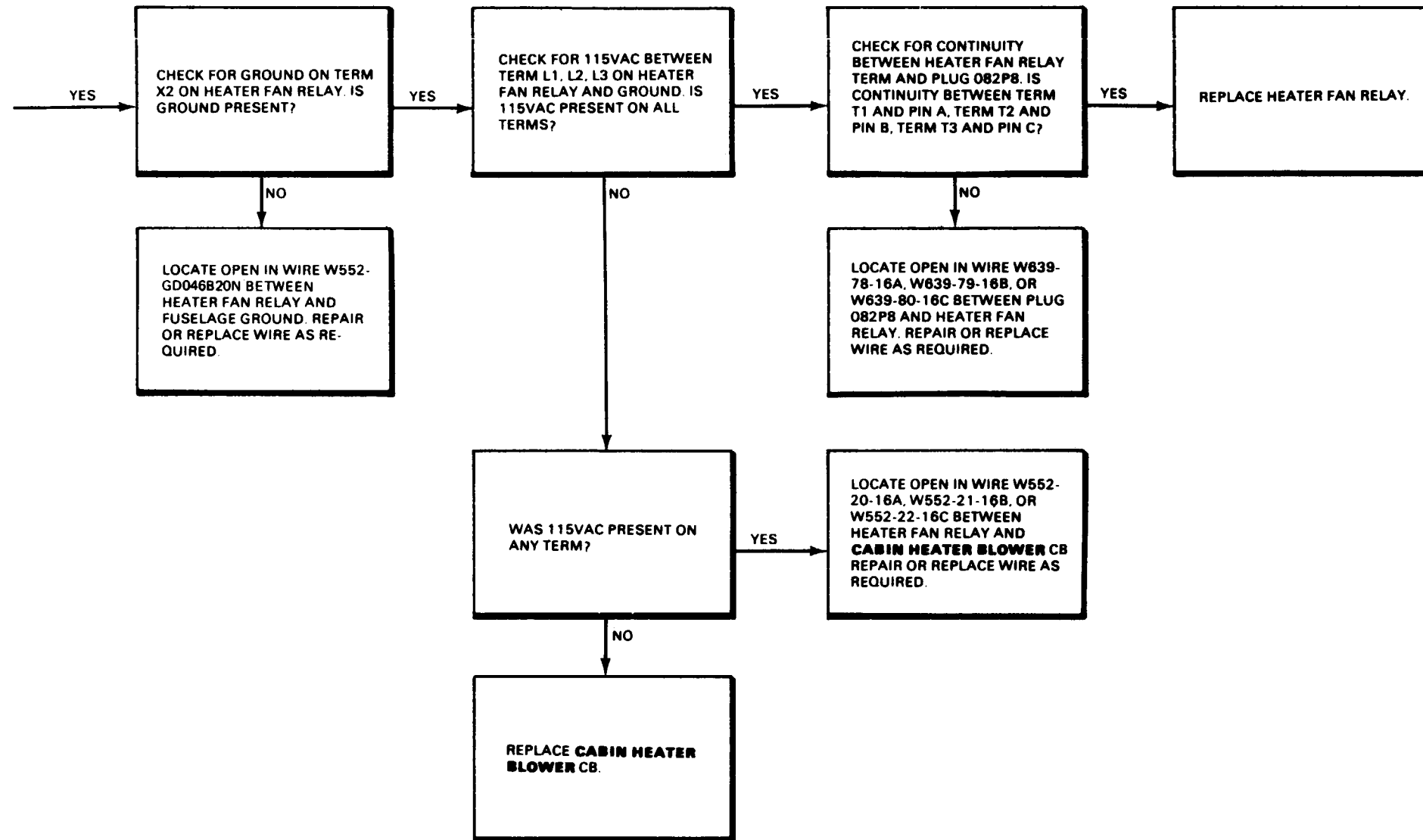

GO TO NEXT PAGE

13-1.7 HEATER FAN CANNOT BE HEARD RUNNING (Continued)

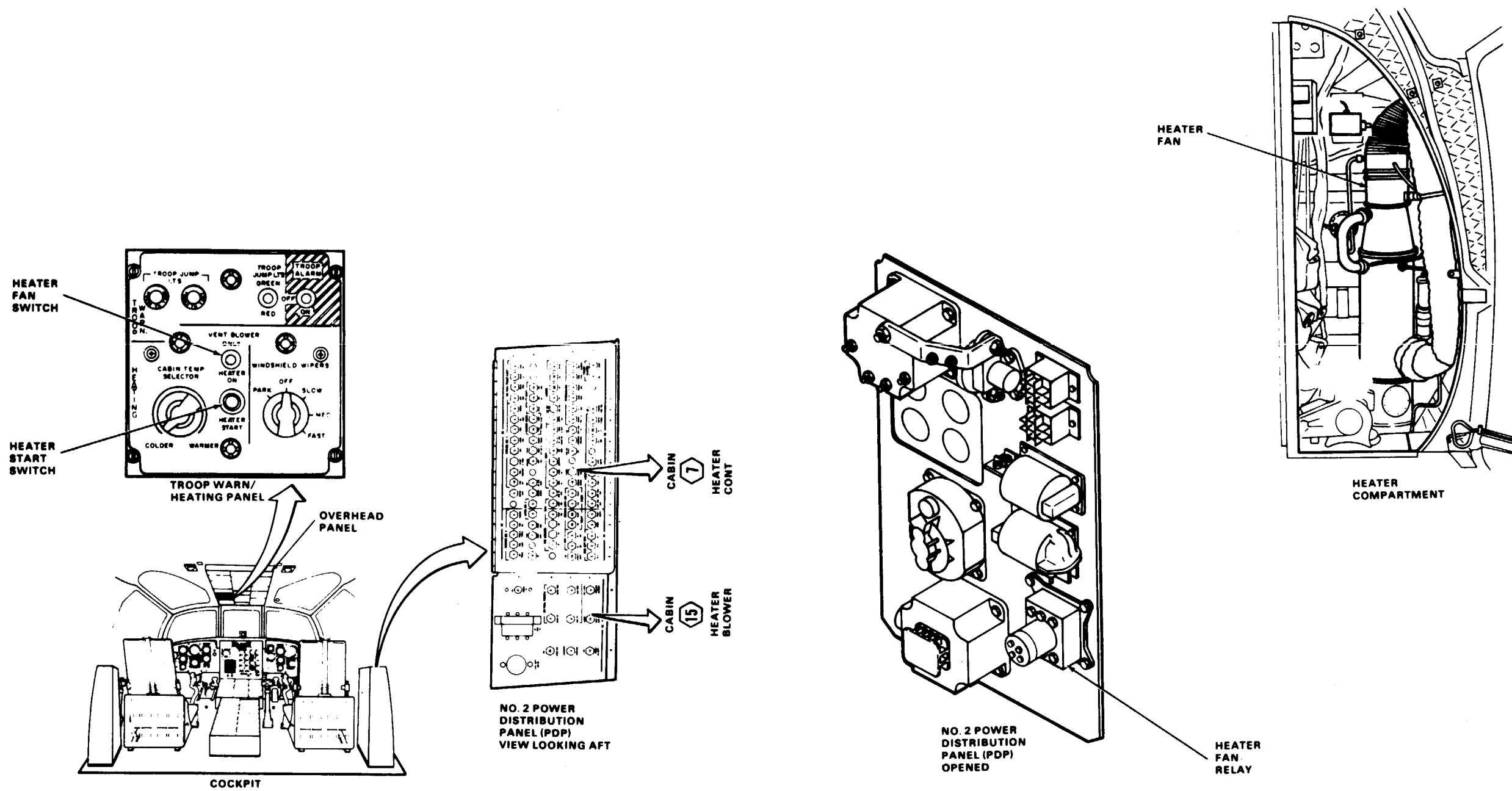

13-1.8 AIR FLOW NOT FELT AT JETTISONABLE DOOR DEFROSTER DUCTS OR NOSE BUBBLE VENTS

FAULT ISOLATION PROCEDURE

INITIAL SETUP

Applicable Configurations:
All

References:
TM 55-1520-240-23

Tools:
Aircraft Mechanic's Tool Kit,
NSN 5180-00-323-4692

Equipment Condition:
TM 55-1520-240-23:
Battery Disconnected
Electrical Power Off
Hydraulic Power Off
Passageway Floor Removed
Heater Compartment Acoustic Blanket
Removed

Materials:
None

Personnel Required:
67U20 Medium Helicopter Repairer

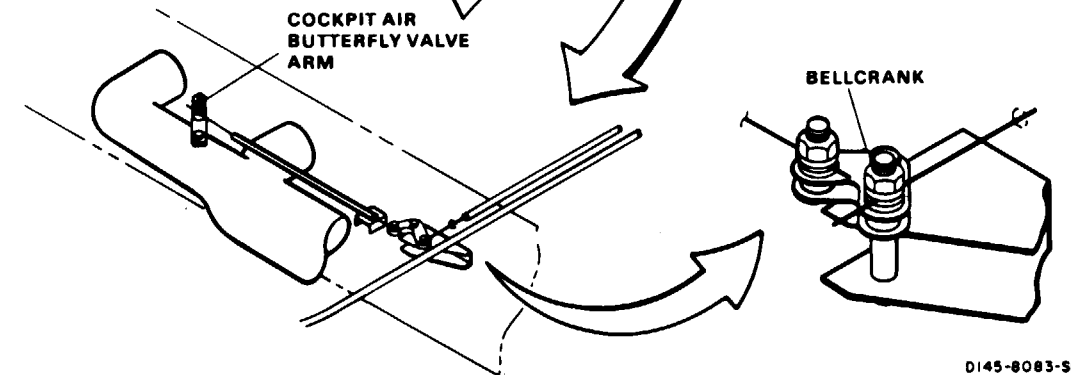
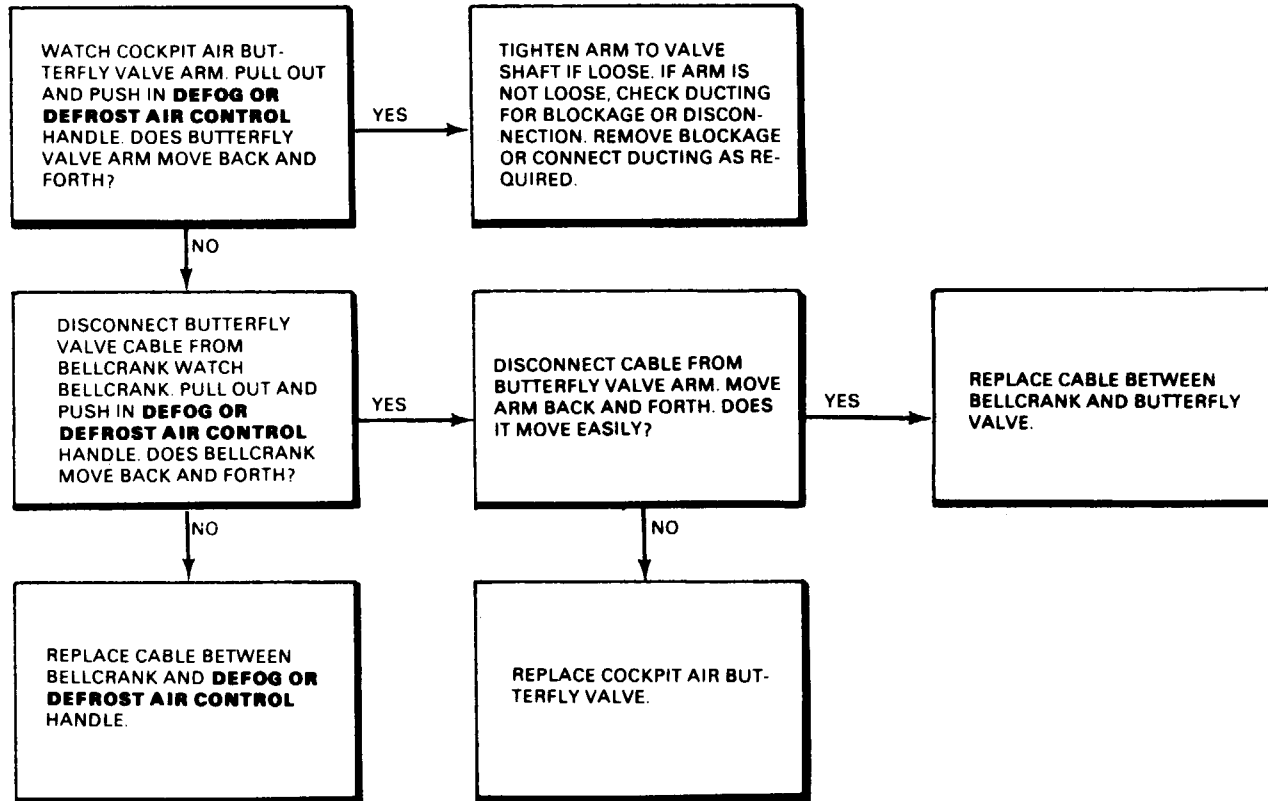
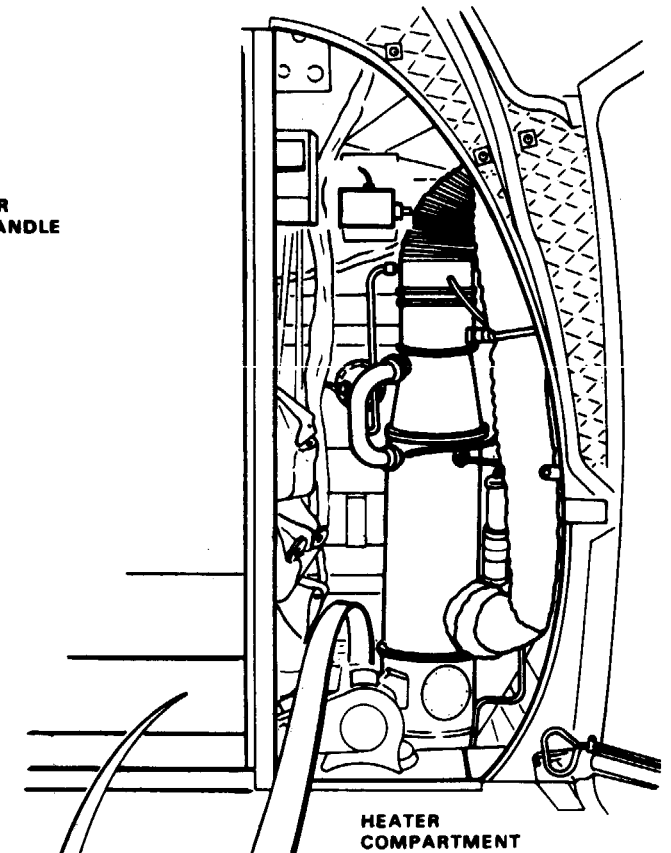
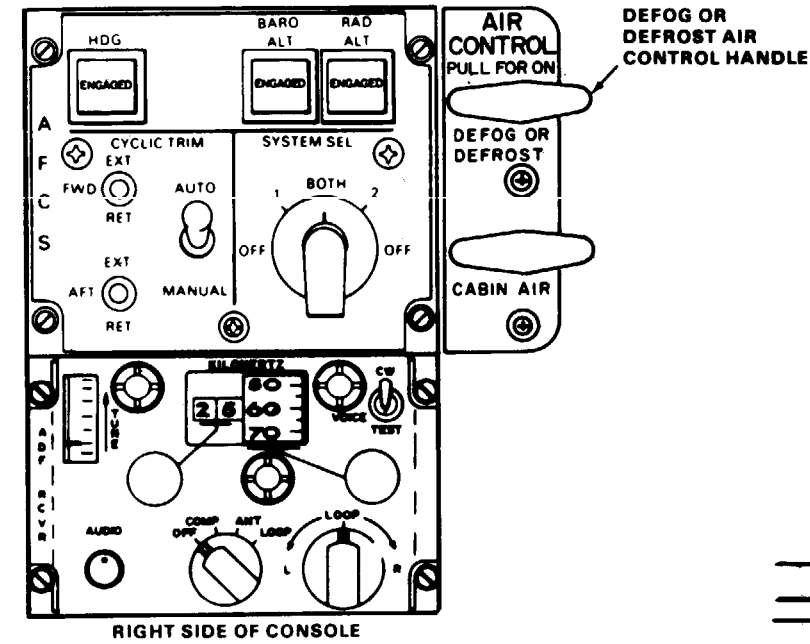
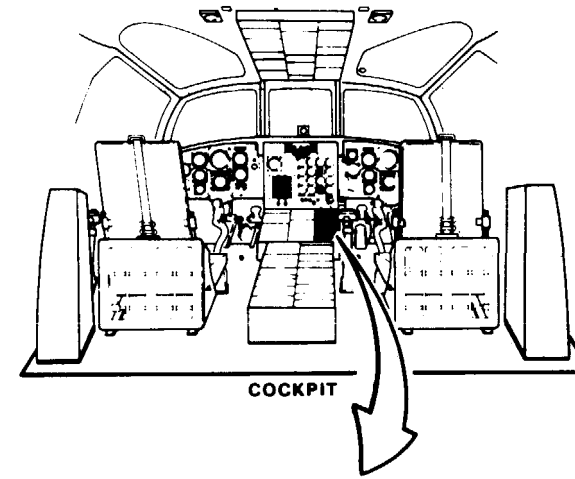

13-1.9 AIR FLOW NOT FELT AT PILOT OR COPILOT AIR OUTLET

FAULT ISOLATION PROCEDURE

INITIAL SETUP

Applicable Configurations:

All

Tools:

Aircraft Mechanic's Tool Kit,
NSN 5180-00-323-4692

Materials:

None

Personnel Required:
67U20 Medium Helicopter Repairer

References:
TM 55-1520-240-23

Equipment Condition:
TM 55-1520-240-23:
Battery Disconnected
Electrical Power Off
Hydraulic Power Off

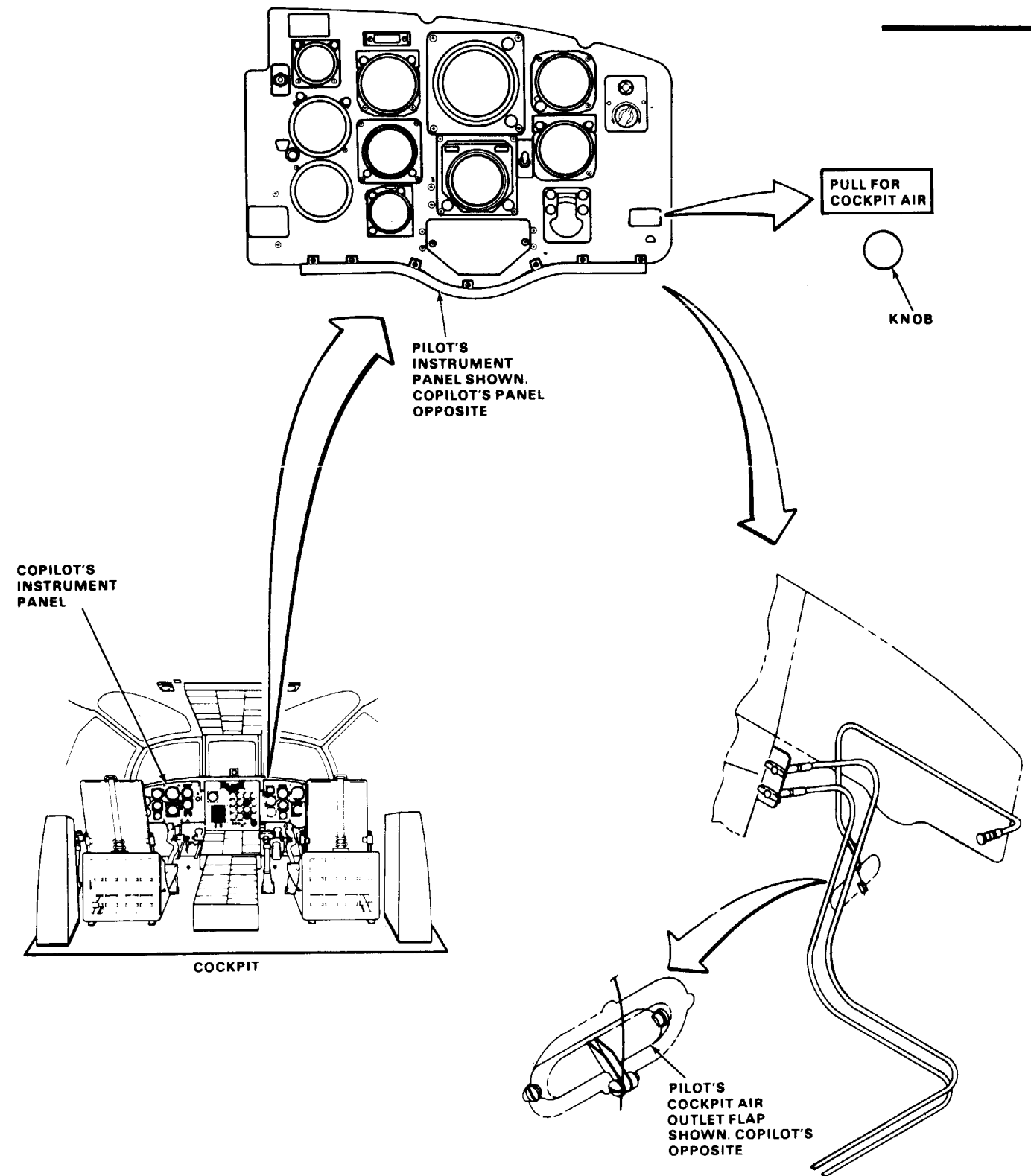
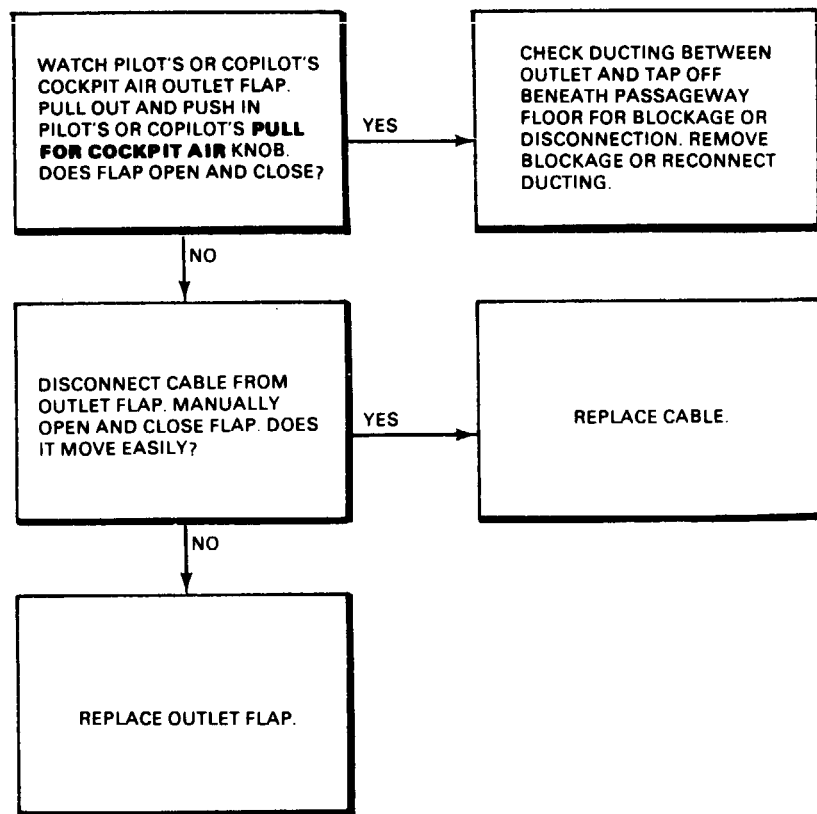

13-1.10 AIR FLOW NOT FELT AT CABIN VENTS

FAULT ISOLATION PROCEDURE

INITIAL SETUP

Applicable Configurations:

All

Tools:

Aircraft Mechanic's Tool Kit,
NSN 5180-00-323-4692

Materials:

None

Personnel Required:

67U10 Medium Helicopter Repairer
67U20 Medium Helicopter Repairer

References:

TM 55-1520-240-23

Equipment Condition:

TM 55-1520-240-23:
Battery Disconnected
Electrical Power Off
Hydraulic Power Off

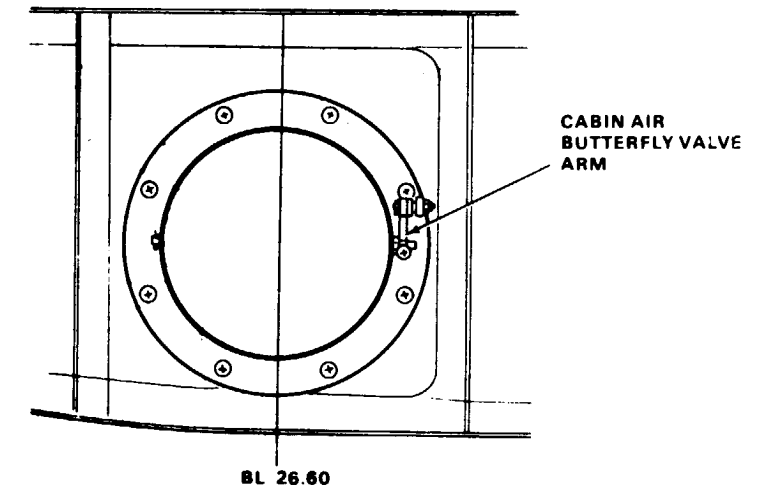
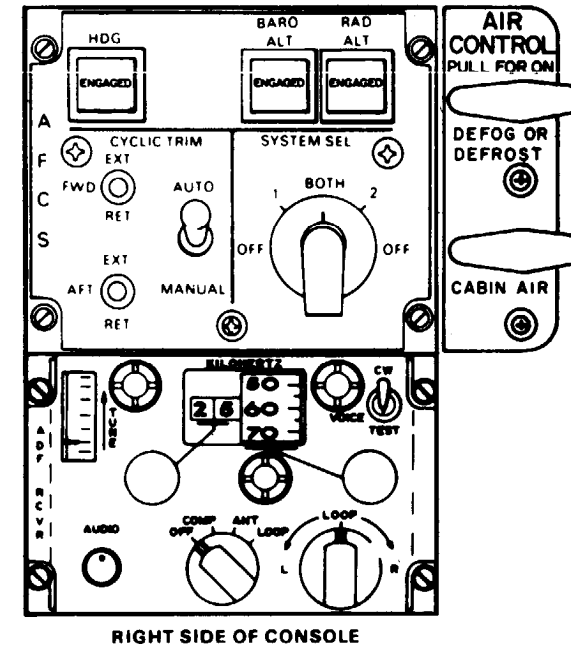
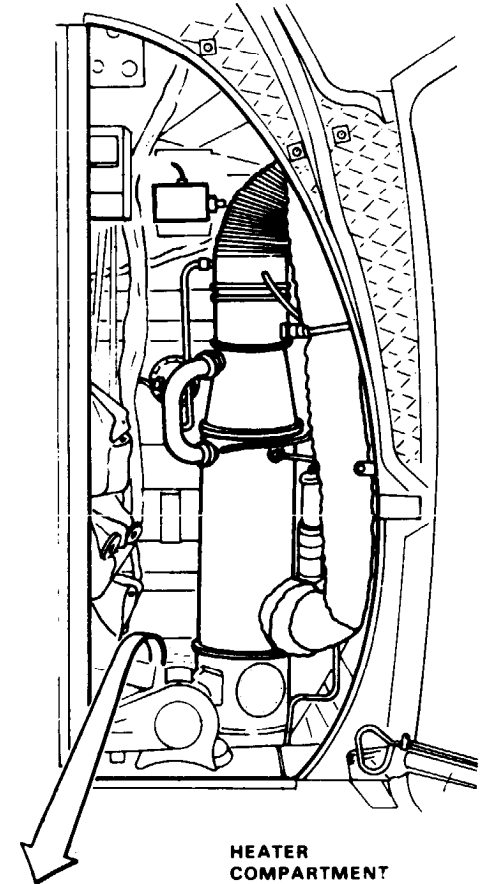
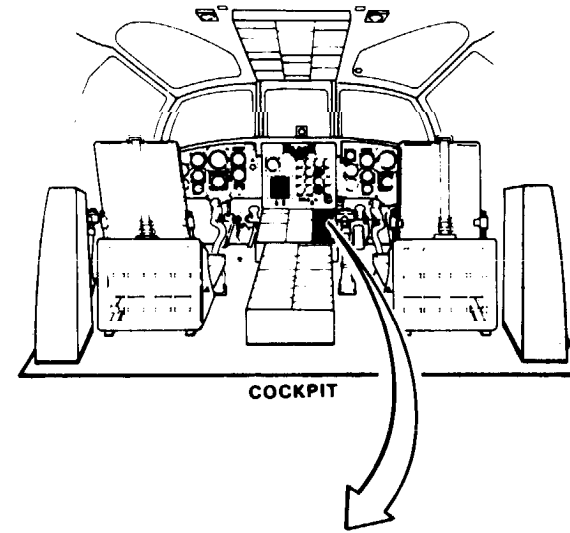

VIEW LOOKING AFT AT STA 120

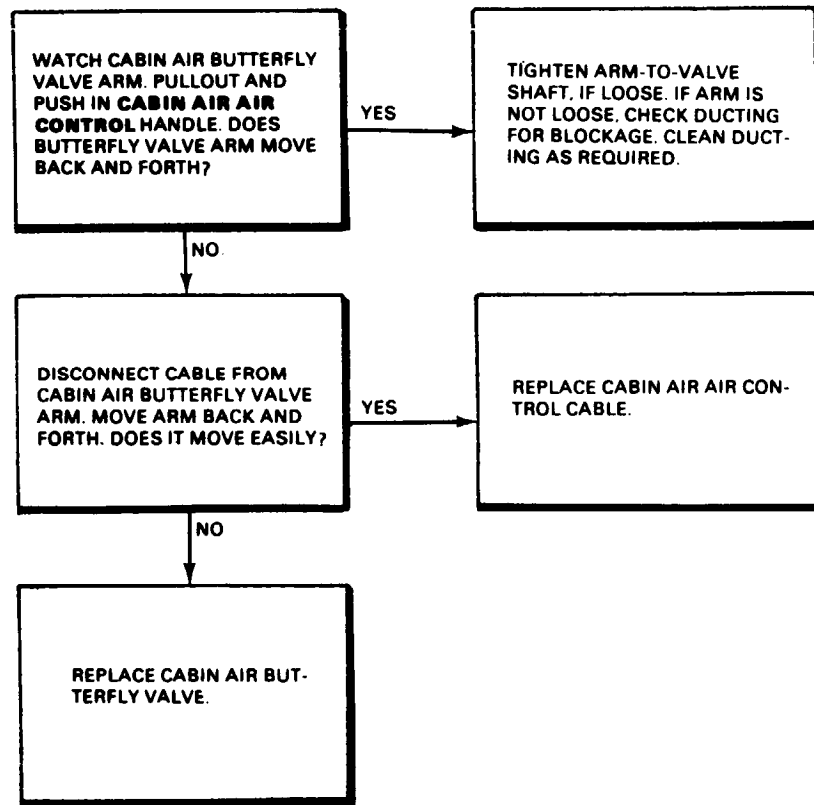

13-1.11 HEATER FAN CAN NOT BE HEARD RUNNING AFTER
HEATER START SWITCH PRESSED AND RELEASED

FAULT ISOLATION PROCEDURE

INITIAL SETUP

Applicable Configurations:
All

References:
TM 55-1520-240-23

Tools:
Electrical Repairer's Tool Kit,
NSN 5180-00-323-4915
Multimeter

Equipment Condition:
TM 55-1520-240-23:
Battery Connected
Electrical Power On
Hydraulic Power Off
Heater Compartment Acoustic Blanket
Removed

Materials:
None

Personnel Required:
68F10 Aircraft Electrician
68F20 Aircraft Electrician

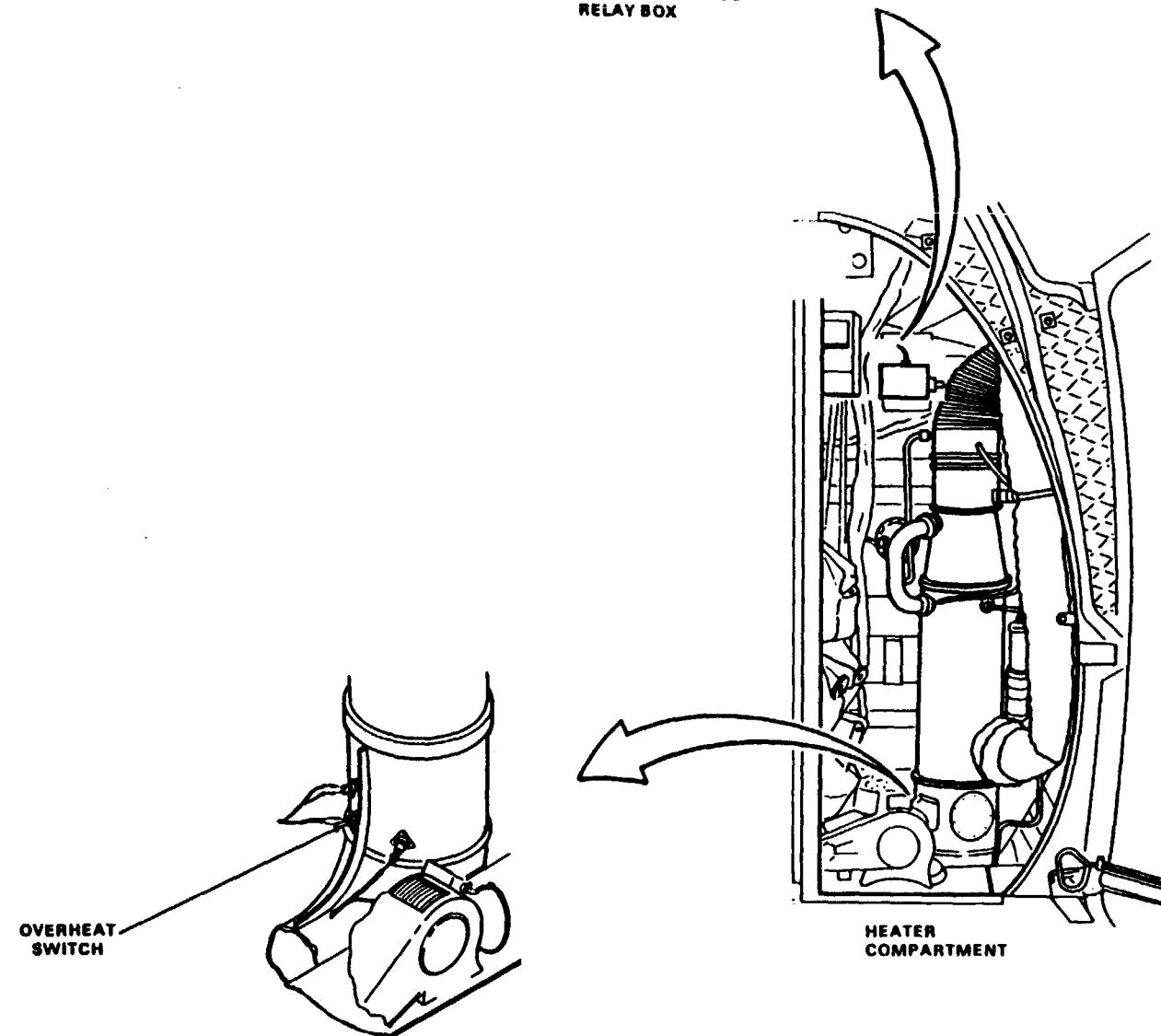
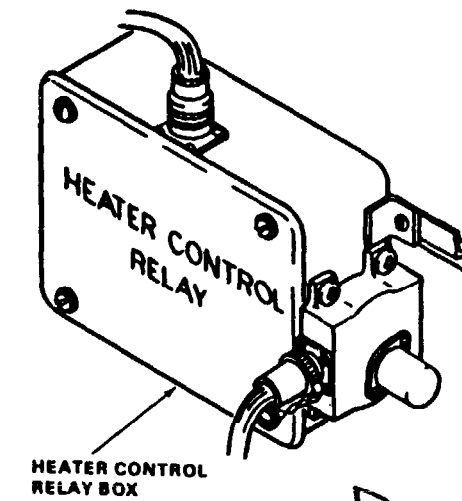
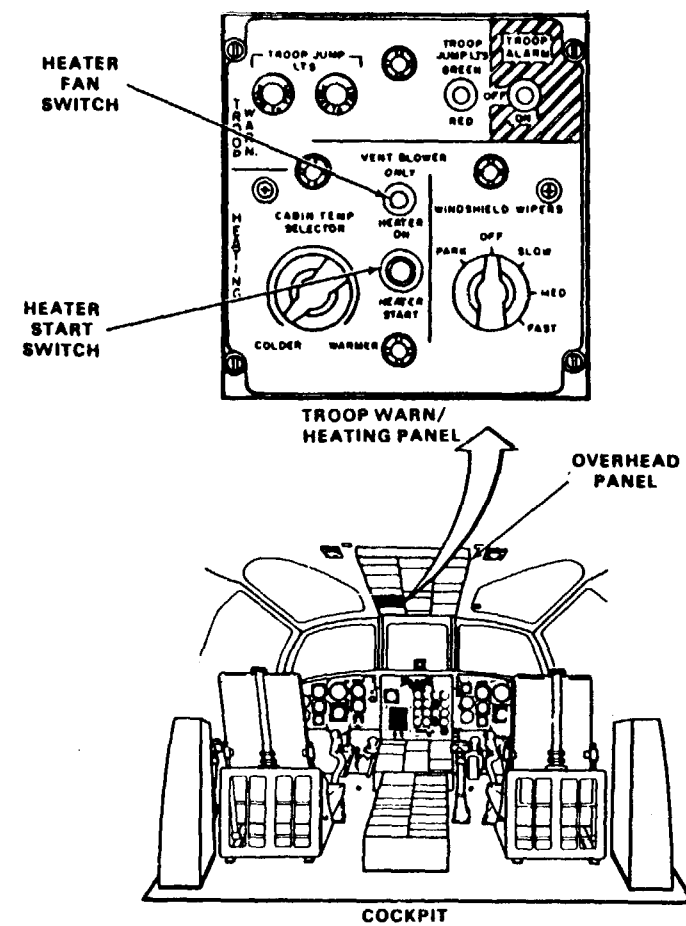

Page 13-19 is a blank page.

D145-8085-SPA
GO TO NEXT PAGE

13-1.11 HEATER FAN CAN NOT BE HEARD RUNNING AFTER HEATER START SWITCH PRESSED AND RELEASED
(Continued)

13-1.11

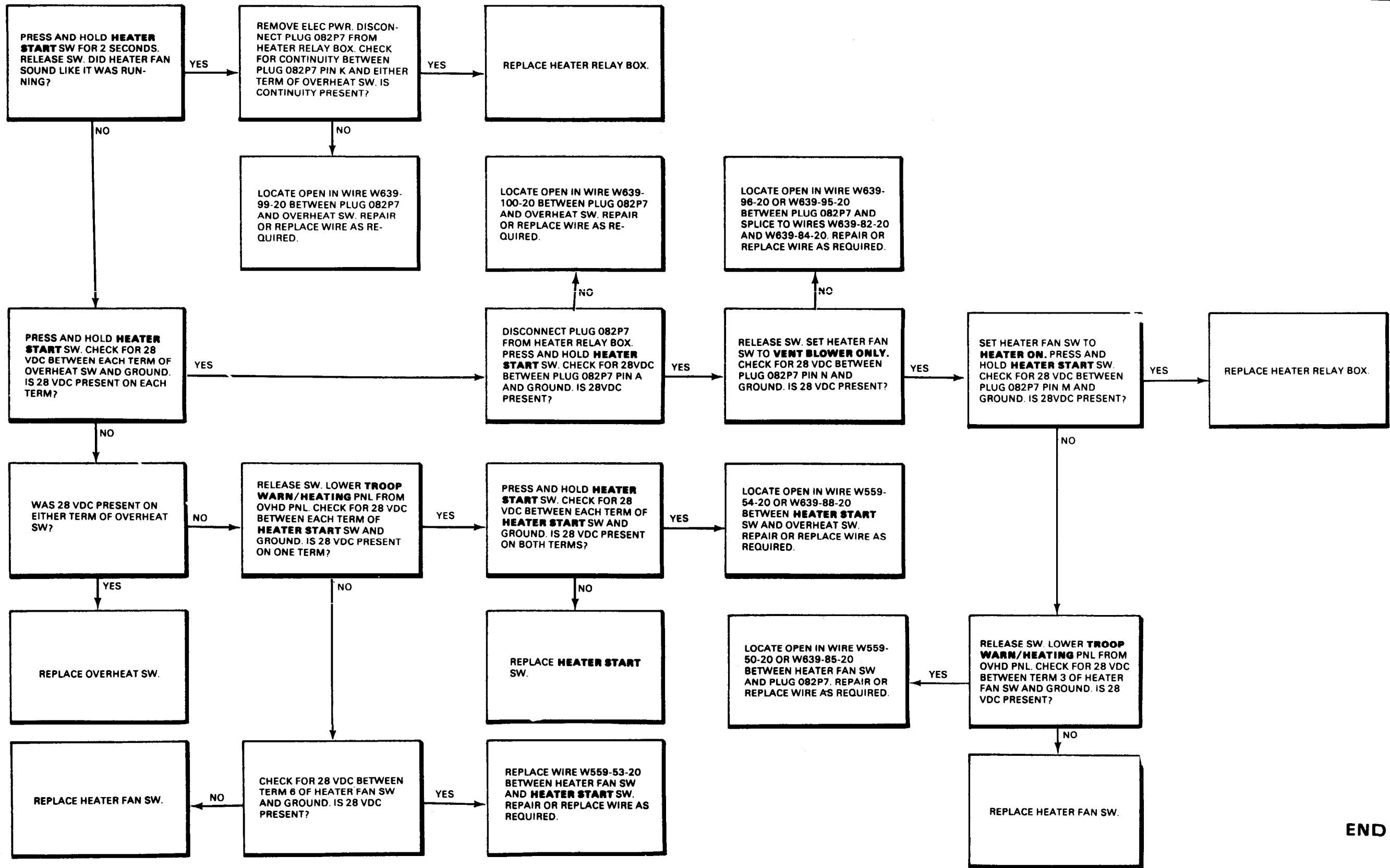

END OF TASK

13-1.12 HEATER DOES NOT PROVIDE WARM AIR

FAULT ISOLATION PROCEDURE

INITIAL SETUP

Applicable Configurations:
All

Tools:
Electrical Repairer's Tool Kit,
NSN 5180-00-323-4915
Multimeter
Stopwatch

Materials:
None

Personnel Required:
67U10 Medium Helicopter Repairer
68F20 Aircraft Electrician

References:
TM 55-1520-240-23

Equipment Condition:
TM 55-1520-240-23:
Battery Connected
Electrical Power On
Hydraulic Power Off
Heater Compartment Acoustic Blanket
Removed

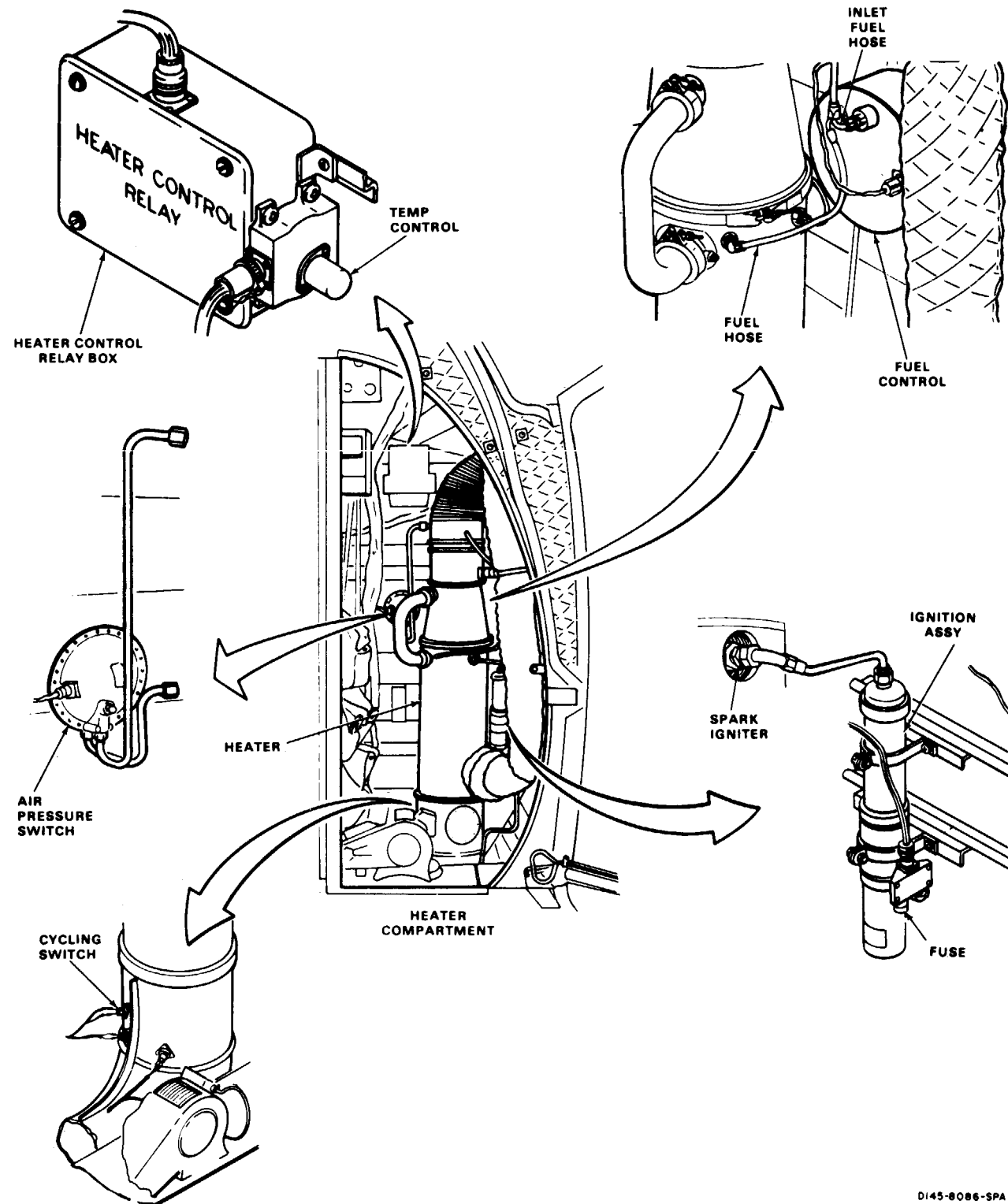
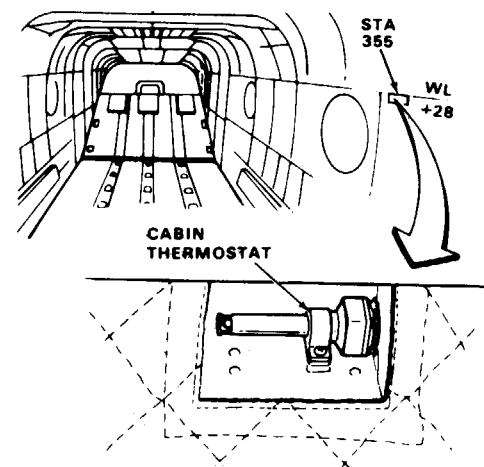
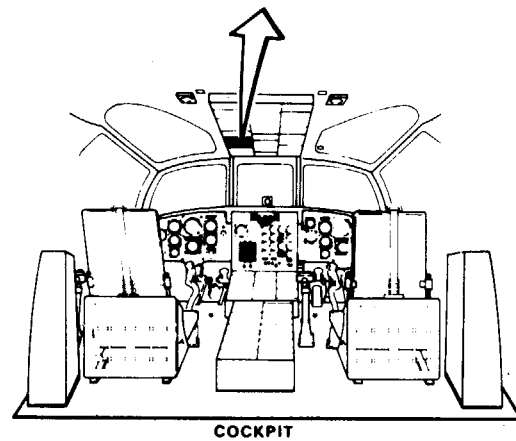
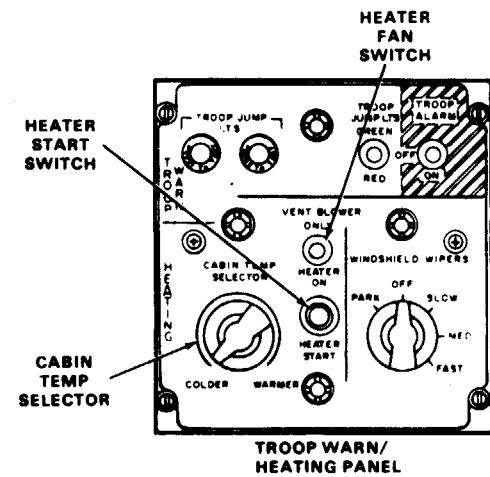

90:54

D145-8086-SPA

GO TO NEXT PAGE

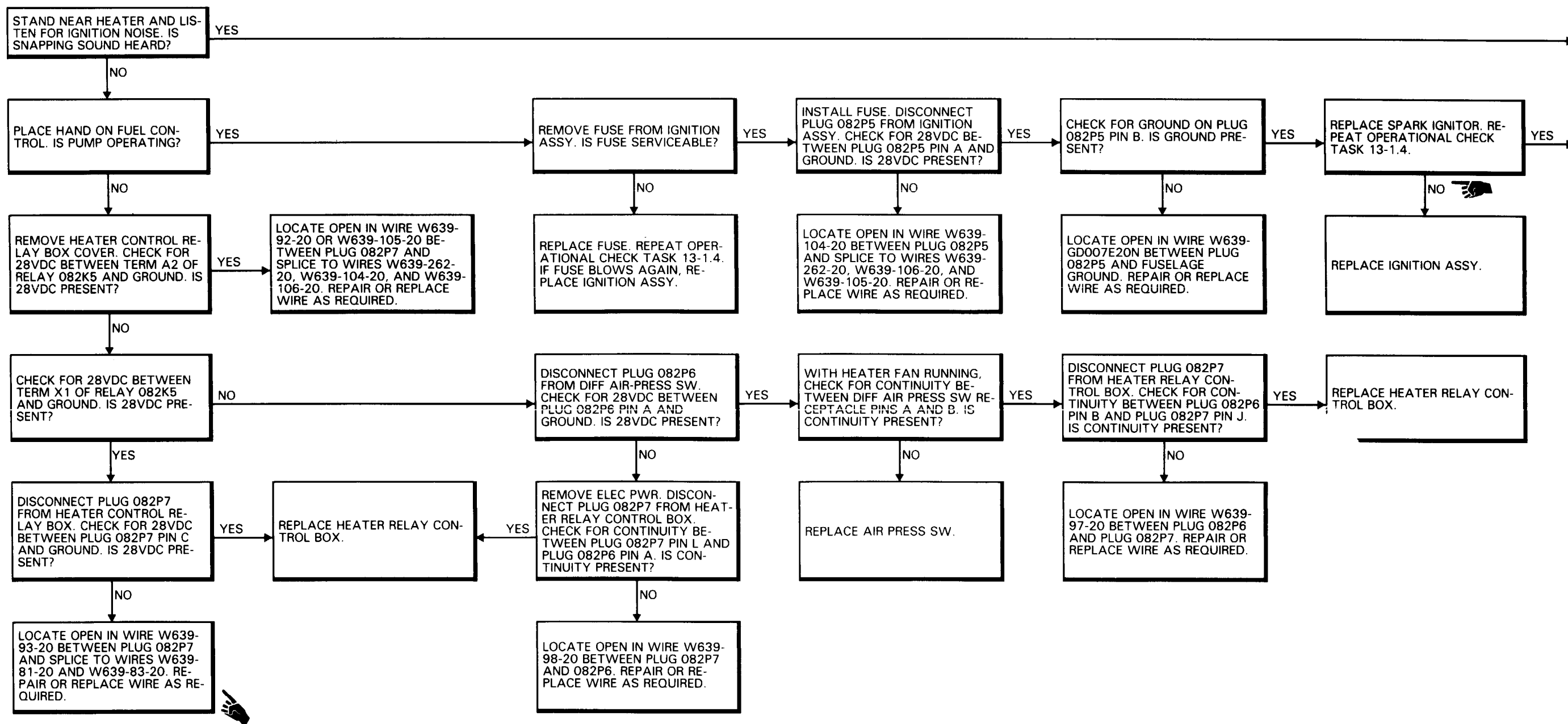

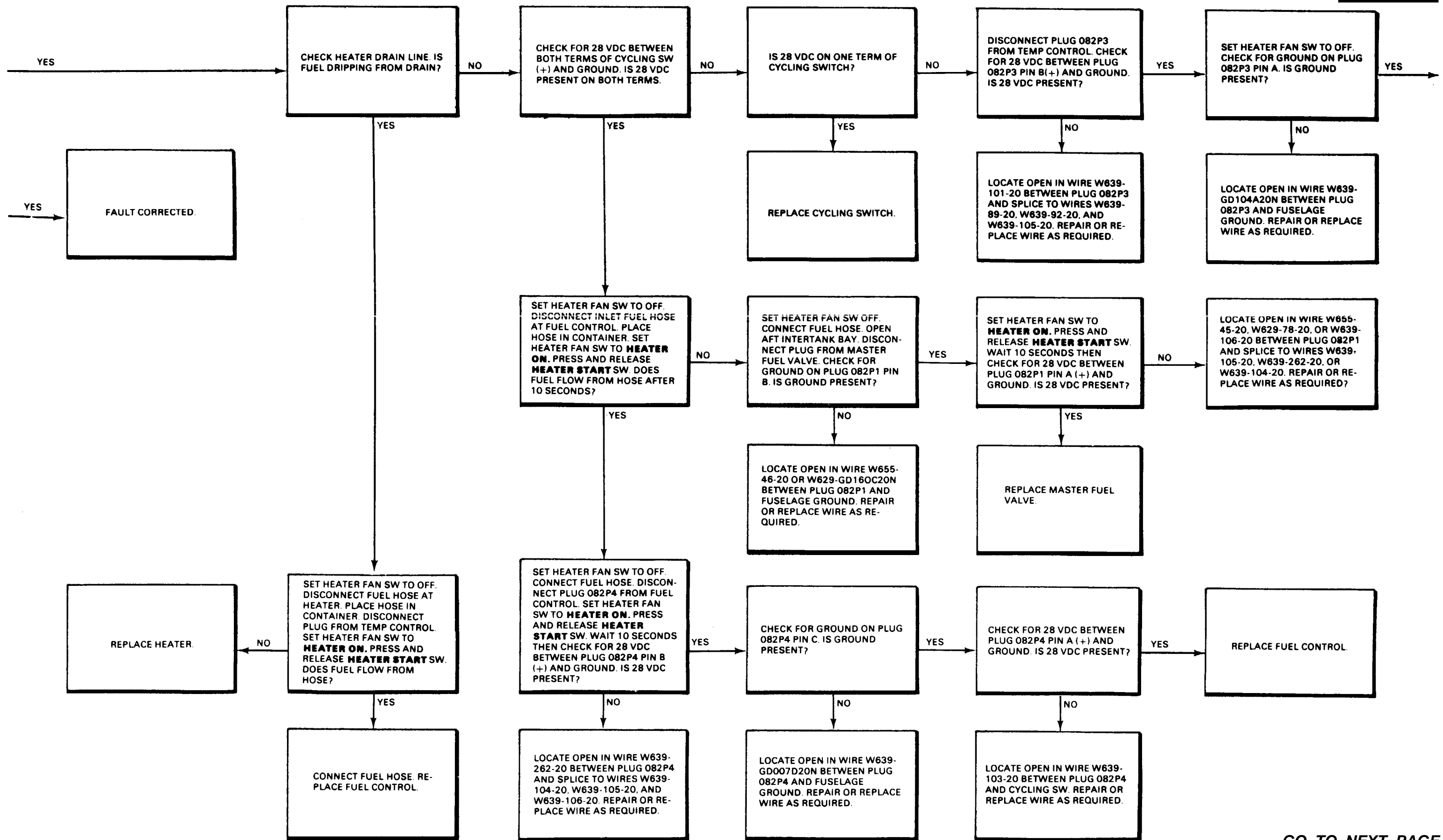

13-1.12 HEATER DOES NOT PROVIDE WARM AIR (Continued)

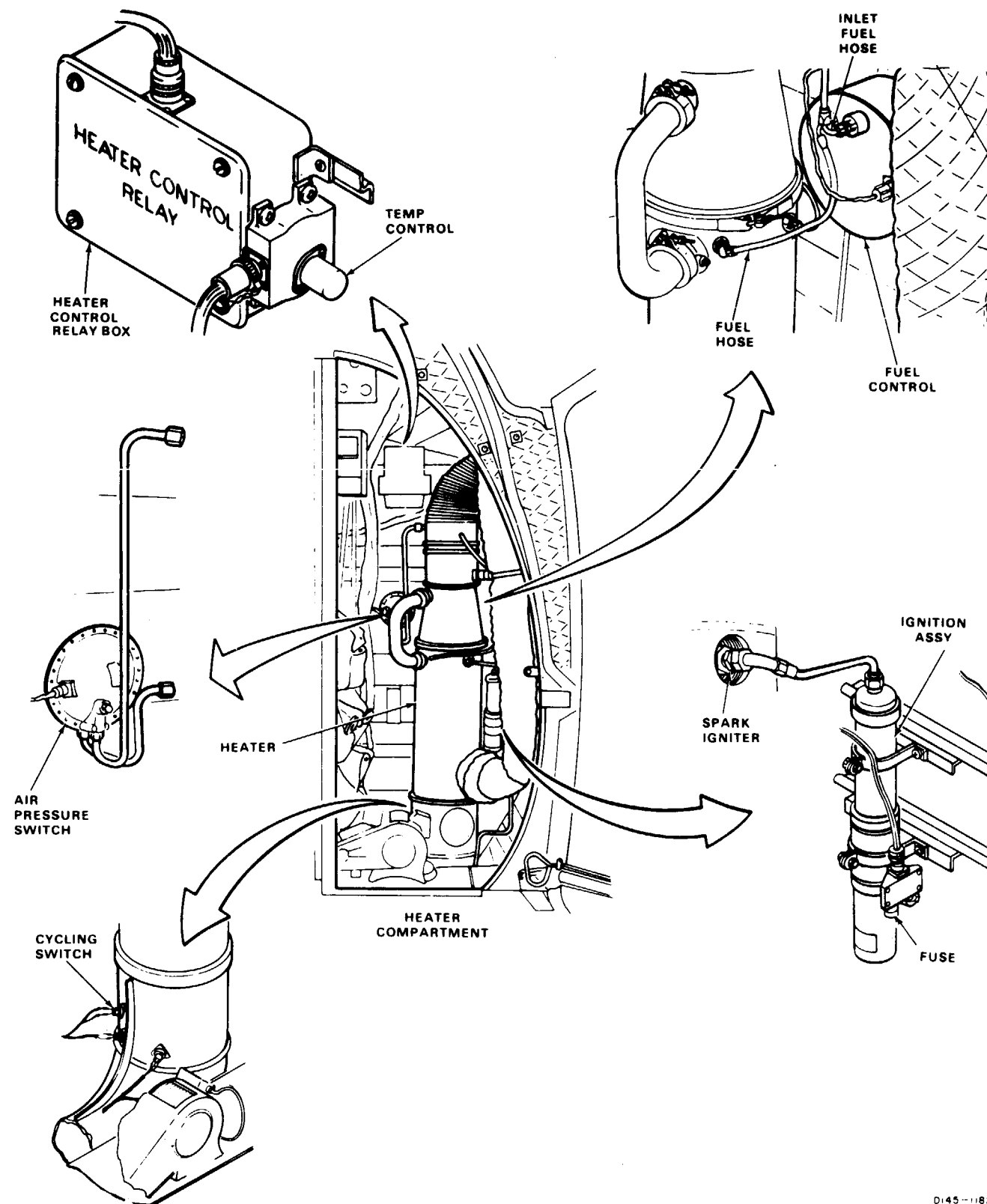
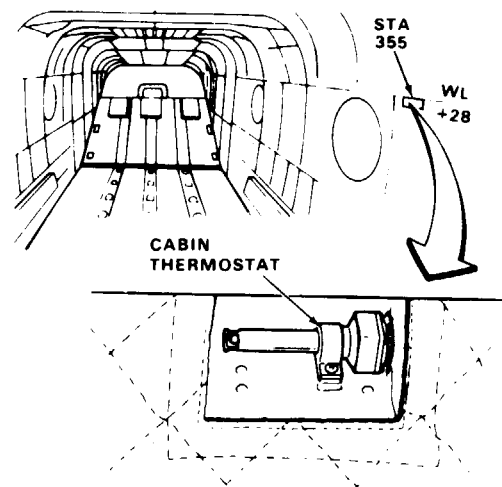
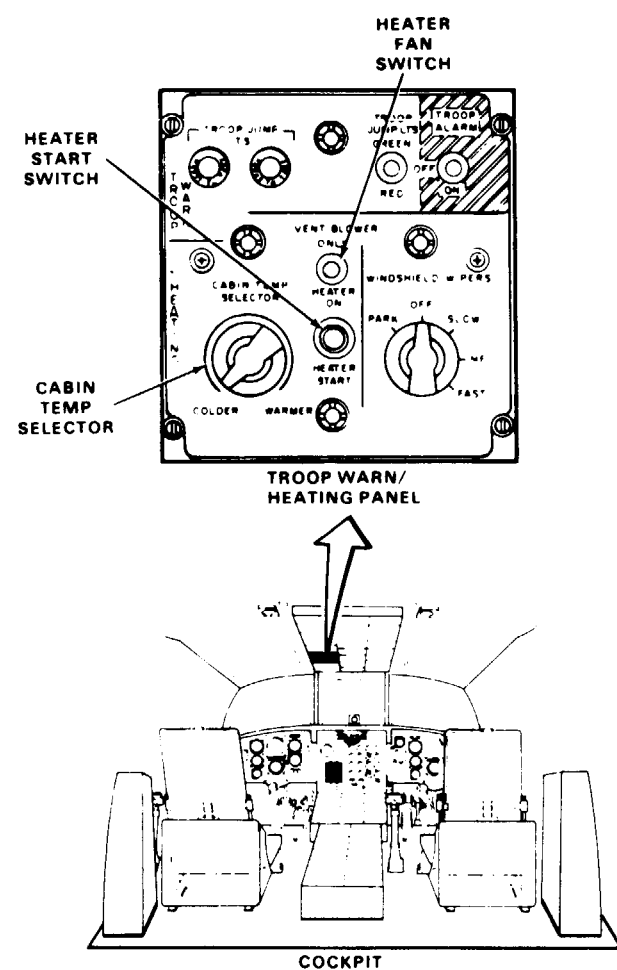

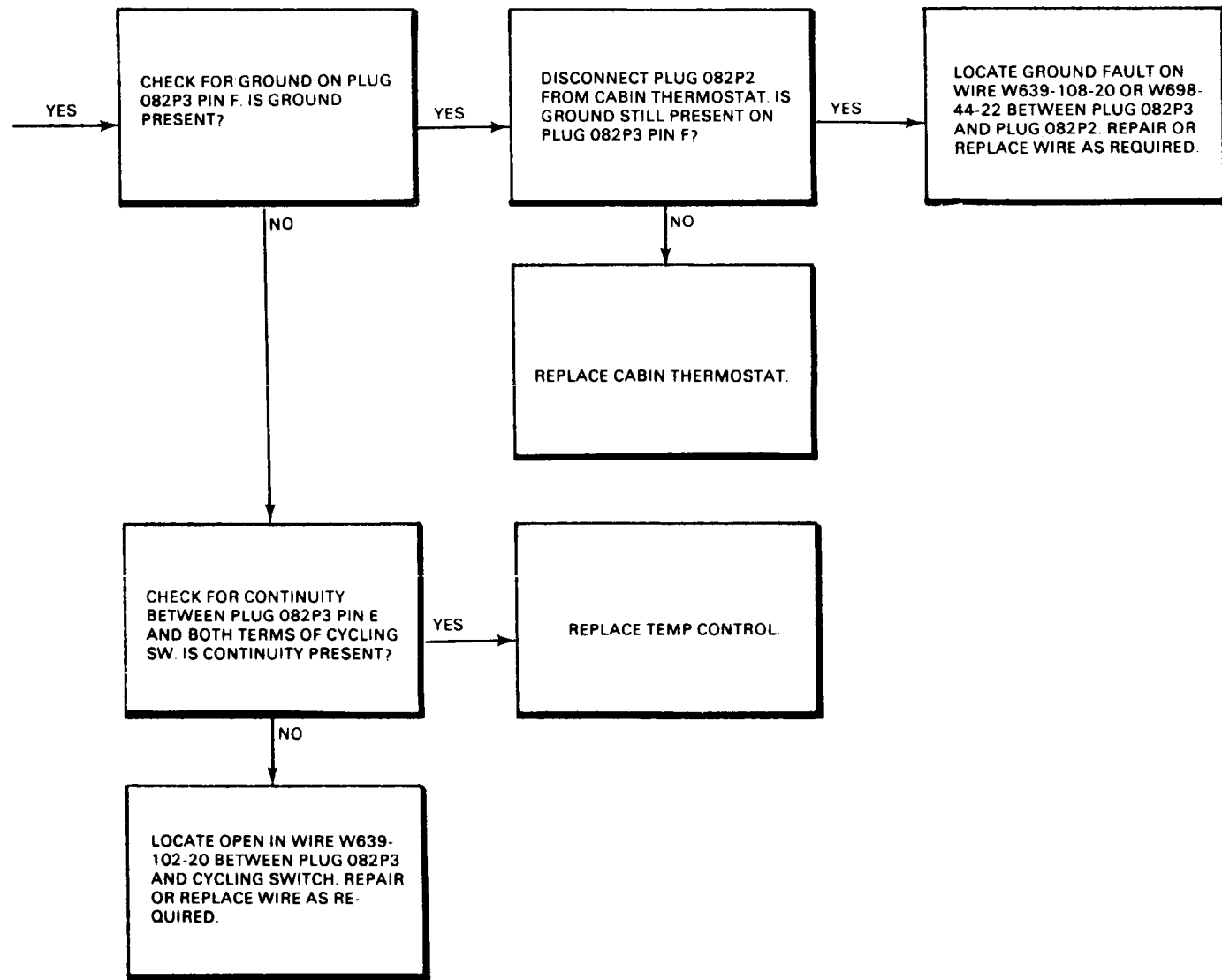

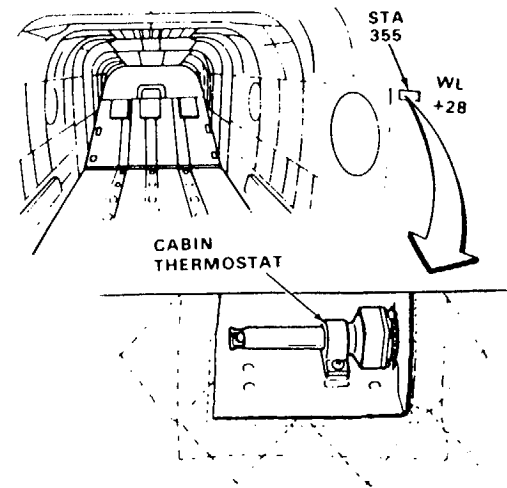

90X54

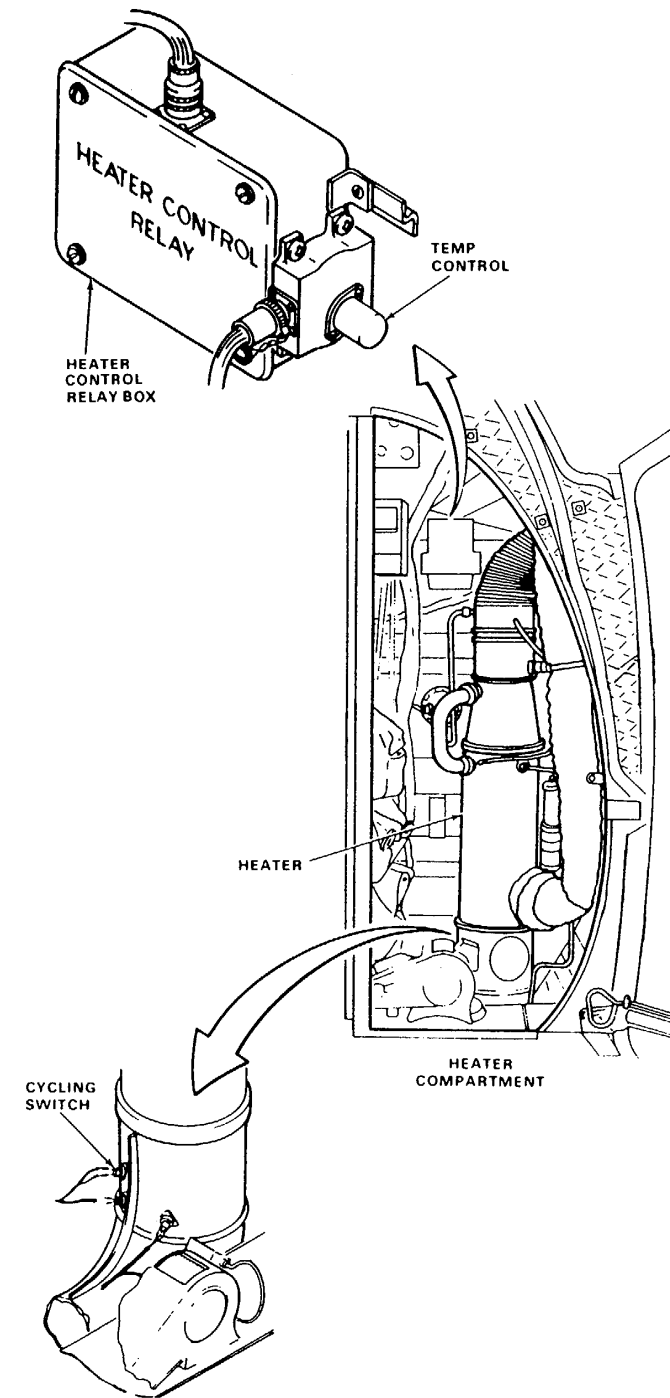

D145-11819-5PA

END OF TASK

13-1.13 HEATER HOT (WITHOUT 74) HTR HOT 74 LIGHT COMES ON

13-1.13

FAULT ISOLATION PROCEDURE

INITIAL SETUP

Applicable Configurations:
All

Tools:
Aircraft Mechanic's Tool Kit,
NSN 5180-00-323-4692
Electrical Repairer's Tool Kit,
NSN 5180-00-323-4915
Multimeter

Materials:
None

Personnel Required:
Medium Helicopter Repairer
Aircraft Electrician

References:
TM 55-1520-240-23
Equipment Condition:
TM 55-1520-240-23:
Battery Connected
Electrical Power On
Hydraulic Power Off
Heater Compartment Acoustic Blanket
Removed

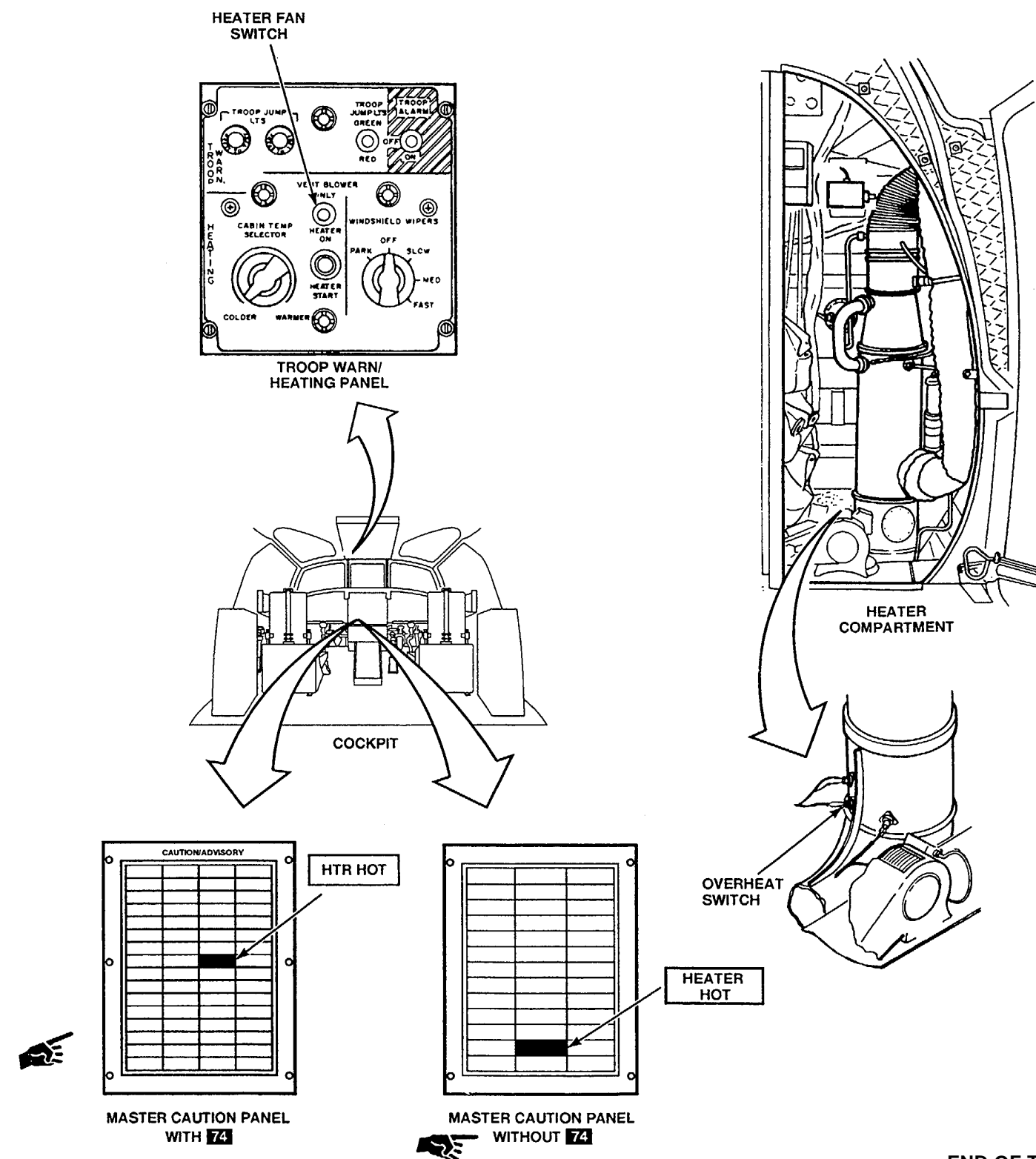
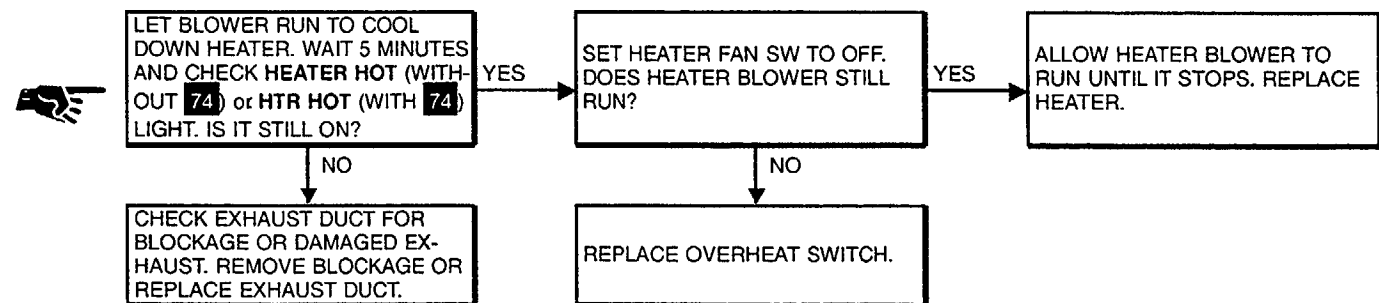

13-1.14 SYSTEM DOES NOT RESPOND TO CHANGES IN CABIN TEMP SELECTOR SETTING

FAULT ISOLATION PROCEDURE

INITIAL SETUP

Applicable Configurations:
All

References:
TM 55-1520-240-23

Tools:
Electrical Repairer's Tool Kit,
NSN 5180-00-323-4915
Multimeter

Equipment Condition:
TM 55-1520-240-23:
Battery Connected
Electrical Power On
Hydraulic Power Off
Heater Compartment Acoustic Blanket
Removed

Personnel Required:
68F10 Aircraft Electrician
68F20 Aircraft Electrician

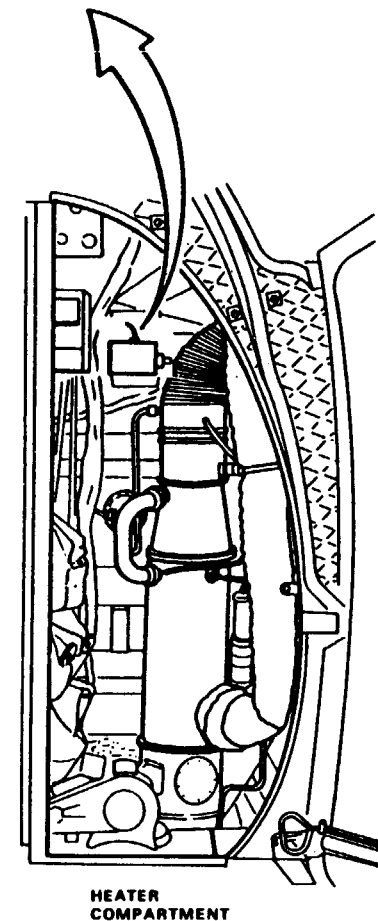
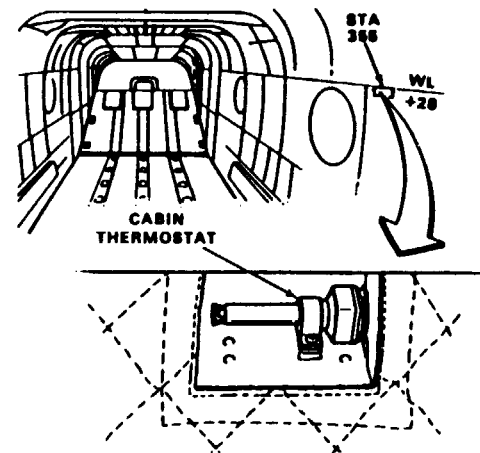
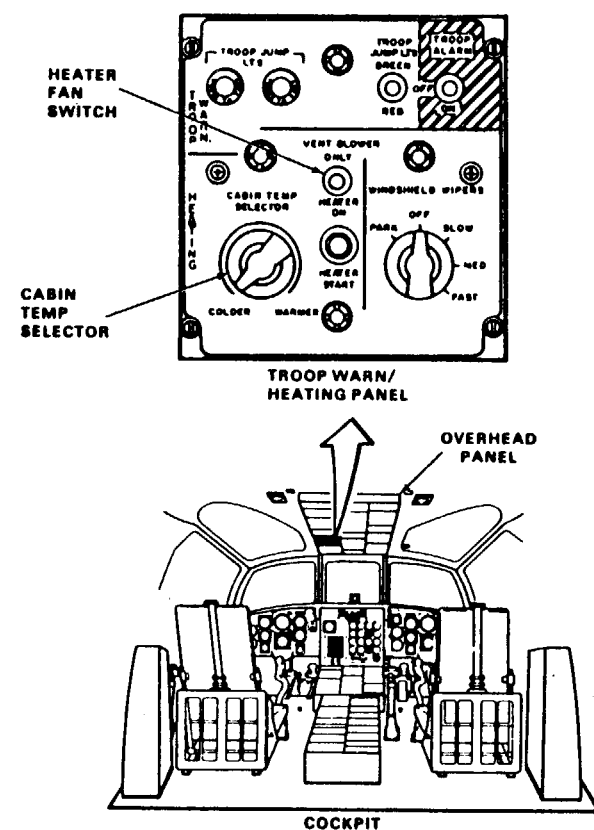
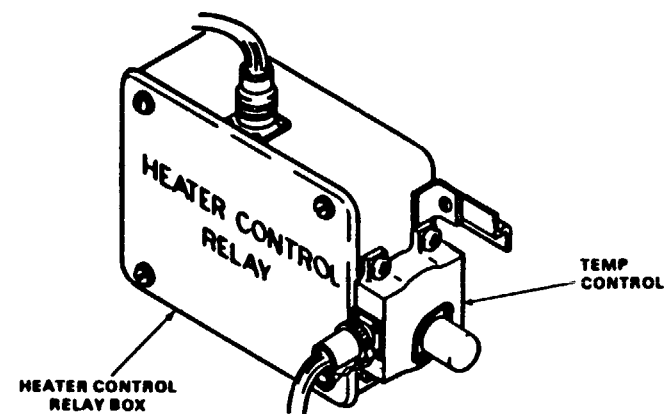

90254

D145-8089-SPA

Page 13-29 is a blank page.

GO TO NEXT PAGE

13-1.14 SYSTEM DOES NOT RESPOND TO CHANGES IN CABIN TEMP SELECTOR SETTING (Continued)

13-1.14

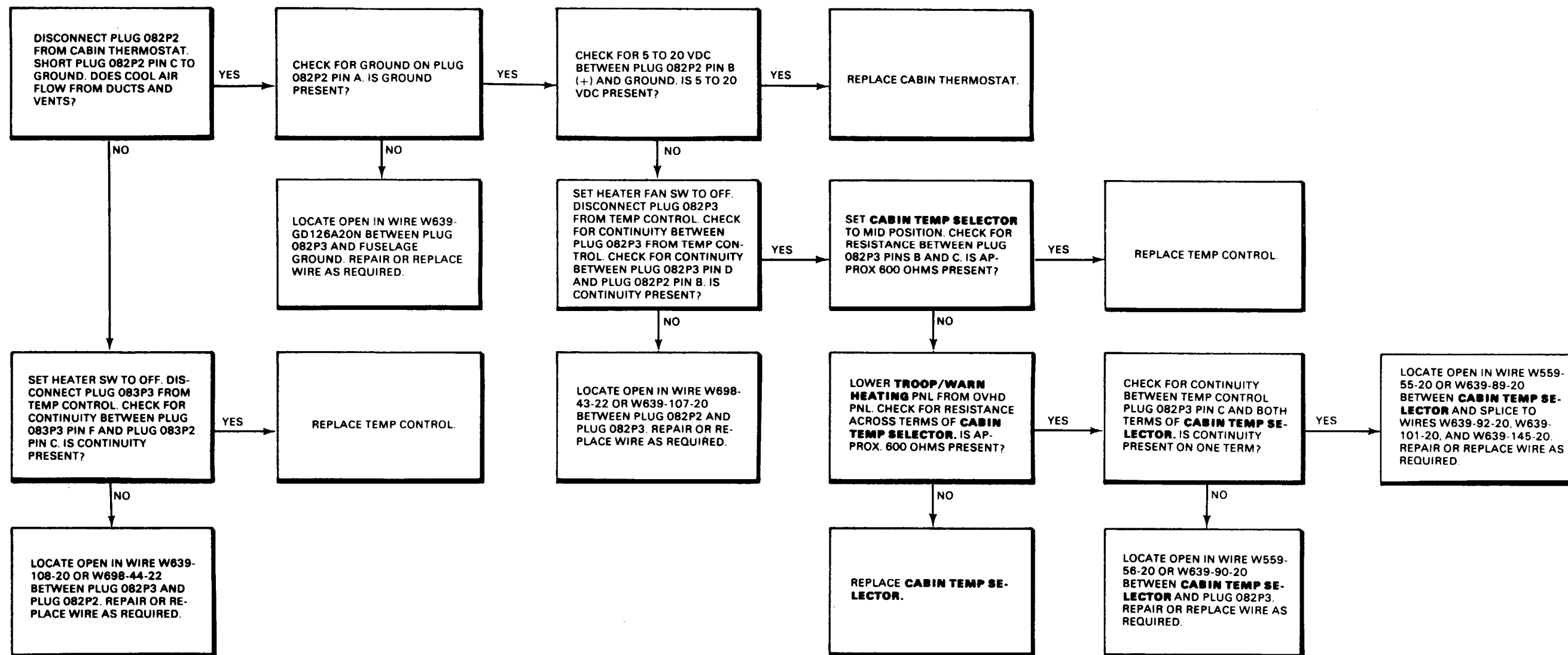

END OF TASK

13-1.15 HEATER FAN STOPS RUNNING IMMEDIATELY AFTER HEATER FAN SWITCH SET TO OFF

FAULT ISOLATION PROCEDURE

INITIAL SETUP

Applicable Configurations:
All

Tools:
Electrical Repairer's Tool Kit,
NSN 5180-00-323-4915
Multi meter

Materials:
None

Personnel Required:
68F20 Aircraft Electrician

References:
TM 55-1520-240-23

Equipment Condition:
TM 55-1520-240-23:
Battery Connected
Electrical Power On
Hydraulic Power Off
Heater Compartment Acoustic Blanket
Removed

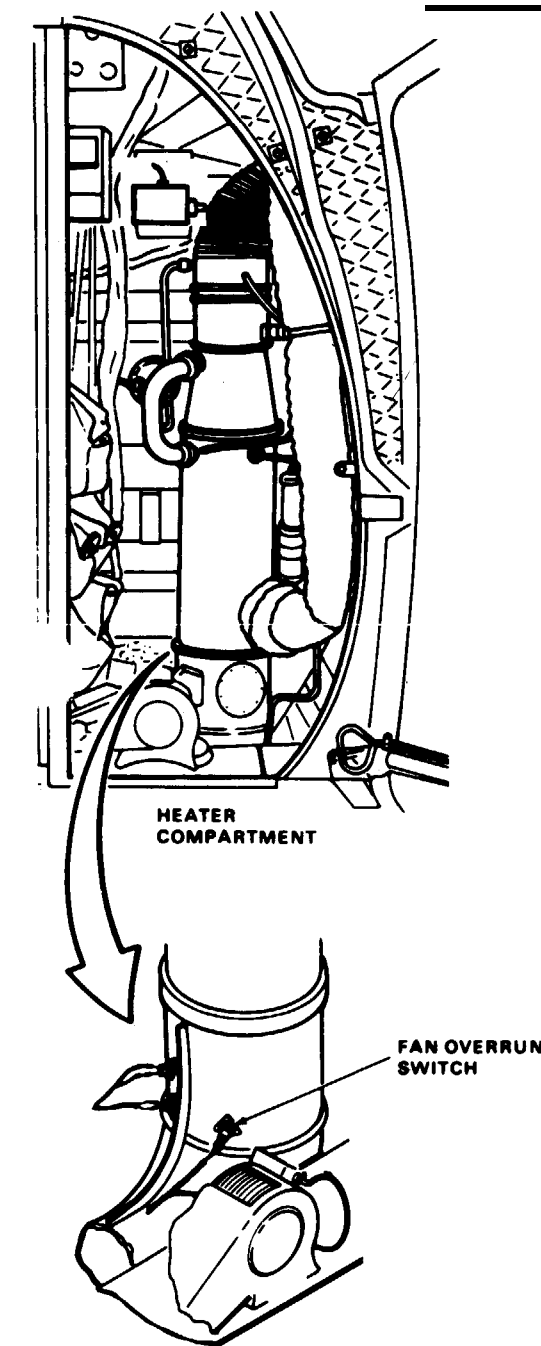
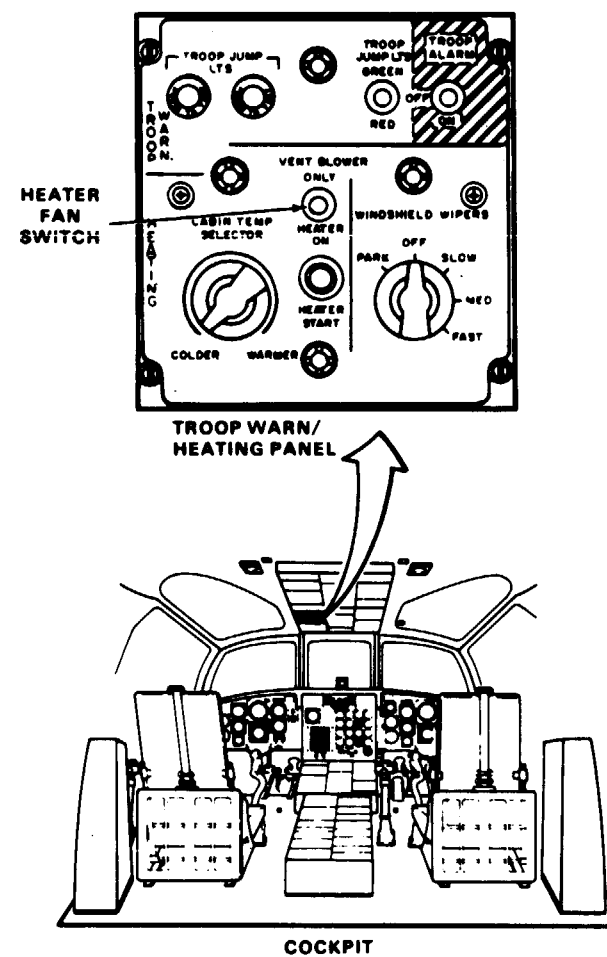
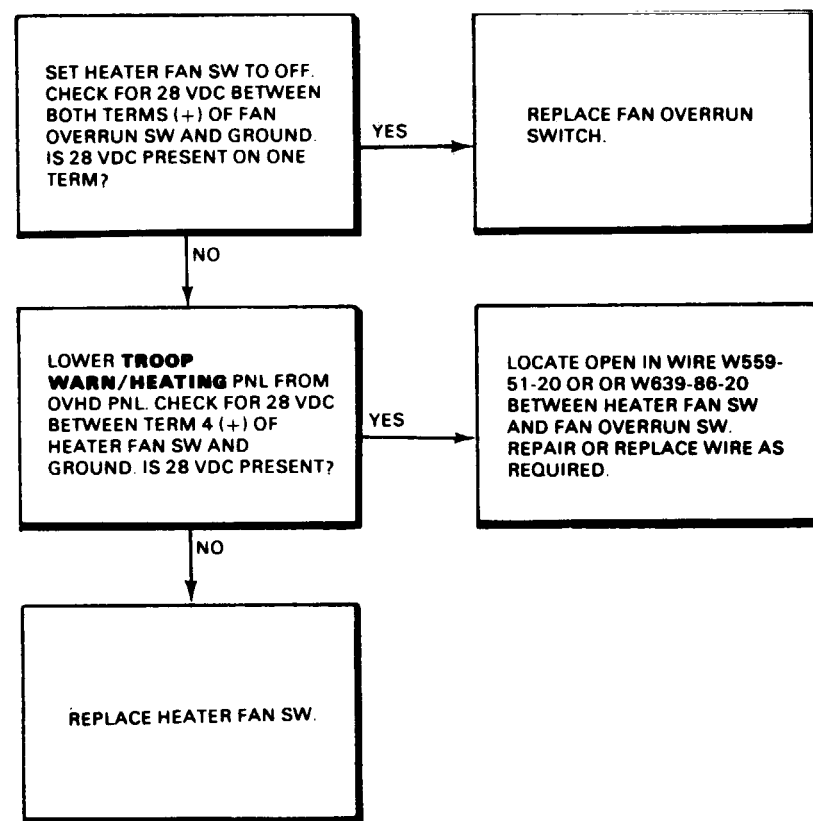

CHAPTER 14

HOIST AND WINCH TROUBLESHOOTING

CHAPTER 14
HOIST AND WINCH TROUBLESHOOTING
CHAPTER OVERVIEW

Chapter 14 contains procedures for Hoist and Winch System troubleshooting. Hoist and winch system failure symptoms are listed below. Included in this Chapter are locations and views of all electrical connectors, receptacles, relays, and ground connections for Hoist and Winch System.

Refer to TM 55-1520-240-23 for required Hoist and Winch maintenance procedures.

SYSTEM	PARA
CARGO/RESCUE WINCH SYSTEM	14-1

FAILURE SYMPTOM LIST

HOIST AND WINCH

SYMPTOM	TASK
CABLE DOES NOT REEL IN WHEN WINCH IS CONTROLLED AT HOIST/CARGO HOOK PANEL	14-1.4
CABLE DOES NOT REEL IN WHEN WINCH IS CONTROLLED BY WINCH GRIP AT STA 95 AUXILIARY PANEL	14-1.4
CABLE DOES NOT REEL IN WHEN WINCH IS CONTROLLED BY WINCH GRIP AT STA 502 RECEPTACLE	14-1.4
CABLE DOES NOT REEL OUT WHEN WINCH IS CONTROLLED AT HOIST/CARGO HOOK PANEL	14-1.4
CABLE DOES NOT REEL OUT WHEN WINCH IS CONTROLLED BY WINCH CONTROL GRIP AT STA 95 AUXILIARY PANEL	14-1.4

SYMPTOM	TASK
CABLE DOES NOT REEL OUT WHEN WINCH IS CONTROLLED BY WINCH GRIP AT HOIST OPERATORS STATION	14-1.4
HOIST CABLE CUTTER CIRCUIT BREAKER DOES NOT STAY CLOSED	14-1.4
HOIST CONT CIRCUIT BREAKER DOES NOT STAY CLOSED	14-1.4
28 VDC NOT MEASURED AT STA 340 CABLE CUTTER RECEPTACLE WHEN HOIST/CARGO HOOK PANEL CABLE CUTTER SWITCH IS SET TO ON	14-1.4
28 VDC NOT MEASURED AT STA 340 CABLE CUTTER RECEPTACLE WHEN WINCH GRIP CABLE CUTTER SWITCH PRESSED AT HOIST OPERATOR OR AUXILIARY PANEL	14-1.4

HOIST SYSTEM ELECTRICAL COMPONENT LOCATION AND CONFIGURATION LIST

REF DESIG	PART NUMBER	TYPE	MATE WITH/LOCATION	STATION LOCATION			REF DESIG	PART NUMBER	TYPE	MATE WITH/LOCATION	STATION LOCATION		
				FS	WL	BL					FS	WL	BL
GD034		150	FWD AND ABOVE OVHD PNL	61	40	10L	300J1	M83723-74A2041N	40	NO. 1 PDP			
GD 194		151	HEATER COMPARTMENT	120	40	18R	300P1	M83723-75A2041N	40	NO. 1 PDP			
TB 17			WALKWAY - UNDERFLOOR	105	-30	18R	300J4	M83723-74A2461N	43	NO. 1PDP			
TB 27			RH CABIN	330	50	50R	300P4	M83723-75A2461N	43	NO. 1 PDP			
TB 36			OVERHEAD PANEL - COCKPIT	80	40	12R	300J19	M83723-73A2041N	40	OVERHEAD PANEL -COCKPIT			
TB 37			OVERHEAD PANEL - COCKPIT	80	40	12L	300P19	M83723-76A2041N	40	OVERHEAD PANEL -COCKPIT			
132P1	MS3476W10-6S	15	HOIST WINCH MOTOR	120	-25	30R	300J20	M83723-74A2461N	43	OVERHEAD PANEL -COCKPIT			
132P2	M83723-95A1005N	30	HOIST CONTROL VALVE	120	25	18R	300P20	M83723-75A2461N	43	OVERHEAD PANEL -COCKPIT			
132P3	M83723-95A0803N	29	BRAKE REL SOL	120	35	18R	300J22	M83723-73A20416	40	OVERHEAD PANEL -COCKPIT			
132P4	MS3456W10SL-3S	45	CABLE CUTTER, RECIP	340	50	0	300P22	M83723-76A20416	40	OVERHEAD PANEL -COCKPIT			
132P5	MS3456W10S-2S	44	CABLE CUTTER SOL	340	50	0	300J47	M83723-74A2461N	43	HEATER COMPARTMENT -OVHD	105	40	30R
132P6	MS3476W14-19P	21	HOIST, OPR PNL	340	50	50R	300P47	M83723-75A2461N	43	HEATER COMPARTMENT -OVHD	105	40	30R
132P7	MS3476W14-19S	21	HOIST OPR CONT GRIP	340	50	50R	300J48	M83723-74A2461N	43	ELECTRONICS COMPARTMENT OVHD	120	40	20L
132J8	MS3450W10SL-3P	45	CABLE CUTTER STOW RECIP	95	-10	25R	300P48	M83723-75A2461N	43	ELECTRONICS COMPARTMENT OVHD	120	40	20L
132J9	MS3470W14-19S	21	MATES WITH 132P6	110	-10	25R	300J52	M83723-74A2255N	42	AFT CROWN	460	45	30L
132J10	MS3450W10SL-3P	45	RECEPT-CABLE CUTTER	340	50	0	300P52	M83723-75A2255N	42	AFT CROWN	460	45	30L
132J11	MS3470W14-19S	21	132P6 AT HOIST OPR PNL	340	40	50R							
132J12	MS3470W14-19S	21	132P6 AT AFT HOIST OPR	502	-20	50L							
134P1	MS3476W14-19S	21	OVERHEAD PANEL - COCKPIT	80	40	10L							

HOIST AND WINCH SYSTEM ELECTRICAL COMPONENT
LOCATION AND CONFIGURATION LIST (Continued)

RECEPTACLE

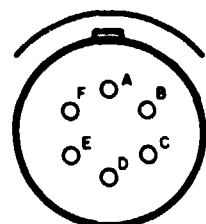

15

PLUG

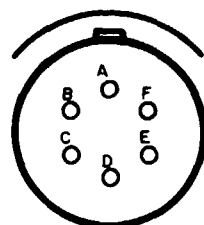

15

RECEPTACLE

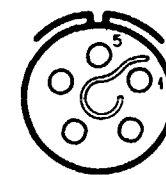

30

PLUG

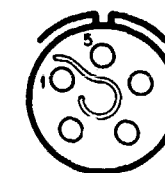

30

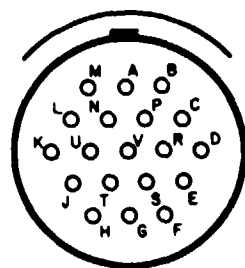

21

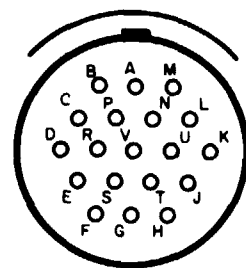

21

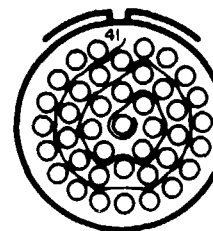

40

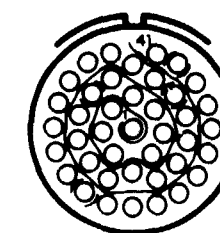

40



29



29

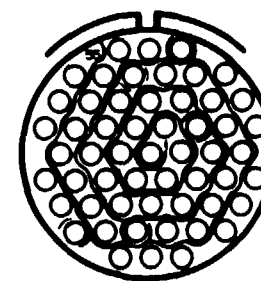

42

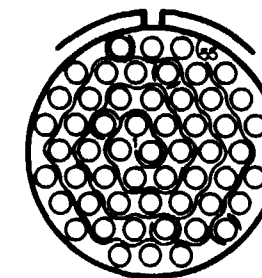

42

HOIST AND WINCH SYSTEM ELECTRICAL COMPONENT
LOCATION AND CONFIGURATION LIST (Continued)

RECEPTACLE

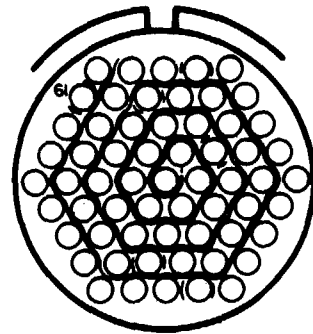

43



44



45

PLUG

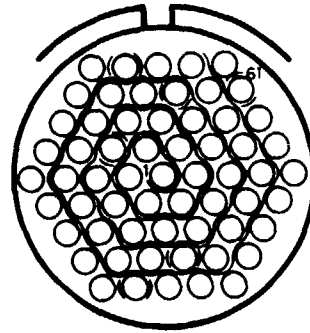

43



44

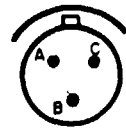

45

GND MODULE

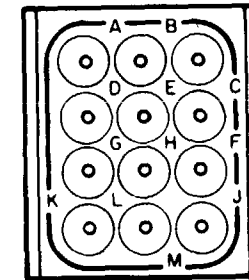

150

GND STUD



151

14-1 CARGO/RESCUE WINCH SYSTEM

14-1 CARGO/RESCUE WINCH SYSTEM

14-1.1 CARGO/RESCUE WINCH SYSTEM SCHEMATIC

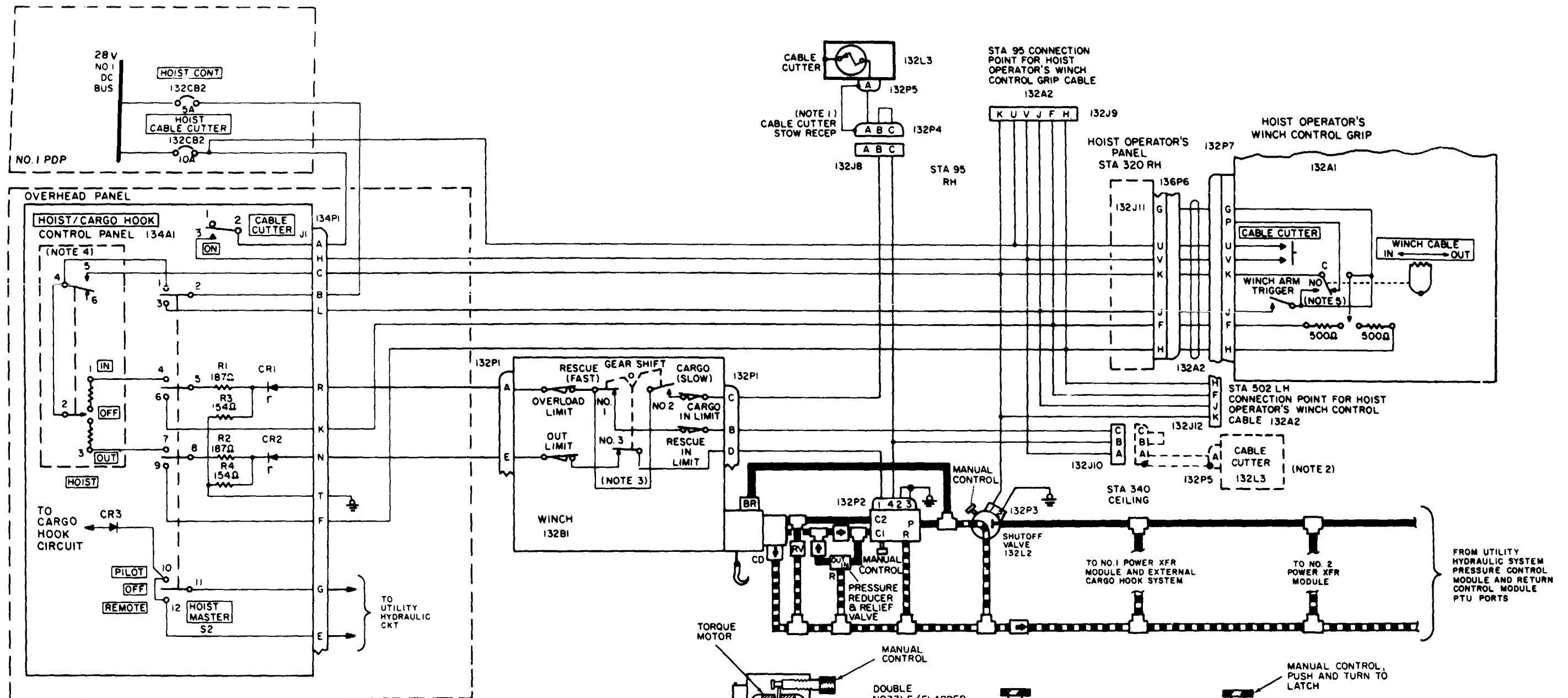

NOTES

- 1 CABLE CUTTER CONNECTED THIS LOCATION FOR CARGO HANDLING OPERATION
- 2 CABLE CUTTER CONNECTED THIS LOCATION FOR RESCUE HOIST OPERATION
- 3 SWITCH NO 3 IS OPENED WHEN SWITCHES NO 1 AND NO 2 ARE OPEN. SWITCH NO 3 IS CLOSED WHEN SWITCH NO 1 OR NO 2 IS CLOSED. THIS PREVENTS WINCH OPERATION WHEN GEARS ARE NOT ENGAGED

- 4 CONTACTS 4 AND 5 CLOSE WHEN SWITCH MOVED OFF CENTER POSITION
- 5 N.O. CONTACTS CLOSE WHEN SWITCH MOVED OFF CENTER POSITION
- 6 INDICATES EQUIPMENT MARKING
- 7 HYDRAULIC CODE
 PRESSURE
 RETURN

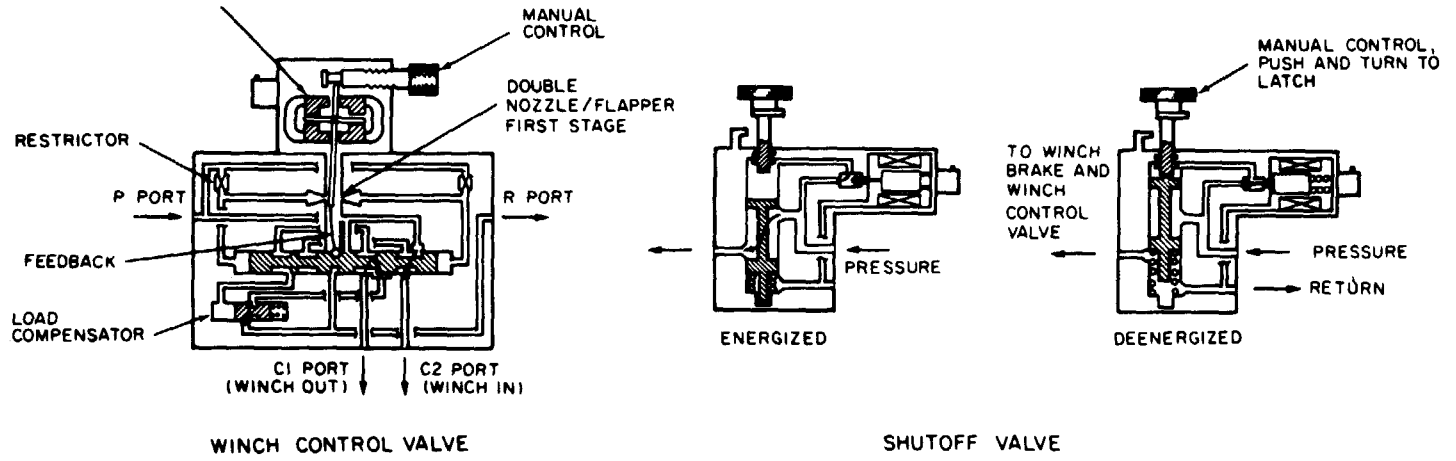

14-1.2 CARGO/RESCUE WINCH SYSTEM WIRING DIAGRAM

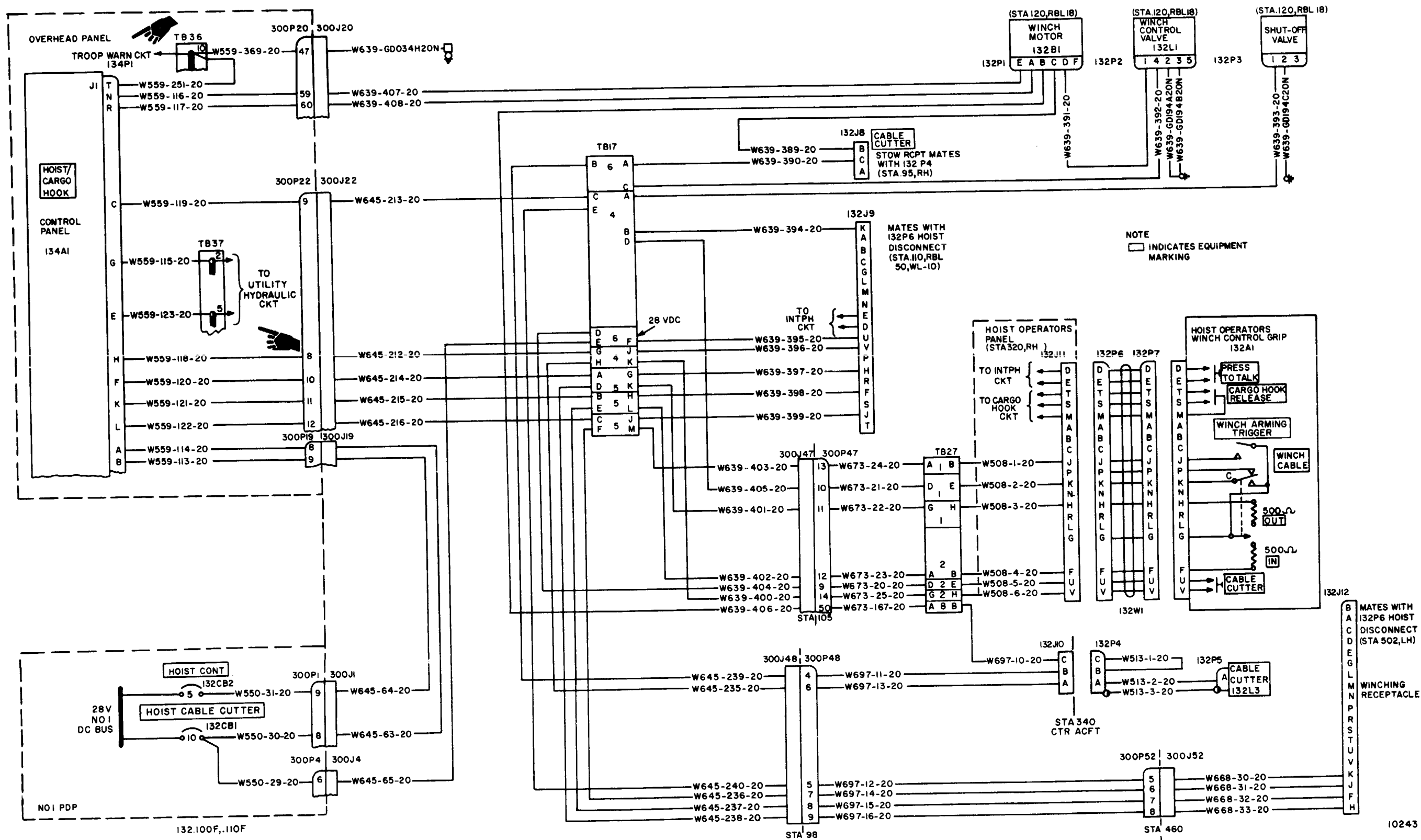

14-1.3 CARGO/RESCUE WINCH SYSTEM VISUAL CHECK

INITIAL SETUP

Applicable Configurations:
All

Tools:
Aircraft Mechanic's Tool Kit,
NSN 5180-00-323-4692

Materials:
None

Personnel Required:
67U10 Medium Helicopter Repairer

References:
TM 55-1520-240-23

Equipment Condition:
TM 55-1520-240-23:
Battery Disconnected
Electrical Power Off
Hydraulic Power Off
Heater Compartment Acoustic
Blanket Removed
Cable Cutter Inspected

TASK	RESULT
1. Check shutoff valve (1).	If valve (1) is loose or damaged, tighten or replace it as required. If hydraulic tubes to valve are loose or damaged, tighten or replace them as required. If electrical connector or wires to valve are damaged, repair or replace as required.
2. Check winch control valve (2).	If valve (2) is loose or damaged, tighten or replace it as required. If hydraulic tubes to valve are loose or damaged, tighten or replace them as required. If electrical connector or wires to valve are damaged, repair or replace as required.
3. Check hydraulic tubes and components between winch control valve (2) and winch (3).	If any hydraulic tube or component is loose or damaged, repair or replace as required.
4. Check winch (3).	If winch (3) is loose or damaged, tighten or replace it. If brake (4) is loose or damaged, tighten or replace it as required. If winch motor (5) is loose or damaged, tighten or replace it as required. If connector or wires to winch are damaged repair or replace as required.

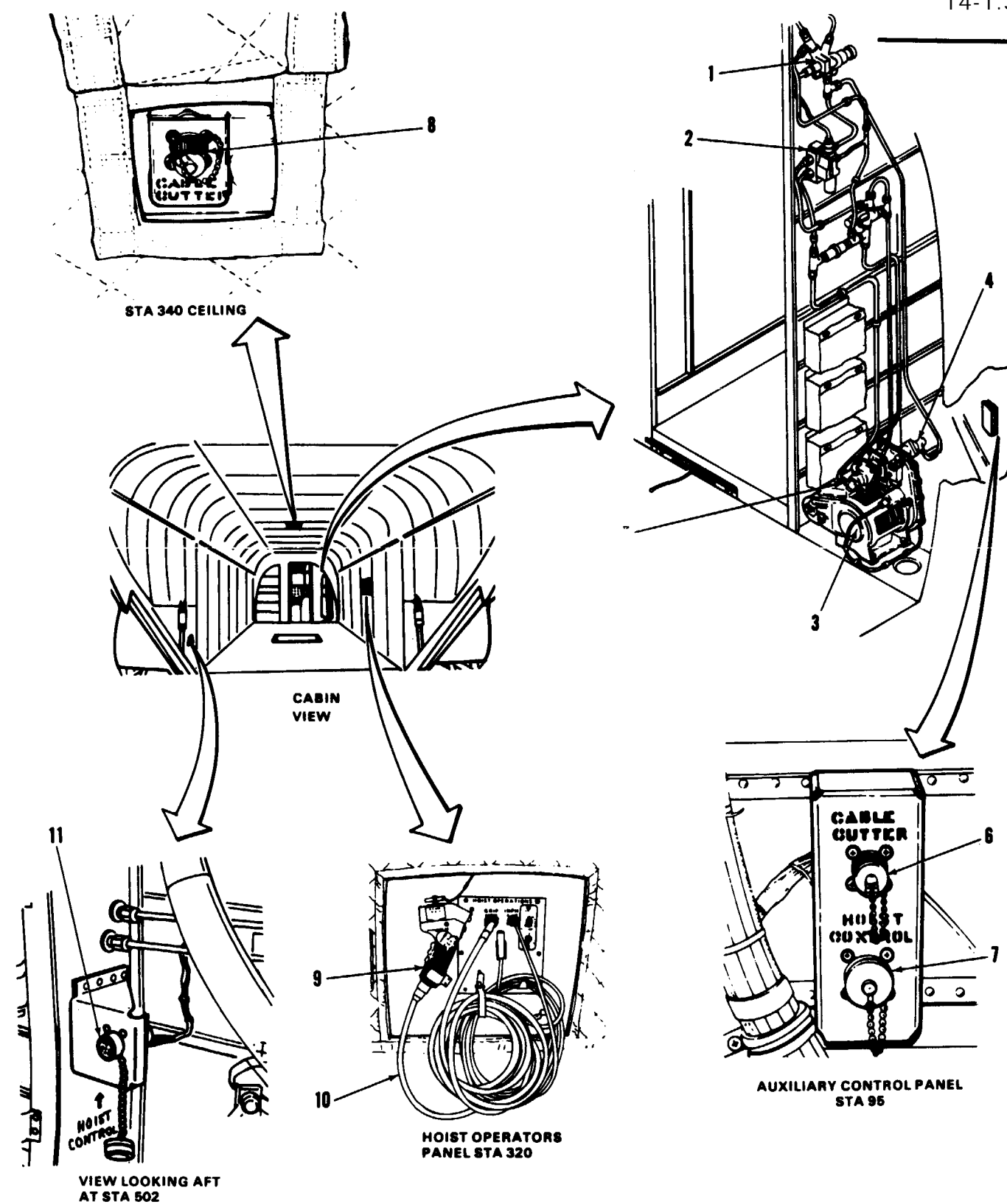

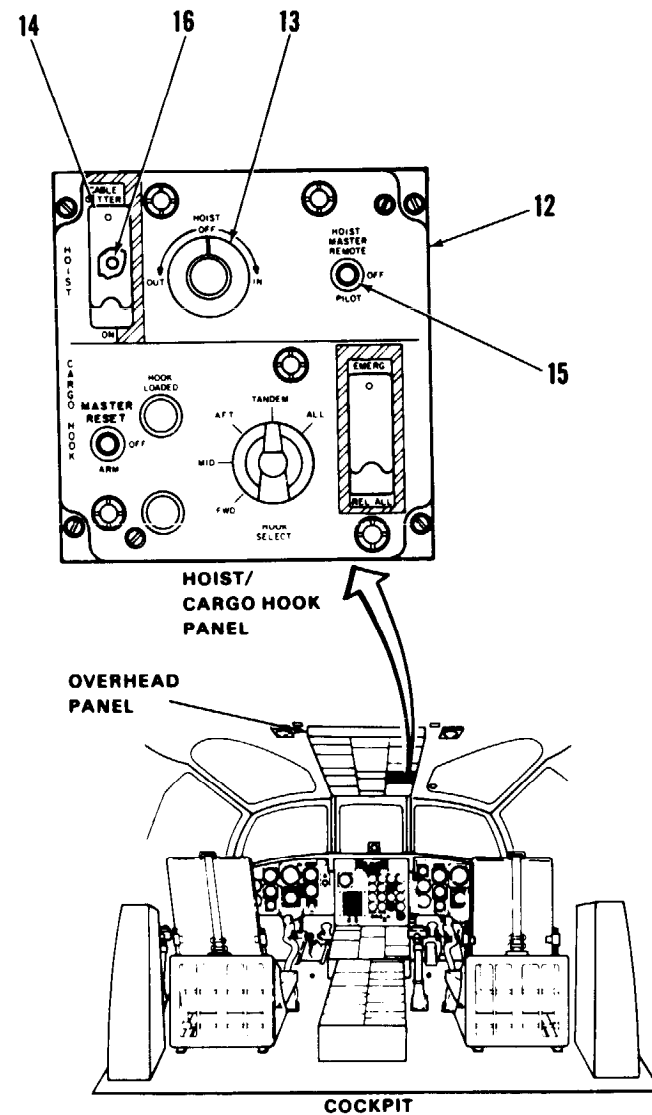

TASK	RESULT
5. Check CABLE CUTTER and HOIST CONTROL receptacles (6 and 7).	If either receptacle or wiring to receptacle (6 or 7) is damaged, repair or replace as required,
6. Pull down cover and check CABLE CUTTER receptacle (8).	If receptacle (8) is damaged; replace it.
7. Check winch operator's grip (9) and cable (10).	If grip (9) is cracked or cable (10) is cut exposing wires, replace it.
8. Check HOIST CONTROL receptacle (11).	If receptacle (11) is damaged, replace it. If receptacle dust cover is damaged or missing, replace it,
9. Check HOIST/CARGO HOOK panel (12).	If knob (13) is loose or damaged, tighten or replace as required. If switchguard (14) is loose or damaged, tighten or replace as required. If switch (15 or 16) is loose or damaged, replace HOIST/CARGO HOOK panel (12).

FOLLOW-ON MAINTENANCE:

None

D145-7105-SPA

END OF TASK

14-1.4 CARGO/RESCUE WINCH SYSTEM OPERATIONAL CHECK

INITIAL SETUP

Applicable Configurations:
All

Tools:
Aircraft Mechanic's Tool Kit,
NSN 5180-00-323-4692
Multi meter
Asbestos Gloves (E187)
Stopwatch
Load, 600 pounds
Load, 3100-3300 pounds

Materials:
Lockwire (E228)

Personnel Required:
68F10 Aircraft Electrician
67U10 Medium Helicopter Repairer
67U20 Medium Helicopter Repairer

References:

TM 55-1520-240-23
TM 55-1520-240-10

Equipment Condition:

TM 55-1520-240-23:
Battery Connected
Electrical Power On
Hydraulic Power On
Center Cargo Hook
Removed
Visual Check of Cargo/Rescue Winch System
Performed (Task 14-1.3)

General Safety Instructions:

WARNING

Wear gloves when handling wire rope (cable). Otherwise, injury to hands can result.

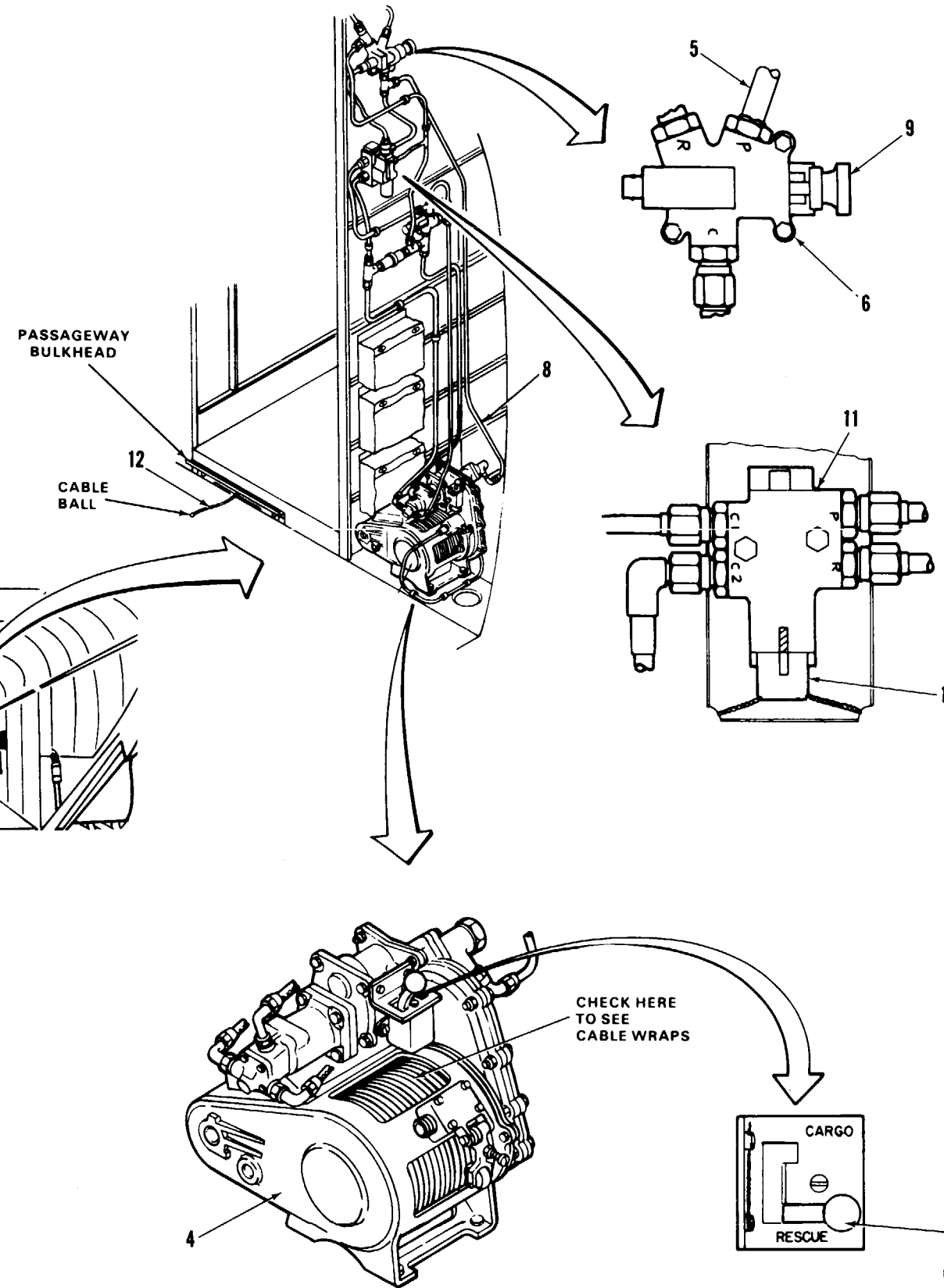
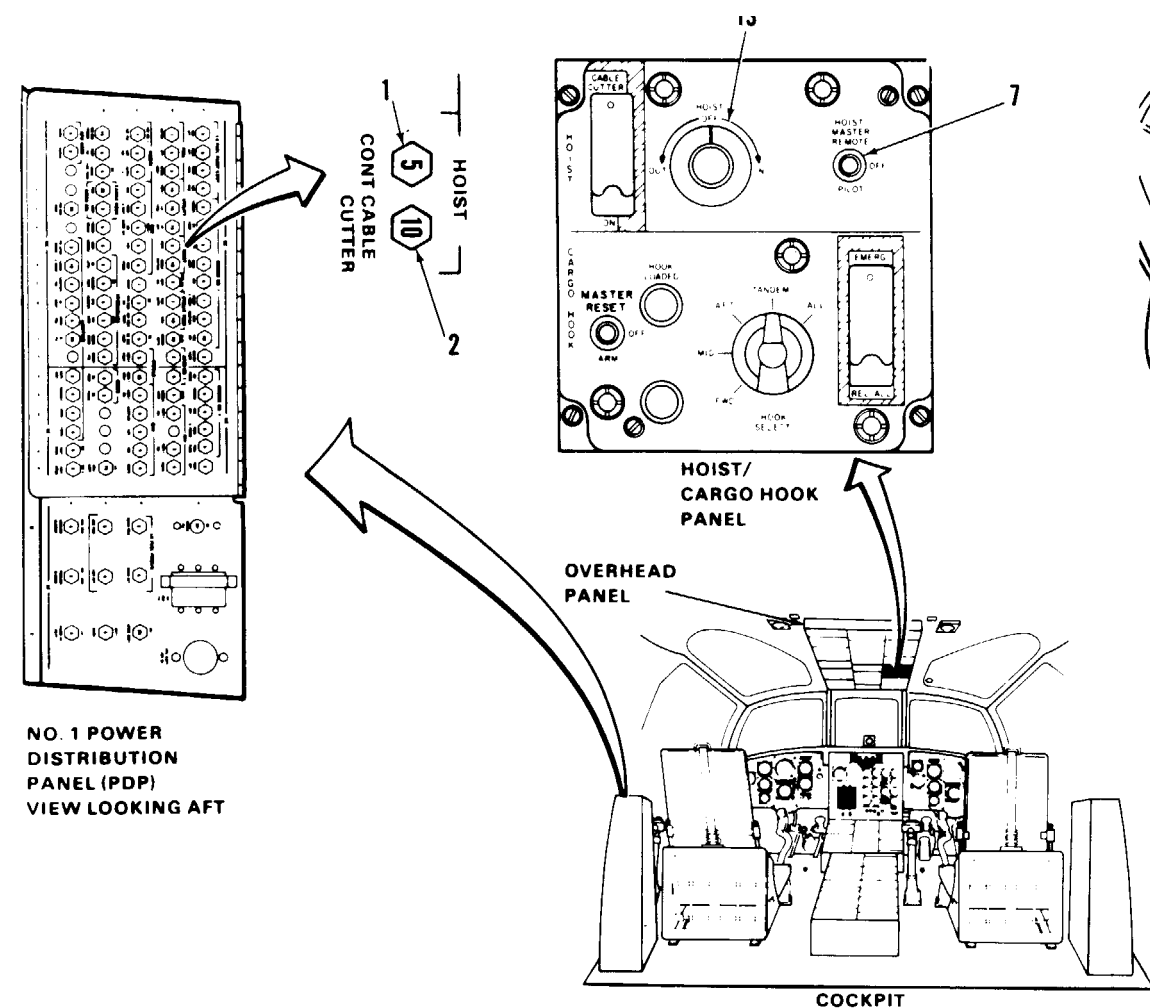

D145-7106-SPA

GO TO NEXT PAGE

14-1.4 CARGO/RESCUE WINCH SYSTEM OPERATIONAL CHECK
(Continued)

14-1.4

TASK	RESULT
NOTE	
<p>Keep tension on wire rope (cable) when reeling cable. Cable will reel evenly and will not snarl.</p>	
1. Check that HOIST CONT and HOIST CABLE CUTTER circuit breakers (1 and 2) are closed.	If either circuit breaker (1 or 2) is open, close it. If HOIST CONT circuit breaker (1) opens again, go to task 14-1.5. If HOIST CABLE CUTTER circuit breaker (2) opens again, go to task 14-1.6.
2. Check that winch shift lever (3) is set to RESCUE.	If lever (3) not at RESCUE, set it to RESCUE. If lever can not be set to RESCUE, replace winch (4),
3. Hold pressure line (5) to shutoff valve (6). Set HOIST MASTER switch (7) to PILOT.	Pressure surge should be felt on pressure line (5). If not, go to task 7-2.4.
4. Hold pressure line (8) to brake on winch (4). Push in and turn pushbutton (9) on shutoff valve (6). Release pushbutton.	Pressure surge should be felt on pressure line (8). If not, replace shutoff valve (6). Push button (9) shall remain locked when released. If it comes out, replace shutoff valve (6).
5. Remove lockwire from knob (10) on winch control valve (11).	
6. Turn knob (10) in one direction. Reel out enough wire rope (cable) (12) to rig. Release knob. Have helper keep slight drag on cable. Helper must wear gloves.	Cable (12) shall reel off winch (4), if it does not, turn knob (10) in opposite direction. If cable still does not reel off winch, replace winch,
7. Rig winch (4) for rescue mode (TM 56-1620-240-10).	
8. Turn and release pushbutton (9).	Pushbutton (9) shall come out. If it does not, replace shutoff valve (6).
9. Turn knob (10) in any direction. Release knob.	Winch (4) shall not operate. If it does, replace shutoff valve (6).
10. Turn HOIST control (13) to OUT. Release control to OFF when cable (12) stops reeling out.	Winch (4) shall reel out cable (12) within <u>90 seconds</u> and stop when <u>2-1/2 wraps</u> of first layer of cable remain on winch drum. If winch does not reel out cable, go to task 14-1.7. If cable takes longer than <u>90 seconds</u> to reel out, replace winch. If winch does not stop when <u>2-1/2 wraps</u> remain on drum, adjust winch out-limit switch, TM 55-1520-240-23. If switch can not be adjusted, replace winch.
NOTE	
<p>With cable reeled out, an inspection for broken strands or definite bends can be performed.</p>	

TASK	RESULT
CAUTION	
<p>Do not allow cable end to reel in and jam in a pulley. Damage to winch, pulley, or airframe can occur.</p>	
11. Turn HOIST control (13) to IN. Release control to OFF when cable (12) stops reeling in. Have helper keep slight drag on cable. Helper must wear gloves.	Winch (4) shall reel in cable (12) within <u>90 seconds</u> and stop automatically when <u>26 to 26-1/2 feet</u> of cable remain extended. Cable length is measured from sta 120 passageway bulkhead to cable ball end. If winch does not reel in cable, go to task 14-1.8. If cable takes longer than <u>90 seconds</u> to reel in, or cable binds or spools unevenly, replace winch. If winch stops too soon or late, (<u>26 - 26-1/2 feet</u> of cable not reeled), adjust rescue in-limit switch, TM 55-1520-240-23. If switch can not be adjusted, replace winch,

GO TO NEXT PAGE

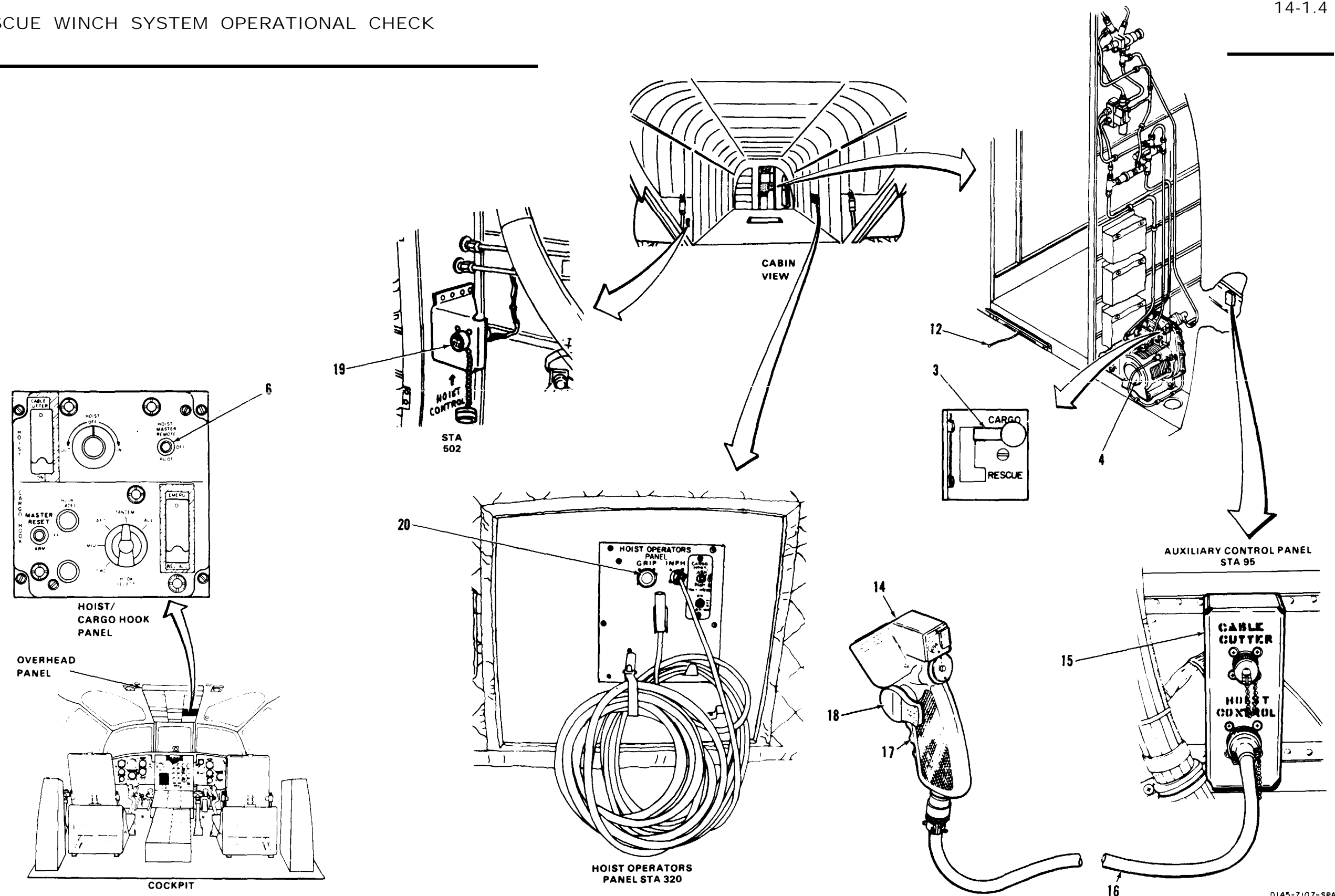

14-1.4 CARGO/RESCUE WINCH SYSTEM OPERATIONAL CHECK
(Continued)

14-1.4

TASK	RESULT
12. Set HOIST MASTER switch (7) to REMOTE.	
13. Connect winch control grip (14) to auxiliary panel (15) with cable (16).	
14. On winch control grip (14), press and hold WINCH ARMING TRIGGER switch (17) and set WINCH CABLE control (18) to OUT. Reel out enough cable to hook up a load in rescue mode (TM 55-1520-240-10). Then release controls (17 and 18).	Cable (12) shall reel off winch. If it does not, go to task 14-1.9.
15. Connect 600-pound load to cable hook.	
16. On winch control grip (14), press and hold WINCH ARMING TRIGGER switch (17) and set WINCH CABLE control (18) to IN. Release controls (17 and 18) after load clears ground.	Winch (4) shall raise load and hold it steady, If winch does not raise load, go to task 14-1.10. If winch sounded like it was beginning to operate but stopped, replace winch. If load creeps down after grip controls released, replace winch.
17. On winch control grip (14), press and hold WINCH ARMING TRIGGER switch (17) and set WINCH CABLE control (18) to OUT. Release controls (17 and 18) after tension is off cable. Disconnect 600-pound load.	
18. On winch control grip (14), press and hold WINCH ARMING TRIGGER switch (17) and set WINCH CABLE control (18) to OUT. Reel out enough cable to hookup an external load. Then release controls (17 and 18).	
19. Set winch shift lever (3) to CARGO.	
20. Rig winch (4) for cargo mode (TM 55-1520-240-10).	
21. Deleted.	
22. Connect winch control grip (14) to sta 502 HOIST CONTROL receptacle (19) with cable (16).	

TASK	RESULT
WARNING	
Cable failure during loading operations will result in cable whiplash within the cabin. This may result in personnel injury. Stand aft and to one side of load to avoid whiplash exposure.	
23. On winch control grip (14), press and hold WINCH ARMING TRIGGER switch (17) and set WINCH CABLE control (18) to IN.	Winch (4) shall reel in cable (12) and stop when second layer of cable starts on cable drum. If winch does not reel in cable, go to task 14-1.11. If winch continues to operate, release controls (17 and 18). Adjust overload limit switch. If switch is adjusted, repeat steps 18 thru 23. If winch still does not stop when second layer of cable wraps begins, replace winch.
24. On winch control grip (14), press and hold WINCH ARMING TRIGGER switch (17) and set WINCH CABLE control (18) to OUT. Release controls (17 and 18) after tension is off cable (12). Disconnect load from cable hook.	Cable (12) shall reel off winch (4), If winch does not operate, locate open in wire W668-33-20, W697-16-20, or W645-238-20 between receptacle 132J12 and TB17. Repair or replace wire as required.
25. Connect winch control grip (14) to HOIST OPERATOR'S panel receptacle (20) with cable (16).	
NOTE	
If necessary, reel in several feet of cable to perform following step.	
26. On winch control grip (14), press and hold WINCH ARMING TRIGGER switch (17) and set WINCH CABLE control (18) to OUT. Release controls (17 and 18) when several feet of cable (12) are reeled out. Have helper keep slight tension on cable. Helper must wear gloves.	Cable (12) shall reel off winch (4). If it does not, go to task 14-1.12.

GO TO NEXT PAGE

14-1.4 CARGO/RESCUE WINCH SYSTEM OPERATIONAL CHECK
(Continued)

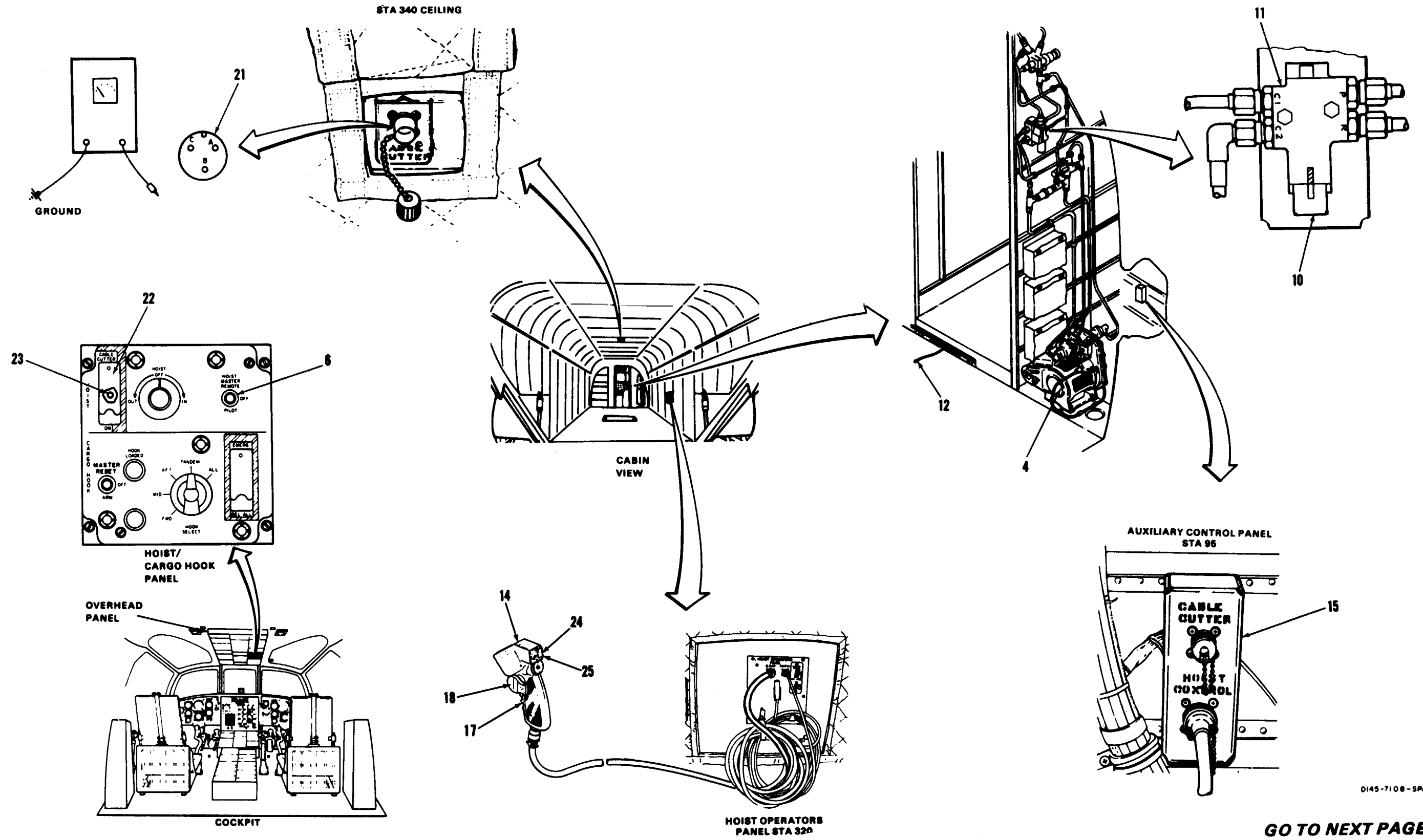

D145-7108-SPA

GO TO NEXT PAGE

14-1.4 CARGO/RESCUE WINCH SYSTEM OPERATIONAL CHECK
(Continued)

14-1.4

TASK	RESULT
<p>CAUTION</p> <p>Do not allow cable end to reel in and jam in a pulley. Damage to winch, pulley, or airframe can occur.</p>	
<p>27. On winch control grip (14), press and hold WINCH ARMING TRIGGER switch (17) and set WINCH CABLE control (18) to IN.</p>	<p>Winch (4) shall reel in cable (12) and stop when 12 to 20 inches of cable remain out. If winch does not operate, locate open in wire W508-4-20, W673-23-20, or W639-402-20 between receptacle 132J11 and TB17. Repair or replace wire as required.</p> <p>If more or less than 12 to 20 inches of cable is out when winch stops, adjust cargo in-lmt switch, If switch is adjusted, repeat steps 18 thru 27. If more or less than 12 to 20 inches of cable is out, replace winch.</p>
<p>28. Connect multimeter, set to measure 28 <u>vdc</u> between pin A (+) of CABLE CUTTER receptacle (21) and ground.</p>	
<p>29. Lift switch guard (22) and set and hold CABLE CUTTER switch (23) to ON.</p>	<p>Multimeter shall indicate 28vdc. If it does not , go to task 14-1.13.</p>
<p>3.0 Release CABLE CUTTER switch (23) and close swltchguard (22).</p>	
<p>31. On winch control grip (14), lift switch guard (24) and press and hold CABLE CUTTER switch (25).</p>	<p>Multimeter shall indicate 28vdc. If it does not, go to task 14-1.14.</p>
<p>32. Release CABLE CUTTER switch (25) and close swltchguard (24).</p>	
<p>33. Repeat steps 31 and 32 with winch control (14) connected to auxiliary panel (15) with cable (16). Then disconnect multimeter and proceed to step 34.</p>	
<p>34. Set HOIST MASTER switch (6) to OFF.</p>	
<p>35. Check that index on control valve knob (10) aligns with stripe on valve body. Lockwire knob to structure, Use lockwire (E228).</p>	<p>Align stripe if required</p>

FOLLOW-ON MAINTENANCE:

- TM 55-1520-240-23
- Battery disconnected
 - Hydraulic power off
 - Electrical power off
 - Disconnect and stow winch control grip
 - Disconnect and stow cable cutter.
 - Install heater compartment acoustic blanket
 - Install center cargo hook.

END OF TASK

14-1.5 HOIST CONT CIRCUIT BREAKER DOES NOT STAY CLOSED

FAULT ISOLATION PROCEDURE

INITIAL SETUP

Applicable Configurations:
All

Tools:
Electrical Repairer's Tool Kit,
NSN 5180-00-323-4915
Multi meter

Materials:
None

Personnel Required:
68F10 Aircraft Electrician
68F20 Aircraft Electrician

References:
TM 55-1520-240-23

Equipment Condition:
TM 55-1520-240-23:
Battery Disconnected
Electrical Power Off
Hydraulic Power Off

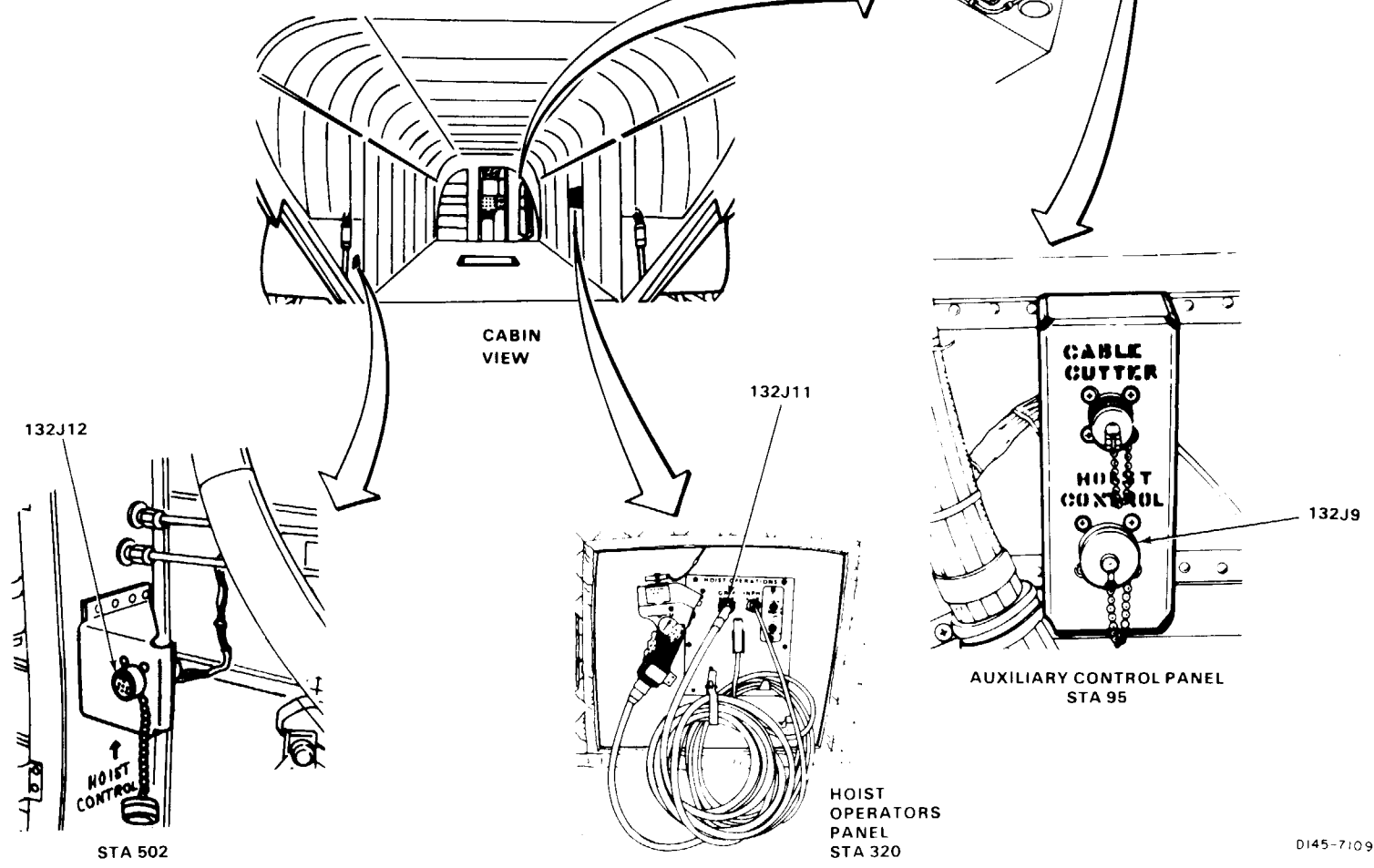
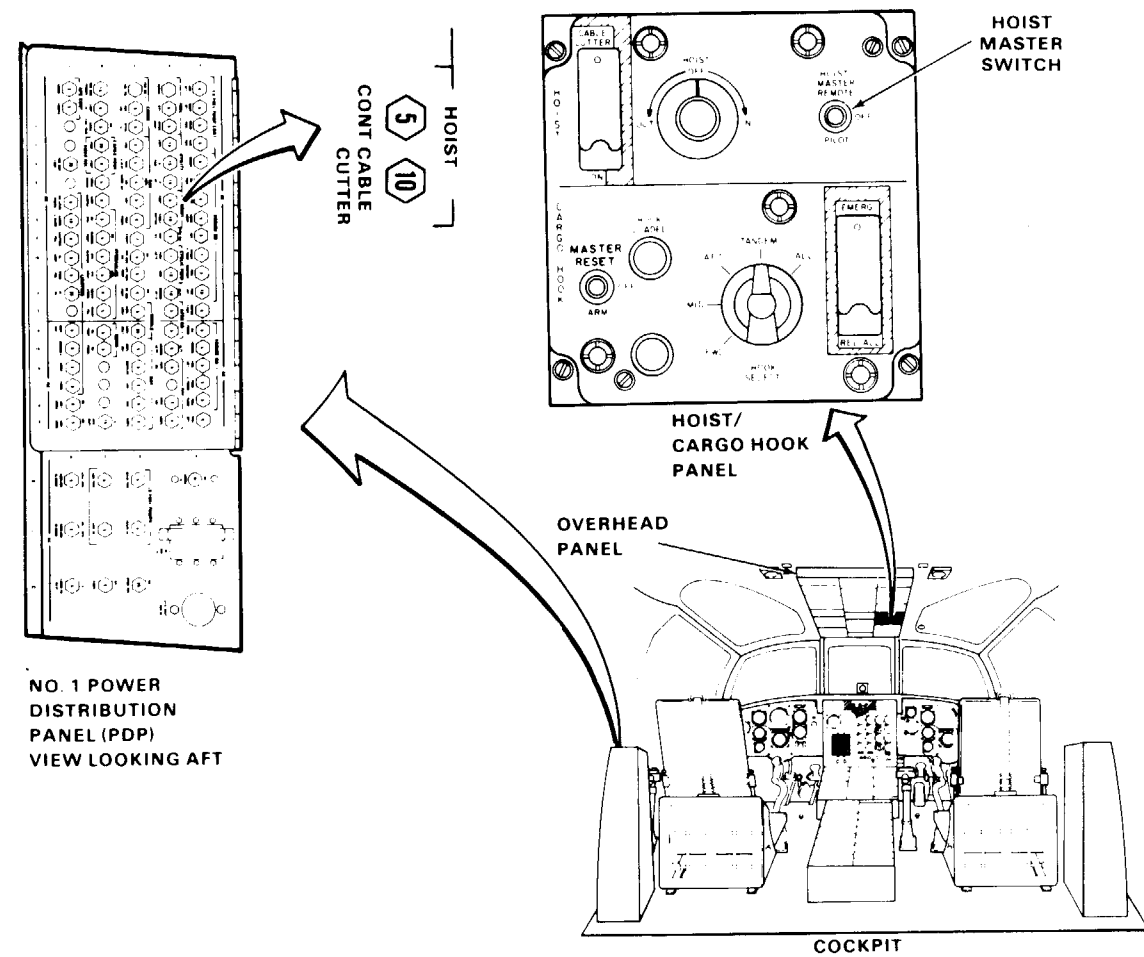
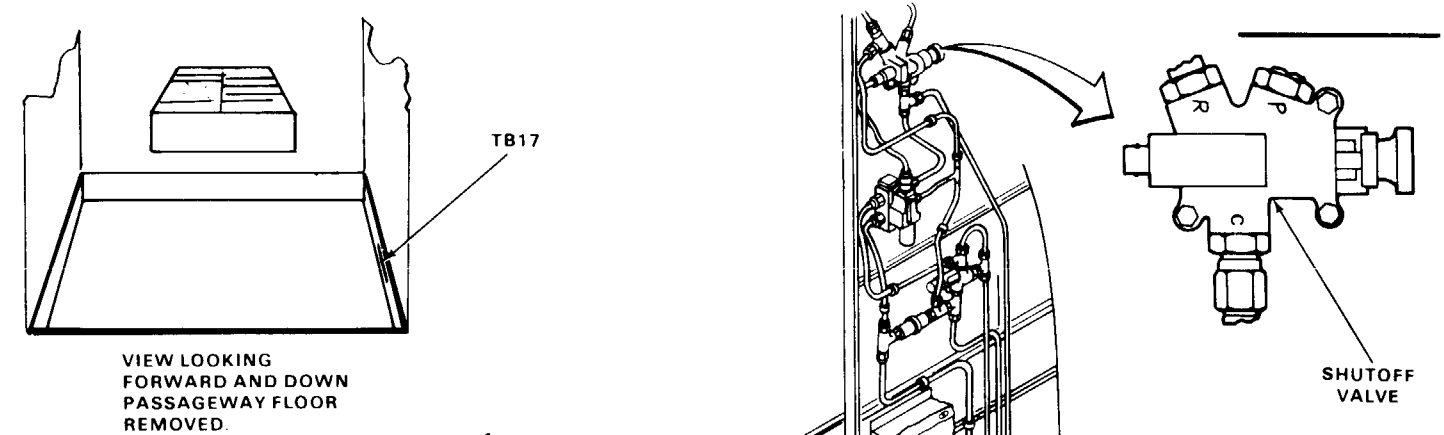

14-1.5 HOIST CONT CIRCUIT BREAKER DOES NOT STAY CLOSED (Continued)

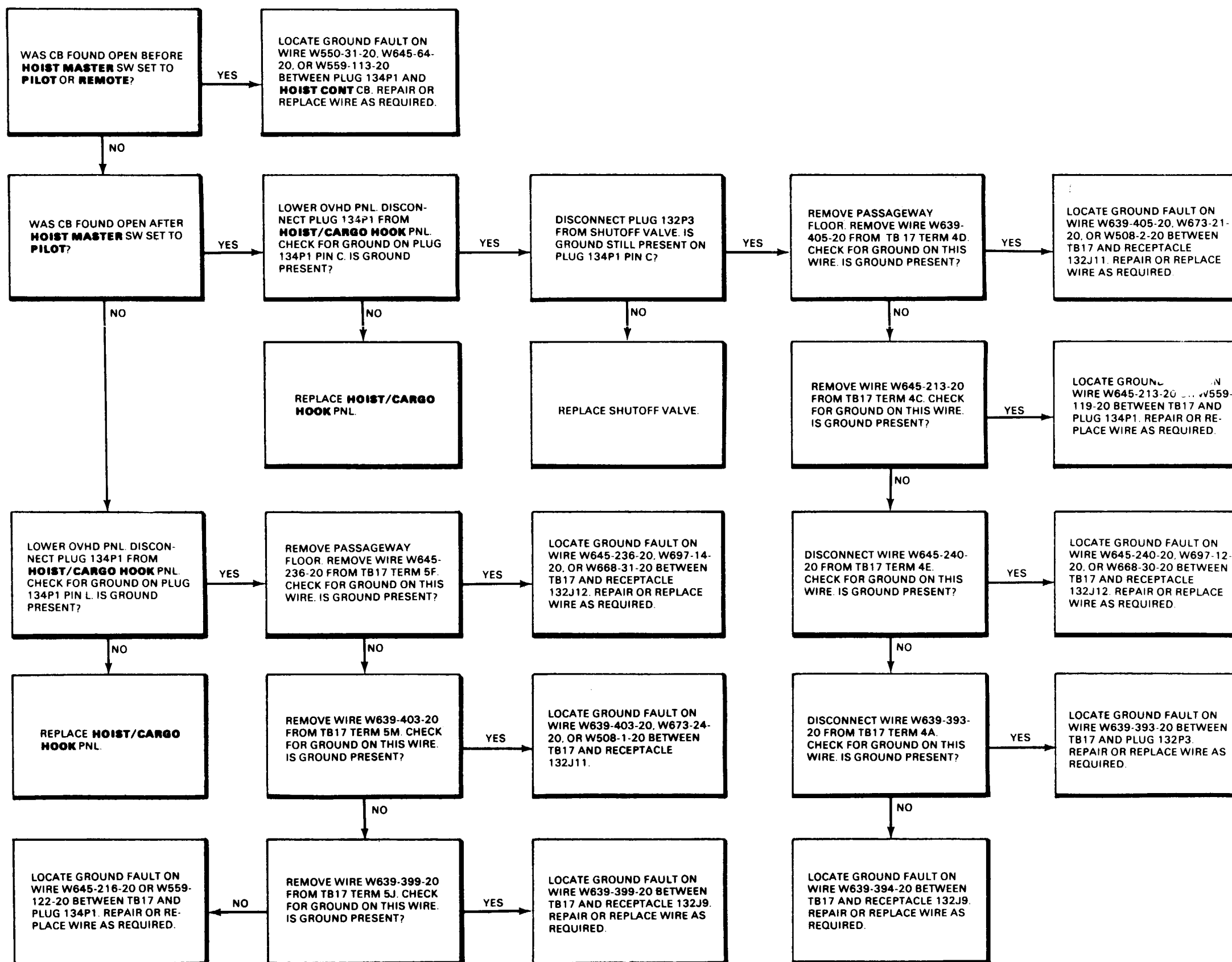

END OF TASK

14-1.6 HOIST CABLE CUTTER CIRCUIT BREAKER DOES NOT STAY CLOSED

FAULT ISOLATION PROCEDURE

INITIAL SETUP

Applicable Configurations:
All

Tools:
Electrical Repairer's Tool Kit,
NSN 5180-00-323-4915
Multimeter

Materials:
None

Personnel Required:
68F10 Aircraft Electrician
68F20 Aircraft Electrician

References:
TM 55-1520-240-23

Equipment Condition:
TM 55-1520-240-23:
Battery Disconnected
Electrical Power Off
Hydraulic Power Off

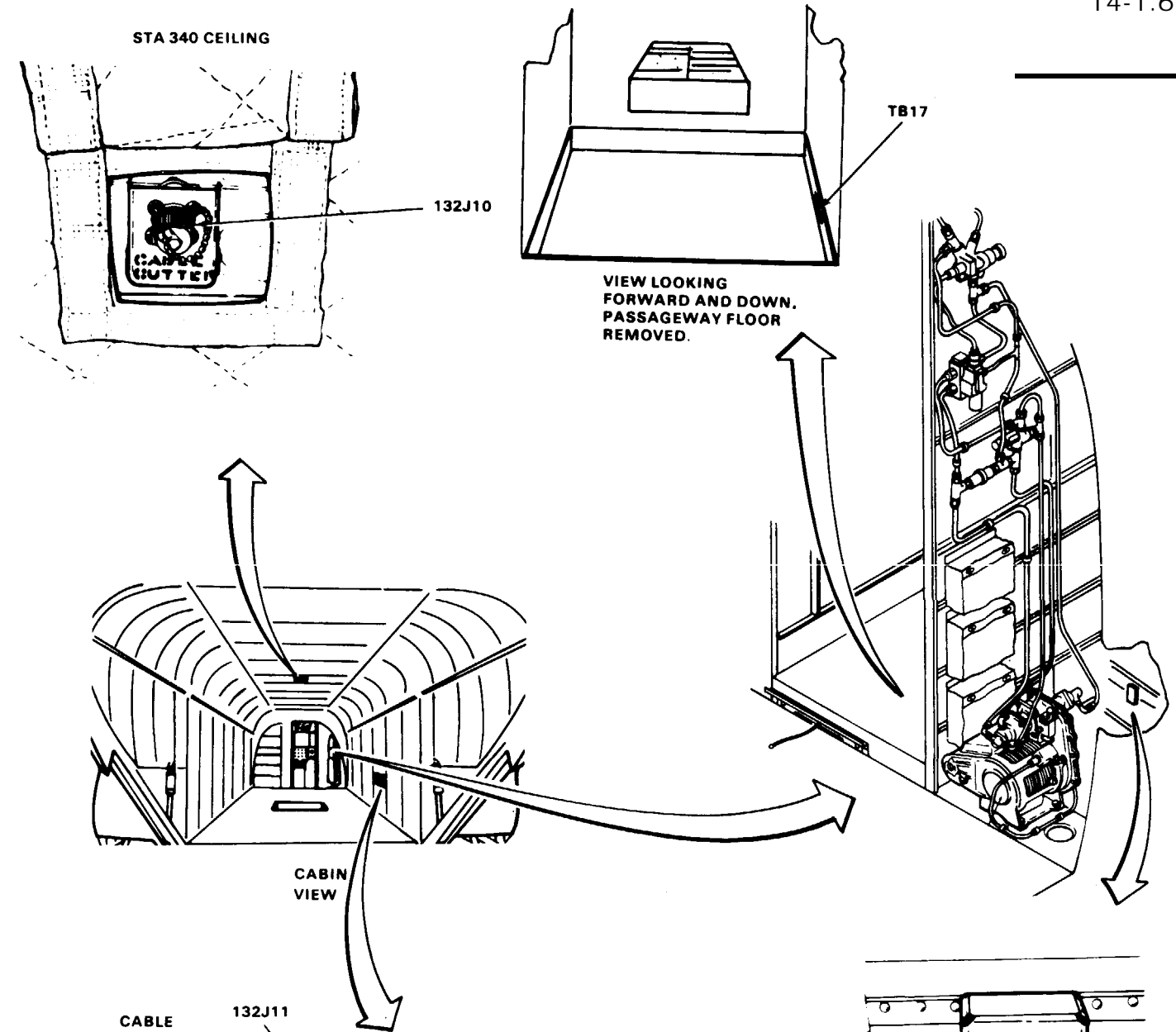
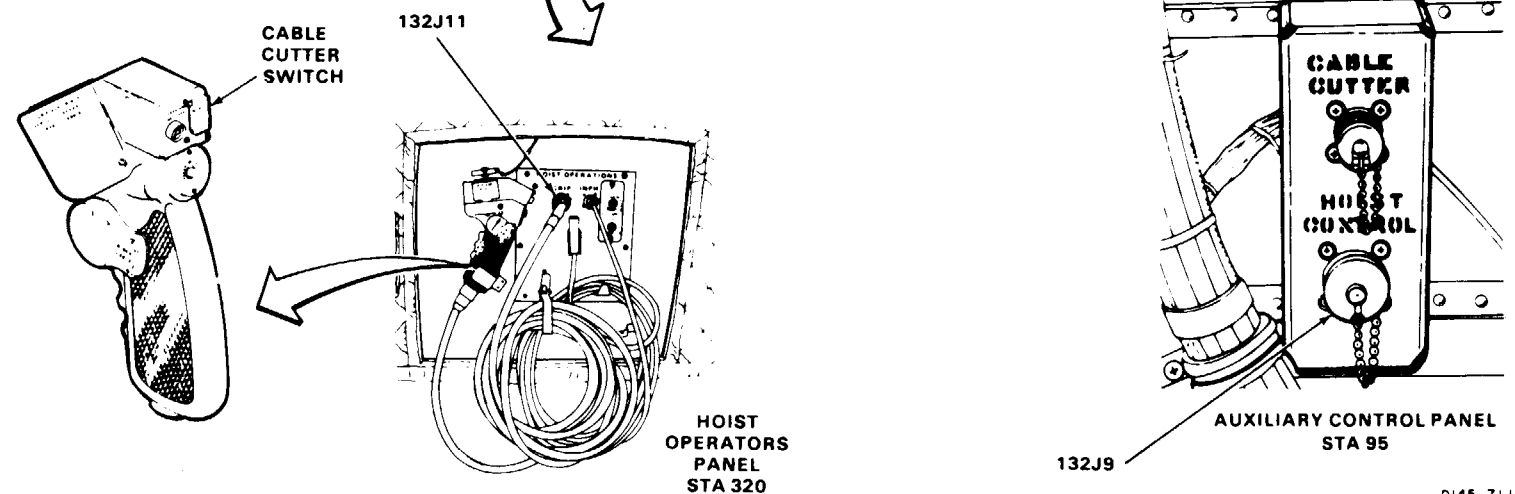
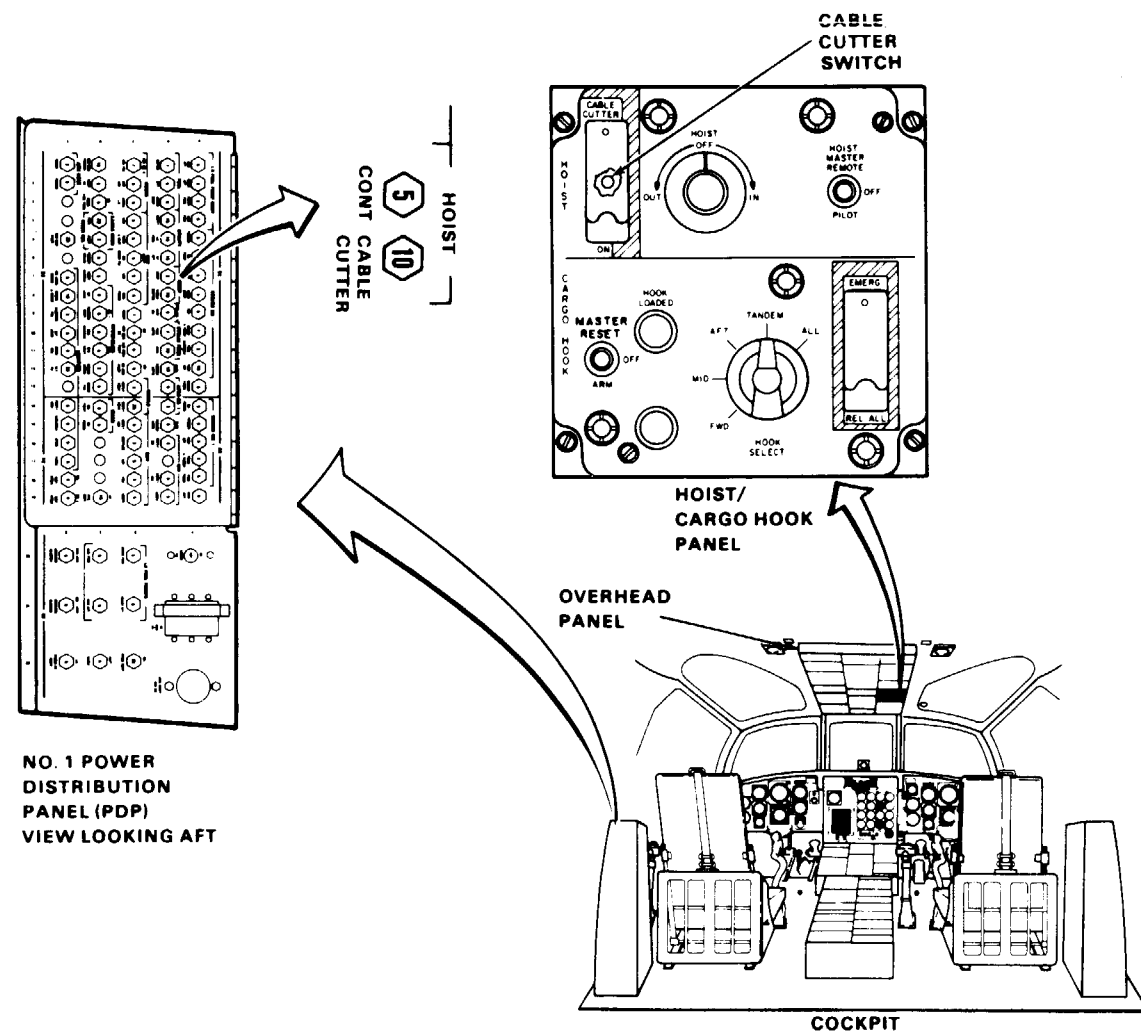

14-1.6 HOIST CABLE CUTTER CIRCUIT BREAKER DOES NOT STAY CLOSED (Continued)

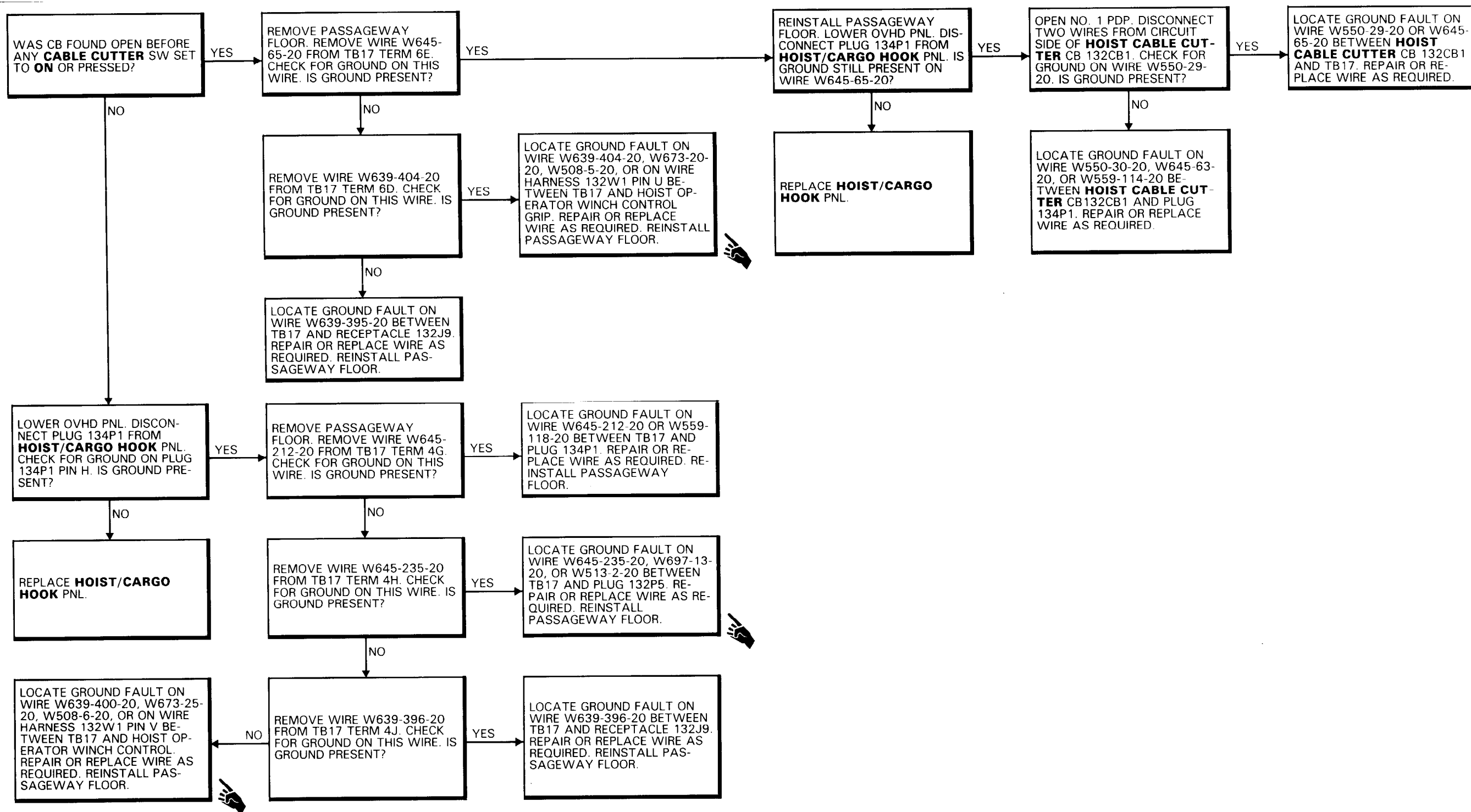

14-1.7 CABLE DOES NOT REEL OUT WHEN WINCH IS CONTROLLED AT HOIST/CARGO HOOK PANEL

FAULT ISOLATION PROCEDURE

INITIAL SETUP

Applicable Configurations:

All

Tools:

Electrical Repairer's Tool Kit,
NSN 5180-00-323-4915

Multimeter

Abestos Gloves (E187)

Materials:

None

Personnel Required:

67U10 Medium Helicopter Repairer

68F20 Aircraft Electrician

References:

TM 55-1520-240-23

Equipment Condition:

TM 55-1520-240-23:

Battery Connected

Electrical Power On

Hydraulic Power On

General Safety Instructions:

WARNING

Wear gloves when handling wire rope (cable). Otherwise, injury to hands can result.

NOTE

Have helper keep tension on wire rope (cable) when reeling cable, Cable will reel evenly and will not snarl, Helper must wear gloves.

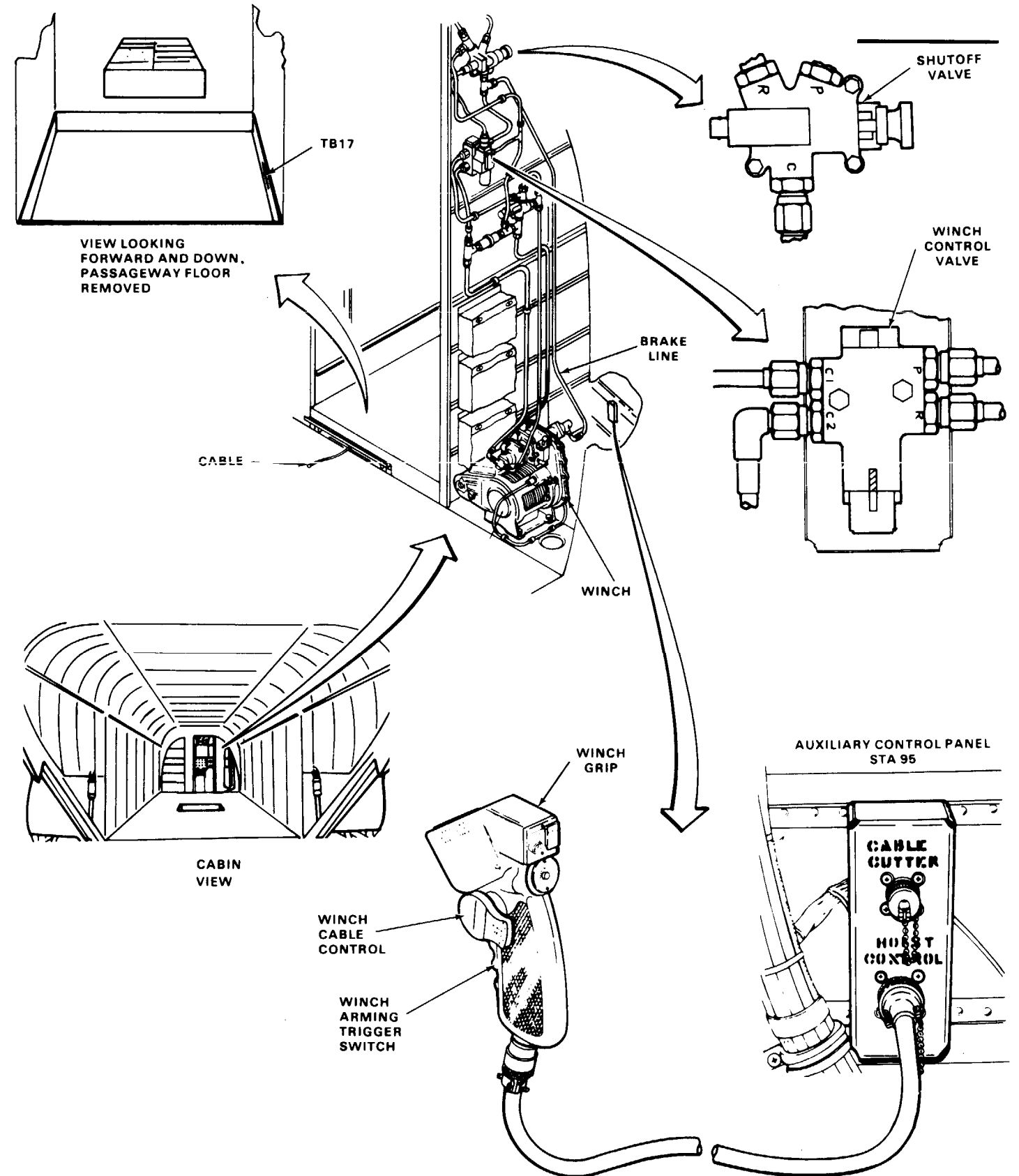
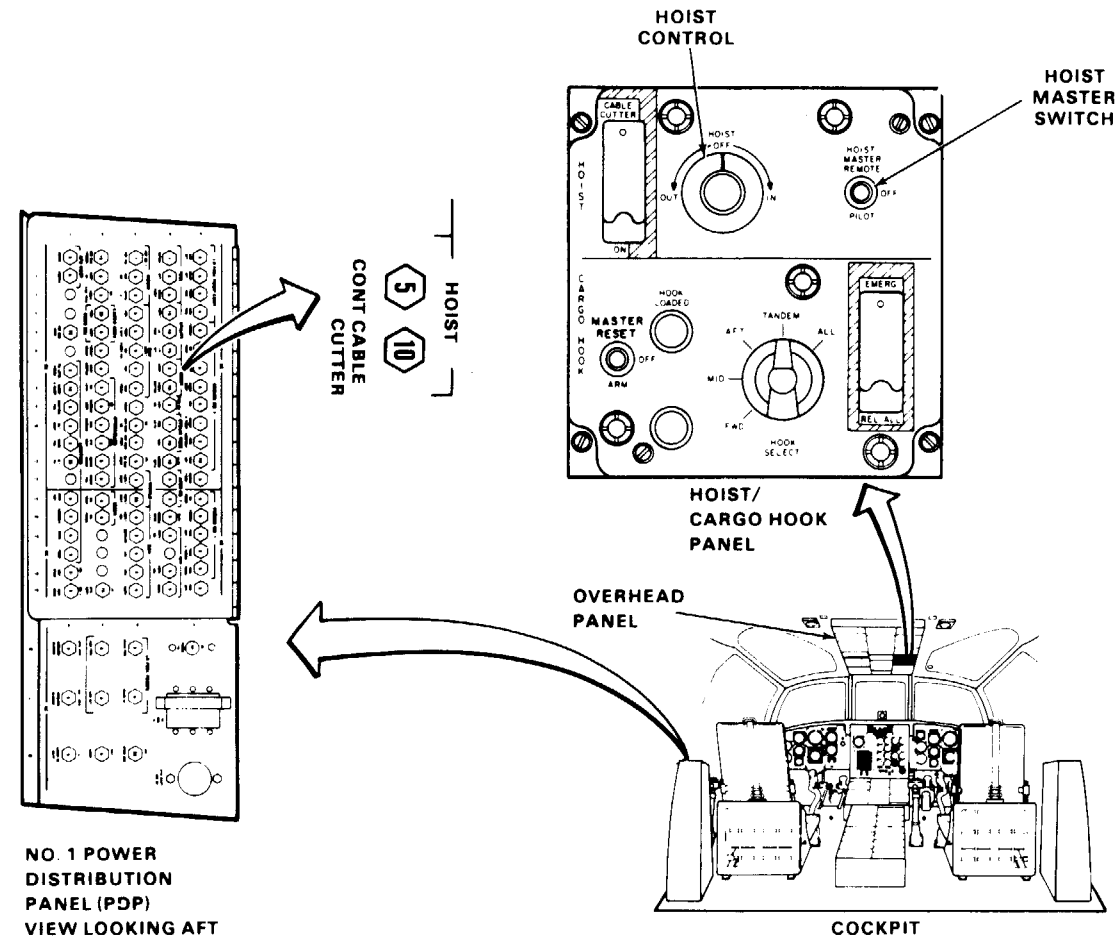

14-1.7 CABLE DOES NOT REEL OUT WHEN WINCH IS CONTROLLED AT HOIST/CARGO HOOK PANEL (Continued)

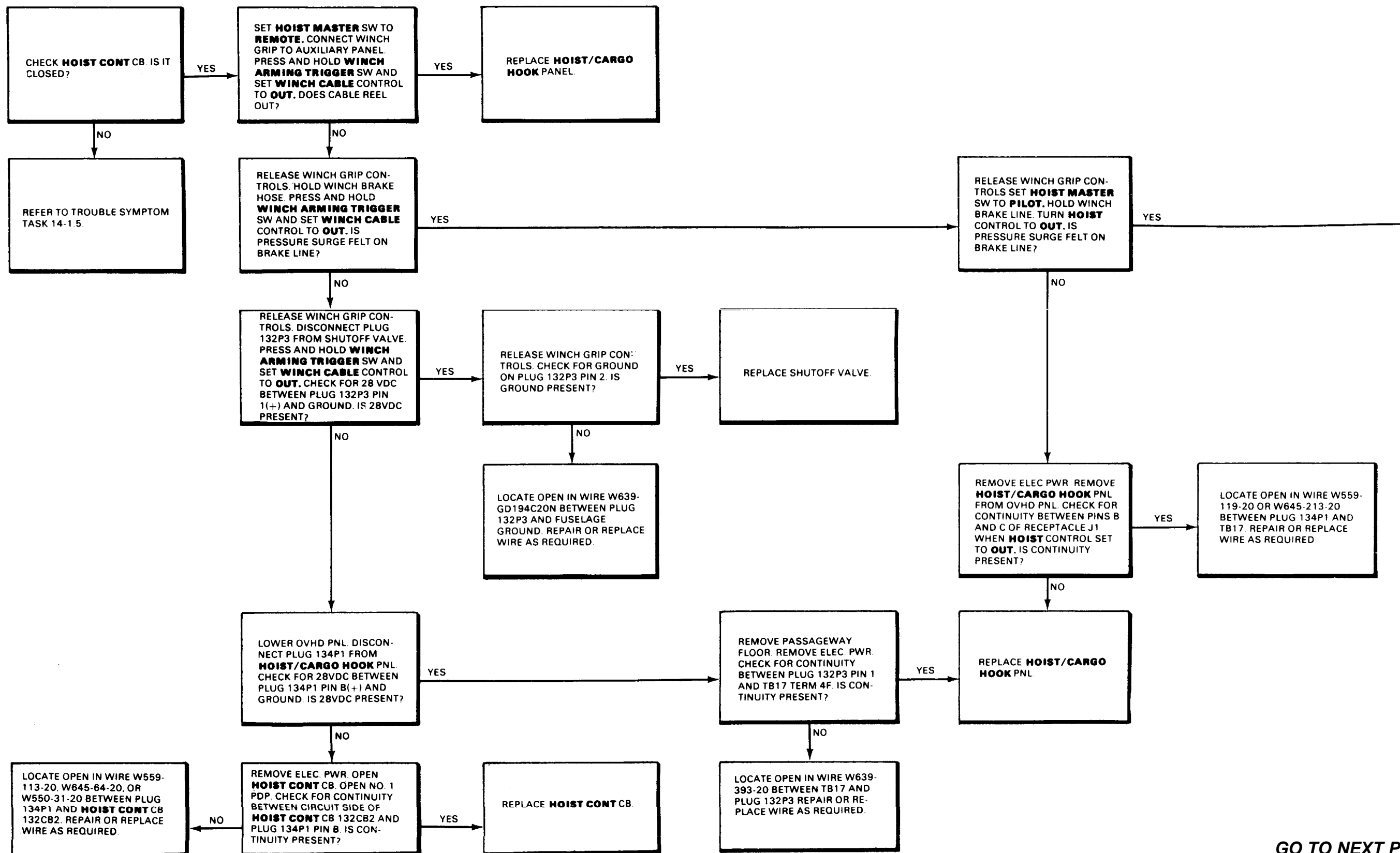

GO TO NEXT PAGE

14-1.7 CABLE DOES NOT REEL OUT WHEN WINCH IS CONTROLLED AT HOIST/CARGO HOOK PANEL (Continued)

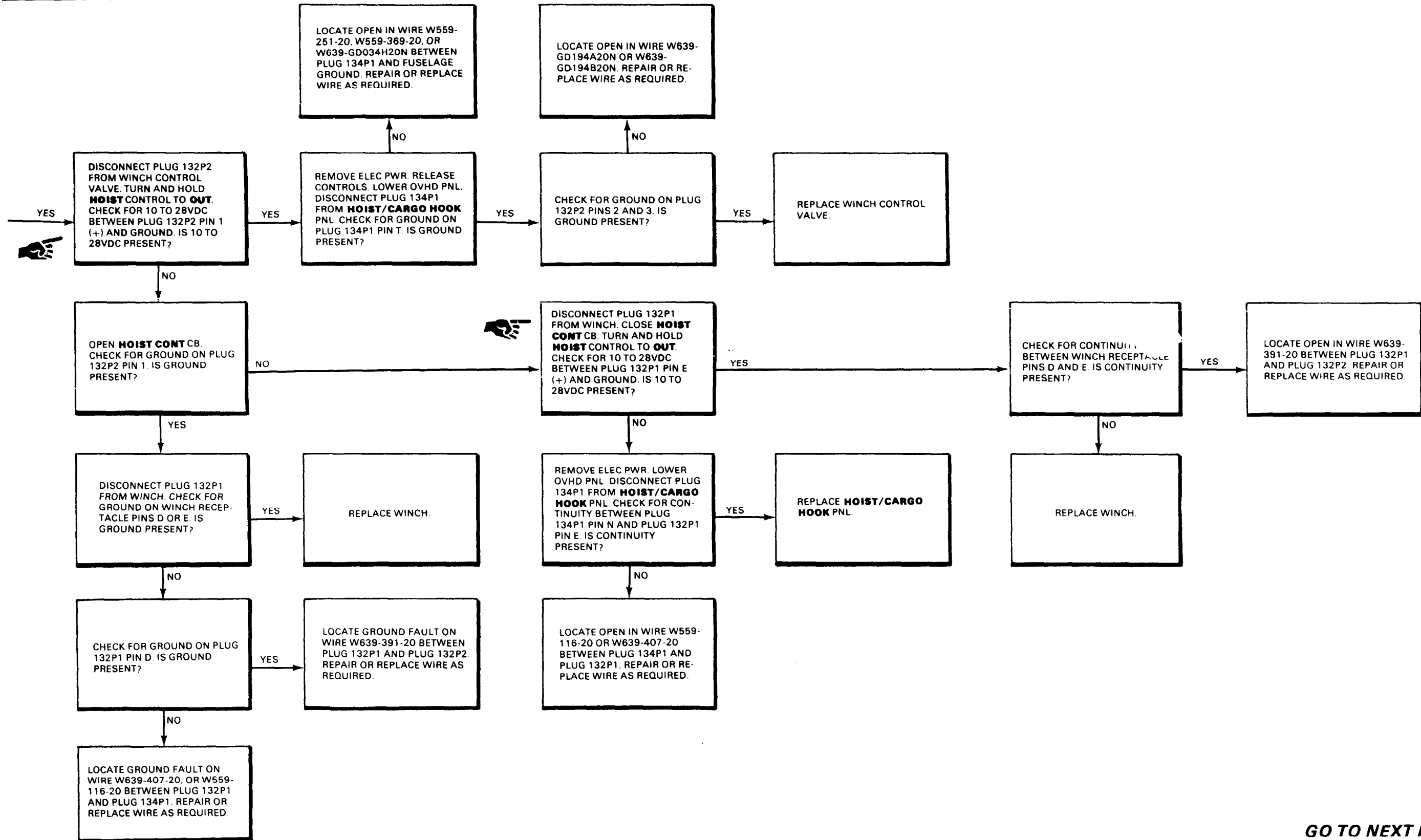

GO TO NEXT PAGE

14-1.7 CABLE DOES NOT REEL OUT WHEN WINCH IS CONTROLLED AT HOIST/CARGO HOOK PANEL (Continued)

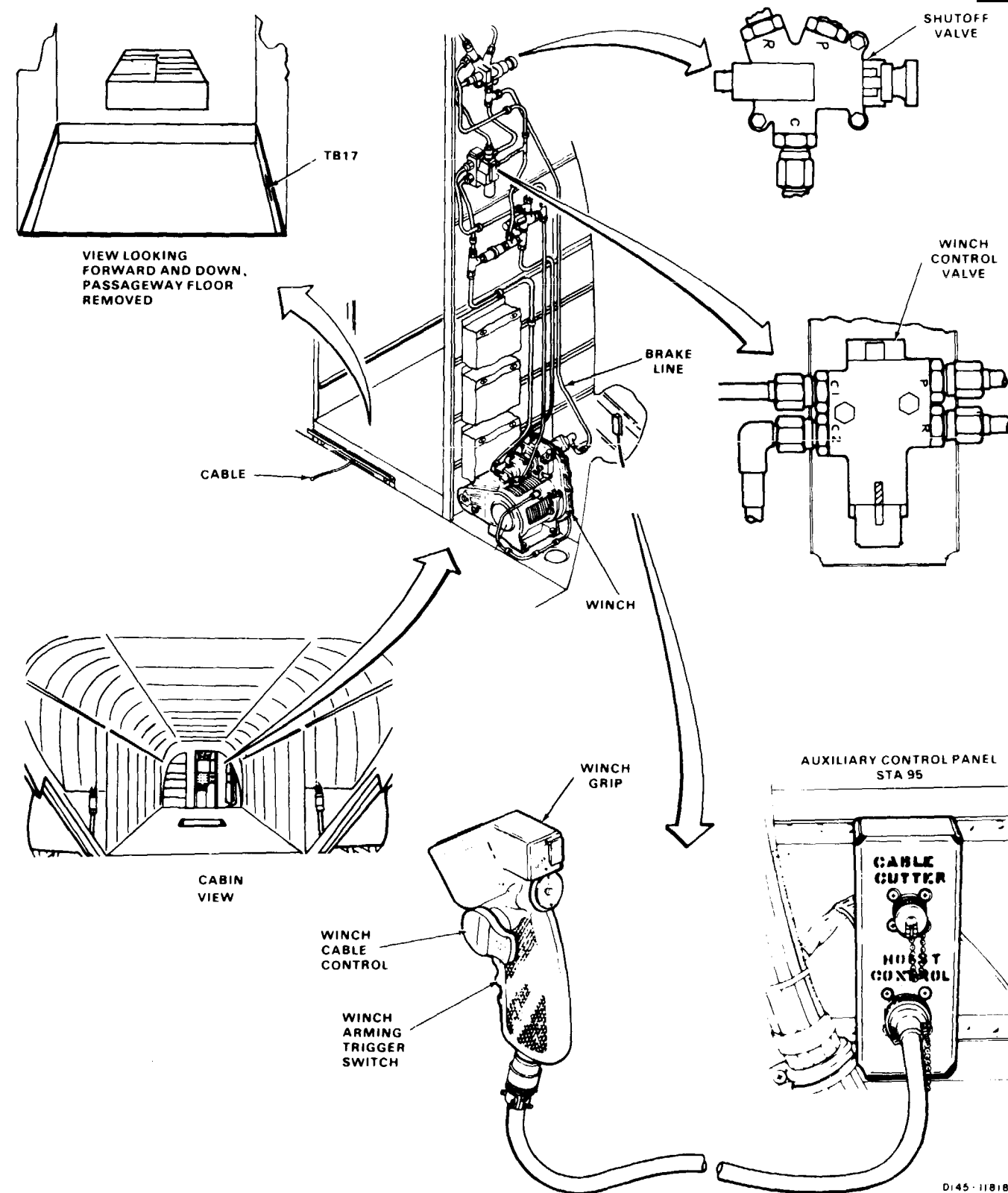
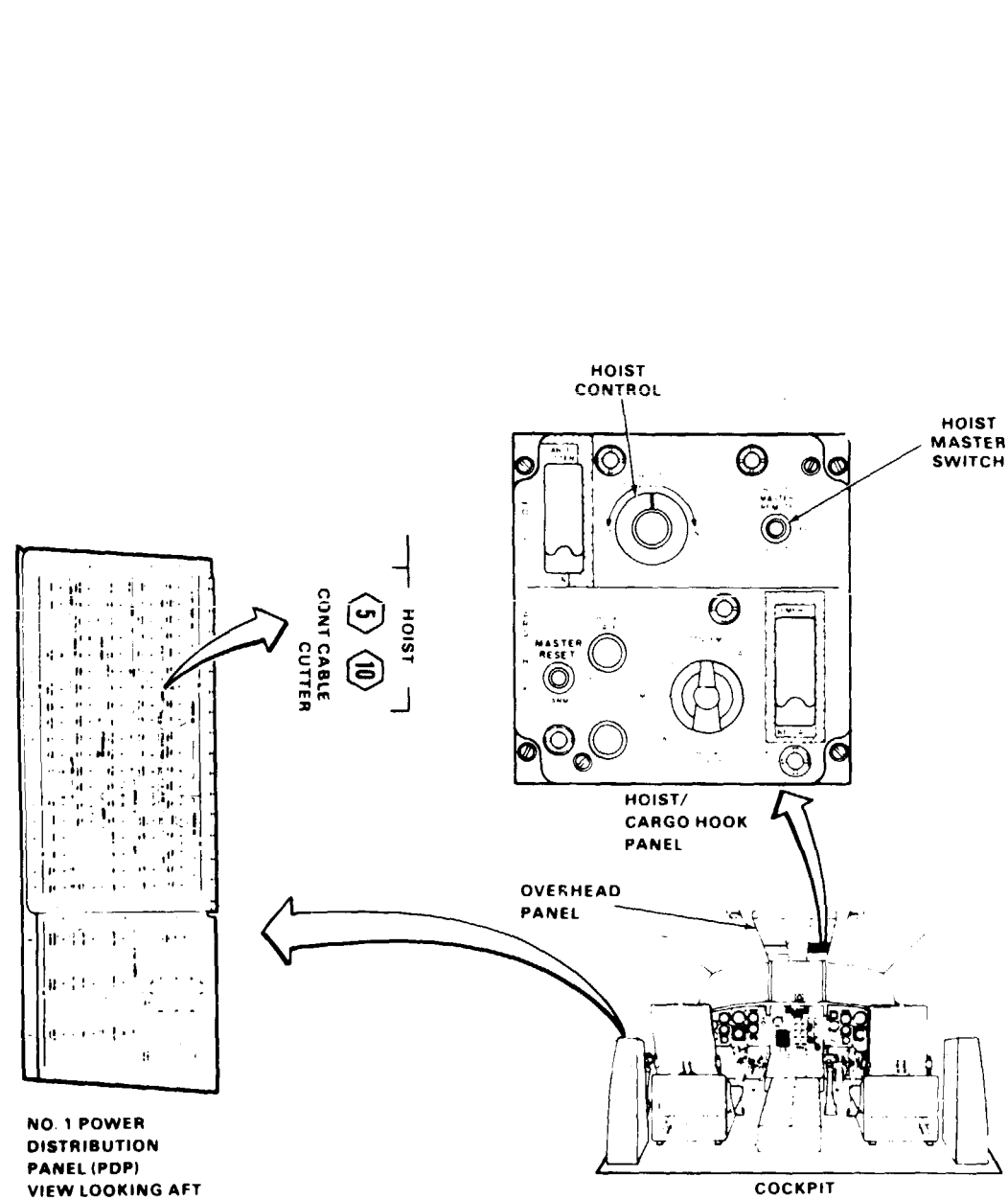

90X54

D145-1181B-SPA

END OF TASK

FAULT ISOLATION PROCEDURE

INITIAL SETUP

Applicable Configurations:

All

Tools:

- Electrical Repairer's Tool Kit,
NSN 5180-00-323-4915
- Multimeter
- Asbestos Gloves (E187)

Materials:

None

Personnel Required:

- Aircraft Electrician (2)

References:

TM 55-1520-240-23

Equipment Condition:

- TM 55-1520-240-23
- Battery Connected
- Electrical Power On
- Hydraulic Power On

General Safety Instructions:

WARNING

Cable cutter contains an electro explosive device (EED). Do not measure cutter resistance at plug pin A. Multimeter may fire EED resulting in personnel injury.

WARNING

Wear gloves when handling wire rope (cable). Otherwise injury to hands can result.

NOTE

Have helper keep tension on wire rope (cable) when reeling cable. Cable will reel evenly and will not snarl. Helper must wear gloves.

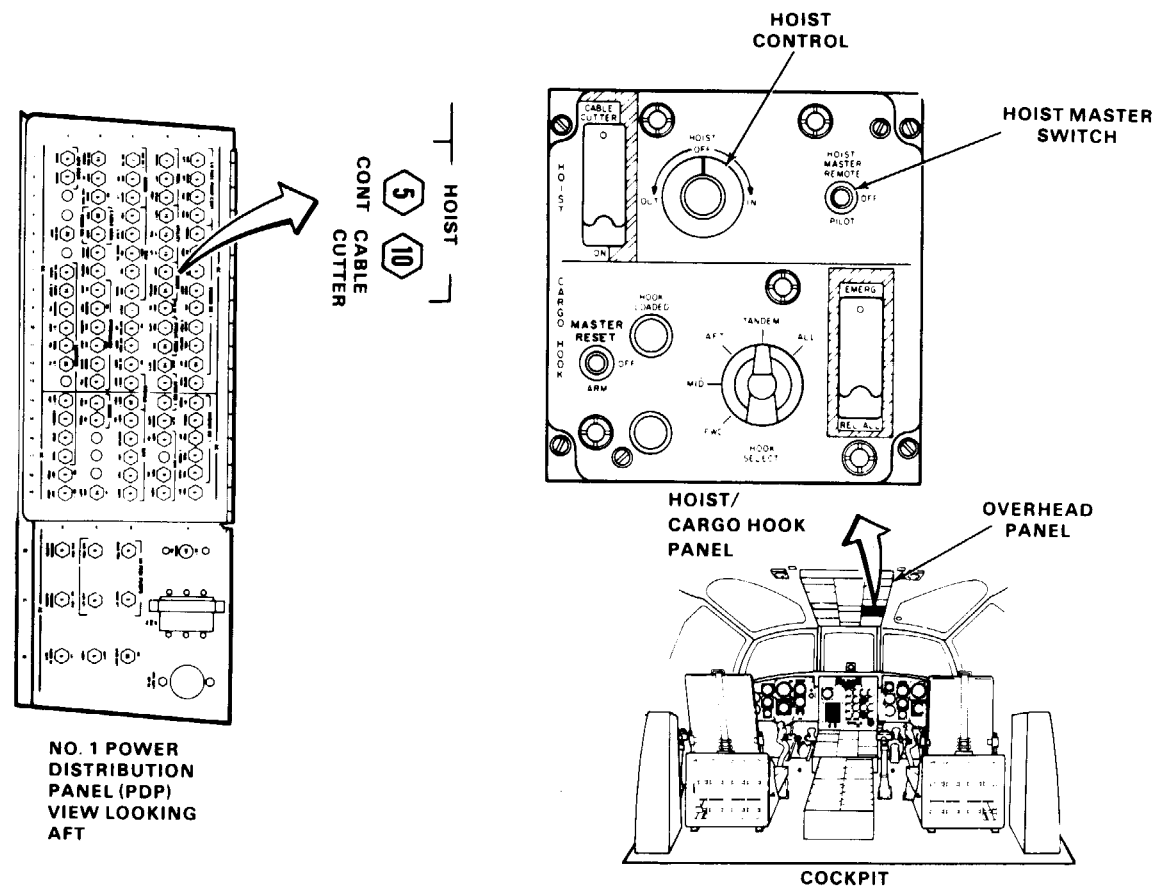
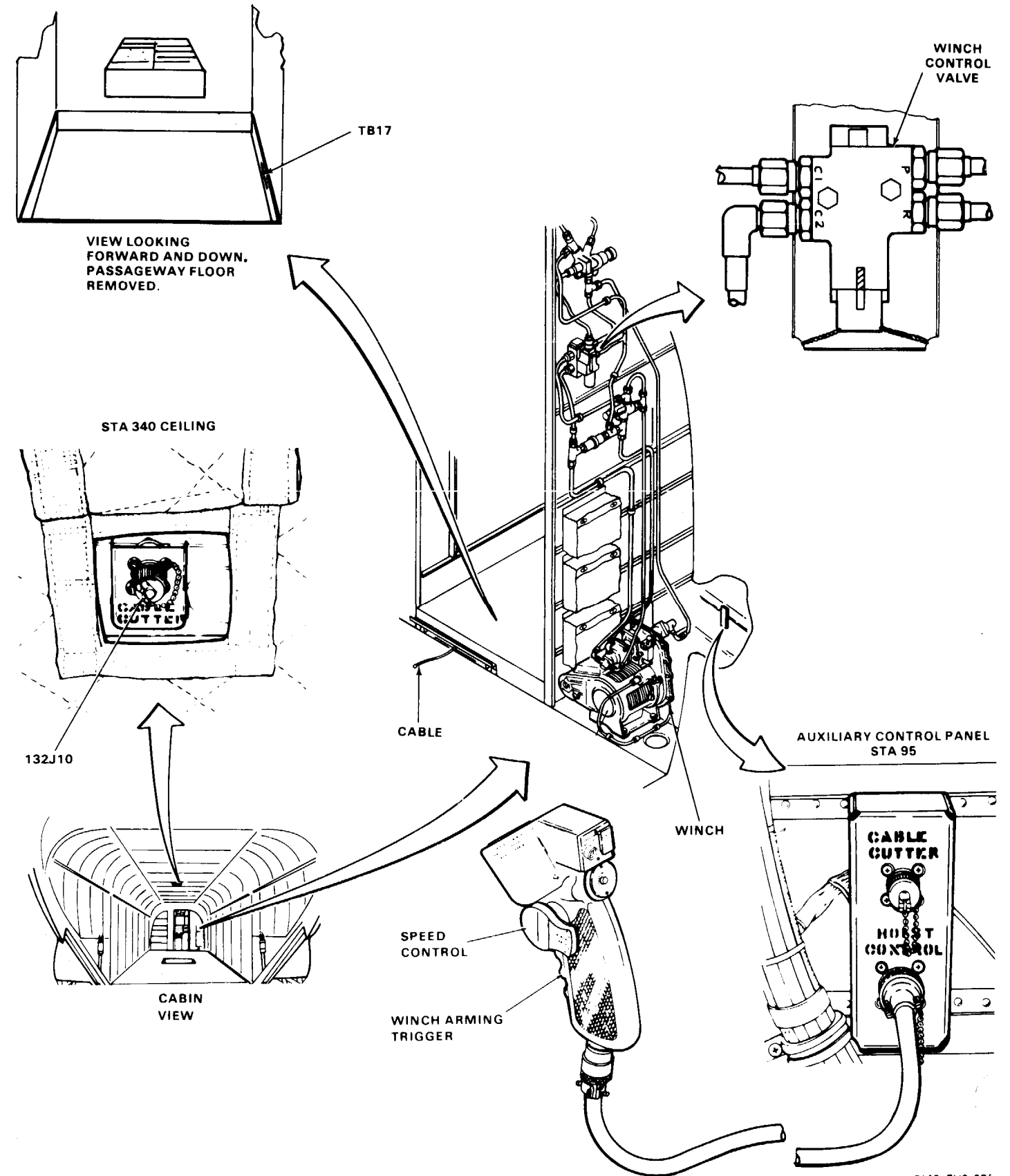

90x54

D145-7112-SP

14-1.8 CABLE DOES NOT REEL IN WHEN WINCH IS CONTROLLED AT HOIST/CARGO HOOK PANEL
(Continued)

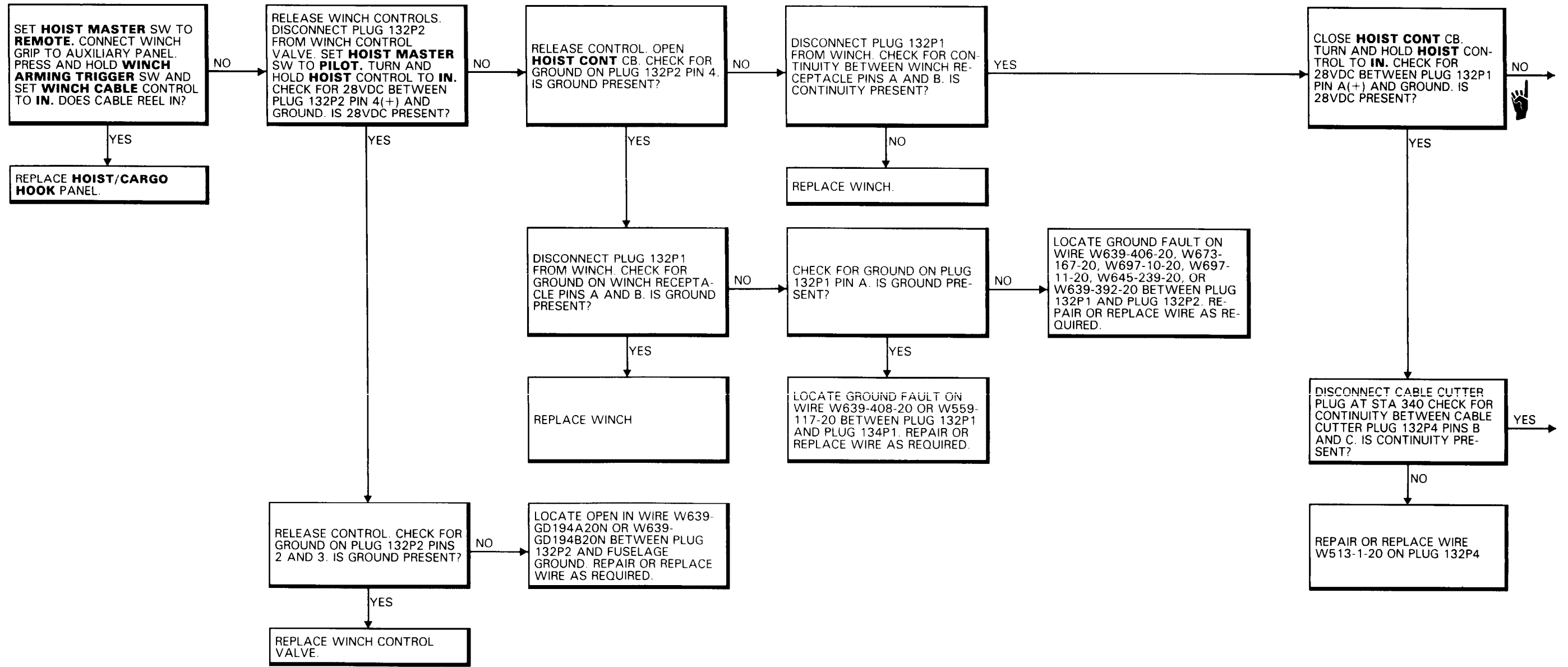

14-1.8 CABLE DOES NOT REEL IN WHEN WINCH IS CONTROLLED AT HOIST/CARGO HOOK PANEL (Continued)

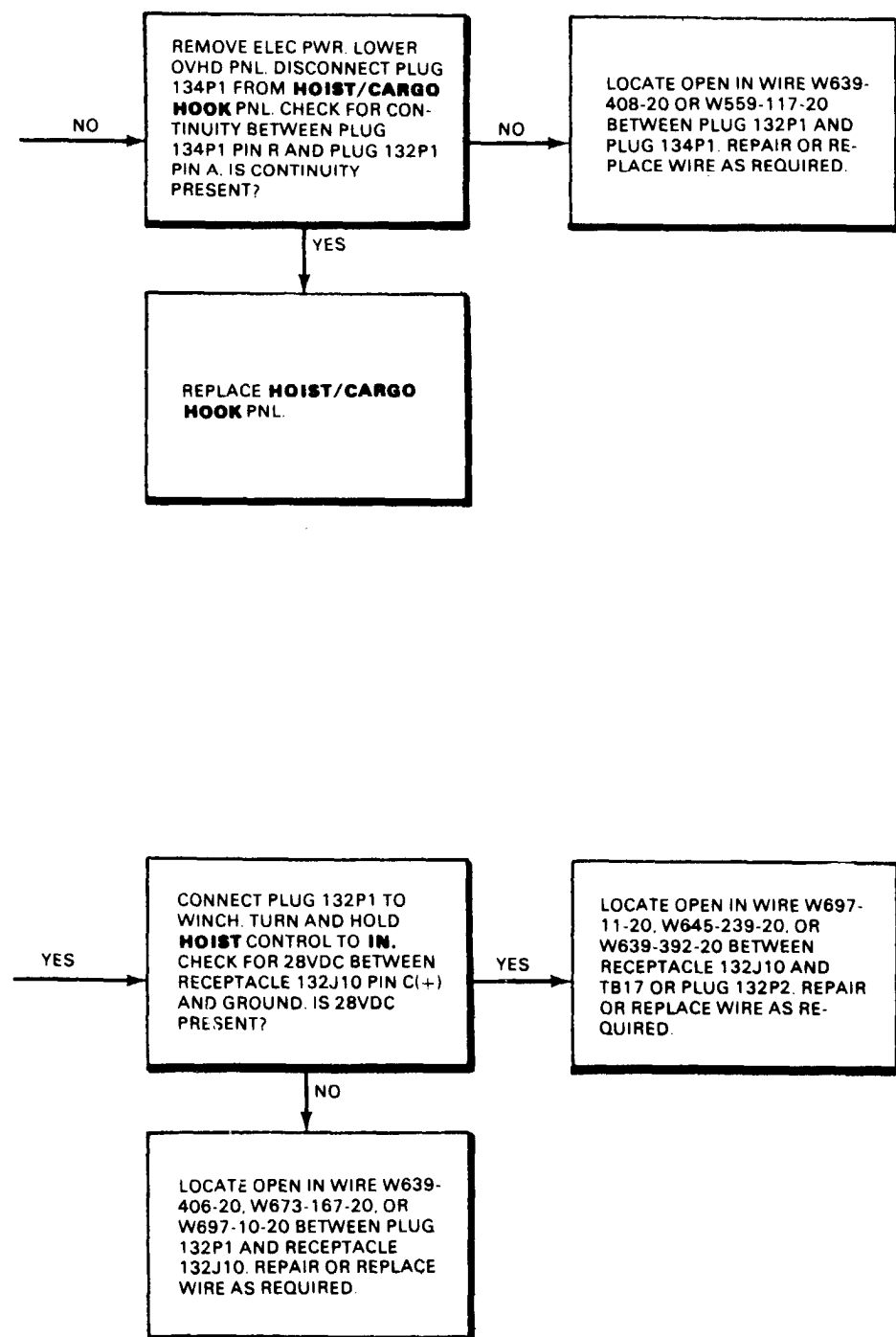

14-1.8 CABLE DOES NOT REEL IN WHEN WINCH IS CONTROLLED AT HOIST/CARGO HOOK PANEL (Continued)

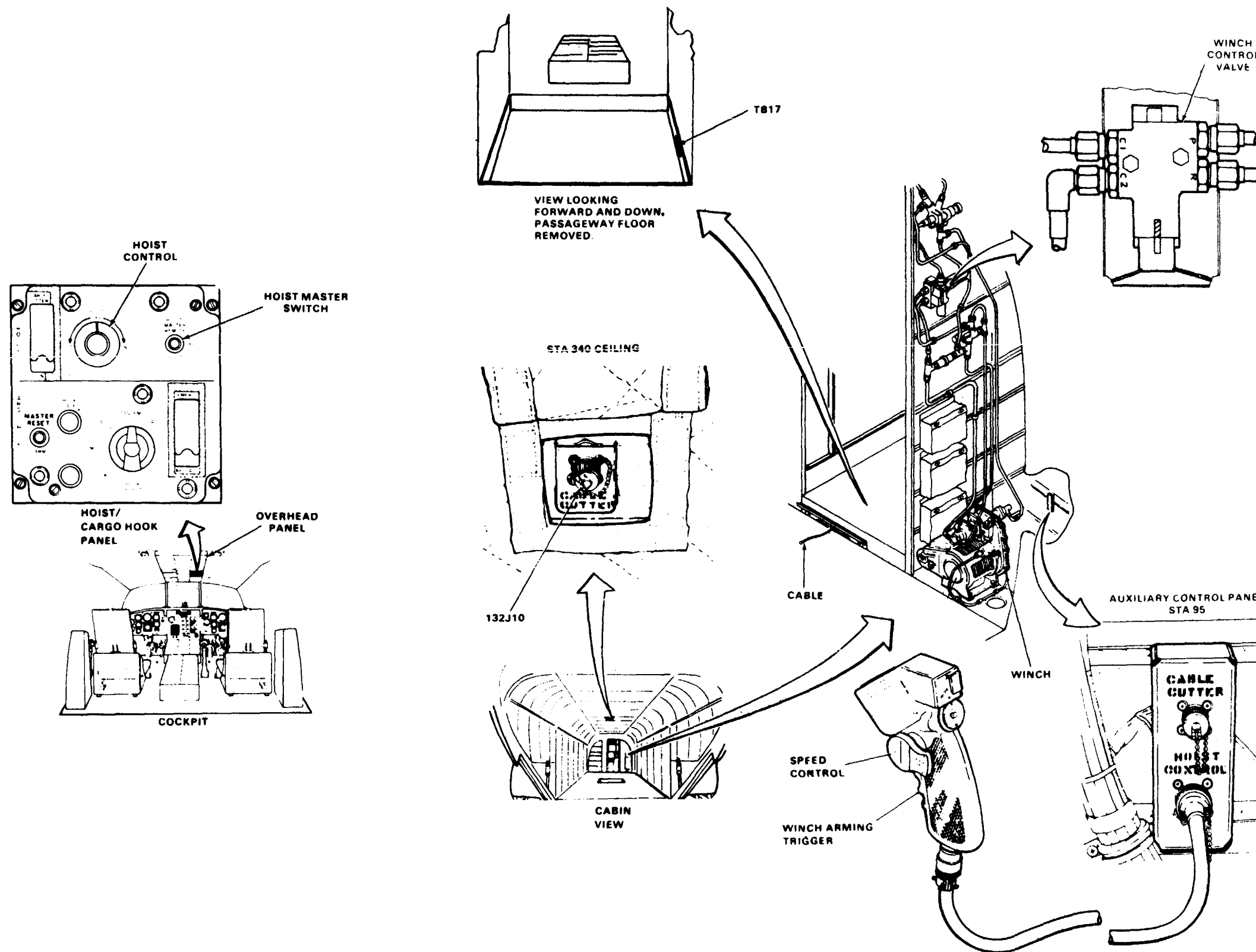

14-1.9 CABLE DOES NOT REEL OUT WHEN WINCH IS CONTROLLED BY WINCH CONTROL GRIP AT STA 95 AUXILIARY PANEL

FAULT ISOLATION PROCEDURE

INITIAL SETUP

Applicable Configurations:
All

Tools:
Electrical Repairer's Tool Kit,
NSN 5180-00-323-4915
Multimeter
Asbestos Gloves (E187)

Materials:
None

Personnel Required:
68F10 Aircraft Electrician
68F20 Aircraft Electrician

References:
TM 55-1520-240-23

Equipment Condition:
TM 55-1520-240-23:
Battery Connected
Electrical Power On
Hydraulic Power On

General Safety Instructions:

WARNING

Wear gloves when handling wire rope (cable). Otherwise injury to hands can result.

NOTE

Have helper keep tension on wire rope (cable) when reeling cable. Cable will reel evenly and will not snarl. Helper must wear gloves.

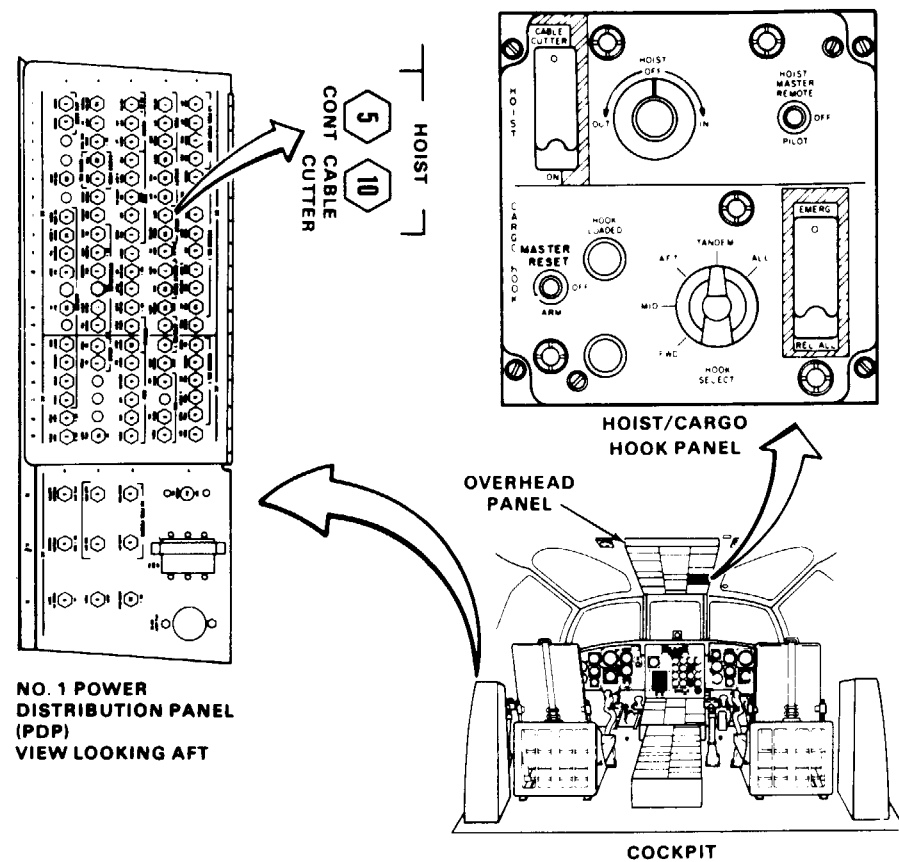
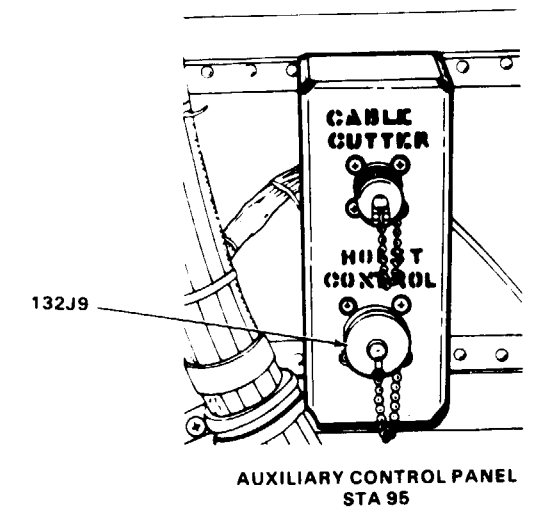
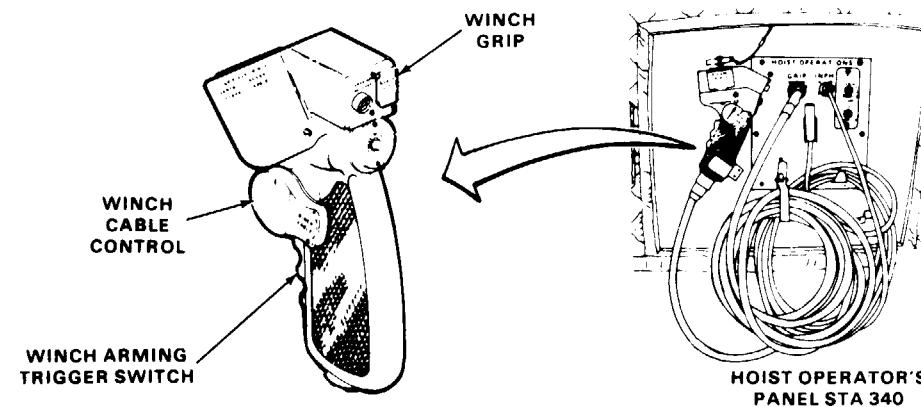
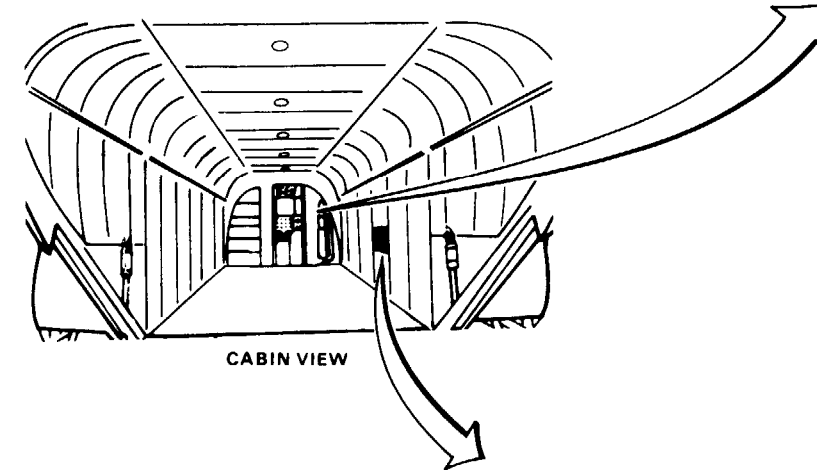
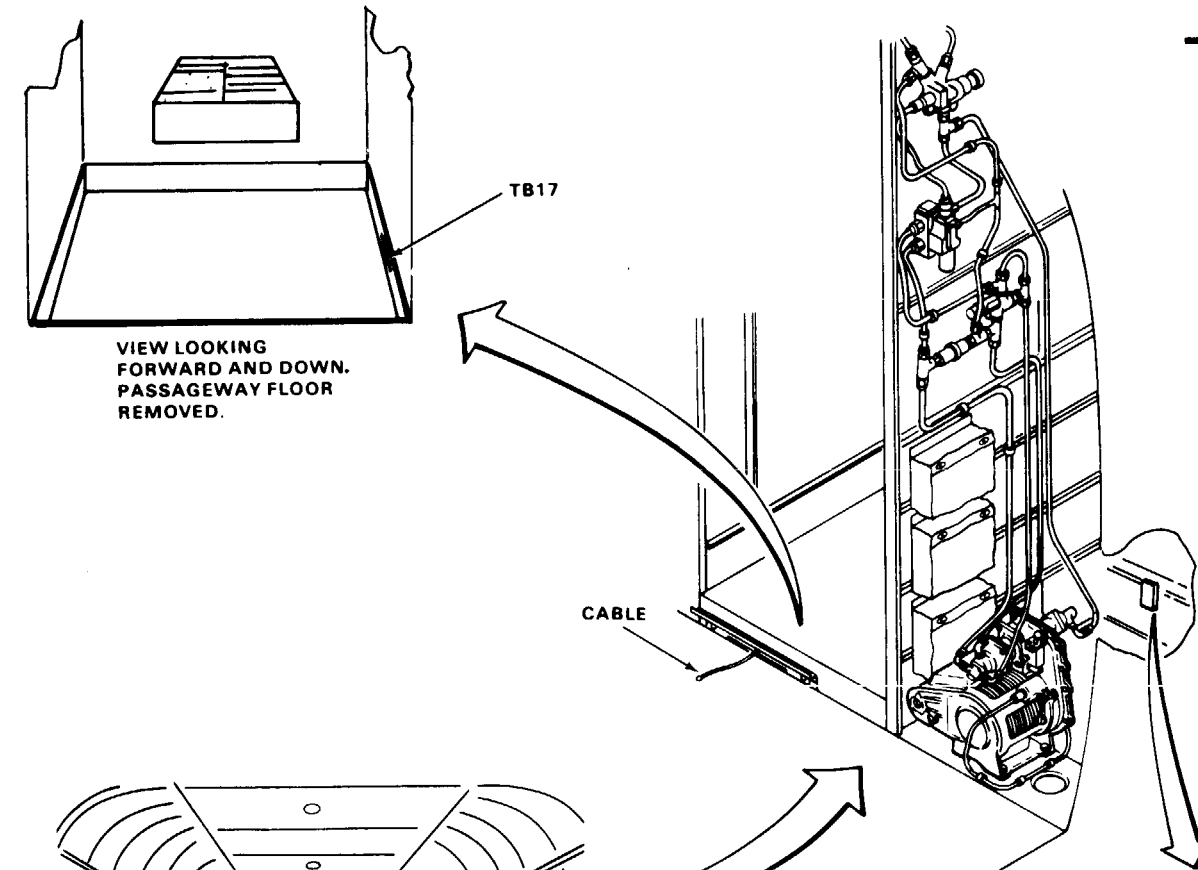

14-1.9 CABLE DOES NOT REEL OUT WHEN WINCH IS CONTROLLED BY WINCH CONTROL GRIP AT STA 95 AUXILIARY PANEL (Continued)

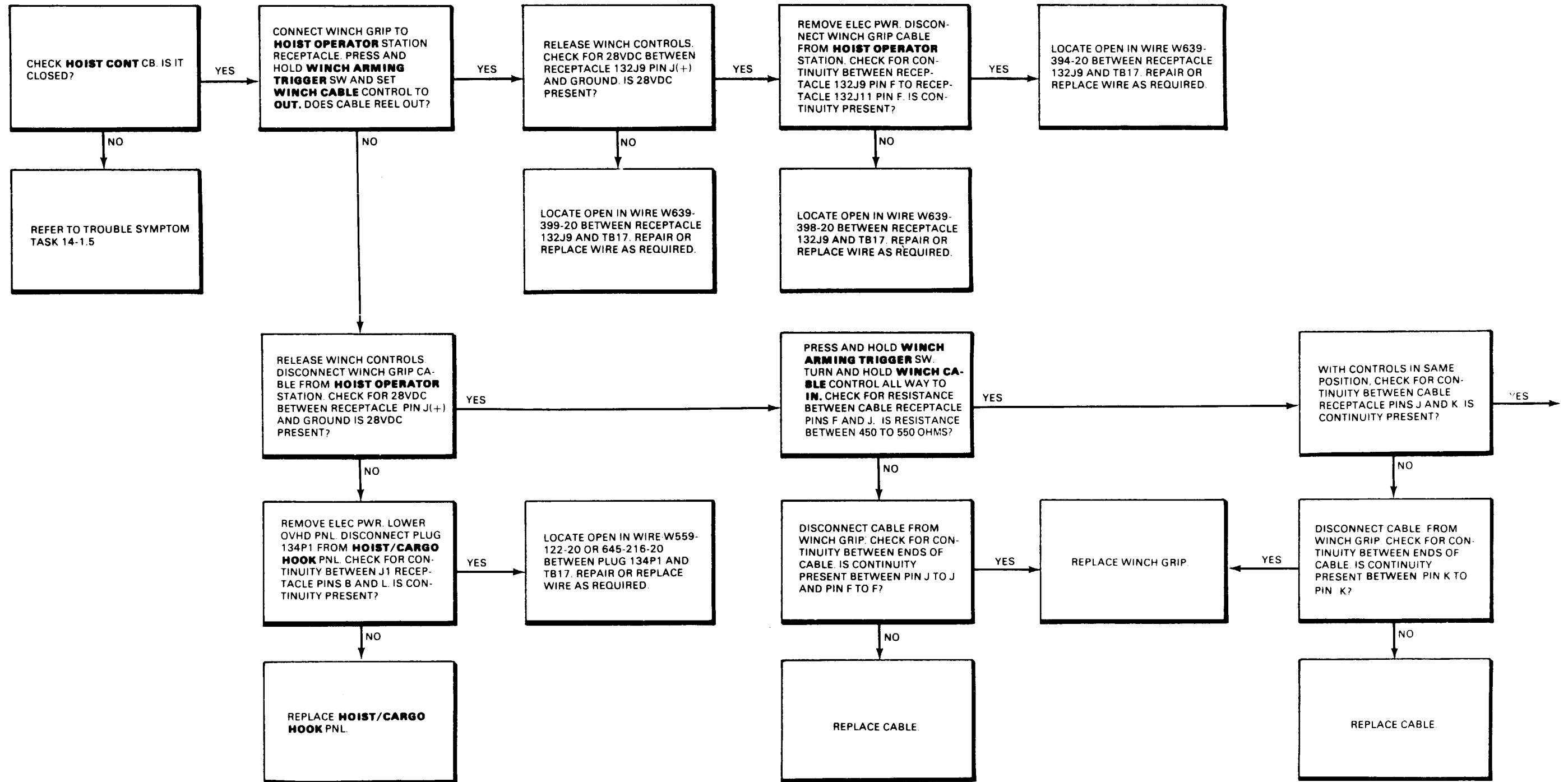

GO TO NEXT PAGE

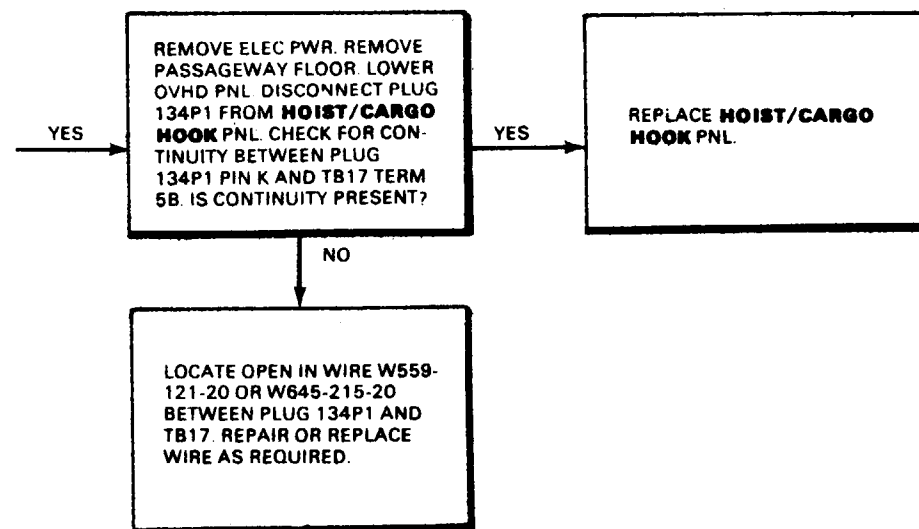

14-1.9 CABLE DOES NOT REEL OUT WHEN WINCH IS CONTROLLED BY WINCH CONTROL GRIP AT STA 95 AUXILIARY PANEL (Continued)

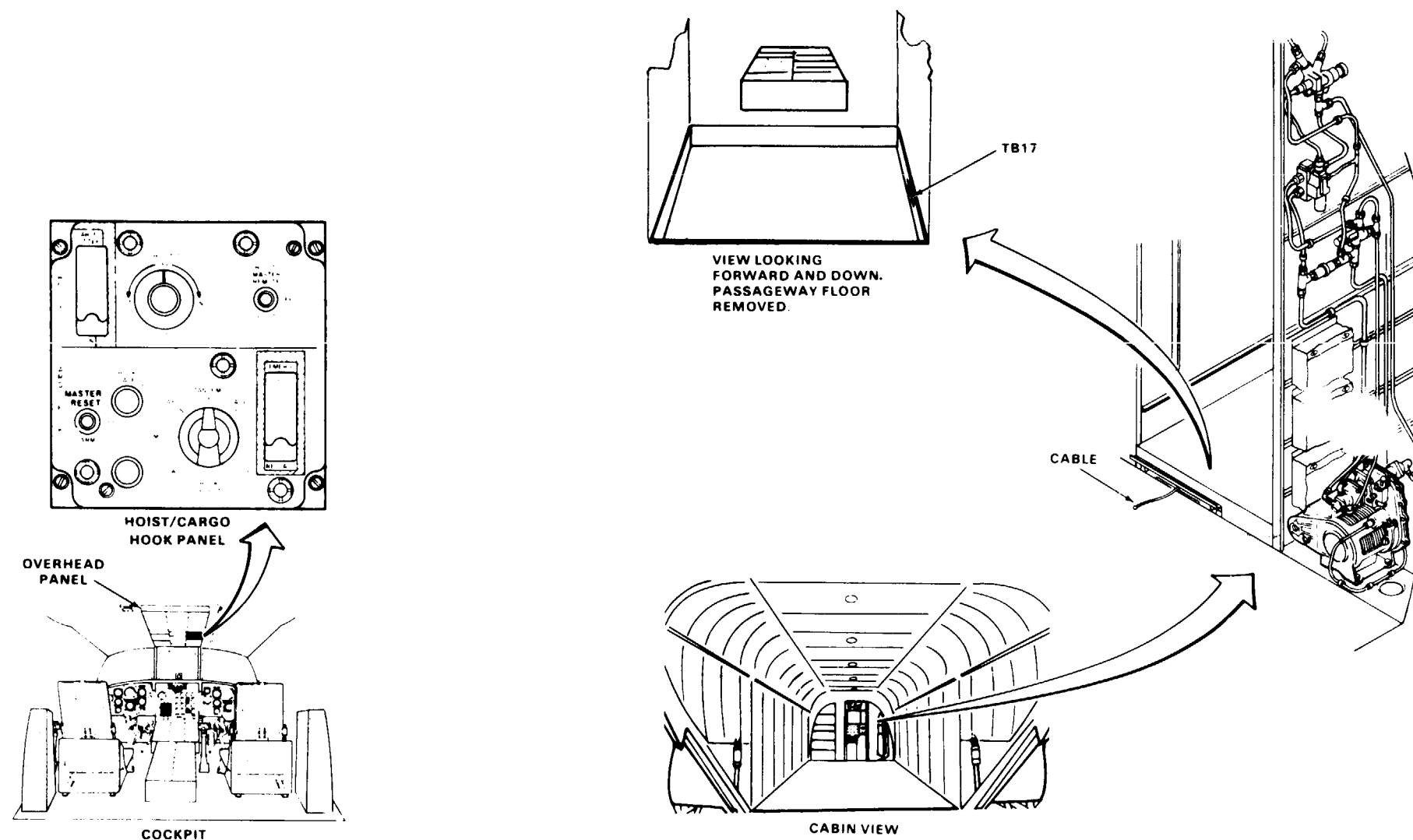

14-1.10 CABLE DOES NOT REEL IN WHEN WINCH IS CONTROLLED BY WINCH GRIP AT STA 95 AUXILIARY PANEL

FAULT ISOLATION PROCEDURE

INITIAL SETUP

Applicable Configurations:
All

Tools:
Electrical Repairer's Tool Kit,
NSN 5180-00-323-4915
Multimeter
Asbestos Gloves (E187)

Materials:
None

Personnel Required:
68F10 Aircraft Electrician
68F20 Aircraft Electrician

References:
TM 55-1520-240-23

Equipment Condition:
TM 55-1520-240-23:
Battery Connected
Electrical Power On
Hydraulic Power On

General Safety Instructions:

WARNING

Wear gloves when handling wire rope (cable). Otherwise injury to hands can result.

NOTE

Have helper keep tension on wire rope (cable) when reeling cable. Cable will reel evenly and will not snarl. Helper must wear gloves.

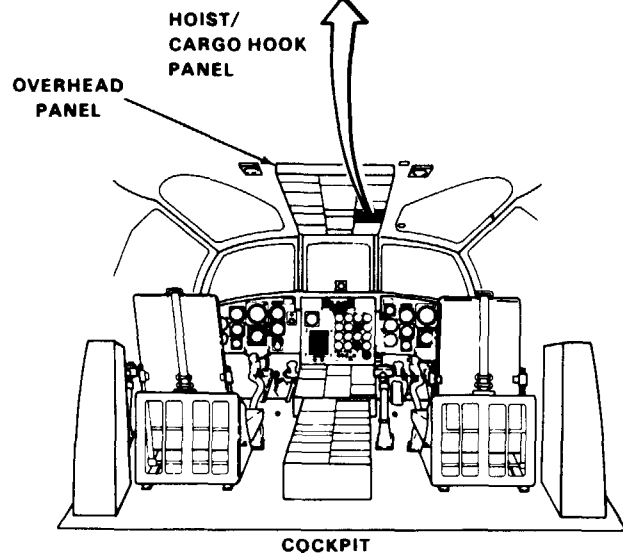
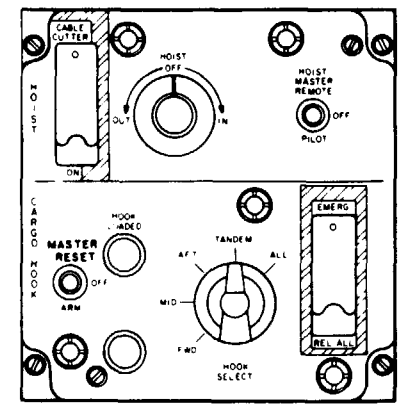
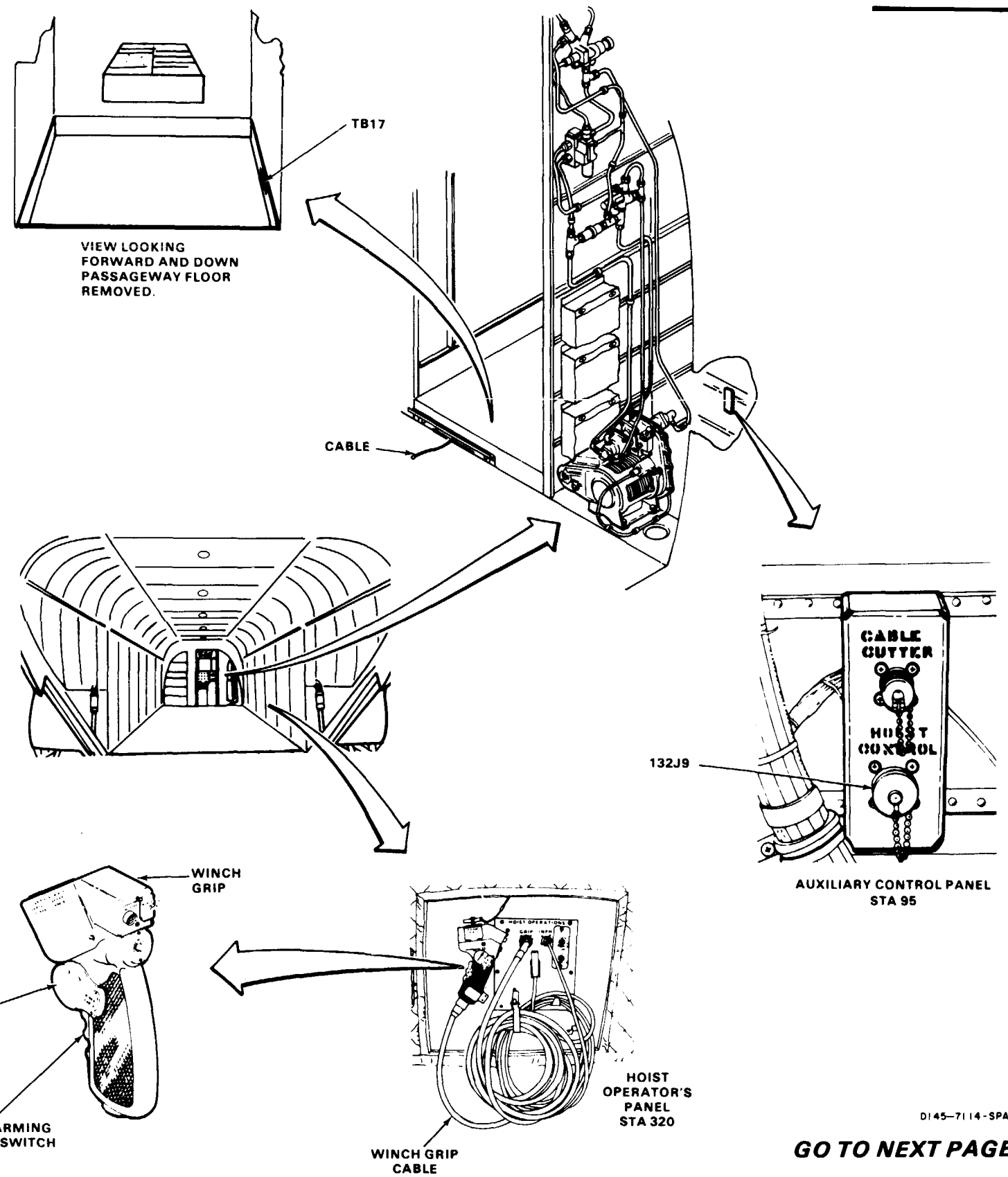

14-1.10 CABLE DOES NOT REEL IN WHEN WINCH IS CONTROLLED BY WINCH GRIP AT STA 95 AUXILIARY PANEL (Continued)

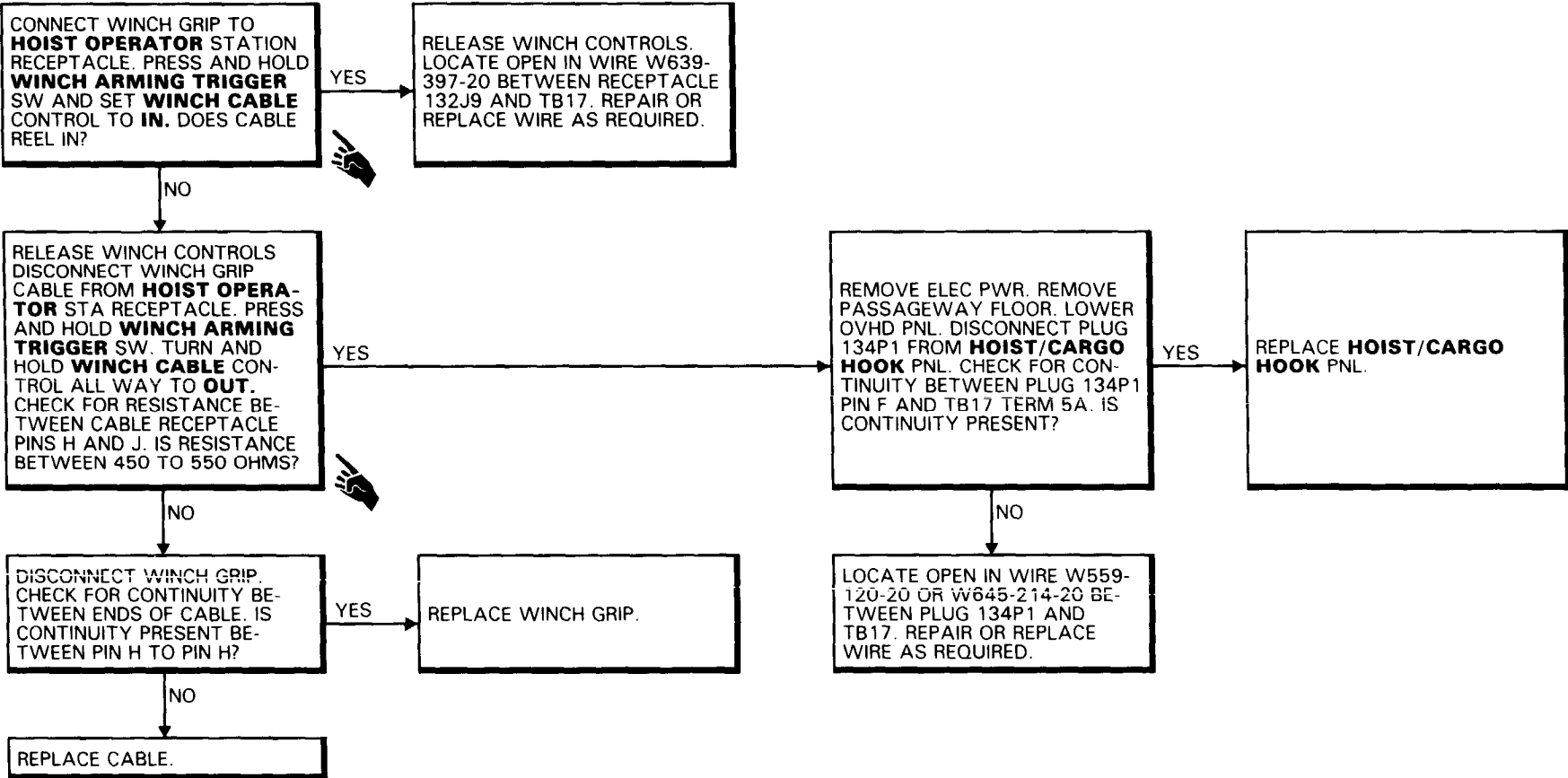

14-1.11 CABLE DOES NOT REEL IN WHEN WINCH IS CONTROLLED BY WINCH GRIP AT STA 502 RECEPTACLE

FAULT ISOLATION PROCEDURE

INITIAL SETUP

Applicable Configurations:
All

Tools:
Electrical Repairer's Tool Kit,
NSN 5180-00-323-4915
Multimeter

Materials:
None

Personnel Required:
68F10 Aircraft Electrician
68F20 Aircraft Electrician

References:
TM 55-1520-240-23

Equipment Condition:
TM 55-1520-240-23:
Battery Connected
Electrical Power On
Hydraulic Power On

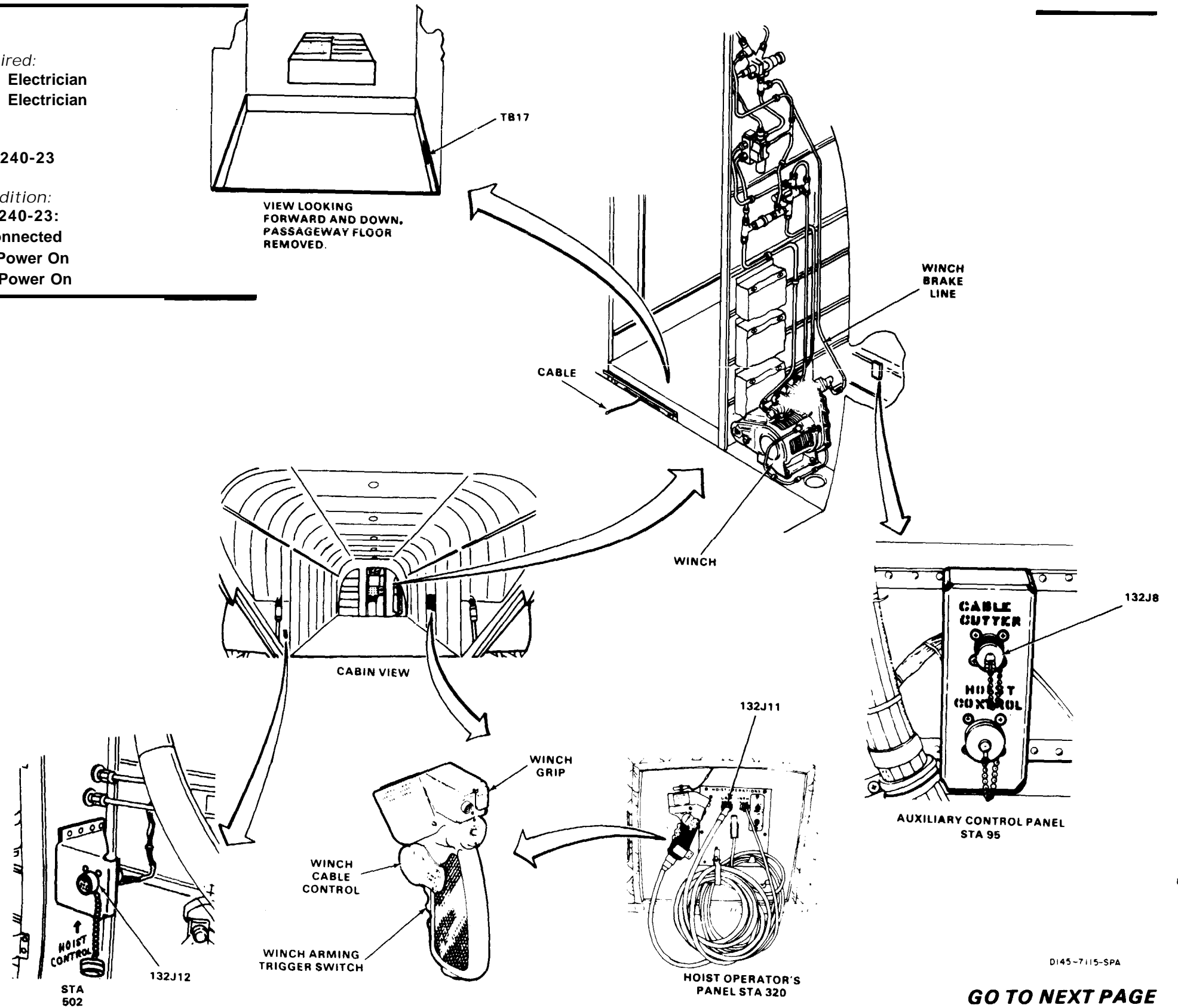

14-1.11 CABLE DOES NOT REEL IN WHEN WINCH IS CONTROLLED BY WINCH GRIP AT STA 502 RECEPTACLE (Continued)

14-1.11

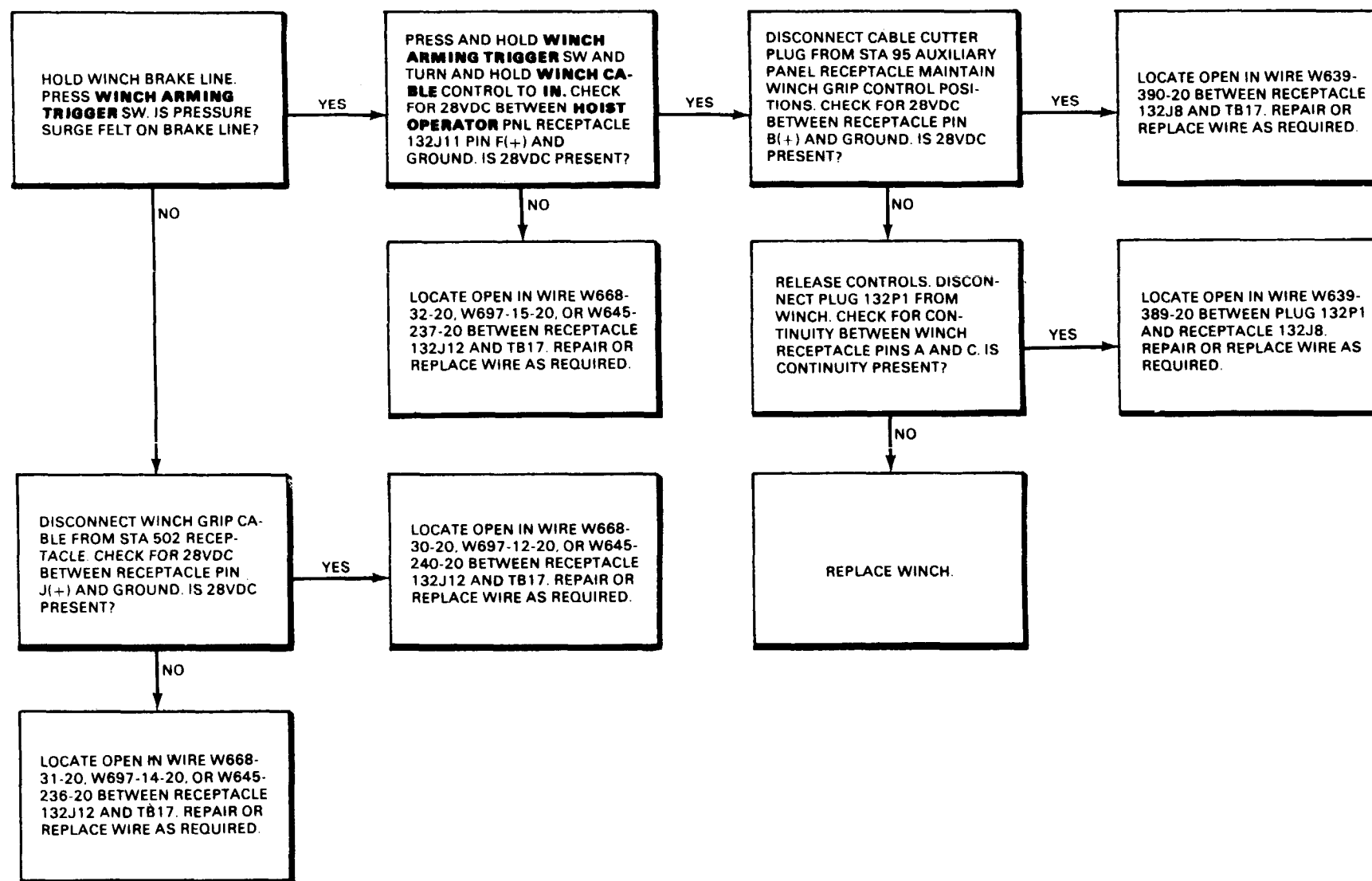

END OF TASK

14-1.12 CABLE DOES NOT REEL OUT WHEN WINCH IS CONTROLLED BY WINCH GRIP AT HOIST OPERATOR STATION

FAULT ISOLATION PROCEDURE

INITIAL SETUP

Applicable Configurations:
All

Tools:
Electrical Repairer's Tool Kit,
NSN 5180-00-323-4915
Multimeter

Materials:
None

Personnel Required:
68F10 Aircraft Electrician
68F20 Aircraft Electrician

References:
TM 55-1520-240-23

Equipment Condition:
TM 55-1520-240-23:
Battery Connected
Electrical Power On
Hydraulic Power On

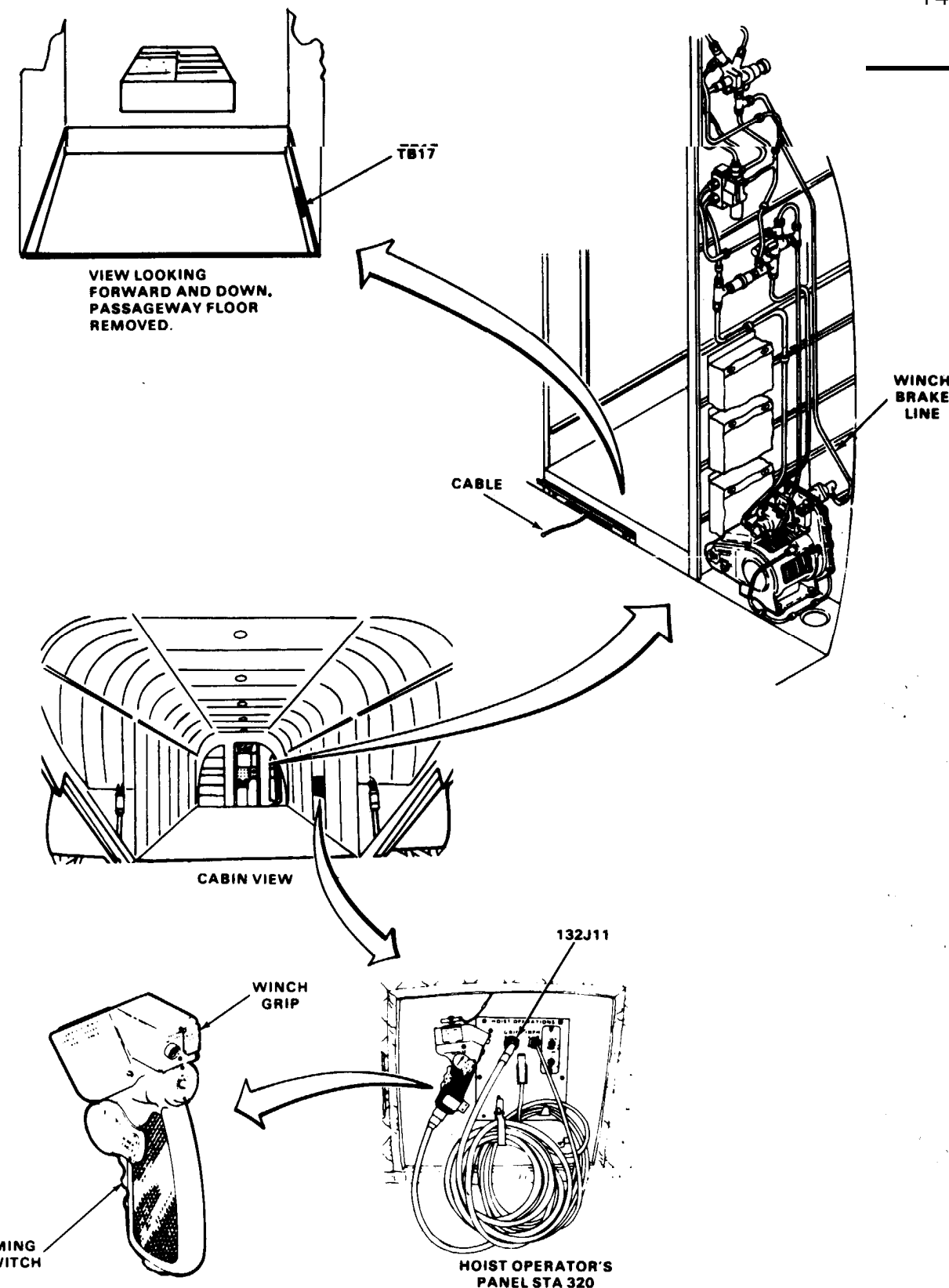
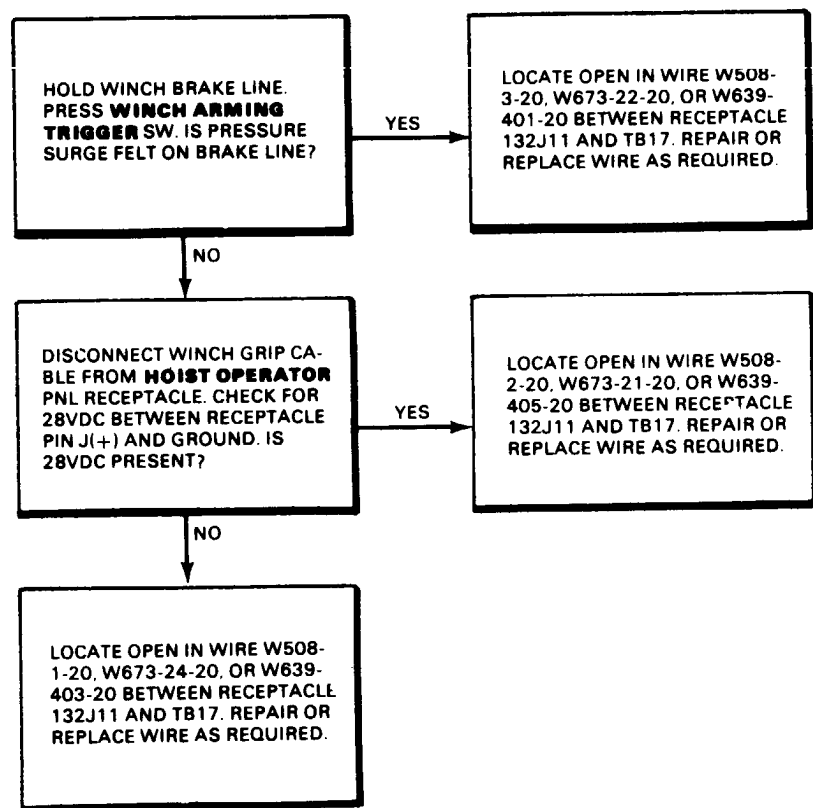

14-1.13 28VDC NOT MEASURED AT STA 340 CABLE CUTTER RECEPTACLE WHEN HOIST/CARGO HOOK PANEL CABLE CUTTER SWITCH SET TO ON

FAULT ISOLATION PROCEDURE

INITIAL SETUP

Applicable Configurations:
All

Tools:
Electrical Repairer's Tool Kit,
NSN 5180-00-323-4915
Multimeter

Materials:
None

Personnel Required:
68F10 Aircraft Electrician
68F20 Aircraft Electrician

References:
TM 55-1520-240-23

Equipment Condition:
TM 55-1520-240-23:
Battery Connected
Electrical Power On
Hydraulic Power On

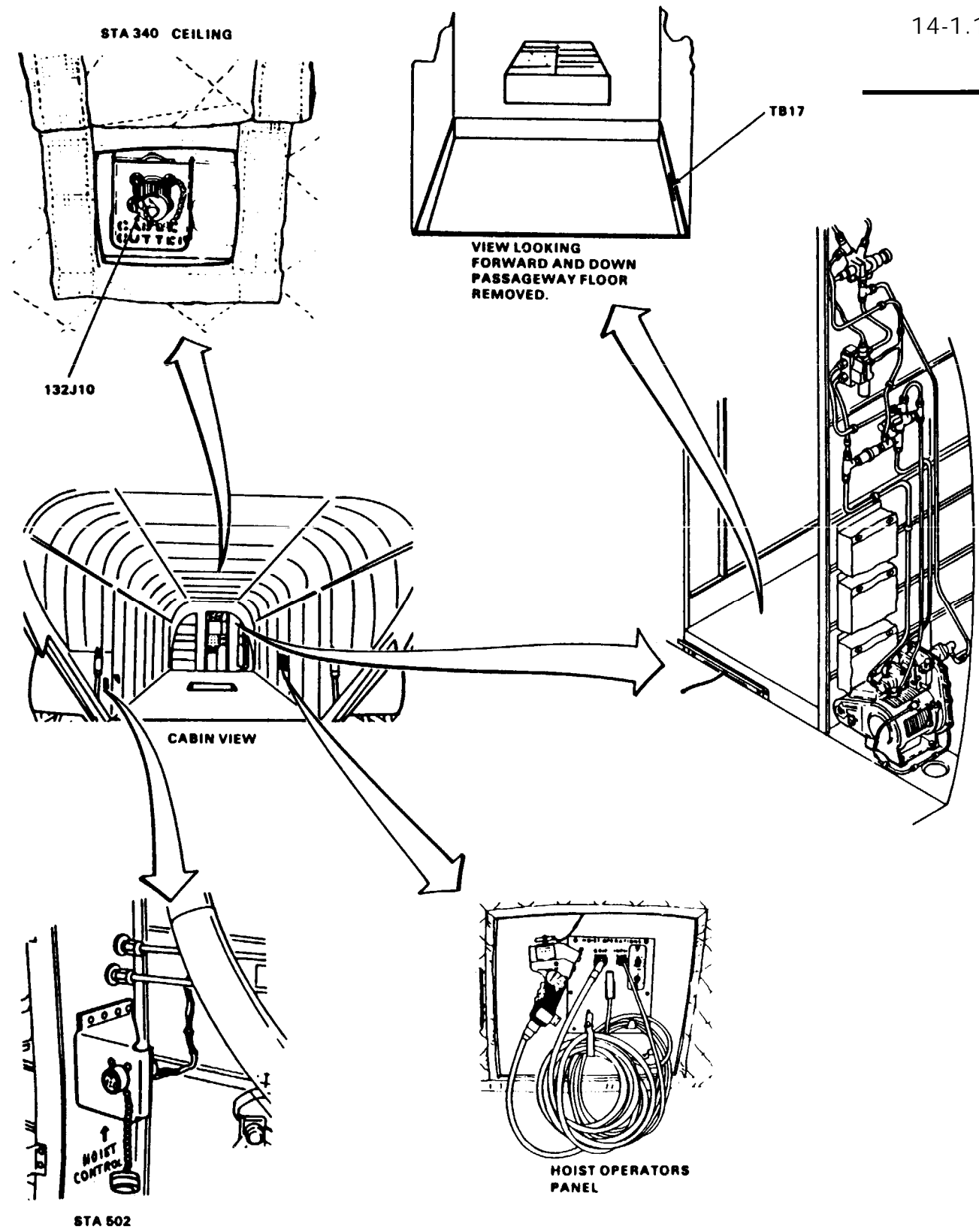
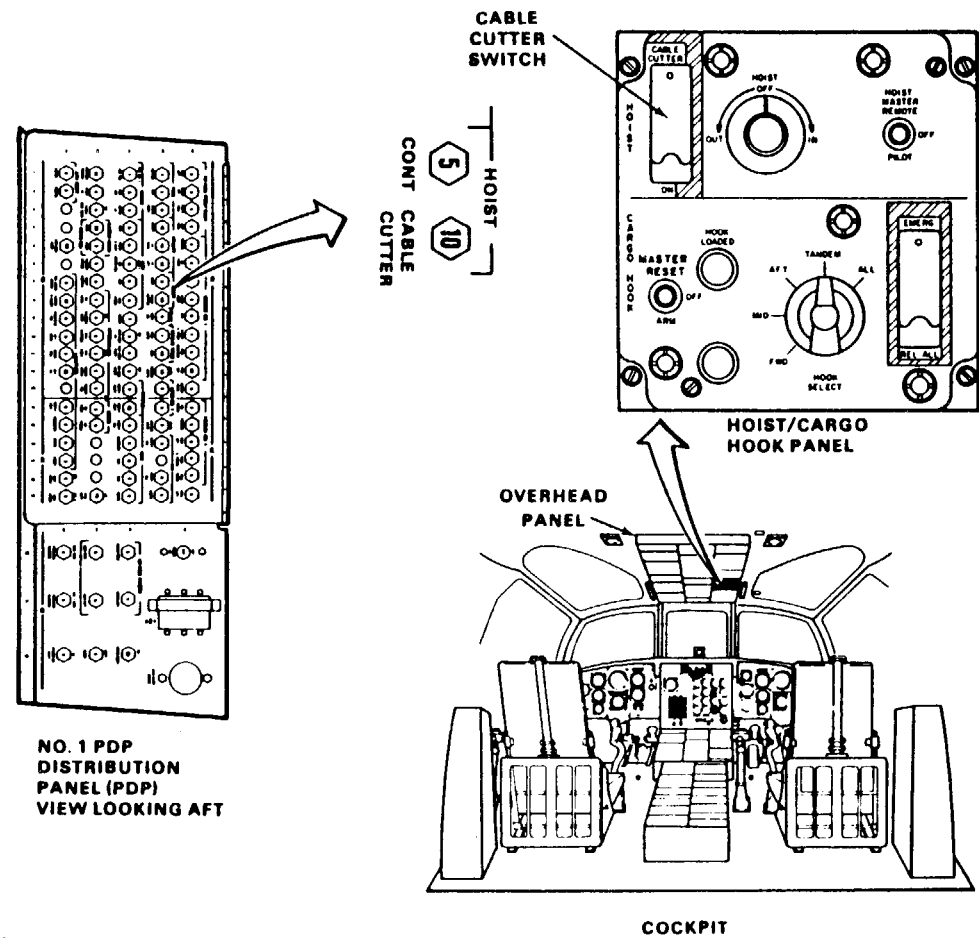

14-1.13 28VDC NOT MEASURED AT STA 340 CABLE CUTTER RECEPTACLE WHEN HOIST/CARGO HOOK PANEL CABLE CUTTER SWITCH SET TO ON (Continued)

14-1.13

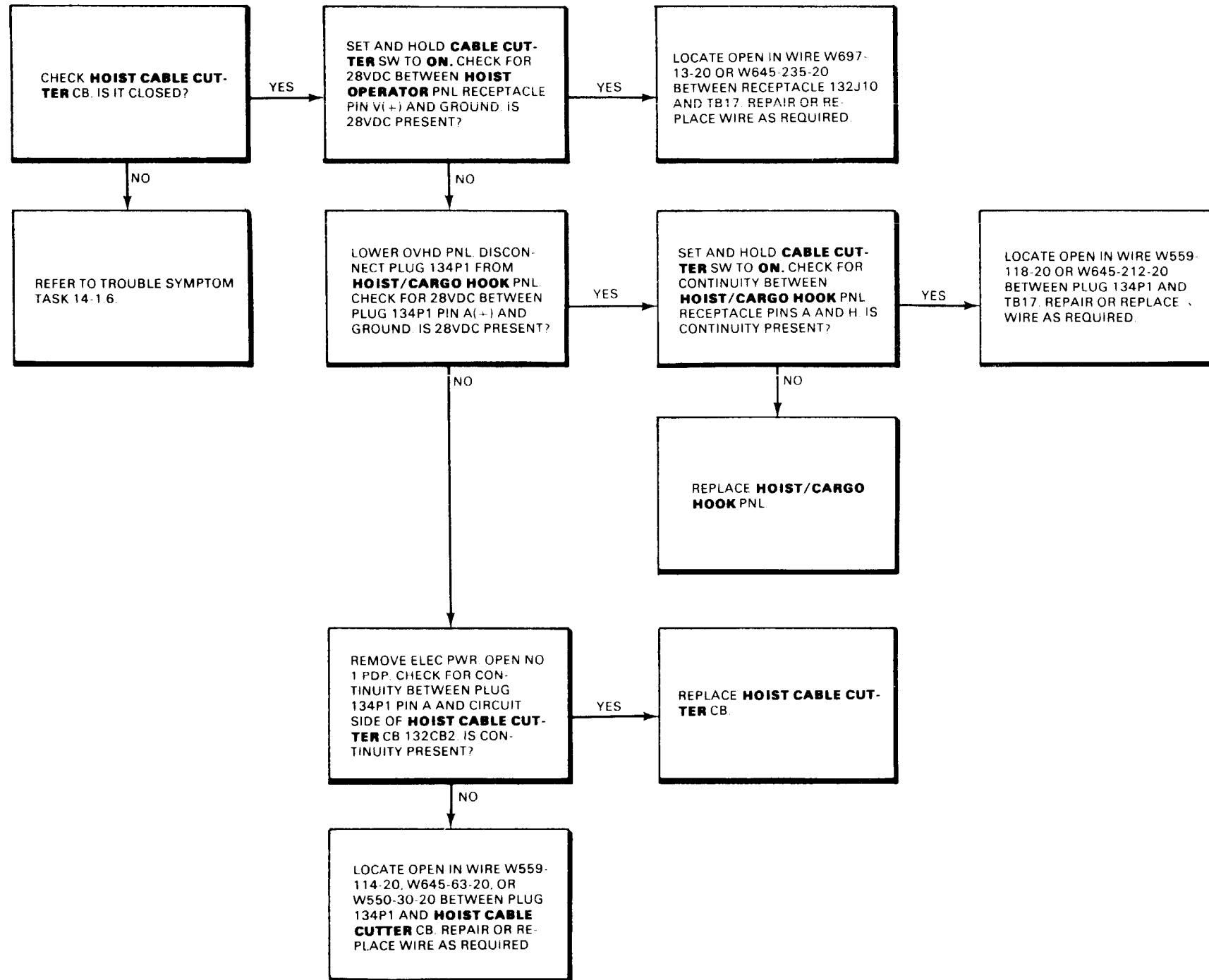

END OF TASK

14-1.14 28VDC NOT MEASURED AT STA340 CABLE CUTTER RECEPTACLE WHEN WINCH GRIP CABLE CUTTER SWITCH PRESSED AT HOIST OPERATOR OR AUXILIARY PANEL

FAULT ISOLATION PROCEDURE

INITIAL SETUP

Applicable Configurations:
All

Tools:
Electrical Repairer's Tool Kit,
NSN 5180-00-323-4915
Multimeter

Materials:
None

Personnel Required:
68F10 Aircraft Electrician
68F20 Aircraft Electrician

References:
TM 55-1520-240-23

Equipment Condition:
TM 55-1520-240-23:
Battery Connected
Electrical Power On
Hydraulic Power Off

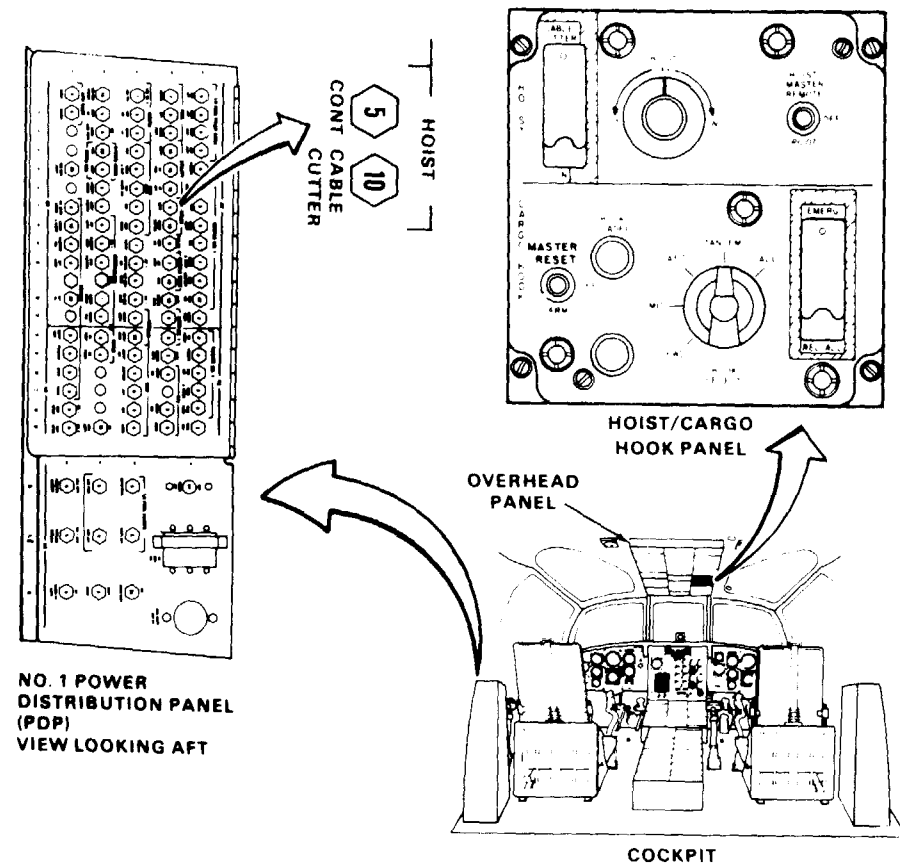
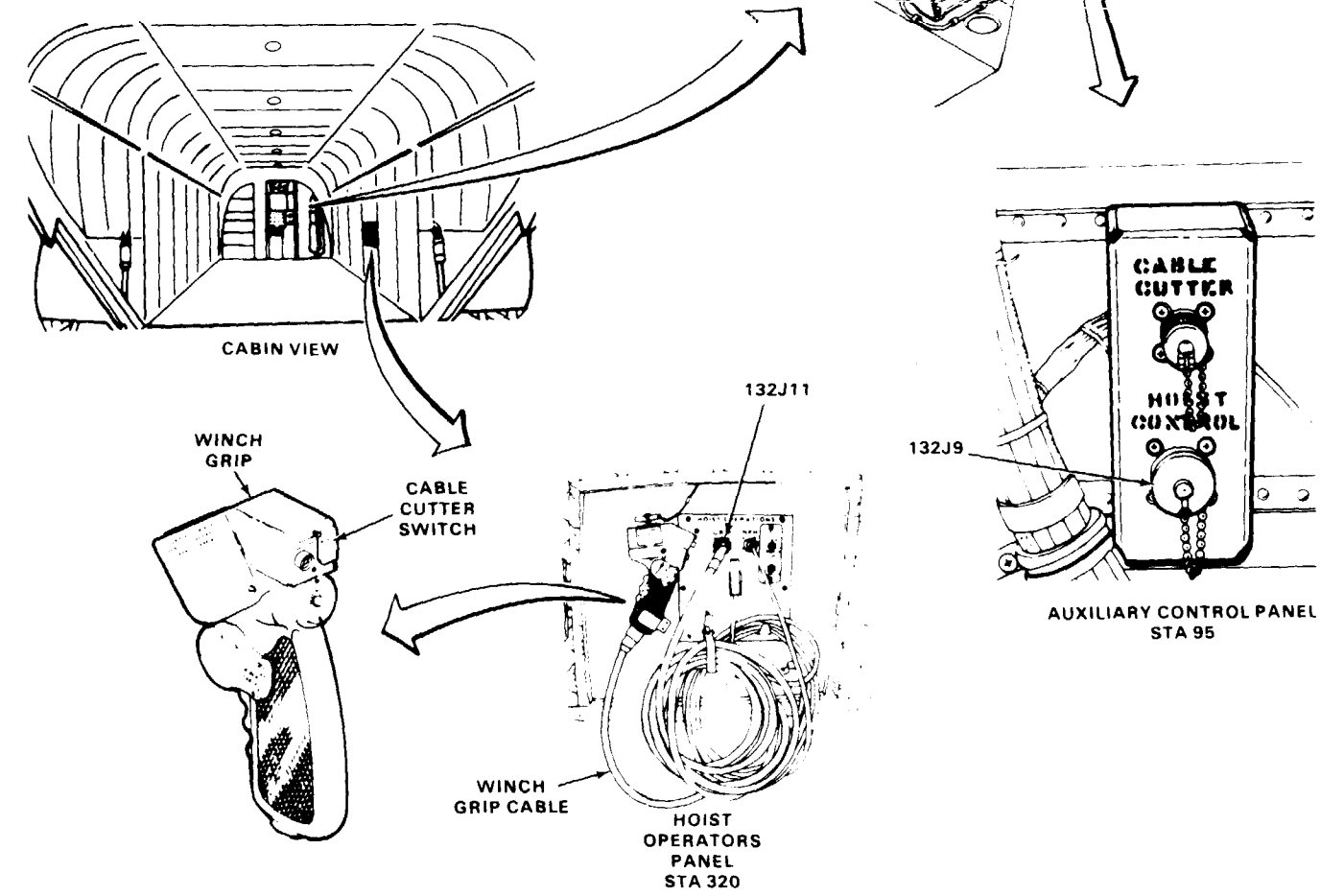
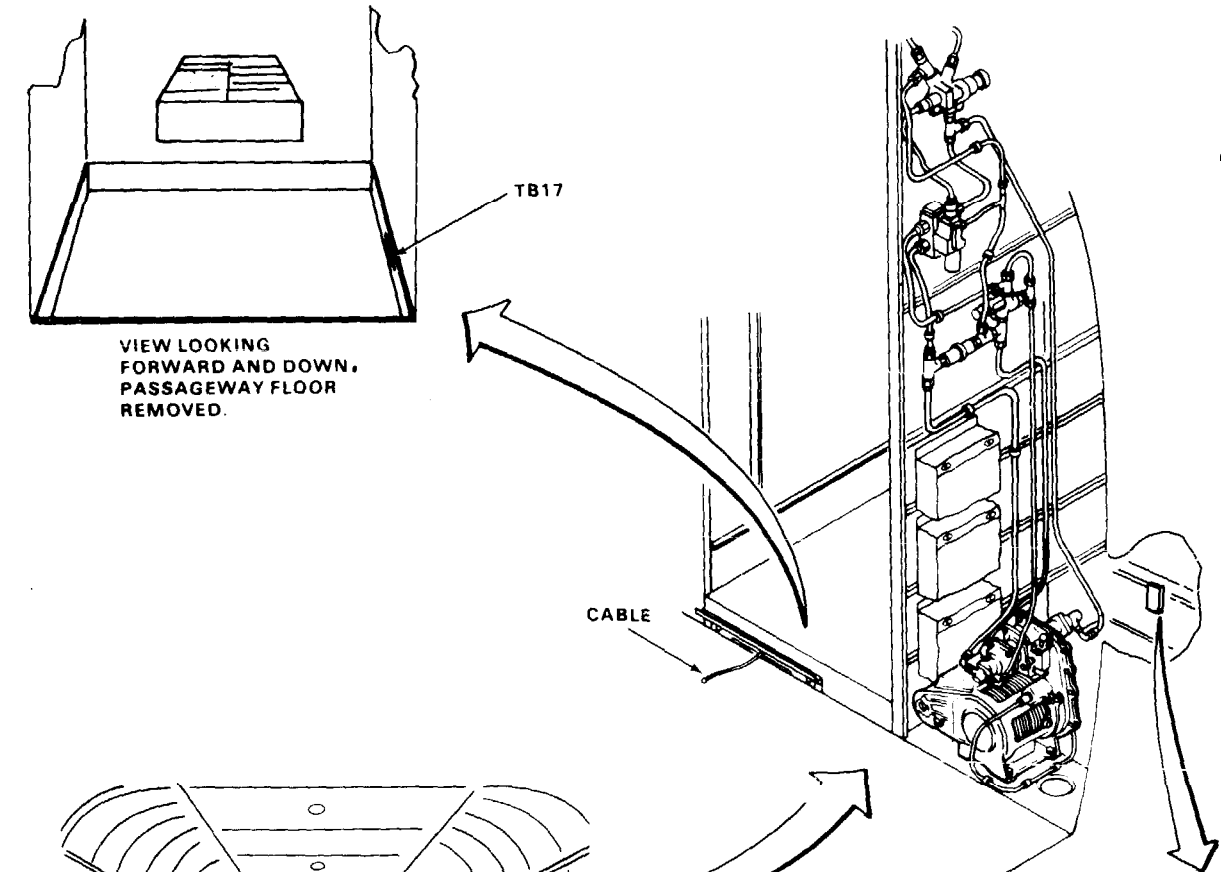

14-1.14 28VDC NOT MEASURED AT STA 340 CABLE CUTTER RECEPTACLE WHEN WINCH GRIP CABLE CUTTER SWITCH PRESSED AT HOIST OPERATOR OR AUXILIARY PANEL (Continued)

14-1.14

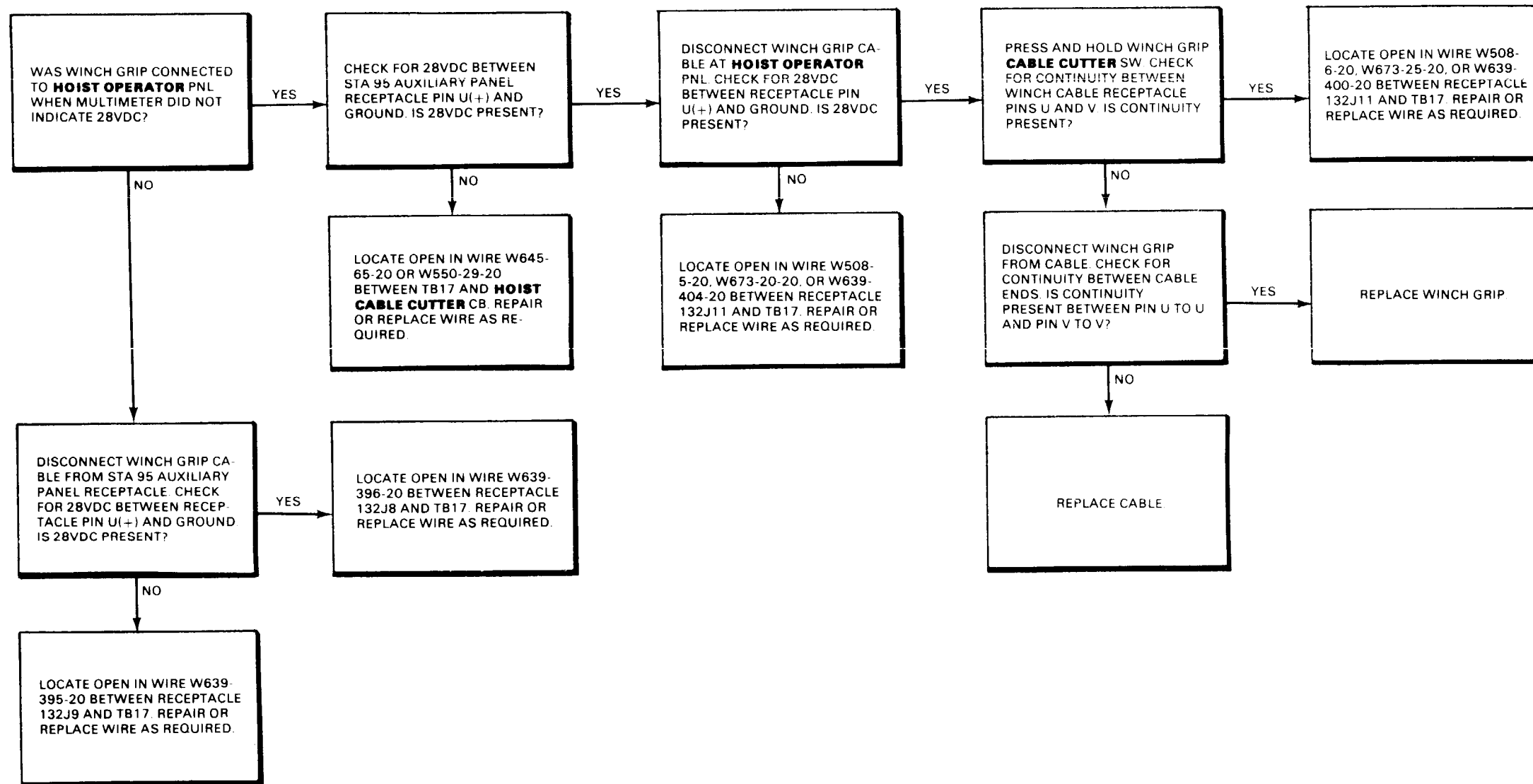

END OF TASK

CHAPTER 15

AUXILIARY POWER UNIT TROUBLESHOOTING

CHAPTER 15
AUXILIARY POWER UNIT SYSTEM TROUBLESHOOTING

CHAPTER OVERVIEW

Chapter 15 contains procedures for Auxiliary Power Unit System troubleshooting. Each system and failure symptom is listed below. Included in this chapter are locations and views of all electrical connectors, receptacles, relays, and ground connections for the Auxiliary Power Unit System.

Refer to TM 55-1520-240-23 for required maintenance procedures.

SYSTEM	PARA
AUXILIARY POWER UNIT	15-1

FAILURE SYMPTOM LIST

AUXILIARY POWER UNIT

SYMPTOM	TASK
APU CONT NORM OR APU CONT EMERG CIRCUIT BREAKER DOES NOT STAY CLOSED	15-1.4
APU DOES NOT MOTOR WHEN APU SWITCH IS SET TO START (WITHOUT 33)	15-1.4
APU DOES NOT MOTOR WHEN APU SWITCH IS SET TO START (WITH 33)	15-1.4
APU HAS HOT START	15-1.4
APU MOTORS BUT DOES NOT START, ESU BITE INDICATES ○●○○	15-1.4
APU MOTORS BUT DOES NOT START, ESU BITE INDICATES ○●●● OR ○○○● THEN ●○○●	15-1.4
APU MOTORS BUT DOES NOT START; ESU BITE INDICATES ○○○● THEN ●○○●	15-1.4

SYMPTOM	TASK
APU ON CAPSULE GOES OUT (APU SHUTS DOWN) WHEN APU CONT CIRCUIT BREAKER OPENED	15-1.4
APU ON CAPSULE OUT WHEN APU OPERATING NORMALLY	15-1.4
APU SHUTS DOWN DURING START, ESU BITE INDICATES ●●○○	15-1.4
APU SHUTS DOWN WHEN APU GEN SWITCH IS SET TO OFF	15-1.4
APU STARTS AND RUNS BUT ESU BITE INDICATES ●○○○	15-1.4

SYMPTOM	TASK
APU STARTS BUT SHUTS DOWN, ESU BITE INDICATES ○○●●	15-1.4
APU STARTS BUT SHUTS DOWN, ESU BITE INDICATES ●●○○	15-1.4
APU STARTS BUT SHUTS DOWN, ESU BITE INDICATES ○●○○	15-1.4
ESU BITE INDICATORS ARE NOT BLACK OR APU FUEL BOOST PUMP CANNOT BE HEARD OPERATING BEFORE APU SWITCH SET TO START	15-1.4

AUXILIARY POWER UNIT SYSTEM ELECTRICAL COMPONENT LOCATION AND CONFIGURATION LIST

REF DESIG	PART NUMBER	TYPE	MATE WITH/LOCATION	STATION LOCATION			REF DESIG	PART NUMBER	TYPE	MATE WITH/LOCATION	STATION LOCATION		
				FS	WL	BL					FS	WL	BL
GD 128		151	LH AFT CABIN	360	32	50L	232P1	MS3476W20-41S	24	CONSOLE-CTK INST PNL MASTER CAUTION PANEL			
GD 129		151	AFT AT APU AREA	594	60	20R	300J1	M83723-74A2041N	40	NO. 1 POP			
GO 130		151	LH AFT TAIL	510	50	45L	300P1	M83723-75A2041N	40	NO. 1 POP			
GO 153		151	LH AFT CABIN	380	-15	50L	300J19	M83723-73A2041N	40	OVERHEAD PANEL-COCKPIT			
TB-3			NO. 1 PDP	90	-15	30L	300P19	M83723-76A2041N	40	OVERHEAD PANEL-COCKPIT			
136K 1	MS24149-D1	106	APU FAULT RELAY	360	32	50L	300J21	M83723-74A2461N	43	OVERHEAD PANEL-COCKPIT			
136P1	M83723-96A1624N	35	J1 OF ESU	520	40	50L	300P21	M83723-75A2461N	43	OVERHEAD PANEL-COCKPIT			
136P2	M83723-95A1415N	34	J2 OF ESU	520	40	50L	300J50	M83723-73A2461N	43	ELECTRONICS COMPART- MENT-OVHD	120	40	20L
136J3	MS3474W12-3S	16	AIRCRAFT SKIN - TANK SIDE-CABLE TO APU FUEL PUMP -LH POD	380	-5	50L	300P50	M83723-76A2461N	43	ELECTRONICS COMPART- MENT-OVHD	120	40	20L
136P4	MS3456W10SL-4S	46	APU FUEL WAVE - LH POD	375	-20	54R	300J54	M83723-74A2461N	43	AFT CROWN	460	50	20L
136P5	M83723-95A1005N	30	APU HYD START VALVE	575	50	30R	300P54	M83723-75A2461N	43	AFT CROWN	460	50	20L
136P6	M83723-95A1624N	35	APU	594	65	8L	300J61	M83723-73A24619	43	CONSOLE - UNDERFLOOR	85	-20	10L
174J5	MS3474W14-19S	21	AIRCRAFT SKIN-INSIDE	385	-5	50L	300P61	M83723-76A24619	43	CONSOLE - UNDERFLOOR	85	-20	10L
174P5	MS3476W14-19P	21	AIRCRAFT SKIN - TANK SIDE	305	-5	50L							

AUXILIARY POWER UNIT SYSTEM ELECTRICAL COMPONENT LOCATION AND CONFIGURATION LIST (Continued)

RECEPTACLE

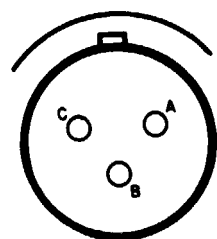

16

PLUG

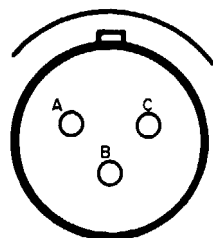

16

RECEPTACLE

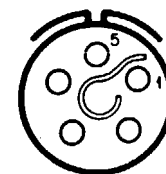

30

PLUG

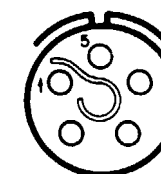

30

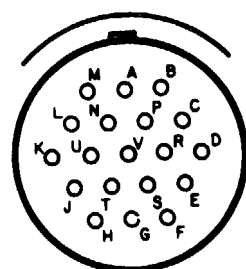

21

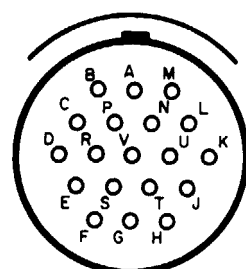

21

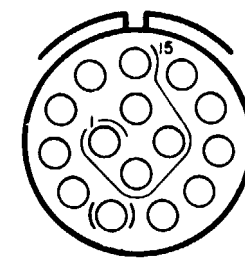

34

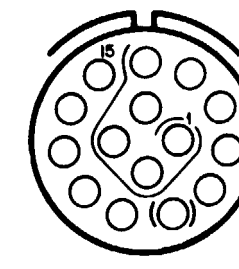

34

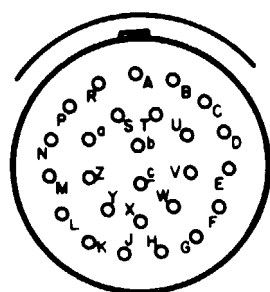

24

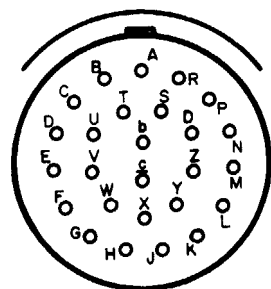

24

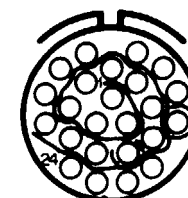

35

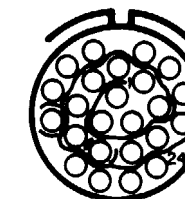

35

AUXILIARY POWER UNIT ELECTRICAL COMPONENT
LOCATION AND CONFIGURATION LIST (Continued)

RECEPTACLE

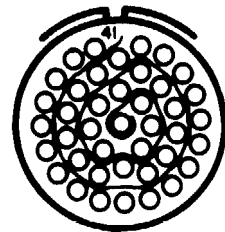

40

PLUG

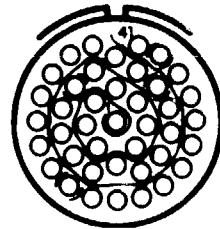

40

RELAY

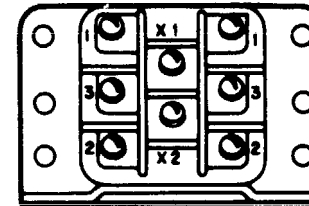

106

GND STUD



151

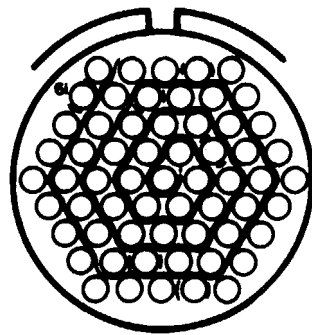

43

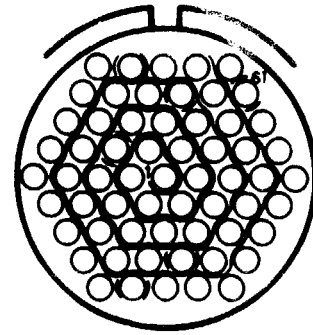

43



46



46

15-1 APU

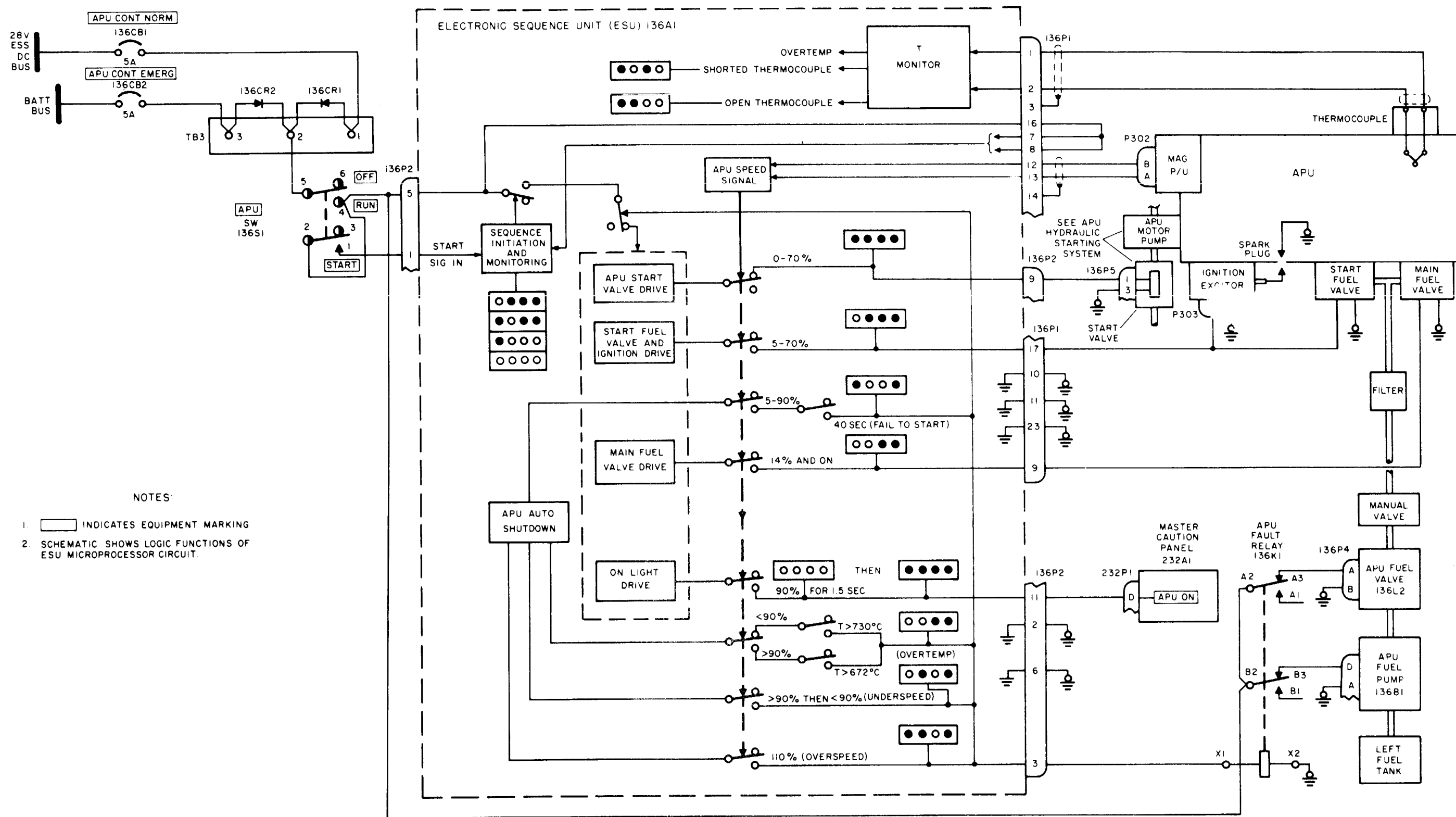

NOTES:

1. INDICATES EQUIPMENT MARKING
2. SCHEMATIC SHOWS LOGIC FUNCTIONS OF ESU MICROPROCESSOR CIRCUIT.

CHAPTER 15

AUXILIARY POWER UNIT SYSTEM TROUBLESHOOTING

CHAPTER OVERVIEW

Chapter 15 contains all procedures for the Auxiliary Power Unit Troubleshooting including the interface to the Main Engine Starter. The Auxiliary Power Unit failure symptoms are listed in Table No. 15-1. Included in this chapter are locations and views of all electrical connectors, receptacles, relays and ground connections for the Auxiliary Power Unit and the interface control systems of the Airframe. Refer to TM 55-1520-240-23 for required maintenance procedures.

DIAGRAMS AND ILLUSTRATIONS

Included in this chapter are block diagrams, illustrations, maintenance tables, schematic diagrams, wiring diagrams, piping diagrams and troubleshooting logic trees which are necessary to troubleshoot the APU system components including the interface to the Main Engine Starter components. All APU systems troubleshooting instructions are contained in this chapter and are listed in the seven (7) groups described in the order listed below. The application of the APU Field Tester is described in paragraph 15-7.

APU SYSTEMS MAJOR TITLES	PARA.	VISUAL CHECKS	PARA.	OPERATIONAL CHECKS	PARA.
APU TO AIRFRAME INTERFACE	15-1	APU VISUAL	15-1.4	APU NORMAL OPERATION	15-1.5
APU ELECTRICAL SYSTEM	15-2	APU HYDRAULIC	15-4.7	APU - HYDRAULIC STARTING	15-4.8
APU FUEL SYSTEM	15-3	ENGINE HYDRAULIC	15-5.4	ENGINE - HYDRAULIC STARTING	15-5.5
APU HYDRAULIC SYSTEM	15-4			APU TESTER OPERATION	15-7.3
APU / ENGINE HYDRAULIC STARTER	15-5				
APU MICROPROCESSOR ELECTRONIC SEQUENCE UNIT (ESU)	15-6				
APU TESTER	15-7				

TEM NO.	SYMPTOM	APPLICABLE SYSTEM	TASK
1	APU DOES NOT MOTOR		
	APU DOES NOT MOTOR	ELECTRICAL	15-2.10
	APU DOES NOT MOTOR, ESU BITE INDICATES ○●●●	ELECTRICAL	15-2.10
	APU DOES NOT MOTOR, ESU BITE INDICATES ●○○●	ELECTRICAL	15-2.10
	APU DOES NOT MOTOR, ESU BITE INDICATES ●○○○	ELECTRICAL	15-2.10
	APU DOES NOT MOTOR, ESU BITE INDICATES ○○○○	ELECTRICAL	15-2.10
	APU DOES NOT MOTOR	HYDRAULIC	15-4.10

ITEM NO.	SYMPTOM	APPLICABLE SYSTEM	TASK
2	APU MOTORS BUT DOES NOT START APU MOTORS BUT DOES NOT START, ESU BITE INDICATES ○○●● THEN ●○○●	FUEL - (APU)	15-3.6
	APU MOTORS BUT DOES NOT START, ESU BITE INDICATES ○○○● THEN ●○○●	FUEL - (APU)	15-3.7
	APU MOTORS BUT DOES NOT START, ESU BITE INDICATES ○●●● OR ○○○● THEN ●○○●	HYDRAULIC	15-4.11
	APU MOTORS BUT DOES NOT START, ESU BITE INDICATES ○●○○	ELECTRONIC	15-6.11
	APU MOTORS BUT DOES NOT START, ESU BITE INDICATES ○●●● OR ○○○● THEN ●○○●	ELECTRONIC	15-6.12
	APU MOTORS BUT DOES NOT START, ESU BITE INDICATES ○○○● THEN ●○○●	ELECTRONIC	15-6.13

TABLE 15-1 APU COMPOSITE FAILURE SYMPTOM LIST (Continued)			
ITEM NO.	SYMPTOM	APPLICABLE SYSTEM	TASK
3	APU STARTS BUT SHUTS DOWN APU STARTS BUT SHUTS DOWN, ESU BITE INDICATES ○○○○ THEN ●●○○	ELECTRONIC	15-6.14
	APU STARTS BUT SHUTS DOWN, ESU BITE INDICATES ○○○● THEN ○●○○	ELECTRONIC	15-6.15
	APU STARTS BUT SHUTS DOWN, ESU BITE INDICATES ○○○● THEN ○○●●	ELECTRONIC	15-6.16
	APU STARTS BUT SHUTS DOWN, ESU BITE INDICATES ○○●● THEN ●●○○	ELECTRONIC	15-6.18
4	APU STARTS AND RUNS APU STARTS AND RUNS THEN SHUTS DOWN, ESU BITE INDICATES ○○○○ THEN ○○●●	ELECTRONIC	15-6.17
	APU STARTS AND RUNS BUT ESU BITE INDICATES ●○○○	ELECTRONIC	15-6.19
5	APU SHUTS DOWN APU SHUTS DOWN WHEN GEN APU SWITCH PLACED TO ON ESU BITE INDICATES ●●●●	ELECTRICAL	15-2.14
	APU SHUTS DOWN WHEN APU GEN SWITCH IS SET TO OFF	ELECTRICAL	15-2.15
6	APU CIRCUIT BREAKERS APU CONT NORM OR APU CONT EMERG CIRCUIT BREAKER DOES NOT STAY CLOSED	ELECTRICAL	15-2.7
7	ESU BITE INDICATORS ESU BITE INDICATORS DO NOT CYCLE AFTER APU SWITCH SET TO RUN	ELECTRICAL	15-2.8

TABLE 15-1 APU COMPOSITE FAILURE SYMPTOM LIST (Continued)			
ITEM NO.	SYMPTOM	APPLICABLE SYSTEM	TASK
8	APU FUEL BOOST PUMP APU FUEL BOOST PUMP CANNOT BE HEARD OPERATING BEFORE APU SWITCH SET TO START	ELECTRICAL	15-2.9
9	APU ON CAPSULE GOES OUT APU ON CAPSULE GOES OUT (APU SHUTS DOWN) WHEN APU CONT CIRCUIT BREAKER OPENED	ELECTRICAL	15-211
	APU ON CASULE OUT WHEN APU OPERATING NORMALLY	ELECTRICAL	15-2.13
10	APU DOES NOT STOP APU DOES NOT STOP, ESU INDICATORS ARE BLACK ●●●●	ELECTRICAL	15-2.12
11	APU PUMP FAULT LIGHT APU PUMP FAULT LIGHT IS ON	HYDRAULIC	15-4.12
12	NO. 1 OR NO. 2 ENGINE DOES NOT MOTOR NO 1 OR NO 2 ENGINE DOES NOT MOTOR (HYDRAULIC SYSTEM)	HYDRAULIC	15-5.6
13	NO. 1 OR NO. 2 ENGINE KEEPS MOTORING NO 1 OR NO 2 ENGINE KEEPS MOTORING WHEN ENGINE START SWITCH SET TO OFF	HYDRAULIC	15-5.7
14	APU START ACCUMULATOR GAGE APU START ACCUMULATOR GAGE DOES NOT INDICATE AT LEAST 2850 PSI	HYDRAULIC	15-4.9

15-1 APU TO AIRFRAME INTERFACE

PARAGRAPH 15-1

TABLE OF CONTENTS

APU TO AIRFRAME INTERFACE TROUBLESHOOTING

PARAGRAPH	DESCRIPTION	FUNCTION	PAGE
15-1	APU TO AIRFRAME INTERFACE		15-5
15-1.1	APU SYSTEM COMPONENTS	DRAWING	15-8
15-1.2	OVERALL ELECTRICAL CABLING INTER- CONNECTIONS OF APU SYSTEM COMPONENTS, "INTERFACED" TO MAIN ENGINE "STARTER" COMPONENTS	DRAWING	15-10
15-1.3	OVERALL PIPING INTERRELATIONSHIP OF APU SYSTEM COMPONENTS, "INTERFACED" TO MAIN ENGINE "STARTER" COMPONENTS	DRAWING	15-13
15-1.4	APU VISUAL CHECK	TASK	15-14
15-1.5	APU OPERATIONAL CHECK	TASK	15-16

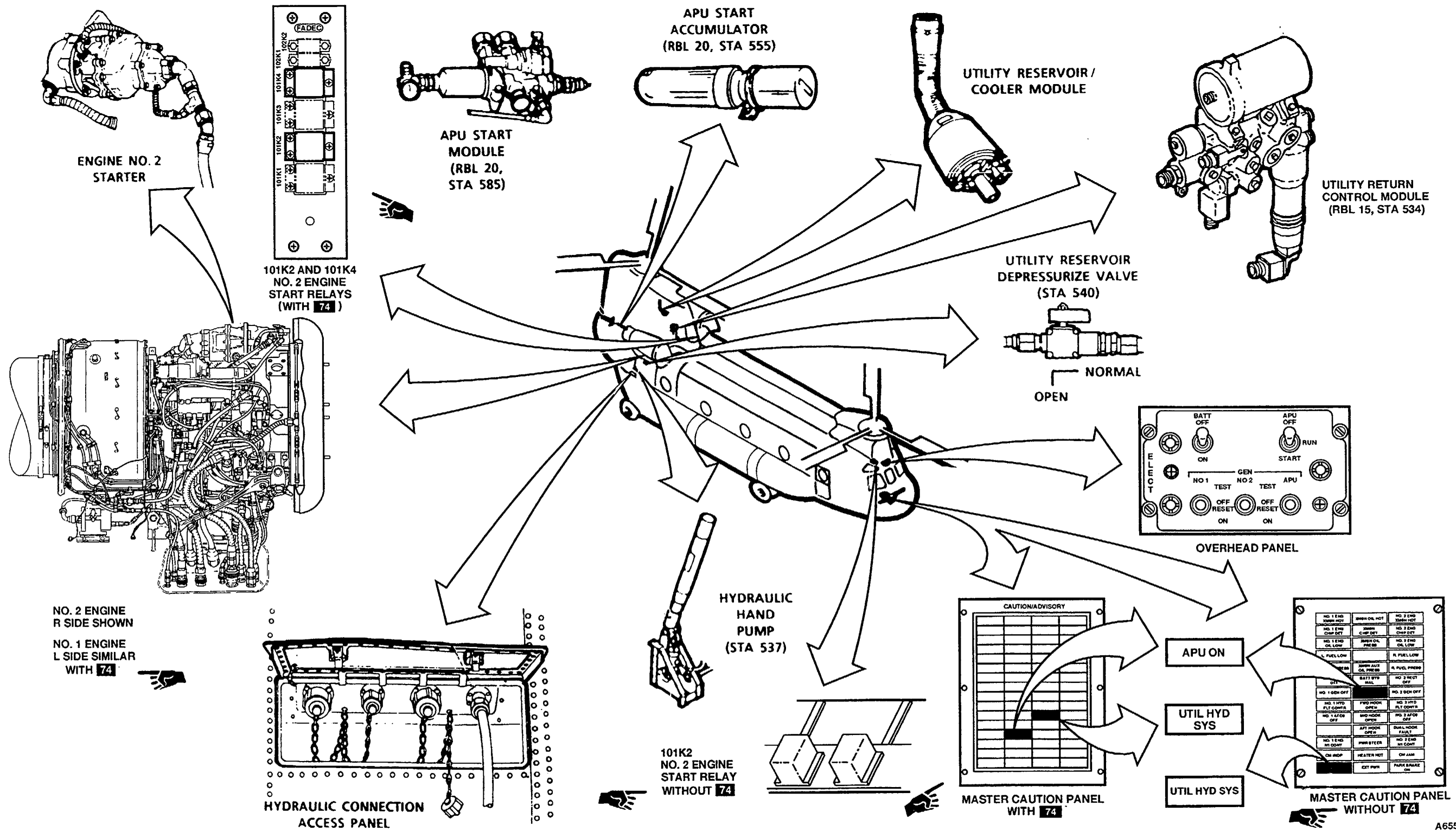

A65541

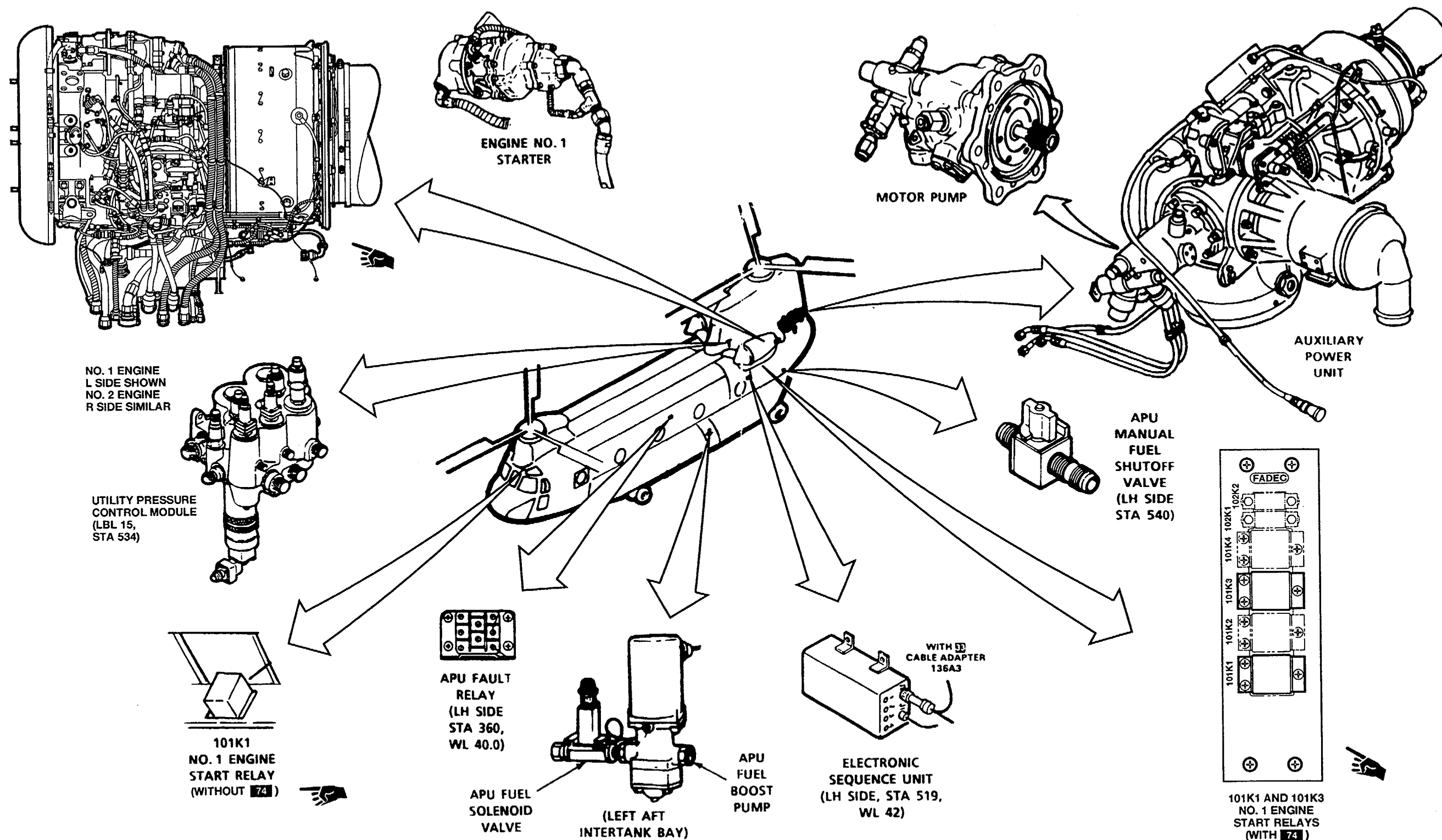

A72500

COCKPIT SECTION WITHOUT 74

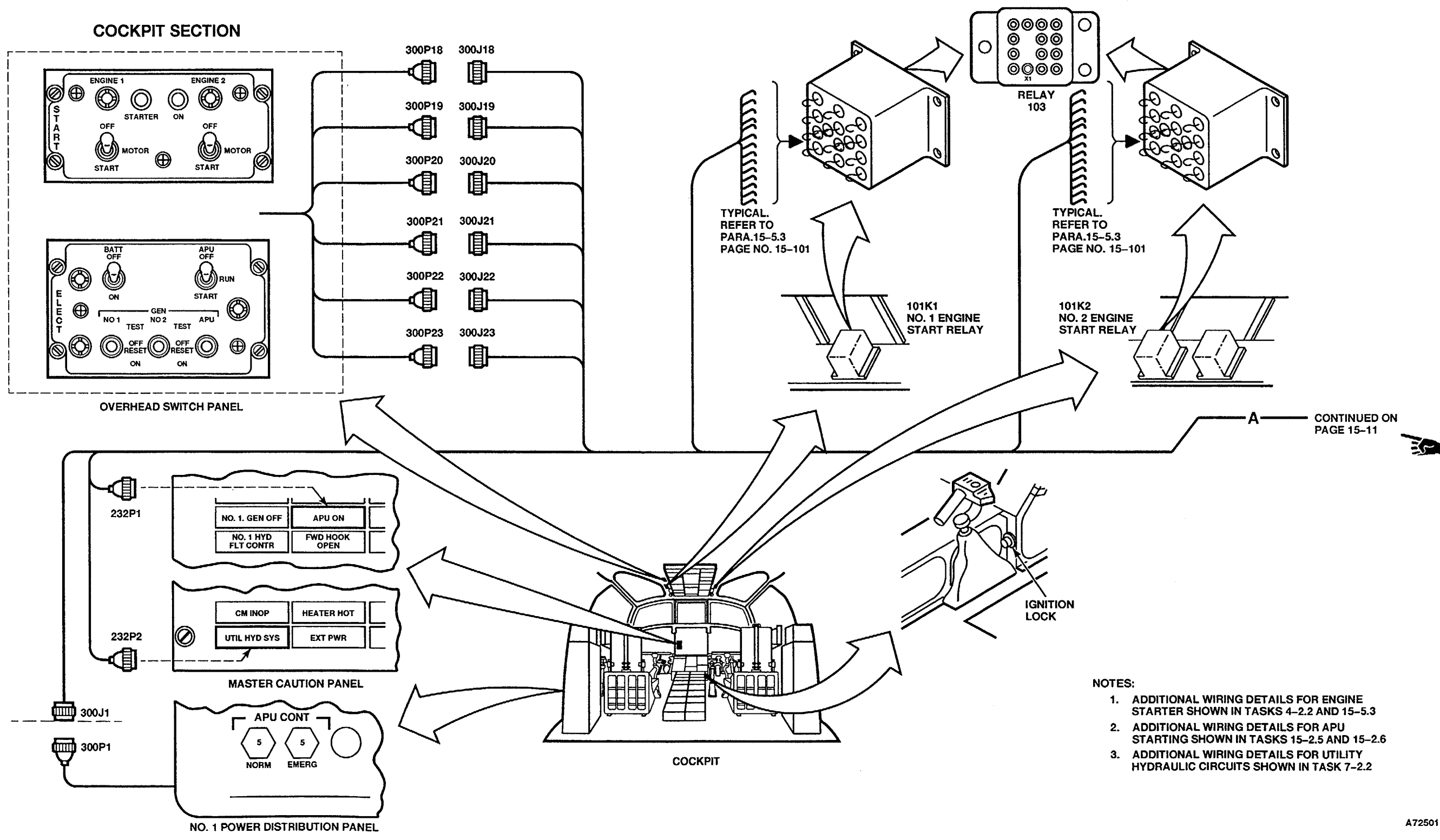

COCKPIT SECTION WITH 74

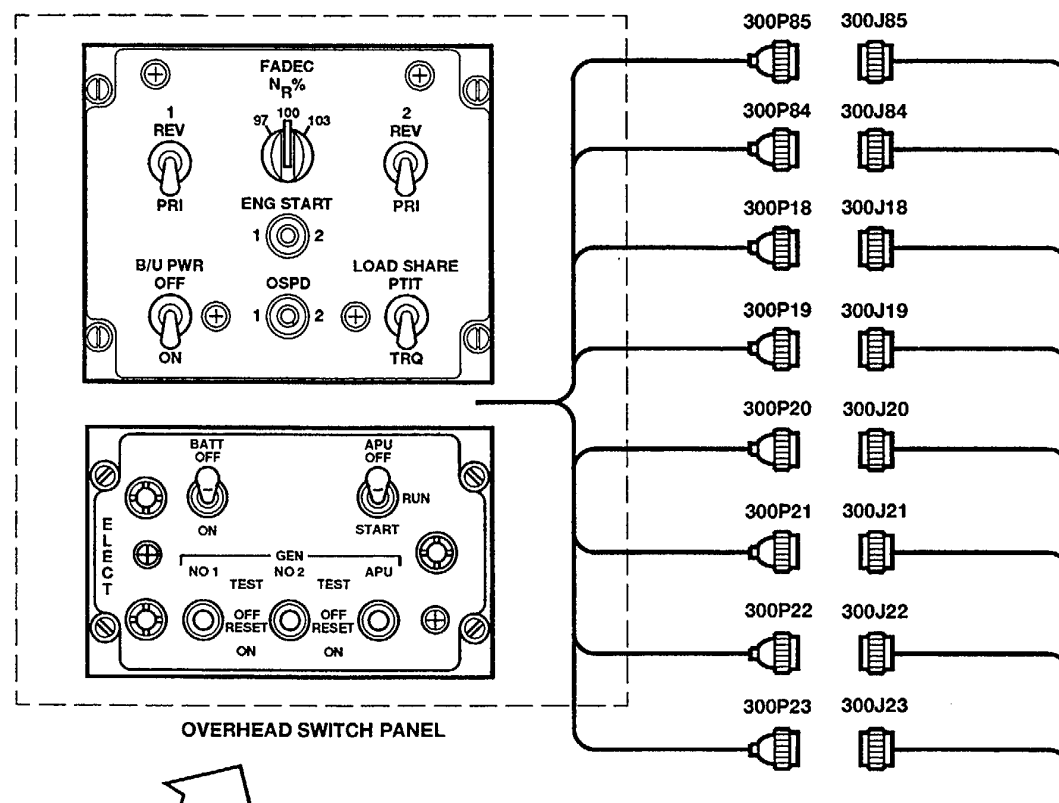

B CONTINUED ON PAGE 15-10.2

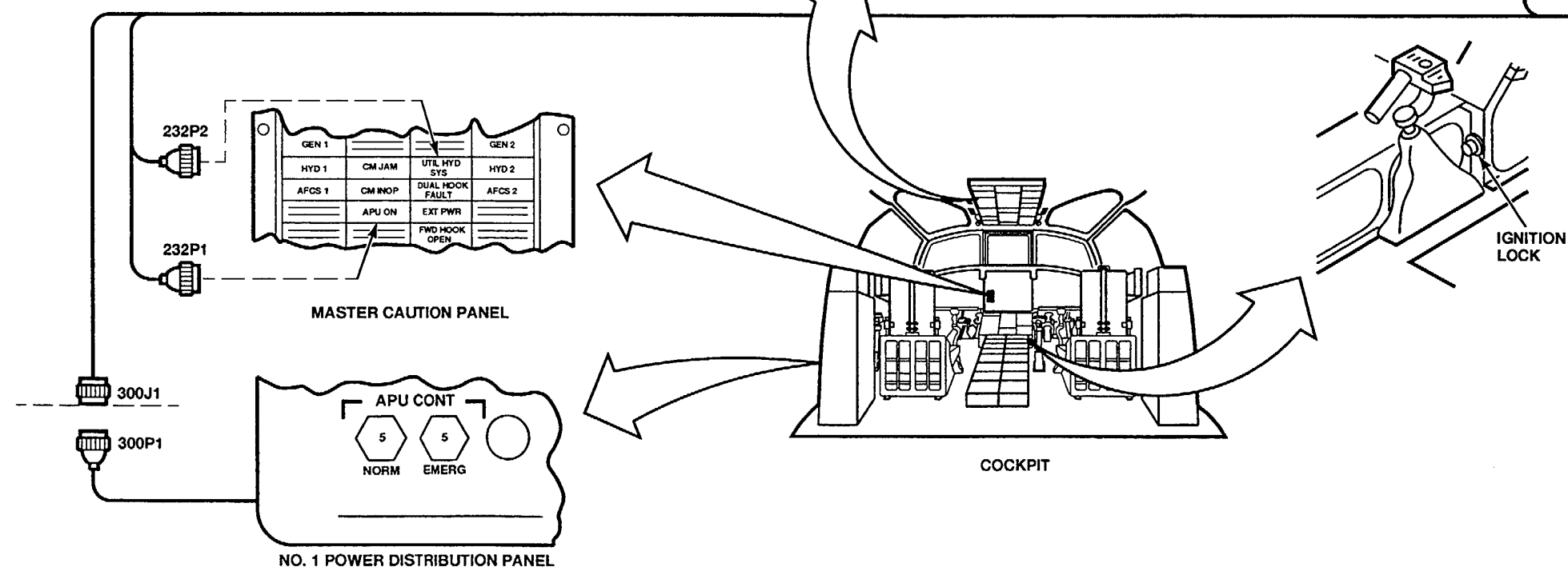

- NOTES:
1. ADDITIONAL WIRING DETAILS FOR ENGINE STARTER SHOWN IN TASKS 4-10.2 AND 15-5.3
 2. ADDITIONAL WIRING DETAILS FOR APU STARTING SHOWN IN TASKS 15-2.5 AND 15-2.6
 3. ADDITIONAL WIRING DETAILS FOR UTILITY HYDRAULIC CIRCUITS SHOWN IN TASK 7-2.2

A65579

GO TO NEXT PAGE

Change 23 15-10.1

AIRFRAME SECTION WITH 74

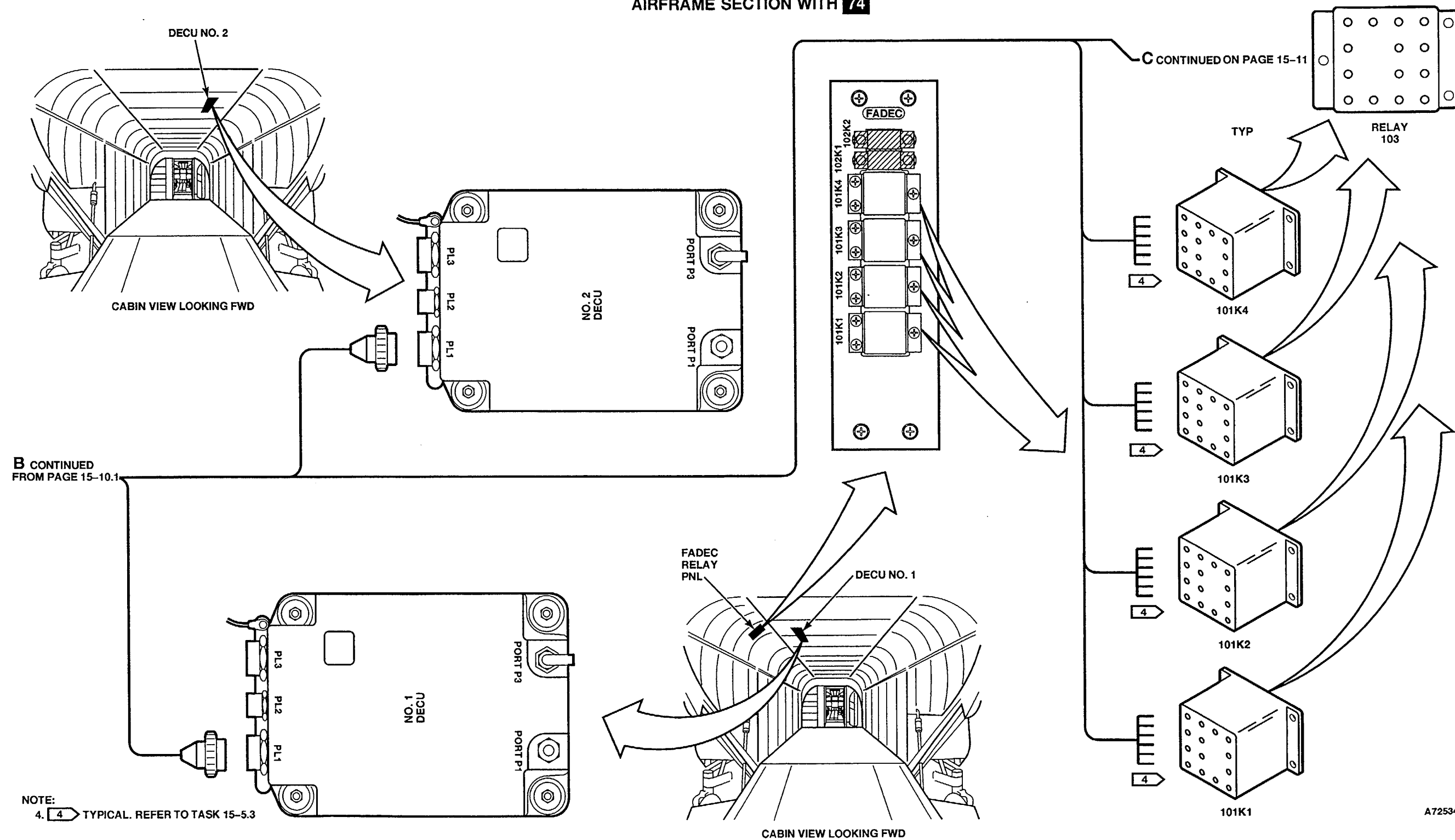

AIRFRAME SECTION WITHOUT 74

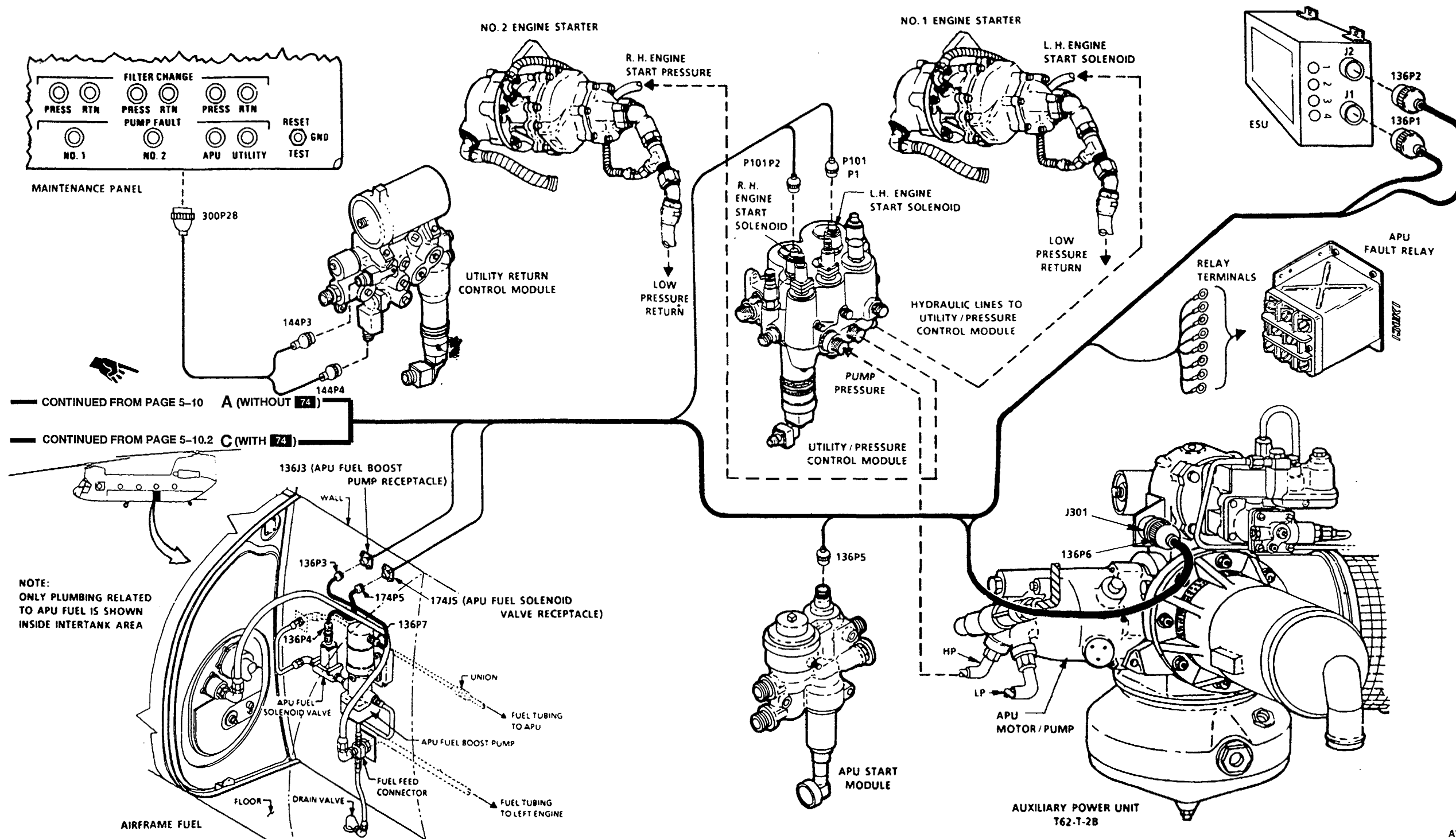

A72533

A. OVERVIEW - OF APU **INTERFACED** TO MAIN ENGINE STARTERS

The APU **interfaced** to the Main Engine Starters includes the activation of the following components and interconnections as shown in paragraph 15-1.2.

1. Hydraulic STARTERS on each engine
2. Engine START valves
3. Solenoid-operated pilot valves on the Utility System Pressure Control Modules
4. Start switches and relays
5. Caution lights
6. Ignition LOCK switch
7. Start Fuel Solenoid Valve
8. APU Fuel Solenoid Valve
9. APU Fuel Boost Pump
10. APU Electronic Sequence Unit (ESU)
11. APU FAULT RELAY
12. APU Ignition Exciter
13. APU T62-T-2B Engine

B. BRIEF OPERATIONAL DESCRIPTION OF MAIN ENGINE START SYSTEM

On helicopters without **74**, when the Main Engine **START** switch is moved to **MOTOR**, the STARTER ON caution light comes "ON" and the Engine Start valve "OPENS". The START VALVE applies UTILITY SYSTEM PRESSURE from the **APU** to the Main Engine starter, thus rotating the Engine Starter and Compressor.

On helicopters with **74**, when the main **ENG START** switch is set to **1** or **2**, the engine start valve "OPENS". The START VALVE applies UTILITY SYSTEM PRESSURE from the **APU** to the Main Engine starter, thus rotating the Engine Starter and Compressor.

NOTE

For additional information, refer to task 15-5.5 - **ENGINE Hydraulic Starting System Operational Check** and tasks 4.4 - **Engine Start and Ignition System (Without **74**)** or 4.10- **Engine Start and Ignition System (With **74**)**.

C. BRIEF OPERATIONAL DESCRIPTION OF **APU SYSTEM**

The Gas Turbine Auxiliary Power Unit T62-T-2B (APU) is mounted in the aft cabin above the ramp. The basic components of the APU are the gas turbine engine, hydraulic motor-pump, fuel control, accessory drive, and ac generator. An APU control box, ESU, which monitors APU operation is on the left side of the cabin above the ramp. The motor-pump on the APU pressurizes the utility and flight control hydraulic systems for main engine starting and ground checks. The APU also drives an ac generator which supplies power to No. 1 and No. 2 electrical systems. The APU receives fuel from the left fuel system thru a booster pump, a manual fuel shutoff valve, and a solenoid valve.

The APU control switch is on the electrical power panel on the overhead switch panel. It is a three-position switch marked APU OFF, RUN, and START. The switch is spring loaded from RUN to START. To start the APU, the switch is moved from OFF to RUN for 3 to 5 seconds, then set to START for 2 seconds, then released to RUN. APU start is then automatic and controlled by the control box. The APU ON caution light will come on in about 10 to 12 seconds.

NOTE

For additional information, refer to task 15-1.5, **APU Operational Check**.

15-1.3 OVERALL PIPING INTERRELATIONSHIP OF APU SYSTEM COMPONENTS, "INTERFACED" TO MAIN ENGINE STARTER COMPONENTS

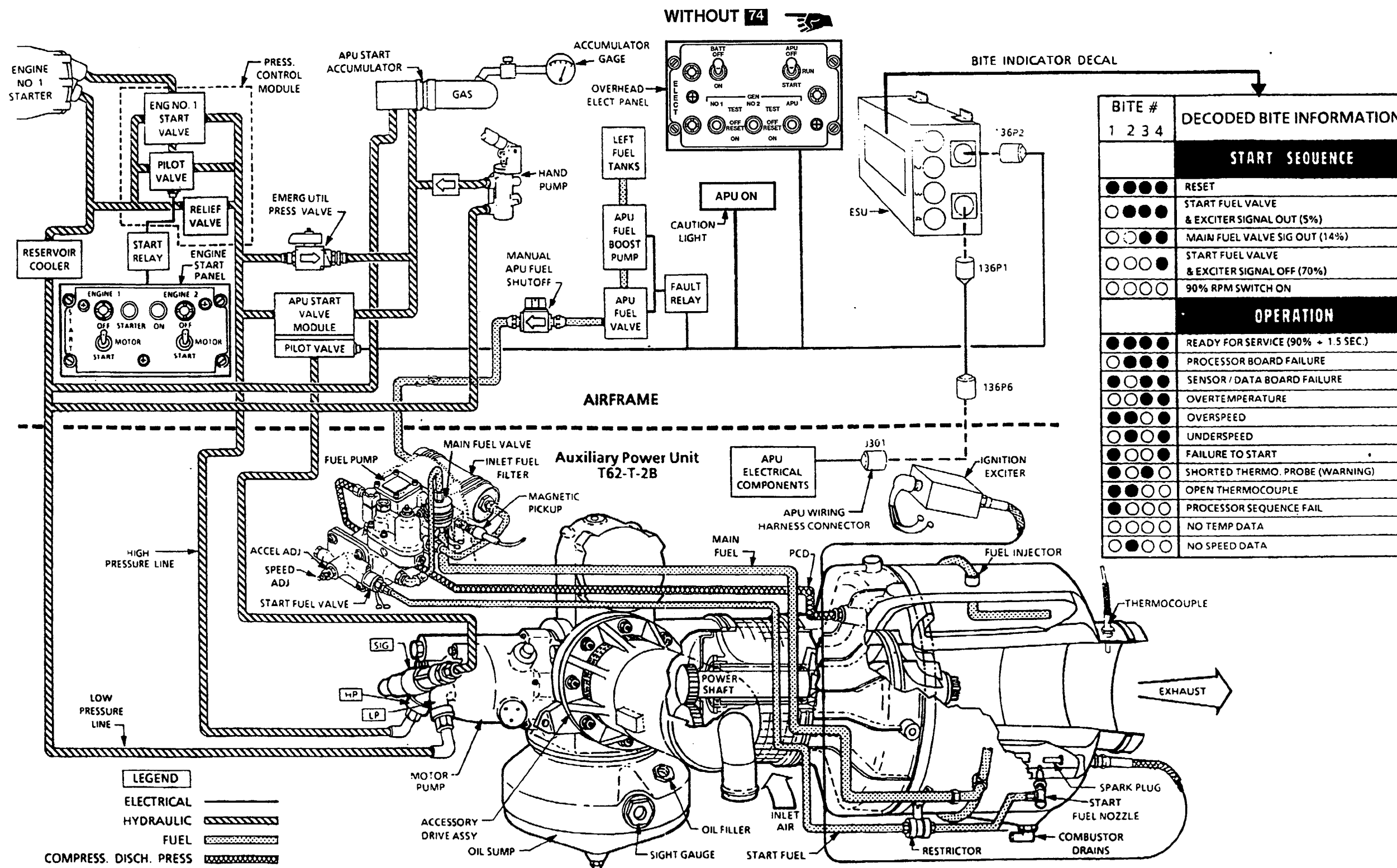

A72506

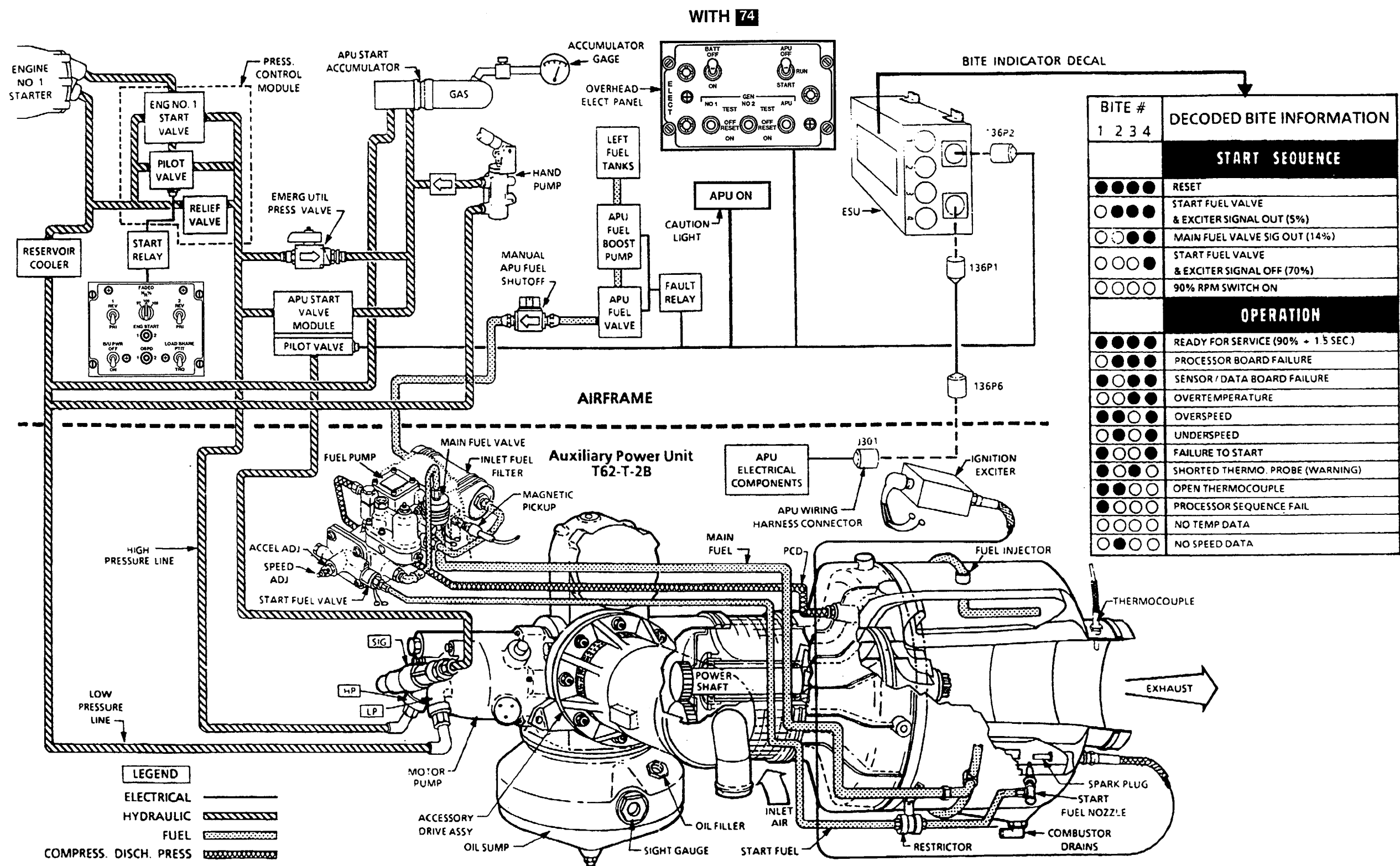

A72503

15-1.4 APU VISUAL CHECK

INITIAL SETUP

Applicable Configurations:
All **Equipment Condition:**

Tools:
Aircraft Mechanic's Tool Kit.
NSN 5180-00-323-4692
Work Stand

Materials:
None
Personnel Required:
Medium Helicopter Repairer

References:
TM 55-1520-240-23

TM 55-1520-240-23:
Battery Disconnected
Ext Electrical Power Off
Ext Hydraulic Power Off
Left Aft Intertank Bay
Access Door Open
APU Drip Pan Removed
Ramp Opened and Level

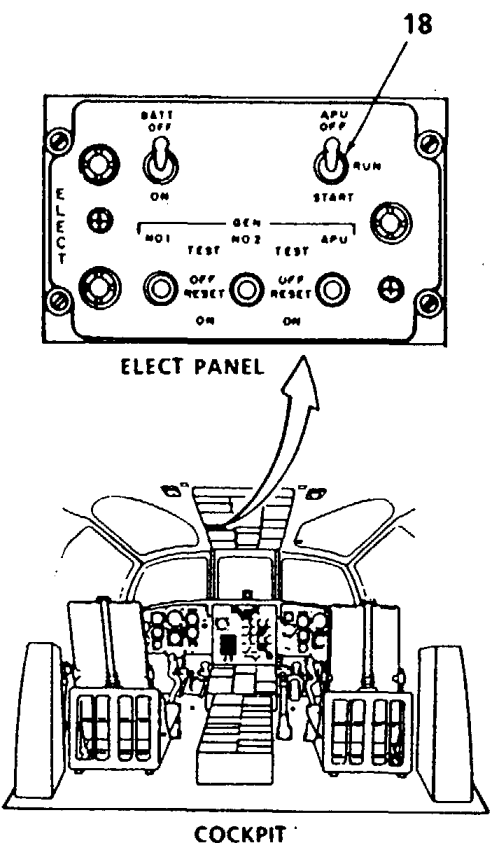
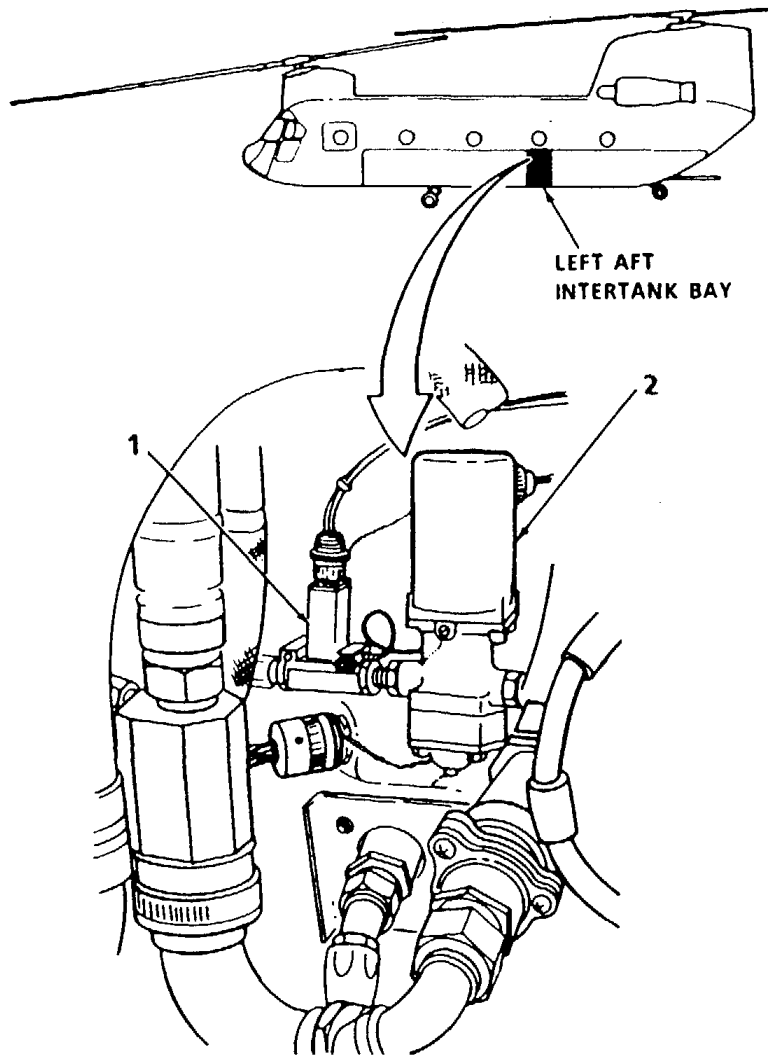
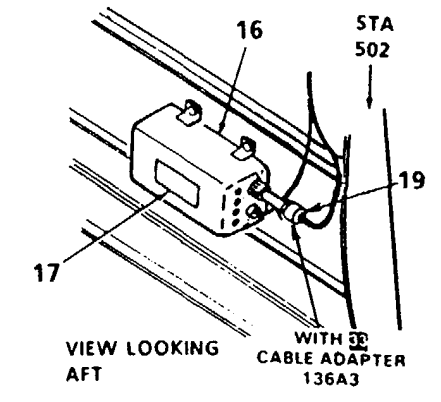
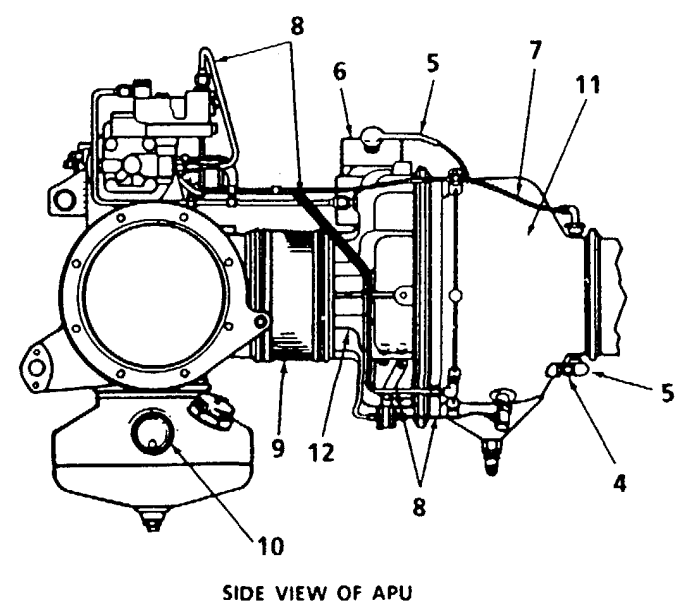
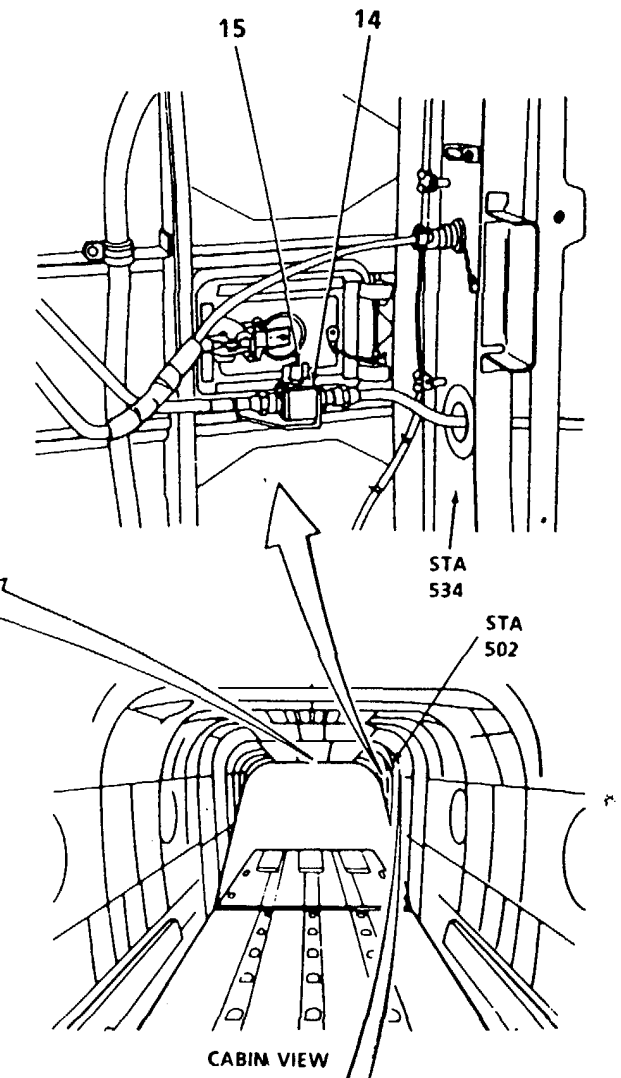
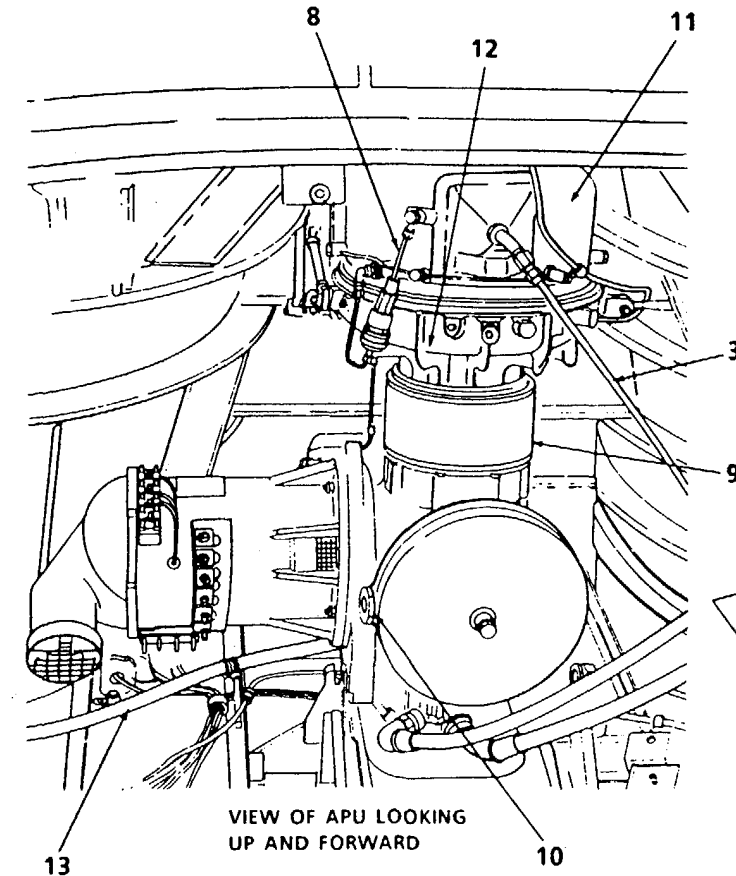

TASK	RESULT
1. Check APU fuel valve (1).	If fuel valve (1) is loose or damaged, tighten or replace it as required. If electrical connector or wiring to valve is damaged, replace connector or repair or replace wiring as required.
2. Check APU fuel boost pump (2).	If fuel boost pump (2) is loose or damaged, tighten or replace it as required. If electrical connector or wiring to pump is damaged, replace connector or repair or replace wiring as required.
3. Check APU combustor drain line (3).	If drain line (3) is kinked or damaged, replace it. If it is loose, tighten it.
4. Check APU spark plug (4), exciter cable (5), and ignition exciter (6).	If spark plug (4), exciter cable (5), or ignition exciter (6) is loose or damaged, tighten or replace it as required.
5. Check APU thermocouple cable (7).	If cable (7) is loose or damaged, tighten or replace it as required.
6. Check two APU fuel lines (8).	If any fuel line (8) is damaged, replace it.
7. Check APU air inlet screen (9).	If screen (9) is clogged, clean it.
8. Check APU oil level sight gage (10).	If oil level is low, service APU.
9. Check APU combustor case (11) and turbine case (12).	If either case (11 or 12) is cracked or damaged, replace APU.
10. Check APU fuel line (13).	If fuel line (13) is kinked or damaged, replace it.
11. Check APU fuel shutoff manual valve (14).	If valve (14) is loose or damaged, tighten or place it as required. If valve handle (15) is not in ne with fuel line, set it in that position.
12. Check electronic sequence unit (ESU) (16).	If ESU (16) is loose or damaged, tighten or replace as required. If electrical connector or wiring to U is damaged, replace connector or repair or place wiring as required. If bite information art (17) is damaged, replace it.
13. Check APU switch (18).	If switch (18) is loose or damaged, tighten or place it as required.
14. On helicopter with 33 , check cable adapter (19).	If cable adapter (19) is loose or damaged, tighten or replace it as required.

FOLLOW-ON MAINTENANCE:

TM 55-1520-240-23:

Left aft intertank bay access door closed

APU drip pan installed.

END OF TASK
Change 8 15-15

15-1.5 APU OPERATIONAL CHECK

INITIAL SETUP

Applicable Configurations:

All

Tools:

Stopwatch

Materials:

None **General Safety Instructions:**

Personnel Required:

Medium Helicopter Repairer (2)
Aircraft Electrician

References:

TM 55-1520-240-23

Equipment Condition:

TM 55-1520-240-23:
Battery Connected
Ext Electrical Power Off

Ext Hydraulic Power Off
APU Start Accumulator Charged to 2850 Psi
APU Visual Check Performed (Task 15-1.4)
Helicopter Positioned Nose into Wind
Rotor Blades Positioned So That One Aft Blade is Behind and 30 Degrees Off Centerline

WARNING

Keep hands away from flight controls. Application of hydraulic power will cause flight controls to move and rotor blades to flap. Injury to personnel can occur.

TASK	RESULT
1. Set BATT switch (1) to ON.	MASTER CAUTION lights (2) shall come on. If not, go to task 9-1.4.
2. Press pilot's MASTER CAUTION light (2).	MASTER CAUTION lights (2) shall go out. If not, go to task 9-18.3.
3. Check that APU CONT NORM and EMERG circuit breakers (3 and 4) are closed.	If circuit breaker (3 or 4) is open, close it. If either circuit breaker opens again, go to task 15-2.7.
NOTE	
Post fireguard at APU.	
4. Check that POWER XFR NO. 1 and POWER XFR NO. 2 switches (5 and 6) are at OFF.	If switches (5 or 6) are ON, set them to OFF.
5. Position helper to observe bite indicators on ESU (7).	
6. Set APU switch (8) to RUN. Hold at RUN for a minimum of <u>3 seconds</u> .	BITE indicator #1 on ESU (7) changes from black to white and then is reset to black. All other indicators remain black or are reset to black.
NOTE	
If Bite #1 is already white, this task resets it to black, along with the other BITE indicators.	

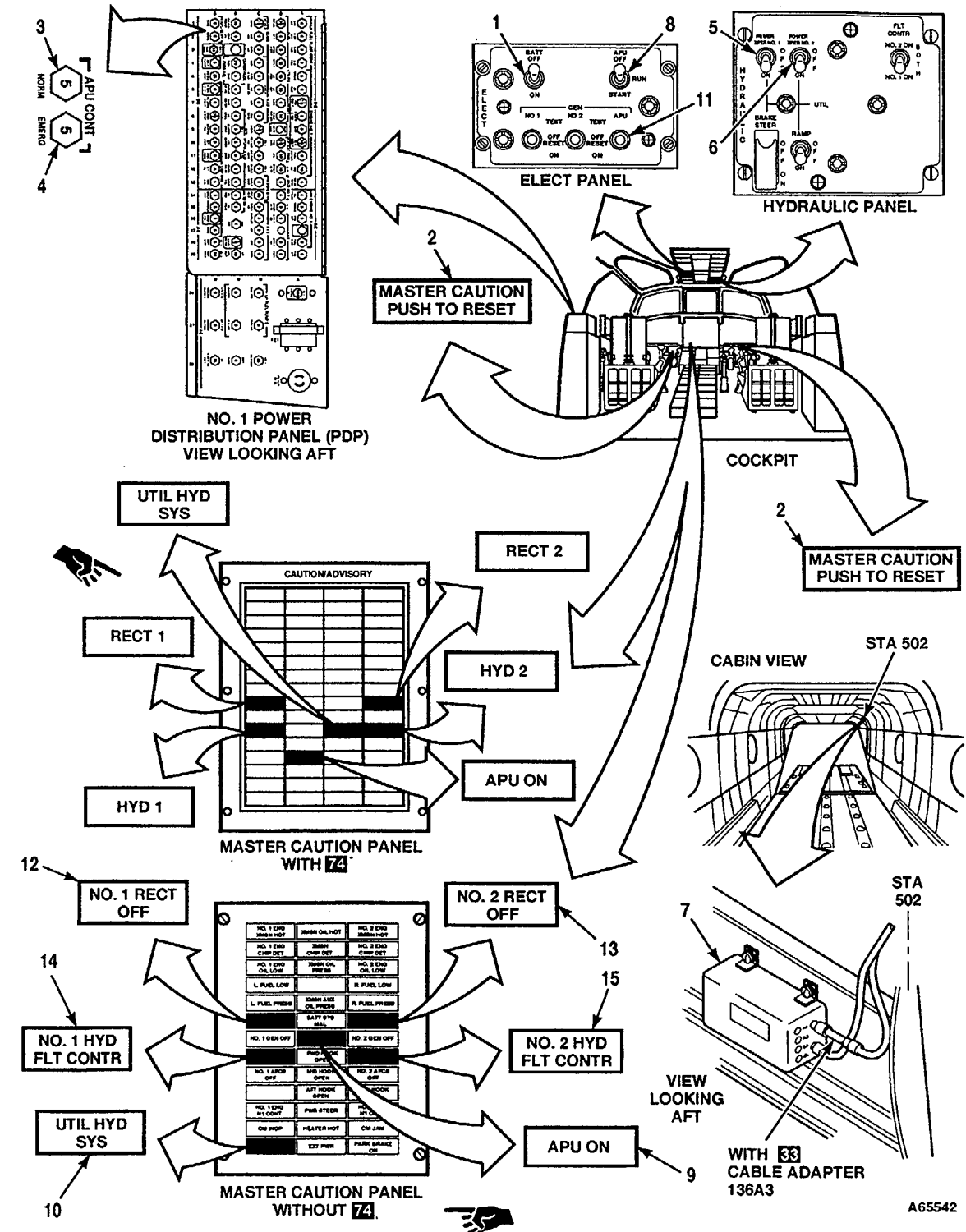

TASK	RESULT
<p>If BITE indicators do not remain black, go to task 15-2.8. If fuel boost pump cannot be heard operating, go to task 15-2.9.</p> <p>CAUTION</p> <p>If a roar is heard and a flame is seen at APU exhaust during APU start, shut down APU to prevent APU damage.</p> <p>CAUTION</p> <p>If there is no hydraulic pressure in <u>30 seconds</u> after APU switch is released to RUN, shut down APU.</p> <p>CAUTION</p> <p>If APU is to be restarted or another start attempt tried, wait at least <u>30 seconds</u> after APU has stopped before setting APU switch to START. This allows residual fuel to drain from APU, thereby preventing overspeed or overtemp condition.</p> <p>7. Set APU switch (8) to START for a minimum of 2 seconds then release it to RUN.</p> <p>NOTE</p> <p>Observe ESU bite indicators sequencing during start. Note last two sequences when automatic shutdown occurs. Do not move APU switch until bite indications are recorded unless hot start occurs.</p>	<p>APU shall begin to motor and accelerate to running speed within 30 seconds. ESU (7) BITE indicators shall sequence from all black to all white, then all black. APU ON capsule (9) shall come on. UTIL HYD SYS capsule (10) shall go out. If roar is heard and flame is seen at APU exhaust (hot start), shut down APU to prevent damage and go to task 15-6.17.</p> <p>If APU does not motor, go to task 15-2.10.</p> <p>If APU motors but does not start or starts and automatically shuts down, check ESU bite indicators and refer to table 15-2.2 for maintenance action. If APU runs and ESU bite is black but APU ON capsule is not on, go to task 15-2.13. If APU runs and UTIL HYD SYS capsule (10) does not go out, shut down APU and go to task 7-2.4.</p>

TASK	RESULT
<p>8. Set APU GEN switch (11) to ON.</p> <p>9. Set POWER XFR NO. 1 and POWER XFR NO. 2 switches (5 and 6) to ON.</p> <p>10. Open then close APU CONT NORM circuit breaker (3).</p> <p>11. Open then close APU CONT EMERG circuit breaker (4).</p> <p>12. Set POWER XFR NO. 1 and POWER XFR NO. 2 switches (5 and 6) to OFF.</p> <p>13. Set APU GEN switch (11) to OFF.</p> <p>14. Set APU switch (8) to OFF.</p> <p>CAUTION</p> <p>Cycling of the APU switch during APU coastdown may cause the APU to restart with a possible overtemperature.</p>	<p>NO. 1 RECT OFF and NO. 2 RECT OFF (Without 74) and RECT 2 (With 74) capsules (12 and 13) shall go out. APU ON capsule (9) shall stay on. If capsules do not go out, go to task 9-1.4. If APU capsule goes out, check ESU bite indicators and refer to table 15-2.2 and/or task 15-2.14.</p> <p>NO. 1 HYD FLT CONTR and NO. 2 HYD FLT CONTR (Without 74) or RECT 1 and RECT 2 (With 74) capsules (14 and 15) shall go out. If not, go to task 7-2.15. APU ON capsule (9) shall stay on. If it goes out, check ESU bite indicators and refer to table 15-2.2.</p> <p>APU ON capsule (9) shall stay on. If it goes out, go to task 15-2.11.</p> <p>APU ON capsule (9) shall stay on. If it goes out, go to task 15-2.11.</p> <p>NO. 1 HYD FLT CONTR and NO. 2 FLT CONTR (Without 74) or RECT 1 and RECT 2 (With 74) capsules (14 and 15) shall come on.</p> <p>NO. 1 RECT OFF and NO. 2 RECT OFF (Without 74) or RECT 1 and RECT 2 (With 74) capsules (12 and 13) shall come on. APU shall remain running. If APU shuts down, go to task 15-2.15.</p> <p>APU shall shut down. APU ON capsule (9) shall go out. If APU does not shut down, go to task 15-2.12.</p>
<p>FOLLOW-ON MAINTENANCE: TM 55-1520-240-23: Battery disconnected. Electrical power off.</p>	

15-2 APU ELECTRICAL SYSTEM

**PARAGRAPH 15-2
TABLE OF CONTENTS**

APU ELECTRICAL SYSTEM TROUBLESHOOTING

PARAGRAPH	DESCRIPTION	FUNCTION	PAGE
15-2	APU ELECTRICAL SYSTEM		
15-2.1	APU STARTING SEQUENCE FAILURES	TABLE	15-25
15-2.2	APU SYSTEMS BITE INDICATION FAILURE TABLE	TABLE	15-26
15-2.3	APU ELECTRICAL SYSTEM COMPONENTS	DRAWING	15-28
15-2.4	APU ELECTRICAL CONTROL SYSTEM BLOCK DIAGRAM	DRAWING	15-29
15-2.5	APU ELECTRICAL SCHEMATIC	DRAWING	15-30
15-2.6	APU WIRING DIAGRAM	DRAWING	15-31
15-2.7	APU CONT NORM OR APU CONT EMERG CIRCUIT BREAKER DOES NOT STAY CLOSED	TASK	15-32
15-2.8	ESU BITE INDICATORS DO NOT CYCLE AFTER APU SWITCH SET TO RUN	TASK	15-34
15-2.9	APU FUEL BOOST PUMP CANNOT BE HEARD OPERATING BEFORE APU SWITCH SET TO START	TASK	15-36
15-2.10	APU DOES NOT MOTOR WHEN APU SWITCH SET TO START	TASK	15-38
15-2.11	APU ON CAPSULE GOES OUT (APU SHUTS DOWN) WHEN APU CONT CIRCUIT BREAKER OPENED	TASK	15-41
15-2.12	APU DOES NOT STOP. ESU INDICATORS ARE BLACK ●●●●	TASK	15-42
15-2.13	APU ON CAPSULE OUT WHEN APU OPERATING NORMALLY	TASK	15-44
15-2.14	APU SHUTS DOWN WHEN GEN APU SWITCH PLACED TO ON. ESU BITE INDICATES ●●●●	TASK	15-46
15-2.15	APU SHUTS DOWN WHEN APU GEN SWITCH IS SET TO OFF	TASK	15-47

**PARAGRAPH 15-2
LIST OF TABLES**

APU ELECTRICAL SYSTEM TROUBLESHOOTING

TABLE NO.	DESCRIPTION	PAGE NO.
15-2.1	APU STARTING SEQUENCE FAILURES	15-25
15-2.2	BITE INDICATION TABLE FOR APU SYSTEMS FAILURES	15-26

AUXILIARY POWER UNIT SYSTEM ELECTRICAL COMPONENT LOCATION AND CONFIGURATION LIST

REF DESIG	PART NUMBER	TYPE	MATE WITH/LOCATION	STATION LOCATION			REF DESIG	PART NUMBER	TYPE	MATE WITH/LOCATION	STATION LOCATION		
				FS	WL	BL					FS	WL	BL
GD128		151	LH AFT CABIN	360	32	50L	232P1	MS3476W22-55S	27	MASTER CAUTION PANEL-CENTER			
GD129		151	AFT AT APU AREA	594	60	20R				INST PNL (WITH 74)			
GD130		151	LH AFT TAIL	510	50	45L	232P3	MS3476W14-19S	21	MASTER CAUTION PANEL-CENTER			
GD153		151	LH AFT CABIN	380	-15	50L				INST PNL (WITH 74)			
P302	MS3456W10SL-4S	46	MAGNETIC PICKUP-APU	605	65	0L	300J1	M83723-74A2041N	40	NO. 1 PDP-COCKPIT			
P303	MS3456L10SL-3S	70	IGNITION EXCITER-APU	605	66	8R	300P1	M83723-75A2041N	40	NO. 1 PDP-COCKPIT			
TB3	MS27212-1-12	160	NO. 1 PDP-COCKPIT	90	-15	30L	300J19	M83723-73A2041N	40	OVERHEAD PANEL-COCKPIT			
TB301	MS27212-1-5	160	APU	605	65	6R	300P19	M83723-76A2041N	40	OVERHEAD PANEL-COCKPIT			
136K1	MS24149-D1	106	APU FAULT RELAY	360	40	50L	300J21	M83723-74A2461N	43	OVERHEAD PANEL-COCKPIT			
136P1	M83723-96A1624N	35	J1 OF ESU	520	40	50L	300P21	M83723-75A2461N	43	OVERHEAD PANEL-COCKPIT			
136P2	M83723-95A1415N	34	J2 OF ESU	520	40	50L	300J50	M83723-73A2461N	43	ELECTRONICS COMPARTMENT-OVHD	120	40	20L
136J3	MS3474W12-3S	16	AIRCRAFT SKIN-TANK SIDE-CABLE TO APU FUEL PUMP-LH POD	380	-5	50L	300P50	M83723-76A2461N	43	ELECTRONICS COMPARTMENT-OVHD	120	40	20L
136P4	MS3456W10SL-4S	46	APU FUEL VALVE-LH POD	375	-20	54L	300J54	M83723-74A2461N	43	AFT CROWN	460	50	20L
136P5	M83723-95A1005N	30	APU HYD START VALVE	575	50	30R	300P54	M83723-75A2461N	43	AFT CROWN	460	50	20L
136P6	M83723-95A1624N	71	J301 OF APU	594	65	8L	300J61	M83723-73A24619	43	CONSOLE-UNDERFLOOR (WITHOUT 74)	85	-20	10L
174J5	MS3474W14-19S	21	AIRCRAFT SKIN-INSIDE	385	-5	50L	300J61	M83723-73W24619	28	CONSOLE-UNDERFLOOR (WITH 74)	85	-20	10L
174P5	MS3476W14-19P	21	AIRCRAFT SKIN-TANK SIDE	385	-5	50L	300P61	M83723-76A24619	43	CONSOLE-UNDERFLOOR (WITHOUT 74)	85	-20	10L
232P1	MS3476W20-41S	24	MASTER CAUTION PANEL-CENTER INST PNL (WITHOUT 74)				300P61	M83723-76W24619	28	CONSOLE-UNDERFLOOR (WITH 74)	85	-20	10L

AUXILIARY POWER UNIT SYSTEM ELECTRICAL COMPONENT LOCATION AND CONFIGURATION LIST (Continued)

RECEPTACLE

PLUG

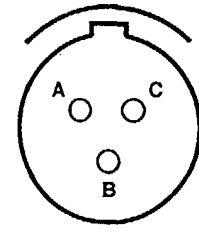

16

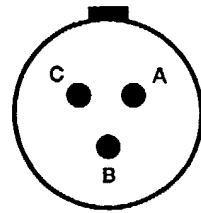

16

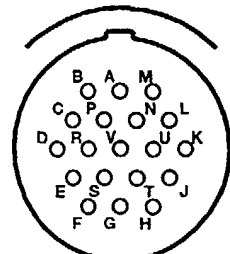

21

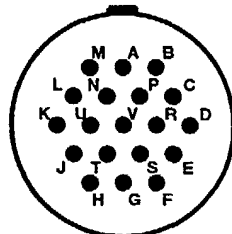

21

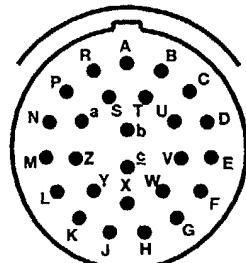

24

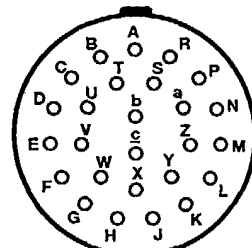

24

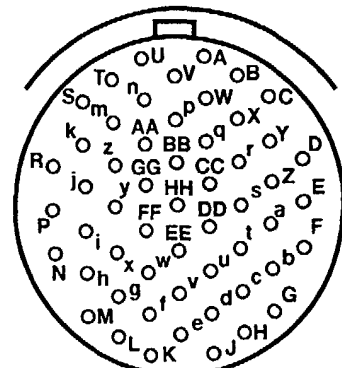

27

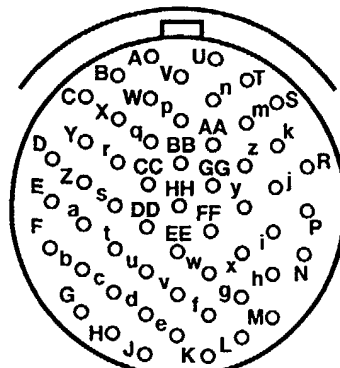

27

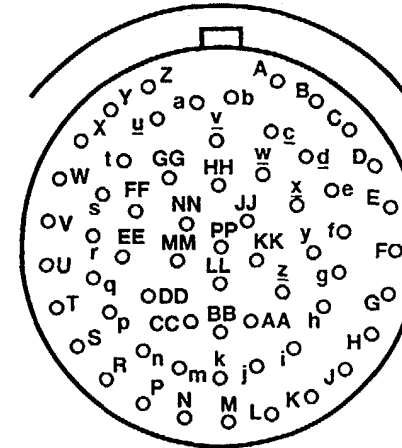

28

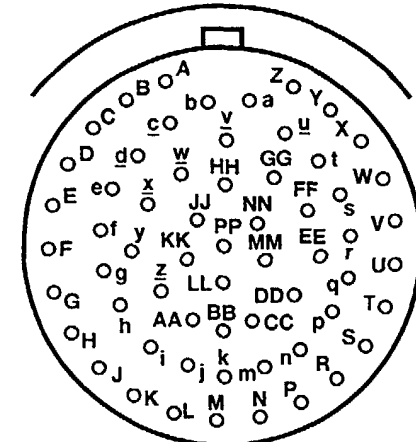

28

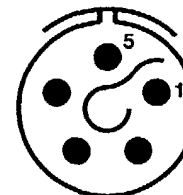

30

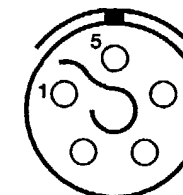

30

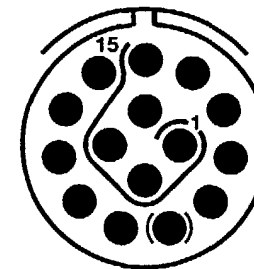

34

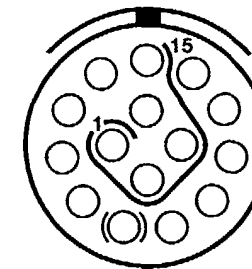

34

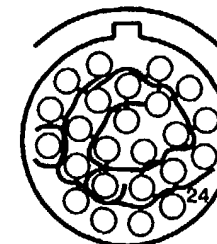

35

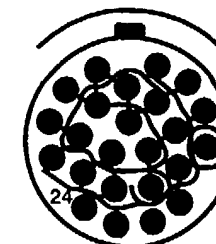

35



A72531

AUXILIARY POWER UNIT SYSTEM ELECTRICAL COMPONENT LOCATION AND CONFIGURATION LIST (Continued)

RECEPTACLE

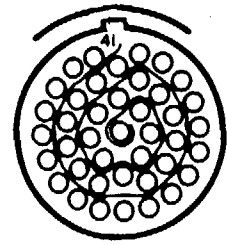

40

PLUG

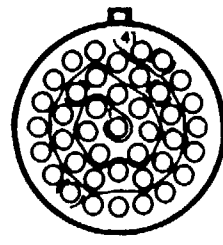

40

RECEPTACLE

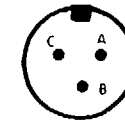

70

PLUG

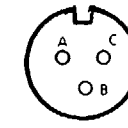

70

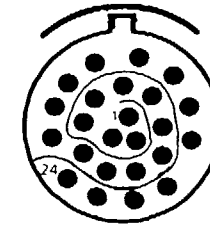

71

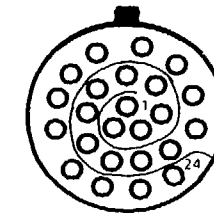

71

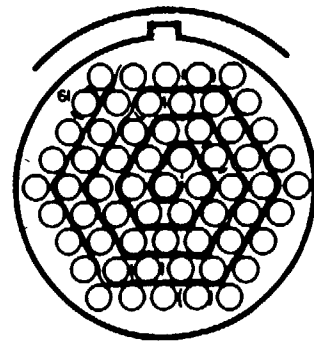

43

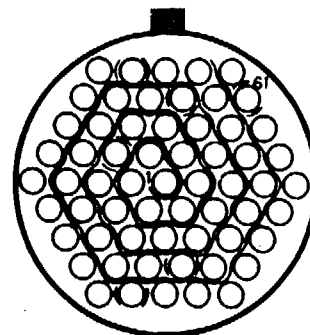

43

RELAY

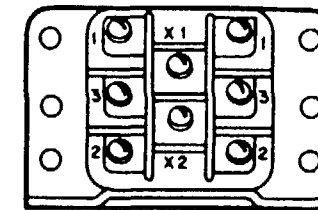

106

RELAY

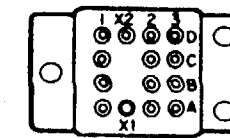

103

GND STUD



151



46



46

TERMINAL BOARD

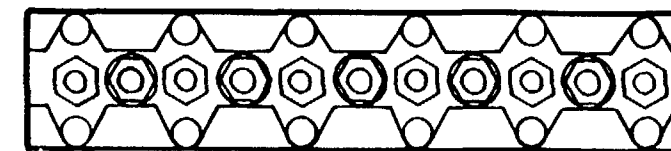

160

15-2 APU ELECTRICAL SYSTEM

15-2.1 APU STARTING SEQUENCE FAILURES

TABLE NO. 15-2.1 APU STARTING SEQUENCE FAILURES					
APU STARTING SEQUENCE	No.	SYMPTOM	BITE INDICATION	DECODED BITE INFORMATION	TASK
PRE START					
	1	APU DOES NOT MOTOR ESU Bite indicates	○○○○	<u>NO TEMP DATA</u>	15-2.10
MOTORING					
	2	APU MOTORS BUT DOES NOT START ESU Bite indicates	○●○○	<u>NO SPEED DATA</u>	15-6.11
	3	APU MOTORS BUT DOES NOT START ESU Bite indicates	○●●● or ○○●● then ●○○●	<u>FAILURE TO START</u>	15-6.12
	4	APU MOTORS BUT DOES NOT START ESU Bite indicates	○○○● then ●○○●	<u>FAILURE TO START</u>	15-6.13
STARTING					
	5	APU STARTS BUT SHUTS DOWN ESU Bite indicates	●●○●	<u>OVERSPEED</u>	15-6.14
	6	APU STARTS BUT SHUTS DOWN ESU Bite indicates	○●○●	<u>UNDERSPEED</u>	15-6.15
	7	APU STARTS BUT SHUTS DOWN ESU Bite indicates	●●○○	<u>OPEN THERMOCOUPLE</u>	15-6.18
HOT START					
	8	APU STARTS BUT SHUTS DOWN ESU Bite indicates	○○●●	<u>OVERTEMPERATURE</u>	15-6.17
STARTS AND RUNS					
	9	APU STARTS AND RUNS but ESU Bite indicates	●○●○	<u>SHORTED THERMO. PROBE (warning)</u>	15-6.19

TABLE NO. 15-2.2 BITE INDICATION TABLE FOR APU SYSTEMS FAILURES				
NO.	BITE INDICATION	SYMPTOM	DECODED BITE DESCRIPTION	Maintenance Action
				Task No.
APU DOES NOT MOTOR:				
1	○●●●	ESU Bite indicates ○●●●	PROCESSOR BOARD FAILURE	15-2.10
2	●○●●	ESU Bite indicates ●○●●	SENSOR / DATA BOARD FAILURE	15-2.10
3	●○○○	ESU Bite indicates ●○○○	PROCESSOR SEQUENCE FAIL	15-2.10
4	○○○○	ESU Bite indicates ○○○○	NO TEMP DATA	15-2.10
APU MOTORS BUT DOES NOT START:				
5	○○●● then ●○○●	ESU Bite indicates ●○○●	FAILURE TO START	15-3.6
6	○○○● then ●○○●	ESU Bite indicates ●○○●	FAILURE TO START	15-3.7
7	○●●● or ○○●● then ●○○●	ESU Bite indicates ●○○●	FAILURE TO START	15-4.11
8	○●○○	ESU Bite indicates ○●○○	NO SPEED DATA	15-6.11
9	○●●● or ○○●● then ●○○●	ESU Bite indicates ●○○●	FAILURE TO START	15-6.12
10	○○○● then ●○○●	ESU Bite indicates then ●○○●	FAILURE TO START	15-6.13

TABLE NO. 15-2.2 BITE INDICATION TABLE FOR APU SYSTEMS FAILURES (Continued)				
NO.	BITE INDICATION	SYMPTOM	DECODED BITE DESCRIPTION	Maintenance Action
				Task No.
APU STARTS BUT SHUTS DOWN				
11	○○○○ then ●●○○	ESU Bite indicates ●●○○●	OVERSPEED	15-6.14
12	○○○● then ○●○○	ESU Bite indicates ○●○○●	UNDERSPEED	15-6.15
13	○○○● then ○○●●	ESU Bite indicates ○○●●●	OVERTEMPERATURE (HOT START)	15-6.16
14	○○●● then ●●○○	ESU Bite indicates ●●○○○	OPEN THERMOCOUPLE	15-6.18
APU STARTS AND RUNS BUT SHUTS DOWN				
15	○○○○ then ○○●●	ESU Bite indicates ○○●●●	OVERTEMPERATURE (HOT START)	15-6.17
APU STARTS AND RUNS				
16	●○○○	ESU Bite indicates ●○○○○	SHORTED THERMO. PROBE (WARNING)	15-6.19
APU SHUTS DOWN WHEN GEN APU SWITCH PLACED TO ON				
17	●●●●	ESU Bite indicates ●●●●●	READY FOR SERVICE	15-2.14
APU SHUTS DOWN WHEN APU GEN SWITCH IS SET TO OFF				
18	●●●●	ESU Bite indicates ●●●●●	READY FOR SERVICE	15-2.15
APU DOES NOT STOP				
19	●●●●	ESU Bite indicates ●●●●●	READY FOR SERVICE	15-2.12

END OF TASK

Change 8 15-27

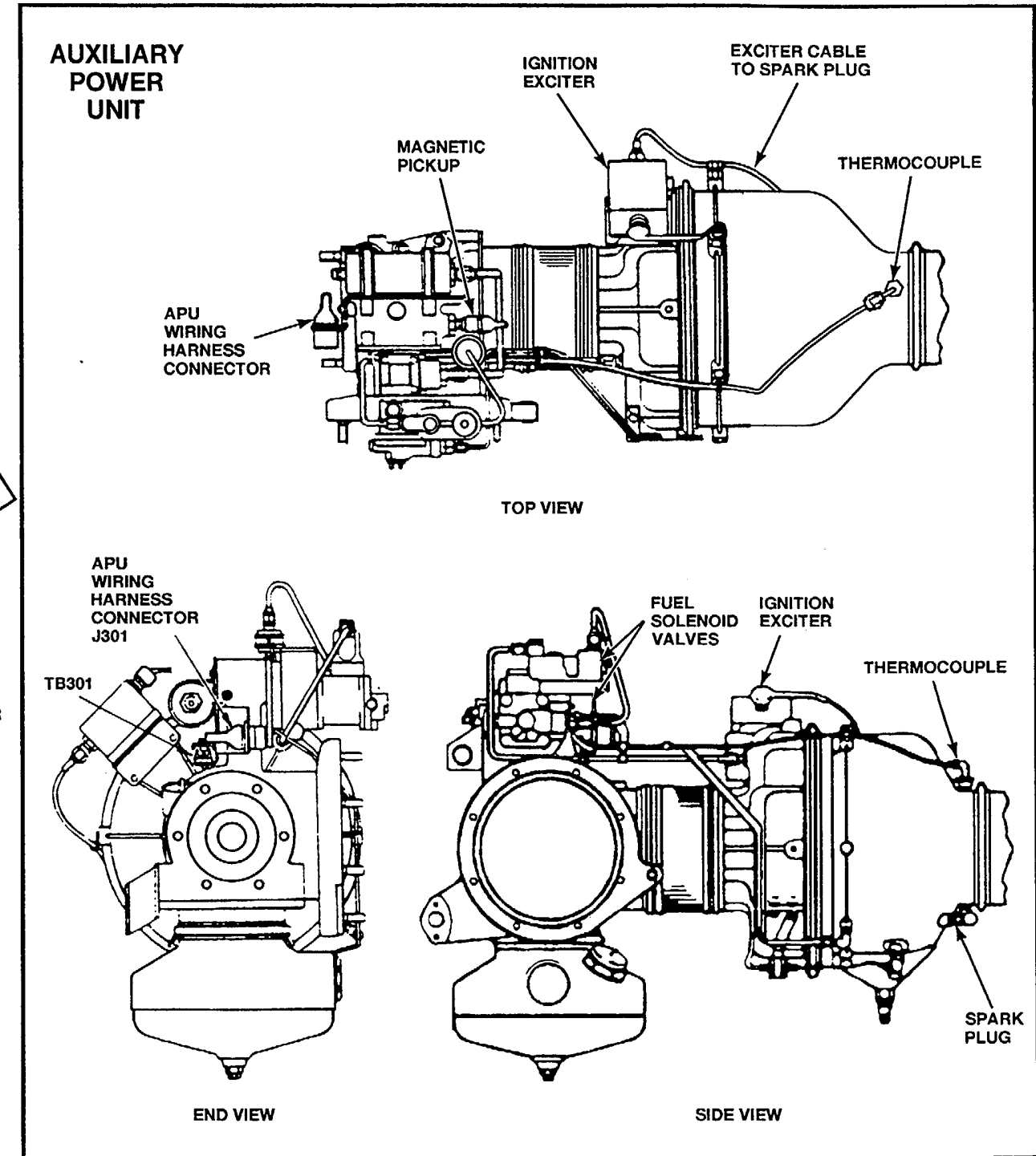
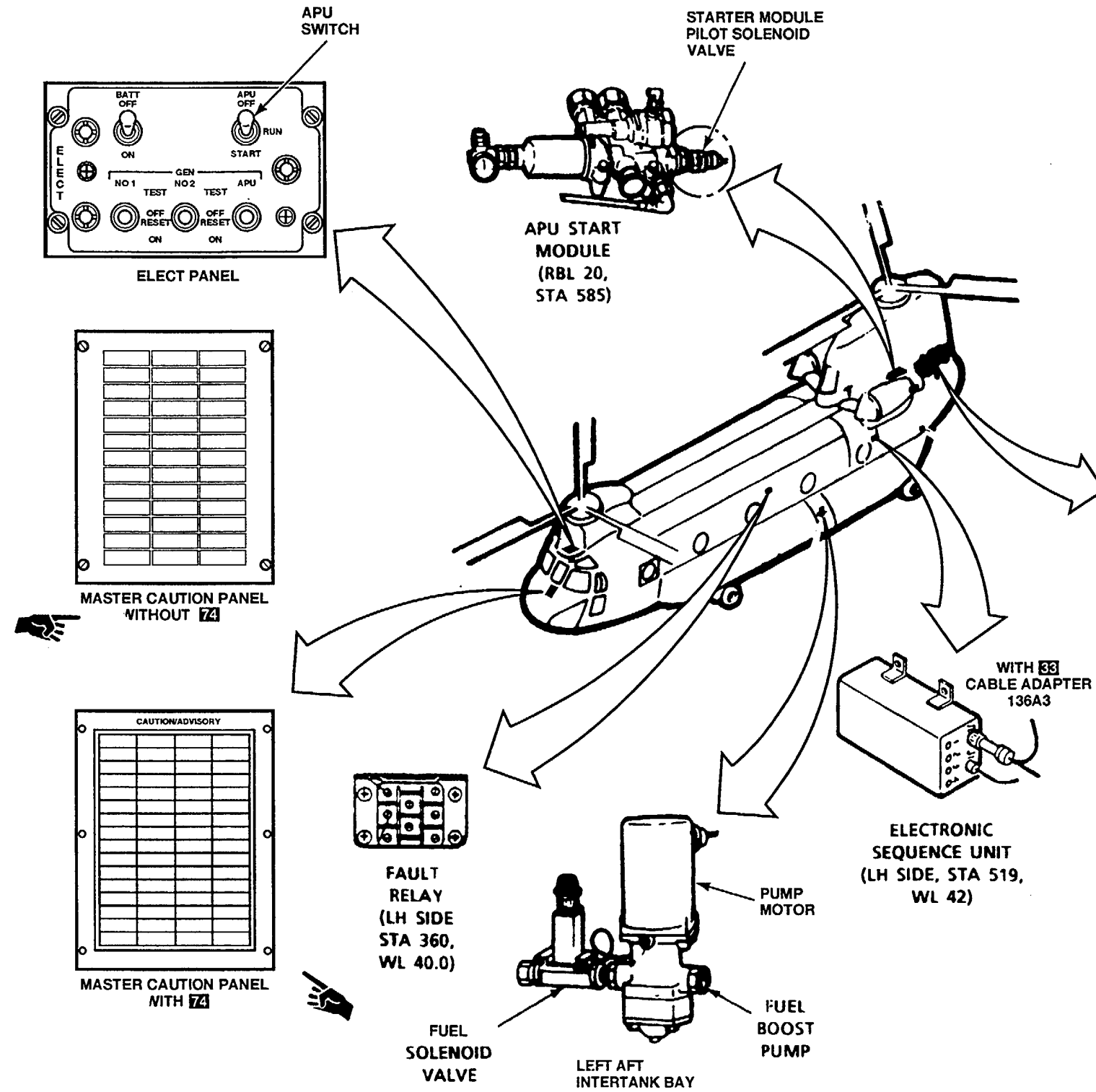

A72504

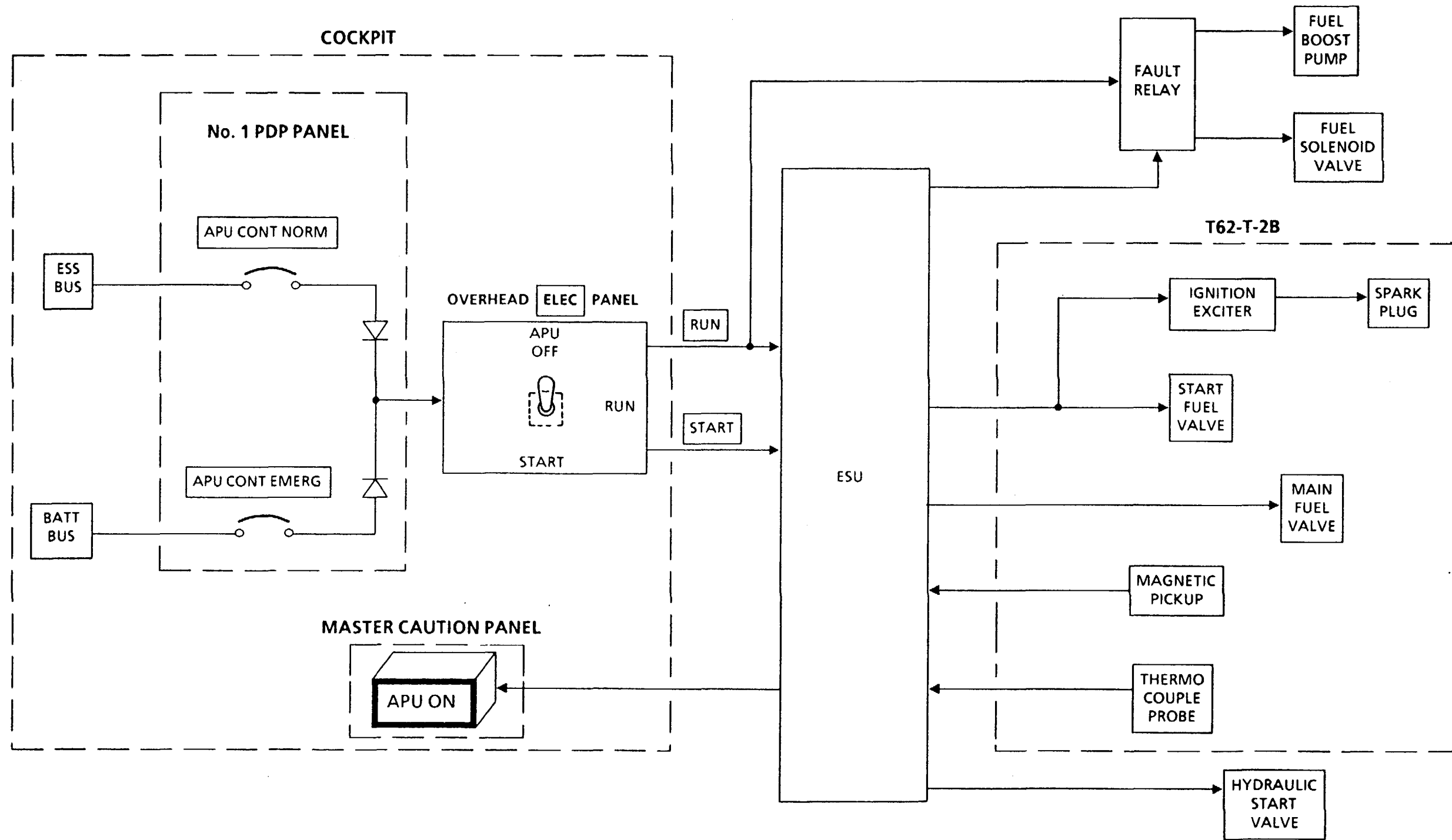

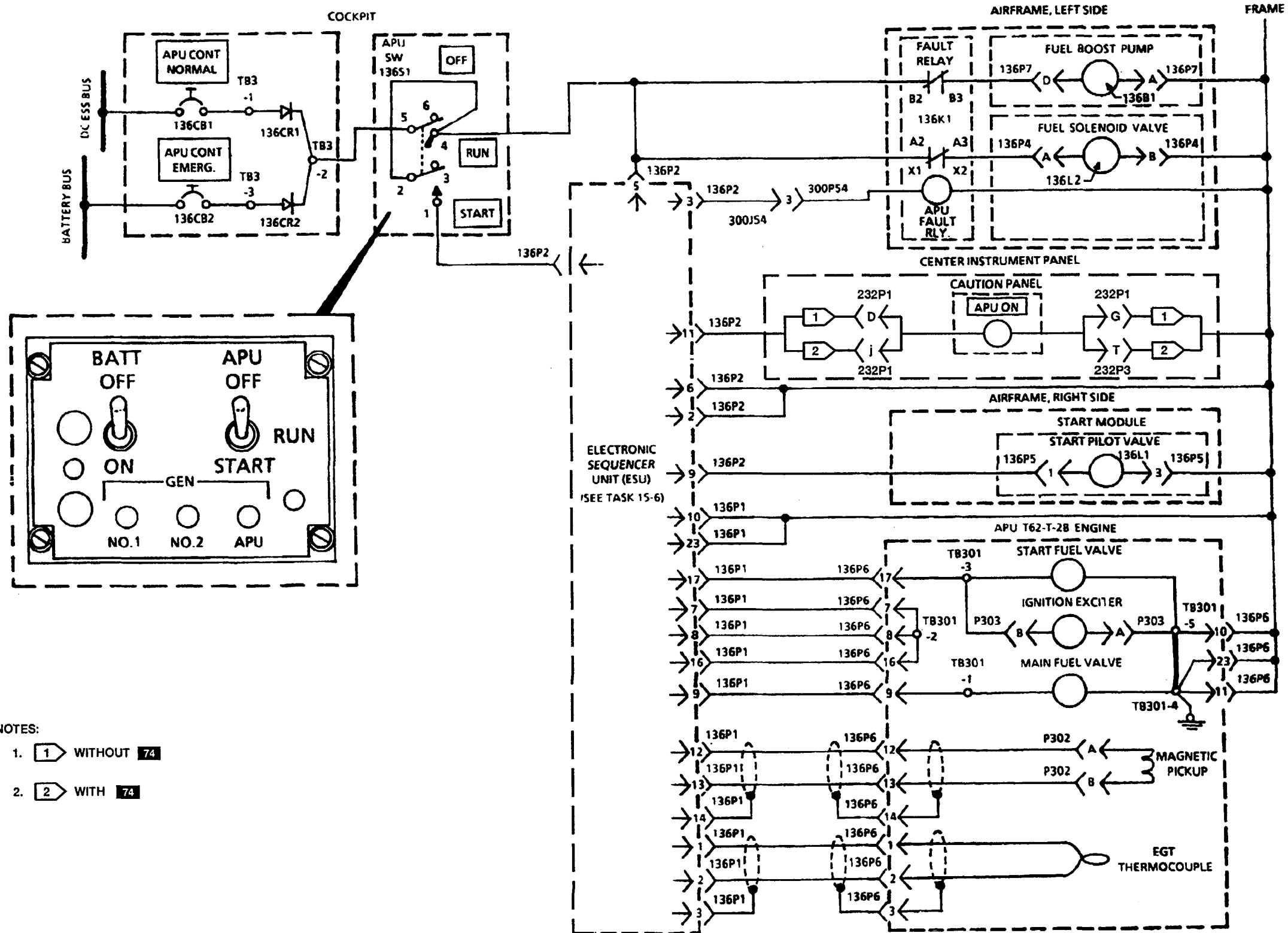

NOTES:

1. WITHOUT
2. WITH

A72530

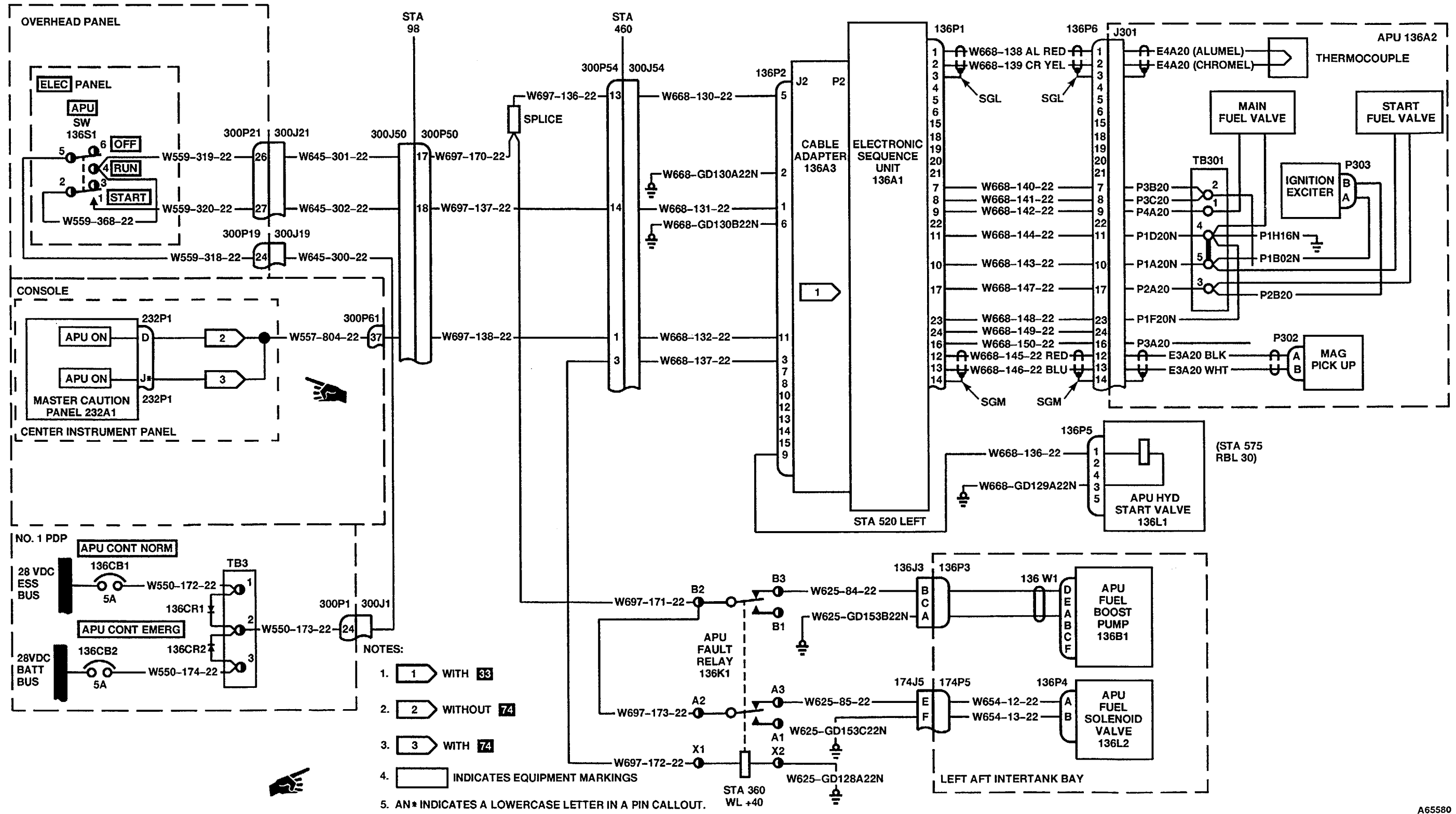

A65580

15-2.7 APU CONT NORM OR APU CONT EMERG CIRCUIT BREAKER DOES NOT STAY CLOSED

FAULT ISOLATION PROCEDURE

INITIAL SETUP

Applicable Configurations:

All

Tools:

Electrical Repairer's Tool Kit.
NSN 5180-00-323-4915

Materials:

None

Personnel Required:

68F20 Aircraft Electrician

References:

TM 55-1520-240-23

Equipment Condition:

TM 55-1520-240-23:

Battery Disconnected

Electrical Power Off

Hydraulic Power Off

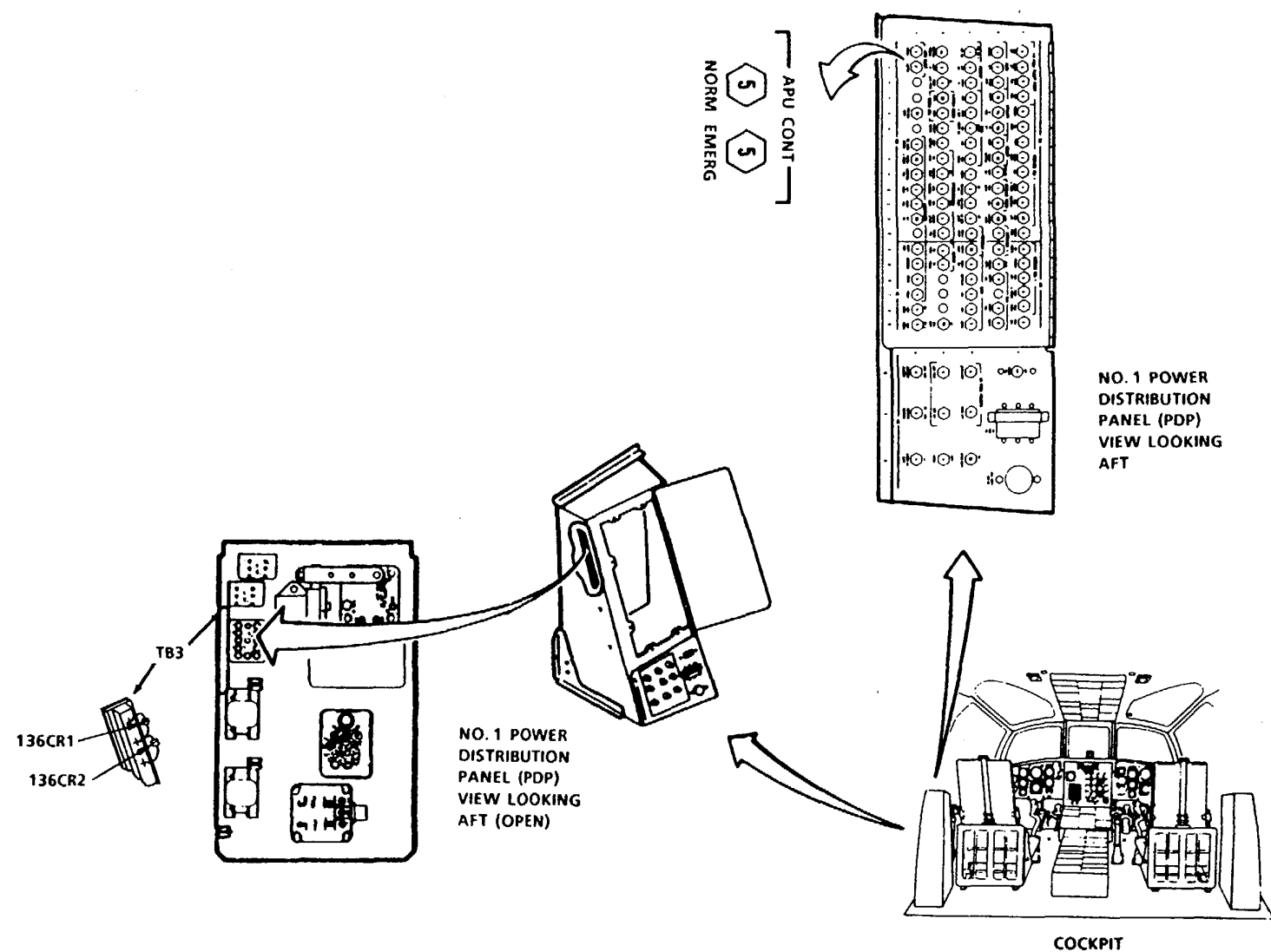

GO TO NEXT PAGE

15-2.7 APU CONT NORM OR APU CONT EMERG CIRCUIT
BREAKER DOES NOT STAY CLOSED (CONTINUED)

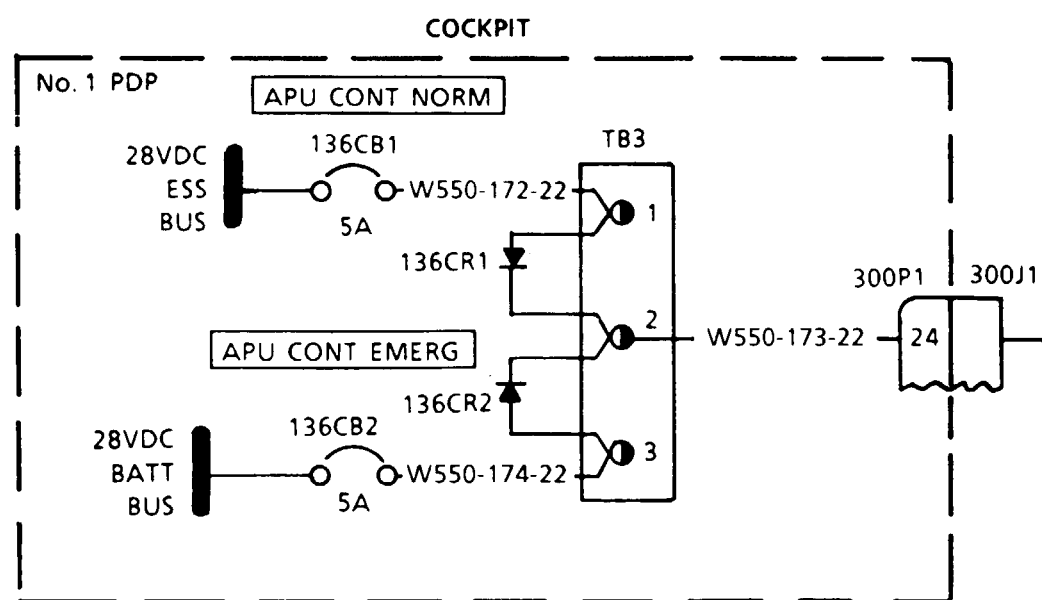

APU CONT "NORM" CIRCUIT BREAKER DOES NOT STAY CLOSED

REMOVE ELEC PWR. OPEN
NO 1 PDP. LOCATE
GROUND FAULT ON WIRE
W550-172-22 BETWEEN APU
CONT NORM CB 136CB1
AND TB3 TERM 1. REPAIR
OR REPLACE WIRE AS
REQUIRED

APU CONT "EMERG" CIRCUIT BREAKER DOES NOT STAY CLOSED

REMOVE ELEC PWR. OPEN
NO 1 PDP. LOCATE
GROUND FAULT ON WIRE
W550-174-22 BETWEEN APU
CONT EMERG CB 136CB2
AND TB3 TERM 3. REPAIR
OR REPLACE WIRE AS
REQUIRED

END OF TASK

15-2.8 ESU BITE INDICATORS DO NOT CYCLE AFTER APU SWITCH SET TO RUN

FAULT ISOLATION PROCEDURE

INITIAL SETUP

Applicable Configurations:
All

Tools:
Electrical Repairer's Tool Kit.
NSN 5180-00-323-4915
Multimeter

Materials:
None

Personnel Required:
Aircraft Electrician (2)

References:
TM 55-1520-240-23
TM 55-1500-343-23

Equipment Condition:
TM 55-1520-240-23:
Battery Connected
Electrical Power On
Hydraulic Power Off

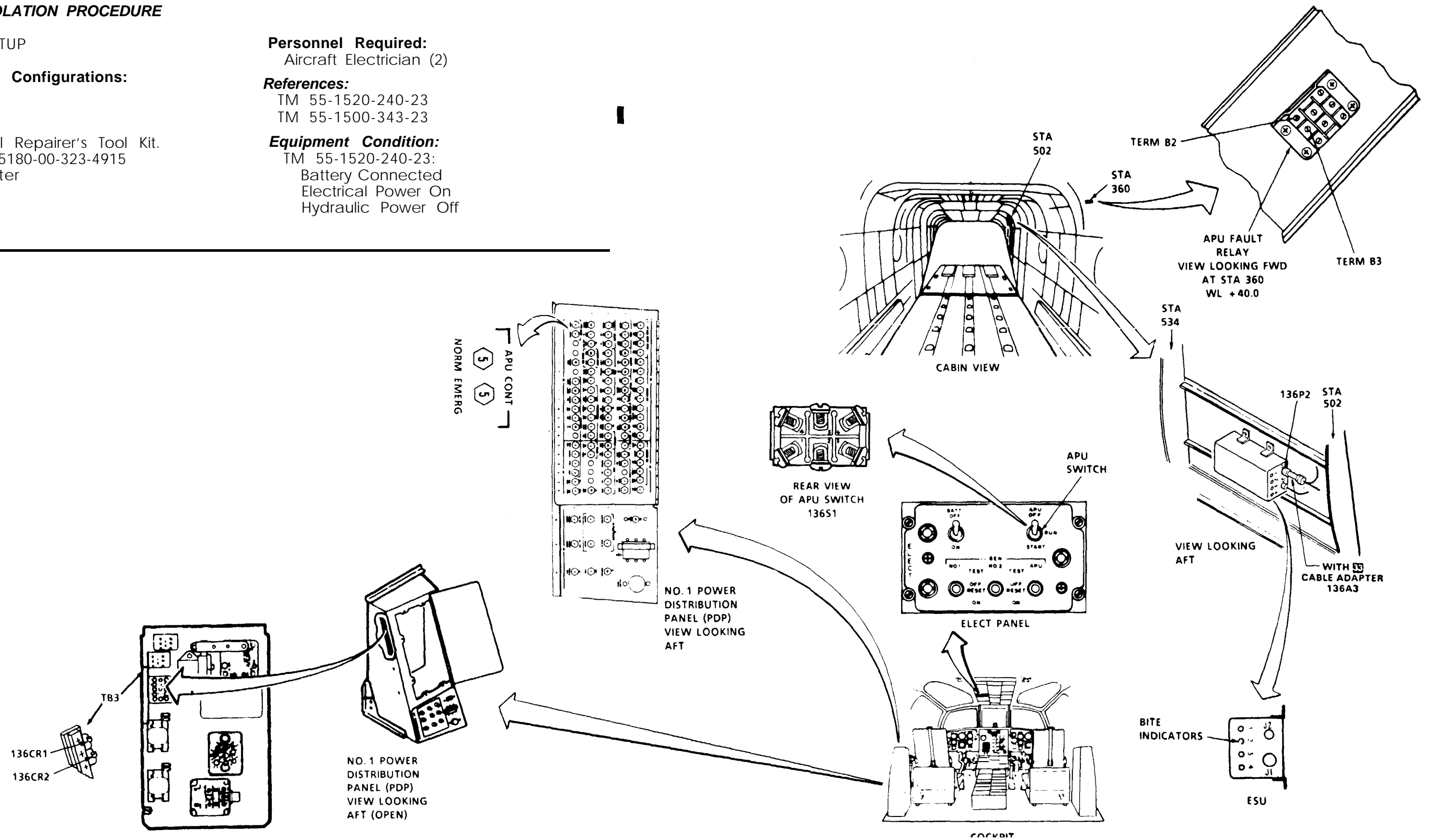

GO TO NEXT PAGE

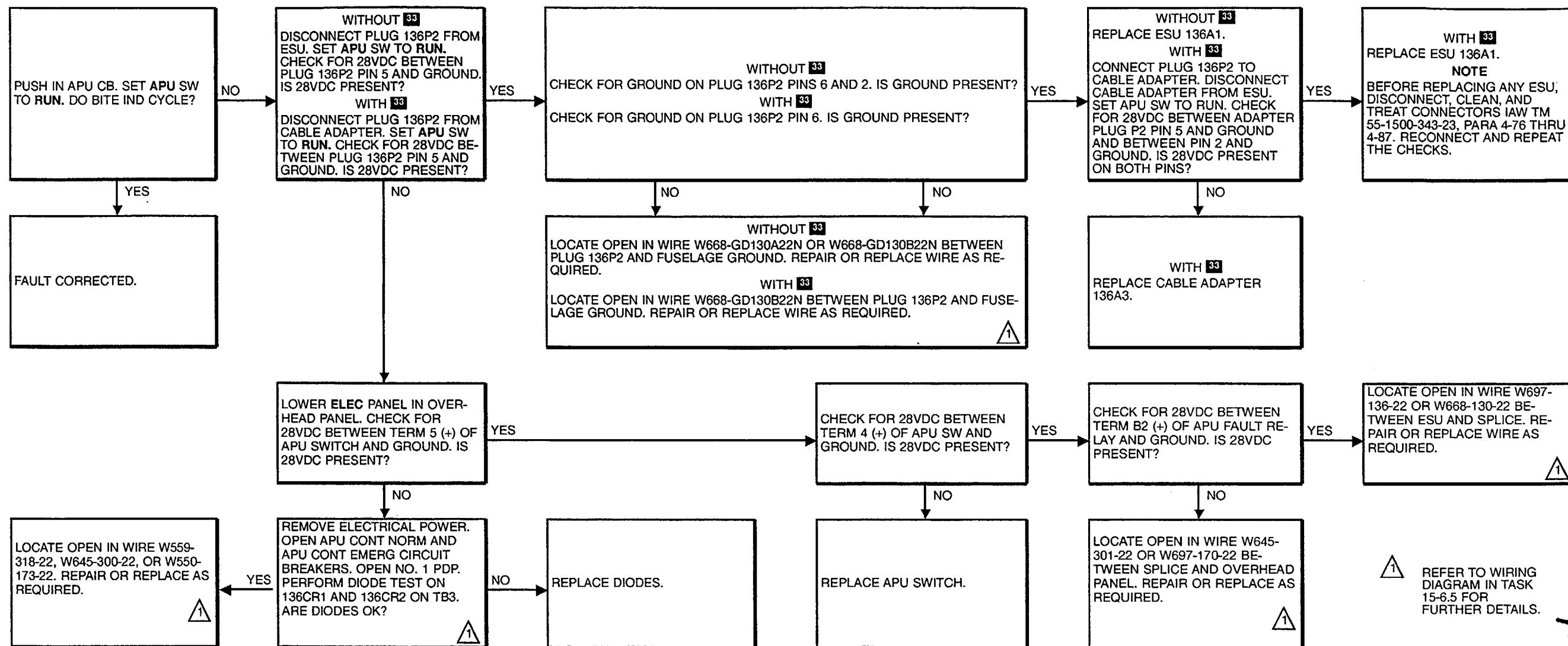

END OF TASK

Change 23 15-35

15-2.9 APU FUEL BOOST PUMP CANNOT BE HEARD OPERATING BEFORE APU SWITCH SET TO START

FAULT ISOLATION PROCEDURE

INITIAL SETUP

Applicable Configurations:
All

Tools:
Electrical Repairer's Tool Kit.
NSN 5180-00-323-4915
Multimeter

Materials:
None

Personnel Required:
Aircraft Electrician (2)

References:
TM 55-1520-240-23
TM 55-1500-343-23

Equipment Condition:
TM 55-1520-240-23:
Battery Connected
Electrical Power On
Hydraulic Power Off

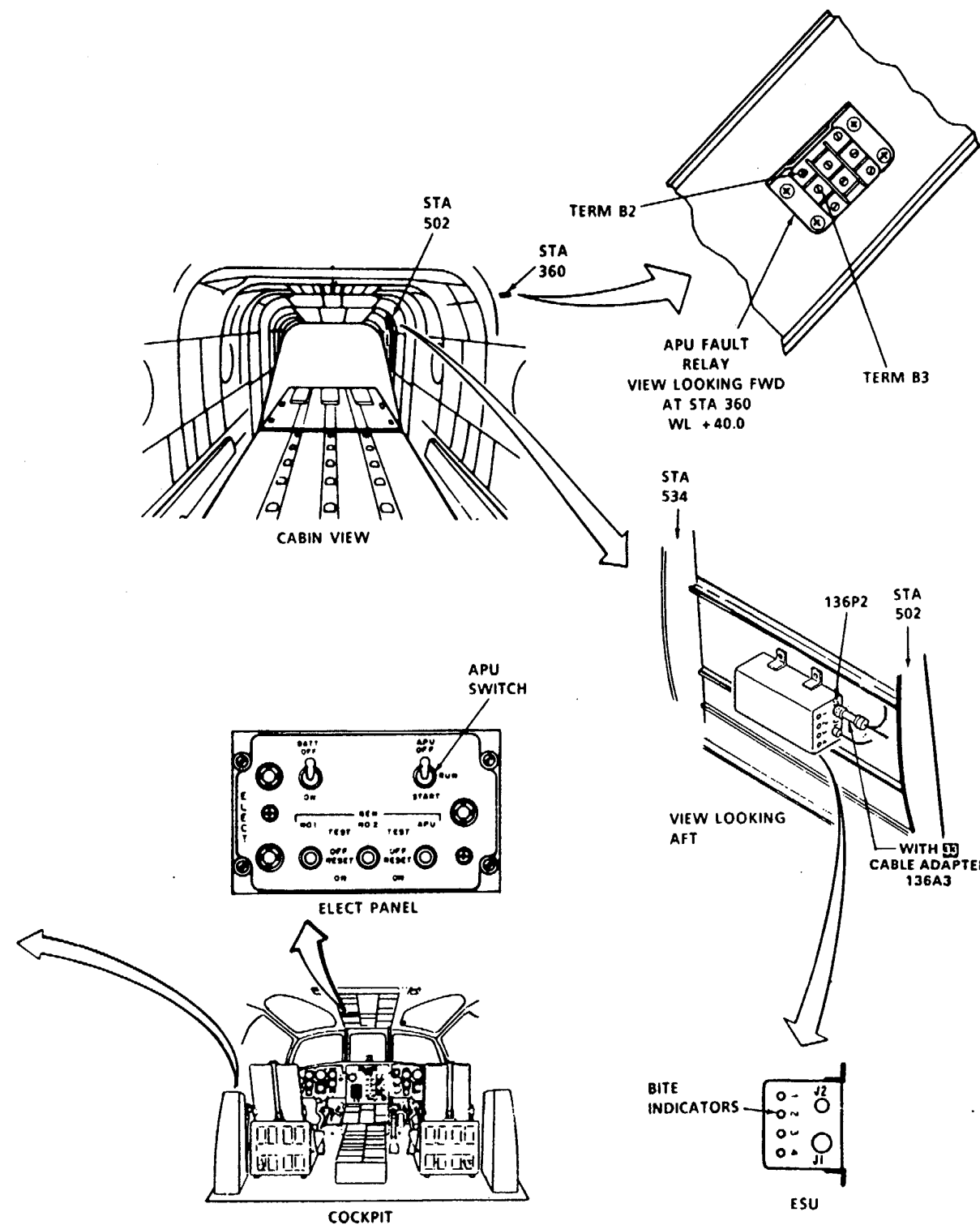
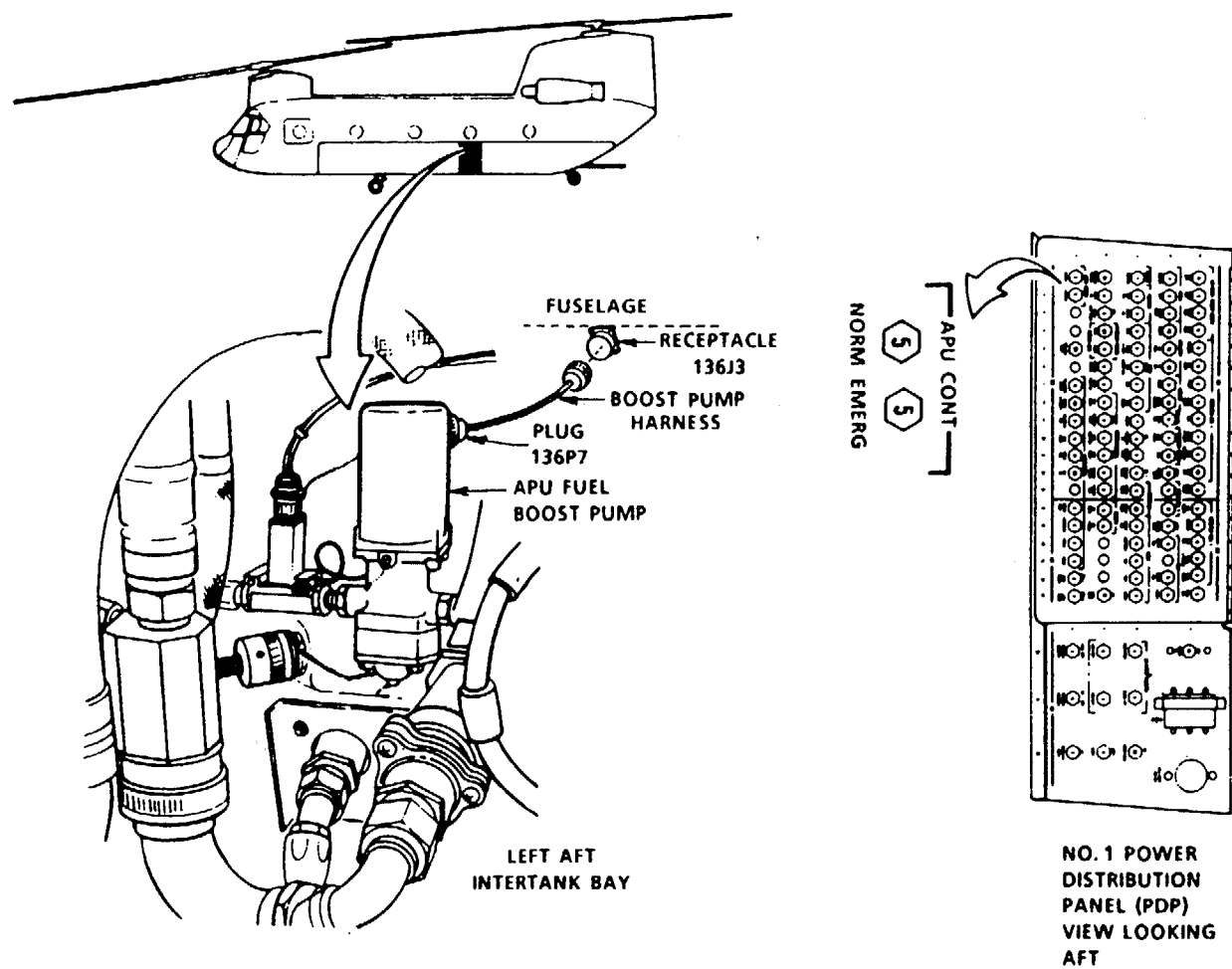

GO TO NEXT PAGE

15-2.9 APU FUEL BOOST PUMP CANNOT BE HEARD OPERATING BEFORE APU SWITCH SET TO START (Continued)

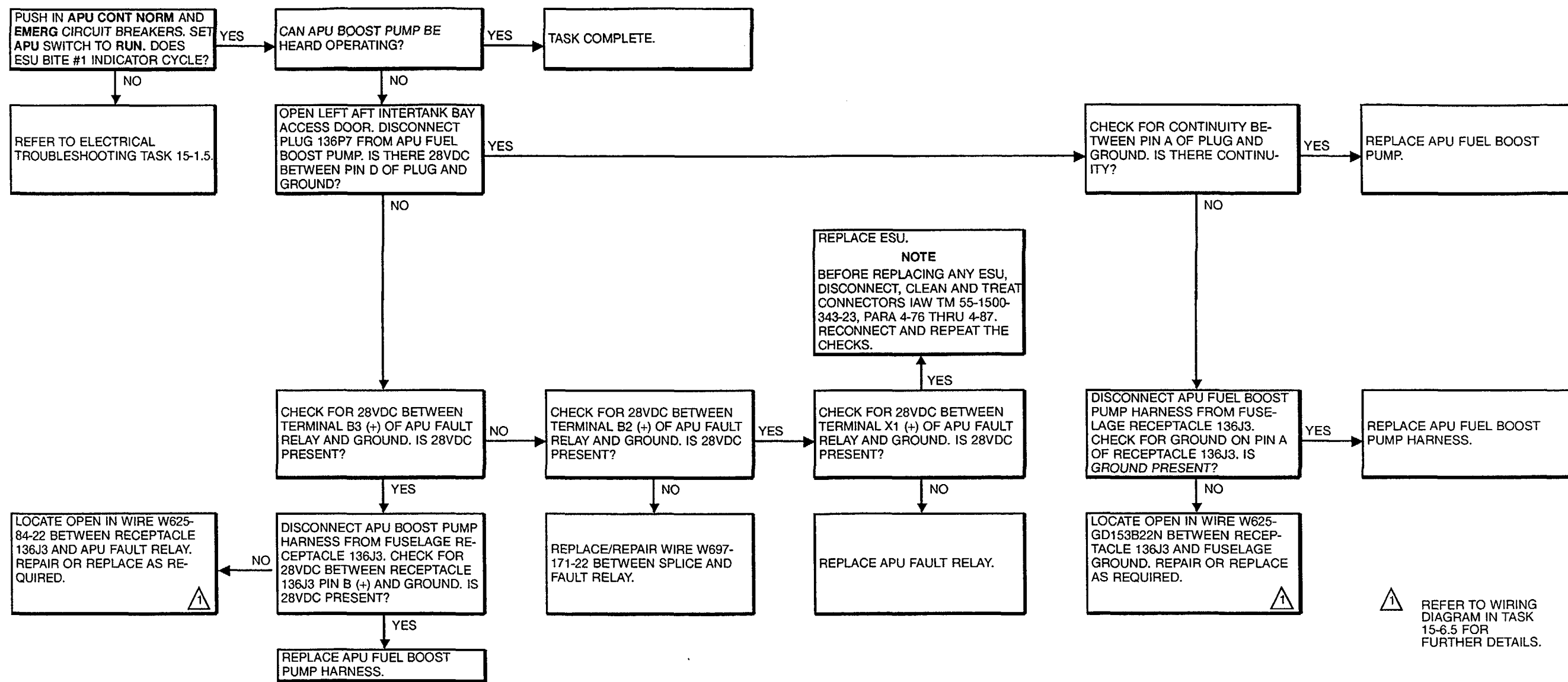

⚠ REFER TO WIRING DIAGRAM IN TASK 15-6.5 FOR FURTHER DETAILS.



END OF TASK

Change 23 15-37

15-2.10 APU DOES NOT MOTOR WHEN APU SWITCH IS SET TO START

FAULT ISOLATION PROCEDURE

INITIAL SETUP

Applicable Configurations:
All

Tools

Electrical Repairer's Tool Kit.
NSN 5180-00-323-4915
Multimeter

Materials:

None

Personnel Required:
Aircraft Electrician (2)

References:
TM 55-1520-240-23
TM 55-1500-343-23

Equipment Condition:
TM 55-1520-240-23:
Battery Connected
Electrical Power On
Hydraulic Power Off

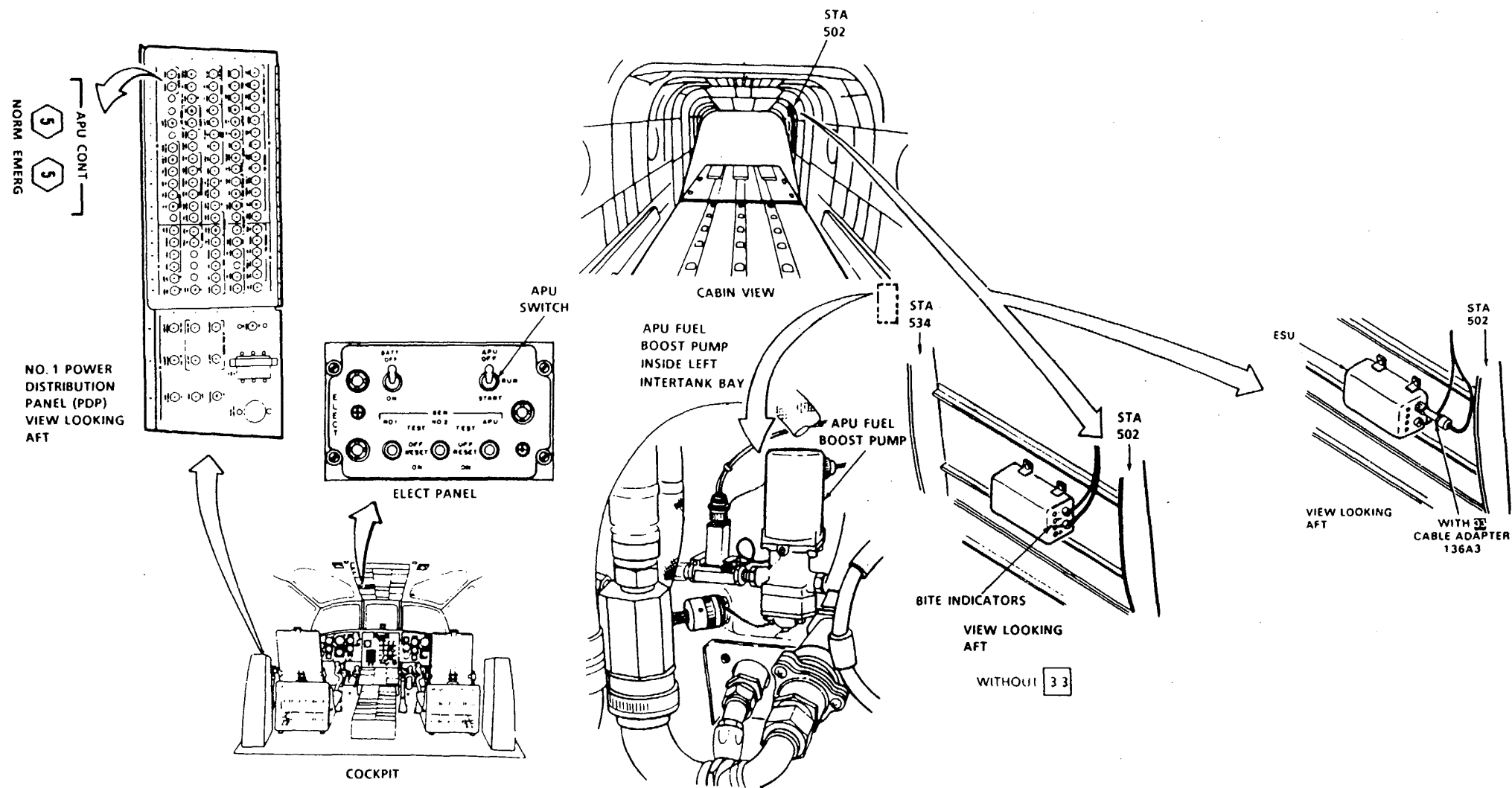

15-2.10 APU DOES NOT MOTOR WHEN APU SWITCH IS SET TO START
(CONTINUED)

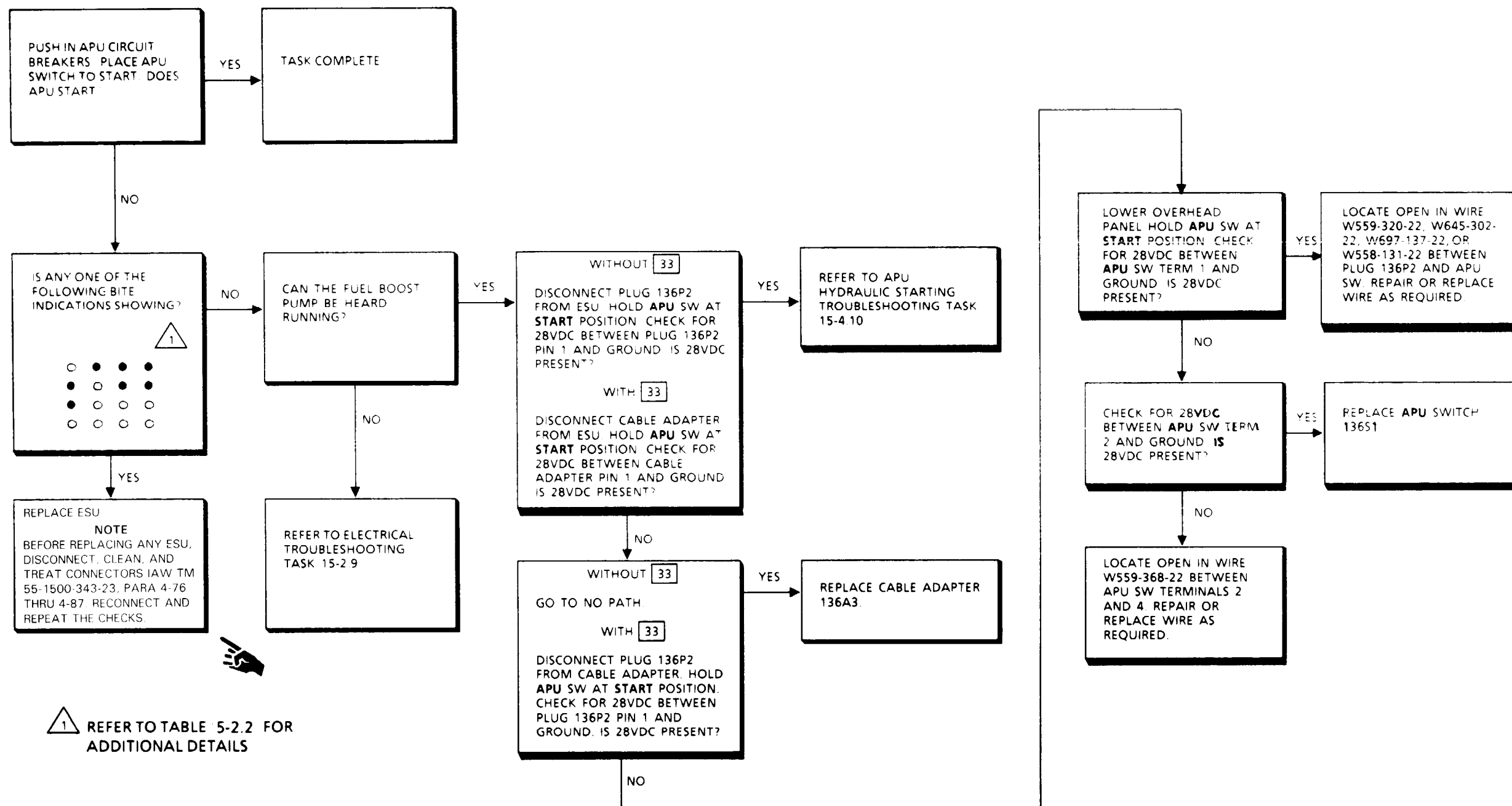

1 REFER TO TABLE 5-2.2 FOR ADDITIONAL DETAILS

END OF TASK

15-2.11 APU ON CAPSULE GOES OUT (APU SHUTS DOWN)
WHEN APU CONT CIRCUIT BREAKER OPENED

15-2.11

FAULT ISOLATION PROCEDURE

INITIAL SETUP

Personne/ Required:
Aircraft Electrician

Applicable Configurations:
All

References:
TM 55-1520-240-23

Tools:
Electrical Repairer's Tool Kit.
NSN 5180-00-323-4915
Multi meter

Equipment Condition:
TM 55-1520-240-23:
Battery Disconnected
Electrical Power Off
Hydraulic Power Off

Materials:
None

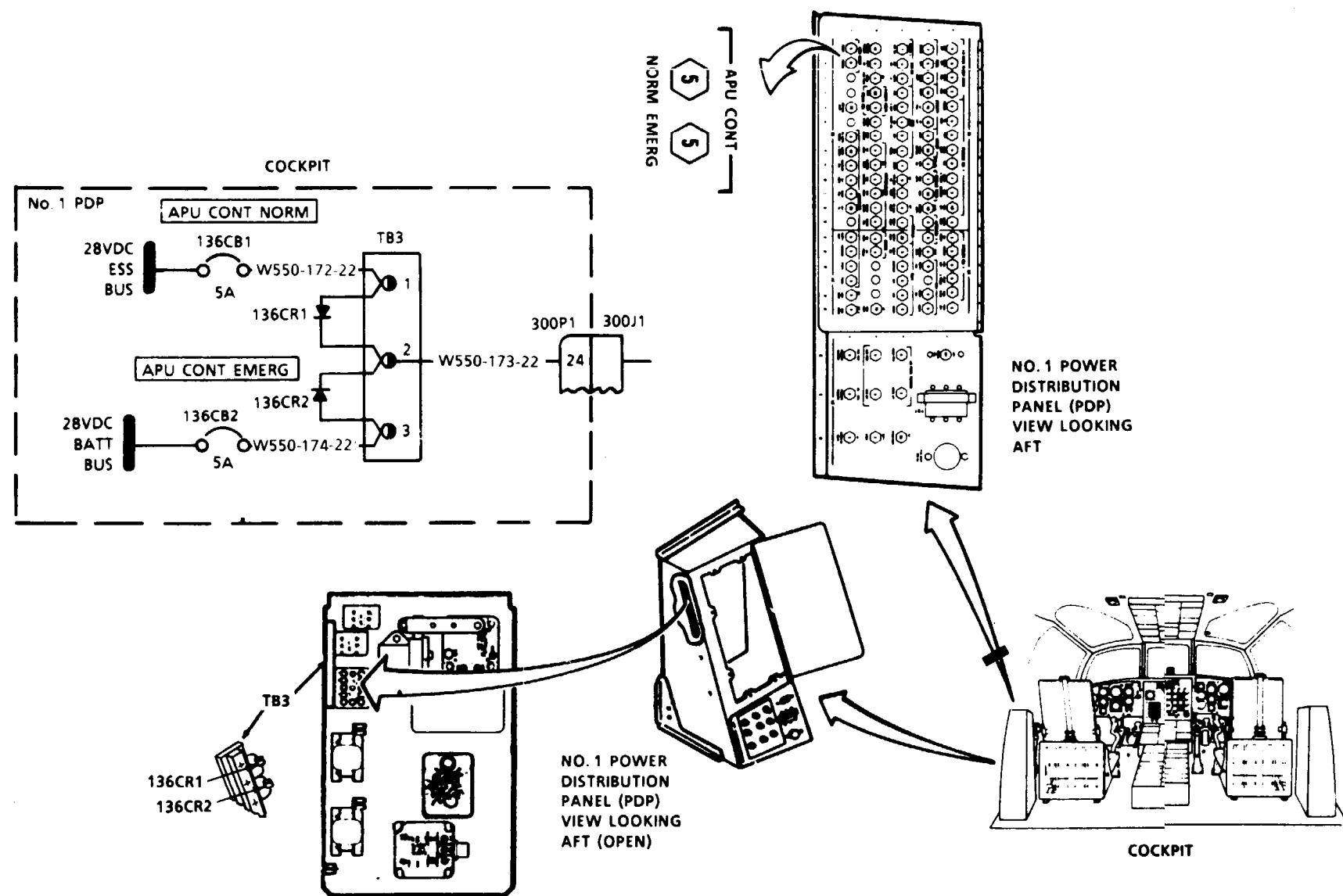

APU ON CAPSULE GOES OUT (APU SHUTS DOWN)
WHEN APU CONT "EMERG" CIRCUIT BREAKER OPENED

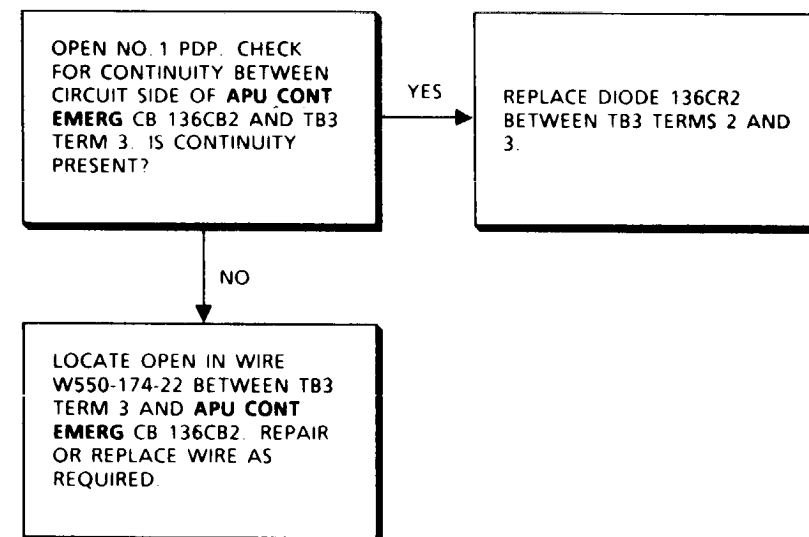

APU ON CAPSULE GOES OUT (APU SHUTS DOWN)
WHEN APU CONT "NORM" CIRCUIT BREAKER OPENED

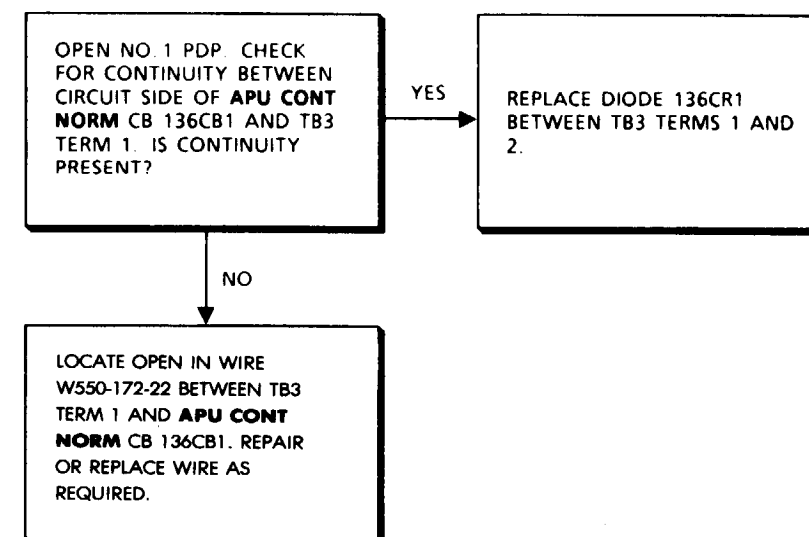

END OF TASK

15-2.12 APU DOES NOT STOP.
ESU BITE INDICATES ● ● ● ●

FAULT ISOLATION PROCEDURE

INITIAL SETUP

Applicable Configurations:
All

Tools:
Aircraft Mechanic's Tool Kit.
NSN 5180-00-323-4692
Electrical Repairer's Tool Kit.
NSN 5180-00-323-4915
Multimeter

Materials:
Cloth (E120)
Tape (E385)

Personnel Required:
Aircraft Electrician
Medium Helicopter Repairer

References:
TM 55-1520-240-23
TM 55-2835-205-23

Equipment Condition:
TM 55-1520-240-23:
Battery Connected
Electrical Power On
Hydraulic Power Off

General Safety Instructions:

WARNING

All regulations and instructions for handling fuels shall be strictly observed.

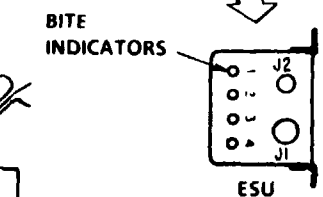
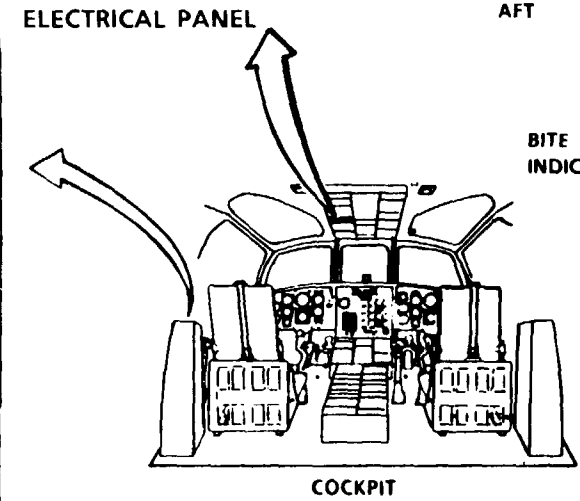
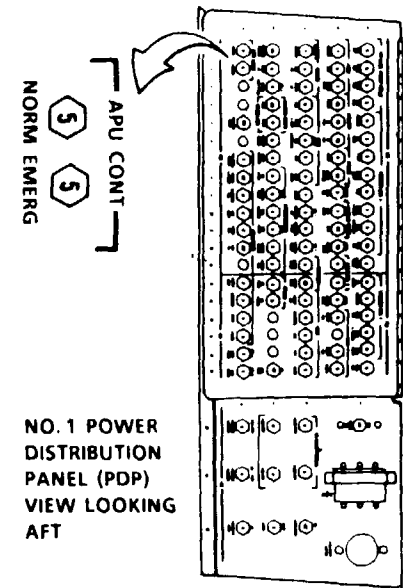
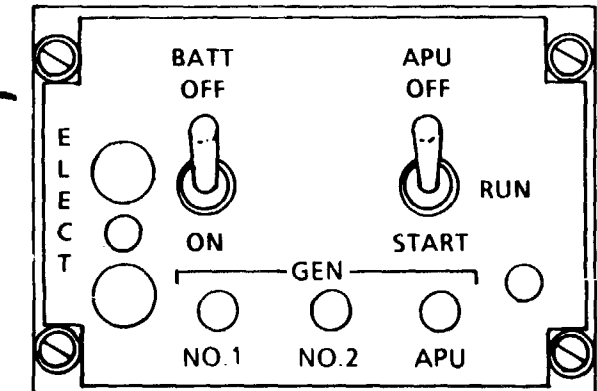
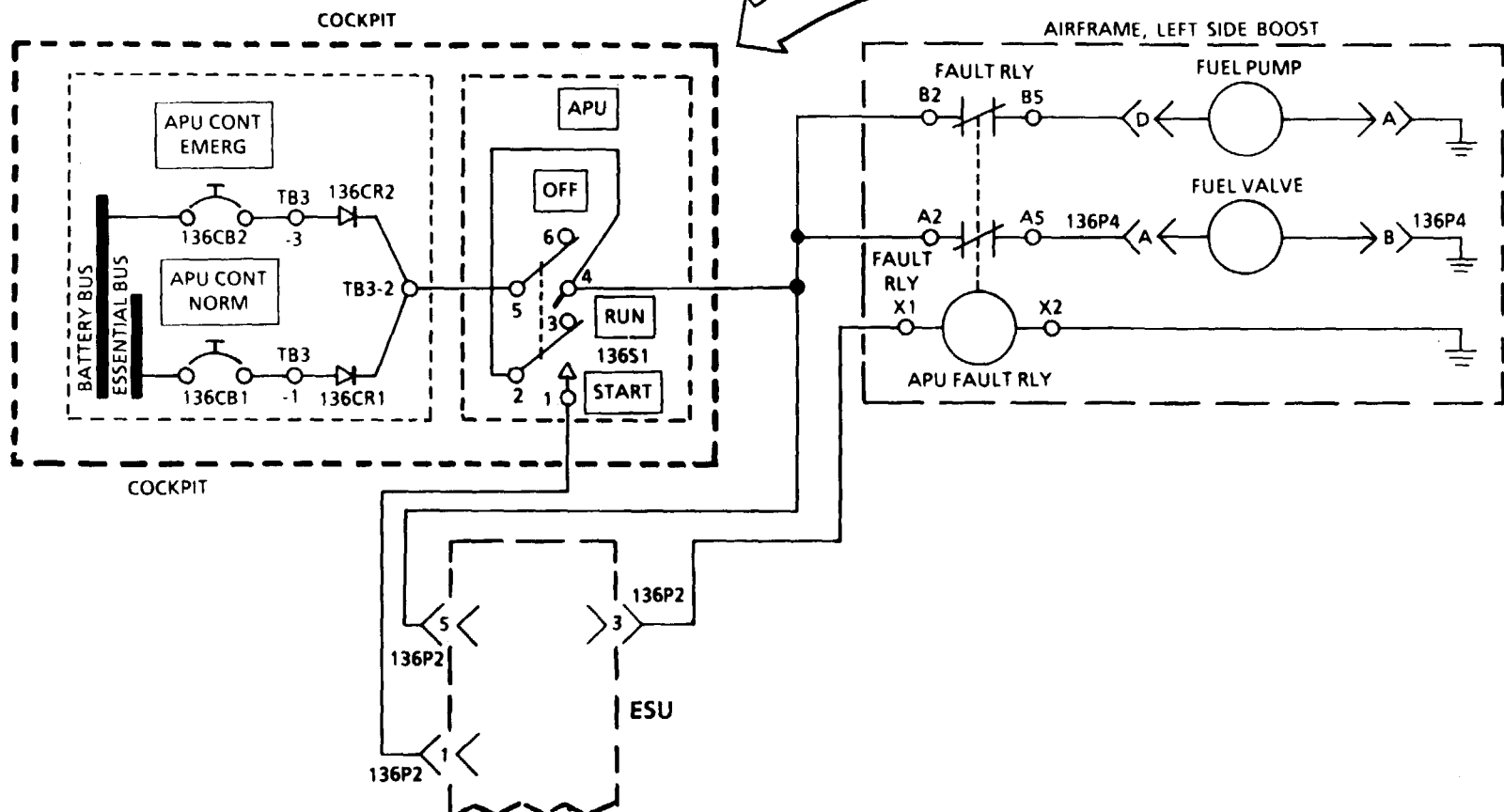
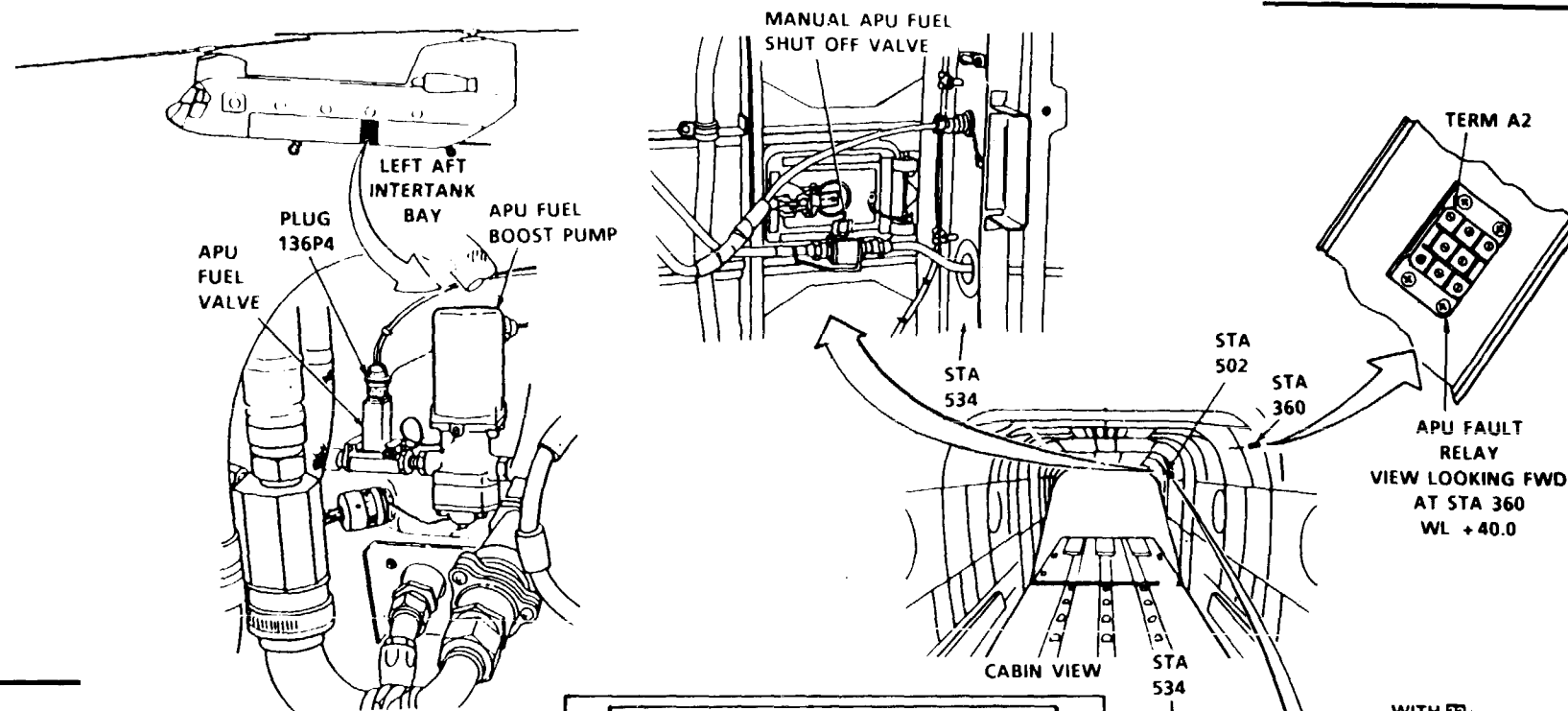

GO TO NEXT PAGE

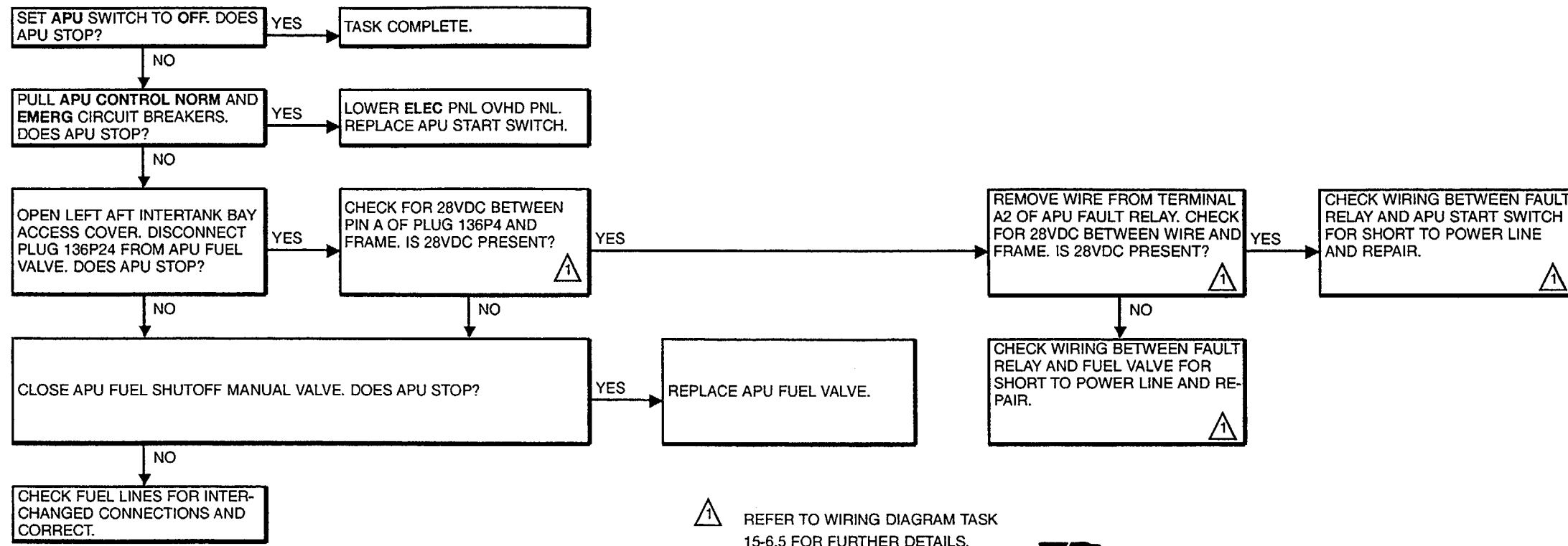

⚠ REFER TO WIRING DIAGRAM TASK 15-6.5 FOR FURTHER DETAILS. 

15-2.13 APU ON CAPSULE OUT WHEN APU OPERATING NORMALLY

FAULT ISOLATION PROCEDURE

INITIAL SETUP

Applicable Configurations:
All

Tools: Equipment Condition:

Electrical Repairer's Tool Kit,
NSN 5180-00-323-4915
Multimeter

Materials

None

Personnel Required:

Aircraft Electrician (2)

References:

TM 55-1520-240-23
TM 55-1500-343-23

TM 55-1520-240-23
Battery Connected
Electrical Power On
Hydraulic Power Off

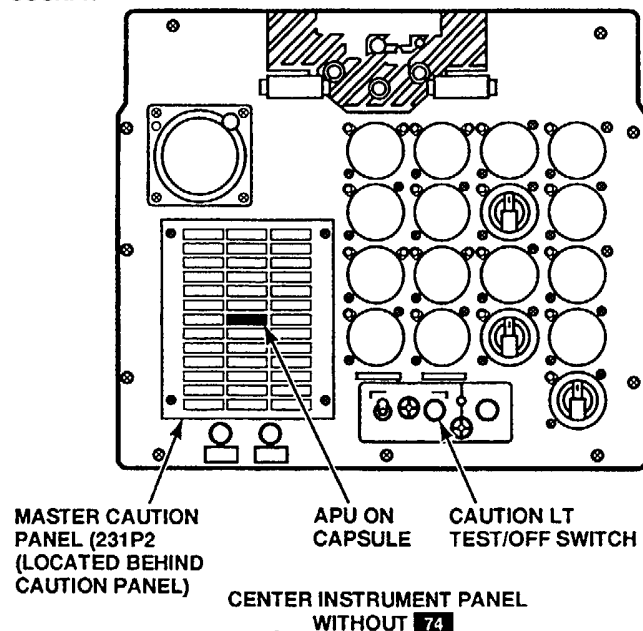
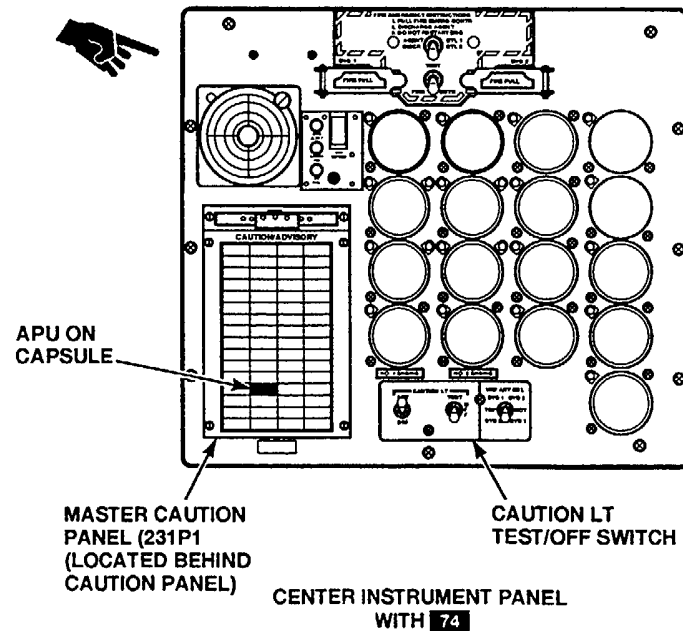
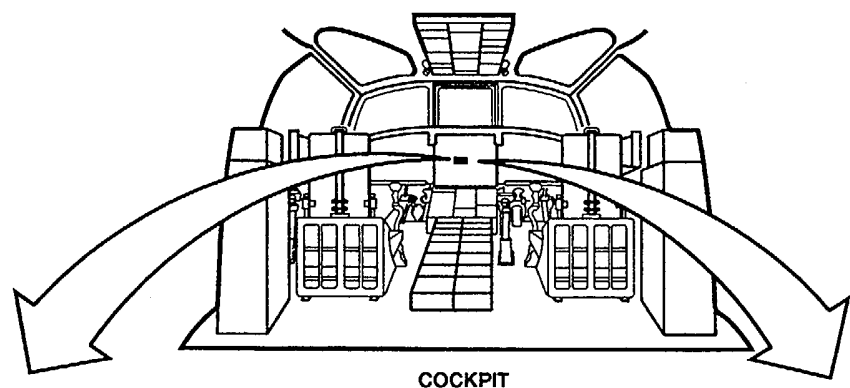
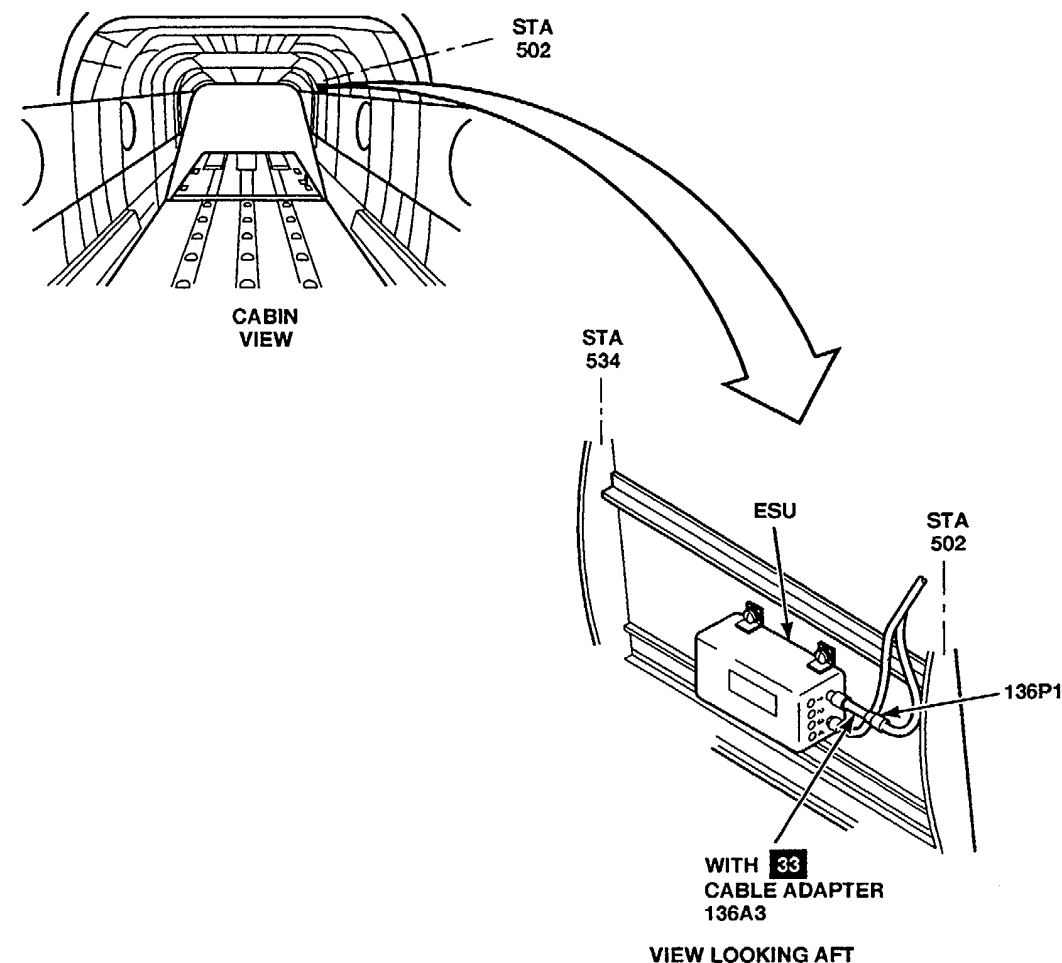

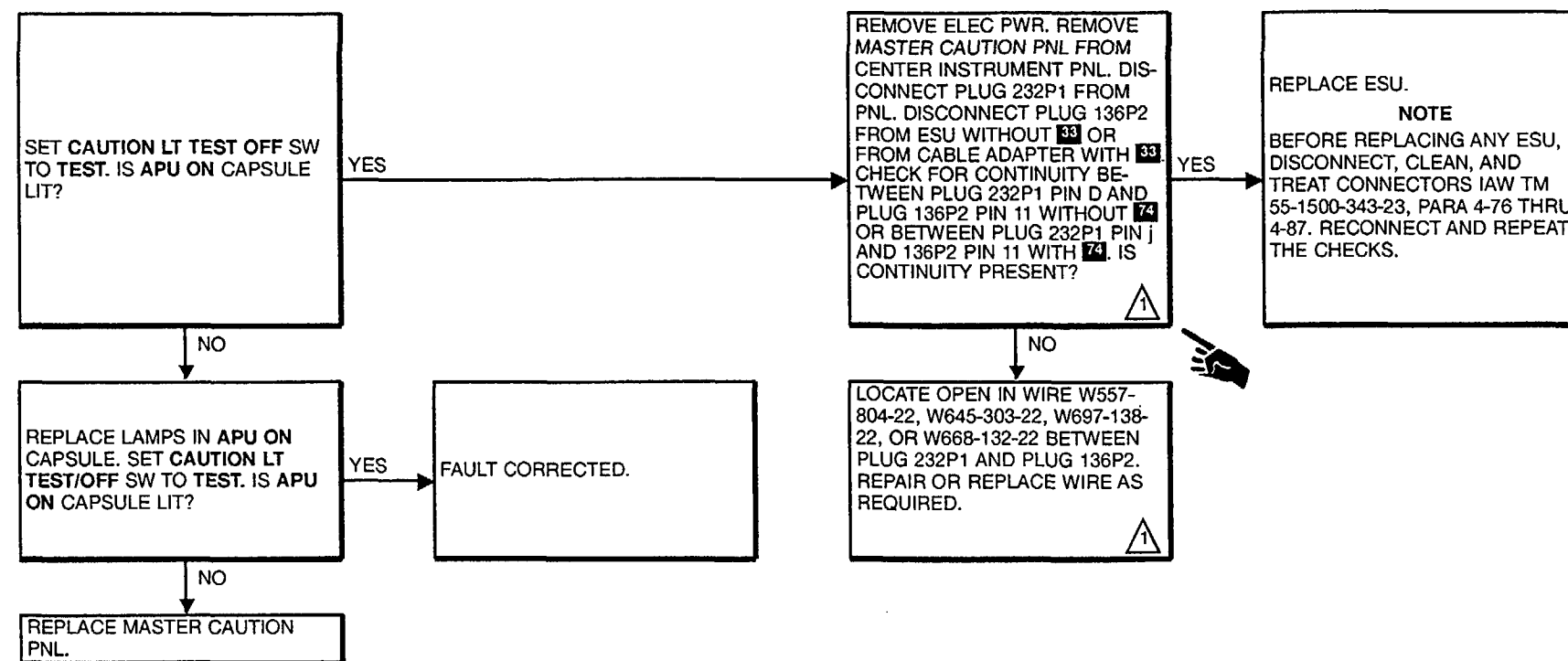

REFER TO WIRING DIAGRAM IN TASK 15-6.5 FOR FURTHER DETAILS.

15-2.14 APU SHUTS DOWN WHEN GEN APU SWITCH PLACED TO ON.

15-2.14

ESU BITE INDICATES ●●●● (READY FOR SERVICE)

FAULT ISOLATION PROCEDURE

INITIAL SETUP

Applicable Configurations:
All

Tools:
Electrical Repairer's Tool Kit.
NSN 5180-00-323-4915
Multimeter

Materials:
None

Personnel Required:
Aircraft Electrician

References:
TM 55-1520-240-23

Equipment Condition:
TM 55-1520-240-23:
Battery Connected
Electrical Power On
Hydraulic Power Off

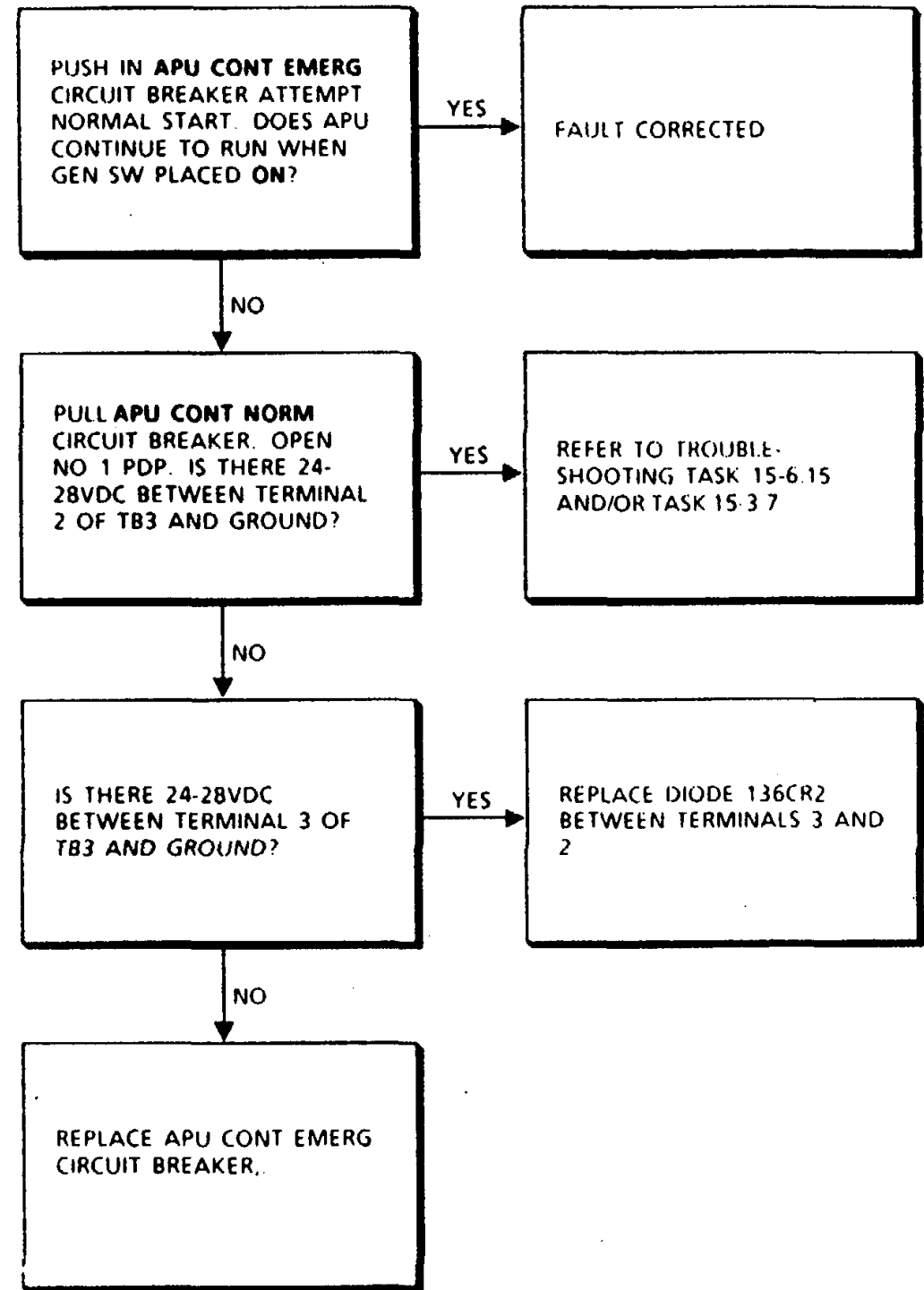
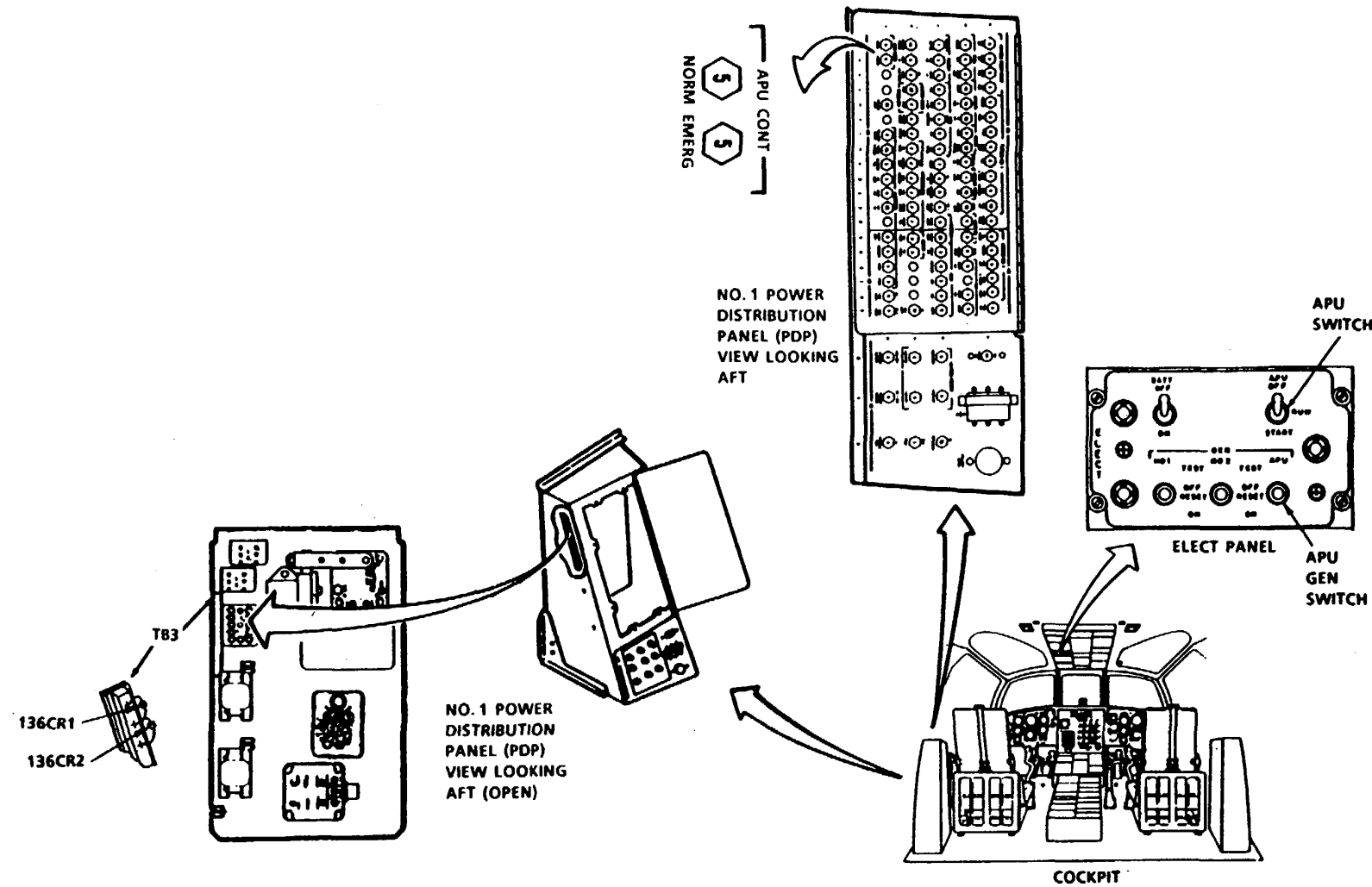

END OF TASK

**15-2.15 APU SHUTS DOWN WHEN APU GEN SWITCH IS SET TO OFF.
ESU BITE INDICATES** ● ● ● ●

FAULT ISOLATION PROCEDURE

INITIAL SETUP

Personnel Required:

Aircraft Electrician

Applicable Configurations:

All

Tools:

Electrical Repairer's Tool Kit,

NSN 5180-00-323-4915

Multimeter

Materials:

None

References:

TM 55-1520-240-23

TM 55-1500-343-23

Equipment Condition:

TM 55-1520-240-23:

Battery Connected

Electrical Power On

Hydraulic Power Off

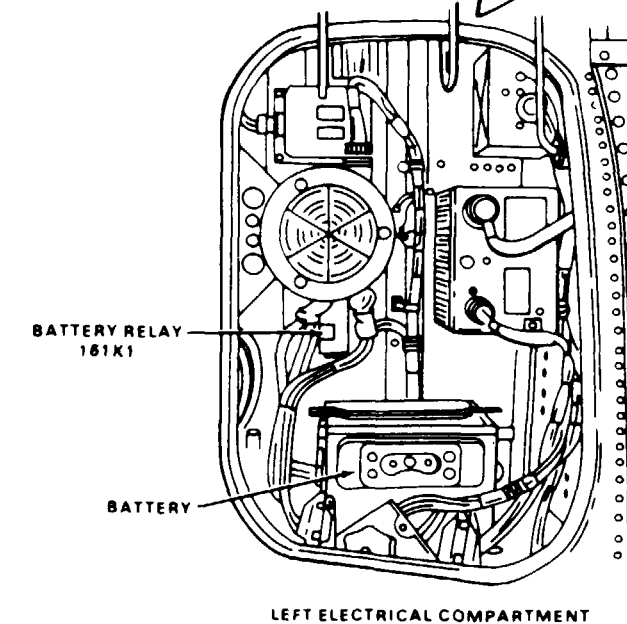
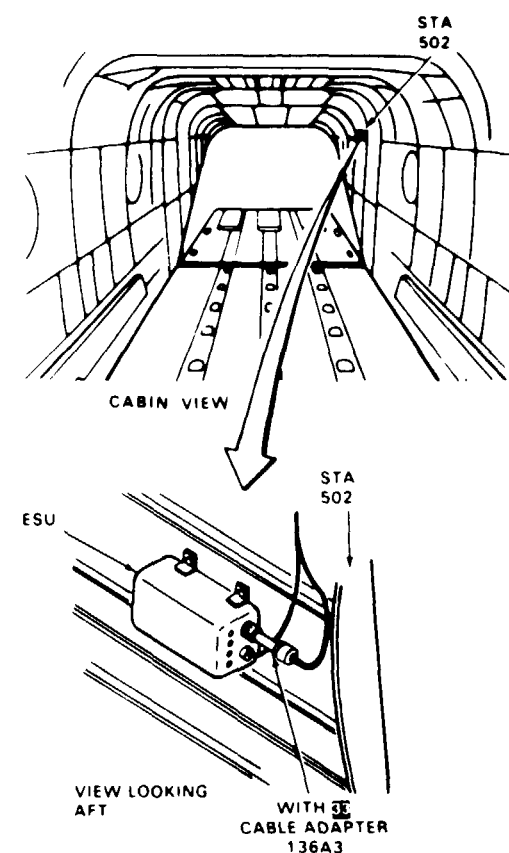
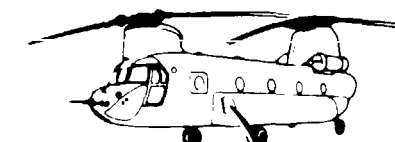
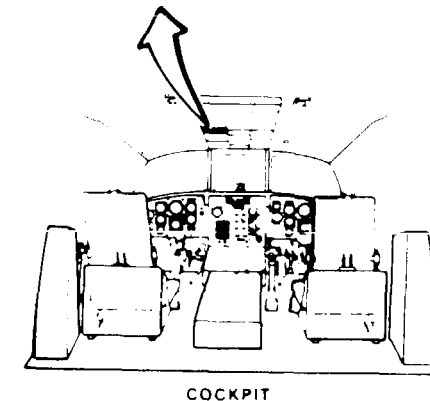
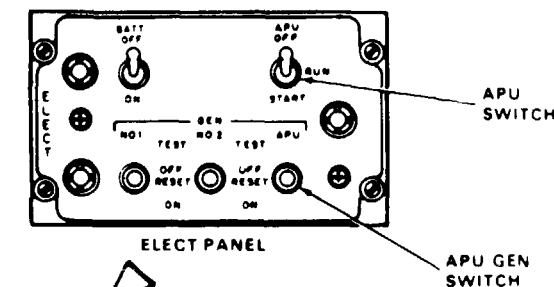
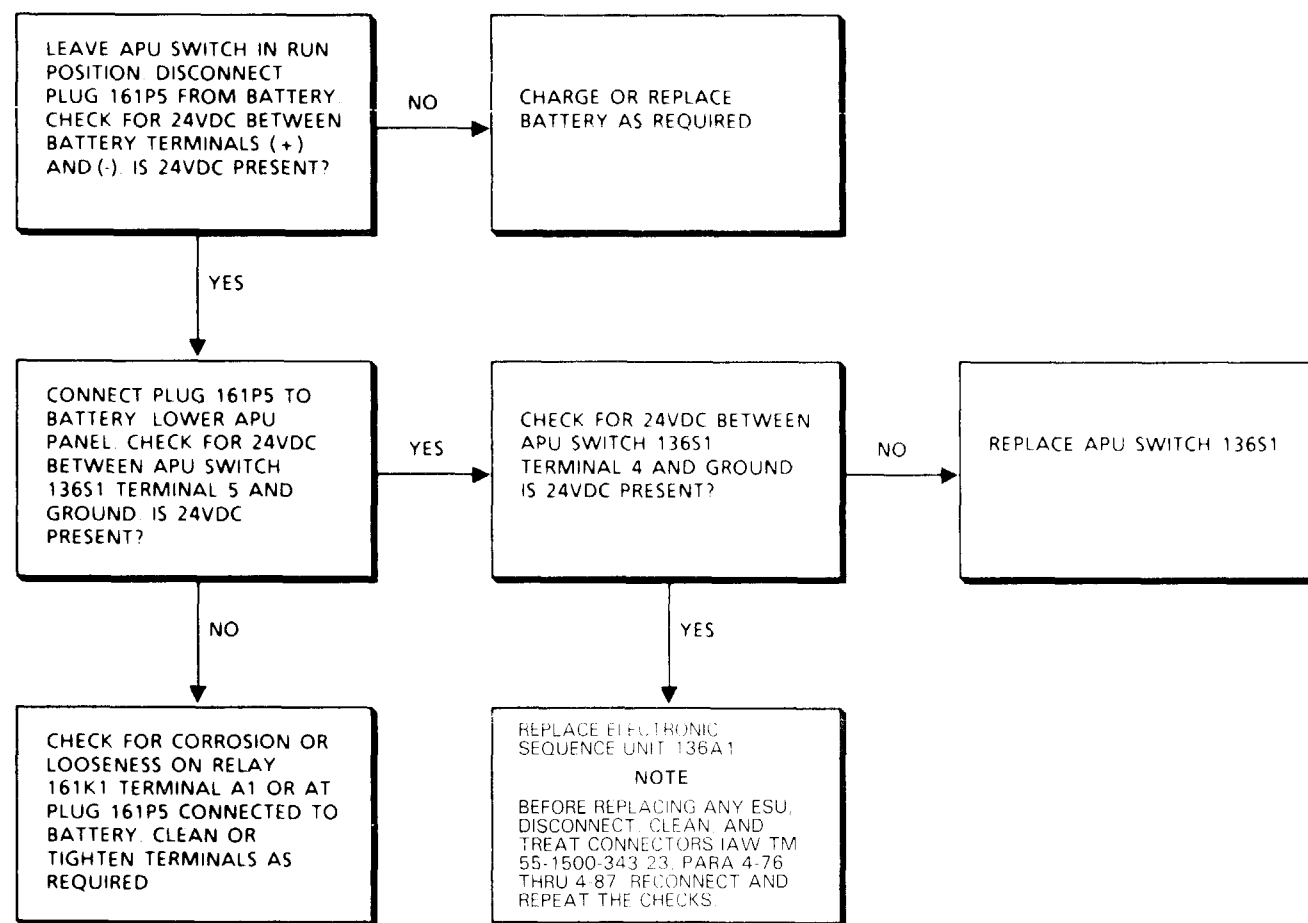

END OF TASK

15-3 APU FUEL SYSTEM

PARAGRAPH 15-3
 TABLE OF CONTENTS
 APU FUEL SYSTEM TROUBLESHOOTING

PARAGRAPH	DESCRIPTION	FUNCTION	PAGE
15-3	APU FUEL SYSTEM		15-49
15-3.1	APU FUEL SYSTEM COMPONENTS	DRAWING	15-53
15-3.2	APU FUEL SYSTEM BLOCK DIAGRAM	DRAWING	15-54
15-3.3	APU FUEL SYSTEM PIPING DIAGRAM	DRAWING	15-55
15-3.4	APU FUEL SYSTEM ELECTRICAL SCHEMATIC	DRAWING	15-56
15-3.5	APU FUEL SYSTEM WIRING DIAGRAM	DRAWING	15-57
15-3.6	APU MOTORS BUT DOES NOT START, ESU BITE INDICATES ○○●● THEN ●○○● (FAILURE TO START)	TASK	15-58
15-3.7	APU MOTORS BUT DOES NOT START, ESU BITE INDICATES ○○○● THEN ●○○● (FAILURE TO START)	TASK	15-60
15-3.8	APU FUEL BOOST PUMP AND FUEL VALVE ELECTRICAL TESTS	TABLE	15-62
15-3.9	APU FAULT RELAY ELECTRICAL TESTS	TABLE	15-63
15-3.10	APU START FUEL AND MAIN FUEL VALVES ELECTRICAL TESTS	TABLE	15-64

LIST OF TABLES

TABLE NO.	DESCRIPTION	PAGE NO.
15-3.1	APU FUEL BOOST PUMP AND FUEL SOLENOID VALVE - ELECTRICAL TESTS	15-62
15-3.2	APU FAULT RELAY - ELECTRICAL TESTS	15-63
15-3.3	APU START FUEL AND MAIN FUEL VALVES ELECTRICAL TESTS	15-64

15-3 APU FUEL SYSTEM

15-3.1 APU FUEL SYSTEM COMPONENTS

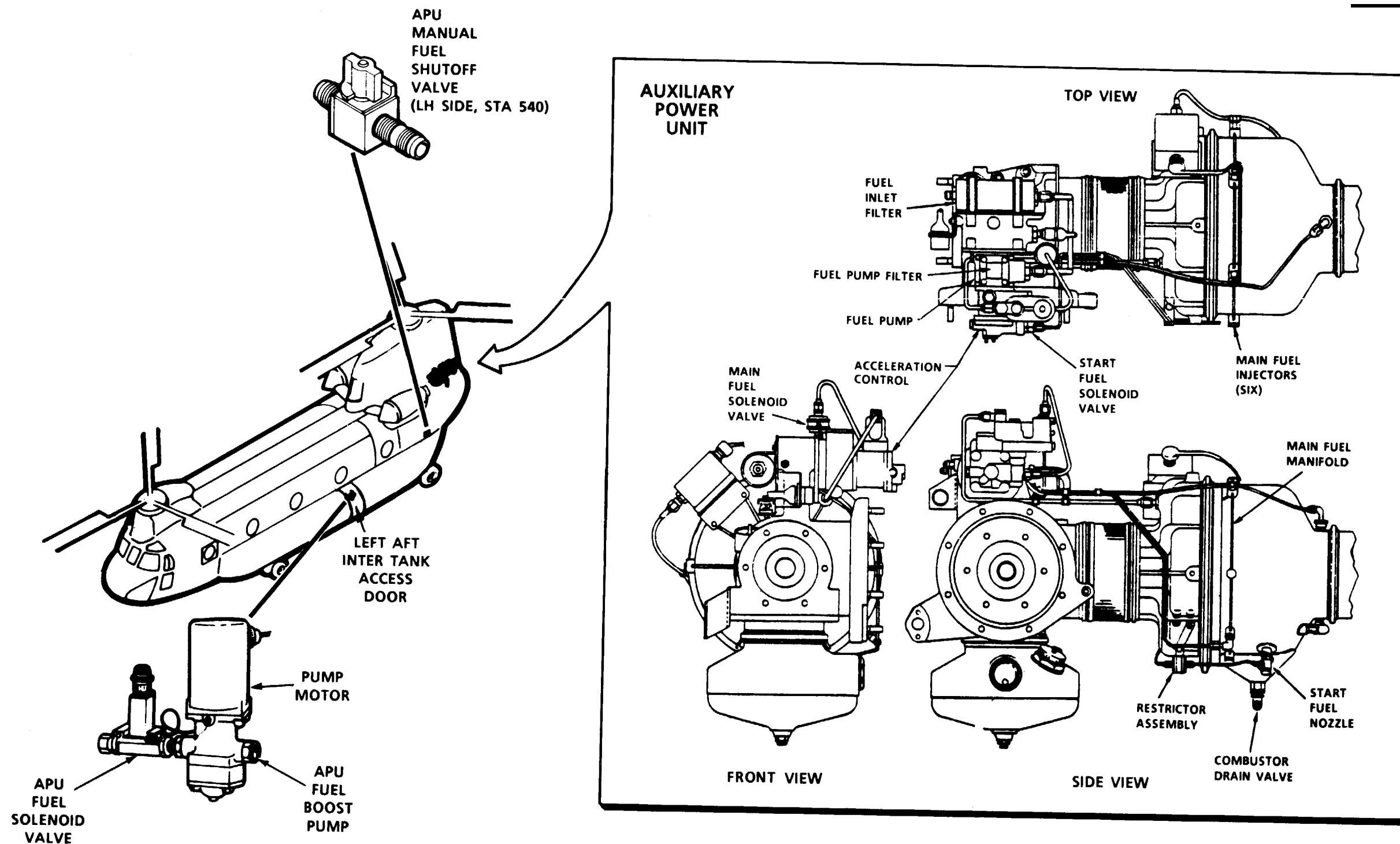

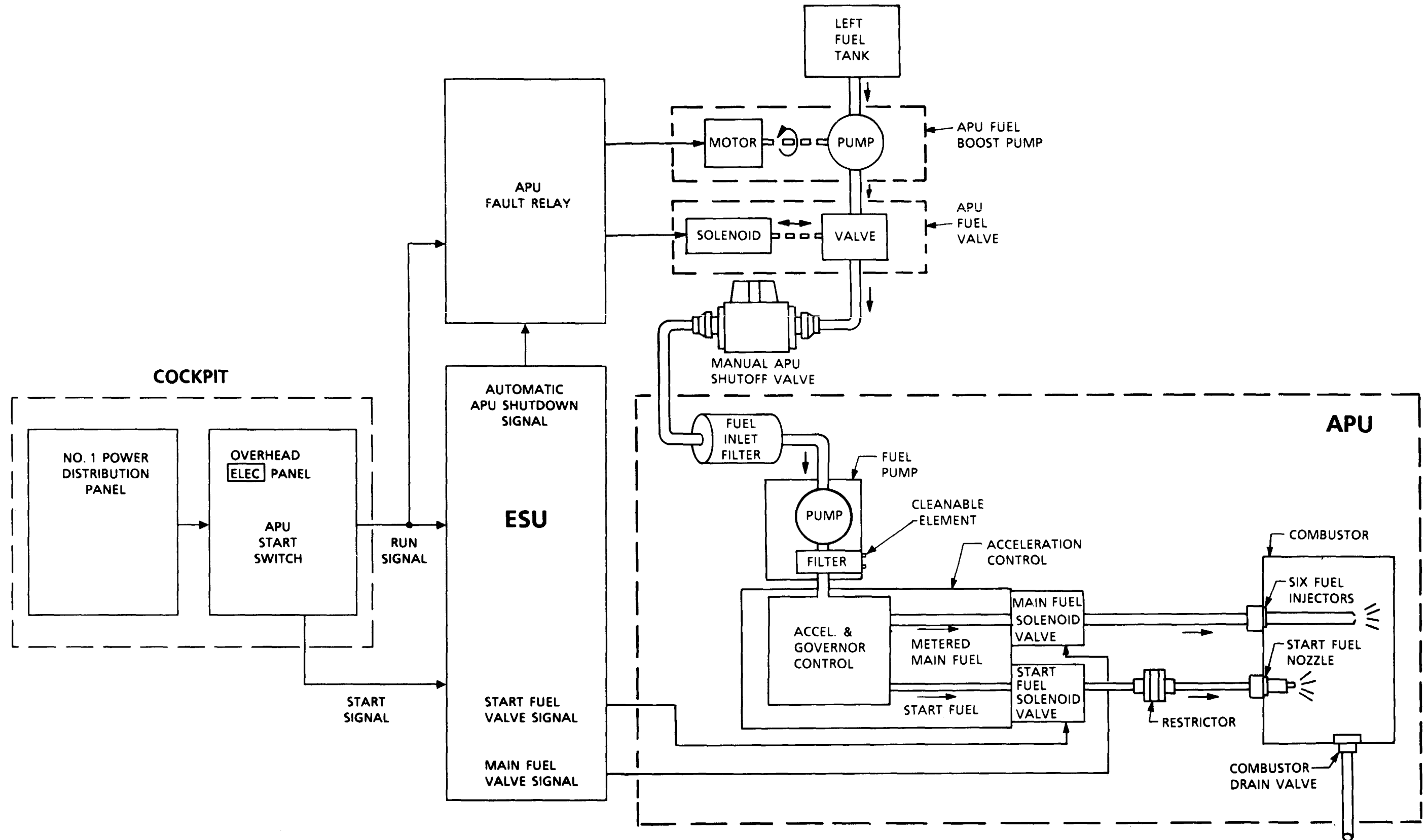

15-3.3 APU FUEL SYSTEM PIPING DIAGRAM

NOTES

- 1 WIRES TO J301 (MAGNETIC PICKUP WIRE)
- 2 ONLY PLUMBING RELATED TO APU FUEL
- 3 REFER TO TASK 15-3.10

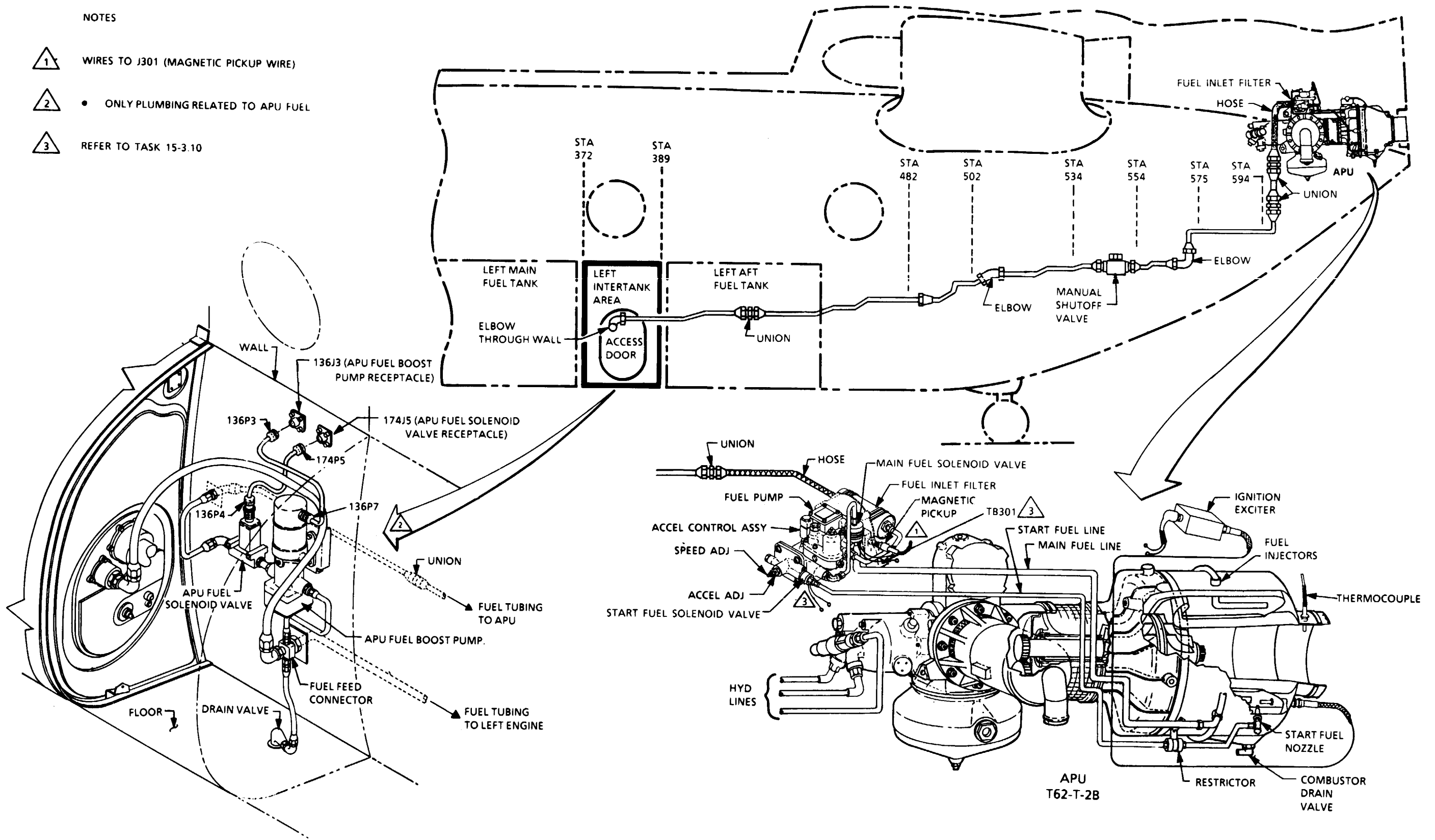

15-3.4 APU FUEL SYSTEM ELECTRICAL SCHEMATIC

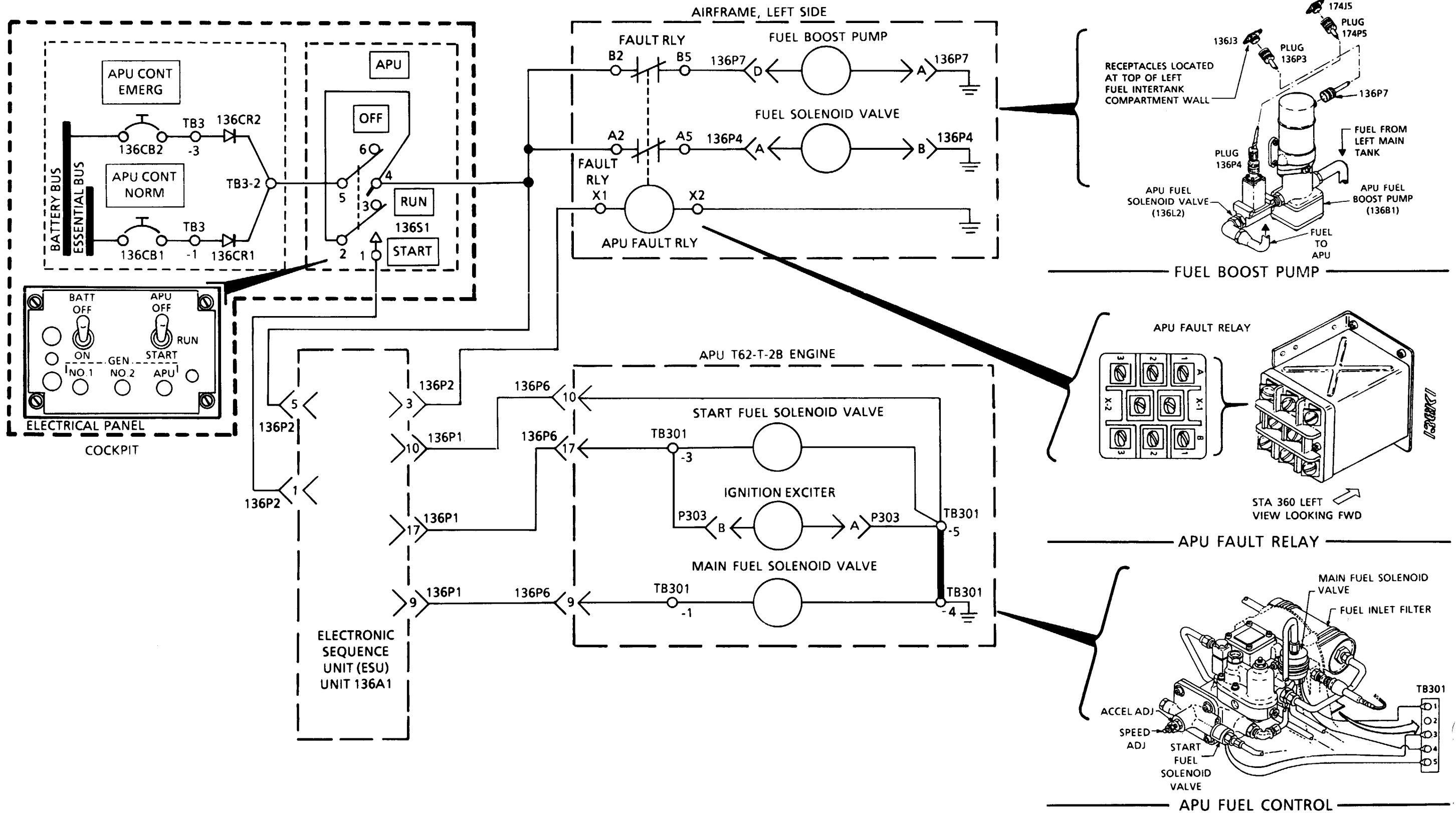

15-3.5 APU FUEL SYSTEM WIRING DIAGRAM

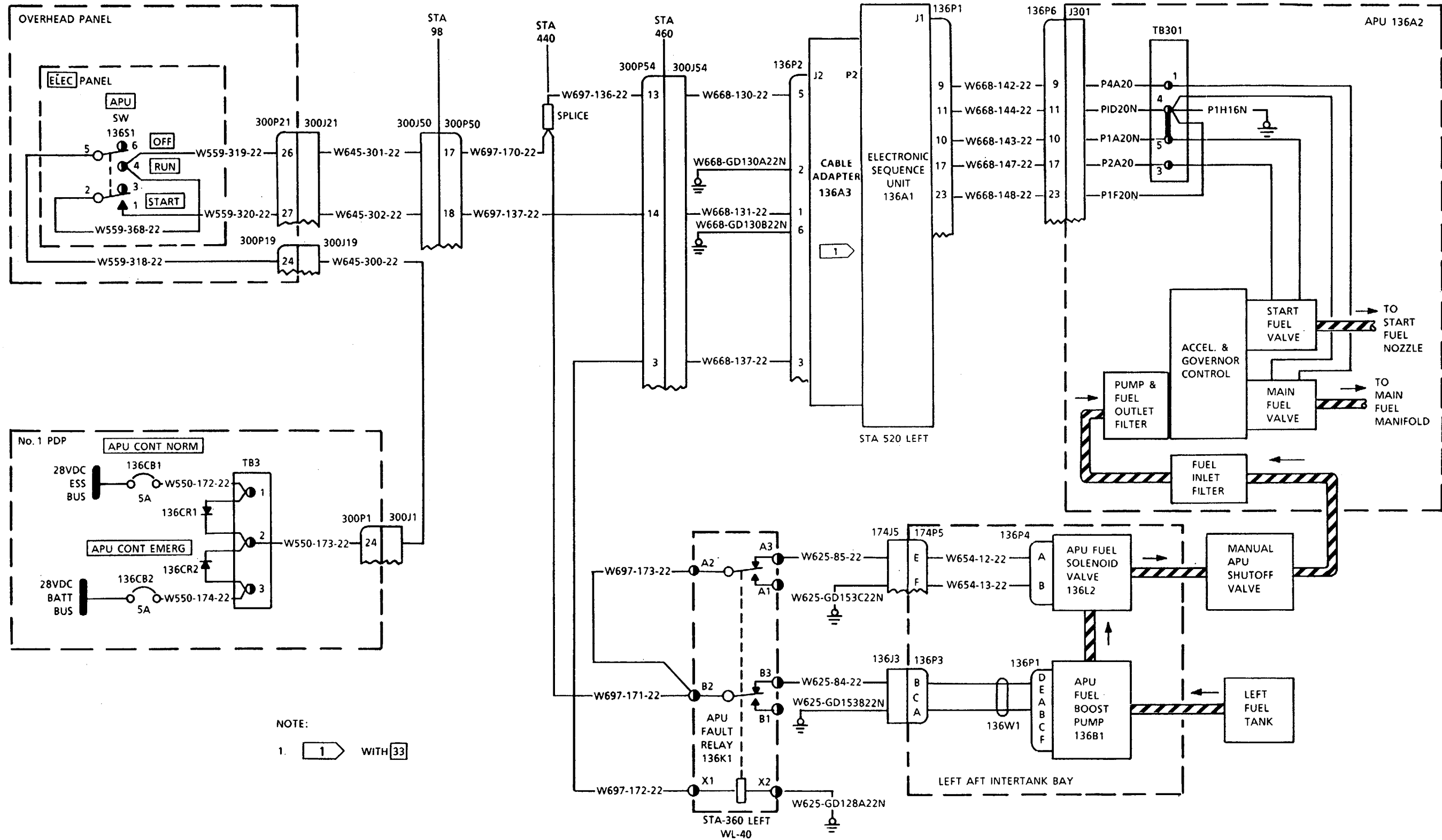

15-3.6 APU MOTORS BUT DOES NOT START, ESU BITE INDICATES ○ ○ ● ● THEN ● ○ ○ ● (FAILURE TO START; FUEL SYSTEM)

FAULT ISOLATION PROCEDURE

INITIAL SETUP

Applicable Configurations:

All

Tools:

- Aircraft Mechanic's Tool Kit, NSN 5180-00-323-4692
- Electrical Repairer's Tool Kit, NSN 5180-00-323-4915
- Multimeter

Materials:

- Cloth (E120)
- Tape (E385)

Personnel Required:

- Aircraft Electrician
- Medium Helicopter Repairer

References:

TM 55-1520-240-23

TM 55-2835-205-23

Equipment Condition:

- TM 55-1520-240-23
- Battery Connected
- Electrical Power On
- Hydraulic Power Off

General Safety Instructions

WARNING

All regulations and instructions for handling fuels shall be strictly observed.

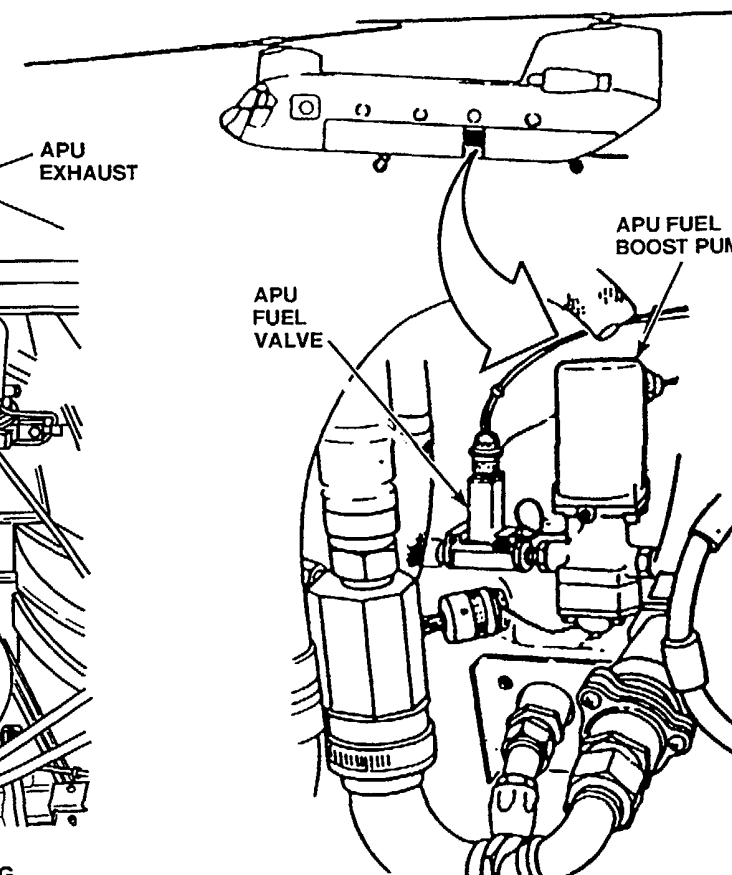
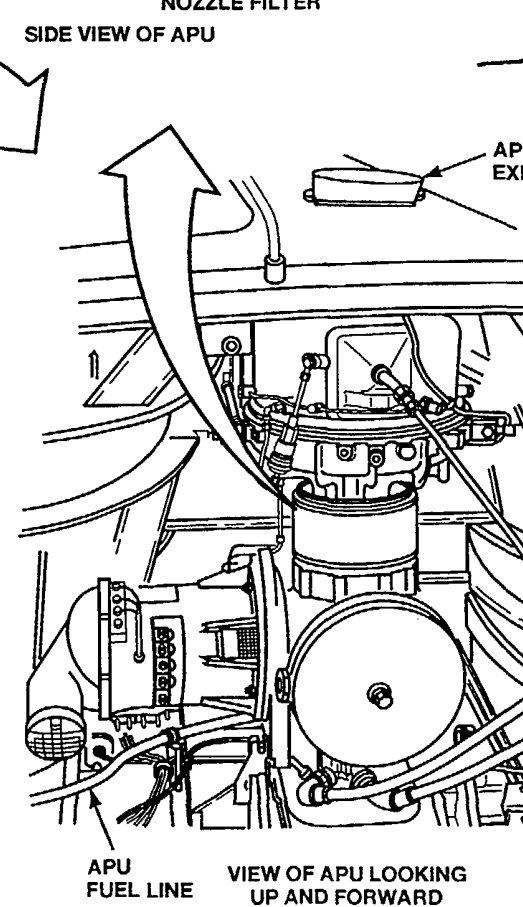
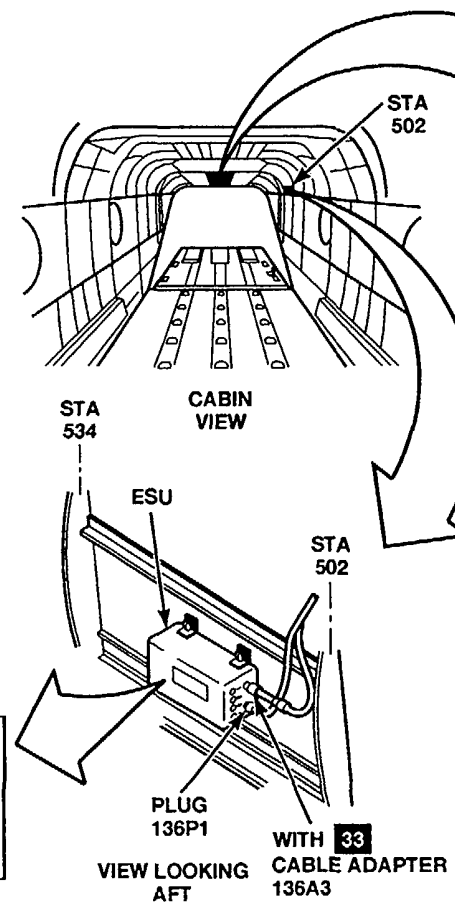
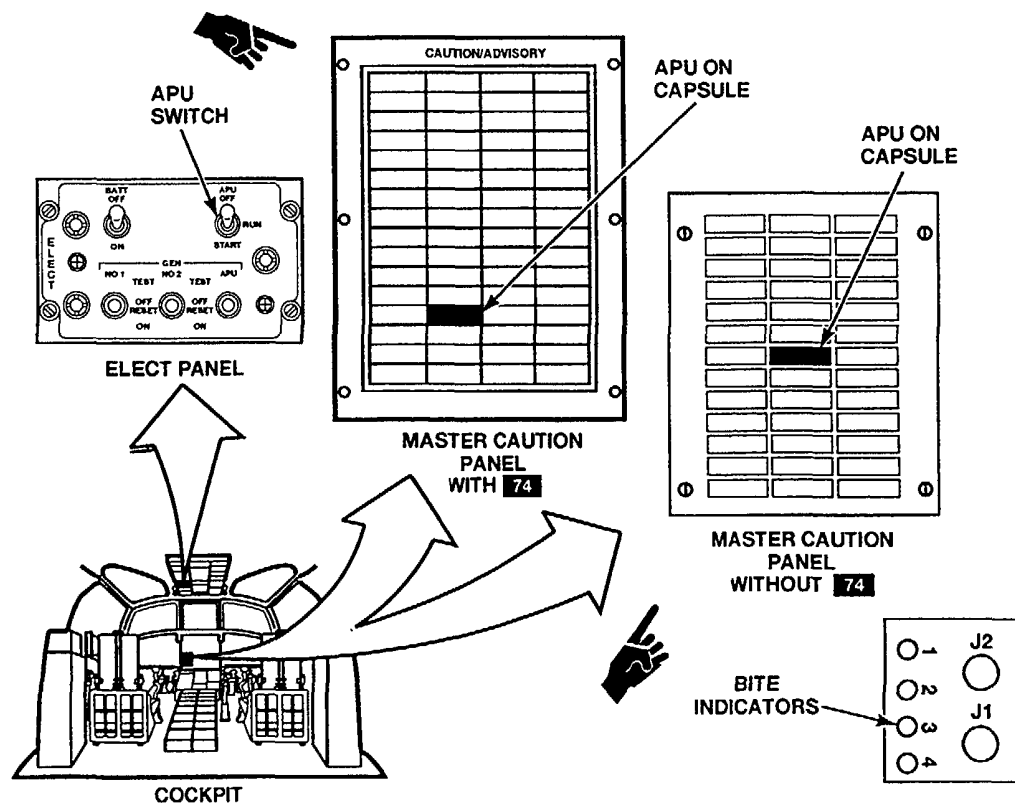
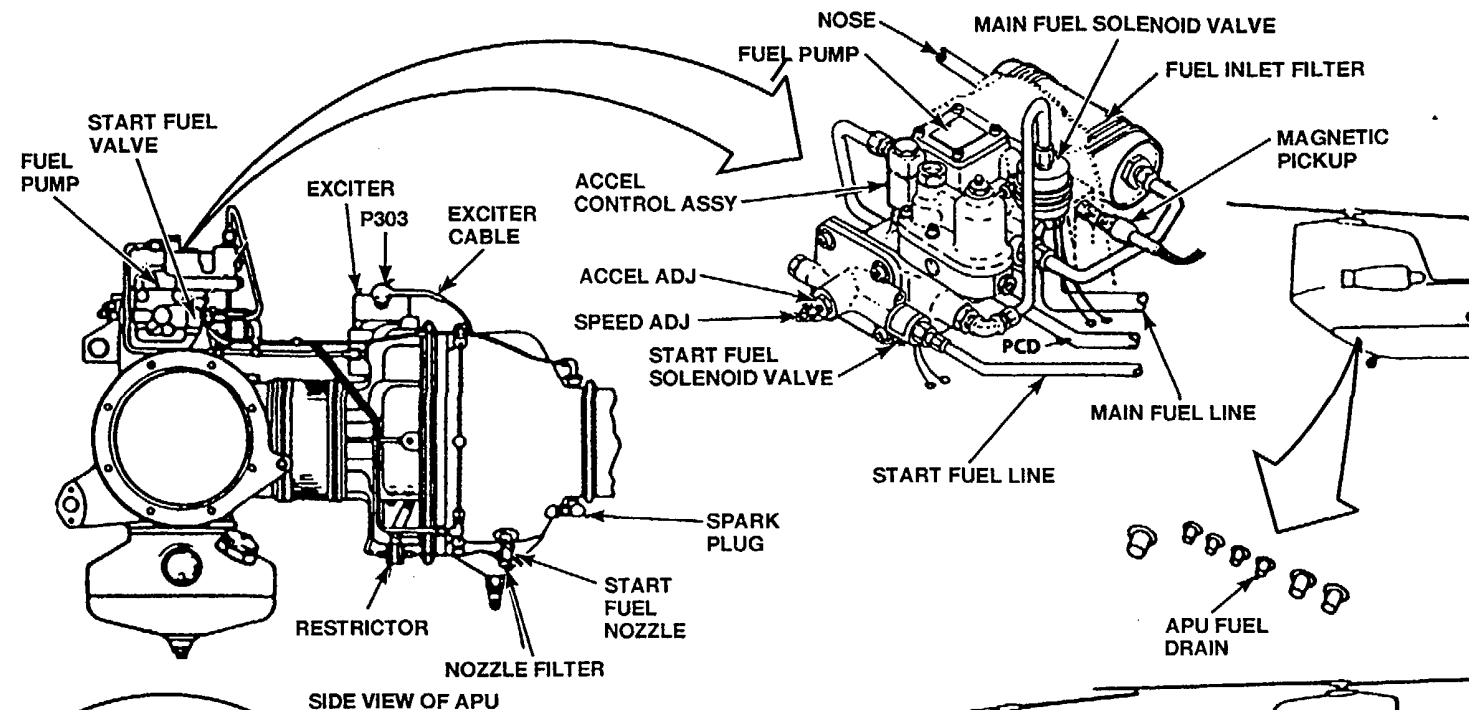

A65510

GO TO NEXT PAGE

15-3.6 APU MOTORS BUT DOES NOT START, ESU BITE INDICATES

○ ○ ● ● THEN ● ○ ○ ● (CONTINUED ; FUEL SYSTEM)

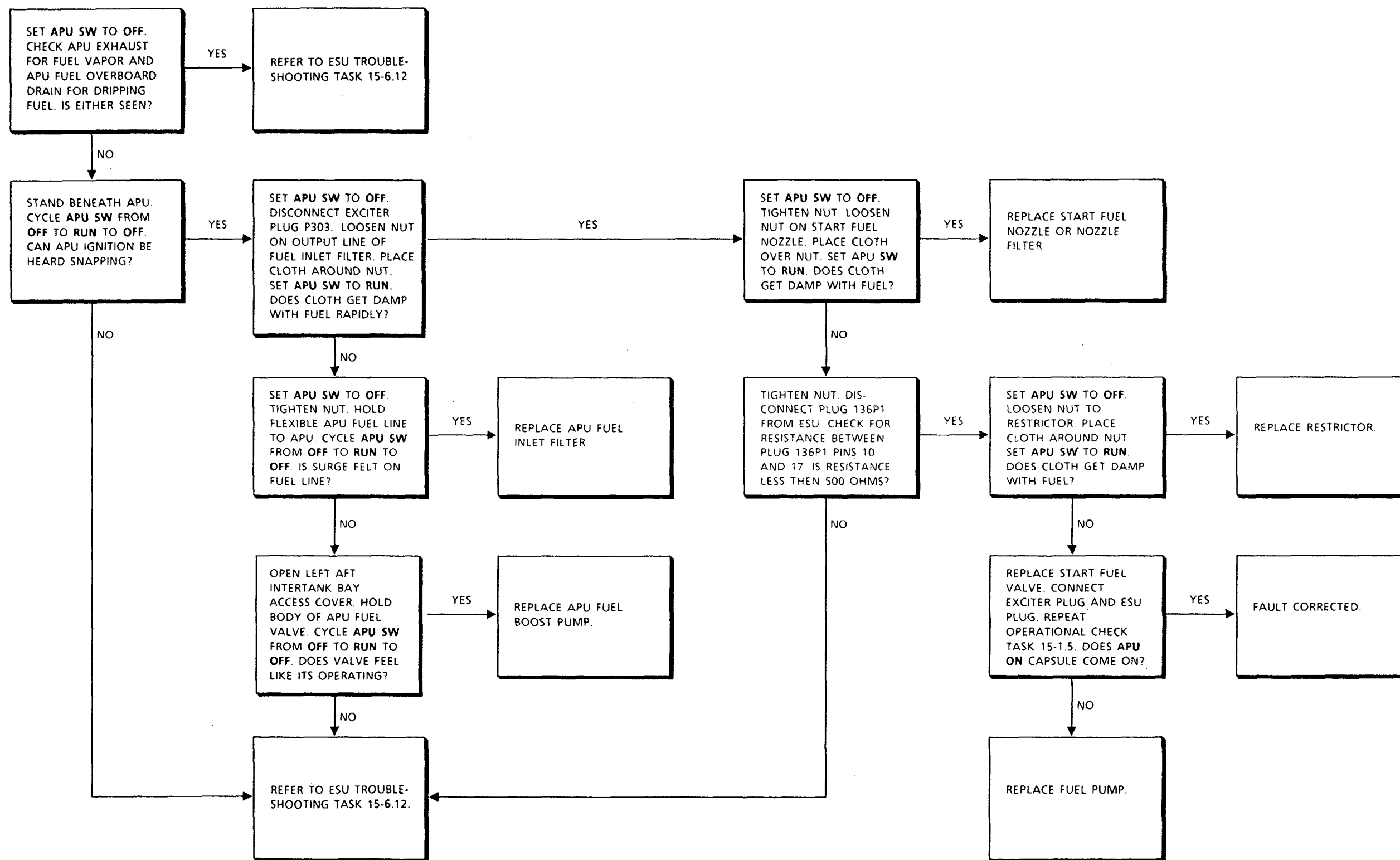

15-3.7 APU MOTORS BUT DOES NOT START, ESU BITE INDICATES ○ ○ ○ ● THEN ● ○ ○ ● (FAILURE TO START)

FAULT ISOLATION PROCEDURE

INITIAL SETUP

TM 55-2835-205-23

Applicable Configurations

All

Tools:

- Aircraft Mechanic's Tool Kit, NSN 5180-00-323-4692
- Electrical Repairer's Tool Kit, NSN 5180-00-323-4915
- Multimeter

Materials:

None

Personnel Required:

- Aircraft Electrician
- Medium Helicopter Repairer

References

TM 55-1520-240-23

Equipment Condition:

TM 55-1520-240-23

Battery Connected

Electrical Power On

Hydraulic Power Off

General Safety Instructions

WARNING

All regulations and instructions for handling fuels shall be strictly observed.

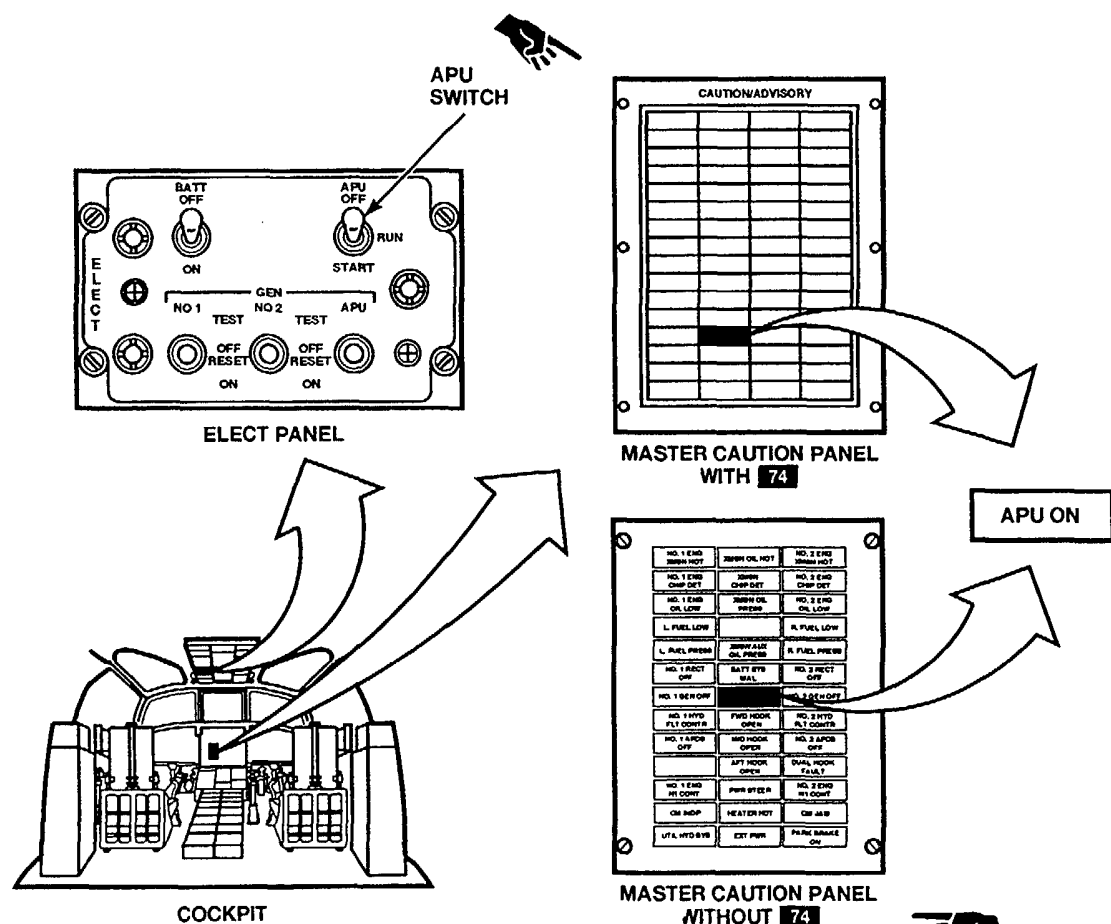
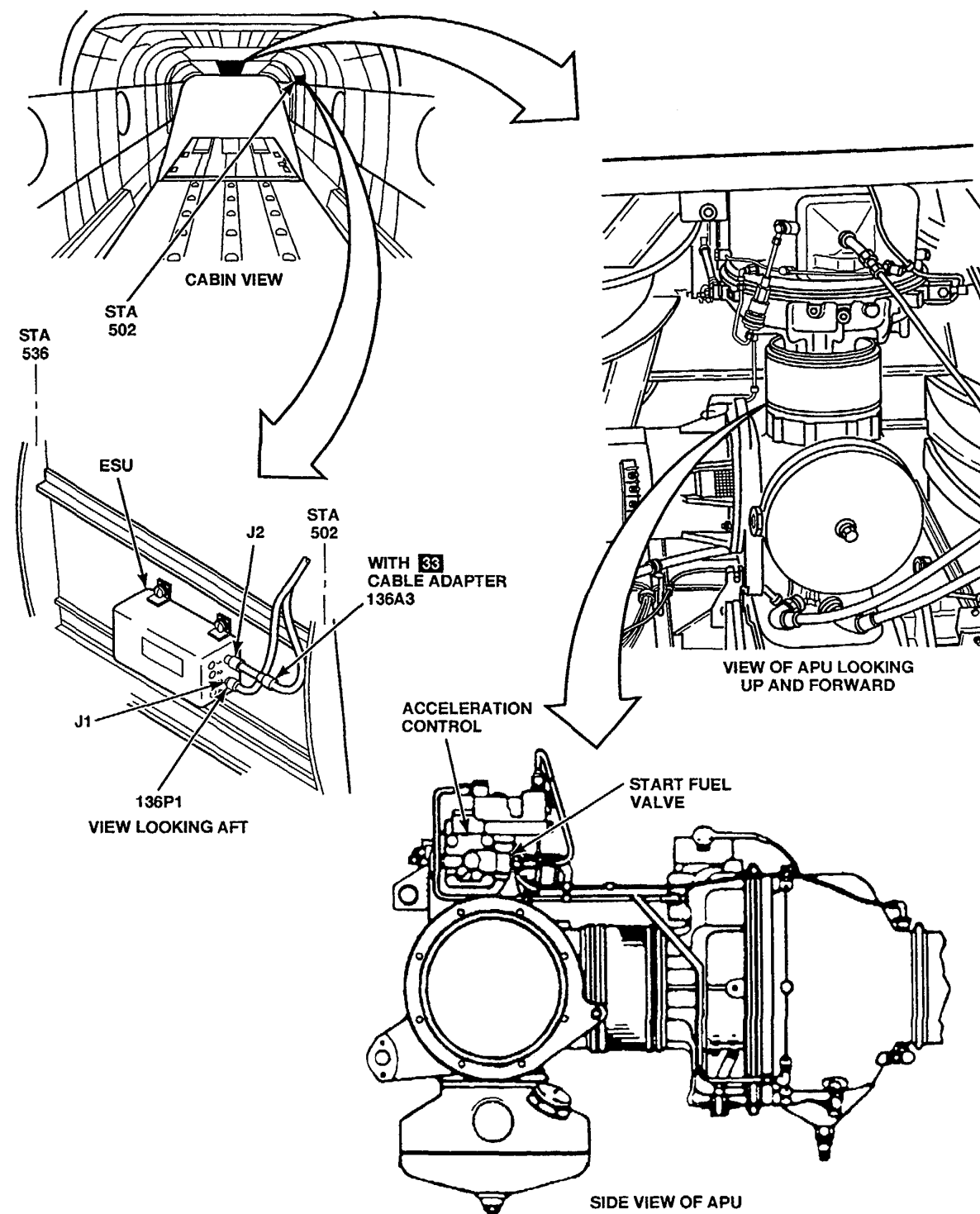

GO TO NEXT PAGE
15-60 Change 23

15-3.7 APU MOTORS BUT DOES NOT START, ESU BITE INDICATES ○ ○ ○ ● THEN ● ○ ○ ● (CONTINUED)

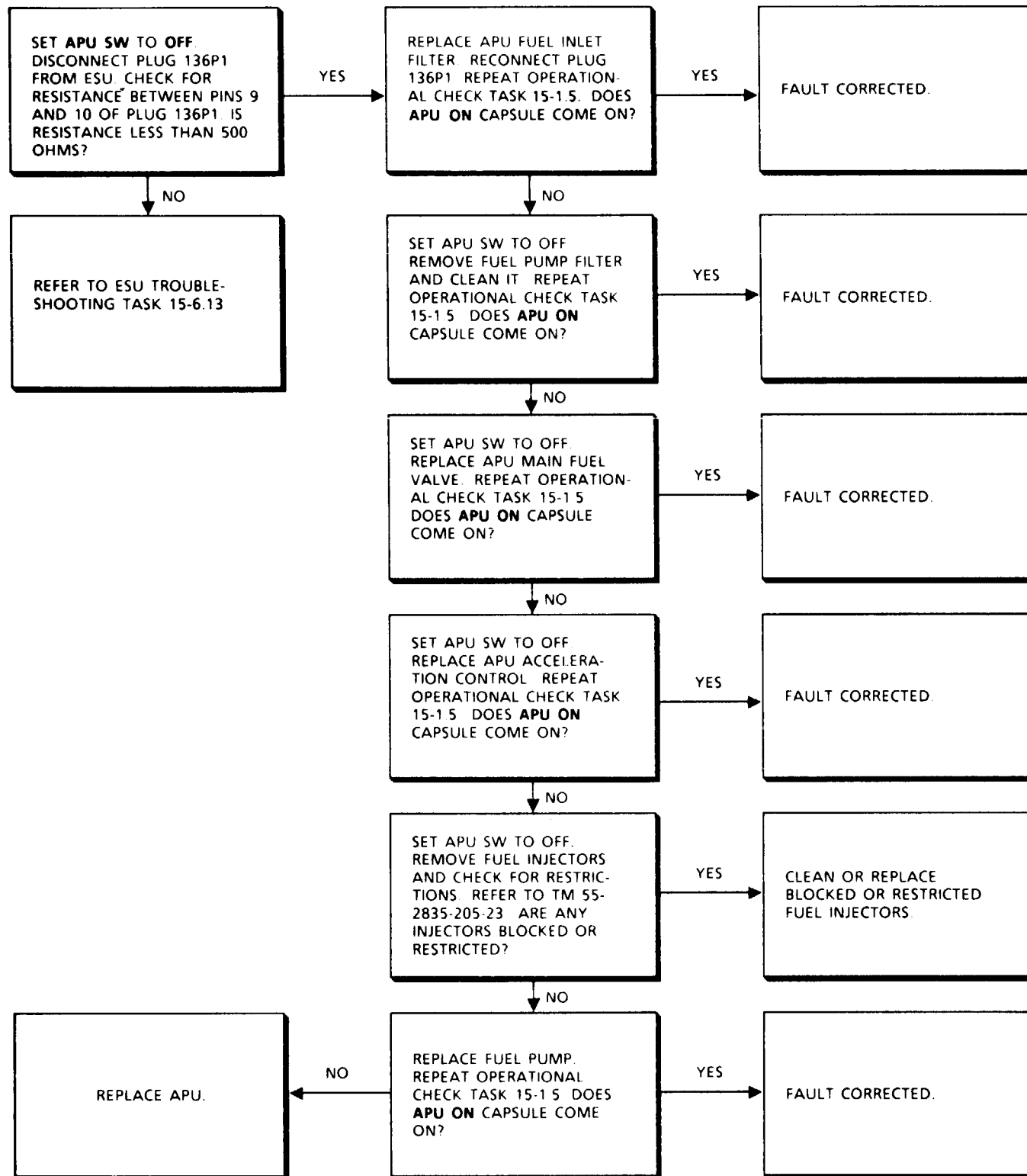

END OF TASK

15-3.8 APU FUEL BOOST PUMP AND FUEL VALVE ELECTRICAL TESTS

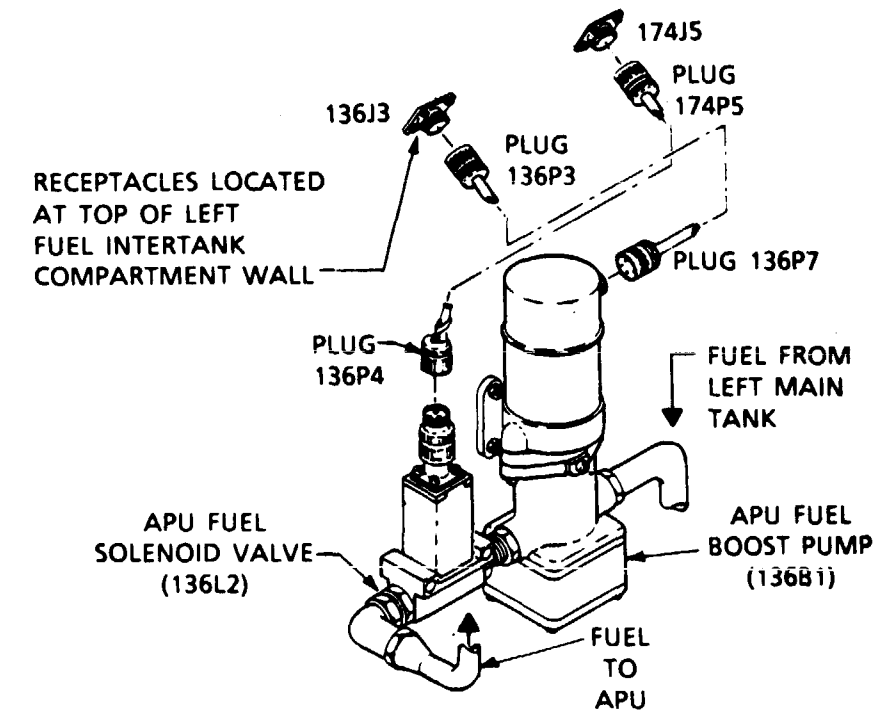
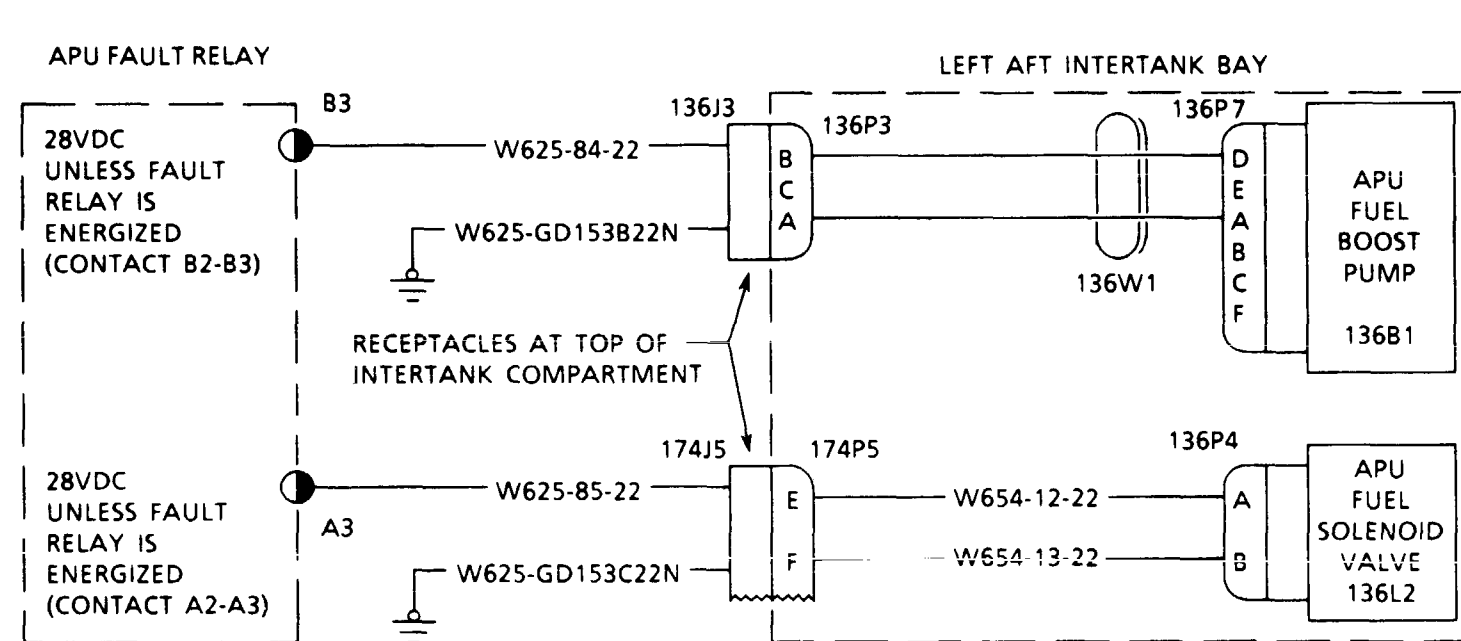

TABLE NO. 15-3.1 - APU FUEL BOOST PUMP AND FUEL SOLENOID VALVE - ELECTRICAL TESTS

TYPE OF TEST	TEST CONDITION	PROCEDURE	METER READING OR TEST RESULTS
RESISTANCE CHECK OF APU FUEL BOOST PUMP.	APU SWITCH TO OFF.	<ol style="list-style-type: none"> 1. OPEN AFT FUEL INTERTANK BAY DOOR. 2. DISCONNECT PLUG 136P3 (AT TOP RIGHT SIDE OF COMPARTMENT). 3. MEASURE RESISTANCE BETWEEN PINS A AND B ON 136P3. 4. RECONNECT 136P3 TO 136J3. 	15 OHMS
RESISTANCE CHECK OF APU FUEL SOLENOID VALVE.	APU SWITCH TO OFF.	<ol style="list-style-type: none"> 1. OPEN AFT FUEL INTERTANK BAY DOOR. 2. DISCONNECT PLUG 174P5 (AT TOP RIGHT SIDE OF COMPARTMENT). 3. MEASURE RESISTANCE BETWEEN PINS E AND F ON 174P5. 4. RECONNECT 174P5 TO 174J5. 	180-220 OHMS
VOLTAGE CHECK AT APU FUEL BOOST PUMP PLUG.	APU SWITCH TO RUN.	<ol style="list-style-type: none"> 1. BOOST PUMP SHOULD BE HEARD RUNNING AS APU SWITCH IS PLACED TO RUN POSITION. IF NOT, CHECK VOLTAGE. 2. DISCONNECT PLUG AT BOOST PUMP AND MEASURE VOLTAGE BETWEEN PINS D AND A. 3. RECONNECT PLUG TO BOOST PUMP. 	28VDC
VOLTAGE CHECK AT APU FUEL SOLENOID VALVE.	APU SWITCH TO RUN.	<ol style="list-style-type: none"> 1. DISCONNECT PLUG AT APU FUEL BOOST PUMP. 2. DISCONNECT PLUG 136P4 AT APU FUEL SOLENOID VALVE. 3. PLACE APU SWITCH TO RUN AND MEASURE VOLTAGE BETWEEN PINS A AND B OF 136P4. 4. RECONNECT BOTH PLUGS. 	28VDC

15-3.9 APU FAULT RELAY ELECTRICAL TESTS

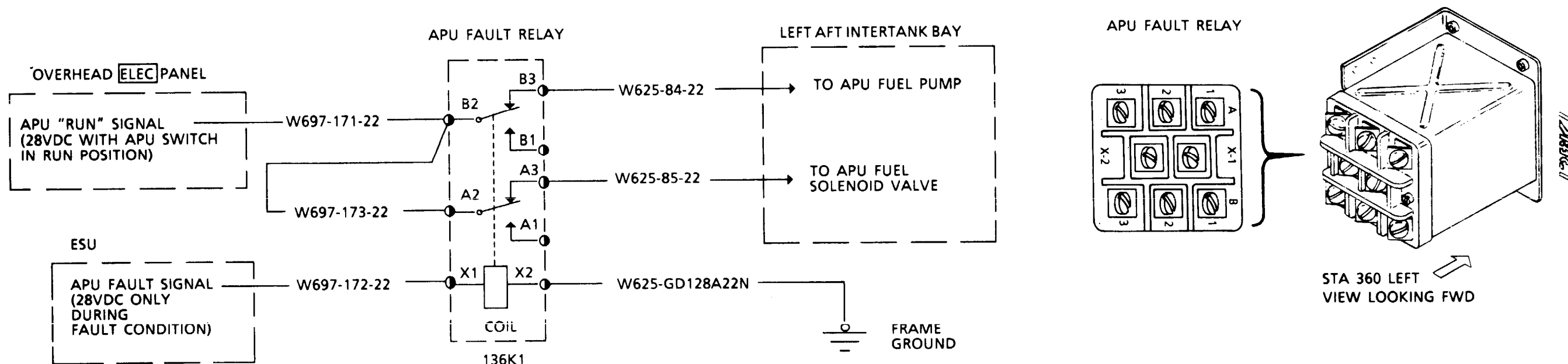

TABLE NO. 15-3.2 – APU FAULT RELAY – ELECTRICAL TESTS

TYPE OF TEST	TEST CONDITION	PROCEDURE	METER READING OR TEST RESULTS
INITIAL SET-UP.	APU SW. TO OFF	1. REMOVE WIRE W625-84-22 FROM B3. 2. REMOVE WIRE W625-85-22 FROM A3. 3. REMOVE WIRE W697-172-22 FROM X1. 4. REMOVE WIRE W697-171-22 FROM B2.	—
B2-B3 CONTACT CHECK WITH ZERO VOLTS ON COIL.	APU SW. TO OFF	PLACE OHMMETER TEST LEADS ACROSS B2 AND B3 AND MEASURE RESISTANCE.	"0" OHMS
A2-B3 CONTACT CHECK WITH ZERO VOLTS ON COIL.	APU SW. TO OFF	PLACE OHMMETER TEST LEADS ACROSS A2 AND A3 AND MEASURE RESISTANCE.	"0" OHMS
COIL RESISTANCE CHECK.	APU SW. TO OFF	PLACE OHMMETER TEST LEADS ACROSS X1 AND X2 AND MEASURE RESISTANCE.	150 OHMS
VOLTAGE TO RELAY CONTACTS CHECK.	APU SW. TO ON	PLACE VOLTMETER TEST LEADS BETWEEN FRAME GROUND AND WIRE W697-171-22 (WHICH WAS REMOVED FROM B2).	28 VDC
RELAY COIL CHECK.	APU SW. TO ON	PLACE JUMPER CLIP LEADS BETWEEN WIRE W697-171-22 AND X1.	RELAY COIL "CLICK" SHOULD BE HEARD.
B2-B3 CONTACT CHECK WITH VOLTAGE ON COIL.	APU SW. TO ON	RETAIN JUMPER BETWEEN WIRE W697-171-22 AND X1. MEASURE RESISTANCE ACROSS B2 AND B3.	METER INDICATES "OPEN" CIRCUIT.
A2-B3 CONTACT CHECK WITH VOLTAGE ON COIL.	APU SW. TO ON	RETAIN JUMPER BETWEEN WIRE W697-171-22 AND X1. MEASURE RESISTANCE ACROSS A2 AND A3.	METER INDICATES "OPEN" CIRCUIT.
RETURN OF WIRES TO TERMINALS ON RELAY.	APU SW. TO OFF	1. REMOVE JUMPER. 2. REPLACE WIRE W625-84-22 ON B3. 3. REPLACE WIRE W625-85-22 ON A3. 4. REPLACE WIRE W697-172-22 ON X1. 5. REPLACE WIRE W697-171-22 ON B2. 6. USE WIRING DIAGRAM TO DOUBLE CHECK RELAY WIRING.	—

15-3.10 APU START AND MAIN FUEL VALVES ELECTRICAL TESTS

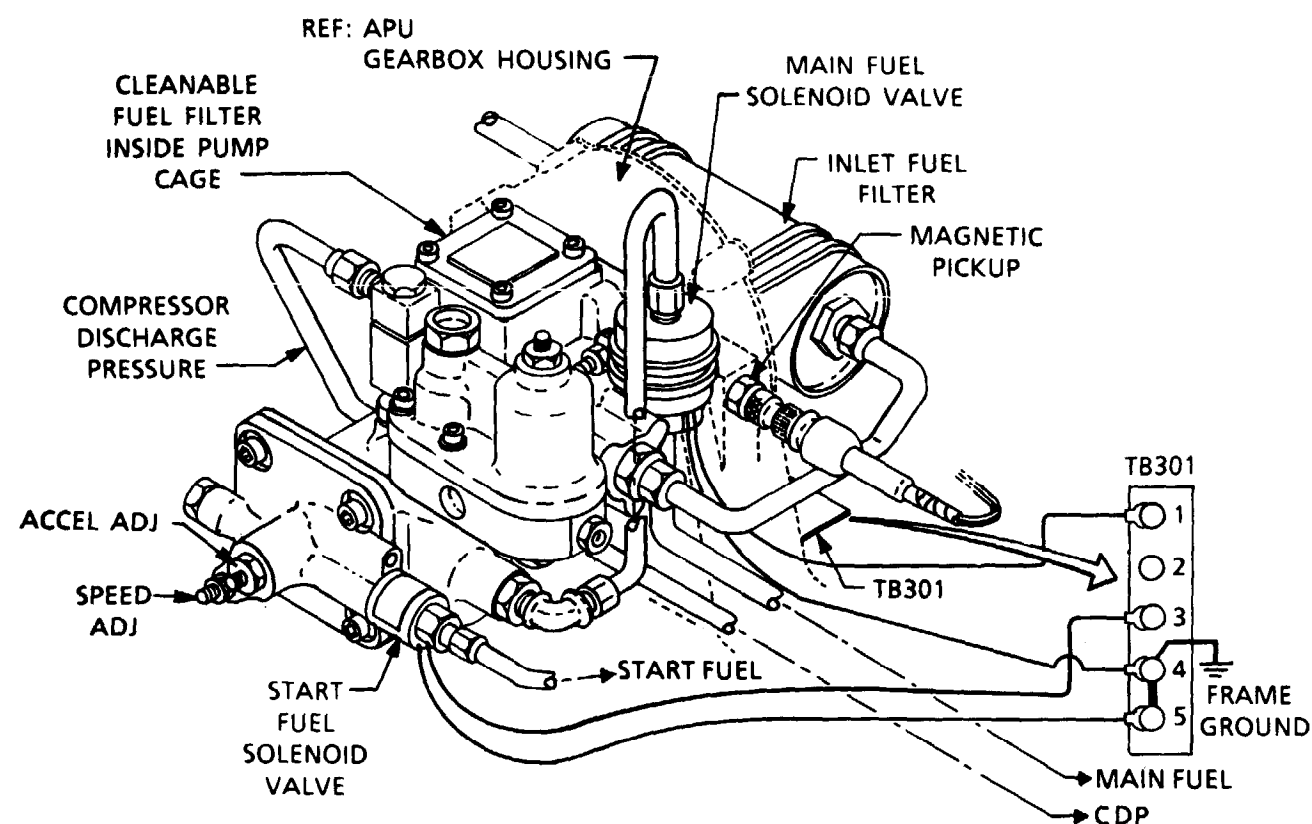

TABLE NO. 15-3.3 APU START AND MAIN FUEL VALVES ELECTRICAL TESTS

TEST CONDITIONS	COMPONENT	TEST POINTS	MULTIMETER READINGS	
			VOLTAGE	RESISTANCE
Connect Zolda Tester to ESU & APU. Refer to Para 15-6 for details. Move Master switch and Start / Run Switches to UP position.	Start Fuel Solenoid Valve	Terminal Board Terminals 3 & GND	28 Volts Between 5% & 70% APU Speed	---
		Terminal Board Terminals 5 & GND	0 Volts At all Times	---
	Main Fuel Solenoid Valve	Terminal Board Terminals 1 & GND	28 Volts Above 15% APU Speed	---
Move Start / Run Switch to DOWN position.	Terminal Board Ground Connection	Terminal 4 and GND	---	Zero Ohms
		Terminal 5 and GND	---	Zero Ohms
Remove ESU Plug 136P1	Start Fuel Solenoid Valve	Terminals 3 and 5	---	40 Ohms
	Main Fuel Solenoid Valve	Terminals 1 and 5	---	60 Ohms

NOTE: IGNITION EXCITER IS ALSO CONNECTED TO TERMINAL 3. RESISTANCE READING WOULD INCREASE WITH IGNITION EXCITER DISCONNECTED.

15-4 APU HYDRAULIC SYSTEM

PARAGRAPH 15-4
TABLE OF CONTENTS
APU HYDRAULIC SYSTEM TROUBLESHOOTING

PARAGRAPH	DESCRIPTION	FUNCTION	PAGE	PARAGRAPH	DESCRIPTION	FUNCTION	PAGE
15-4	APU HYDRAULIC SYSTEM		15-65	15-4.9	APU START ACCUMULATOR GAGE DOES NOT INDICATE AT LEAST 2850 PSI	TASK	15-78
15-4.1	APU HYDRAULIC SYSTEM COMPONENTS	DRAWING	15-68	15-4.10	APU DOES NOT MOTOR	TASK	15-80
15-4.2	OVERALL APU HYDRAULIC SYSTEM BLOCK DIAGRAM	DRAWING	15-69	15-4.11	APU MOTORS BUT DOES NOT START, ESU BITE INDICATES ○●●● OR ○○●● THEN ●○○● (HYDRAULIC FAULT)	TASK	15-82
15-4.3	MAJOR INTERCONNECTING APU HYDRAULIC SYSTEM SCHEMATIC	DRAWING	15-70	15-4.12	APU PUMP FAULT LIGHT IS ON	TASK	15-84
15-4.4	CHARGING ACCUMULATOR FLOW DIAGRAM	DRAWING	15-72	15-4.13	HYDRAULIC HANDPUMP SCHEMATIC	DRAWING	15-86
15-4.5	APU HYDRAULIC START MOTOR FLOW DIAGRAM	DRAWING	15-73				
15-4.6	APU HYDRAULIC PUMP FLOW DIAGRAM	DRAWING	15-74				
15-4.7	APU HYDRAULIC STARTING SYSTEM VISUAL CHECK	TASK	15-75				
15-4.8	APU HYDRAULIC STARTING SYSTEM OPERATIONAL CHECK	TASK	15-76				

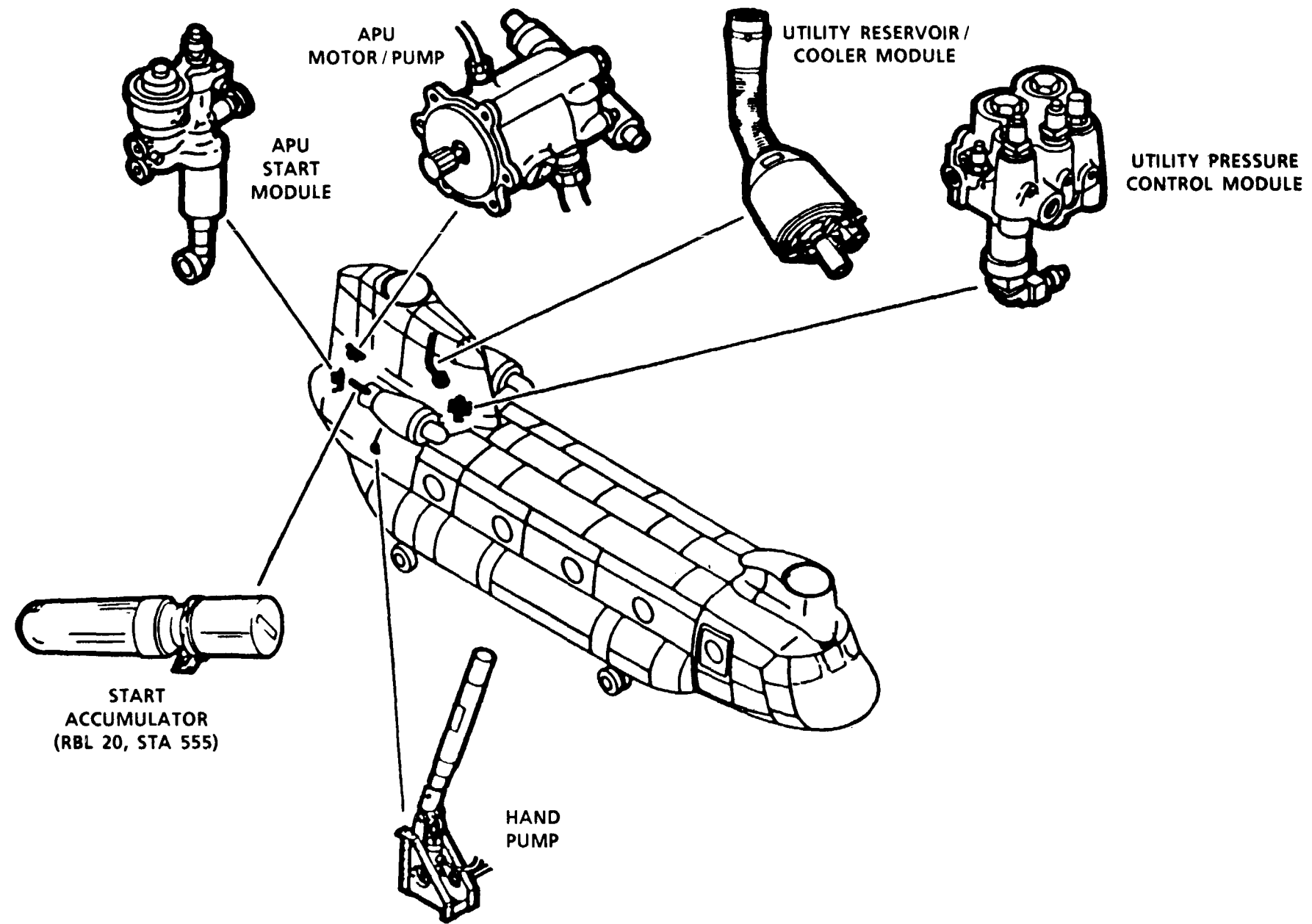

15-4.2 OVERALL APU HYDRAULIC SYSTEM BLOCK DIAGRAM

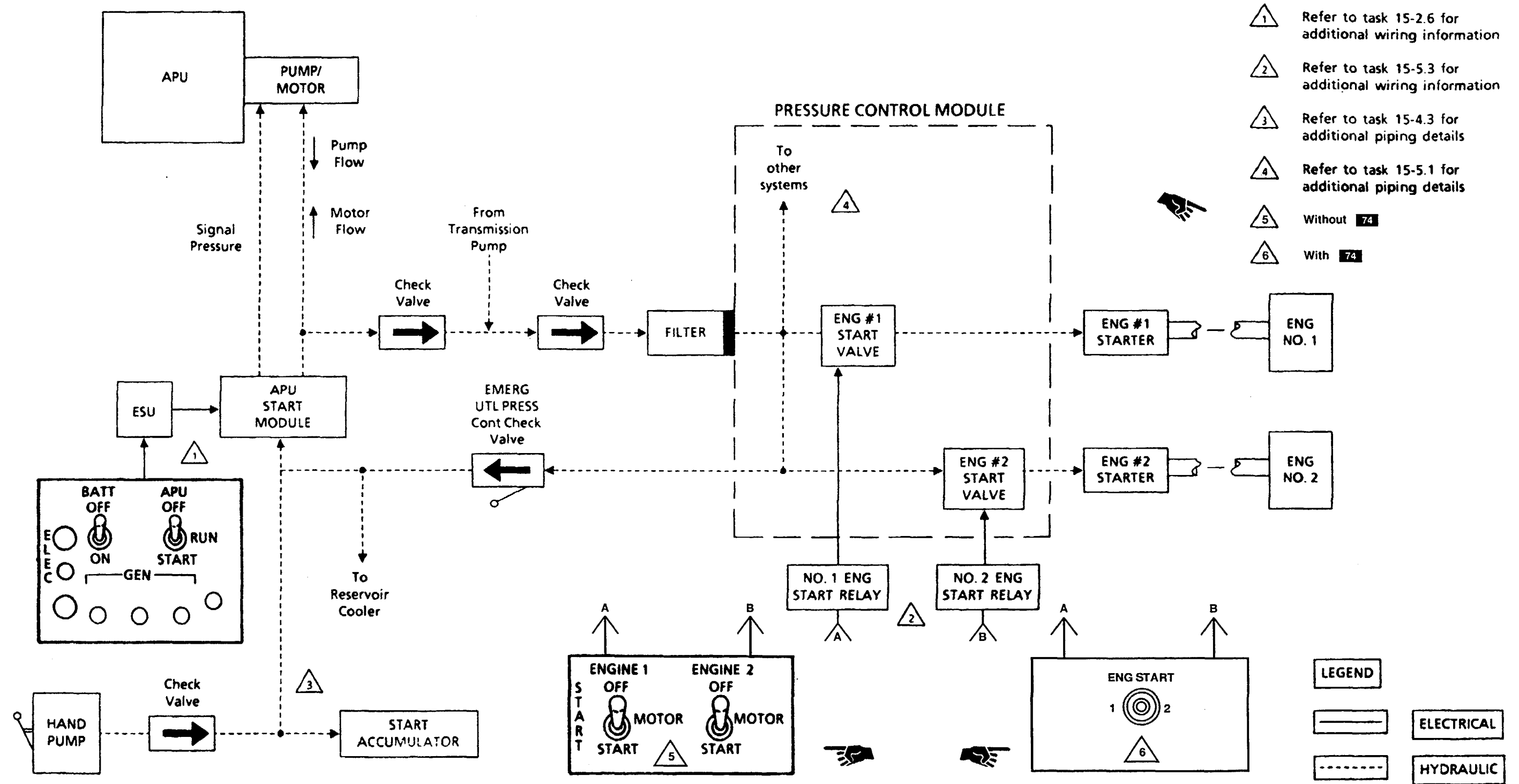

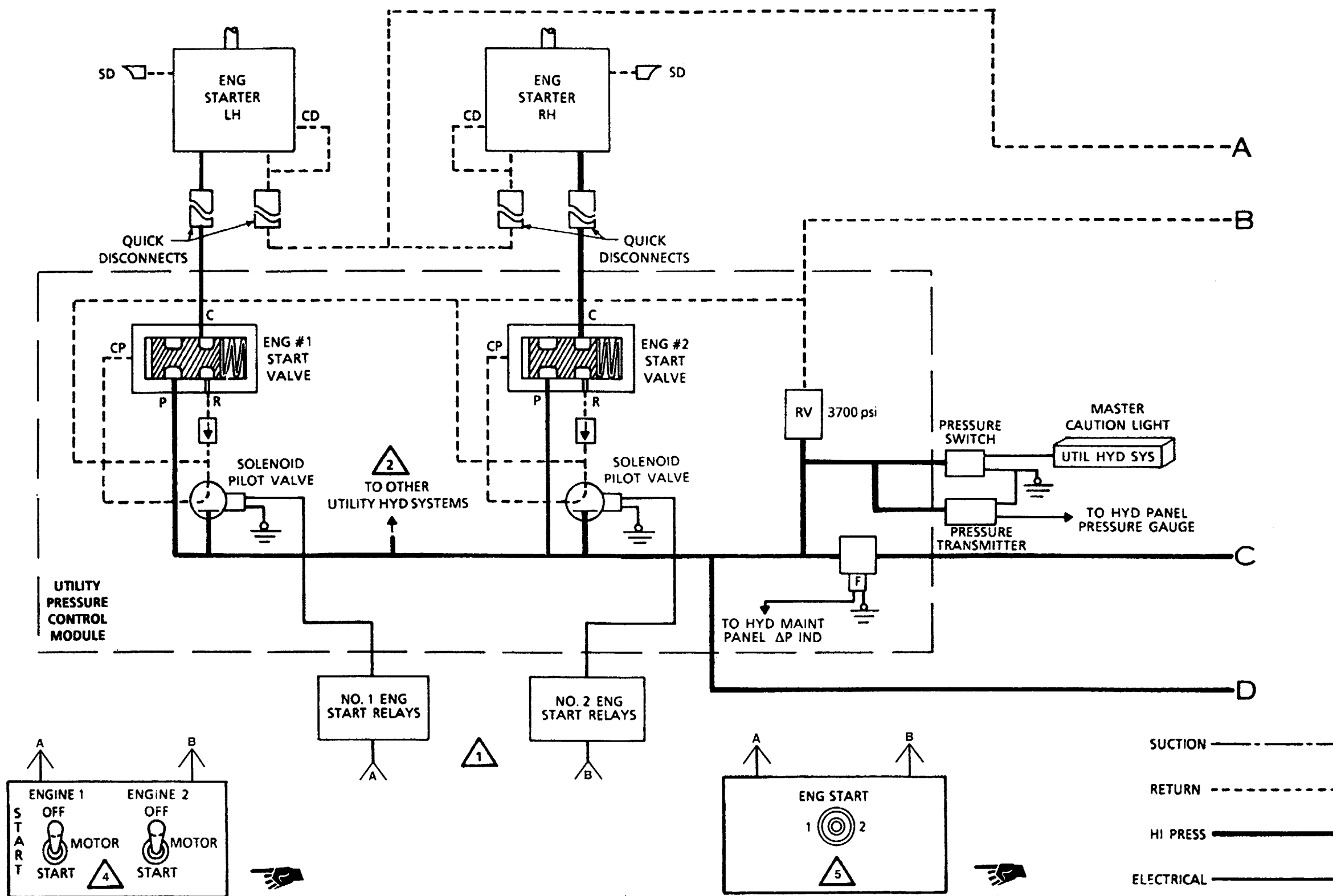

A72518

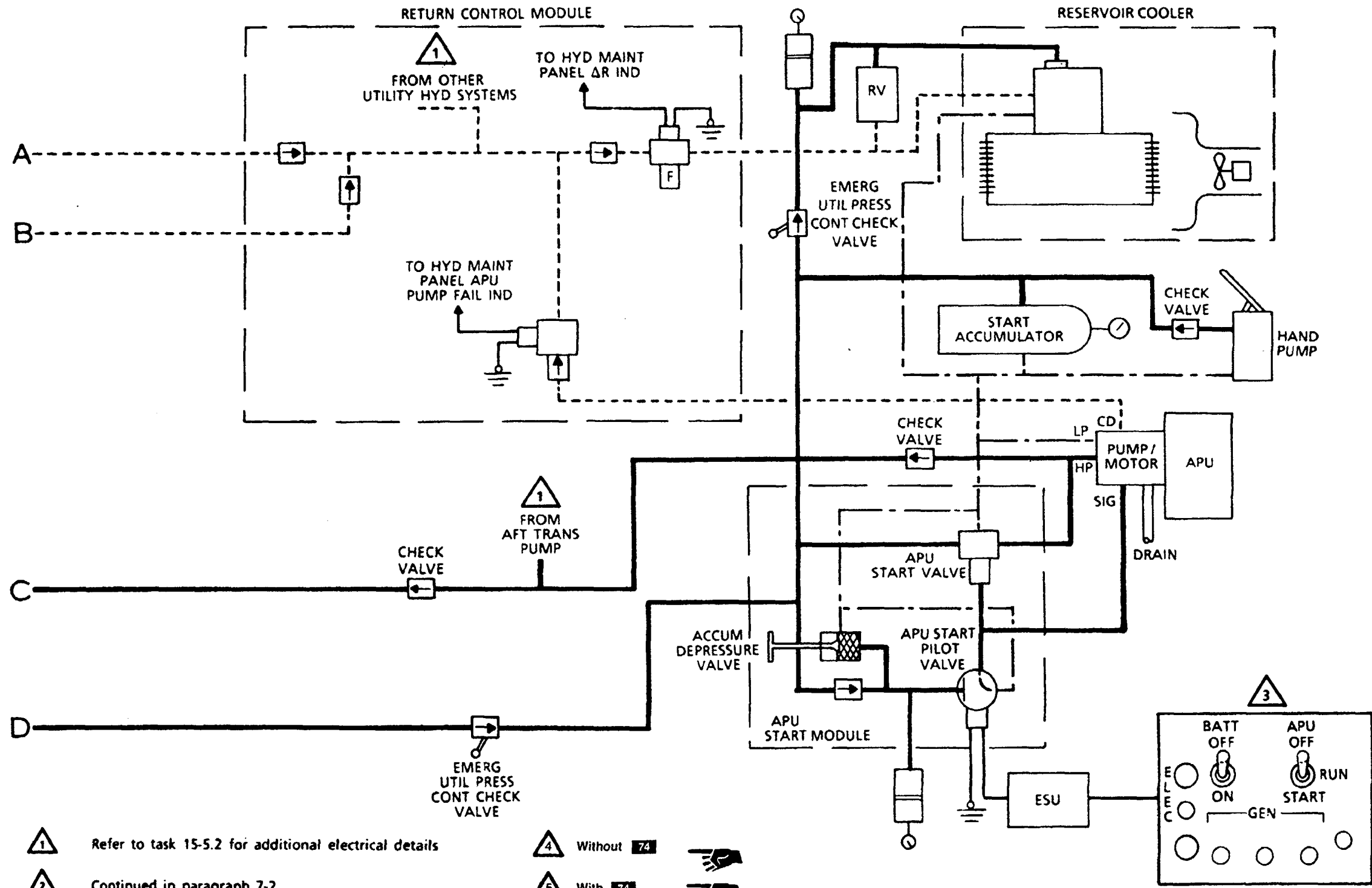

- Note:
- 1 Refer to task 15-5.2 for additional electrical details
 - 2 Continued in paragraph 7-2
 - 3 Refer to task 15-2.5 for additional electrical details
 - 4 Without 74
 - 5 With 74

A72519

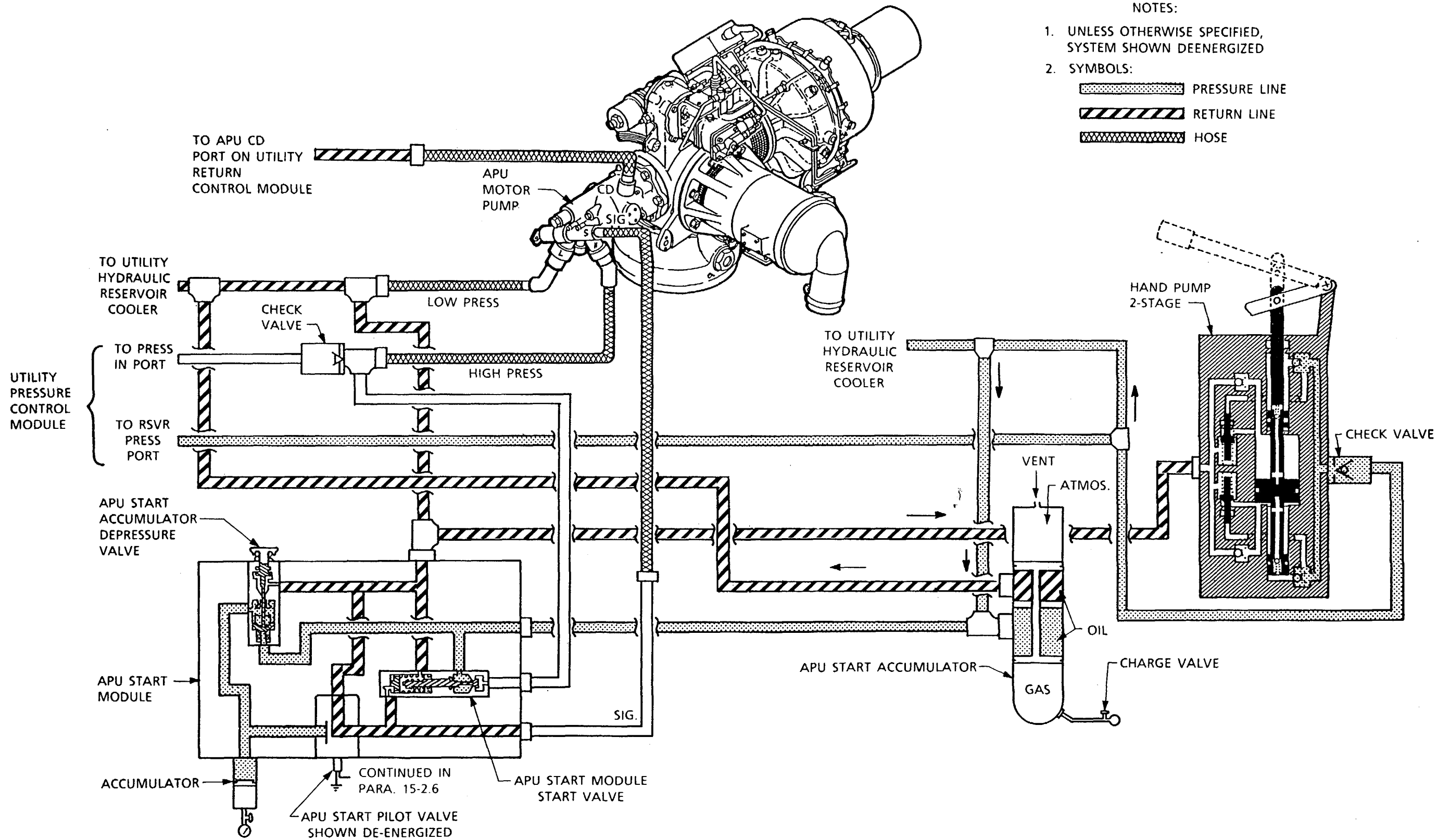

15-4.5 APU HYDRAULIC START MOTOR FLOW DIAGRAM

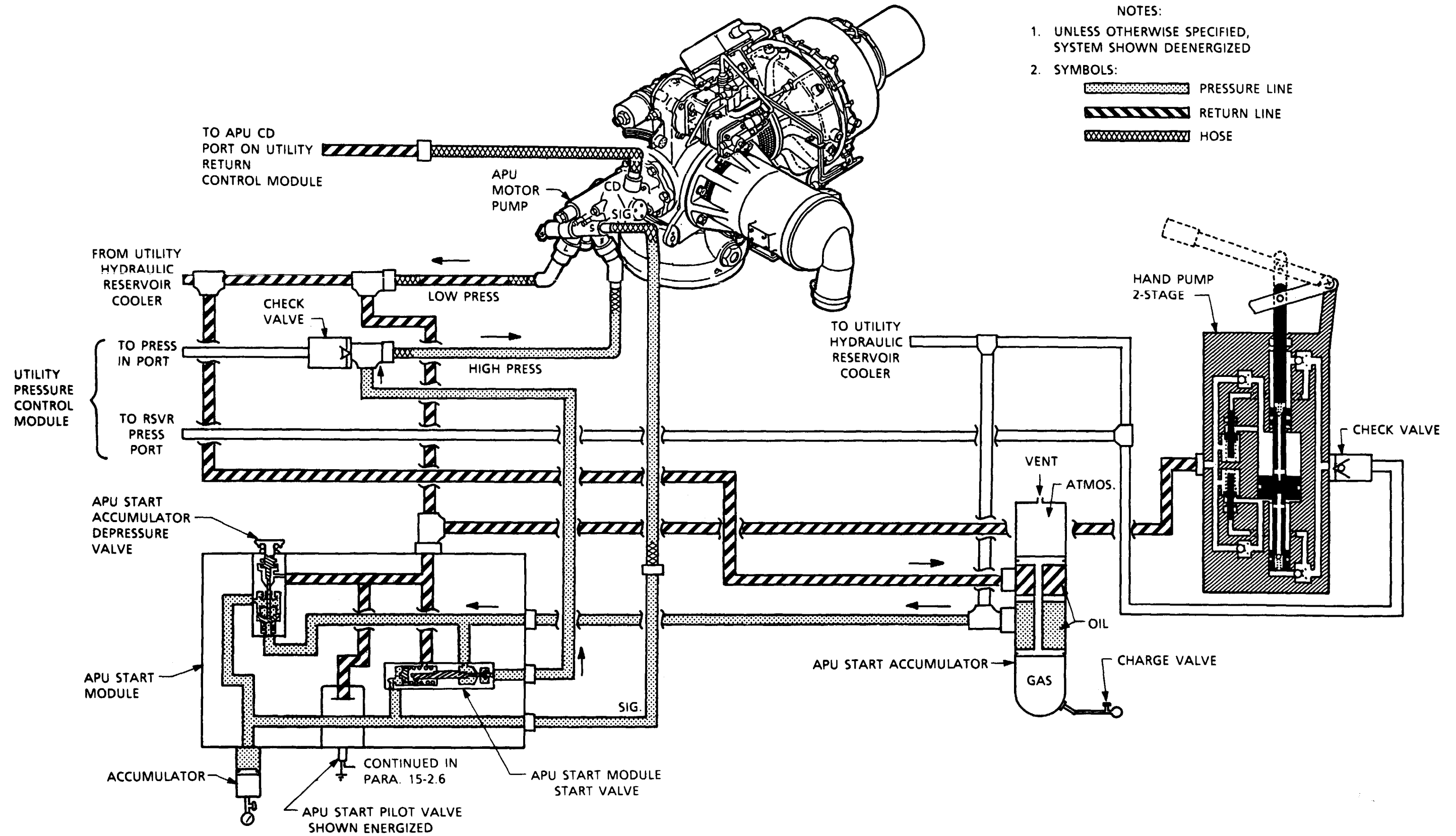

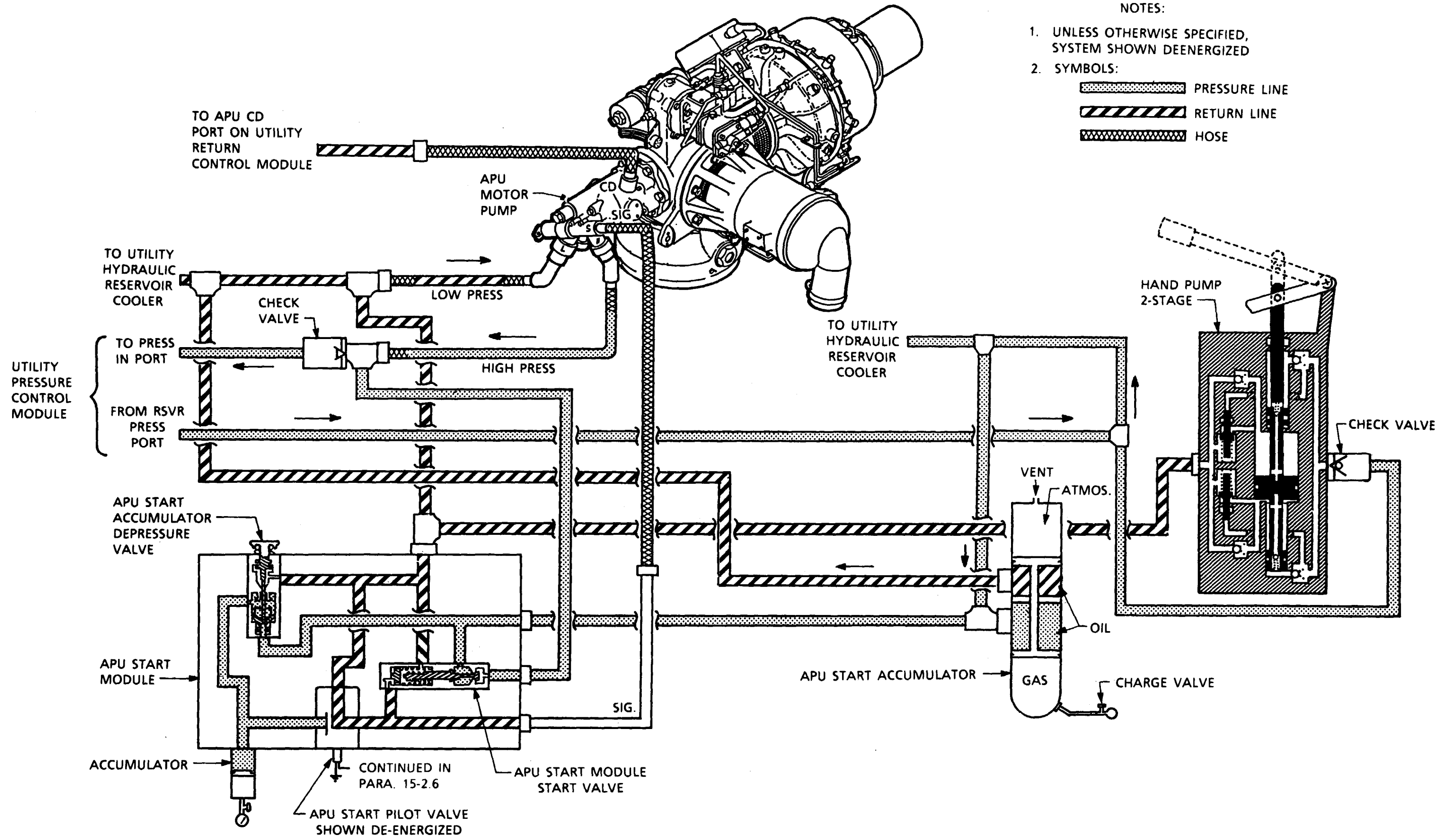

15-4.6 APU HYDRAULIC PUMP FLOW DIAGRAM



NOTES:

1. UNLESS OTHERWISE SPECIFIED, SYSTEM SHOWN DEENERGIZED
2. SYMBOLS:

-  PRESSURE LINE
-  RETURN LINE
-  HOSE

15-4.7 APU HYDRAULIC STARTING SYSTEM VISUAL CHECK

INITIAL SETUP

Applicable Configurations:
All

References:
TM 55-1520-240-23

Tools:
Aircraft Mechanic's Tool Kit,
NSN 5180-00-323-4692

Equipment Condition:
TM 55-1520-240-23:
Electrical Power Off
Battery Disconnected
Hydraulic Power Off
Right Aft Transmission
Baffle Open
Cargo Ramp Operational Level
(Task 7-3.4)

Materials:
None

Personnel Required:
Medium Helicopter Repairer

TASK	RESULT
1. Check APU start module accumulator (1).	If accumulator (1) or accumulator gage (2) is damaged, replace accumulator.
2. Check APU start module (3).	If any tube to module (3) is loose or damaged, tighten or replace it as required. If electrical connector to module is loose or damaged, tighten or replace it as required. If wiring to connector is damaged, repair or replace it as required.
3. Check APU start accumulator gage (4).	If gage (4) is loose or damaged, tighten or replace it as required.
4. Check APU start accumulator (5).	If accumulator (5) is loose or damaged, tighten or replace it as required. If any tube to accumulator is loose or damaged, tighten or replace it as required.
5. Check APU motor pump (6).	If pump (6) is loose or damaged, tighten or replace it as required. If any hose to pump is loose or damaged, tighten or replace it as required.

FOLLOW-ON MAINTENANCE:
None

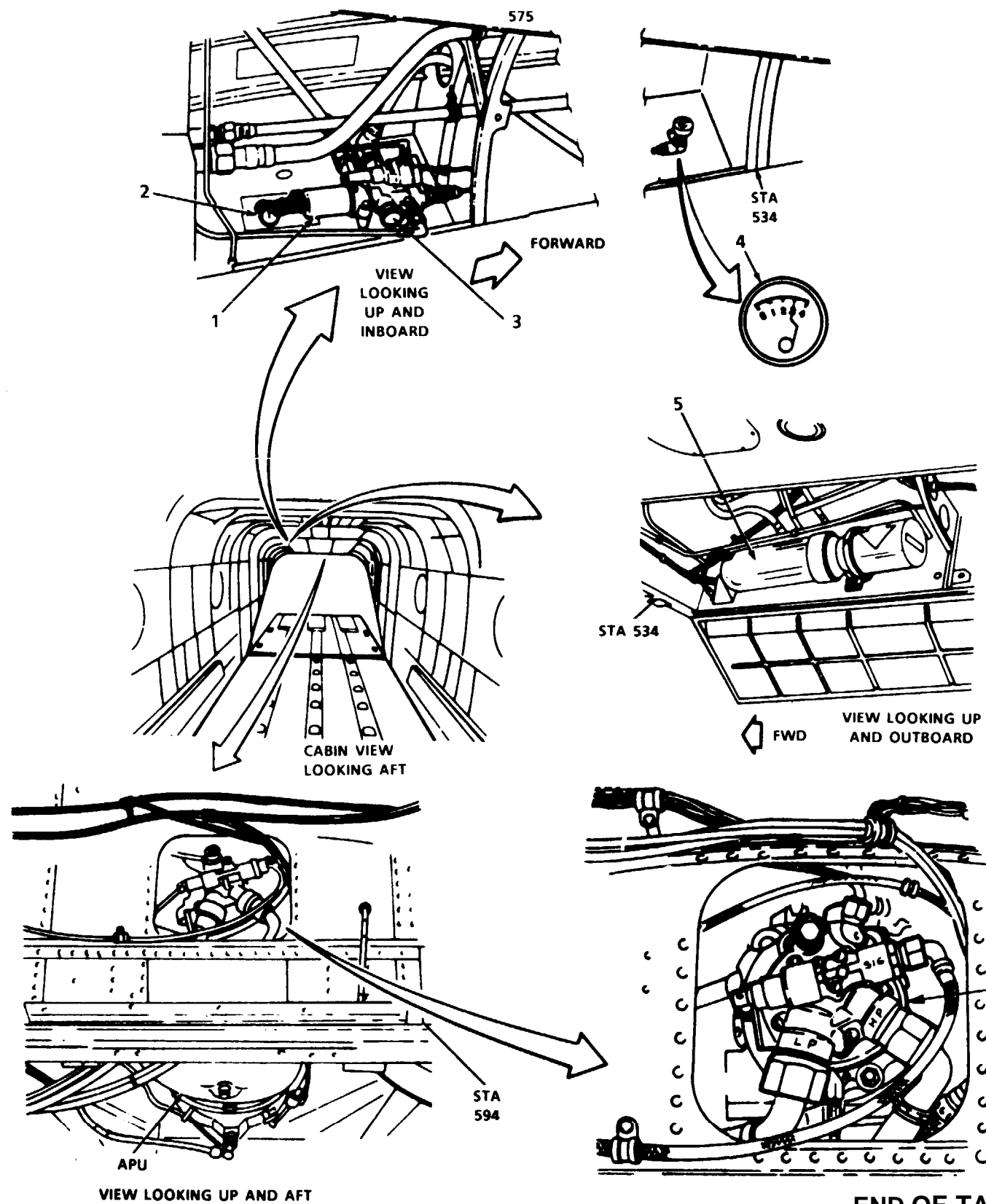

END OF TASK

**15-4.8 APU HYDRAULIC STARTING SYSTEM
OPERATIONAL CHECK**

INITIAL SETUP

Applicable Configurations:
All

References:
TM 55-1520-240-23

Tools:
None

Equipment Condition:
TM 55-1520-240-23:
Battery Connected
Electrical Power Off
Hydraulic Power Off
Visual Check of Apu Hydraulic
Starting System Performed (Task 15-4.7)

Materials:
None

Personnel Required:
Medium Helicopter Repairer (2)

TASK	RESULT
1. Check APU start accumulator gage (1).	Gage (1) shall indicate between 2850 and 3100 psi. If it does not, use hand pump to charge accumulator. If gage still does not indicate between 2850 and 3100 psi, go to task 15-4.9.
2. Start APU. Refer to task 15-1.5.	APU shall begin to motor and accelerate to running speed within <u>30 seconds</u> . UTILITY HYDRAULICS indicator (2) shall indicate <u>3200 to 3500 psi</u> . If indicator does not indicate <u>3200 to 3500 psi</u> , stop apu and go to task 7-2.4. If APU does not motor, go to task 15-4.10. If APU motors but does not start and ESU bite indicates ○ ○ ○ ● then ● ○ ○ ●, go to task 15-4.11.
3. Stop APU. Refer to task 15-1.5.	

FOLLOW-ON MAINTENANCE:
TM 55-1520-240-23

GO TO NEXT PAGE

15-4.8 APU HYDRAULIC STARTING SYSTEM
OPERATIONAL CHECK (CONTINUED)

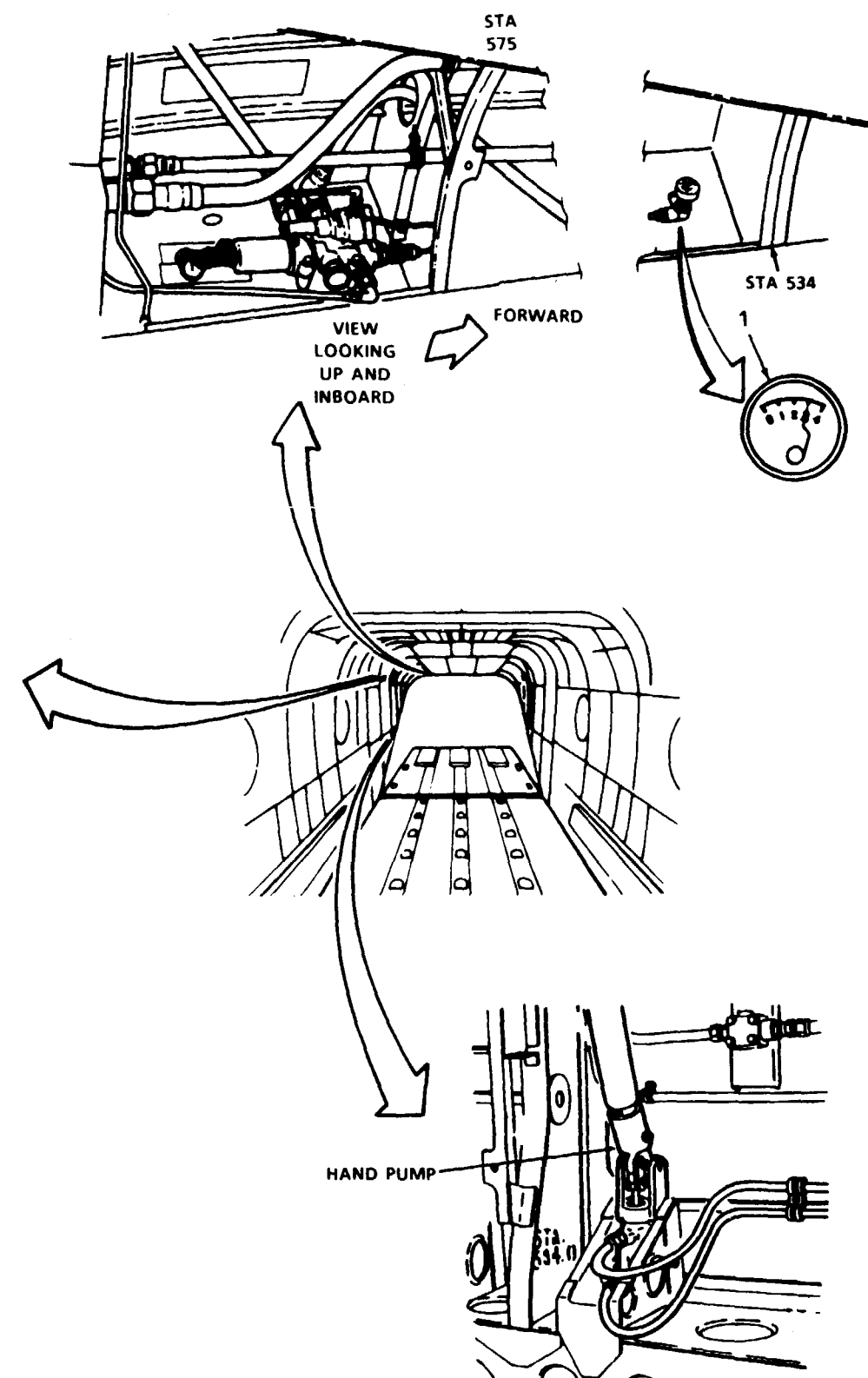
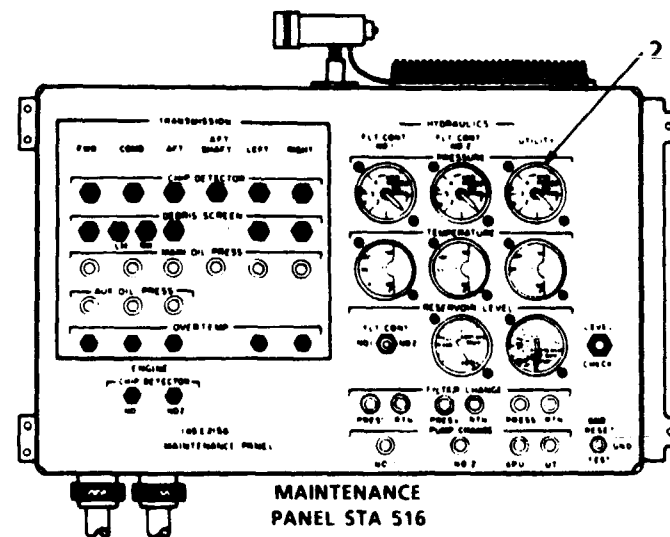
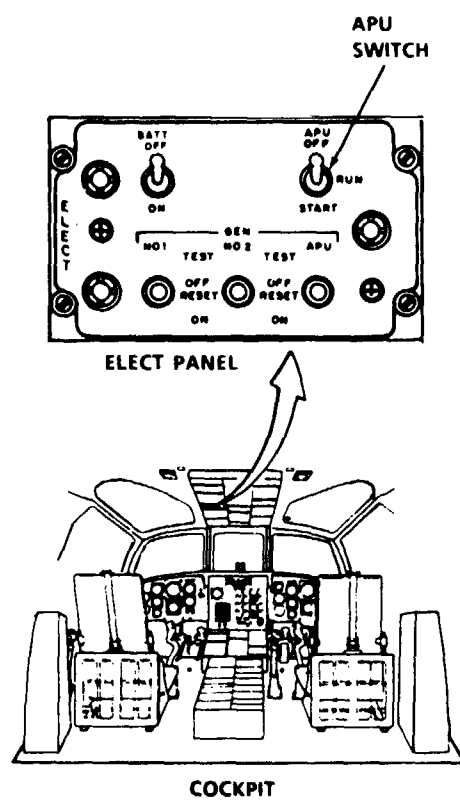

END OF TASK

15-4.9 APU START ACCUMULATOR GAGE DOES NOT INDICATE AT LEAST 2850 PSI

FAULT ISOLATION PROCEDURE

INITIAL SETUP

Applicable Configurations:
All

Took:
Aircraft Mechanic's Tool Kit,
NSN 5180-00-323-4692
Hydraulic Power Source
Pressure Gage 5000 PSI

Materials:
None

Personnel Required:
Medium Helicopter Repairer (2)

References:
TM 55-1520-240-23

Equipment Condition:
TM 55-1520-240-23:
Battery Connected
Electrical Power On
Hydraulic Power Off except as
needed

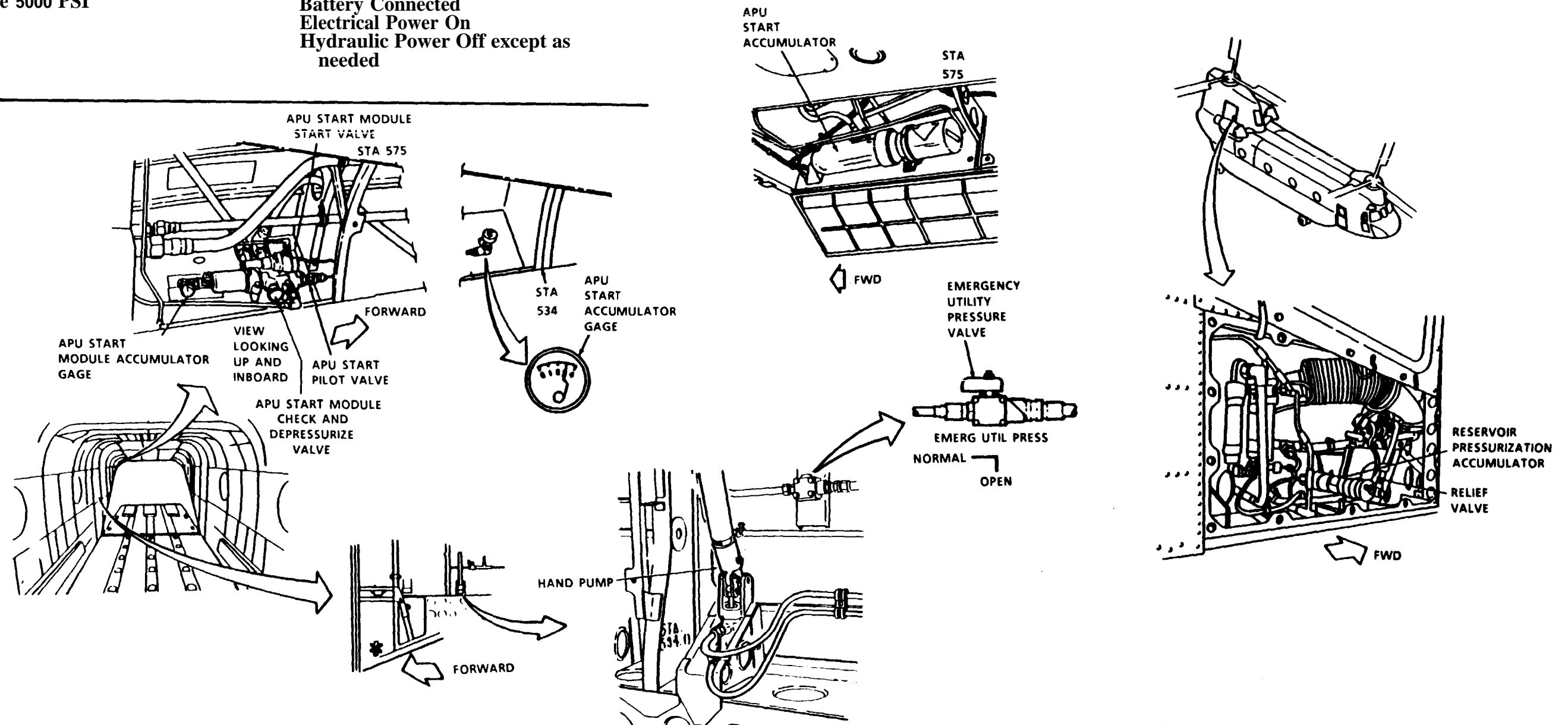

GO TO NEXT PAGE

15-4.9 APU START ACCUMULATOR GAGE DOES NOT INDICATE AT LEAST 2850 PSI (CONTINUED)

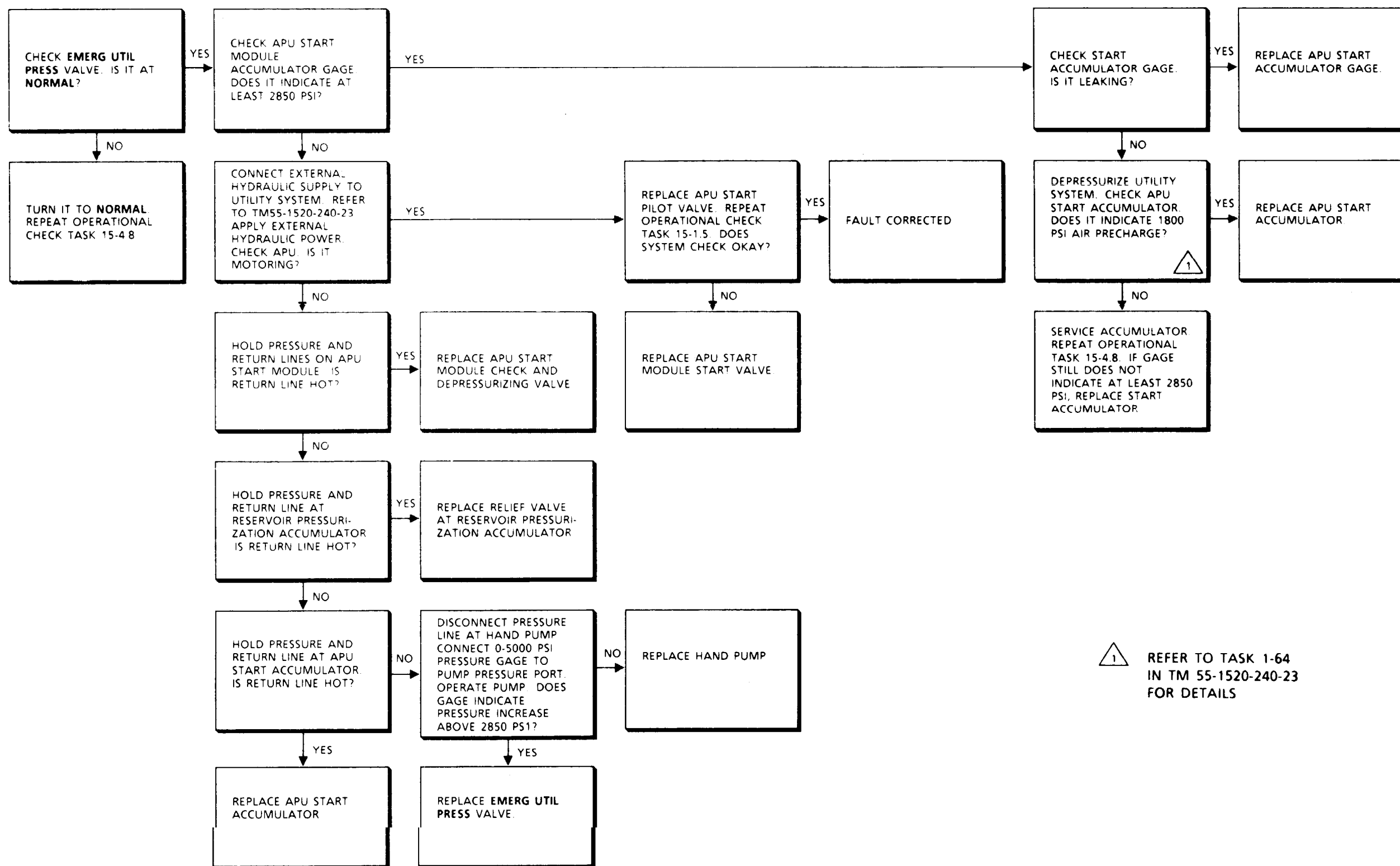

△ 1 REFER TO TASK 1-64 IN TM 55-1520-240-23 FOR DETAILS

END OF TASK

FAULT ISOLATION PROCEDURE

INITIAL SETUP

Applicable Configurations:
All

Tools:
Electrical Repairer's Tool Kit,
NSN 5180-00-323-4915
Multimeter
Hydraulic Power Source

Materials:
None

Personnel Required:
Aircraft Electrician
Medium Helicopter Repairer

References:
TM 55-1520-240-23
TM 55-1500-343-23

Equipment Condition:
TM 55-1520-240-23:
Battery Connected
Electrical Power On
Hydraulic Power Off

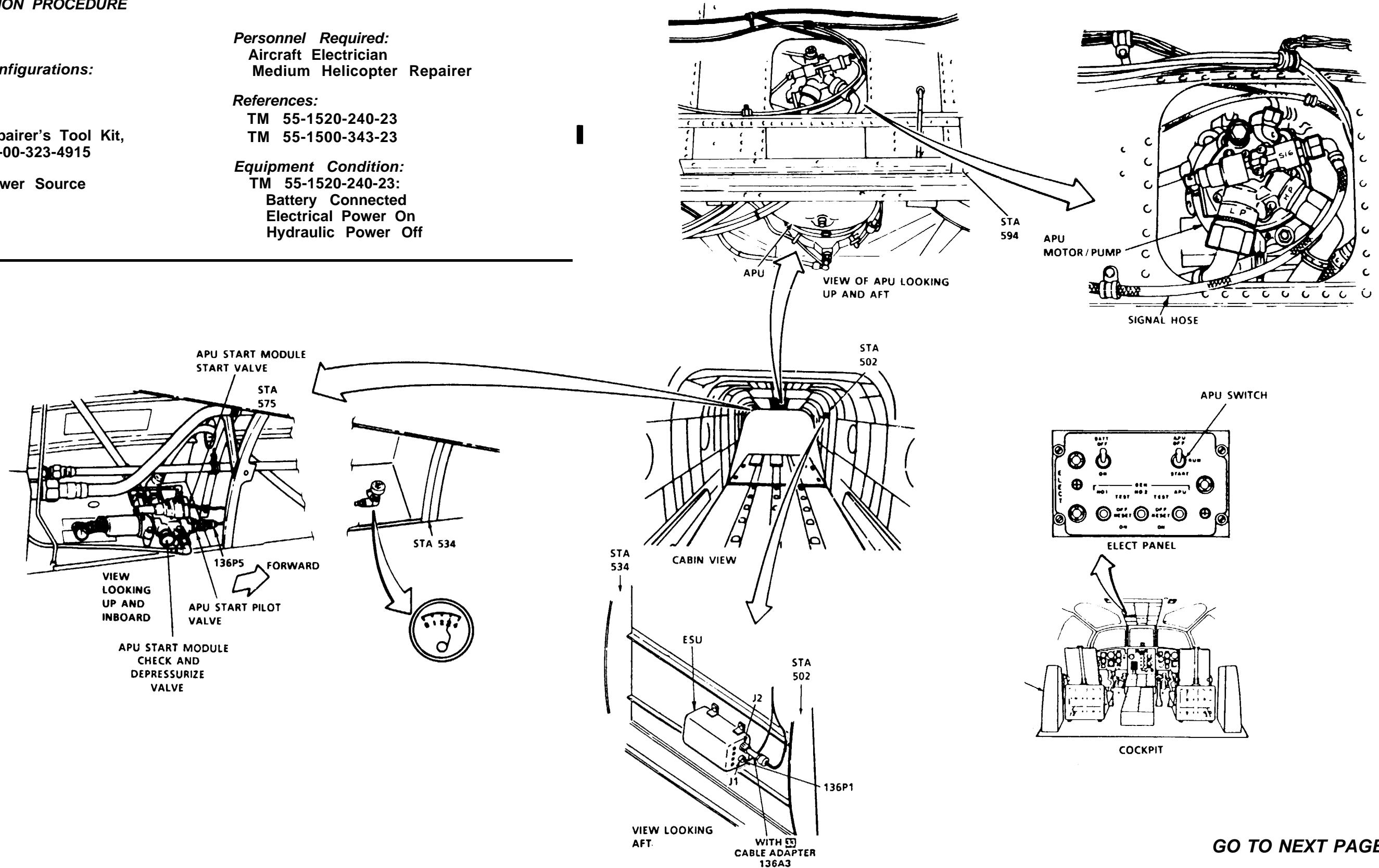

GO TO NEXT PAGE

15-4.10 APU DOES NOT MOTOR (CONTINUED)

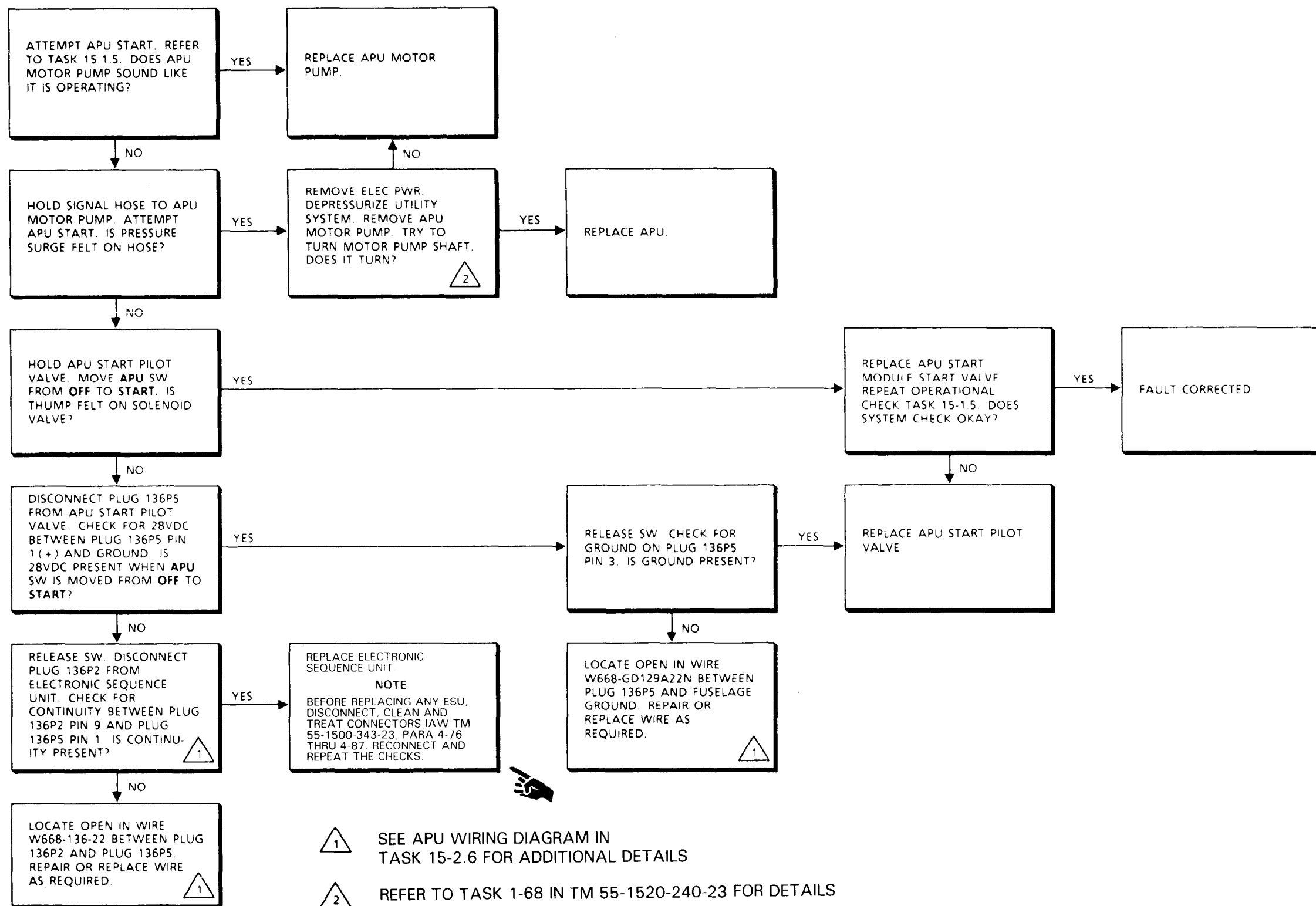

END OF TASK

15-4.11 APU MOTORS BUT DOES NOT START, ESU BITE INDICATES ○●●● OR ○○●● THEN ●○○● (HYDRAULIC FAULT)

FAULT ISOLATION PROCEDURE

INITIAL SETUP

Applicable Configurations:

All

Tools:

Aircraft Mechanic's Tool Kit,
NSN 6180-00-323-4692
Hydraulic Power Source

Materials:

None

Personnel Required:

Medium Helicopter Repairer (2)

References:

TM 55-1520-240-23

Equipment Condition:

TM 55-1520-240-23:
Battery Connected
Electrical Power On
Hydraulic Power Off

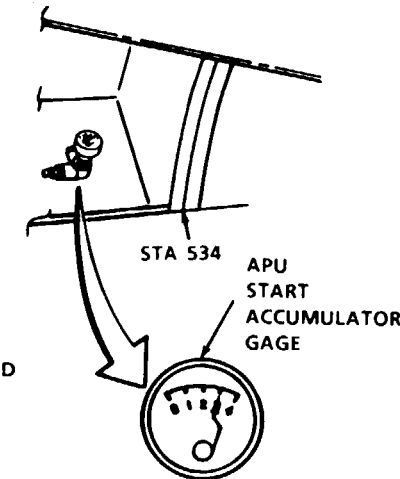
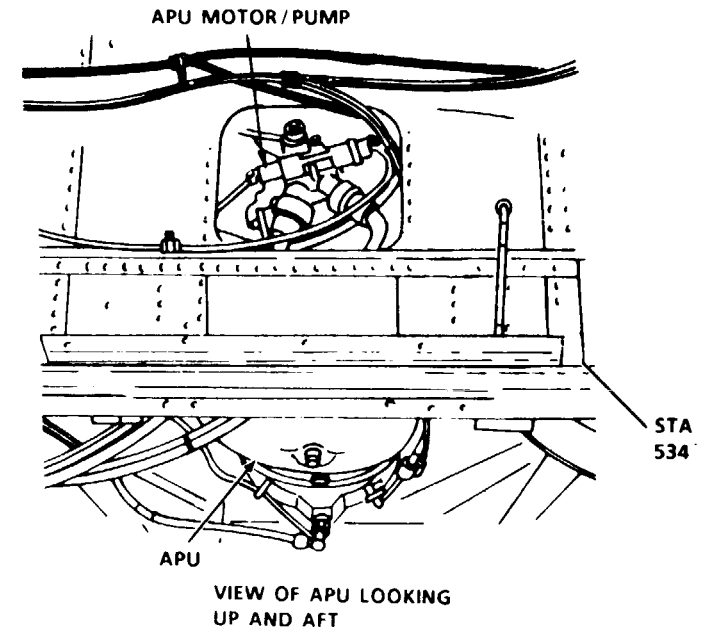
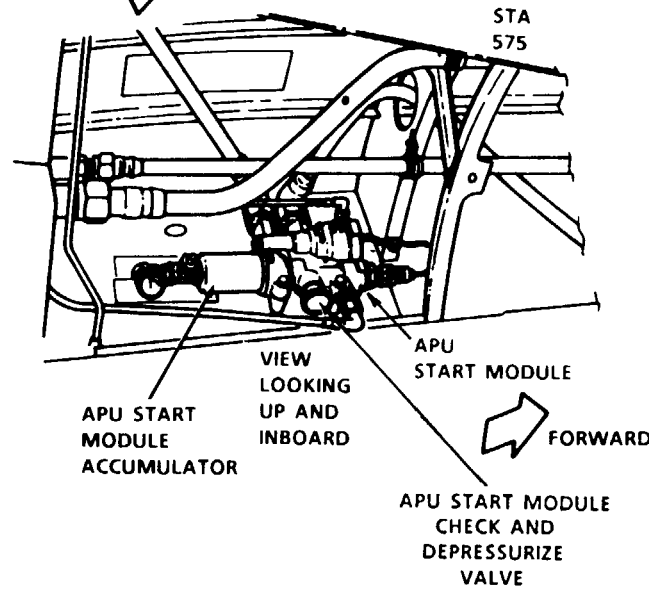
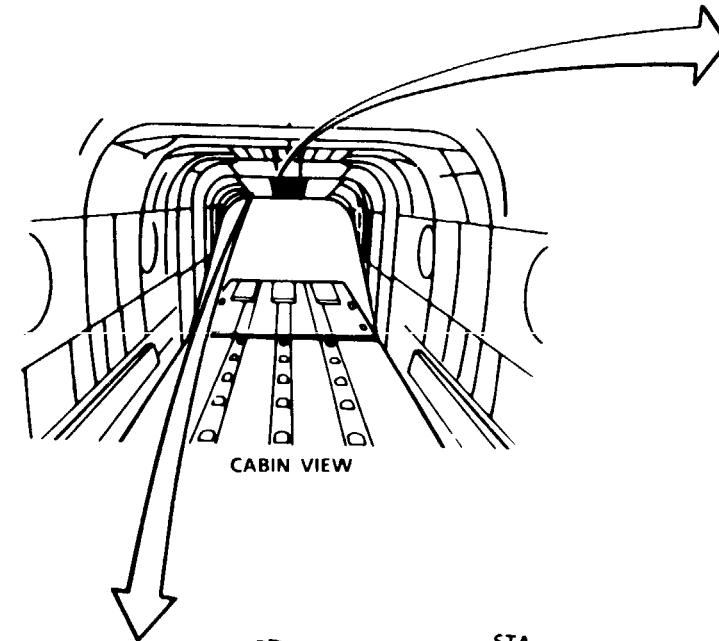
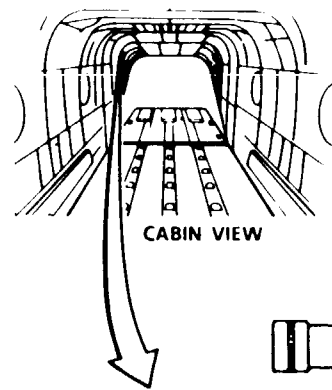
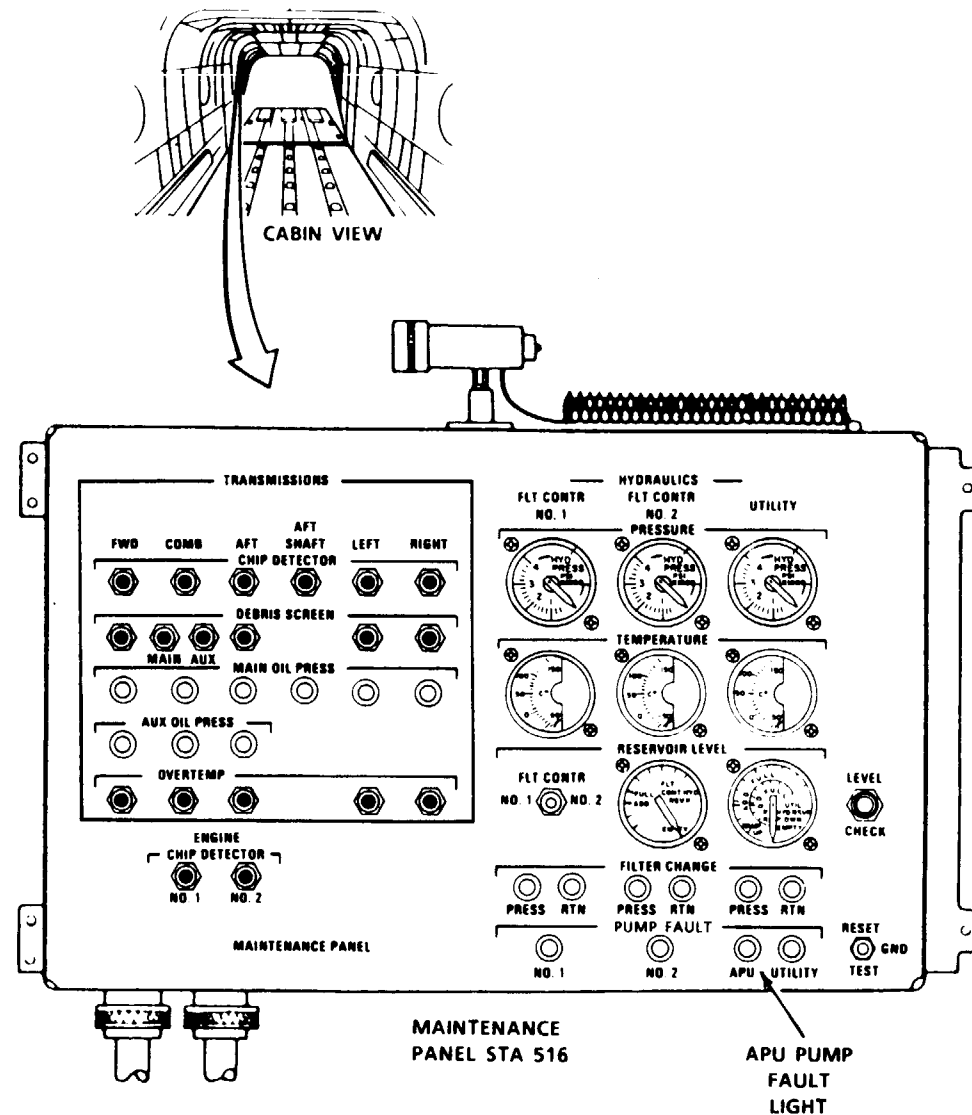

15-4.11 APU MOTORS BUT DOES NOT START, ESU BITE INDICATES ○ ● ● ● OR ○ ○ ● ● THEN ● ○ ○ (HYDRAULIC FAULT) (CONTINUED)

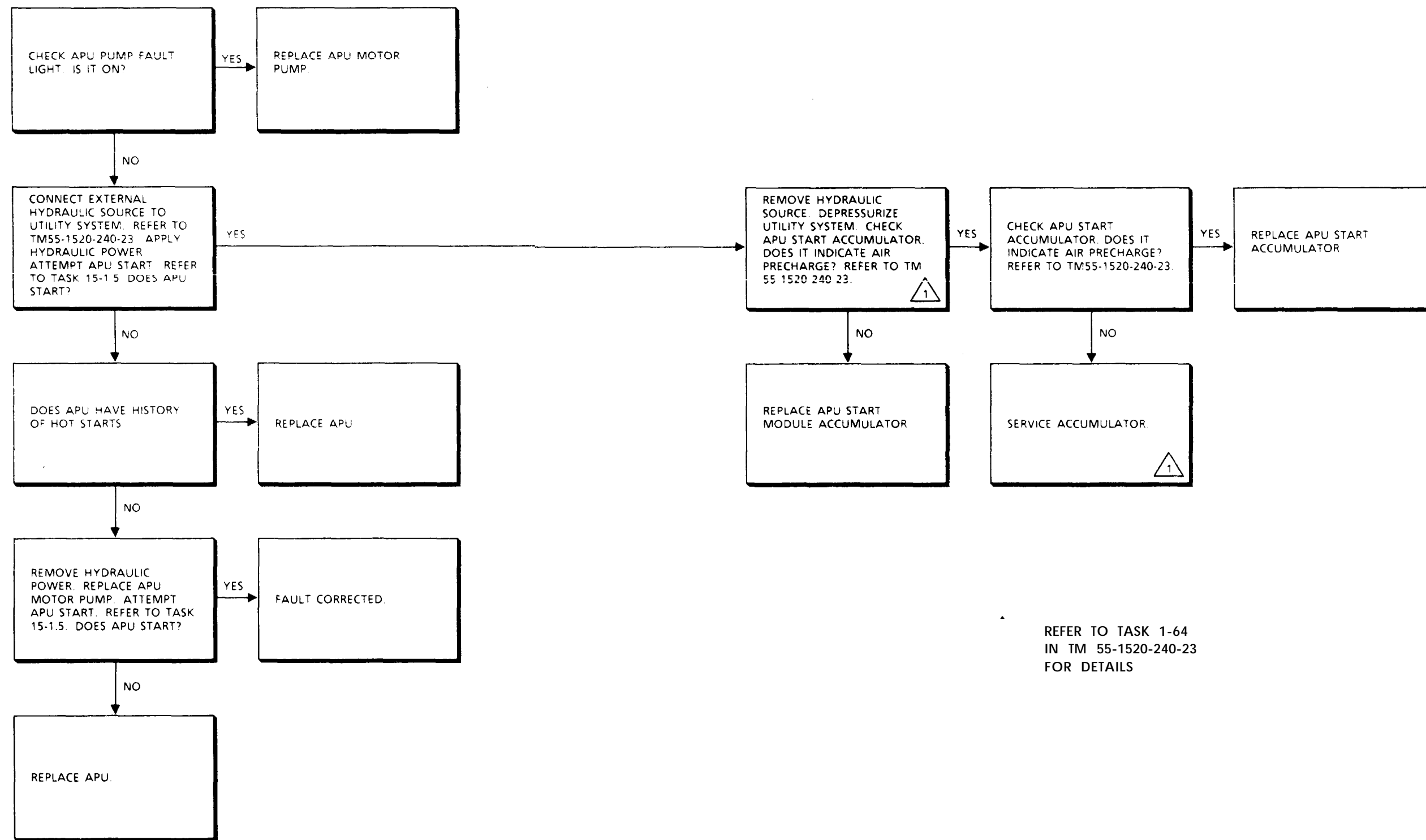

REFER TO TASK 1-64 IN TM 55-1520-240-23 FOR DETAILS

15-4.12 APU PUMP FAULT LIGHT IS ON

FAULT ISOLATION PROCEDURE

INITIAL SETUP

Applicable Configurations:
All

Tools:
Electrical Repairer's Tool Kit,
NSN 5180-00-323-4915
Aircraft Mechanic's Tool Kit,
NSN 5180-00-323-4692
Multimeter

Materials:
None

Personnel Required:
Medium Helicopter Repairer
Aircraft Electrician

References:
TM 55-1520-280-23

Equipment Condition:
TM 55-1520-240-23:
Battery Connected
Electrical Power On
Hydraulic Power On

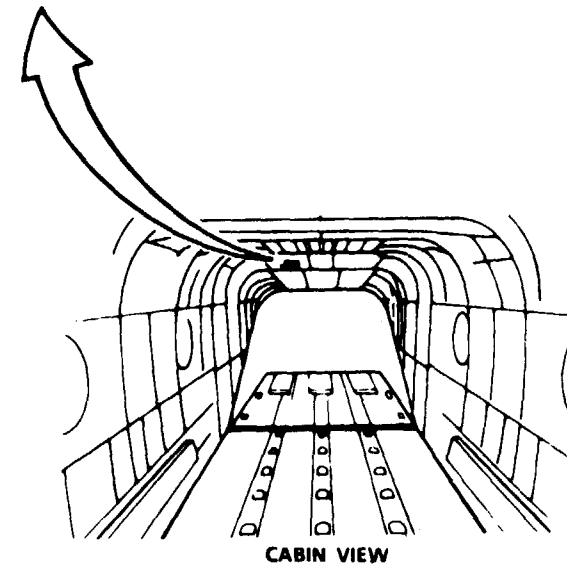
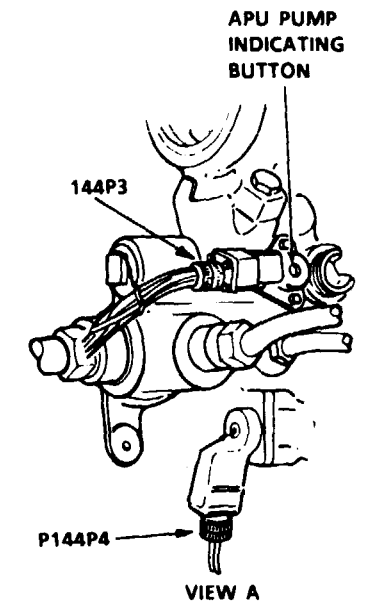
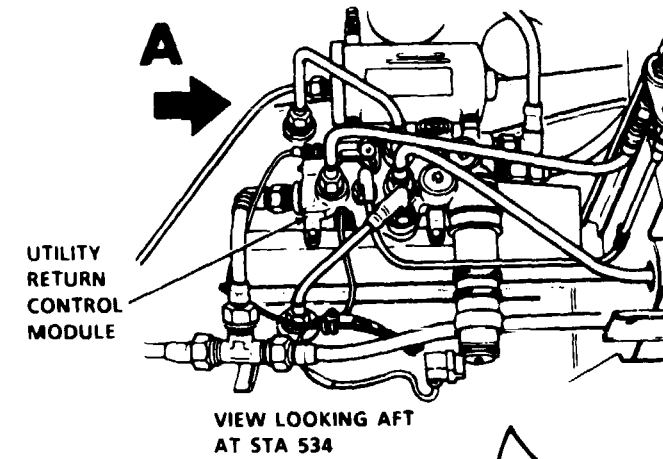
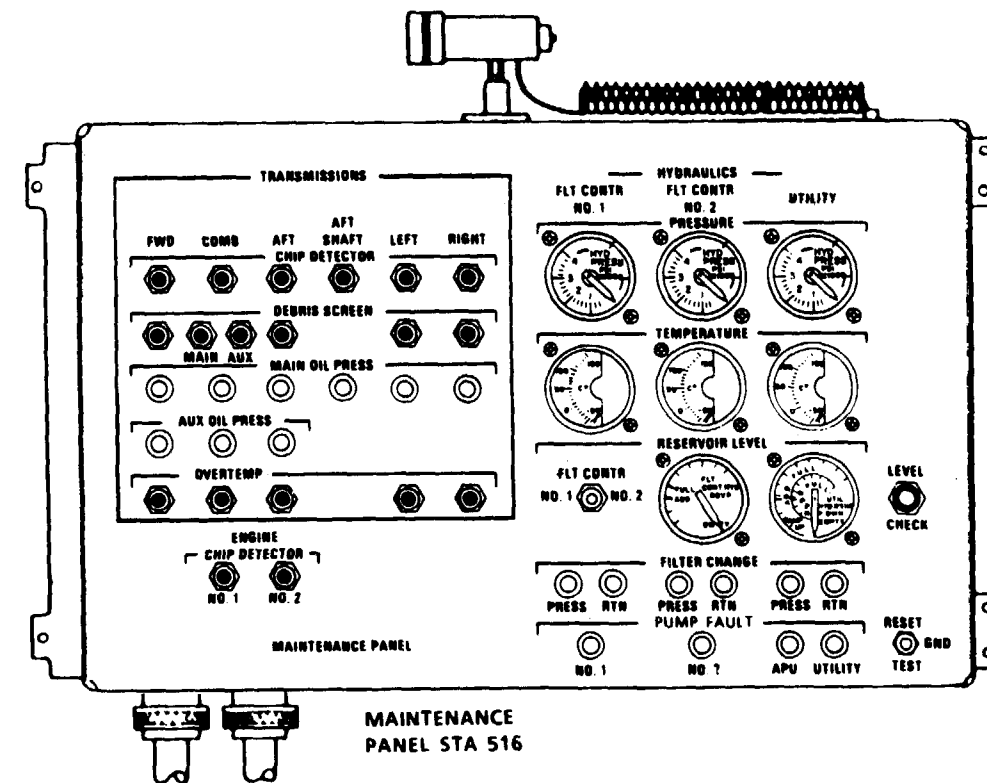
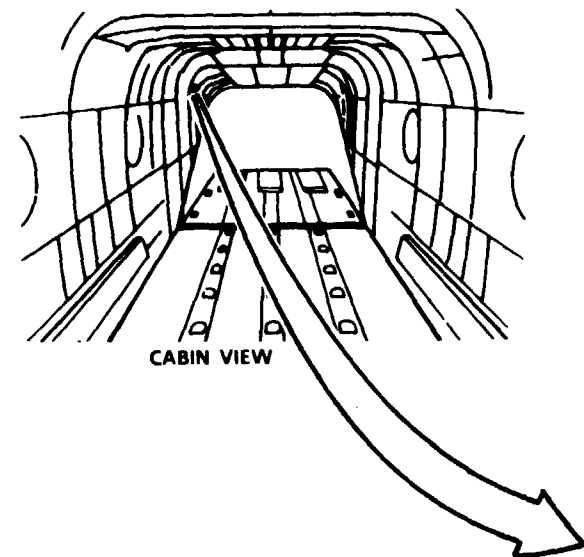

GO TO NEXT PAGE

15-4.12 APU PUMP FAULT LIGHT IS ON (CONTINUED)

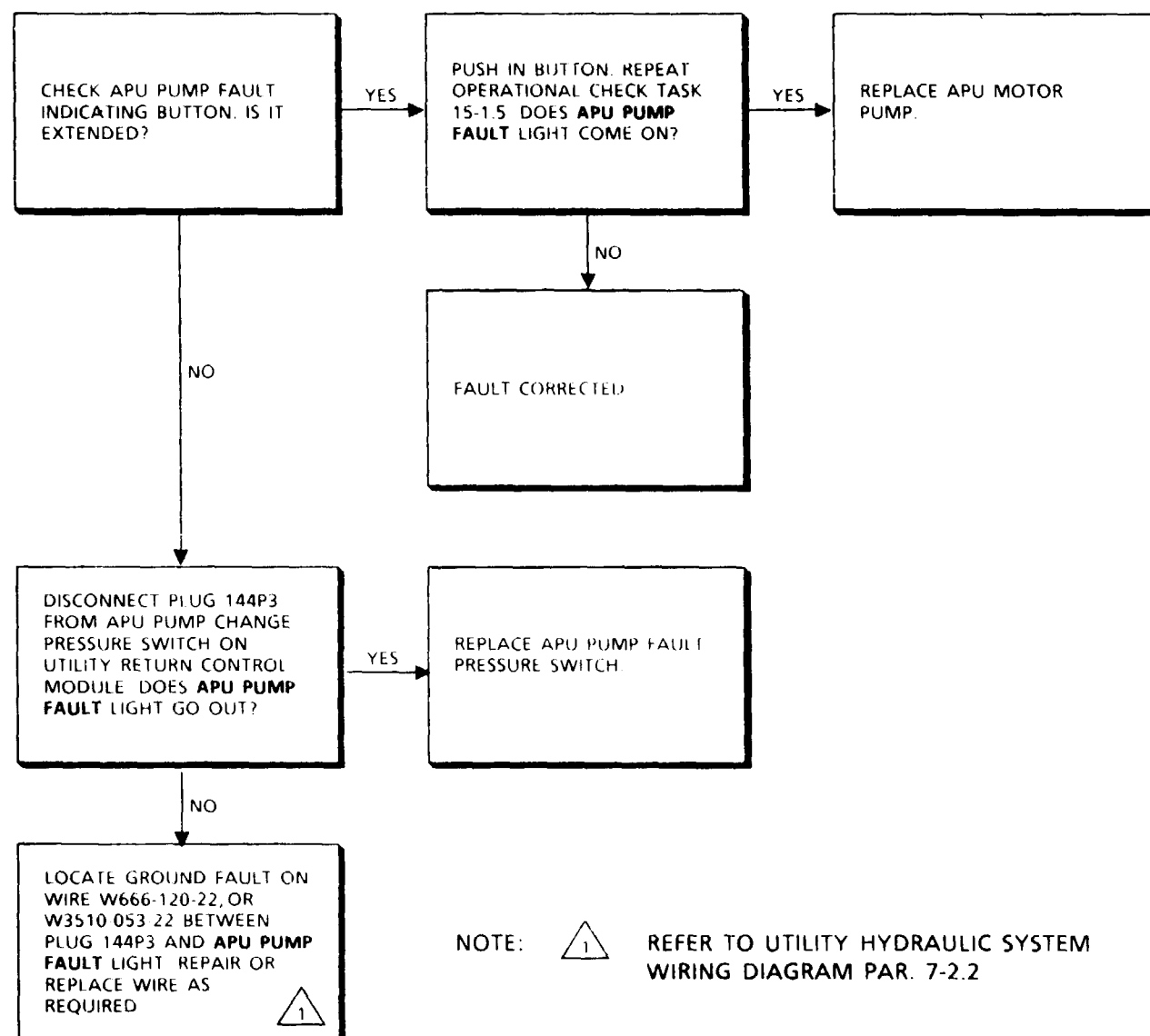

END OF TASK

15-5 APU / ENGINE HYDRAULIC STARTER SYSTEM

PARAGRAPH 15-5

TABLE OF CONTENTS

APU/ENGINE HYDRAULIC STARTER SYSTEM TROUBLESHOOTING

PARAGRAPH	DESCRIPTION	FUNCTION	PAGE
15-5	ENGINE HYDRAULIC STARTING SYSTEM		15-87
15-5.1	ENGINE HYDRAULIC STARTING SYSTEM SCHEMATIC	DRAWING	15-90
15-5.2	ENGINE START SYSTEM ELECTRICAL SCHEMATIC (HYDRAULIC PORTION)	DRAWING	15-91
15-5.3	ENGINE START SYSTEM WIRING DIAGRAM (HYDRAULIC PORTION)	TASK	15-92
15-5.4	ENGINE HYDRAULIC STARTING SYSTEM VISUAL CHECK	TASK	15-95
15-5.5	ENGINE HYDRAULIC STARTING SYSTEM OPERATIONAL CHECK (WITHOUT 74)	TASK	15-96
15-5.5.1	ENGINE HYDRAULIC STARTING SYSTEM OPERATIONAL CHECK (WITH 74)	TASK	15-96.2
15-5.6	NO. 1 OR NO. 2 ENGINE DOES NOT MOTOR (HYDRAULIC SYSTEM) (WITHOUT 74)	TASK	15-98
15-5.6.1	NO. 1 OR NO. 2 ENGINE DOES NOT MOTOR (HYDRAULIC SYSTEM) (WITH 74)	TASK	15-98.2
15-5.7	NO. 1 OR NO. 2 ENGINE KEEPS MOTORING WHEN ENGINE START SWITCH SET TO OFF	TASK	15-100

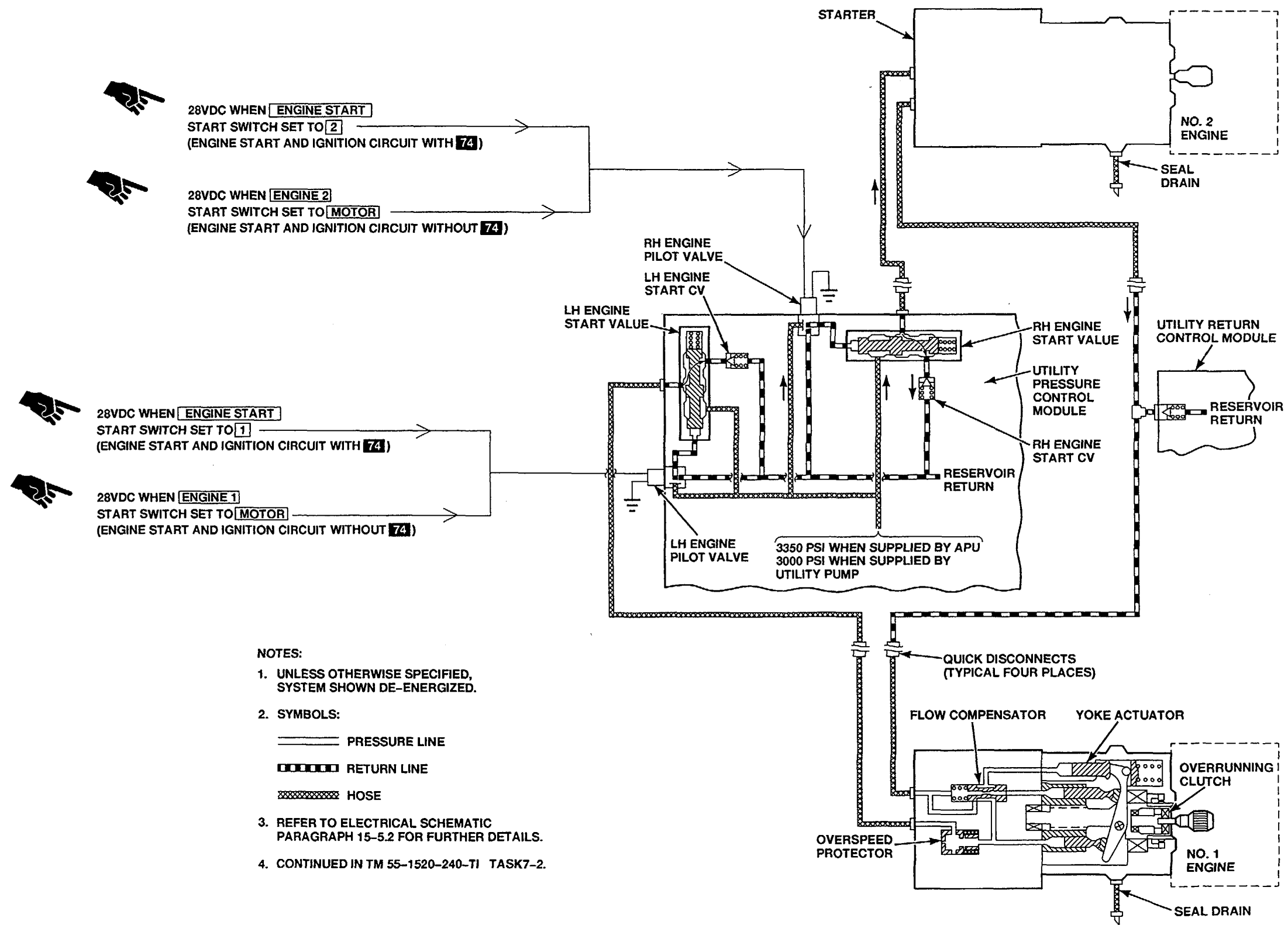

A72520

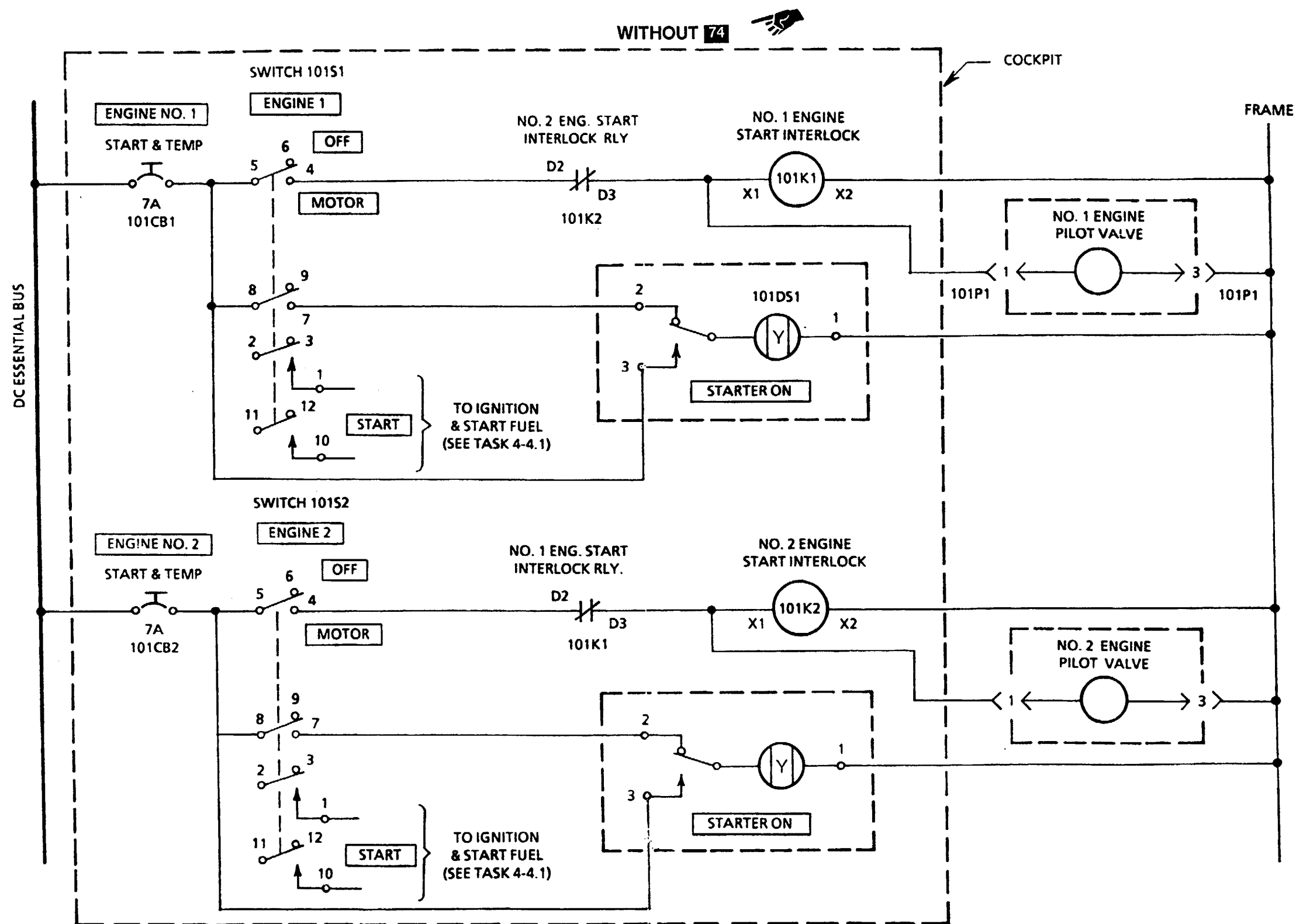

A72529

WITH 74

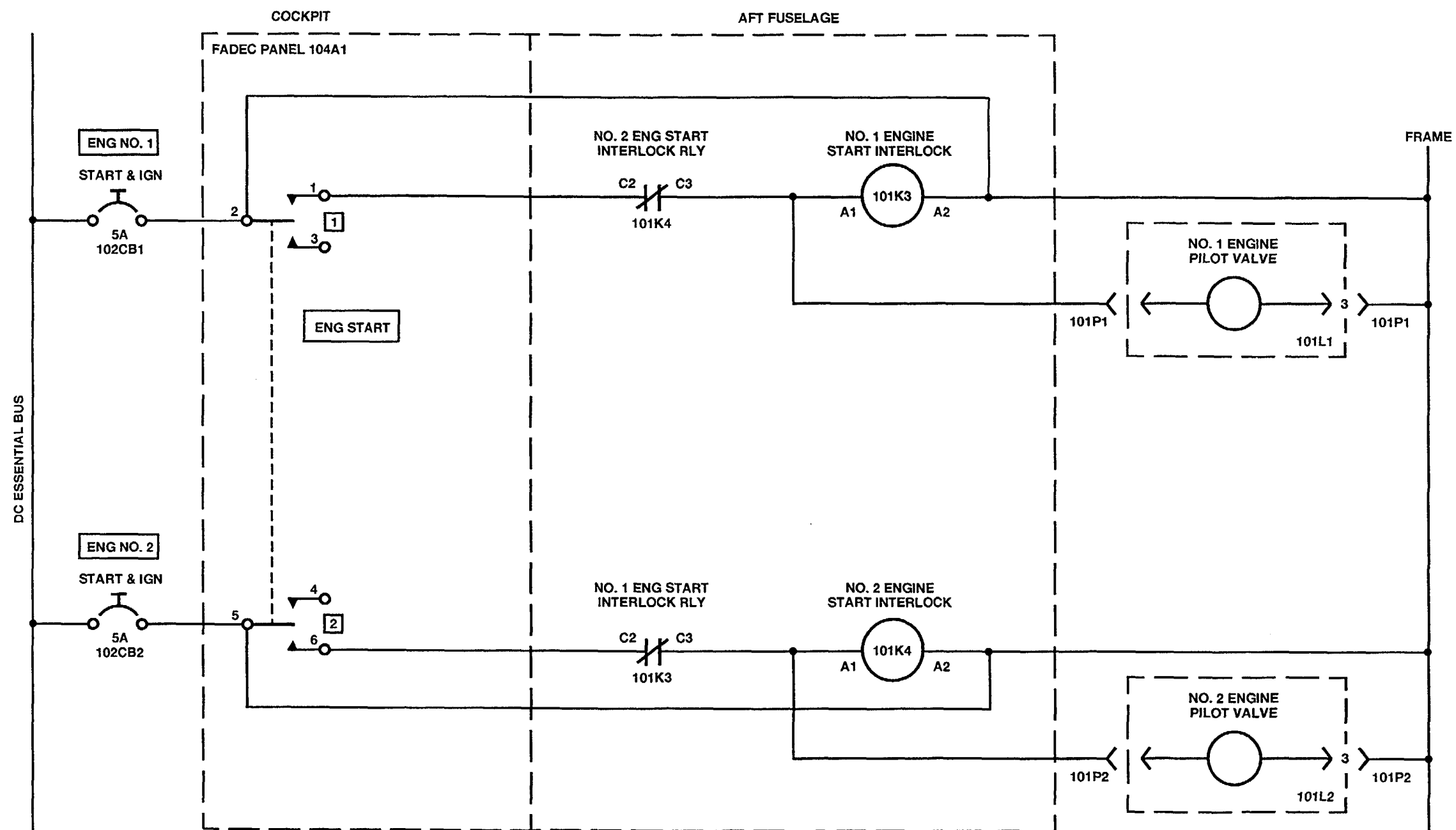

A72521

WITHOUT 74 

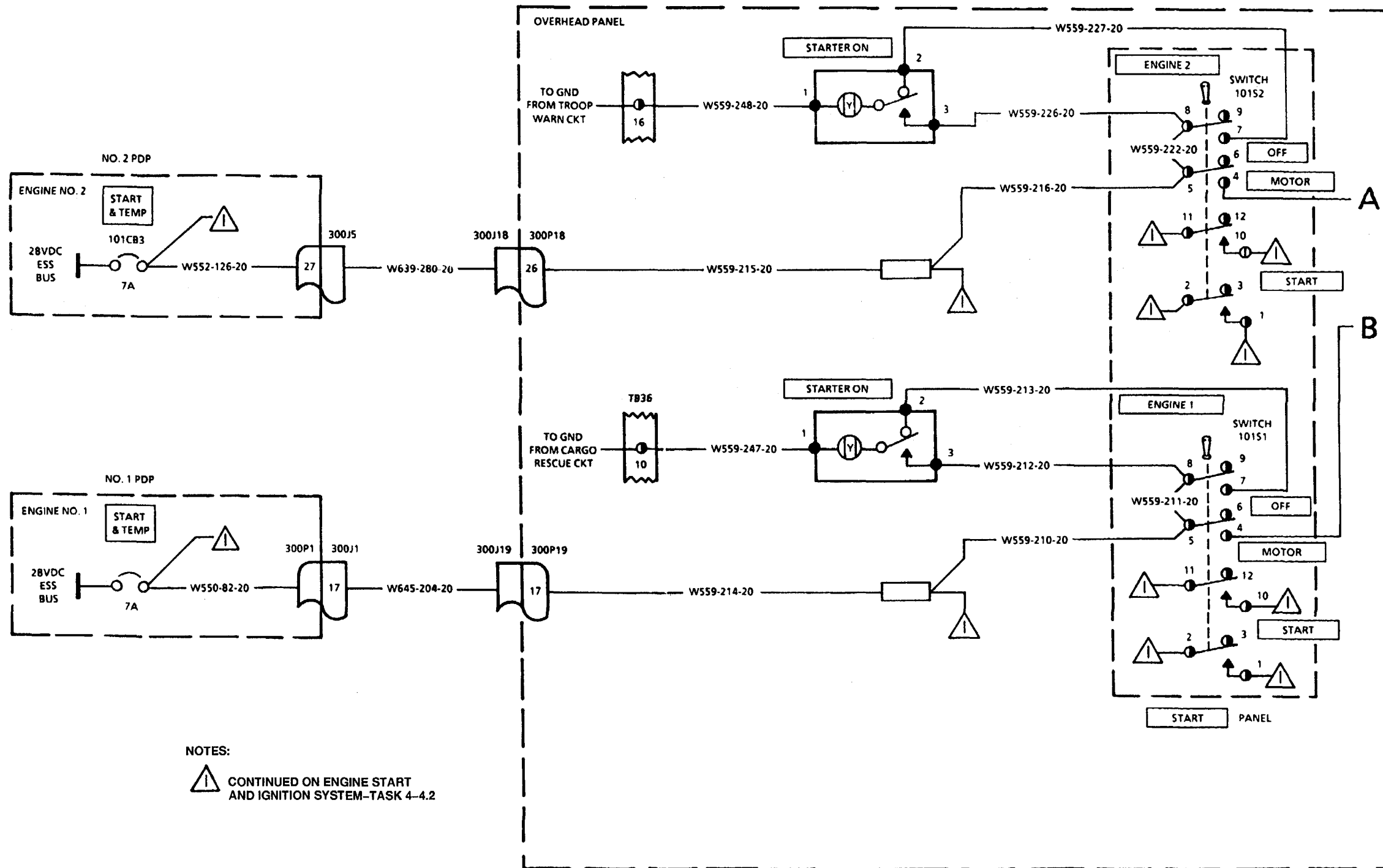

NOTES:
 CONTINUED ON ENGINE START AND IGNITION SYSTEM-TASK 4-4.2

A72528

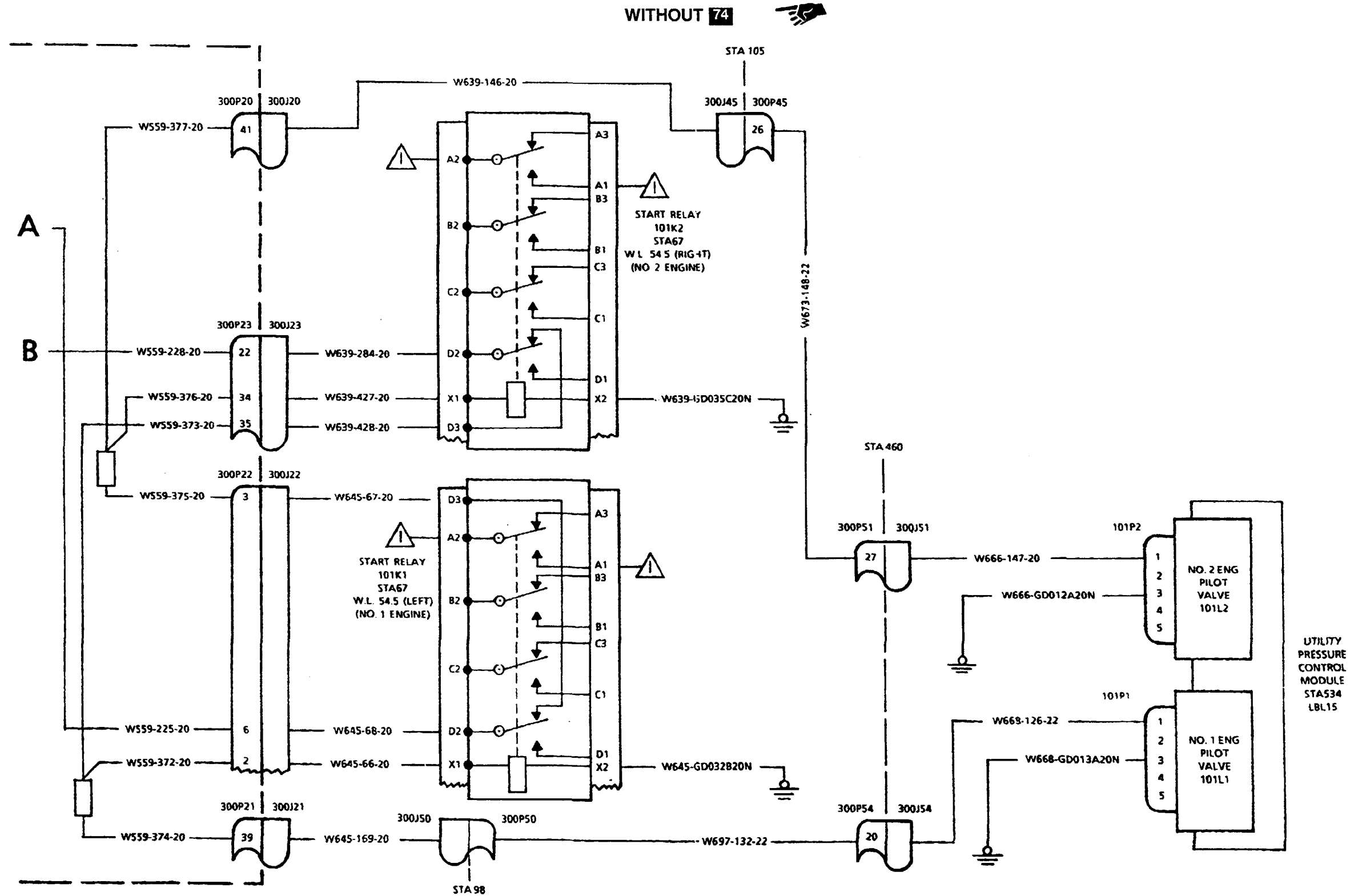

A72509

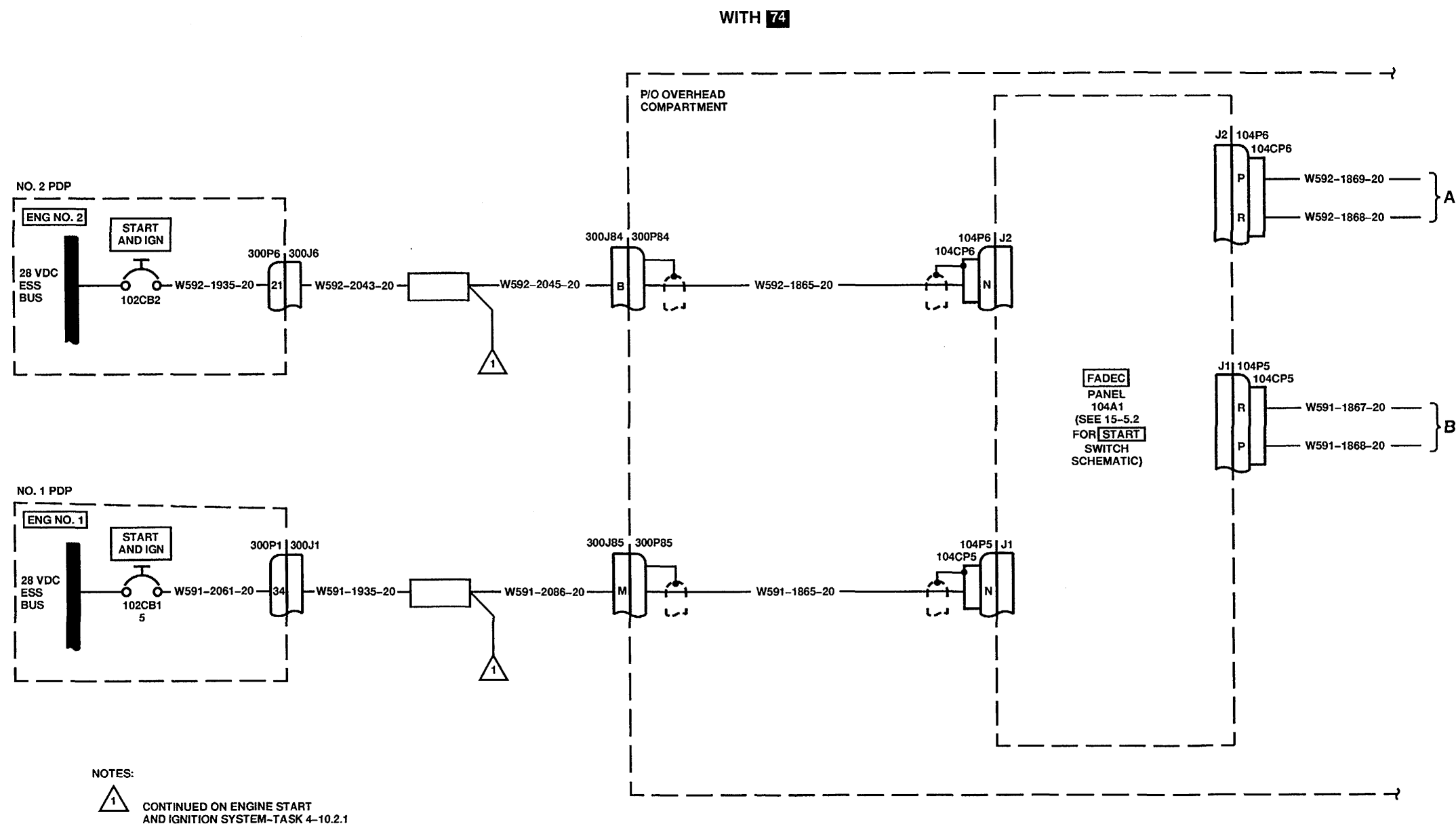

A72510

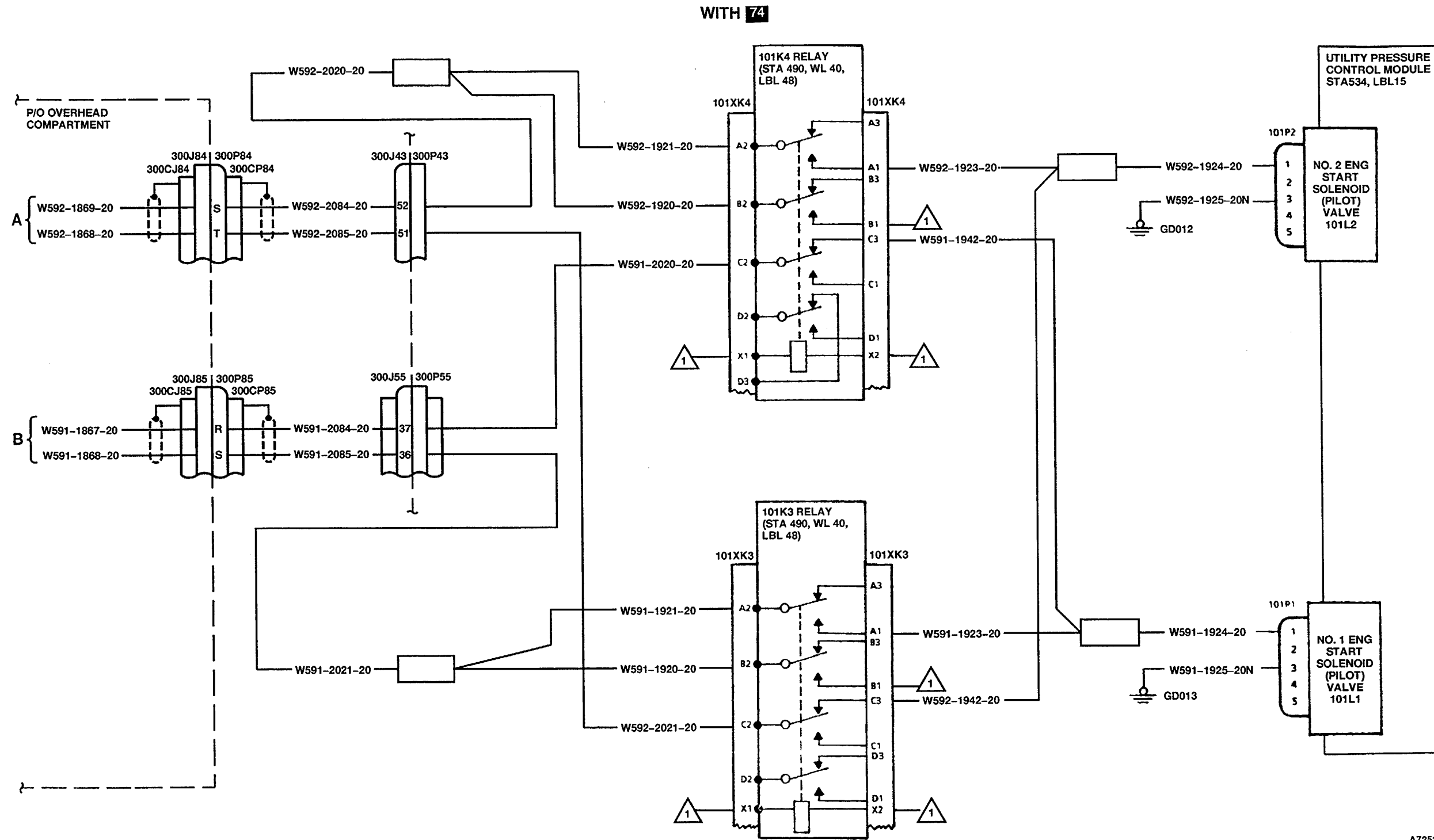

A72511

END OF TASK
Change 23 15-94.1

15-5.4 ENGINE HYDRAULIC STARTING SYSTEM VISUAL CHECK

15-5.4

INITIAL SETUP

Applicable Configurations:

All **Equipment Condition:**

Tools:

Aircraft Mechanic's Tool Kit,
NSN 5180-00-323-4692

Materials:

None

Personnel Required:

Medium Helicopter Repairer

References:

TM 551520-240-23

TM 55-1520-240-23:

- Battery Disconnected
- Electrical Power Off
- Hydraulic Power Off
- No. 1 or No. 2 Engine Work Platforms and Access Doors Open

TASK	RESULT
CHECK NO. 1 ENGINE STARTER INSTALLATION	
1. Check No. 1 engine starter (1).	If starter (1) is loose or damaged, tighten or replace it as required.
2. Check disconnect couplings (2 and 3) for extended buttons (4) or evidence of leaks.	If coupling (2 or 3) is not secured or buttons (4) are not extended, connect coupling. If buttons are still not extended, replace coupling. If buttons are extended and leaks are evident, repair or replace coupling or replace hose.
CHECK NO. 2 ENGINE STARTER INSTALLATION	
3. Check No. 2 engine starter (1).	If starter (1) is loose or damaged, tighten or replace it as required.
4. Check disconnect couplings (5 and 6) for extended buttons (4) or evidence of leaks.	If coupling (5 or 6) is not secured or buttons (4) are not extended, connect coupling. If buttons are still not extended, replace coupling. If buttons are extended and leaks are evident, repair or replace coupling or replace hose.

FOLLOW-ON MAINTENANCE:

TM 55-1520-240-23:

Close No. 1 or No. 2 engine work platform and access door.

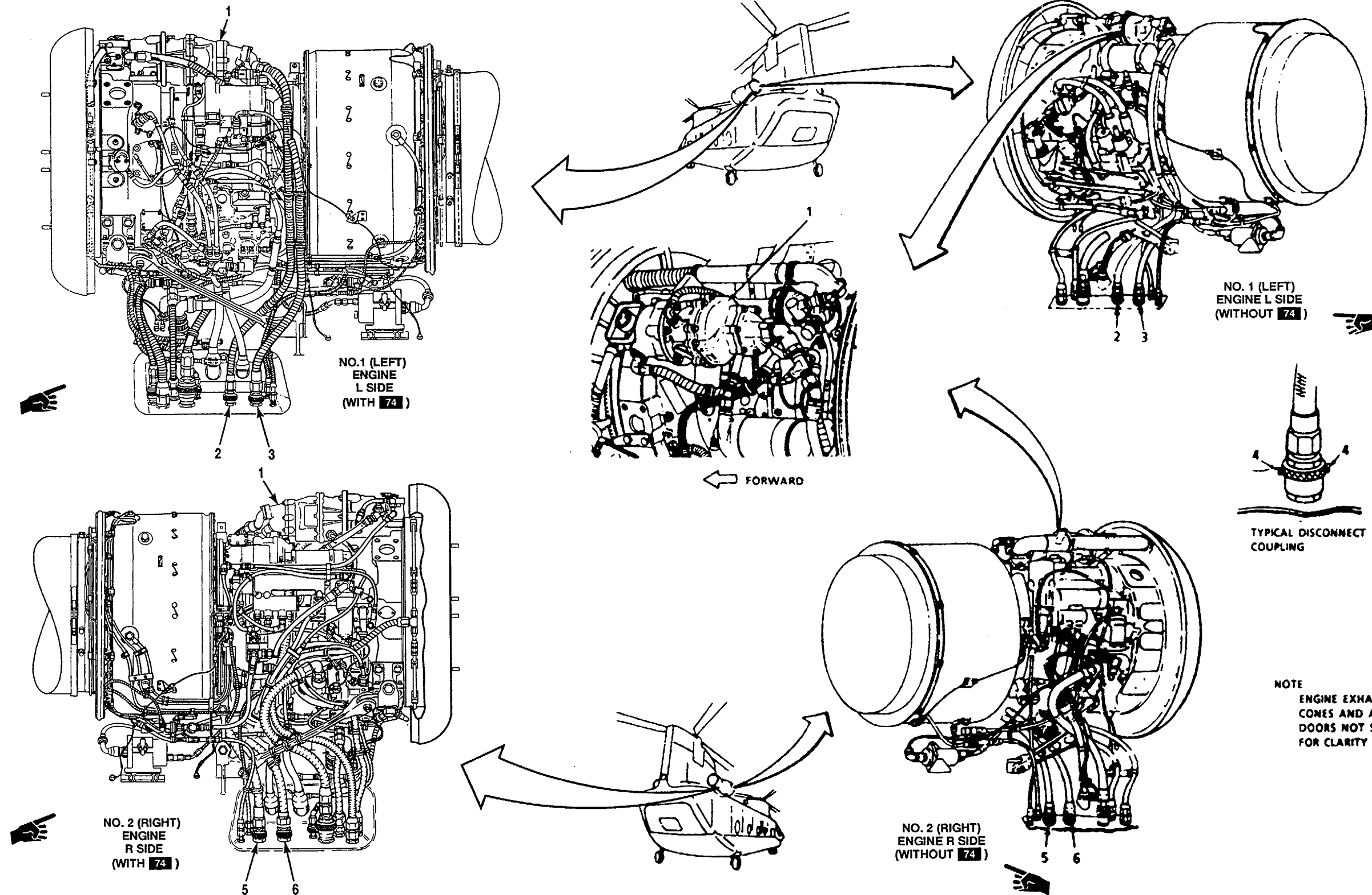

A72522

15-5.5 ENGINE HYDRAULIC STARTING SYSTEM OPERATIONAL CHECK

INITIAL SETUP

Applicable Configurations:

- Without 74

Tools:

None

Materials:

None

Personnel Required:

Medium Helicopter Repairer (2)

References:

TM 55-1520-240-23

Equipment Condition:

- TM 55-1520-240-23:
- Battery Connected
- Electrical Power On
- Hydraulic Power On
- Ignition Switch Key Removed

General Safety Instructions:

WARNING

Make sure that rotor blades are clear of obstructions and that personnel are aware that rotor blades may turn during engine motoring. Turning blades can cause damage or serious injury to personnel.

TASK	RESULT
1. Check that ENGINE NO. 1 START & TEMP circuit breaker (1) is closed.	If START & TEMP circuit breaker (1) is open, close it. If it opens again, go to task 4-4.6.
2. Check that ENGINE NO. 2 START & TEMP circuit breaker (2) is closed.	If START & TEMP circuit breaker (2) is open, close it. If it opens again, go to task 4-4.8.
3. Press and release ENGINE 1 STARTER ON light (3).	Light (3) shall momentarily come on. If it does not light, go to task 4-4.9.
4. Press and release ENGINE 2 STARTER ON light (4).	Light (4) shall momentarily come on. If it does not light, go to task 4-4.10.
MOTOR NO. 1 ENGINE	
5. Set ENGINE 1 START switch (5) to MOTOR.	ENGINE 1 STARTER ON light (3) shall come on. NO. 1 ENGINE gas producer tachometer (6) shall indicate 10 to 15% N1 as starter motors engine. If ENGINE 1 STARTER light does not come on, go to task 4-4.9. If engine does not motor, go to task 15-5.6.

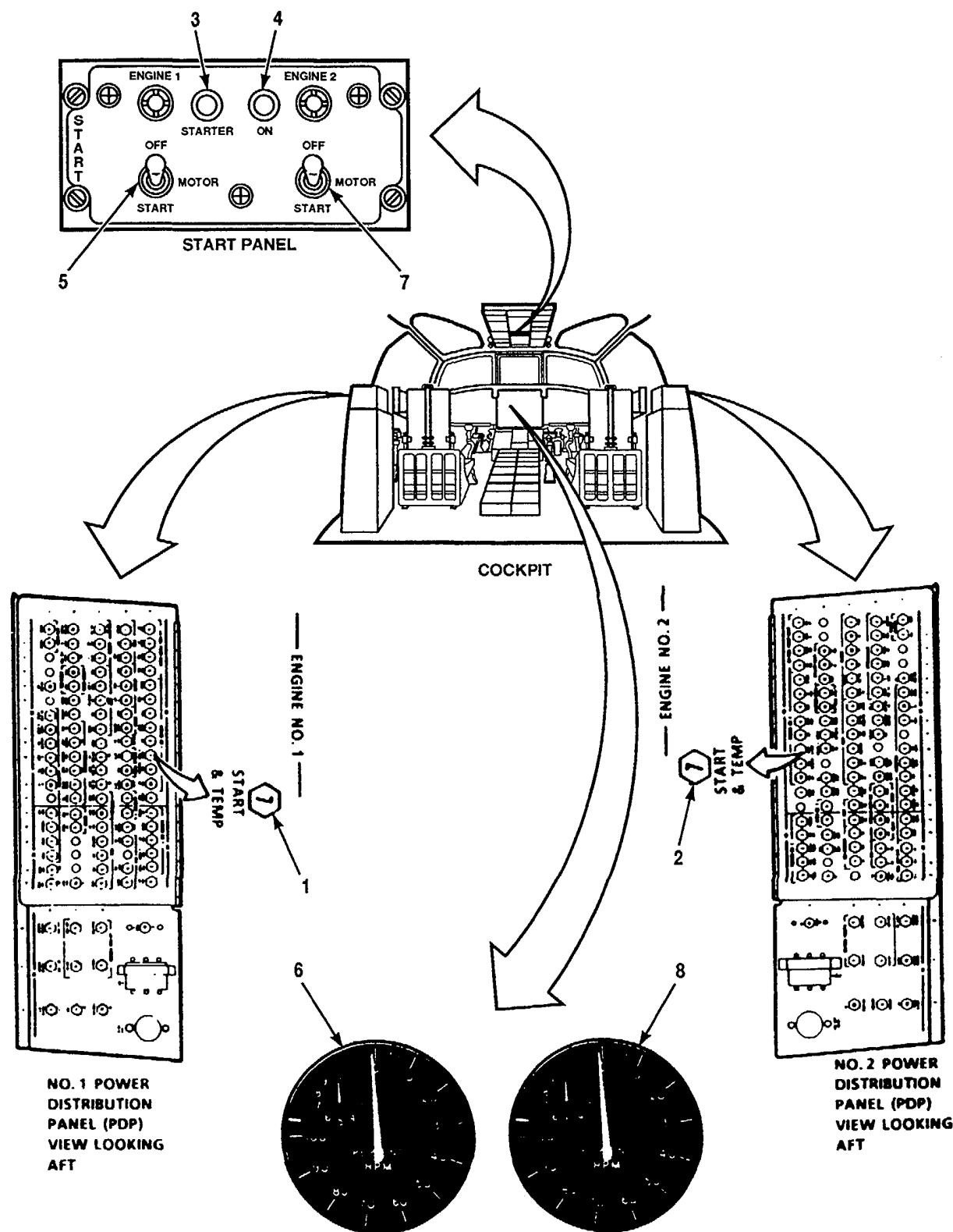

A72527

TASK	RESULT
6. Set ENGINE 1 START switch (5) to OFF.	NO. 1 ENGINE gas producer tachometer (6) indication shall decrease to 0. If tachometer indication does not decrease or engine continues to motor, go to task 15-5.7.
MOTOR NO. 2 ENGINE	
7. Set ENGINE 2 START switch (7) to MOTOR.	ENGINE 2 STARTER ON light (4) shall come on. NO. 2 ENGINE gas producer tachometer (8) shall indicate 10 to 15% N1 as starter motors engine. If ENGINE 2 STARTER light does not come on, go to task 4-4.10. If engine does not motor, go to task 15-5.6.
8. Set ENGINE 2 START switch (7) to OFF.	NO. 2 ENGINE gas producer tachometer (8) indication shall decrease to 0. If tachometer indication does not decrease or engine continues to motor, go to task 15-5.7.

FOLLOW-ON MAINTENANCE:

TM 55-1520-240-23:

Battery disconnected.

Electrical power off.

Hydraulic power off.

15-5.5.1 ENGINE HYDRAULIC STARTING SYSTEM OPERATIONAL CHECK

INITIAL SETUP

Applicable Configurations:
With 74

Tools:

None

Materials:

None

Personnel Required:

Medium Helicopter Repairer (2)

References:

TM 55-1520-240-23

Equipment Condition:

TM 55-1520-240-23:
Battery Connected
Electrical Power On
Hydraulic Power On
Ignition Switch Off (Key Removed)
General Safety Instructions:

WARNING

Make sure that rotor blades are clear of obstructions and that personnel are aware that rotor blades may turn during engine motoring. Turning blades can cause damage or serious injury to personnel.

TASK	RESULT
1. Check that ENGINE NO. 1 START & IGN circuit breaker (1) is closed.	If START & IGN circuit breaker (1) is open, close it. If it opens again, go to task 4-10.4.
2. Check that ENGINE NO. 2 START & IGN circuit breaker (2) is closed.	If START & IGN circuit breaker (2) is open, close it. If it opens again, go to task 4-10.4.
3. Check that ENGINE NO. 1 and ENGINE NO. 2 PRI CONT circuit breakers (3) and (4) are opened.	If PRI CONT circuit breakers (3) and (4) are closed, open them.
4. Check that ENGINE NO. 1 and ENGINE NO. 2 REV CONT circuit breakers (5) and (6) are opened.	IF REV CONT circuit breakers (5) and (6) are closed, open them.
MOTOR NO. 1 ENGINE	
5. On the FADEC panel, set and hold ENG START switch (7) to 1.	The NO. 1 ENGINE N1 tachometer (8) must indicate <u>10 to 15% N1</u> as starter motors engine. If the engine does not motor, go to task 15-5.6.1.
6. Release the ENG START switch (7) to its center position.	The NO. 1 ENGINE N1 tachometer (8) indication must decrease to <u>0% N1</u> . If the tachometer indication does not decrease or the engine continues to motor, go to task 15-5.7.

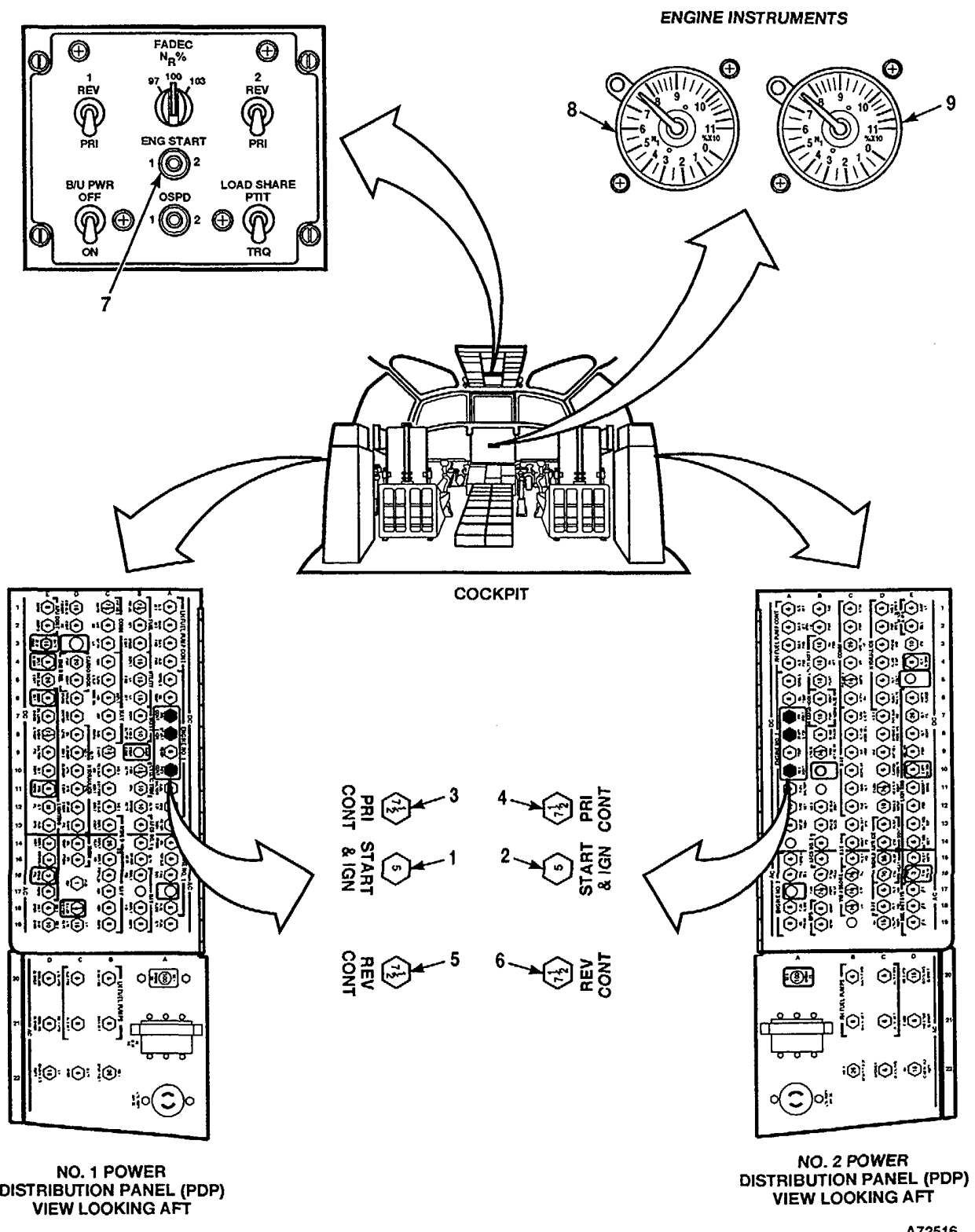

TASK	RESULT
MOTOR NO. 2 ENGINE	
7. On the FADEC panel, set and hold ENG START switch (7) to 2.	The NO. 2 ENGINE 2 N1 tachometer (9) must indicate <u>10 to 15% N1</u> as starter motors engine. If the engine does not motor, go to task 15-5.6.1.
8. Release the ENG START switch (7) to its center position.	The NO. 2 ENGINE (9) indication must decrease to <u>0% N1</u> . If the tachometer indication does not decrease or the engine continues to motor, go to task 15-5.7.

FOLLOW-ON MAINTENANCE:

TM 55-1520-240-23:

Battery disconnected.

Electrical power off.

Hydraulic power off.

15-5.6 NO. 1 OR NO. 2 ENGINE DOES NOT MOTOR (HYDRAULIC SYSTEM)

FAULT ISOLATION PROCEDURE

INITIAL SETUP

Applicable Configurations:

Without 74

Tools:

Aircraft Mechanic's Tool Kit,
NSN 5180-00-3234692

Materials:

None

Personnel Required:

Medium Helicopter Repairer (2)

References:

TM 55-1520-240-23

Equipment Condition:

TM 55-1520-240-23:

Battery Connected

Electrical Power On

Hydraulic Power On

No. 1 or No. 2 Engine Work Platforms and

Access Doors Open

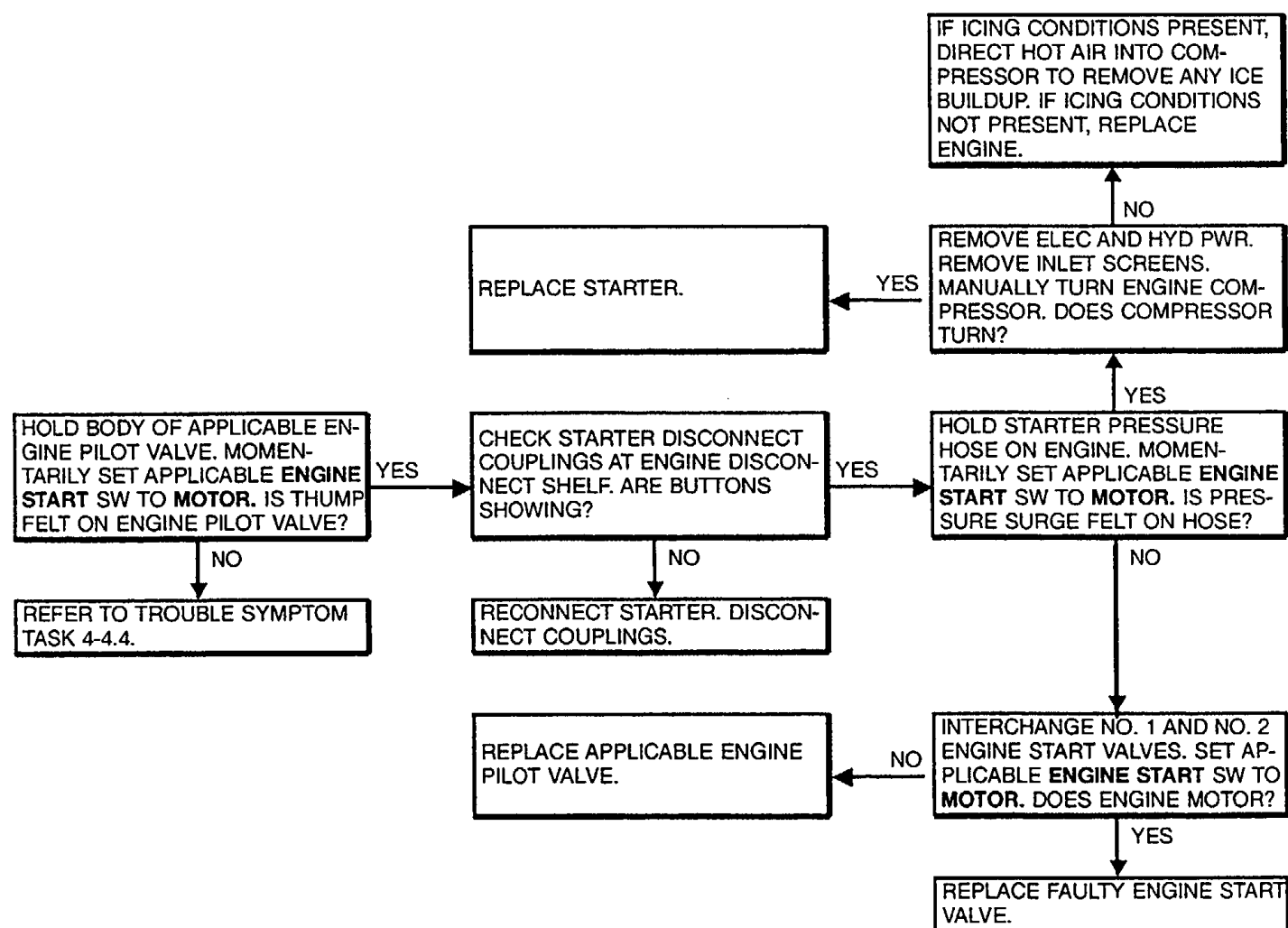
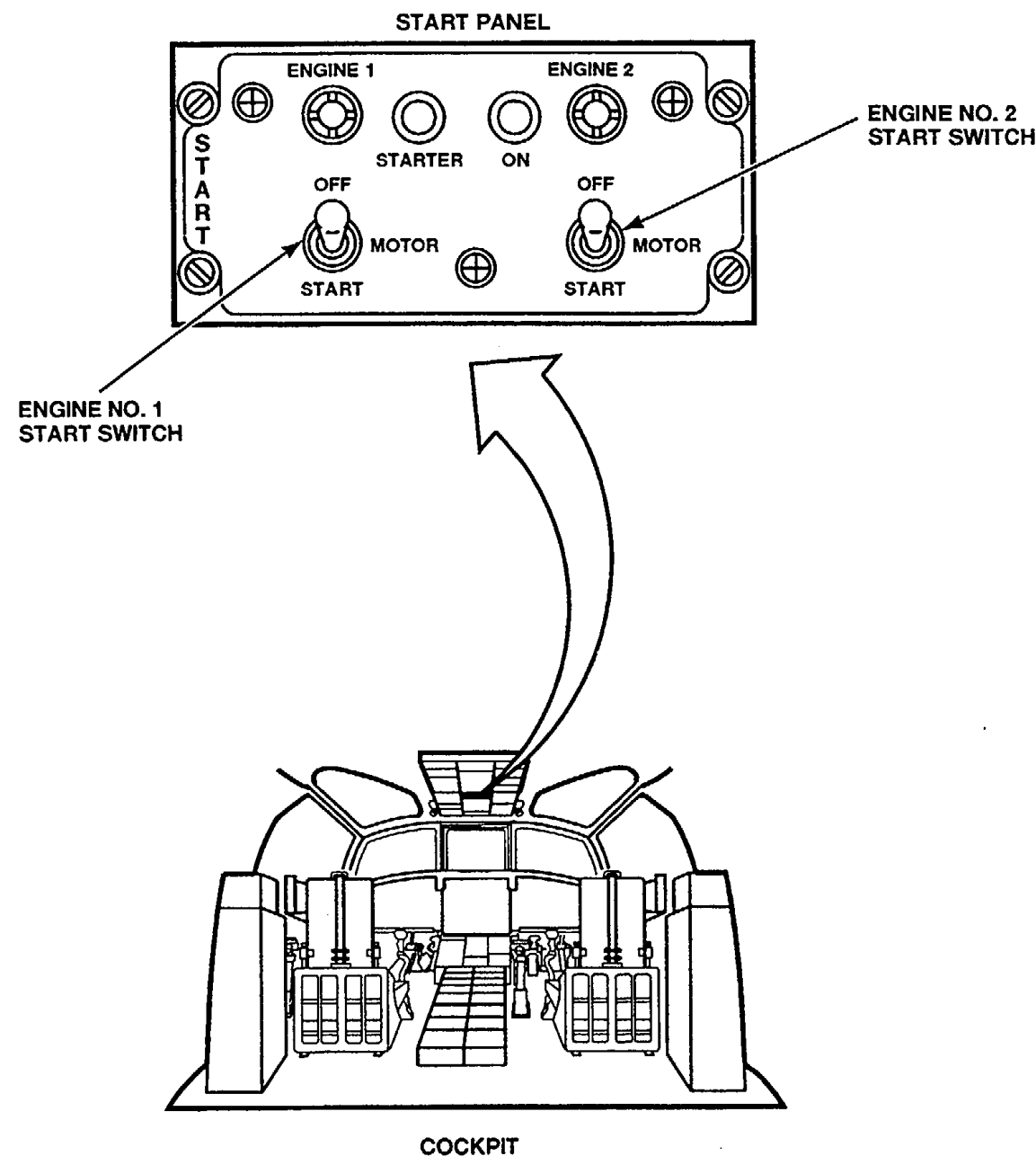

WITHOUT **74** 

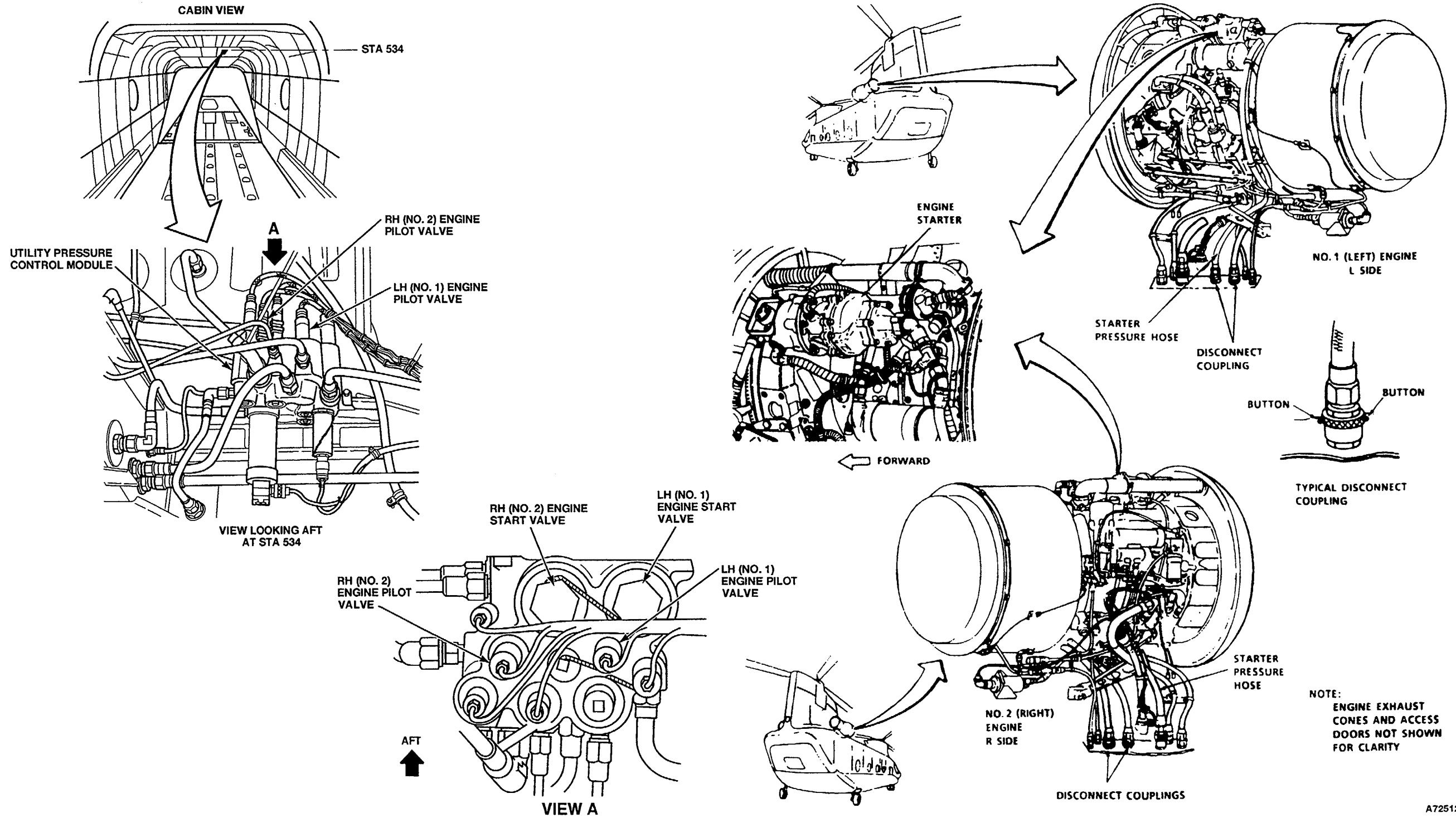

FAULT ISOLATION PROCEDURE

INITIAL SETUP

Applicable Configurations:

With **74**

Tools:

Aircraft Mechanic's Tool Kit,
NSN 5180-00-323-4692

Materials:

None

Personnel Required:

Medium Helicopter Repairer (2)

References:

TM 55-1520-240-23

Equipment Condition:

TM 55-1520-240-23:
Battery Connected
Electrical Power On
Hydraulic Power On
No. 1 or No. 2 Engine Work Platforms and
Access Doors Open

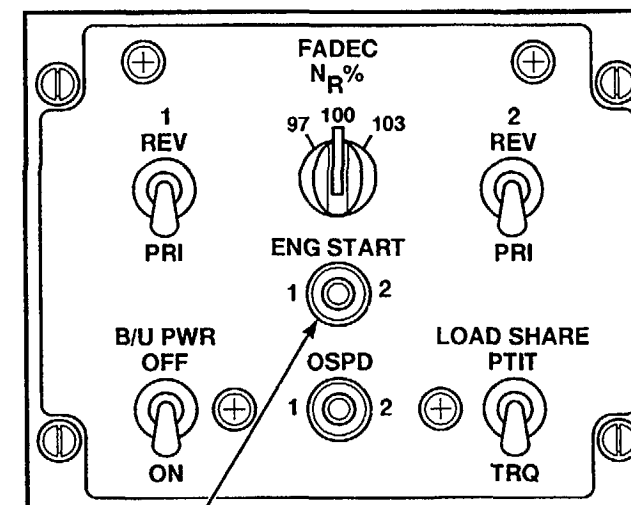
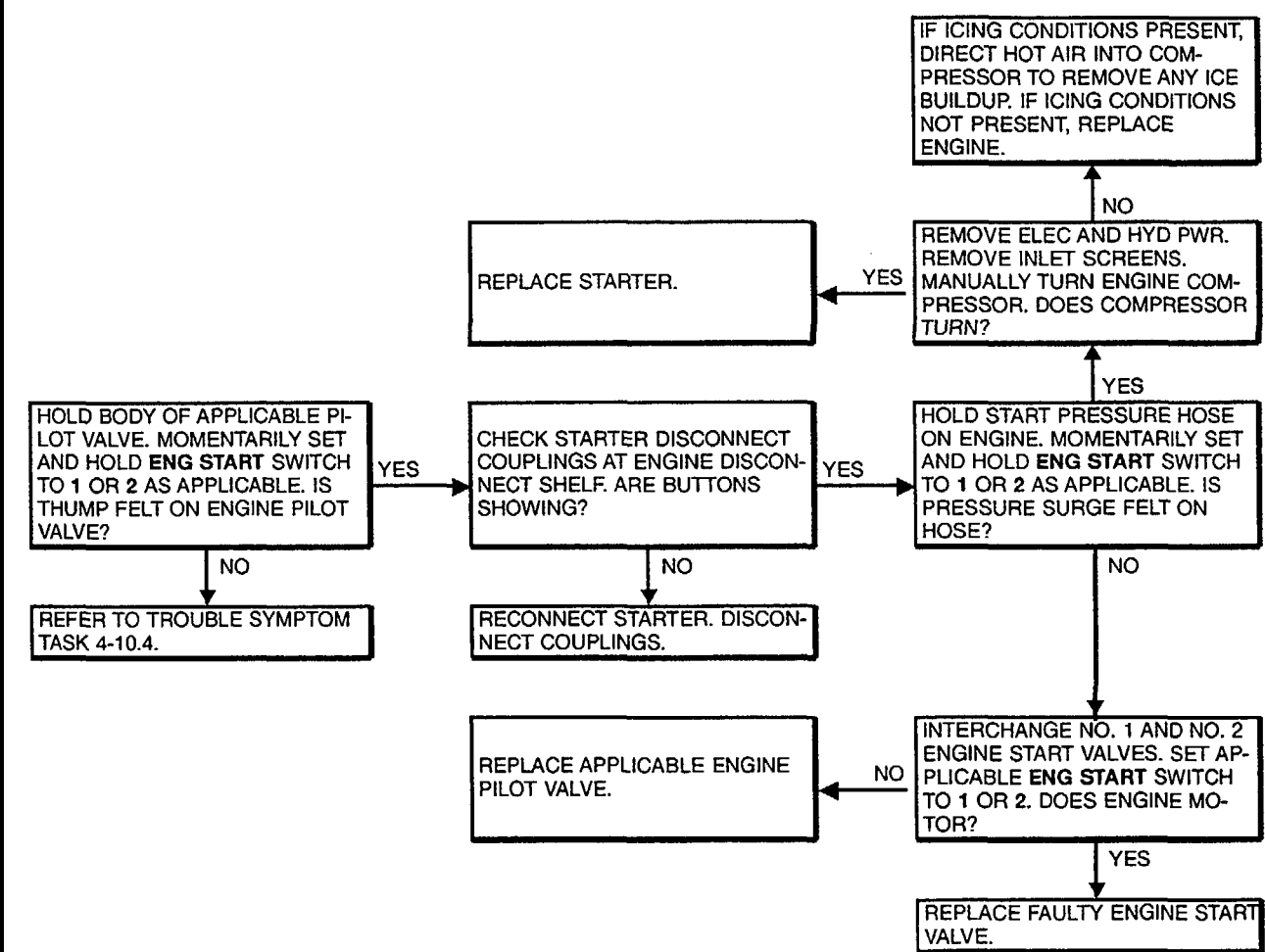

FADEC PANEL
ENG START SWITCH

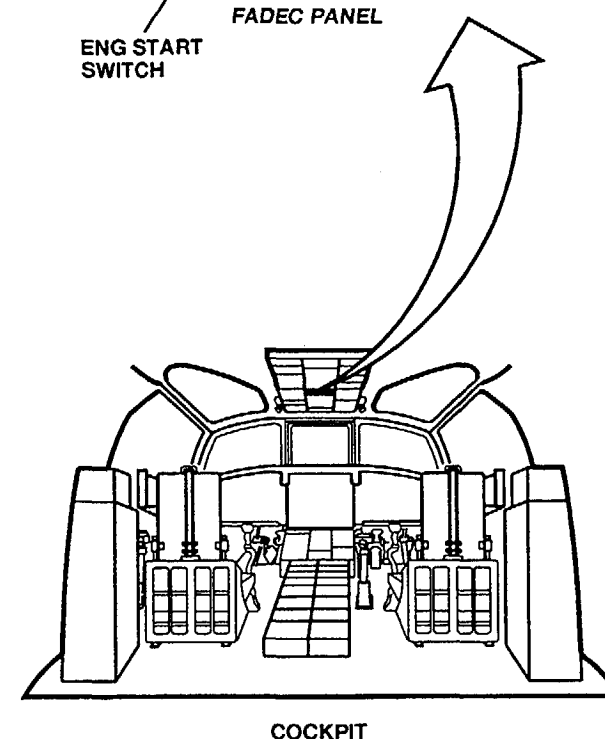

COCKPIT

WITH 74

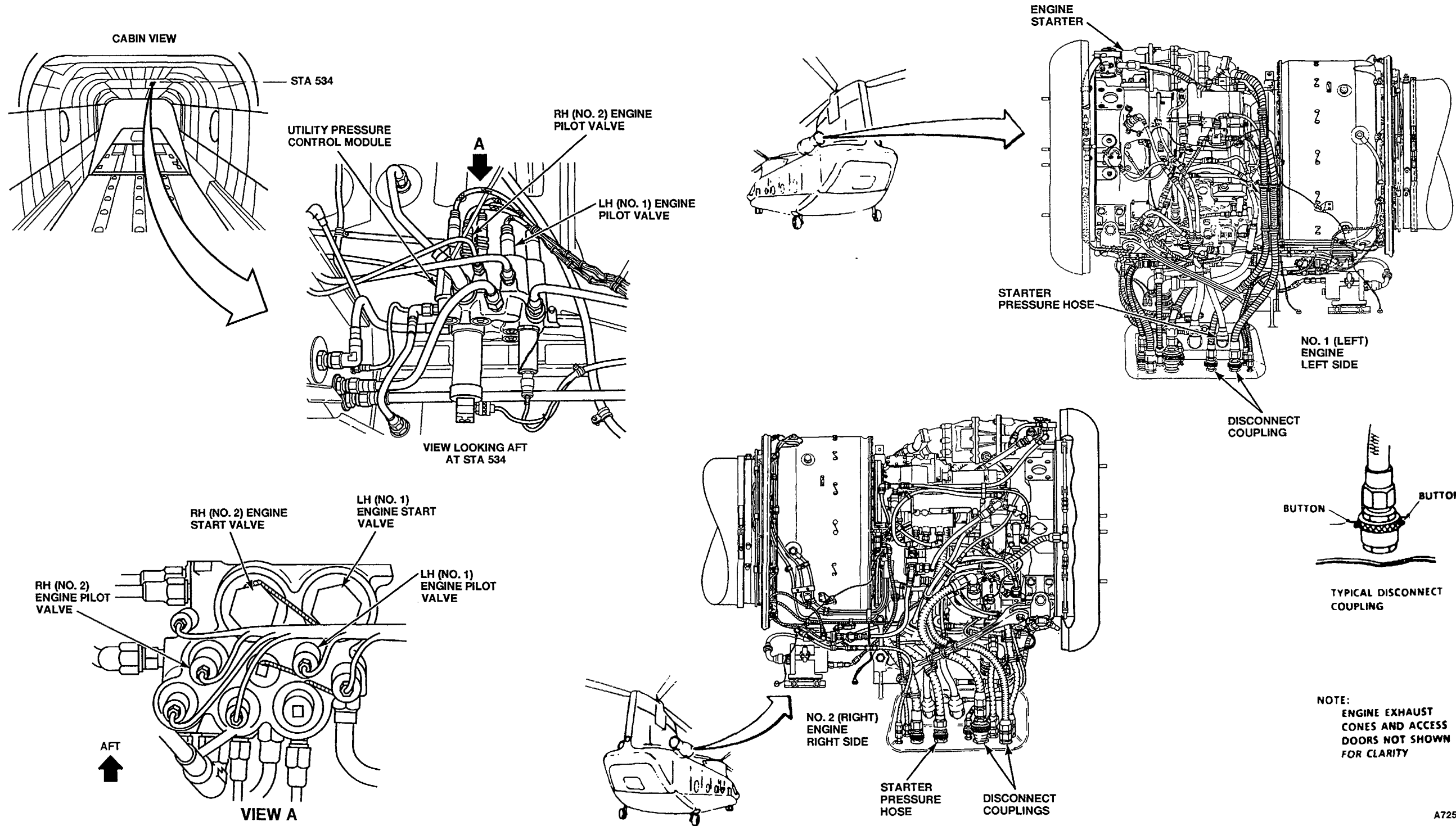

A72513

15-5.7 NO. 1 OR NO. 2 ENGINE KEEPS MOTORING WHEN ENGINE START SWITCH SET TO OFF

FAULT ISOLATION PROCEDURE

INITIAL SETUP

Applicable Configurations:
All

Tools:
Aircraft Mechanic's Tool Kit,
NSN 5180-00-323-4692

Materials:
None

Personnel Required:
Medium Helicopter Repairer (2)

References:
TM 5-1520-240-23

Equipment Condition:
TM 55-1520-240-23
Battery Connected
Electrical Power On
Hydraulic Power On

WITHOUT 74:

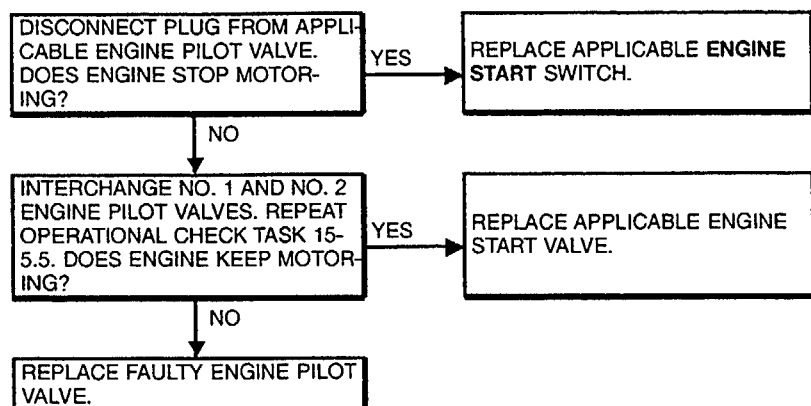

WITHOUT 74:

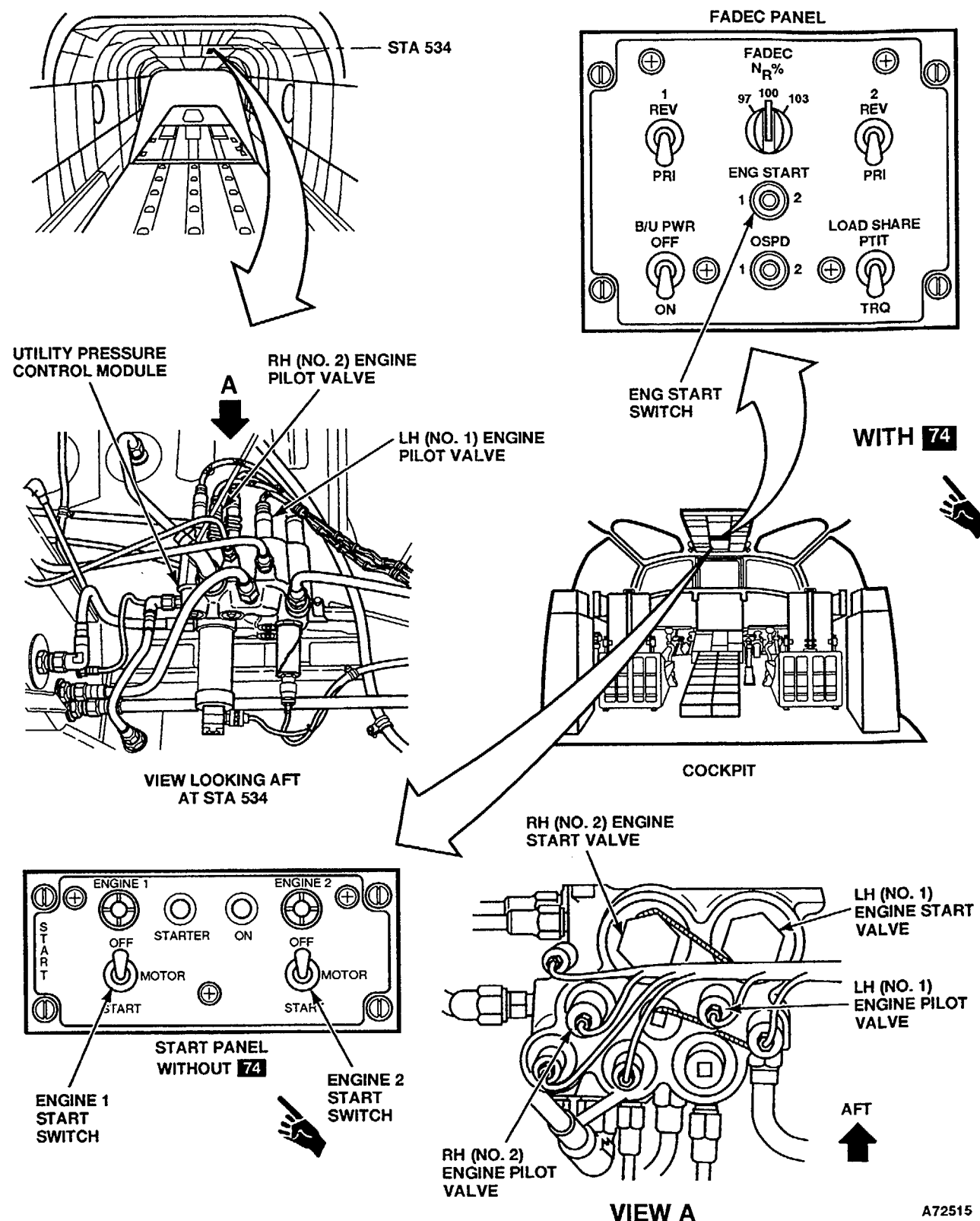
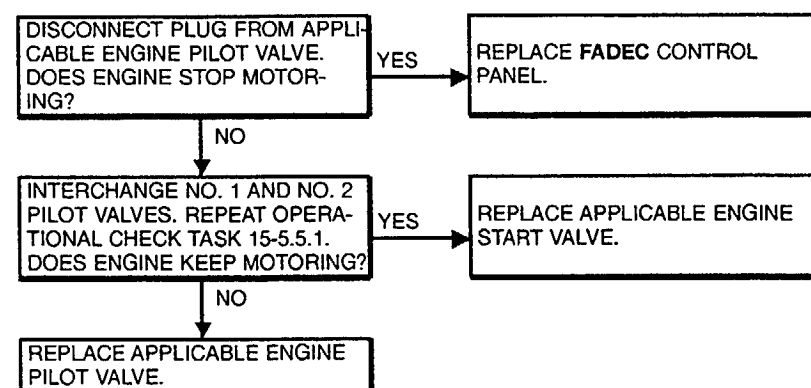

15-6 MICROPROCESSOR ELECTRONIC SEQUENCE UNIT (ESU)

PARAGRAPH 15-6

TABLE OF CONTENTS

APU MICROPROCESSOR ELECTRONIC SEQUENCE UNIT (ESU) TROUBLESHOOTING

PARAGRAPH	DESCRIPTION	FUNCTION	PAGE	PARAGRAPH	DESCRIPTION	FUNCTION	PAGE
15-6	APU MICROPROCESSOR ELECTRONIC SEQUENCE UNIT (ESU)		15-101	15-6.12	APU MOTORS BUT DOES NOT START , ESU BITE INDICATES ●●●● OR ○○●● THEN ●○○● (FAILURE TO START)	TASK	15-119
15-6.1	ESU COMPONENTS	DRAWING	15-105	15-6.13	APU MOTORS BUT DOES NOT START, ESU BITE INDICATES ○○○● THEN ●○○● (FAILURE TO START)	TASK	15-123
15-6.2	APU SYSTEMS BITE INDICATION FAILURE TABLE	TABLE	15-106	15-6.14	APU STARTS BUT SHUTS DOWN, ESU BITE INDICATES ●●○○ (OVERSPEED)	TASK	15-127
15-6.3	APU STARTING SEQUENCE FAILURE AND ESU P.C. BOARDS FAILURE TABLES	TABLES	15-109	15-6.15	APU STARTS BUT SHUTS DOWN, ESU BITE INDICATES ○○○● (UNDERSPEED)	TASK	15-129
15-6.4	ESU SYSTEM SCHEMATIC	DRAWING	15-110	15-6.16	APU STARTS BUT SHUTS DOWN, ESU BITE INDICATES ○○●● (OVERTEMPERATURE)	TASK	15-131
15-6.5	ESU SYSTEM WIRING DIAGRAM	DRAWING	15-111	15-6.17	APU STARTS AND RUNS THEN SHUTS DOWN, ESU BITE INDICATES ○○●● (OVERTEMPERATURE) (HOT START)	TASK	15-133
15-6.6	ESU BLOCK DIAGRAM	DRAWING	15-112	15-6.18	APU STARTS BUT SHUTS DOWN, ESU BITE INDICATES ●●○○ (OPEN THERMOCOUPLE)	TASK	15-135
15-6.7	INITIALIZING BITE LOGIC BLOCK DIAGRAM	DRAWING	15-113	15-6.19	APU STARTS AND RUNS BUT ESU BITE INDICATES ●○○○ (SHORTED THERMO. PROBE) (WARNING)	TASK	15-136
15-6.8	NORMAL START BITE LOGIC BLOCK DIAGRAM	DRAWING	15-114				
15-6.9	MALFUNCTION BITE LOGIC BLOCK DIAGRAM (BEFORE START)	DRAWING	15-115				
15-6.10	MALFUNCTION BITE LOGIC BLOCK DIAGRAM (DURING STARTING AND RUNNING)	DRAWING	15-116				
15-6.11	APU MOTORS BUT DOES NOT START, ESU BITE INDICATES ○●○○ (NO SPEED DATA)	TASK	15-117				

PARAGRAPH 15-6
LIST OF TABLES
ELECTRONIC SEQUENCE UNIT (ESU) TROUBLESHOOTING

TABLE NO.	DESCRIPTION	PAGE NO.
15-6.1	BITE INDICATION TABLE FOR APU SYSTEMS FAILURES	15-106
15-6.2	APU STARTING SEQUENCE FAILURES - BITE INDICATION TABLE	15-109
15-6.3	ESU PRINTED CIRCUIT BOARD FAILURES - BITE INDICATION TABLE	15-109

15-6 ELECTRONIC SEQUENCE UNIT (ESU)

15-6

15-6.1 ESU COMPONENTS

15-6.1

BITE				DECODED BITE INFORMATION	
1	2	3	4		
●	●	●	●	RESET	START SEQUENCE
○	●	●	●	START FUEL VALVE & EXCITER SIGNAL OUT (5%)	
○	○	●	●	MAIN FUEL VALVE SIGNAL OUT (14%)	
○	○	○	●	START FUEL VALVE & EXCITER SIGNAL OFF (70%)	
○	○	○	○	90% RPM SWITCH ON	
●	●	●	●	READY FOR SERVICE (90% + 1.5 SEC.)	OPERATION
○	●	●	●	PROCESSOR BOARD FAILURE	
●	○	●	●	SENSOR /DATA BOARD FAILURE	
○	○	●	●	OVERTEMPERATURE	
●	●	○	●	OVERSPEED	
○	●	○	●	UNDERSPEED	
●	○	○	●	FAILURE TO START	
●	○	●	○	SHORTED THERMOCOUPLE PROBE (WARNING)	
●	●	○	○	OPEN THERMOCOUPLE	
●	○	○	○	PROCESSOR SEQUENCE FAIL	
○	○	○	○	NO TEMP DATA	
○	●	○	○	NO SPEED DATA	

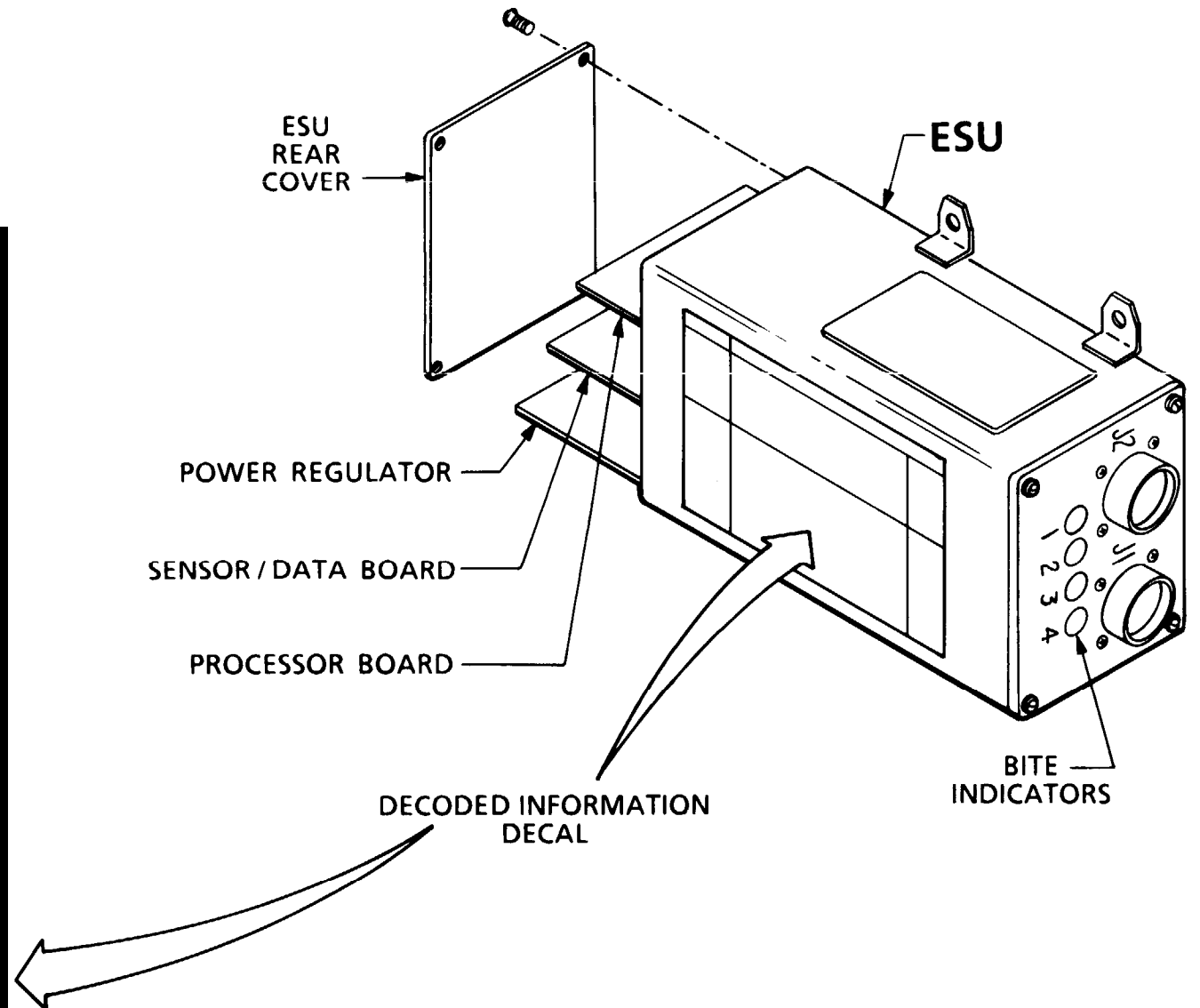

TABLE NO. 15-6.1 BITE INDICATION TABLE FOR APU SYSTEMS FAILURES				
NO.	BITE INDICATION	SYMPTOM	DECODED BITE DESCRIPTION	Maintenance Action
				Task No.
APU DOES NOT MOTOR:				
1	○●●●	ESU Bite indicates ○●●●	PROCESSOR BOARD FAILURE	15-2.10
2	●○●●	ESU Bite indicates ●○●●	SENSOR / DATA BOARD FAILURE	15-2.10
3	●○○○	ESU Bite indicates ●○○○	PROCESSOR SEQUENCE FAIL	15-2.10
4	○○○○	ESU Bite indicates ○○○○	NO TEMP DATA	15-2.10
APU MOTORS BUT DOES NOT START:				
5	○○●● then ●○○●	ESU Bite indicates ●○○●	FAILURE TO START	15-3.6
6	○○○● then ●○○●	ESU Bite indicates ●○○●	FAILURE TO START	15-3.7
7	○●●● or ○○●● then ●○○●	ESU Bite indicates ●○○●	FAILURE TO START	15-4.11
8	○●○○	ESU Bite indicates ○●○○	NO SPEED DATA	15-6.11
9	○●●● or ○○●● then ●○○●	ESU Bite indicates ●○○●	FAILURE TO START	15-6.12
10	○○○● then ●○○●	ESU Bite indicates then ●○○●	FAILURE TO START	15-6.13

TABLE NO. 15-6.1 BITE INDICATION TABLE FOR APU SYSTEMS FAILURES (Continued)				
NO.	BITE INDICATION	SYMPTOM	DECODED BITE DESCRIPTION	Maintenance Action
				Task No.
APU STARTS BUT SHUTS DOWN				
11	○○○○ then ●●○○	ESU Bite indicates ●●○○	OVERSPEED	15-6.14
12	○○○● then ○○○●	ESU Bite indicates ○●○○	UNDERSPEED	15-6.15
13	○○○● then ○○●●	ESU Bite indicates ○○●●	OVERTEMPERATURE (HOT START)	15-6.16
14	○○●● then ●●○○	ESU Bite indicates ●●○○	OPEN THERMOCOUPLE	15-6.18
APU STARTS AND RUNS BUT SHUTS DOWN				
15	○○○○ then ○○●●	ESU Bite indicates ○○●●	OVERTEMPERATURE (HOT START)	15-6.17
APU STARTS AND RUNS				
16	●○○○	ESU Bite indicates ●○○○	SHORTED THERMO. PROBE (WARNING)	15-6.19
APU SHUTS DOWN WHEN GEN APU SWITCH PLACED TO ON				
17	●●●●	ESU Bite indicates ●●●●	READY FOR SERVICE	15-2.14
APU SHUTS DOWN WHEN APU GEN SWITCH IS SET TO OFF				
18		ESU Bite indicates	READY FOR SERVICE	15-2.15
APU DOES NOT STOP				
19	●●●●	ESU Bite indicates ●●●●	READY FOR SERVICE	15-2.12

15-6.3 APU STARTING SEQUENCE FAILURE AND ESU P.C. BOARDS FAILURE TABLES

15-6.3

TABLE NO. 15-6.2 APU STARTING SEQUENCE FAILURES					
APU STARTING SEQUENCE	No.	SYMPTOM	BITE INDICATION	DECODED BITE INFORMATION	TASK
PRE START					
	1	APU DOES NOT MOTOR ESU Bite indicates	○ ○ ○ ○	NO TEMP DATA	15-2.10
MOTORING					
	2	APU MOTORS BUT DOES NOT START ESU Bite indicates	○ ● ○ ○	NO SPEED DATA	15-6.11
	3	APU MOTORS BUT DOES NOT START ESU Bite indicates	○ ● ● ● or then ○ ○ ● ● ● ○ ○ ●	FAILURE TO START	15-6.12
	4	APU MOTORS BUT DOES NOT START ESU Bite indicates	○ ○ ○ ● then ● ○ ○ ●	FAILURE TO START	15-6.13
STARTING					
	5	APU STARTS BUT SHUTS DOWN ESU Bite indicates	● ● ○ ●	OVERSPEED	15-6.14
	6	APU STARTS BUT SHUTS DOWN ESU Bite indicates	○ ● ○ ●	UNDERSPEED	15-6.15
	7	APU STARTS BUT SHUTS DOWN ESU Bite indicates	● ● ○ ○	OPEN THERMOCOUPLE	15-6.18
HOT START					
	8	APU STARTS BUT SHUTS DOWN ESU Bite indicates	○ ○ ● ●	OVERTEMPERATURE	15-6.17
STARTS AND RUNS					
	9	APU STARTS AND RUNS but ESU Bite indicates	● ○ ● ○	SHORTED THERMO. PROBE (warning)	15-6.19

TABLE NO. 15-6.3 ESU PRINTED CIRCUIT BOARD FAILURES - BITE INDICATION TABLE	
BITE INDICATION	BITE INFORMATION
○ ● ● ●	PROCESSOR BOARD FAILURE.
● ○ ● ●	SENSOR/DATA BOARD FAILURE.
● ○ ○ ○	PROCESSOR SEQUENCE FAIL

- NOTES:
- 1 REFER TO MALFUNCTION BLOCK DIAGRAMS 15-6 9 AND 15-6 10 FOR ADDITIONAL DETAILS
 - 2 REFER TO MALFUNCTION BLOCK DIAGRAMS 15-6 7 THROUGH 15-6 10 FOR ADDITIONAL DETAILS
 - 3 WITHOUT 74
 - 4 WITH 74
 - 5 INDICATES EQUIPMENT MARKINGS

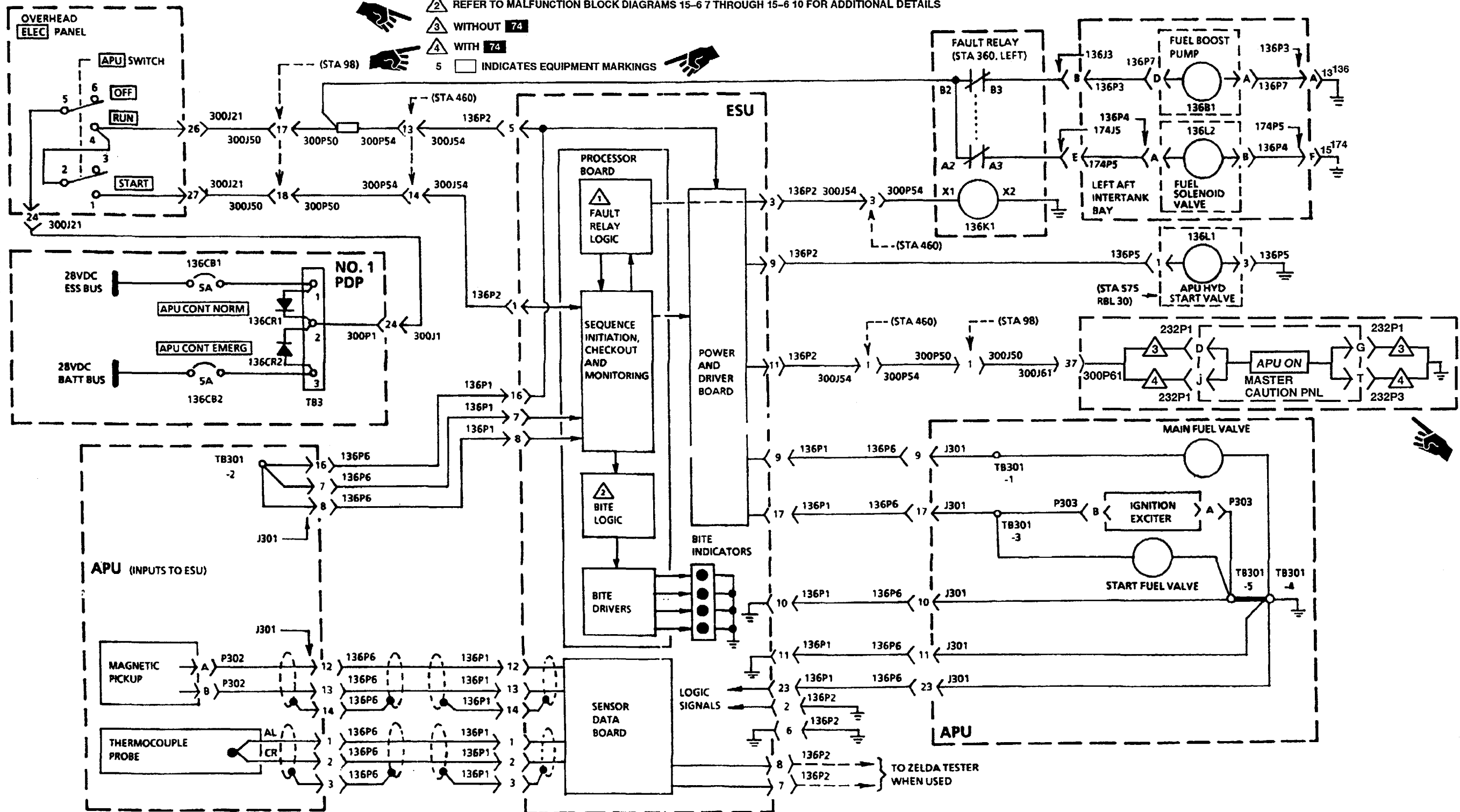

A72523

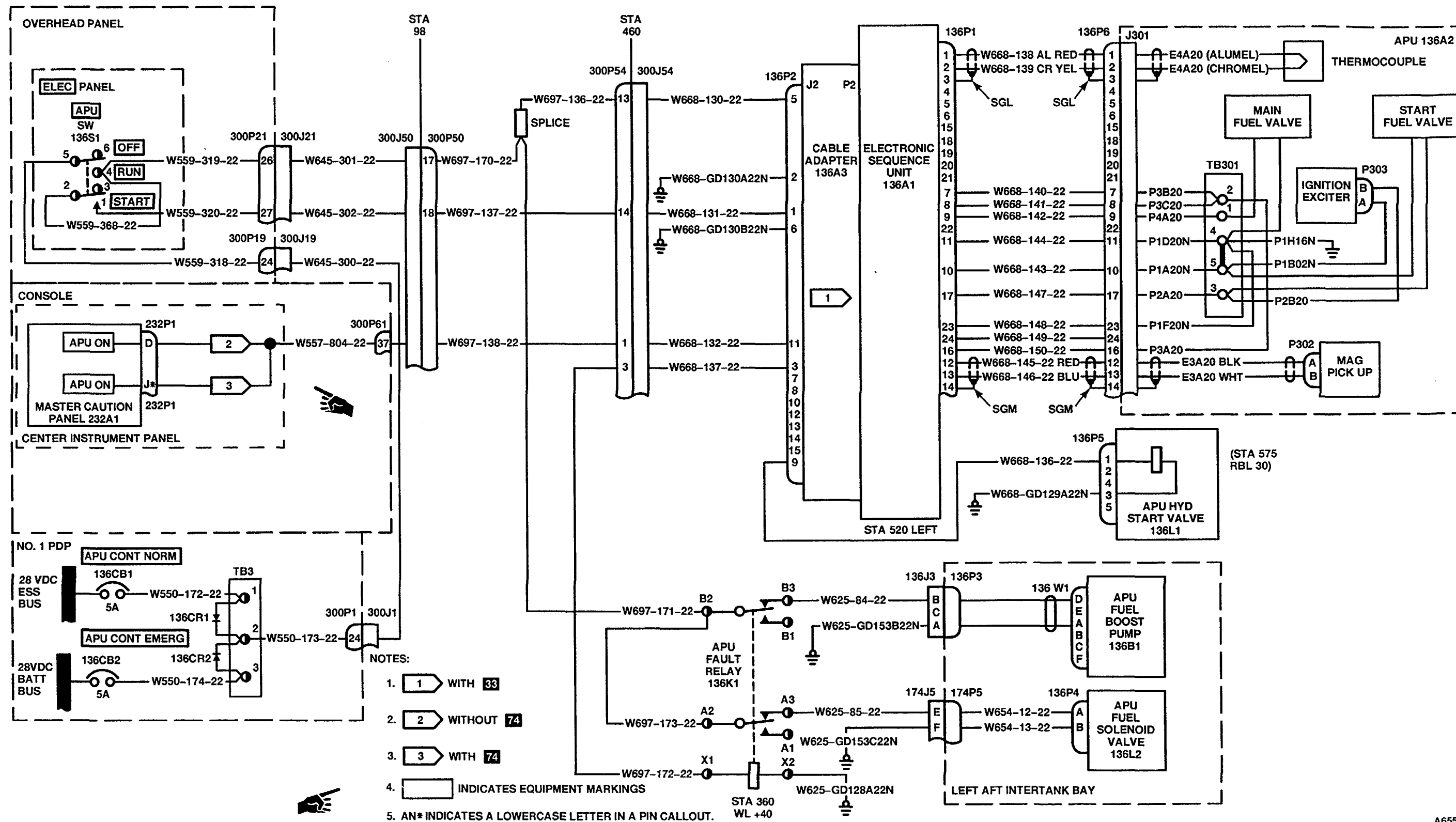

- NOTES:
1. WITH **33**
 2. WITHOUT **74**
 3. WITH **74**
 4. INDICATES EQUIPMENT MARKINGS
 5. AN* INDICATES A LOWERCASE LETTER IN A PIN CALLOUT.

A65580

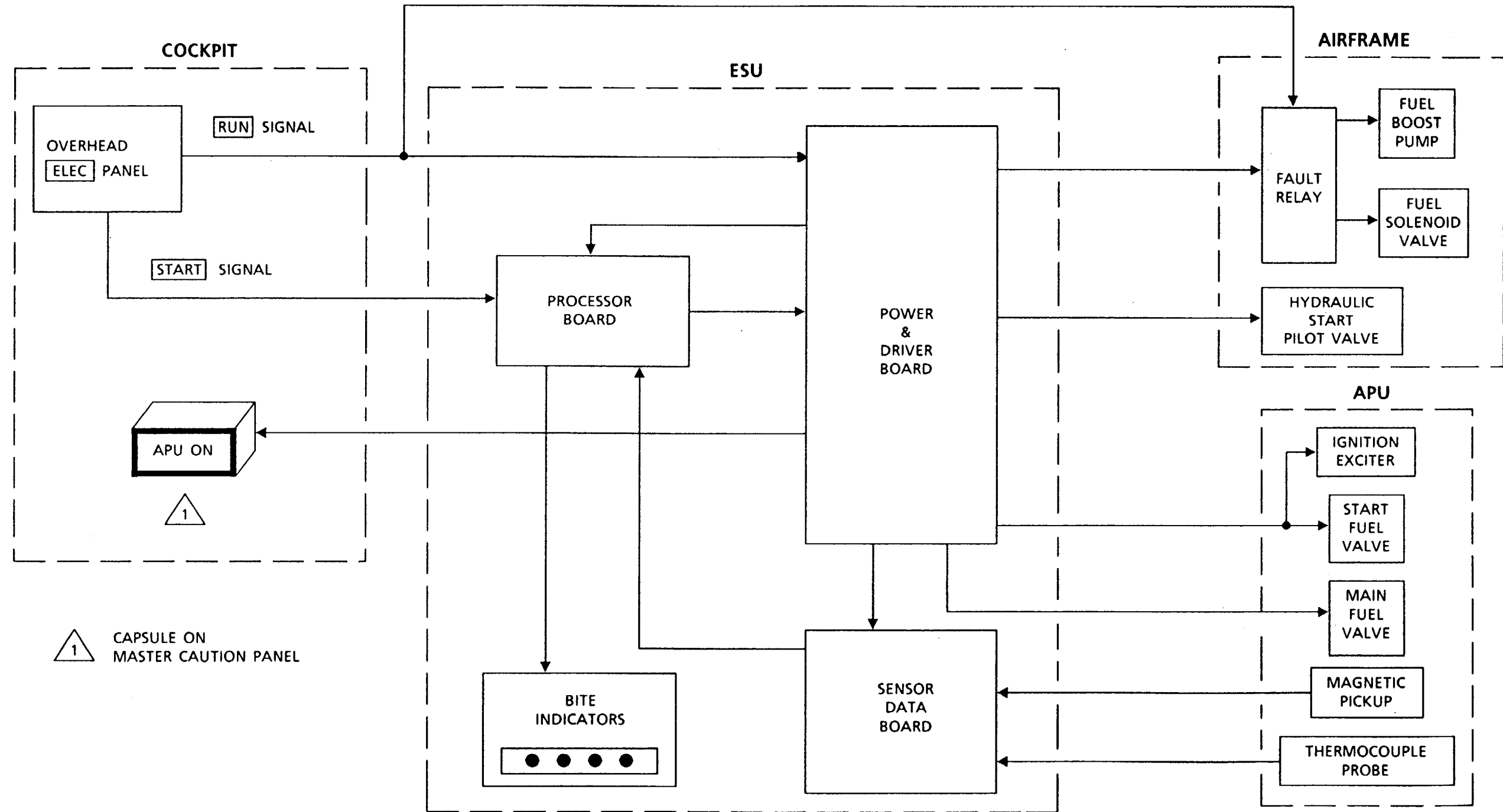

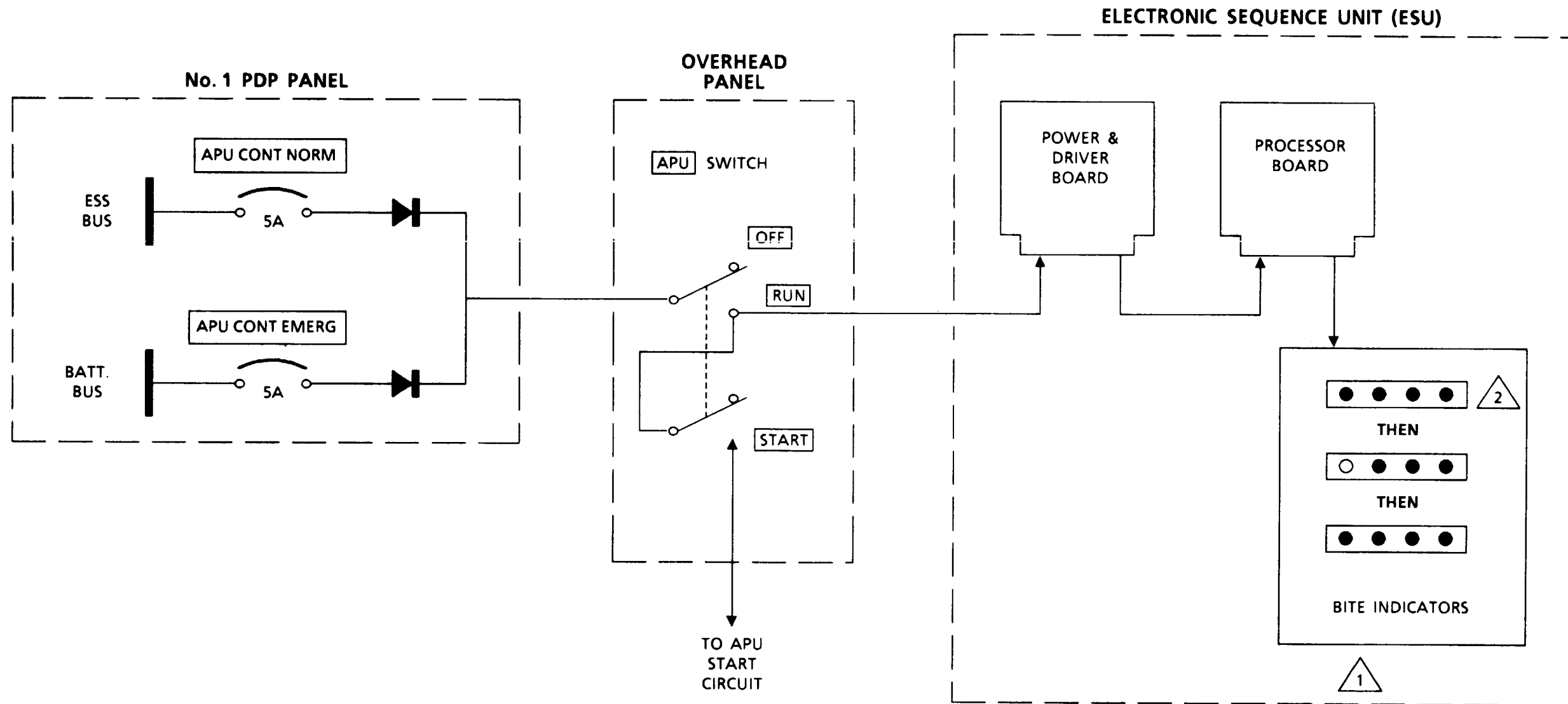

△ 1 NORMAL BITE SEQUENCE WHEN APU IS MOVED FROM OFF TO RUN.

△ 2 INITIAL INDICATION WILL SHOW A FAILURE CONDITION IF THE PREVIOUS APU SHUTDOWN WAS DUE TO A MALFUNCTION.

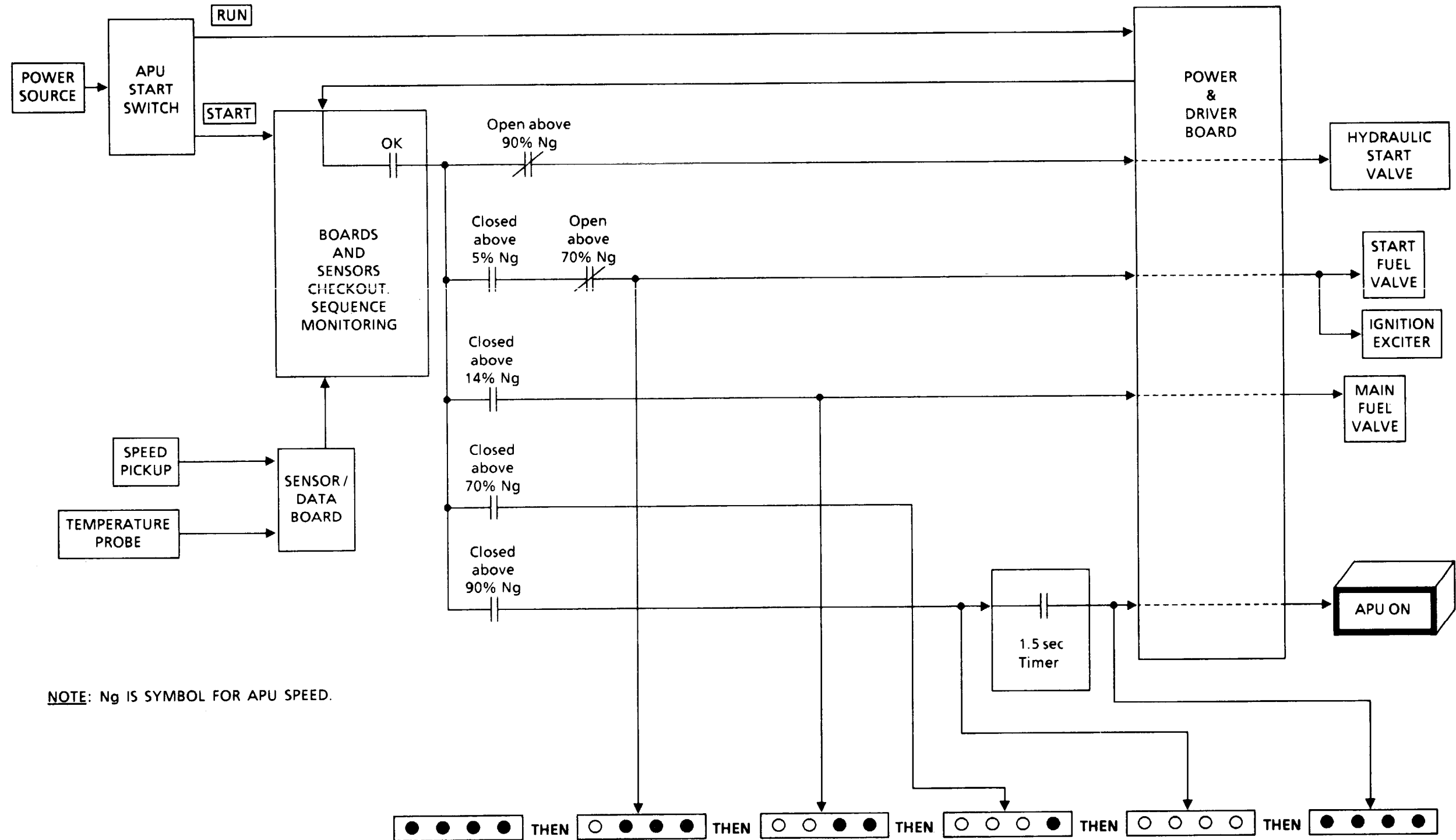

NOTE: Ng IS SYMBOL FOR APU SPEED.

15-6.9 MALFUNCTION BITE LOGIC BLOCK DIAGRAM (BEFORE START)

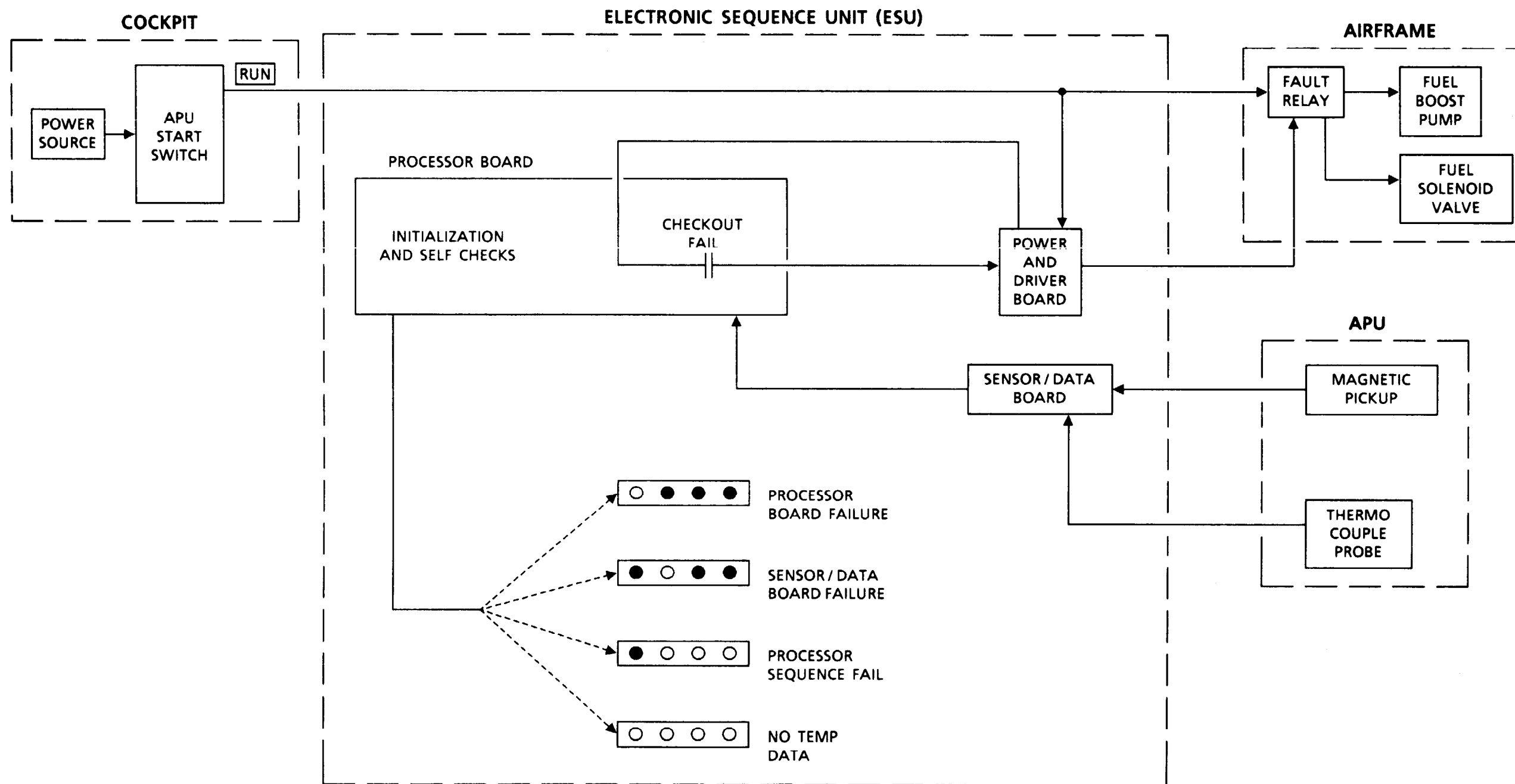

15-6.10 MALFUNCTION BITE LOGIC BLOCK DIAGRAM
(DURING STARTING AND RUNNING)

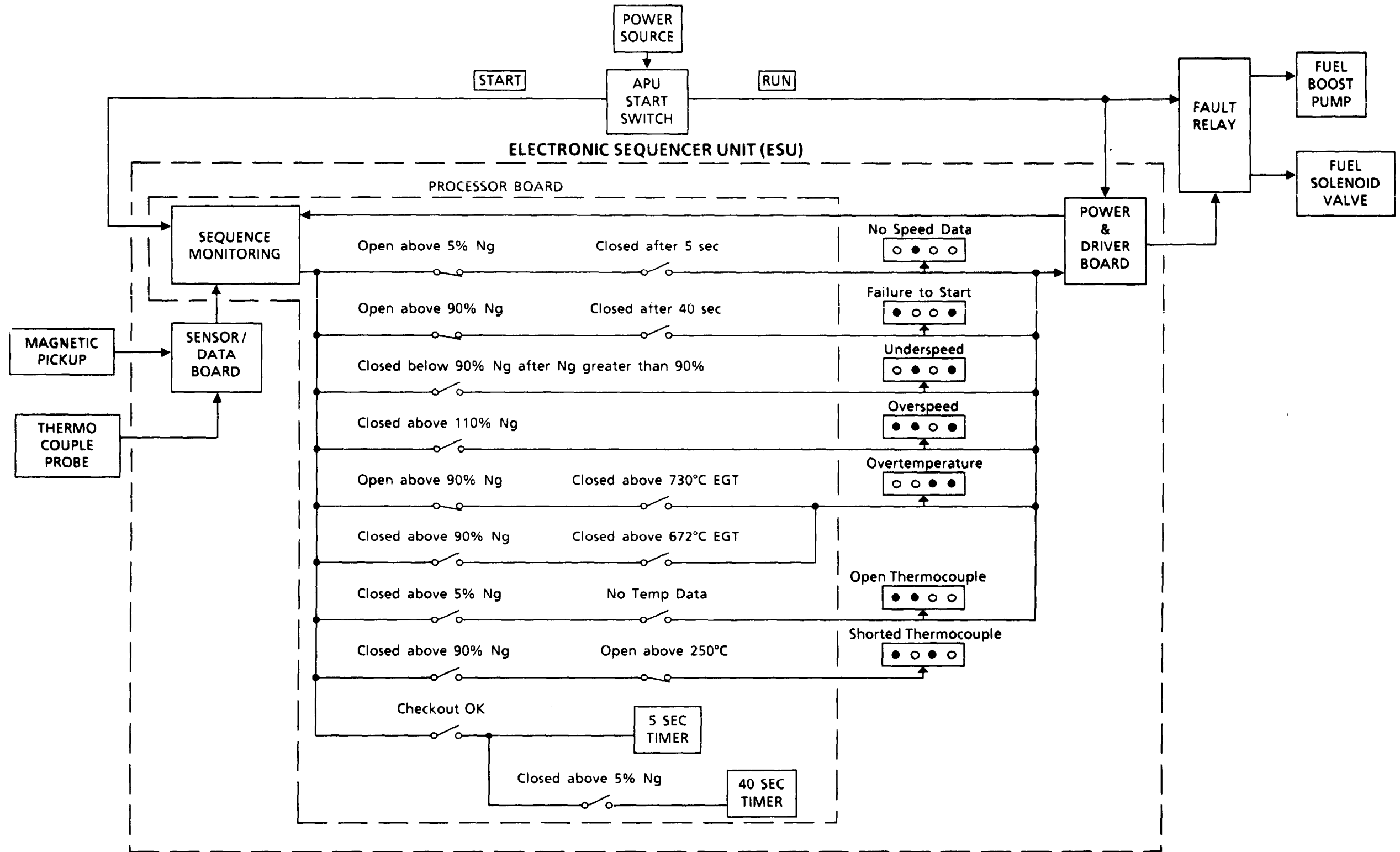

FAULT ISOLATION PROCEDURE

INITIAL SETUP

Applicable Configurations:
All

Tools:
Electrical Repairer's Tool Kit.
NSN 5180-00-329-4915
Multimeter

Materials:
None

Personnel Required:
Aircraft Electrician

References:
TM 55-1520-240-23

Equipment Condition:
TM 55-1520-240-23:
Battery Disconnected
Electrical Power Off
Hydraulic Power Off

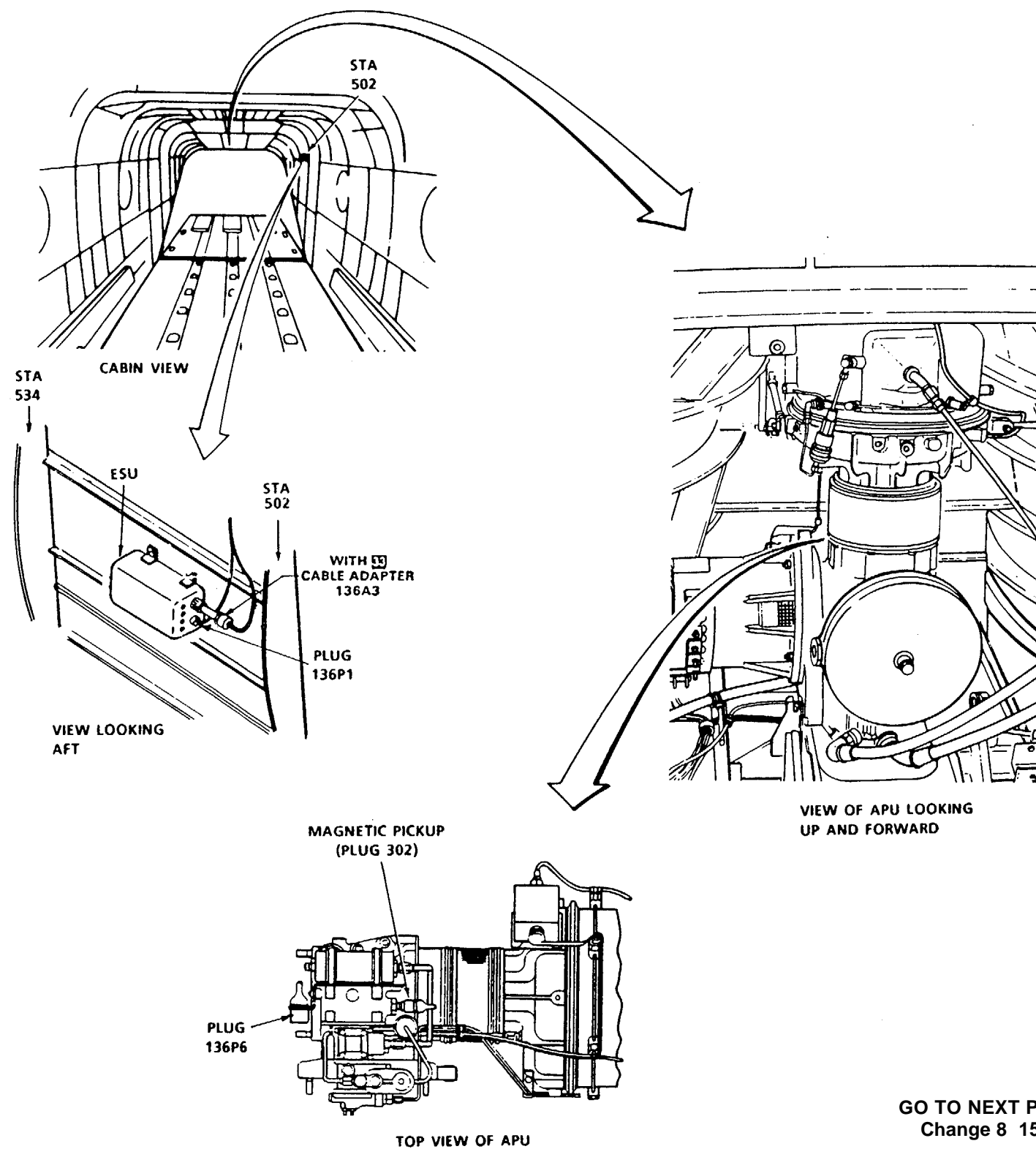

GO TO NEXT PAGE
Change 8 15-117

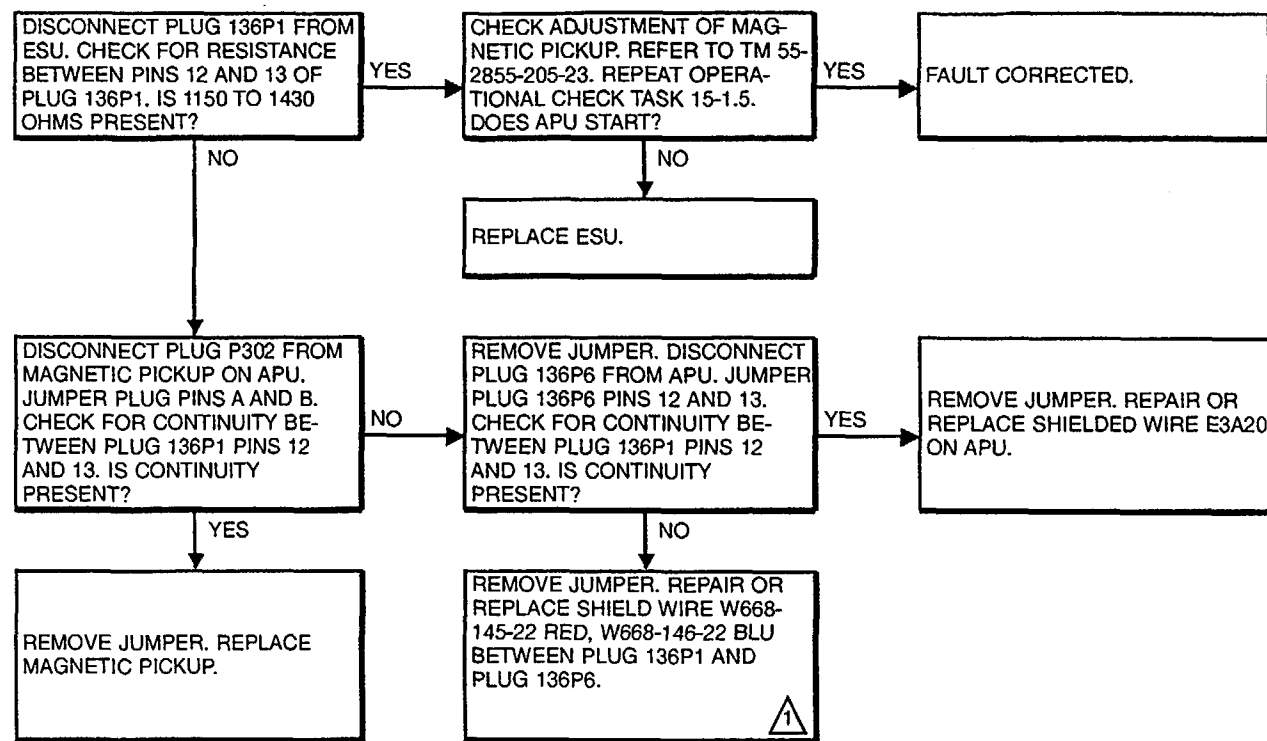

REFER TO WIRING DIAGRAM TASK 15-6.5 FOR FURTHER DETAILS.



FAULT ISOLATION PROCEDURE

INITIAL SETUP

Applicable Configurations:

All

Tools:

Aircraft Mechanic's Tool Kit,
NSN 5180-00-323-4692

Electrical Repairer's Tool Kit,
NSN 5180-00-323-4915

Multimeter
APU Tester 161226-200

Materials:

Cloth (E120)
Tape (E385)

Personnel Required:

Aircraft Electrician
Medium Helicopter Repairer

References:

TM 55-1520-240-23
TM 55-2835-205-23
TM 55-4920-431-13

Equipment Condition:

TM 55-1520-240-23

Battery Connected
Electrical Power On
Hydraulic Power Off

General Safety Instructions:

WARNING

All regulations and instructions for handling fuels shall be strictly observed.

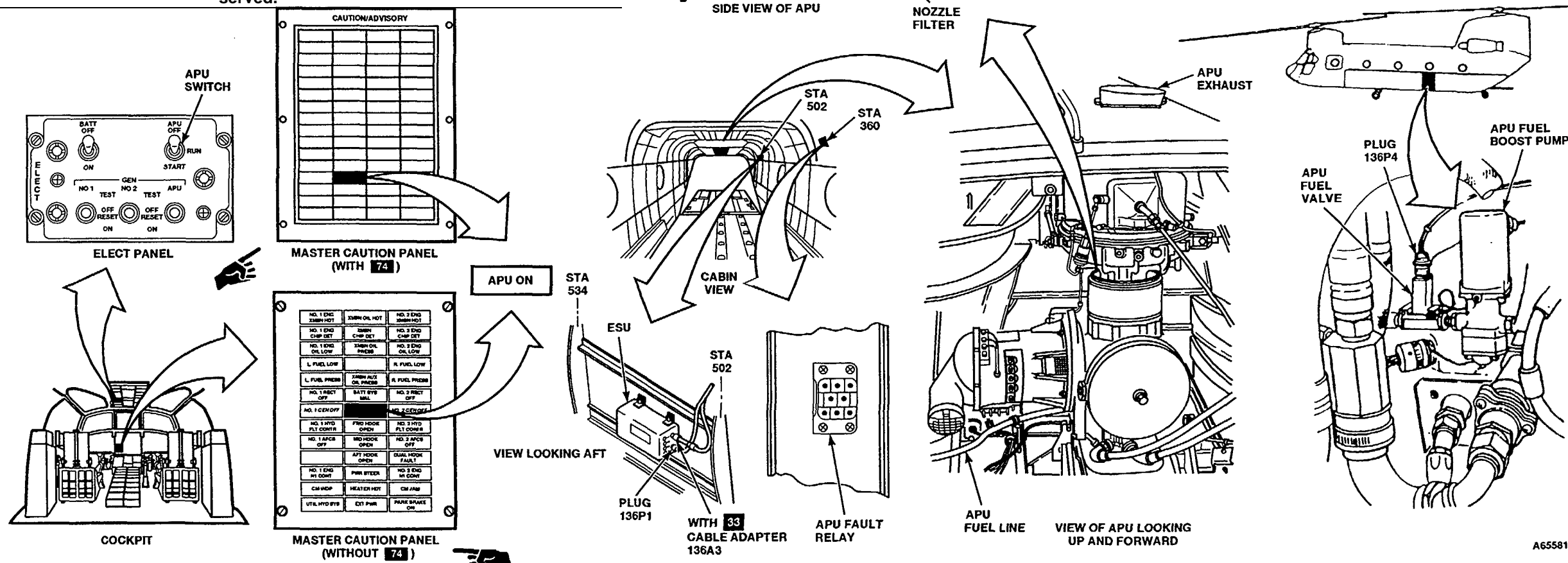
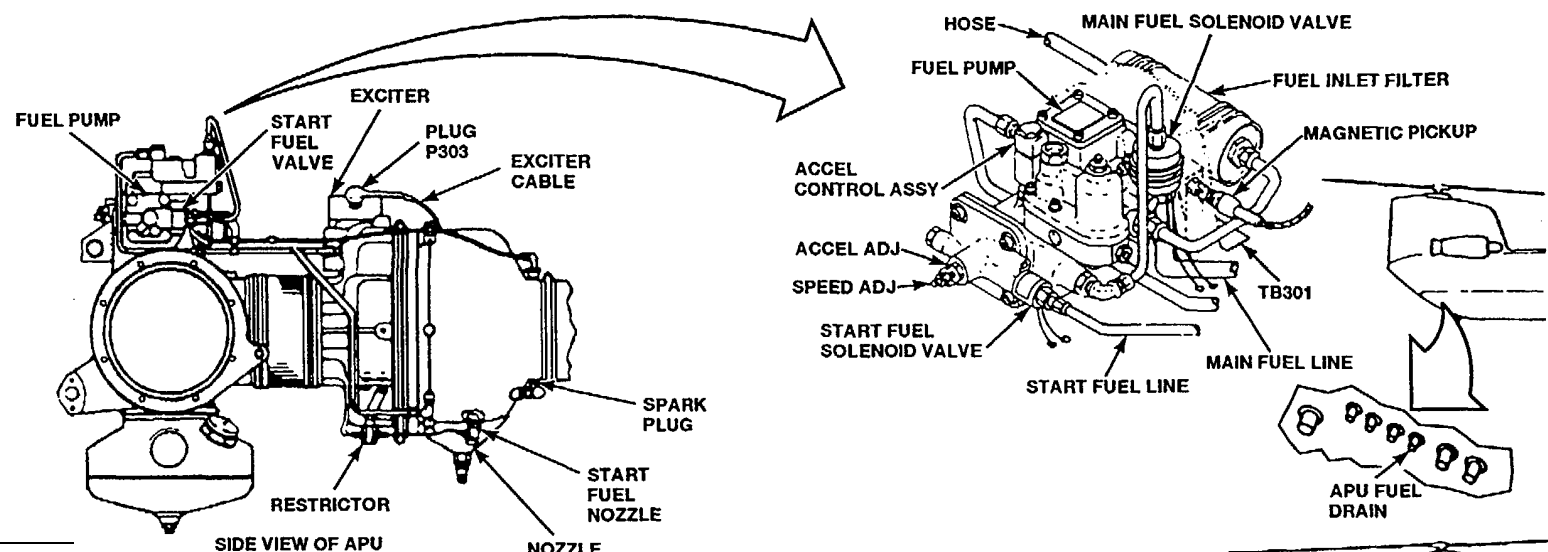

A65581

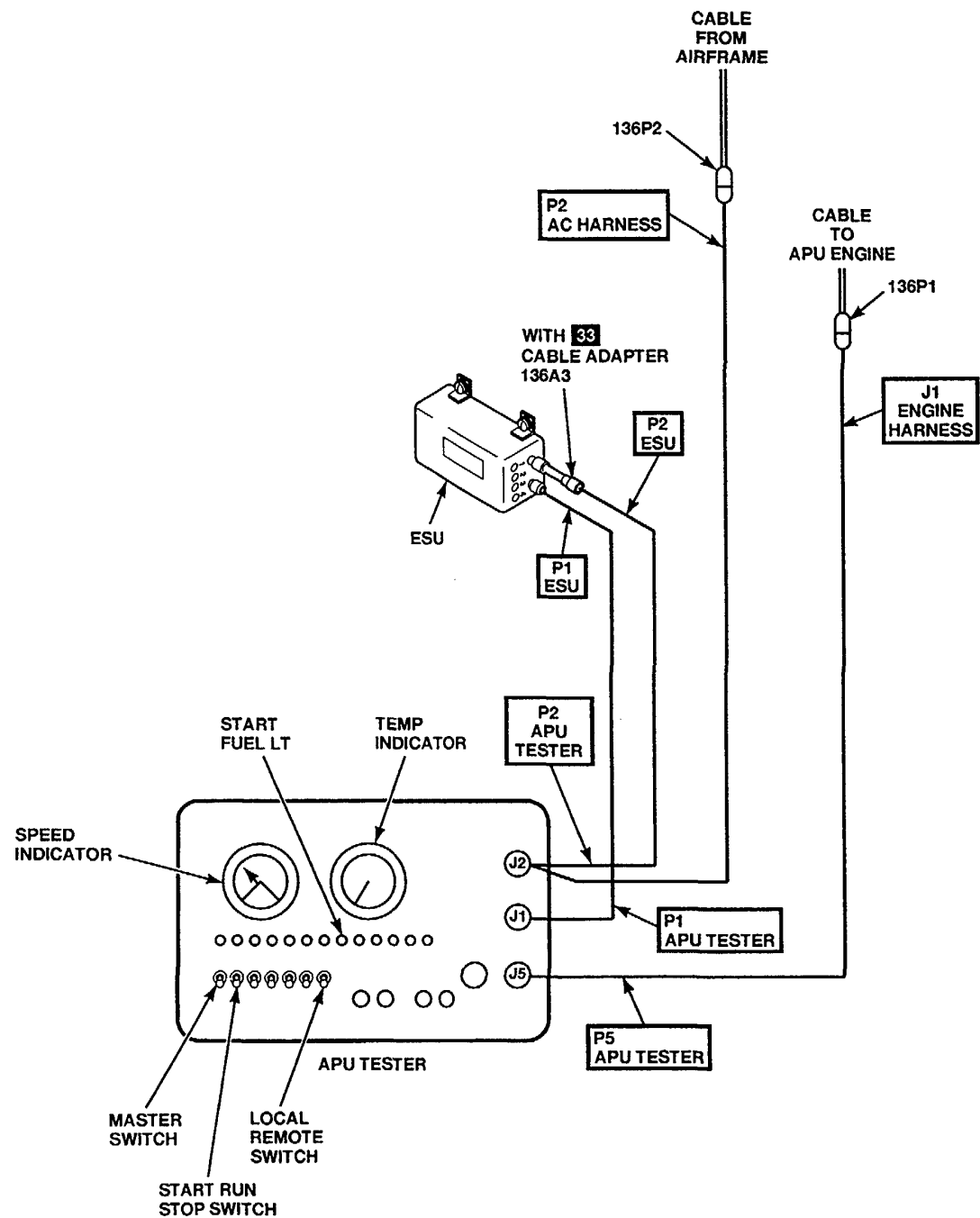

```

    graph TD
      Start[SET APU SW TO OFF. CONNECT APU TESTER BETWEEN ESU AND AIRFRAME WIRING. SET ALL TESTER SWITCHES DOWN. SET APU SW TO RUN. SET APU TESTER MASTER AND LOCAL/REMOTE SWITCHES UP. WATCH TESTER SPEED INDICATOR AND MAIN FUEL AND OIL PRESSURE LIGHTS. SET TESTER START/RUN STOP SW UP. IS SPEED INDICATOR READING ABOVE 15%?] -- NO --> Ref1[REFER TO APU HYDRAULIC TROUBLESHOOTING TASK 15-4.8.]
      Start -- YES --> CheckVapor[CHECK APU EXHAUST FOR FUEL VAPOR AND APU FUEL OVERBOARD DRAIN FOR DRIPPING FUEL. IS EITHER SEEN?]
      CheckVapor -- YES --> Ref1
      CheckVapor -- NO --> Snap[STAND BENEATH APU. SET TESTER START/RUN STOP SW DOWN AND THEN UP. CAN APU IGNITION BE HEARD SNAPPING?]
      Snap -- YES --> Filter[SET APU SW TO OFF. LOOSEN NUT ON OUTPUT LINE OF FUEL INLET FILTER. PLACE CLOTH AROUND NUT. SET APU SW TO RUN. DOES CLOTH GET DAMP WITH FUEL RAPIDLY?]
      Filter -- YES --> Ref1
      Filter -- NO --> Tighten[SET APU SW TO OFF. TIGHTEN NUT. HOLD FLEXIBLE APU FUEL LINE TO APU. CYCLE APU SW FROM OFF TO RUN TO OFF. IS SURGE FELT ON FUEL LINE?]
      Tighten -- YES --> ReplaceFilter[REPLACE APU FUEL INLET FILTER.]
      Tighten -- NO --> Valve[OPEN LEFT AFT INTERTANK BAY ACCESS COVER. HOLD BODY OF APU FUEL VALVE. CYCLE APU SW FROM OFF TO RUN TO OFF. DOES VALVE FEEL LIKE IT IS OPERATING?]
      Valve -- YES --> ReplacePump[REPLACE APU FUEL BOOST PUMP.]
      Valve -- NO --> Ground1[LOCATE OPEN IN WIRE W668-147-22 OR P2A20 BETWEEN PLUG 136P1 AND APU TB301-3. REPAIR OR REPLACE WIRE AS REQUIRED.]
      Snap -- NO --> Accum[SET TESTER START/RUN STOP SW DOWN. CHECK THAT ACCUMULATOR IS CHARGED. WATCH TESTER SPEED INDICATOR AND START FUEL LT. SET TESTER START/RUN STOP SW UP. DOES START FUEL LT COME ON WHEN SPEED INDICATOR READING PASSES 5%?]
      Accum -- YES --> Ground2[SET TESTER SWITCHES DOWN AND DISCONNECT TESTER. CHECK FOR GROUND ON PLUG 136P1 PIN 10. IS GROUND PRESENT?]
      Ground2 -- YES --> Ground1
      Ground2 -- NO --> Ground3[LOCATE OPEN IN APU GROUND WIRE P1H16N BETWEEN TB301-4 ON APU AND APU FRAME. REPAIR OR REPLACE WIRE AS REQUIRED.]
      Accum -- NO --> ESU[SET TESTER SWITCHES DOWN AND DISCONNECT TESTER. REPLACE ESU.]
  
```

A72526

⚠ REFER TO WIRING DIAGRAM 15-6.5 FOR FURTHER DETAILS.

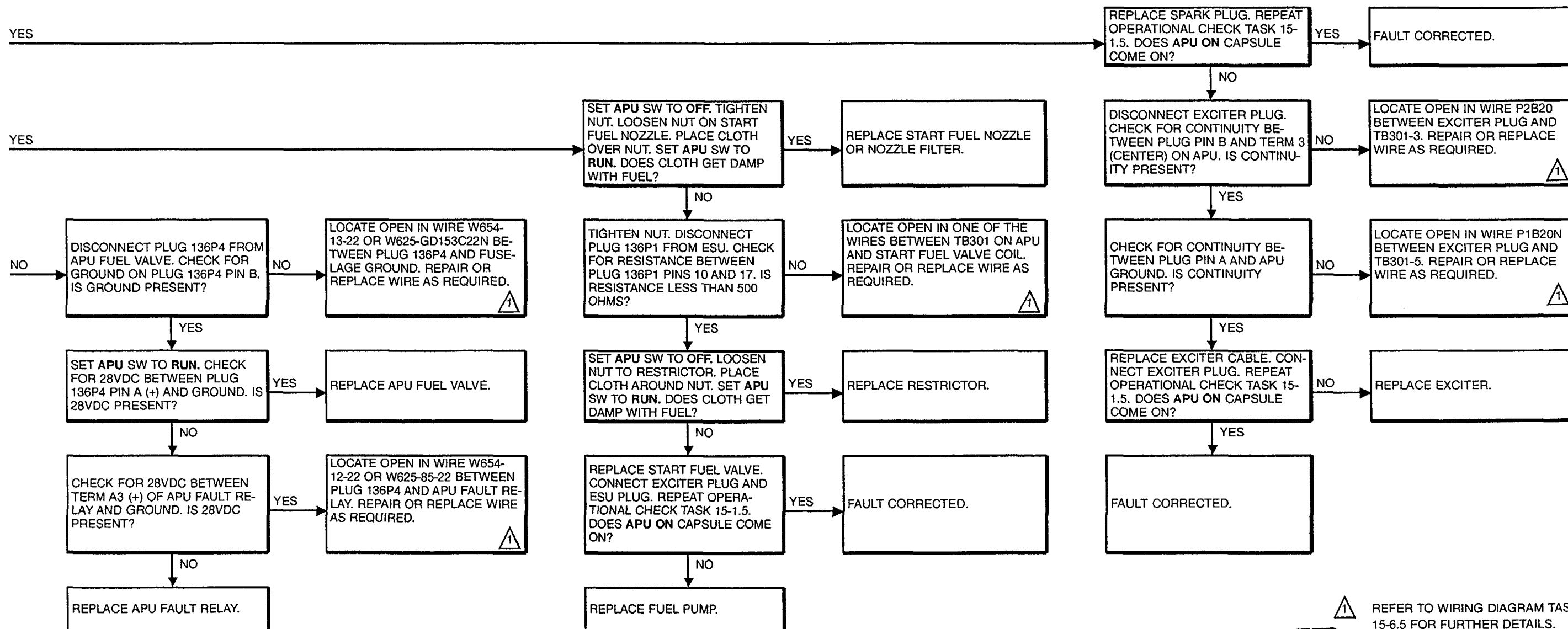

15-6.12 APU MOTORS BUT DOES NOT START, ESU BITE INDICATES ○●●● OR ○○●● THEN ●○○● (FAILURE TO START) (Continued)

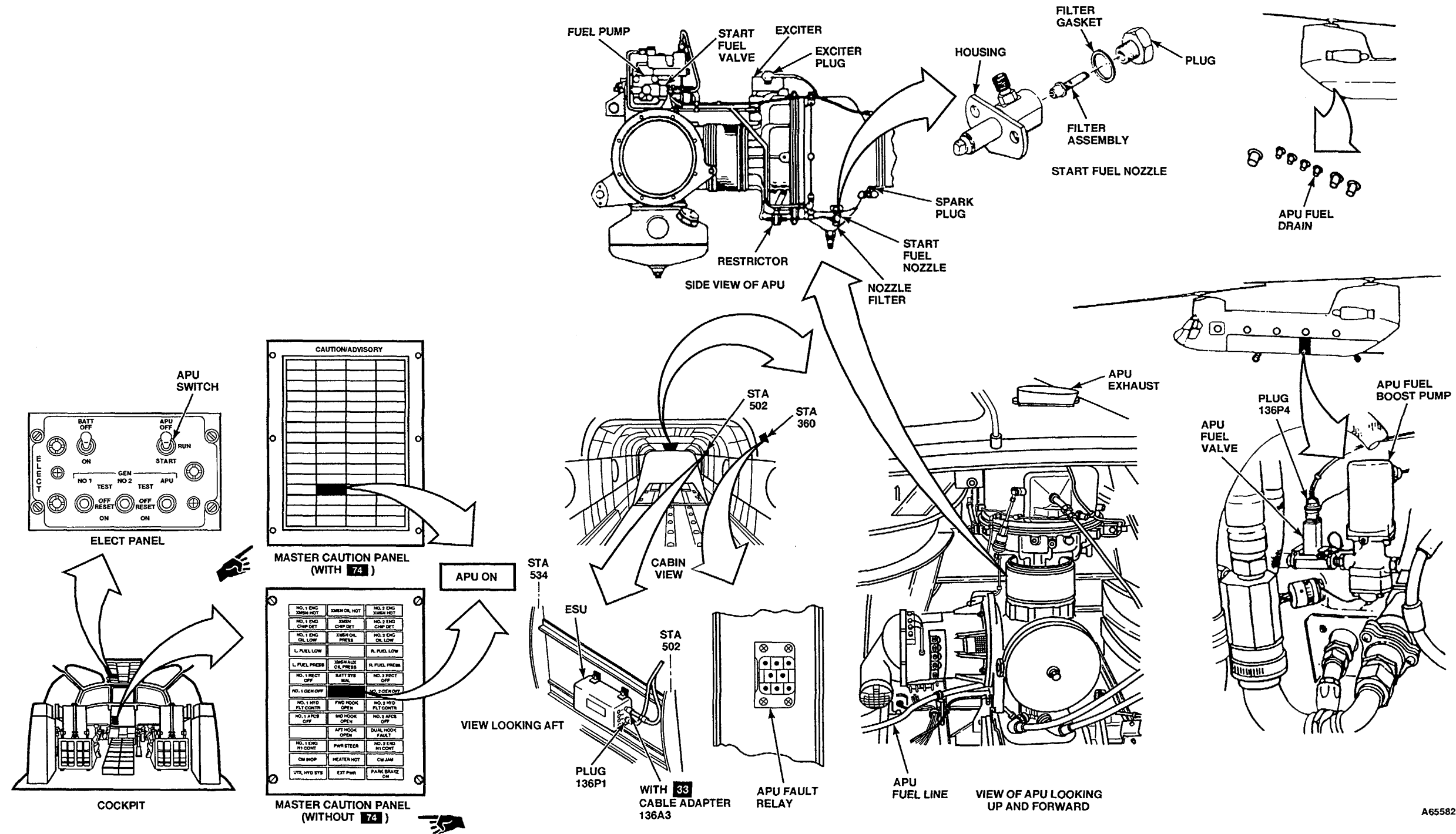

A65582

FAULT ISOLATION PROCEDURE

INITIAL SETUP

Applicable Configurations
All I

Tools:

- Aircraft Mechanic's Tool Kit, NSN 5180-00-323-4692
- Electrical Repairer's Tool Kit, NSN 5180-00-323-4915
- Multimeter
- APU Tester 161226-200

Materials:

None I

Personnel Required:

- Aircraft Electrician
- Medium Helicopter Repairer

References:

- TM 55-1520-240-23
- TM 55-2835-203-23
- TM 55-2835-203-23
- TM 55-1500-343-23
- TM 55-4920-431-13

Equipment Condition:

- TM 55-1520-240-23
- Battery Connected
- Electrical Power On
- Hydraulic Power Off

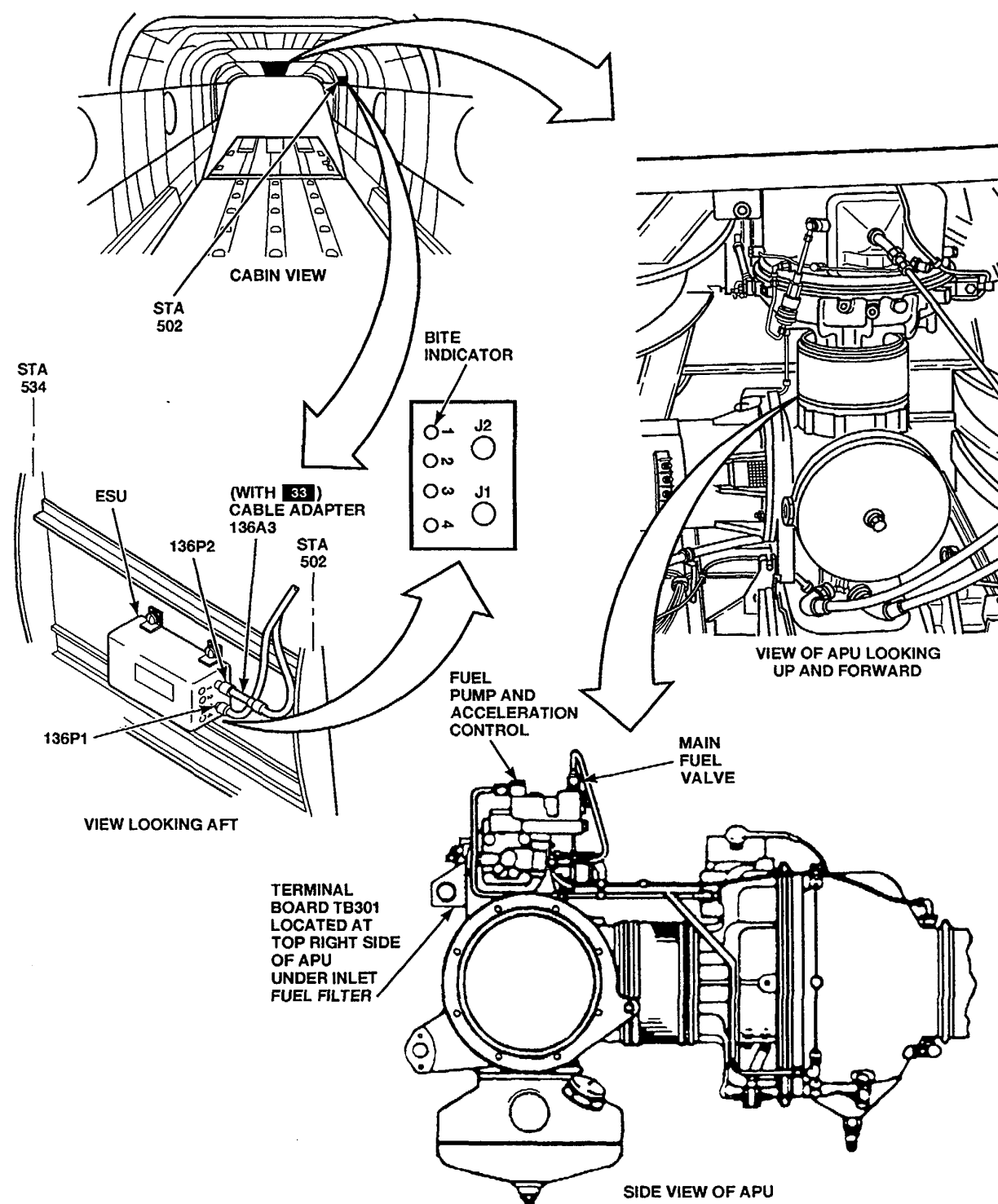
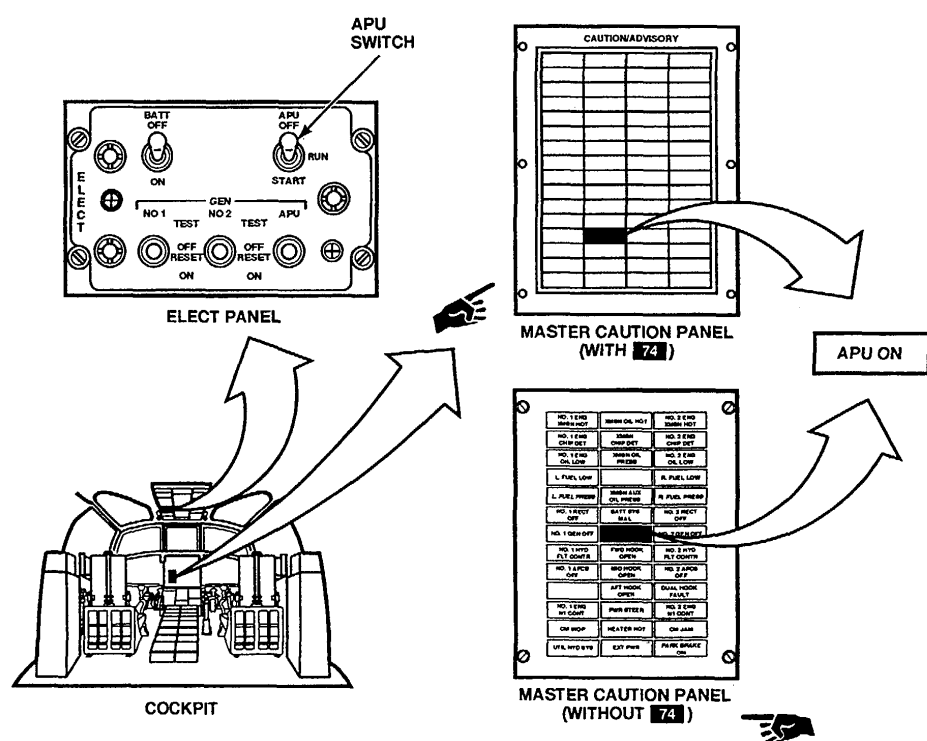

A65584

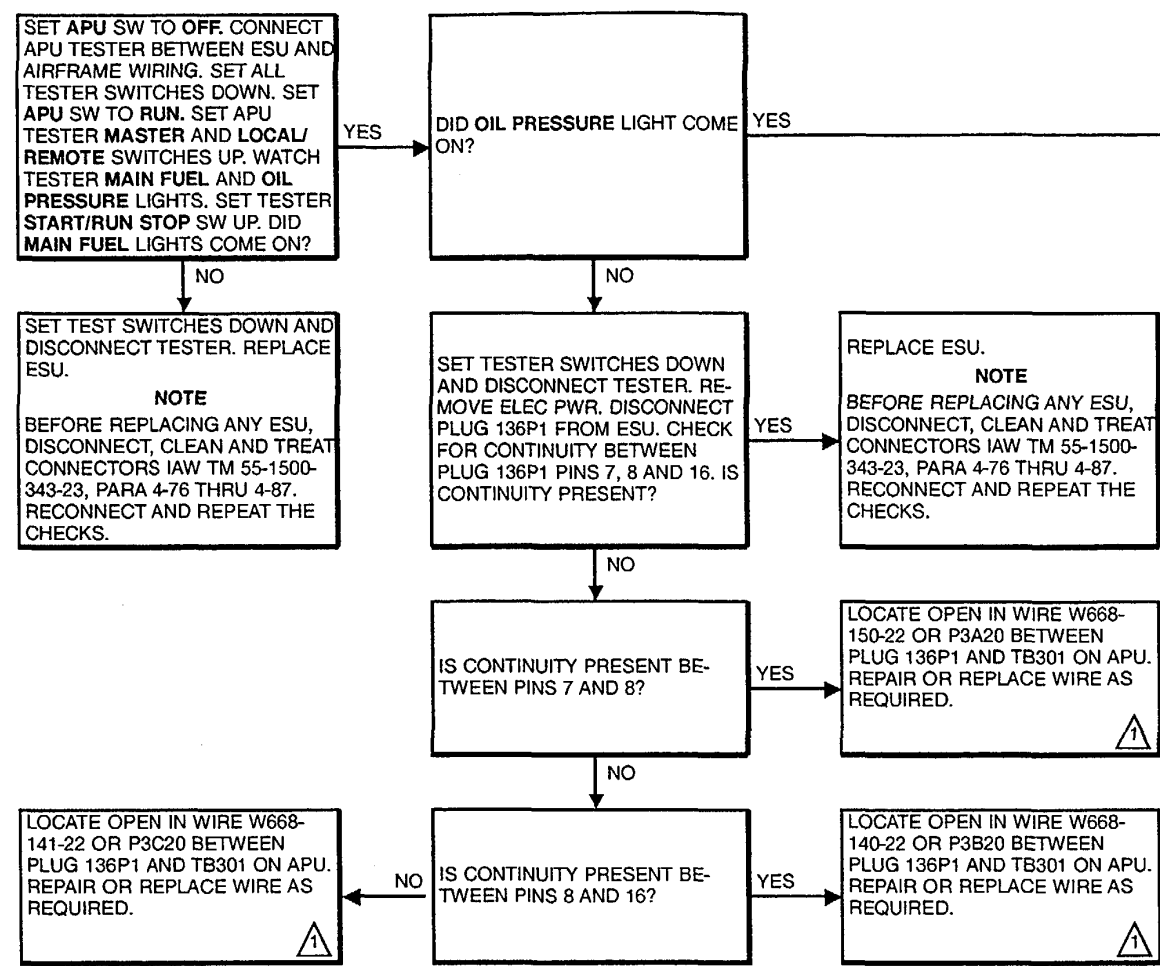

⚠ REFER TO WIRING DIAGRAM IN TASK 15-6.5 FOR FURTHER DETAILS.

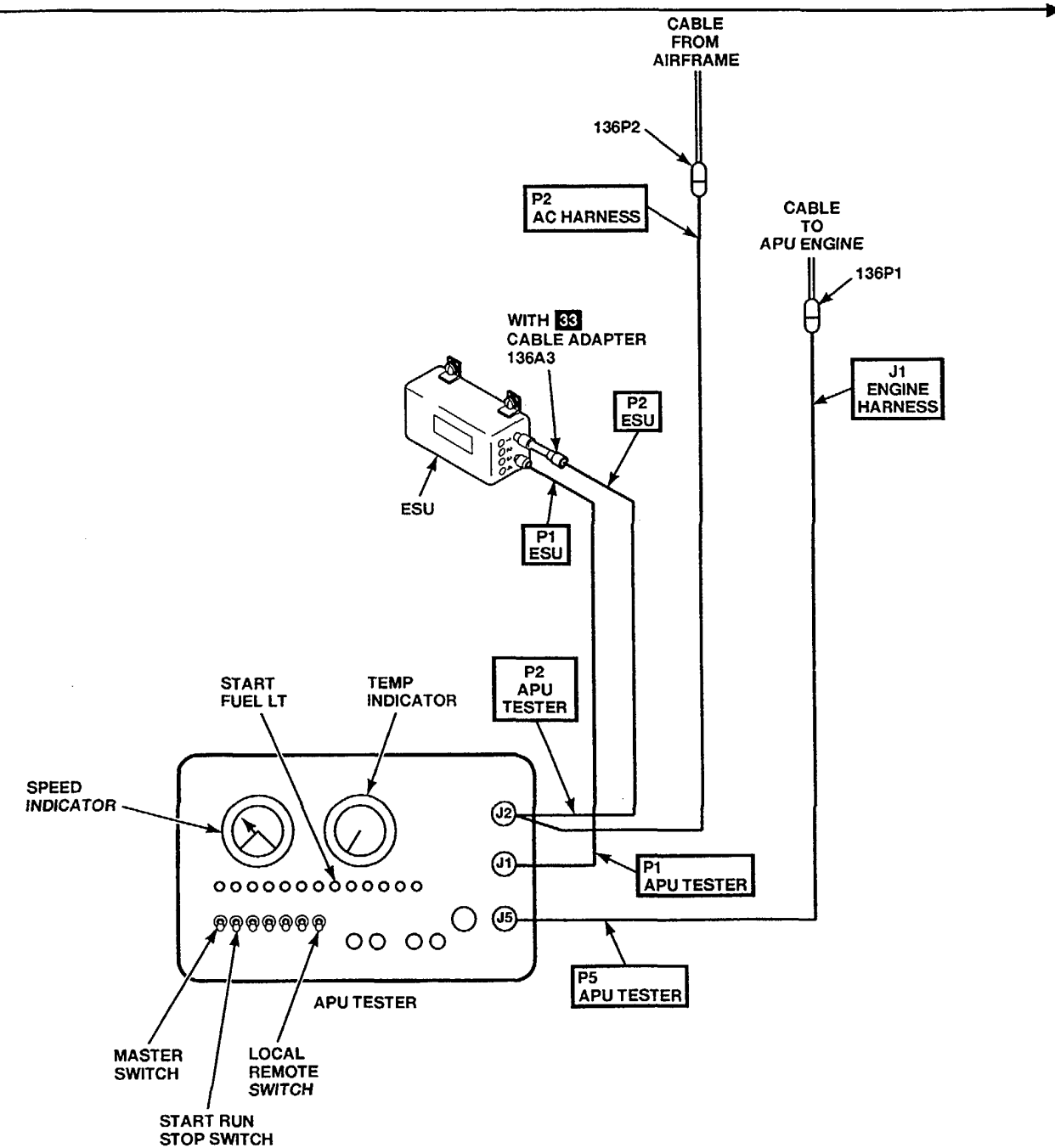

A72526

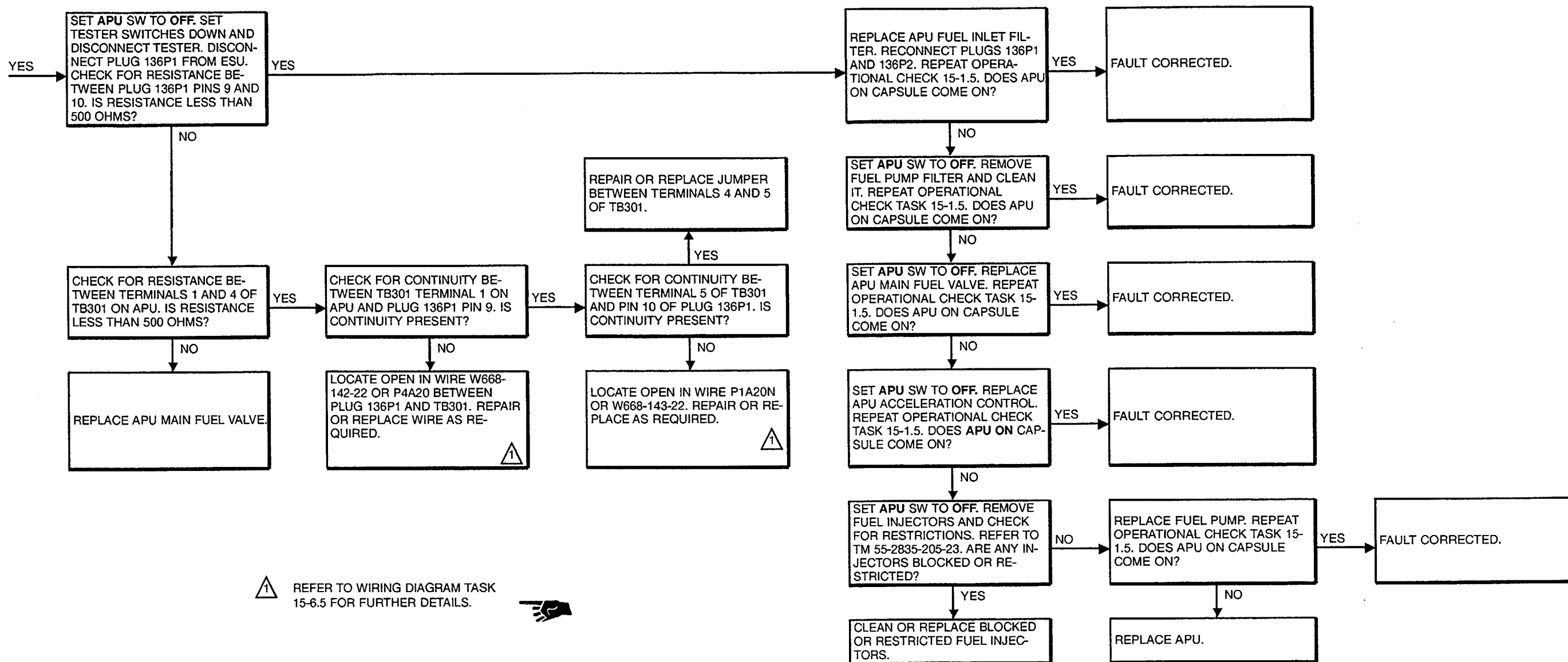

⚠ REFER TO WIRING DIAGRAM TASK 15-6.5 FOR FURTHER DETAILS.

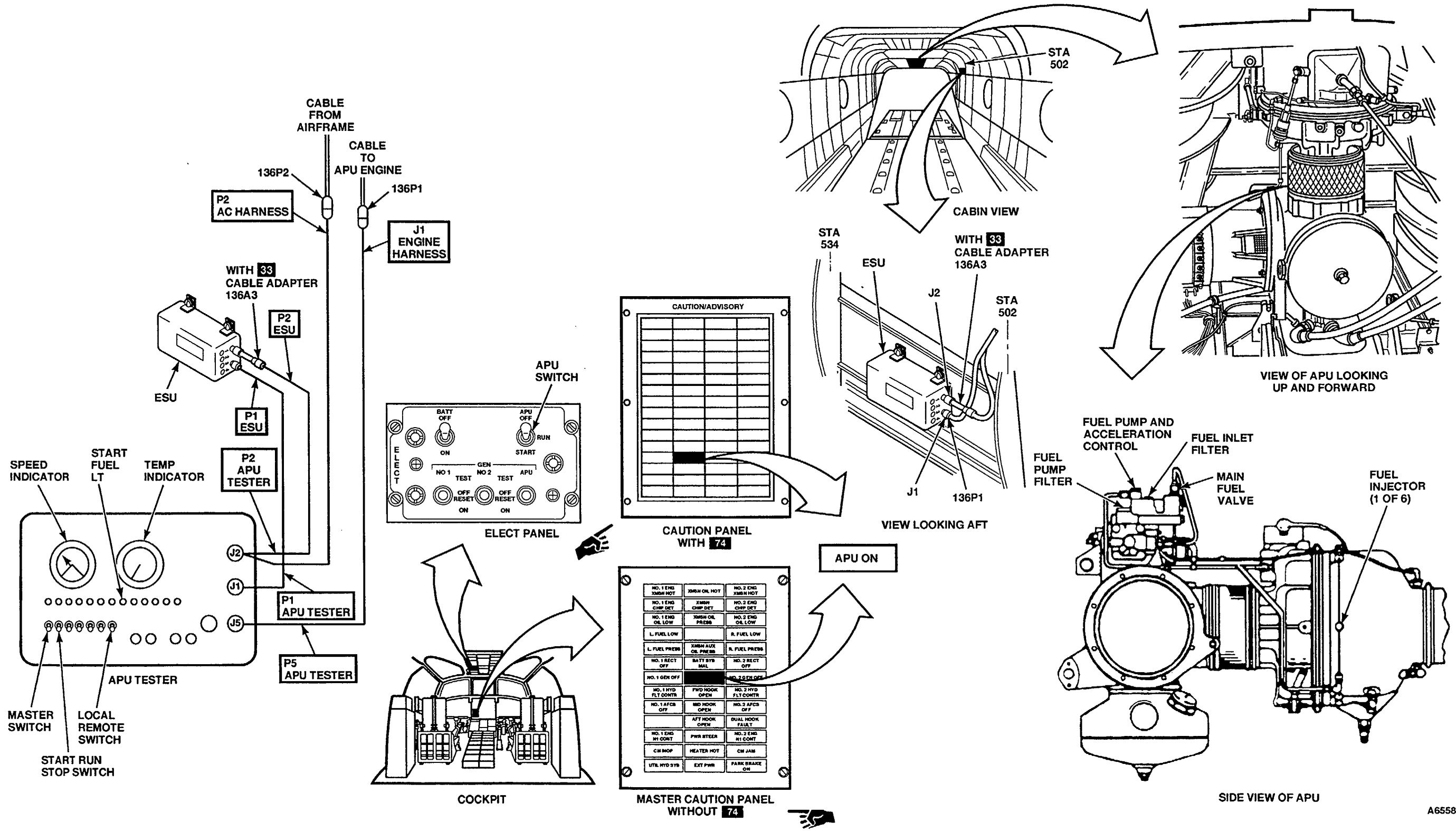

15-6.14 APU STARTS BUT SHUTS DOWN, ESU BITE INDICATES ●●○○ (OVERSPEED)

FAULT ISOLATION PROCEDURE

INITIAL SETUP

Applicable Configurations:
All

Tools:

- Aircraft Mechanic's Tool Kit,
NSN 5180-00-323-4692
- Electrical Repairer's Tool Kit,
NSN 5180-00-323-4915
- APU Tester 161226-200

Materials:
None

Personnel Required:
Aircraft Electrician
Medium Helicopter Repairer

References

- TM 55-1520-240-23
- TM 55-2835-203-23
- TM 55-4920-431-13

Equipment Condition:

- TM 55-1520-240-23
- Battery Connected
- Electrical Power On
- Hydraulic Power On
- APU Tester Connected Between ESU and Airframe
- Wiring. All Tester Switches Set Down

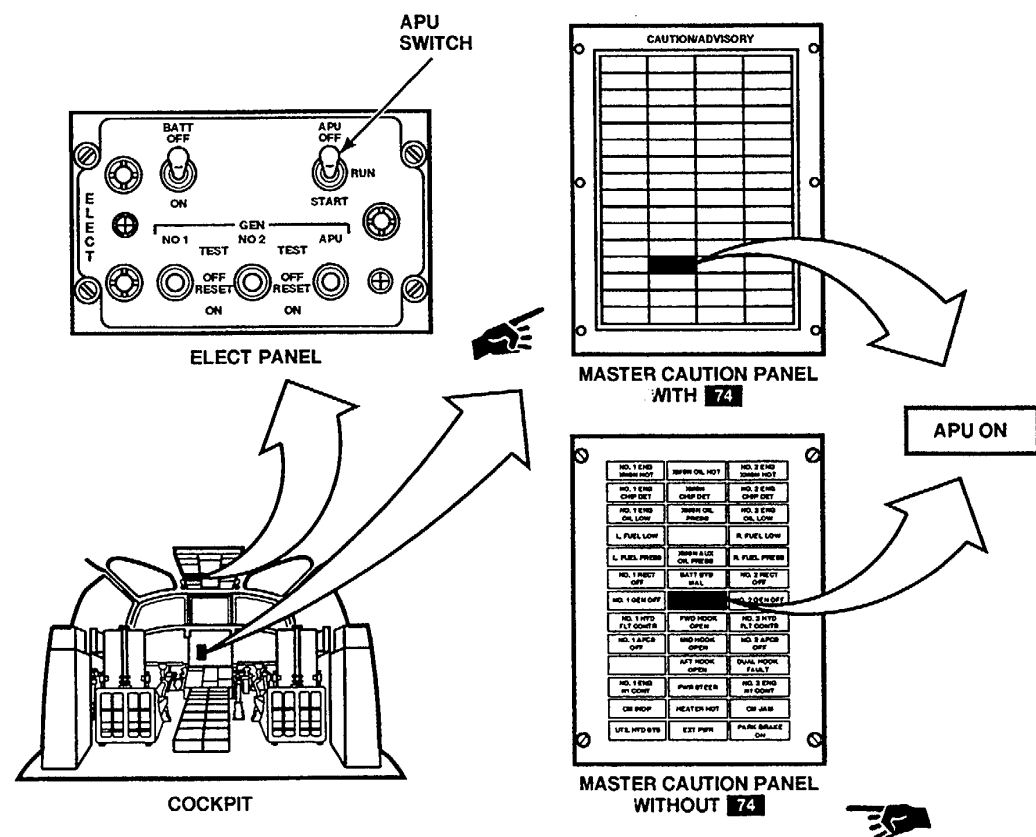
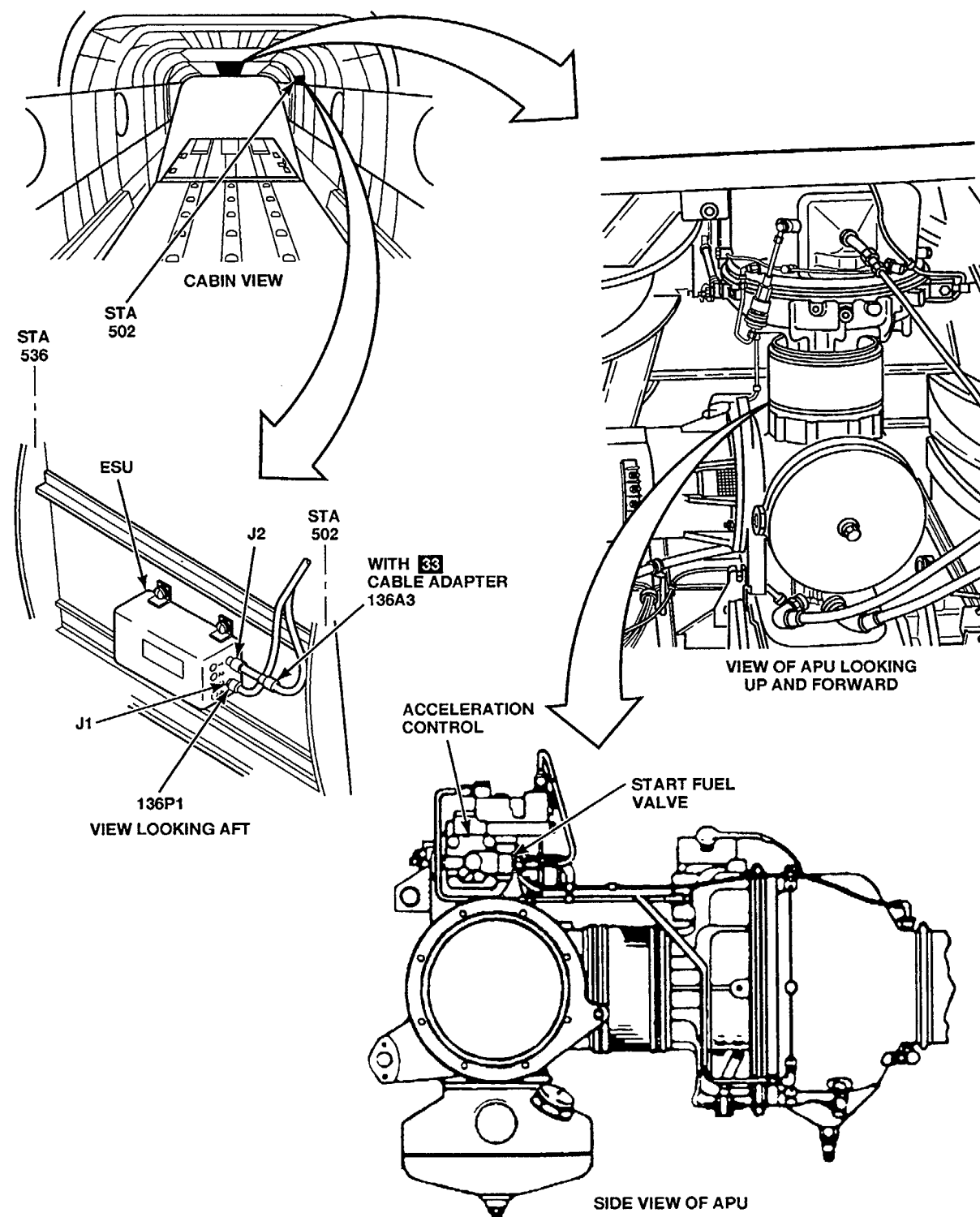

15-6.14 APU STARTS BUT SHUTS DOWN, ESU BITE INDICATES (OVERSPEED) (CONTINUED)

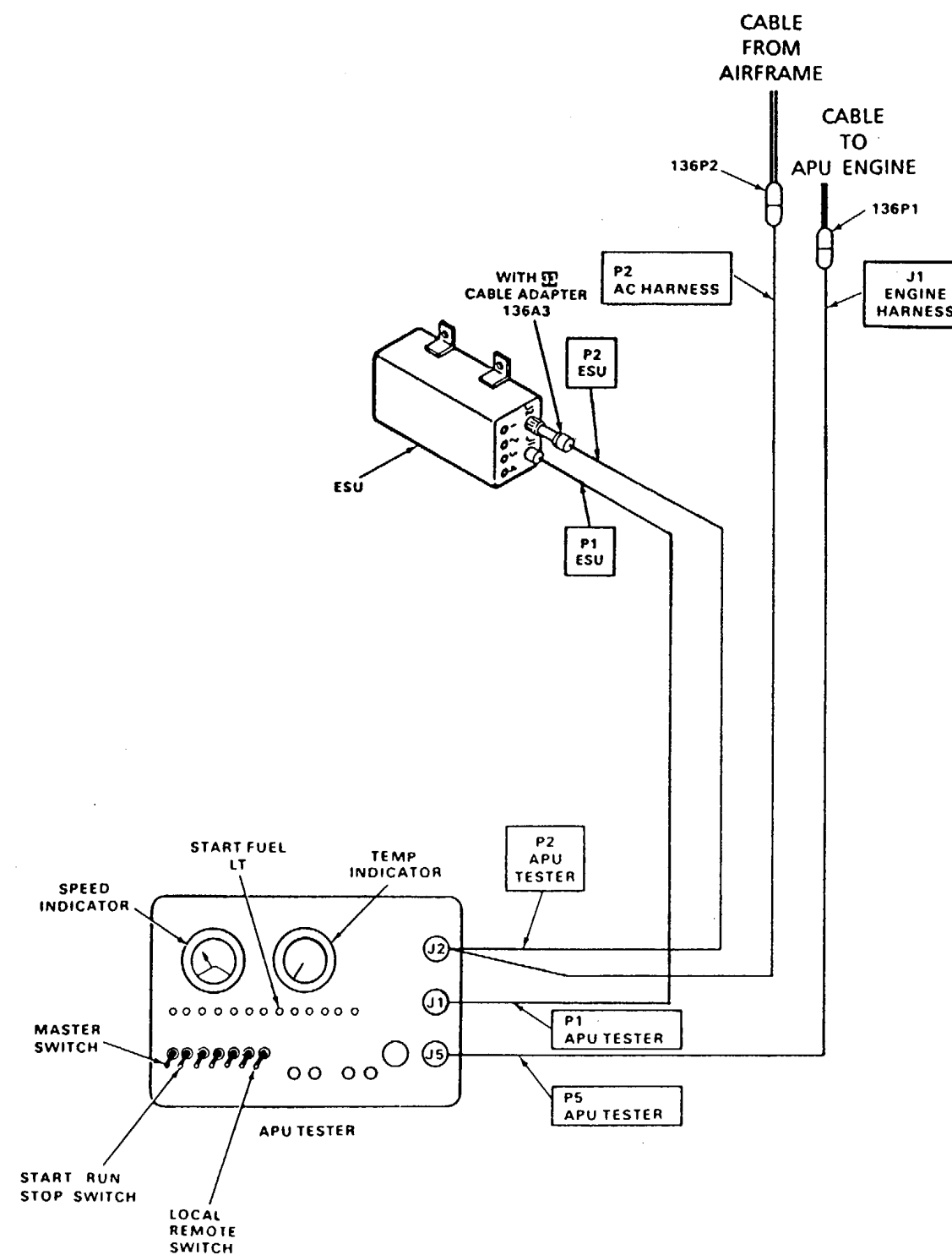
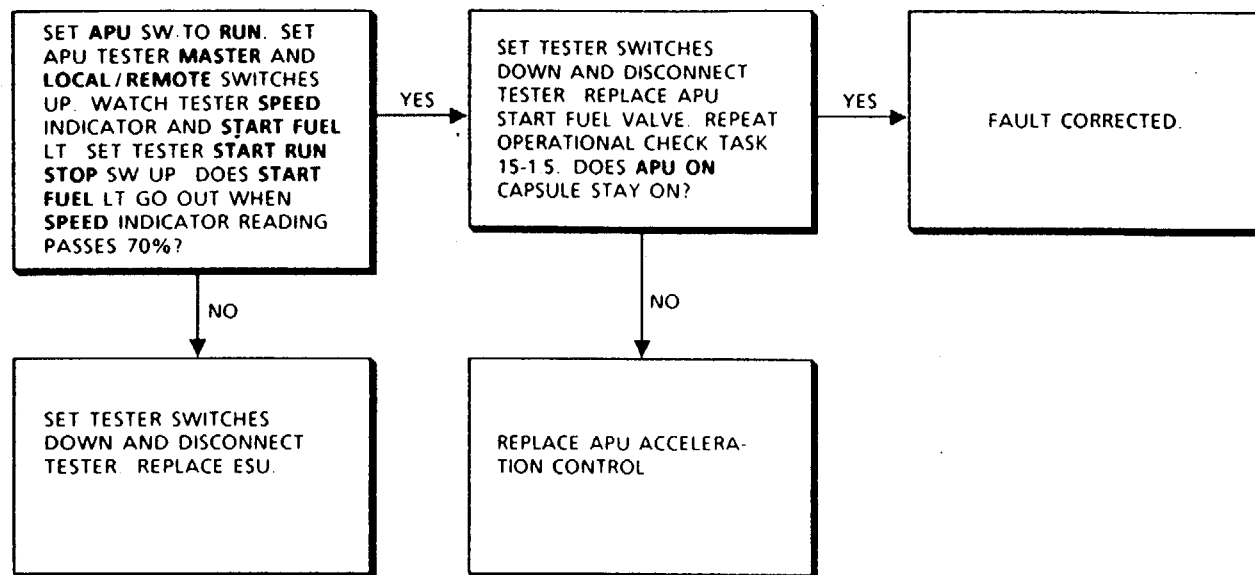

FAULT ISOLATION PROCEDURE

INITIAL SETUP

Applicable Configurations
All

Tools:
Aircraft Mechanic's Tool Kit,
NSN 5180-00-323-4692

Materials:
Cloth (E120)
Tape (E385)

Personnel Required:
Medium Helicopter Repairer (2)

References:
TM 55-1520-240-23
TM 55-2835-203-23

Equipment Condition:
TM 55-1520-240-23
Battery Connected
Electrical Power On
Hydraulic Power On

General Safety Instructions:

WARNING

All regulations and instructions for handling fuels shall be strictly observed

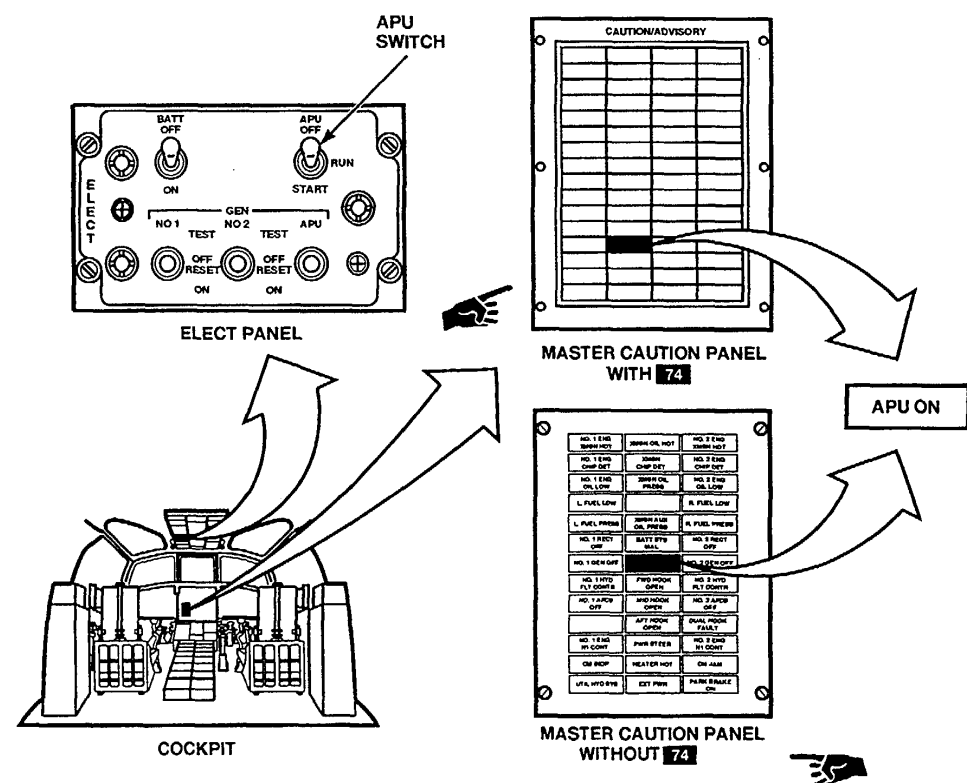
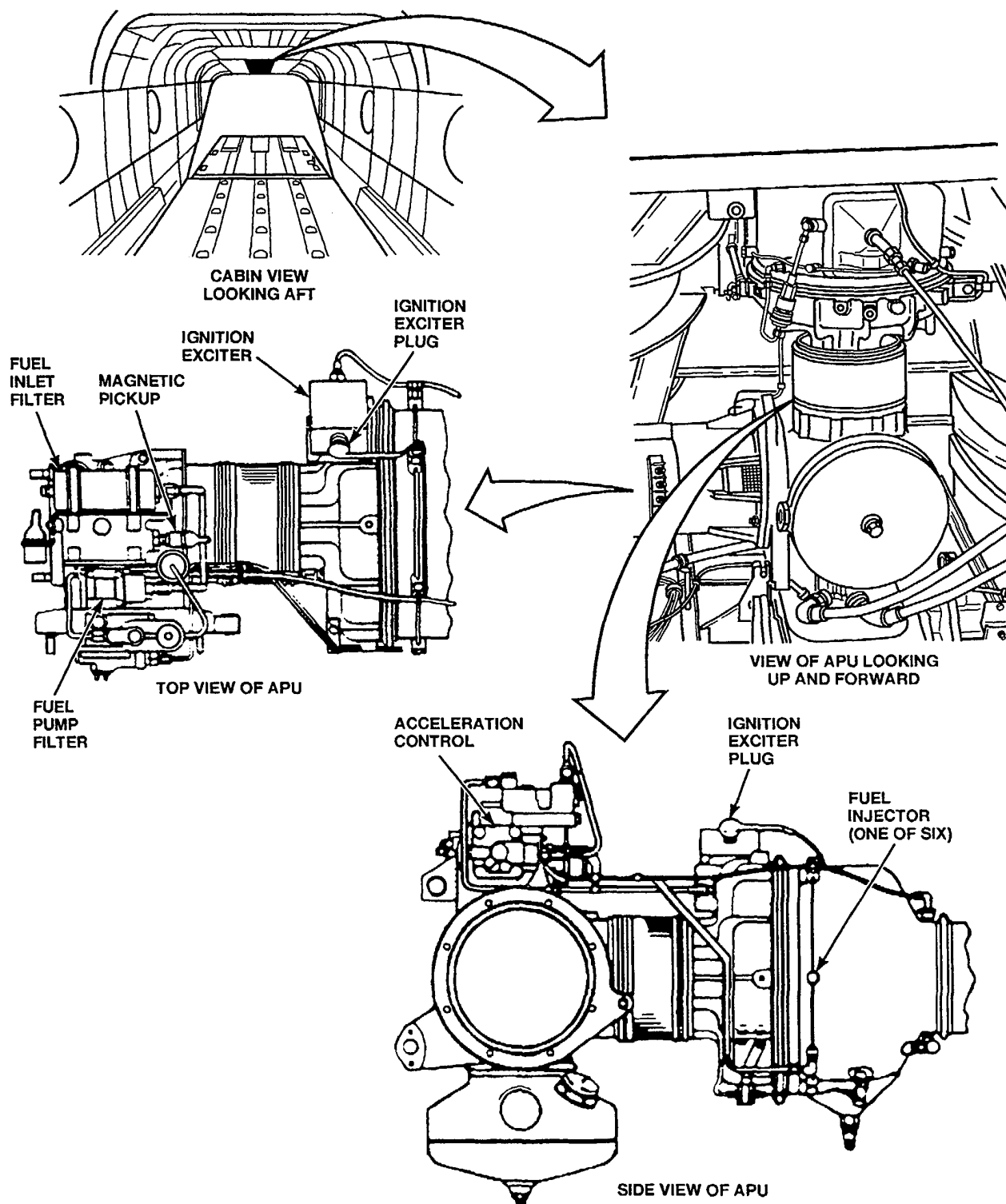

A65586

15-6.15 APU STARTS BUT SHUTS DOWN, ESU BITE INDICATES (UNDERSPEED) (CONTINUED) ○ ● ○ ●

15-6.15

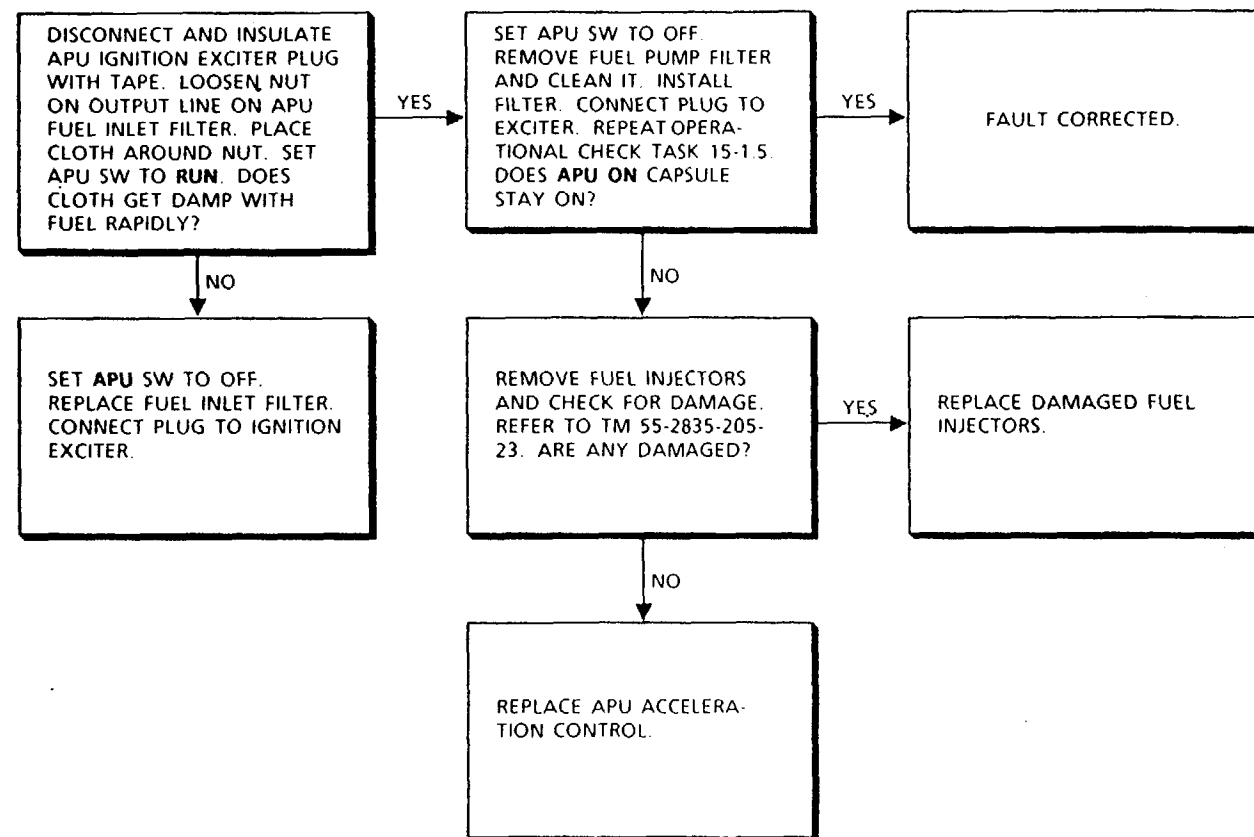

END OF TASK

FAULT ISOLATION PROCEDURE

INITIAL SETUP

Applicable Configurations

All

Tools

- Aircraft Mechanic's Tool Kit,
NSN 5180-00-323-4692
- Electrical Repairer's Tool Kit,
NSN 5180-00-323-4915
- APU Tester 161226-200

Materials

None

Personnel Required:

- Aircraft Electrician
- Medium Helicopter Repairer

References

- TM 55-1520-240-23
- TM 55-2835-203-23
- TM 55-1500-343-23
- TM 55-4920-431-13

Equipment Condition:

- TM 55-1520-240-23
- Battery Connected
- Electrical Power On
- Hydraulic Power On
- APU Tester Connected Between ESU and Airframe
- Wiring. All Tester Switches Set Down

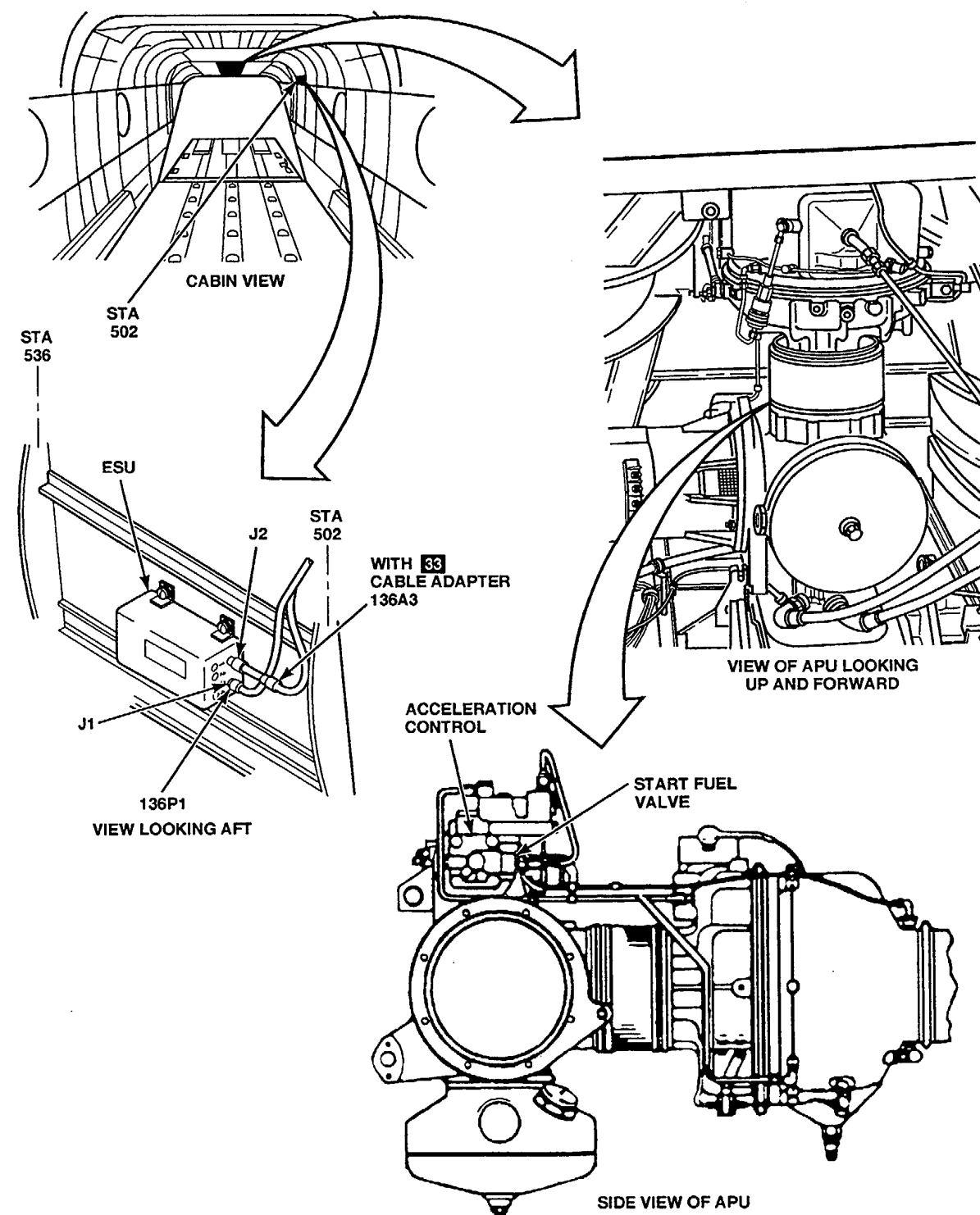
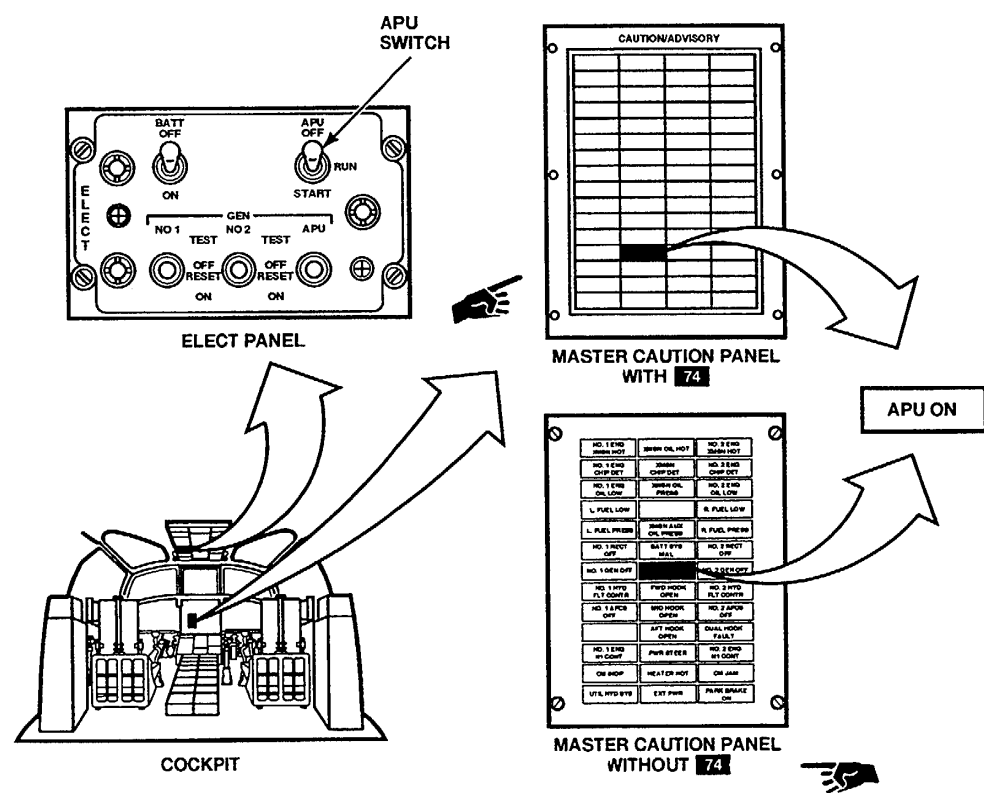

A65585

GO TO NEXT PAGE

Change 23 15-131

15-6.16 APU STARTS BUT SHUTS DOWN, ESU BITE INDICATES ○ ○ ● ● (OVERTEMPERATURE) (CONTINUED)

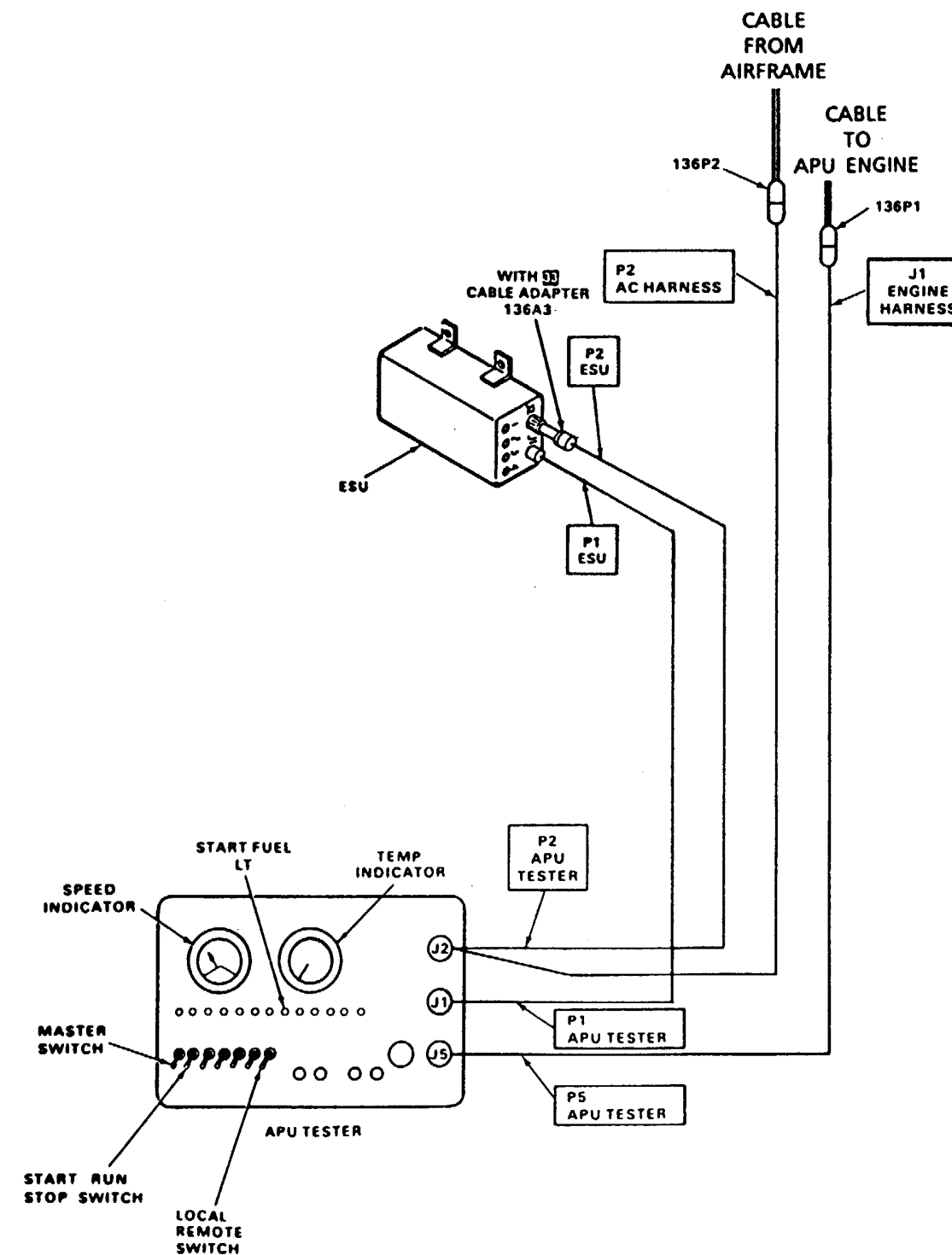
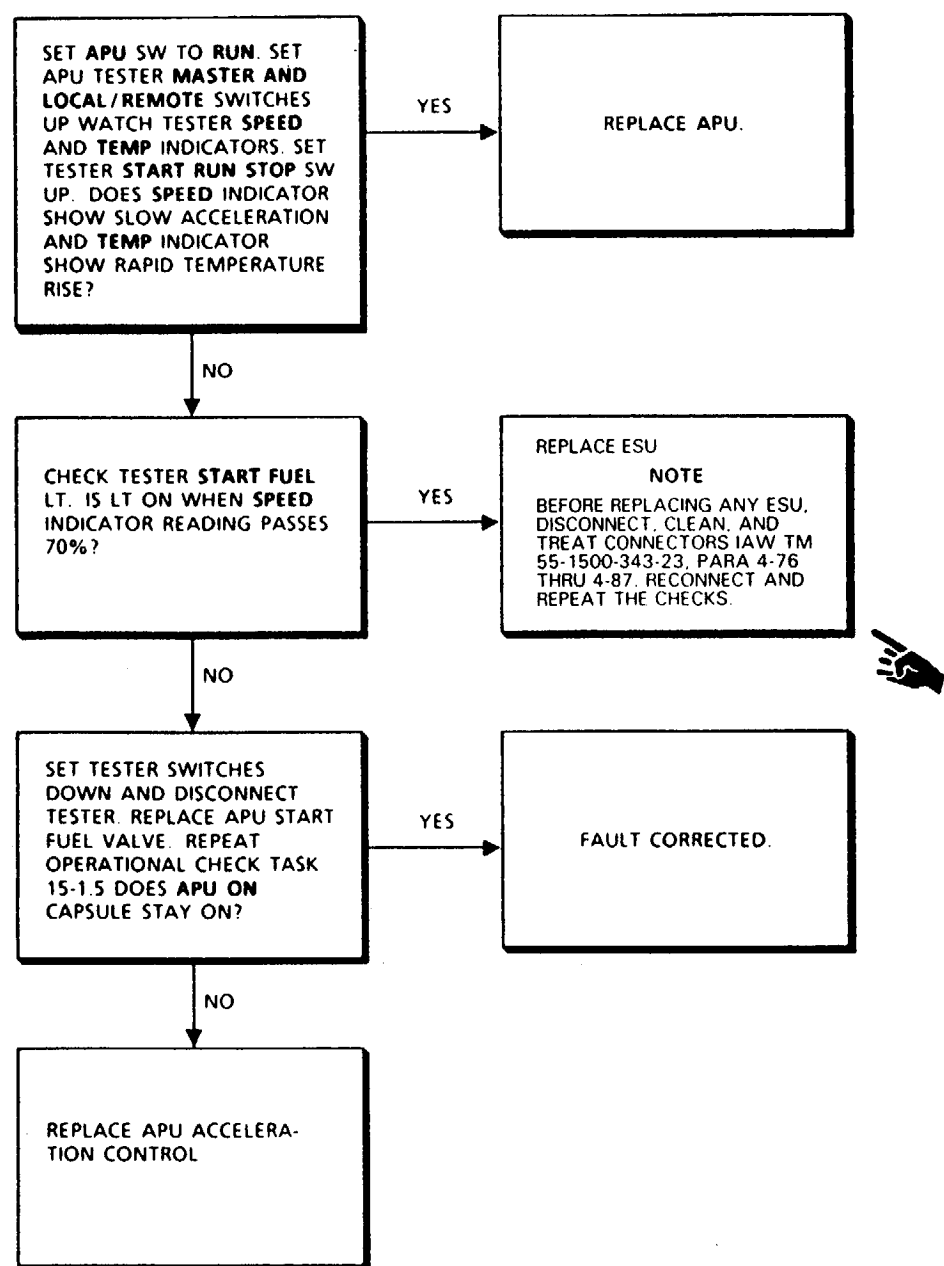

FAULT ISOLATION PROCEDURE

INITIAL SETUP

Applicable Configurations:

All

Tools:

Aircraft Mechanic's Tool Kit,

NSN 5180-00-323-4692

APU Tester 161226-200

Source Low Pressure Compressed Air

Goggles

Materials:

None

Personnel Required:

Medium Helicopter Repairer

References:

TM 55-1520-240-23

TM 55-4920-431-13

Equipment Condition:

TM 55-1520-240-23

Battery Disconnected

Electrical Power Off

Hydraulic Power Off

General Safety Instructions:

WARNING

Do not use more than 30 psi compressed air for cleaning purposes. Debris trajected under pressure can cause injury to eyes. Use source of compressed air under 30 psi and eye protection to prevent injury to personnel.

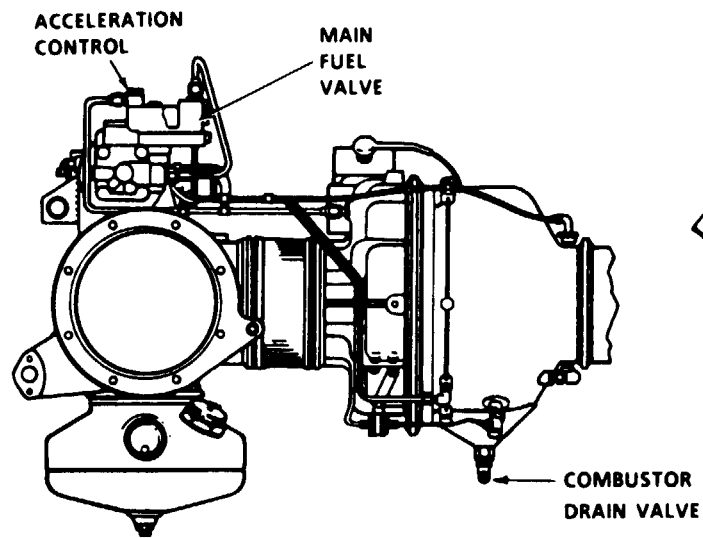
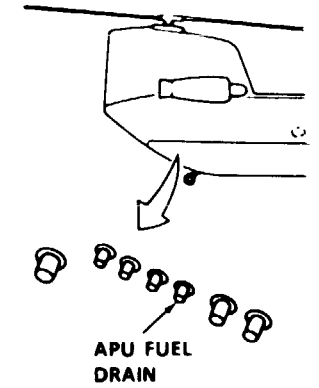
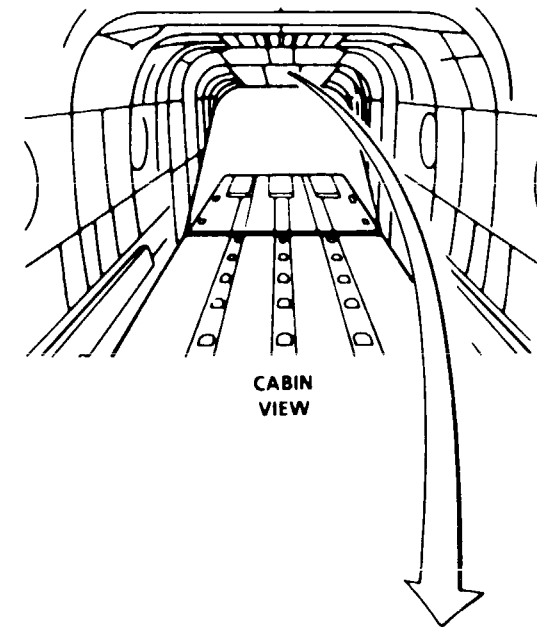

SIDE VIEW OF APU

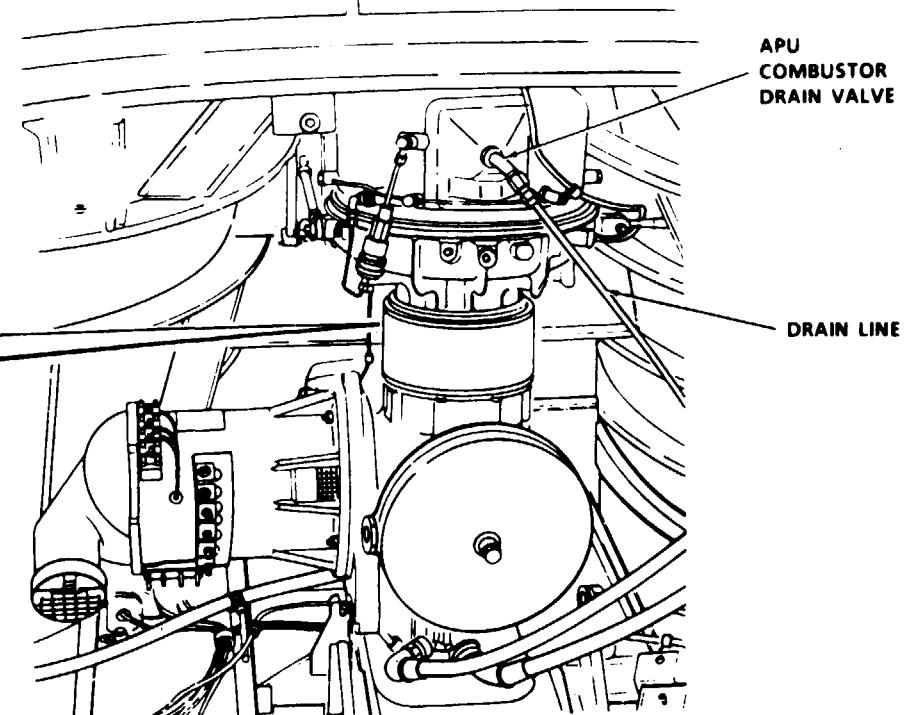

VIEW OF APU LOOKING UP AND FORWARD

15-6.17 APU STARTS AND RUNS THEN SHUTS DOWN, ESU BITE INDICATES ○ ○ ● ● (OVERTEMPERATURE) (HOT START) (CONTINUED)

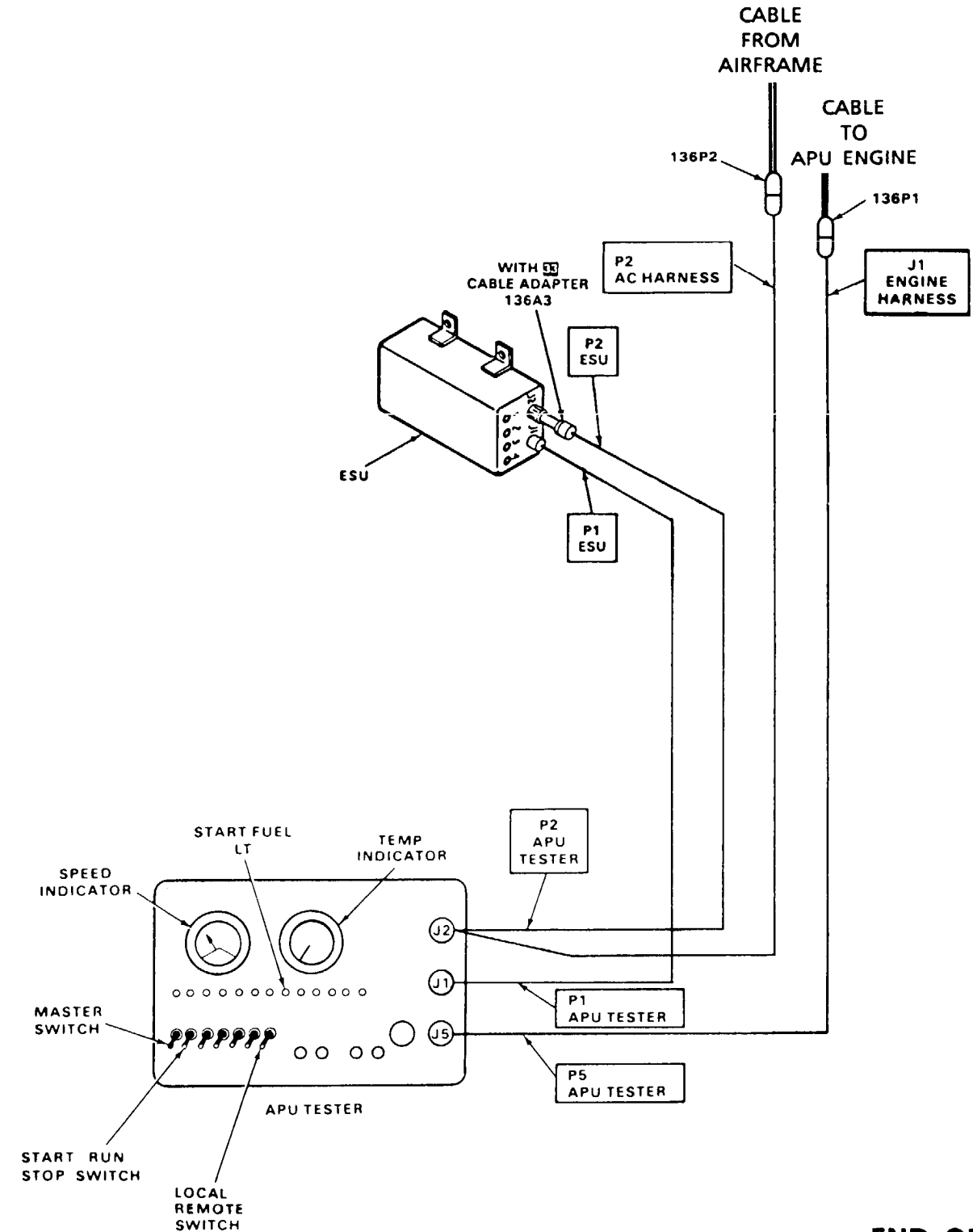
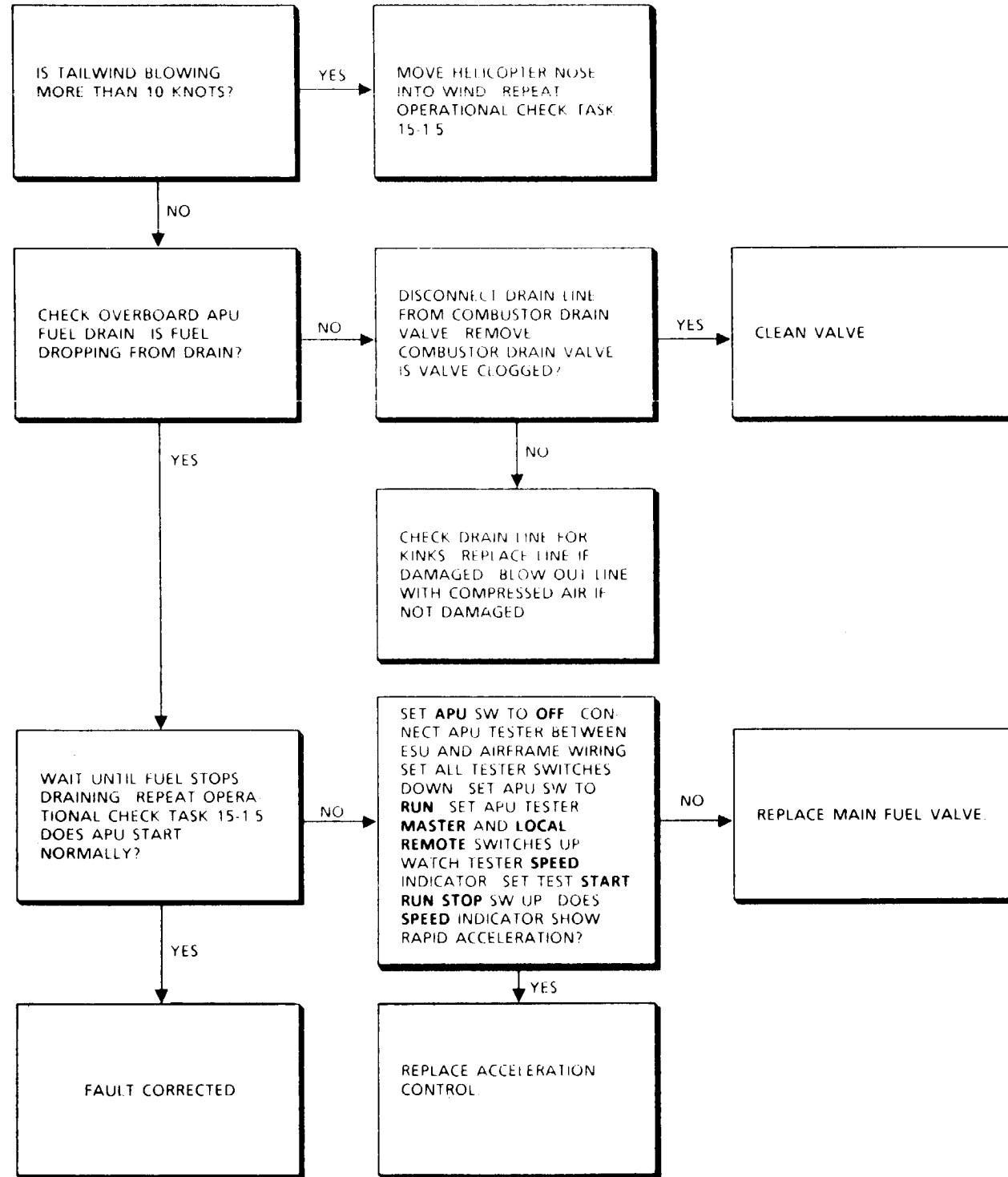

END OF TASK

15-6.18 APU STARTS BUT SHUTS DOWN, ESU BITE INDICATES (OPEN THERMOCOUPLE)

FAULT ISOLATION PROCEDURE

INITIAL SETUP

Applicable Configurations

All

Tools

Electrical Repairer's Tool Kit,
NSN 5180-00-323-4915
Multimeter

Materials

None

Personnel Required:

Aircraft Electrician

References

TM 55-1520-240-23
TM 55-1500-343-23

Equipment Condition:

TM 55-1520-240-23
Battery Connected
Electrical Power On
Hydraulic Power Off

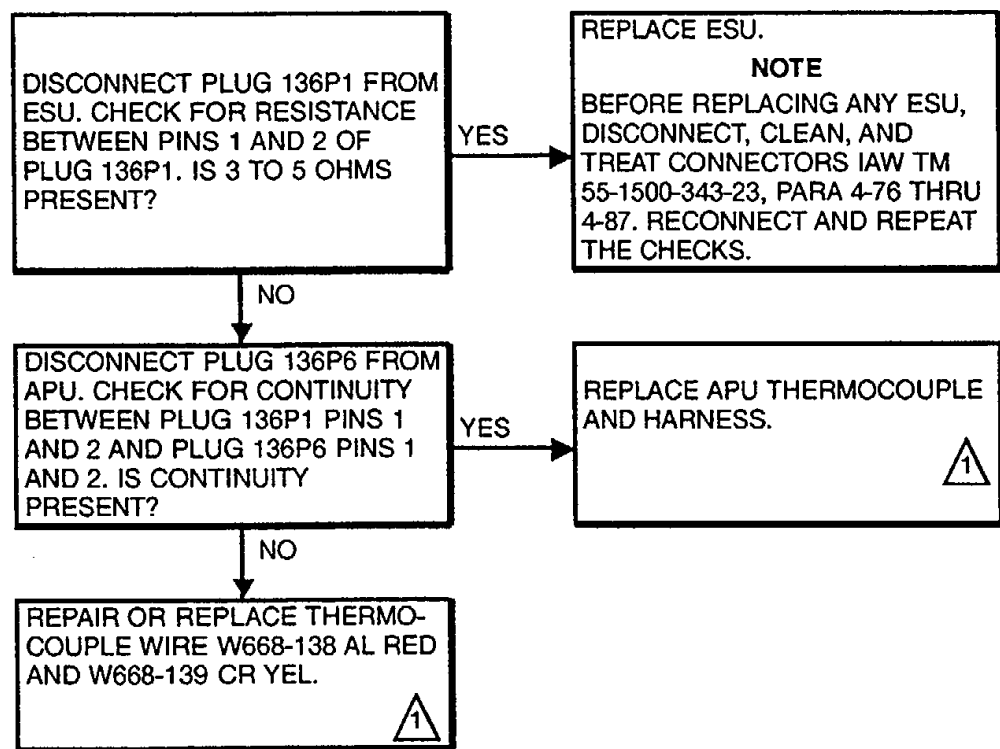
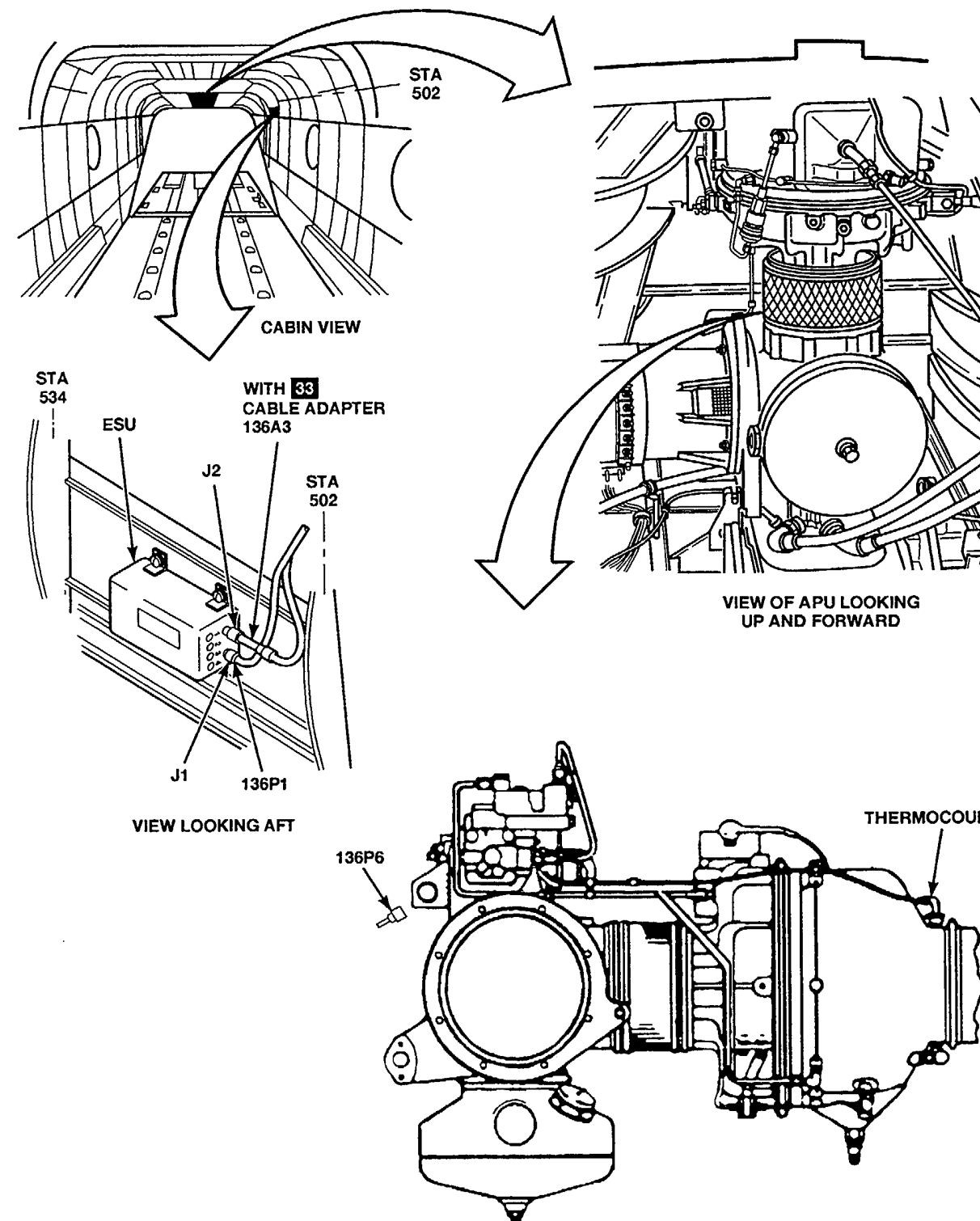

⚠ REFER TO WIRING DIAGRAM IN TASK 15-6.5 FOR FURTHER DETAILS.



A72525

END OF TASK

Change 23 15-135

15-6.19 APU STARTS AND RUNS BUT ESU BITE INDICATES ● ○ ● ○ (SHORTED THERMO. PROBE) (WARNING)

FAULT ISOLATION PROCEDURE

INITIAL SETUP

Applicable Configurations
All

Tools
Electrical Repairer's Tool Kit,
NSN 5180-00-3234915
Multimeter

Materials
None

Personnel Required:
Aircraft Electrician

References

TM 55-1520240-23
TM 55-1500-343-23

Equipment Condition:

TM 55-1520-240-23
Battery Disconnected
Electrical Power Off
Hydraulic Power Off

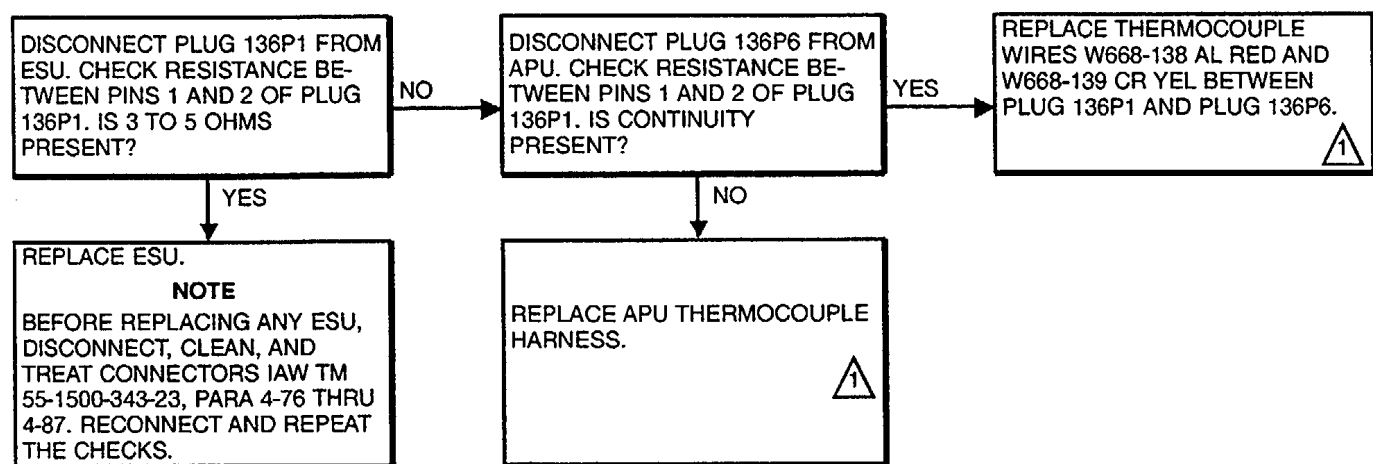
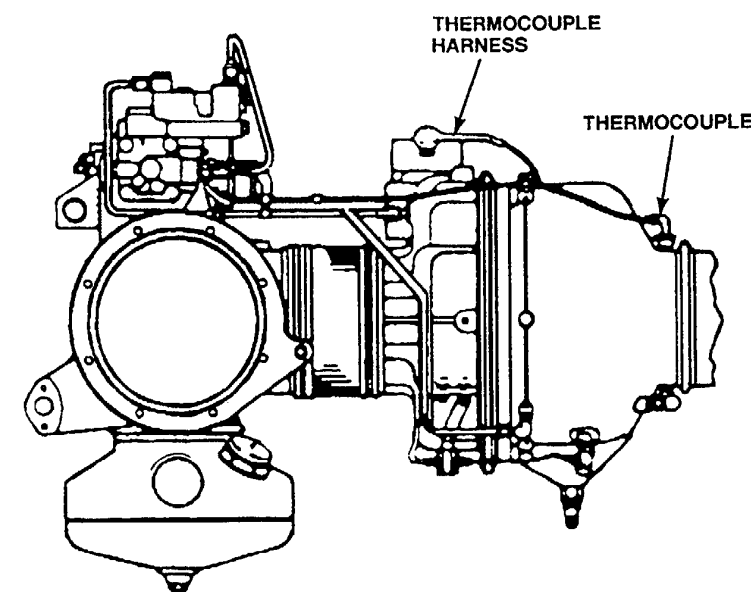
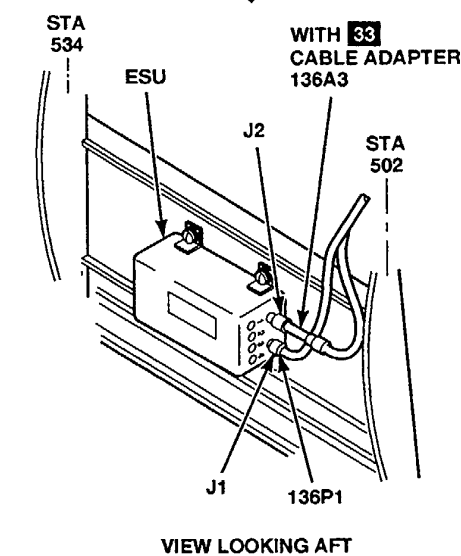
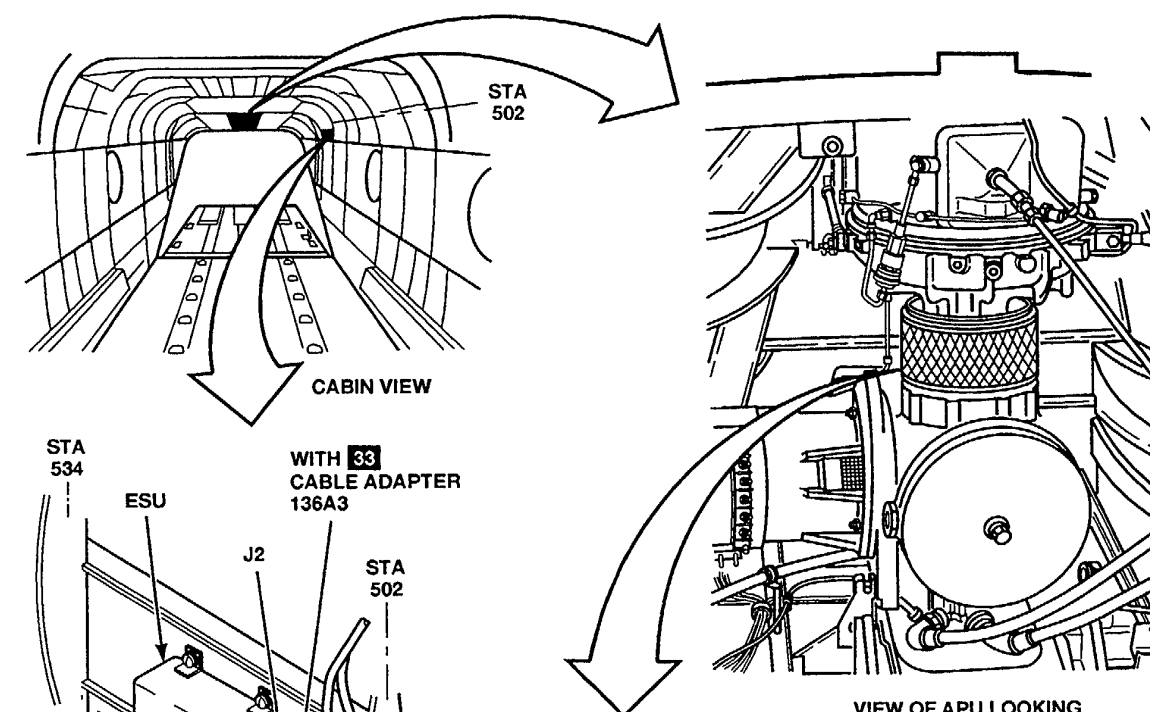

⚠ REFER TO WIRING DIAGRAM IN TASK 15-6.5 FOR FURTHER DETAILS.

A72524

END OF TASK

15-7 APU TESTER

**PARAGRAPH 15-7
TABLE OF CONTENTS
APU TESTER**

PARAGRAPH	DESCRIPTION	FUNCTION	PAGE
15-7	APU TESTER		15-137
15-7.1	PANEL LAYOUT	DRAWING	15-140
15-7.2	CONTROLS AND INDICATORS FUNCTIONS TABLE	TABLE	15-141
15-7.3	APU TESTER OPERATION	TASK	15-142

**PARAGRAPH 15-7
LIST OF TABLES
ELECTRONIC SEQUENCE UNIT (ESU) TROUBLESHOOTING**

TABLE NO.	DESCRIPTION	PAGE NO.
15-7.1	FUNCTION OF CONTROLS AND INDICATORS ON APU TESTER	15-141

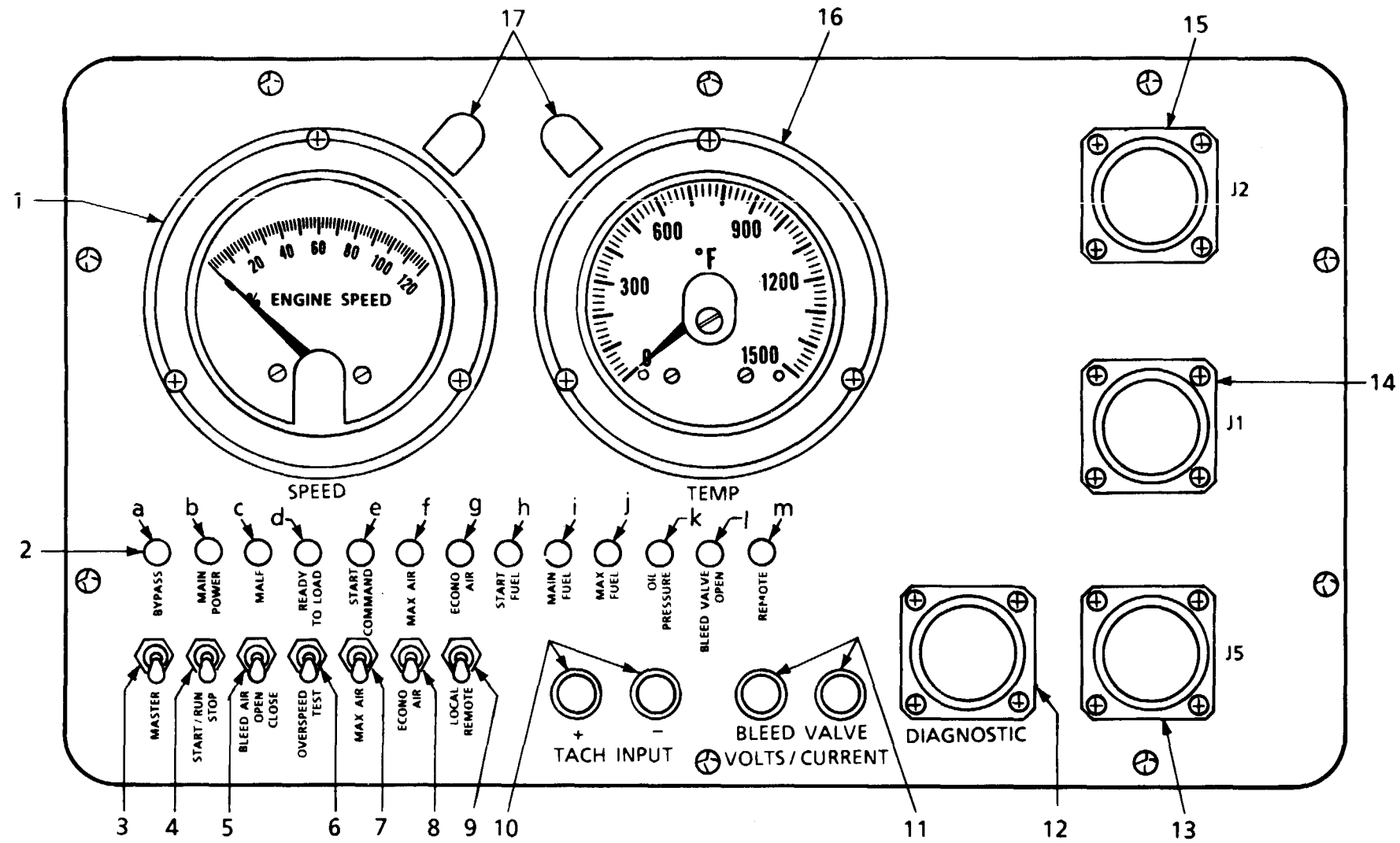

15-7.2 CONTROLS AND INDICATORS FUNCTIONS TABLE

TABLE 15-7.1
FUNCTION OF CONTROLS AND INDICATORS ON APU TESTER

ITEM 1	NOMENCLATURE	FUNCTION
1	SPEED meter	Displays % engine speed from 0 to 120.
2	Color coded LED indicators	
	a. BYPASS (grn)	Lighted - indicates voltage is applied to start bypass valve.
	b. MAIN POWER (red)	Lighted - indicates main power is on.
	c. MALF (red)	Lighted - indicates malfunction has occurred and unit is shutdown. Bite indication on ESU is checked for cause.
	d. READY TO LOAD (grn)	Lighted - indicates APU is ready to accept load.
	e. START COMMAND (grn)	Lighted - indicates start command is initiated,
	f. MAX. AIR (red)	(Not applicable)
	g. ECONO AIR (yel)	(Not applicable)
	h. START FUEL (yel)	Lighted - indicates start fuel valve voltage on approximately 5% RPM.
	i. MAIN FUEL (yel)	Lighted - indicates main fuel valve voltage on, approximately 14% RPM.
	j. MAX. FUEL (yel)	Lighted - indicates max. fuel voltage on, approximately 90% RPM + 5 sec. time out.
	k. OIL PRESSURE (yel)	Lighted when MAIN POWER is lit. Does NOT indicate Oil Pressure.
	l. BLEED VALVE OPEN (grn)	(Not applicable)
	m. REMOTE (red)	Lighted - indicates remote analog converter selected. (Actual magnetic pickup and thermocouple probe.)
3	MASTER switch	Controls 28 VDC power to Tester and ESU.

ITEM 1	NOMENCLATURE	FUNCTION
4	START/ RUN /STOP switch	Initiates start sequence of ESU and generates start signal input to tester.
5	BLEED AIR OPEN/CLOSE switch	(Not applicable)
6	OVERSPEED TEST switch	(Not applicable)
7	MAX. AIR switch	(Not applicable)
8	ECONO AIR switch	(Not applicable)
9	LOCAL/REMOTE switch	Selects local or remote analog converter. LOCAL (down position) selects analog converter in aircraft. REMOTE (up position) selects analog converter in tester. Always used in the REMOTE position.
10	TACH INPUT jacks	To monitor magnetic pickup input and input simulation signals.
11	BLEED VALVE VOLTS/ CURRENT jacks	(Not applicable)
12	DIAGNOSTIC connector	(Not applicable)
13	Connector J5	Output connector for harness connection to APU.
14	Connector J 1	Input connector for harness connection to ESU.
15	Connector J2	Input /Output connector for harness connection to ESU and Airframe harness.
16	TEMP meter	Displays exhaust gas temperature (EGT) in °F from 0 to 1500.
17	PANEL Lights	Lighted - indicates 28 VDC power is available to tester. Illuminates panel meters.

1 Refer to Paragraph 15-7.1 for location of items.

15-7.3 APU TESTER OPERATION

INITIAL SETUP

Applicable Configurations:

All

References:

TM 55-1520-240-23
 TM 55-4920-431-13

Tools:

Electrical Repairer's Tool Kit.
 NSN 5180-00-329-4915
 APU Tester 161226-200

Equipment Condition:

TM 55-1520-240-23:
 Battery Connected
 External Electrical Power Off

Materials:

None

Personnel Required:

Aircraft Electrician

TASK	RESULT
1. Turn pressure equalizer knob to OPEN.	Pressure on cover is released.
2. Open case.	
3. Remove P1, P2 and P5 harnesses.	
4. Inspect equipment for any physical damage.	Repair or replace as required.
5. Zero meters.	
6. Connect harnesses to the applicable J1, J2 and J5 connectors on test set.	
7. Remove 136P1 and 136P2 from ESU and connect to the corresponding cable connectors of harnesses.	
8. Connect the remaining harness plugs to J1 and J2 of ESU.	Wiring should be similar to that shown in accompanying diagram.
9. Perform test in accordance with applicable task.	

TASK	RESULT
NOTE	
During tests, leave BLEED AIR OPEN/CLOSE switch, MAX. AIR switch, and ECONO AIR switch in down position.	
10. After completion of task, return all tester switches to DOWN position.	
11. Disconnect harnesses and stow in cover.	
12. Close cover and rotate pressure equalizer knob to CLOSE.	Tester is secured.
13. Report any tester operation problems on proper form as described in DA Pam 738-751.	

FOLLOW-ON MAINTENANCE:
 TM55-4920-431-13
 REFER TO TASK BEING PERFORMED.

GO TO NEXT PAGE

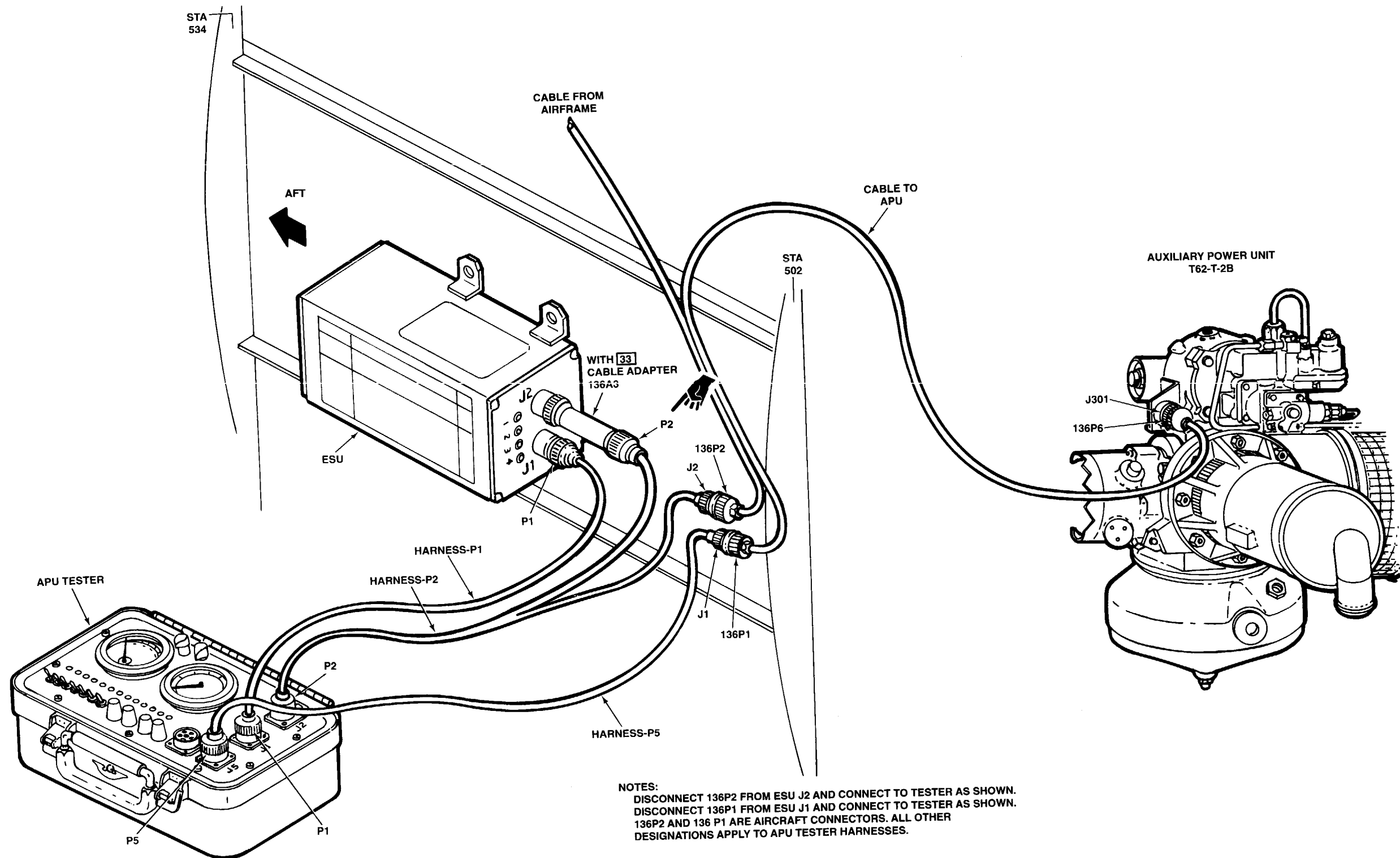

33315

CHAPTER 16

MISSION EQUIPMENT TROUBLESHOOTING



**CHAPTER 16
MISSION EQUIPMENT TROUBLESHOOTING**

CHAPTER OVERVIEW

Chapter 16 contains procedures for Mission Equipment troubleshooting. Each system and failure symptom is listed below. Included in this chapter are locations and views of all electrical connectors, receptacles, relays, and ground connections for the Mission Equipment.

Refer to TM 55-1520-240-23 for required maintenance procedures.

SYSTEM	PARA
EXTERNAL CARGO HOOK SYSTEM	16-1
FLARE DISPENSER SYSTEM	16-2
ENGINE AIR PARTICLE SEPARATOR SYSTEM	16-3
HEAD UP DISPLAY SYSTEM	16-4
COUNTERMEASURES DISPENSER SYSTEM	16-5

FAILURE SYMPTOM LIST

EXTERNAL CARGO HOOK SYSTEM

SYMPTOM	TASK
FWD OR AFT HOOK LOADED LIGHT IS LIT WHEN CARGO HOOK IS UNLOADED	16-1.5
FORWARD OR AFT HOOK LOADED LIGHT DOES NOT COME ON WHEN PRESSED	16-1.6
CARGO HOOK PWR EMER REL CIRCUIT BREAKER DOES NOT STAY CLOSED	16-1.7
CARGO HOOK CONT EMER REL CIRCUIT BREAKER DOES NOT STAY CLOSED	16-1.8
CARGO HOOK PWR NORM RLSE CIRCUIT BREAKER DOES NOT STAY CLOSED	16-1.9
CARGO HOOK CONT NORM RLSE CIRCUIT BREAKER DOES NOT STAY CLOSED	16-1.10
FWD HOOK OPEN CAPSULE LIT WHEN FORWARD CARGO HOOK CLOSED	16-1.11
MID HOOK OPEN CAPSULE LIT WHEN CENTER CARGO HOOK CLOSED	16-1.12
AFT HOOK OPEN CAPSULE IT WHEN AFT CARGO HOOK CLOSED	16-1.13

SYMPTOM	TASK
DUAL HOOK FAULT CAPSULE LIT	16-1.14
DUAL HOOK RELAY BOX LIGHT(S) DO NOT COME ON WHEN PRESSED	16-1.15
DUAL HOOK FAULT LIGHT DOES NOT COME ON WITH HOOK DISCONNECTED	16-1.16
ARMED SW FAIL LIGHT DOES NOT COME ON WITH MASTER SWITCH AT ARM	16-1.17
RELEASE SW FAIL LIGHT OR GROUND RELAY ACTIVATE LIGHT NOT ON WHEN PILOT'S CARGO HOOK RELEASE SWITCH PRESSED	16-1.18
RELEASE SW FAIL LIGHT OR GROUND RELAY ACTIVATE LIGHT NOT ON WHEN COPILOT'S CARGO HOOK RELEASE SWITCH PRESSED	16-1.19
RELEASE SW FAIL LIGHT OR GROUND RELAY ACTIVATE LIGHT NOT ON WHEN HOIST OPERATOR'S CARGO HOOK RELEASE SWITCH PRESSED	16-1.20
FORWARD CARGO HOOK DOES NOT OPEN	16-1.21

SYMPTOM	TASK
FWD HOOK OPEN CAPSULE DOES NOT COME ON WHEN FORWARD CARGO HOOK CLOSED	16-1.22
CENTER CARGO HOOK DOES NOT OPEN	16-1.23
MID HOOK OPEN CAPSULE DOES NOT COME ON WHEN CENTER CARGO HOOK OPENS	16-1.24
AFT CARGO HOOK DOES NOT OPEN	16-1.25
AFT HOOK OPEN CAPSULE DOES NOT COME ON WHEN AFT CARGO HOOK OPENS	16-1.26
CARGO HOOK OR HOOKS DO NOT RELEASE WHEN EMER SWITCH SET TO REL ALL	16-1.27
CENTER CARGO HOOK DOES NOT STAY OPEN FOR 10 TO 14 SECONDS AFTER EMERG SWITCH RELEASED FROM REL ALL	16-1.28
FORWARD OR AFT CARGO HOOK DOES NOT OPEN WHEN TANDEM HOOK RELEASE LEVER IS PULLED	16-1.29
HOOK LOADED LIGHT DOES NOT COME ON WHEN FORWARD OR AFT CARGO HOOK IS LOADED	16-1.30

FAILURE SYMPTOM LIST (Continued)

GO TO NEXT PAGE

FLARE DISPENSER SYSTEM

SYMPTOM	TASK
CHAFF CIRCUIT BREAKER WILL NOT STAY CLOSED	16-2.4
LANDING GEAR SWITCH STATUS LIGHT IS ON	16-2.5
LDG GR SW STATUS READY TO FIRE, OR LDG GR SW BYPASS LIGHTS DO NOT COME ON WHEN PRESSED	16-2.6
LDG GR SW STATUS LIGHT DOES NOT COME ON	16-2.7

SYMPTOM	TASK
READY TO FIRE LIGHT DOES NOT COME ON	16-2.8
LDG GR SW STATUS AND READY TO FIRE AND LDG GR SW BYPASS LIGHTS DO NOT COME ON	16-2.10
FLARE COUNTER SEQUENCES FROM 30 TO 00 WHEN DISP CONT PANEL ARM SAFE SWITCH SET TO ARM	16-2.11
ARM LIGHT DOES NOT COME ON WHEN ARM SAFE SWITCH SET TO ARM	16-2.12

SYMPTOM	TASK
FLARE COUNTER OR TEST SET LIGHTS DO NOT CHANGE WHEN PILOT OR COPILOT FLARE DISP SWITCH PRESSED AND RELEASED	16-2.13
FLARE COUNTER OR TEST SET LIGHTS DO NOT CHANGE WHEN A CABIN FIRING SWITCH PRESSED AND RELEASED	16-2.14
FLARE COUNTER DOES NOT INDICATE 00 WHEN RIPPLE FIRE SWITCH IS HELD UP	16-2.15

EAPS SYSTEM

SYMPTOM	TASK
EAPS 1 FAN. FAN CONT OR BYPASS DOORS CIRCUIT BREAKER WILL NOT STAY CLOSED	16-3.5
EAPS 2 FAN. FAN CONT OR BYPASS DOORS CIRCUIT BREAKER WILL NOT STAY CLOSED	16-3.6
NO. 1 OR NO. 2 ENG EAPS BYPASS DOORS OPEN LIGHT DOES NOT COME ON WHEN PRESSED	16-3.7
115 VAC IS NOT PRESENT WITH EAPS ENG 1 FAN SWITCH SET TO ON	16-3.8
28 VDC IS NOT PRESENT ON RECEPTACLE 151J1 PIN U WITH EAPS ENG 1 DOORS SWITCH AT OPEN	16-3.9

SYMPTOM	TASK
GROUND IS NOT PRESENT ON RECEPTACLE 151J1 PIN <u>a</u> WITH EAPS ENG 1 DOORS SWITCH AT OPEN	16-3.10
28VDC IS NOT PRESENT ON RECEPTACLE 151J1 PIN <u>a</u> WITH EAPS ENG 1 DOORS SWITCH AT CLOSE	16-3.11
GROUND IS NOT PRESENT ON RECEPTACLE 151J1 PIN U WITH EAPS ENG 1 DOORS SWITCH AT CLOSE	16-3.12
EAPS 1 FAIL CAPSULE DOES NOT COME ON	16-3.13
115 VAC IS NOT PRESENT WITH EAPS ENG 2 FAN SWITCH SET TO ON	16-3.14

SYMPTOM	TASK
28 VDC IS NOT PRESENT ON RECEPTACLE 151J2 PIN U WITH EAPS ENG 2 DOORS SWITCH AT OPEN	16-3.15
GROUND IS NOT PRESENT ON RECEPTACLE 151J2 PIN <u>a</u> WITH EAPS ENG 2 DOORS SWITCH AT OPEN	16-3.16
28 VDC IS NOT PRESENT ON RECEPTACLE 151J2 PIN <u>a</u> WITH EAPS ENG 2 DOORS SWITCH AT CLOSE	16-3.17
GROUND IS NOT PRESENT ON RECEPTACLE 151J2 PIN U WITH EAPS ENG 2 DOORS SWITCH AT CLOSE	16-3.18
EAPS 2 FAIL CAPSULE DOES NOT COME ON	16-3.19

HEAD UP DISPLAY SYSTEM

SYMPTOM	TASK
CCU PANEL WILL NOT ILLUMINATE	16-4.4
FAIL LAMP ON CCU IS ON	16-4.5
ON AND/OR FAIL LAMPS WILL NOT ILLUMINATE	16-4.6
PILOT'S AND/OR COPILOT'S DISPLAY HAS NO DISPLAY	16-4.7
PILOT'S AND/OR COPILOT'S DISPLAY REMAINS AT MAXIMUM INTENSITY	16-4.8
PDU AND CPDU TEST DISPLAY INDICATES INCORRECT TYPE AIRCRAFT	16-4.9
SYMBOL DOES NOT STOP BLINKING	16-4.10
PILOT CANNOT SELECT DECLUTTER ON CCU	16-4.11

SYMPTOM	TASK
COPILOT CANNOT SELECT DECLUTTER ON CCU	16-4.12
CANNOT CYCLE THROUGH MODES AT PILOT'S THRUSTER GRIP	16-4.13
CANNOT CYCLE THROUGH DECLUTTER AT PILOT'S THRUSTER GRIP	16-4.14
PILOT'S BRT CONTROL ON THRUSTER DOES NOT VARY DISPLAY INTENSITY	16-4.15
PILOT'S DIM CONTROL ON THRUSTER DOES NOT VARY DISPLAY INTENSITY	16-4.16
CANNOT CYCLE THROUGH MODES AT COPILOT'S THRUSTER GRIP	16-4.17

SYMPTOM	TASK
CANNOT CYCLE THROUGH CLUTTER AT COPILOT'S THRUSTER GRIP	16-4.18
COPILOTS' BRT CONTROL ON THRUSTER DOES NOT VARY DISPLAY INTENSITY	16-4.19
COPILOT'S DIM CONTROL ON THRUSTER DOES NOT VARY DISPLAY INTENSITY	16-4.20
CANNOT VARY PILOT'S DISPLAY LEFT/RIGHT	16-4.21
CANNOT VARY PILOT'S DISPLAY UP/DOWN	16-4.22
CANNOT VARY COPILOT'S DISPLAY LEFT/RIGHT	16-4.23
CANNOT VARY COPILOT'S DISPLAY UP/DOWN	16-4.24

GO TO NEXT PAGE

FAILURE SYMPTOM LIST (Continued)

HEAD UP DISPLAY SYSTEM (Continued)

SYMPTOM	TASK
CANNOT CYCLE THROUGH PILOT'S MODE SELECTION AT CCU OR PILOT'S THRUSTER GRIP HUD CONTROL SWITCH	16-4.25
CANNOT CYCLE THROUGH PILOT'S DECLUTTER AT CCU OR PILOT'S THRUSTER GRIP HUD CONTROL SWITCH	16-4.26

SYMPTOM	TASK
CANNOT CYCLE THROUGH COPILOT'S MODE SELECTION AT CCU OR COPILOT'S THRUSTER GRIP HUD CONTROL SWITCH	16-4.27
CANNOT CYCLE THROUGH COPILOT'S DECLUTTER AT CCU OR COPILOT'S THRUSTER GRIP HUD CONTROL SWITCH	16-4.28

SYMPTOM	TASK
NO OR IMPROPER ALTITUDE (MSL) OR AIRSPEED DISPLAYED	16-4.29
NO OR IMPROPER TRIM (SLIDE BALL) DISPLAYED	16-4-30

COUNTERMEASURES DISPENSER SYSTEM

SYMPTOM	TASK
DCDU CIRCUIT BREAKER WILL NOT STAY CLOSED	16-5.4
LANDING GEAR SWITCH STATUS LIGHT IS ON	16-5.5
LANDING GEAR SWITCH STATUS, READY TO FIRE, OR LANDING GEAR BYPASS LIGHTS DO NOT LIGHT DURING PRESS TO TEST	16-5.6
LANDING GEAR SWITCH STATUS LIGHT DOES NOT COME ON	16-5.7

SYMPTOM	TASK
READY TO FIRE LIGHT DOES NOT COME ON	16-5.8
COUNTERMEASURES DISPENSER TEST SET DOES NOT INDICATE A FIRED EXPENDABLE WHEN COPILOT'S FLARE DISP SWITCH IS PRESSED	16-5.9
COUNTERMEASURES DISPENSER TEST SET DOES NOT INDICATE A FIRED EXPENDABLE WHEN PILOT'S FLARE DISP SWITCH IS PRESSED	16-5.10

SYMPTOM	TASK
COUNTERMEASURES DISPENSER TEST SET DOES NOT INDICATE A FIRED EXPENDABLE WHEN ONE CREW DISPENSE SWITCH IS PRESSED	16-5.11
DCDU DISPLAYS INCORRECT QUANTITY OF EXPENDABLES	16-5.12
LANDING GEAR BYPASS SWITCH LIGHT DOES NOT COME ON	16-5.13

GO TO NEXT PAGE

MISSION EQUIPMENT ELECTRICAL COMPONENT LOCATION AND CONFIGURATION LIST

REF DESIG	PART NUMBER	TYPE	MATE WITH/LOCATION	FS	WL	BL	REF DESIG	PART NUMBER	TYPE	MATE WITH/LOCATION	FS	WL	BL
GD005		150	CONSOLE – FWD CTR INSTR PNL				147J50	MS27484T16B35S	A	RH AFT FUSELAGE LOWER	544	42	40L
GD040		150	CONSOLE – FWD CTR INSTR PNL				147P30	MS27467T19B35S	60	CONSOLE – CTR INST PNL – DCDU	60	-9	1R
GD123		151	RH CABIN AFT	482	-5	50R	147P32	D38999/26WH35SN	162	CMDS JUNCTION BOX – J1	415	55	22.5L
GD189		151	RH CABIN	265	30	50R	147P33	D38999/26WH35PN	162	CMDS JUNCTION BOX – J2	406	55	22.5L
GD190		151	RH CABIN	265	30	50R	147P34	MS3475W16-26S	24	CMDS PROGRAMMER – J1	415	42	40L
GD191		151	LH CABIN	255	30	50L	147P35	MS27484T18B35S	60	CMDS PROGRAMMER – J2	355	42	40L
GD193		151	CABIN – UNDERFLOOR	330	-36	40L	147P36	MS27484T10B35SA	317	CMDS SAFETY SWITCH – J1	519	50	50L
GD259		151	CABIN – UNDERFLOOR	255	-36	30L	147P37	MS27484T10B35S	317	CMDS SAFETY SWITCH – J2	519	50	50L
GD260		151	CABIN – UNDERFLOOR	410	-36	20L	147P40	MS27484T16B35SA		NO. 1 SEQUENCER – J3	544	42	40L
GD289		151	LH CABIN – AFT	535	32	52L	147P41	MS27497T16B35SA		LH AFT CABIN UPPER	544	42	40L
GD308		151	RH CABIN	300	40	52R	147P42	MS27484T16B35P		LH AFT FUSELAGE UPPER FLARE DISPENSER	544	42	40L
GD309		151	RH CABIN	300	40	52R	147P43	MS27484T16B35S		NO. 1 SEQUENCER – J1	544	42	40L
GD311		151	LH CABIN – AFT	570	20	52L	147P44	MS27497T16B35S		LH AFT CABIN LOWER	544	42	40L
GD323		151	LH CABIN – AFT	535	32	52L	147P45	MS27484T16B35P		LH AFT FUSELAGE LOWER FLARE DISPENSER	544	42	40L
TB6			CONSOLE – FWD FLOOR				147P46	MS27484T16B35SA		NO. 2 SEQUENCER – J3	544	42	40R
TB7			CONSOLE – FWD CTR INSTR PNL				147P47	MS2749T16B35S		RH AFT CABIN UPPER	544	42	40R
TB18			COCKPIT UNDERFLOOR – COPILOT	87	-13	11L	147P48	MS27484T16B35P		RH AFT FUSELAGE UPPER FLARE DISPENSER	544	42	40R
TB27			RH CABIN	332	-13	11L	147P49	MS27484T16B35S		NO. 2 SEQUENCER – J1	544	42	40R
TB36			OVERHEAD PANEL – COCKPIT	80	40	12R	147P50	MS2749T16B35S		RH AFT CABIN LOWER	544	42	40R
TB59			NO. 1 PDP SIDE PANEL	90	-15	30L	147P51	MS27484T16B35P		RH AFT FUSELAGE LOWER FLARE DISPENSER	544	42	40R
TB62			NO. 2 PDP SIDE PANEL	90	-15	30R	202P4	MS3476W14-19S	21	CONSOLE, CONTROL IND			
TB401			RH CABIN – FLARE DISP	185	-20	55L	232P1	MS3476W20-41S	26	CONSOLE – CTR INST PNL – MASTER			
147K1	MS24149-D1	106	LH POD	482	22	50R				CAUTION PANEL (WITHOUT 74)			
148K2	BACR13CR-2AB	103	RH AFT CABIN				232P1	MS3476W22-51S	161	CONSOLE – CTR INST PNL – MASTER			
232K2	BACR13CG-2AB	103	CONSOLE – FLOOR	340	40	50R				CAUTION PANEL (WITH 74)			
132J11	MS3470W14-19S	21	HOIST OPR PNL				232P2	MS3476W16-26S	24	CONSOLE – CTR INST PNL – MASTER			
134P1	MS3476W14-19S	21	OVHD PNL – HOIST/CARGO PNL – J1							CAUTION PANEL			
134P2	MS3476W14-19SW	21	OVHD PNL – HOIST/CARGO PNL – J2				232P3	MS3476W14-19S	21	CONSOLE – CTR INST PNL – MASTER			
134P3	MS3476W16-8S	22	DUAL HOOK RELAY BOX – J1	270	35	50R				CAUTION PANEL (WITH 74)			
134P4	MS3476W16-26S	24	DUAL HOOK RELAY BOX – J2	270	35	50R	300J1	M83723-74A2041N	40	NO. 1 PDP			
134P5	MS3476W10-6S	15	EMERG HOOK REL RELAY BOX – J1	270	25	50L	300P1	M83723-75A2041N	40	NO. 1 PDP			
134P6	MS3476W16-8S	22	EMERG HOOK REL RELAY BOX – J2	270	25	50L	300J4	M83723-74A2461N	43	NO. 1 PDP			
134J7	MS3474W16-8S	22	FWD CARGO HOOK RCPT	248	-36	12L	300P4	M83723-74A2461N	43	NO. 1 PDP			
134P7		22	FWD CARGO HOOK	248	-37	12L	300J5	M83723-75A2461N	40	NO. 2 PDP			
134J8	MS3474W10-6S	15	CTR CARGO HOOK RCPT	331	-36	40L	300P5	M83723-75A2461N	40	NO. 2 PDP			
134P8	MS3476W10-6P	15	CTR CARGO HOOK	331	-36	40L	300J15	M83723-75A24617	43	CONSOLE – UNDERFLOOR	85	-20	
134J9	MS3474W16-8S	22	AFT CARGO HOOK RCPT	409	-36	12L	300P15	M83723-75A24617	43	CONSOLE – UNDERFLOOR	85	-20	
134P9		22	AFT CARGO HOOK	409	-37	12L	300J18	M83723-73A2041N	40	OVERHEAD PANEL – COCKPIT			
134P10	M83723-95A0803N	29	CARGO HOOK NORM REL VALVE – IN TUNNEL AREA	332	51	17L	300P18	M83723-76A2041N	40	OVERHEAD PANEL – COCKPIT			
147P1	MS3476W14-19S	21	CONSOLE, DISP CONT				300J19	M83723-73A2041N	40	OVERHEAD PANEL – COCKPIT			
147P2	MS3476W12-10S	17	RH CABIN, TIMER	300	30	52R	300J20	M83723-74A2461N	43	OVERHEAD PANEL – COCKPIT			
147P3		21	LH AFT, RAMP AREA	560	10	52L	300P20	M83723-75A2461N	43	OVERHEAD PANEL – COCKPIT			
147P4	MS3476W10-6S	15	LH AFT, RAMP AREA	536	40	52L	300J23	M83723-74A2255N	42	OVERHEAD PANEL – COCKPIT			
147J5	M83723-84A1005N	30	LH AFT, CABIN	400	40	52L	300P23	M83723-75A2255N	42	OVERHEAD PANEL – COCKPIT			
147J6	M83723-84A1005N	30	LH FWD, CABIN	200	40	52L	300J29	MS3474W14-19S	21	COCKPIT – UNDERFLOOR – PILOT	65	-27	25R
147J7	M83723-84A1005N	30	RH AFT, CABIN	400	40	52L	300P29	MS3476W14-19P	21	COCKPIT – UNDERFLOOR – PILOT	65	-27	25R
147J8	M83723-84A1005N	30	RH FWD, CABIN	105	40	52R	300J30	MS3474W14-19S	21	COCKPIT – UNDERFLOOR – PILOT	70	-27	25L
147J41	MS27484T16B35S	A	LH AFT FUSELAGE UPPER	544	42	40L	300J48	M83723-74A2461N	43	ELECTRONICS COMPARTMENT – OVHD	120	40	20L
147J44	MS27484T16B35S	A	LH AFT FUSELAGE LOWER	544	42	40L	300P48	M83723-75A2461N	43	ELECTRONICS COMPARTMENT – OVHD	120	40	20L
147J47	MS27484T16B35S	A	RH AFT FUSELAGE UPPER	544	42	40L	300J50	M83723-73A2461N	43	ELECTRONICS COMPARTMENT – OVHD	120	40	20L
							300P50	M83723-76A2461N	43	ELECTRONICS COMPARTMENT – OVHD	120	40	20L

GO TO NEXT PAGE

MISSION EQUIPMENT COMPONENT LOCATION AND CONFIGURATION LIST (Continued)

REF DESIG	PART NUMBER	TYPE	MATE WITH/LOCATION	FS	WL	BL	REF DESIG	PART NUMBER	TYPE	MATE WITH/LOCATION	FS	WL	BL
300J52	M83723-74A2255N	42	AFT CROWN	460	45	30L	300J68	M83723-73A22556	42	HEATER COMPARTMENT – OVHD	105	40	30R
300P52	M83723-75A2255N	42	AFT CROWN	460	45	30L	300P68	M83723-76A22556	42	HEATER COMPARTMENT – OVHD	105	40	30R
300J53	M83723-74A2255N	42	AFT CROWN	460	45	20R	P2000R	D38999/26WC98SN	160	LH ELECTRONICS BAY			
							P2001R	D38999/26WH35SA	162	LH ELECTRONICS BAY			
300P53	M83723-75A2255N	42	AFT CROWN	460	45	20R	P2002R	D38999/26WH35SN	162	LH ELECTRONICS BAY			
300J54	M83723-74A2461N	43	AFT CROWN	460	45	20L	P2003R	MS27505E13B35P	164	BULKHEAD 95 PILOT'S SIDE			
300P54	M83723-75A2461N	43	AFT CROWN	460	45	20L	P2004R	MS27505E13B25P	164	BULKHEAD 95 COPILOT'S SIDE			
300J64	M83723-73A24617	43	CONSOLE – UNDERFLOOR	85	-20		P2005R	D38999/26WD35SN	166	UPPER CONSOLE			
300P64	M83723-76A24617	43	CONSOLE – UNDERFLOOR	85	-20		P2008R	D38999/26WC98SN	160	LH ELECTRONICS BAY			
							P2009R	D38999/26WA35SN	168	LH ELECTRONICS BAY			

GO TO NEXT PAGE

MISSION EQUIPMENT ELECTRICAL COMPONENT LOCATION AND CONFIGURATION LIST (Continued)

RECEPTACLE

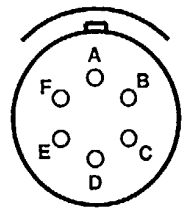

15

PLUG

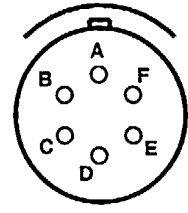

15

RECEPTACLE

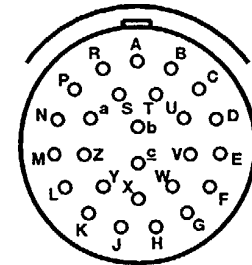

24

PLUG

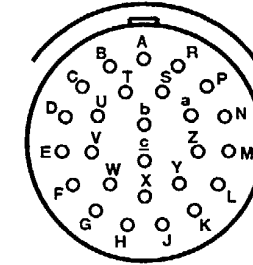

24

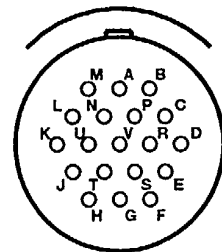

21

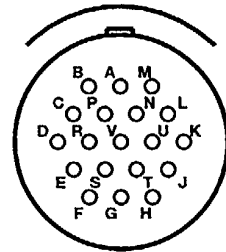

21

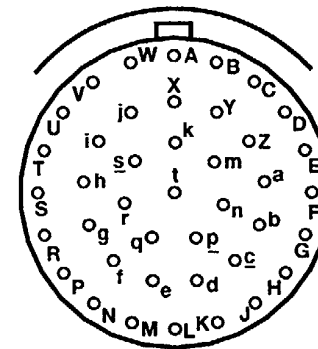

26

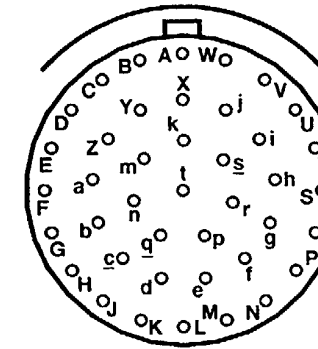

26

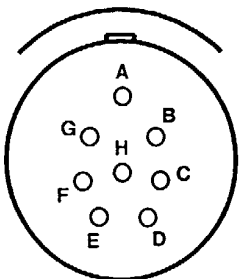

22

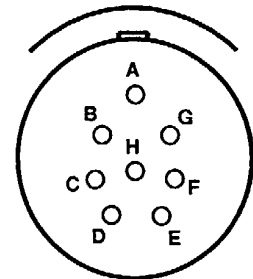

22

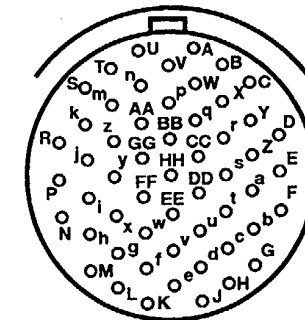

27

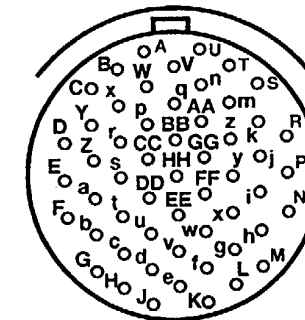

27

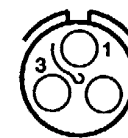

29



29

A65609

GO TO NEXT PAGE

Change 23 16-2.5

MISSION EQUIPMENT ELECTRICAL COMPONENT
LOCATION AND CONFIGURATION LIST (Continued)

RECEPTACLE

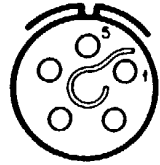

30

PLUG



30

RECEPTACLE

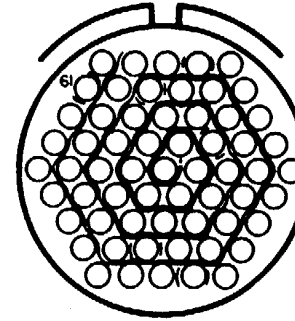

43

PLUG

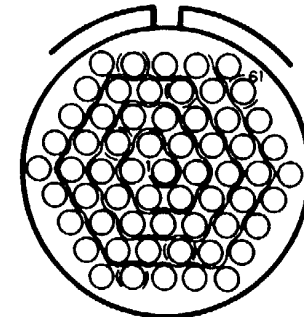

43

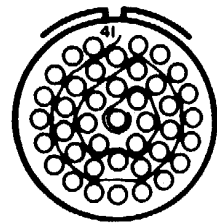

40

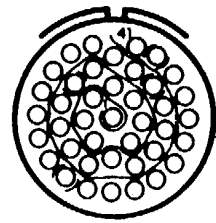

40

RELAY

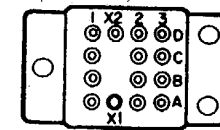

103

RELAY

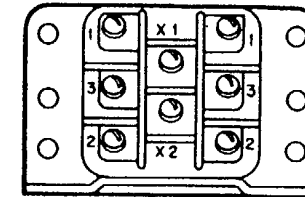

106

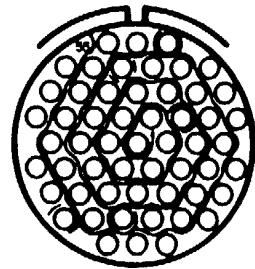

42

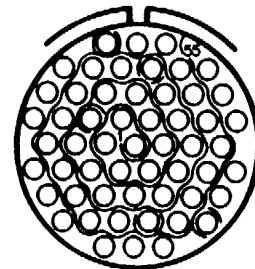

42

GND MODULE

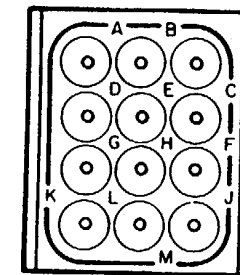

150

GND STUD



151

90 x 54

DI45-1:873-SPA

MISSION EQUIPMENT SYSTEM ELECTRICAL COMPONENT LOCATION AND CONFIGURATION LIST (Continued)

RECEPTACLE

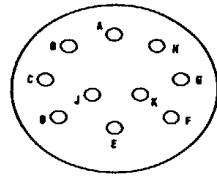

160

PLUG

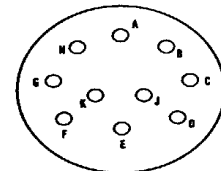

160

RECEPTACLE

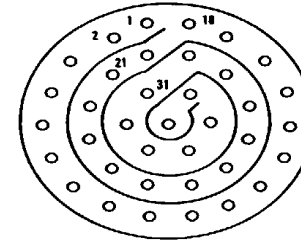

166

PLUG

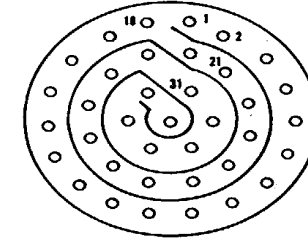

166

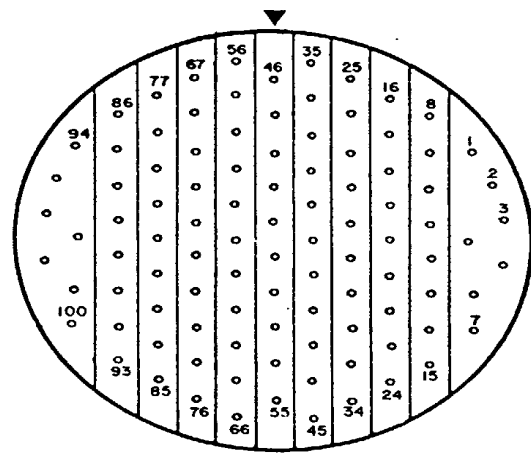

162

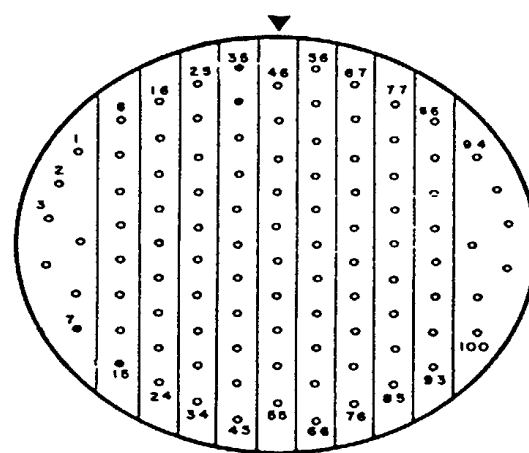

162

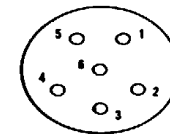

168

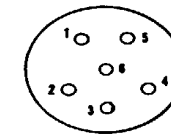

168

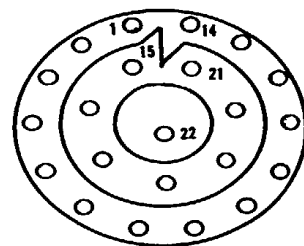

164

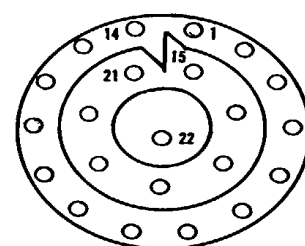

164

MISSION EQUIPMENT COMPONENT LOCATION AND CONFIGURATION LIST (Continued)

RECEPTACLE

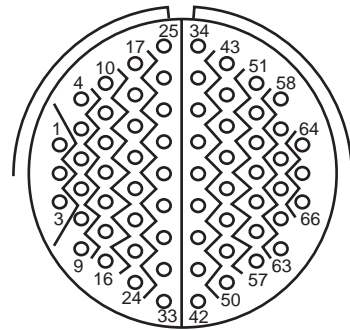

60

PLUG

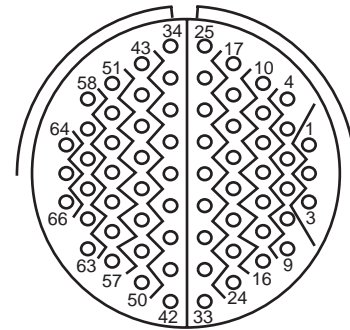

60

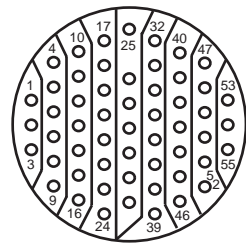

A

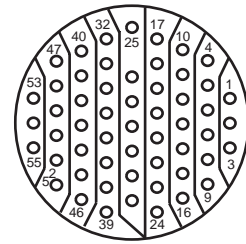

A

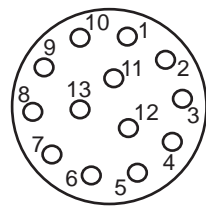

317

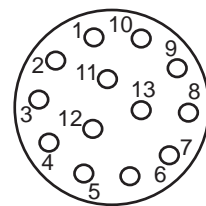

317

WT0049

END OF TASK

16-1 EXTERNAL CARGO HOOK SYSTEM

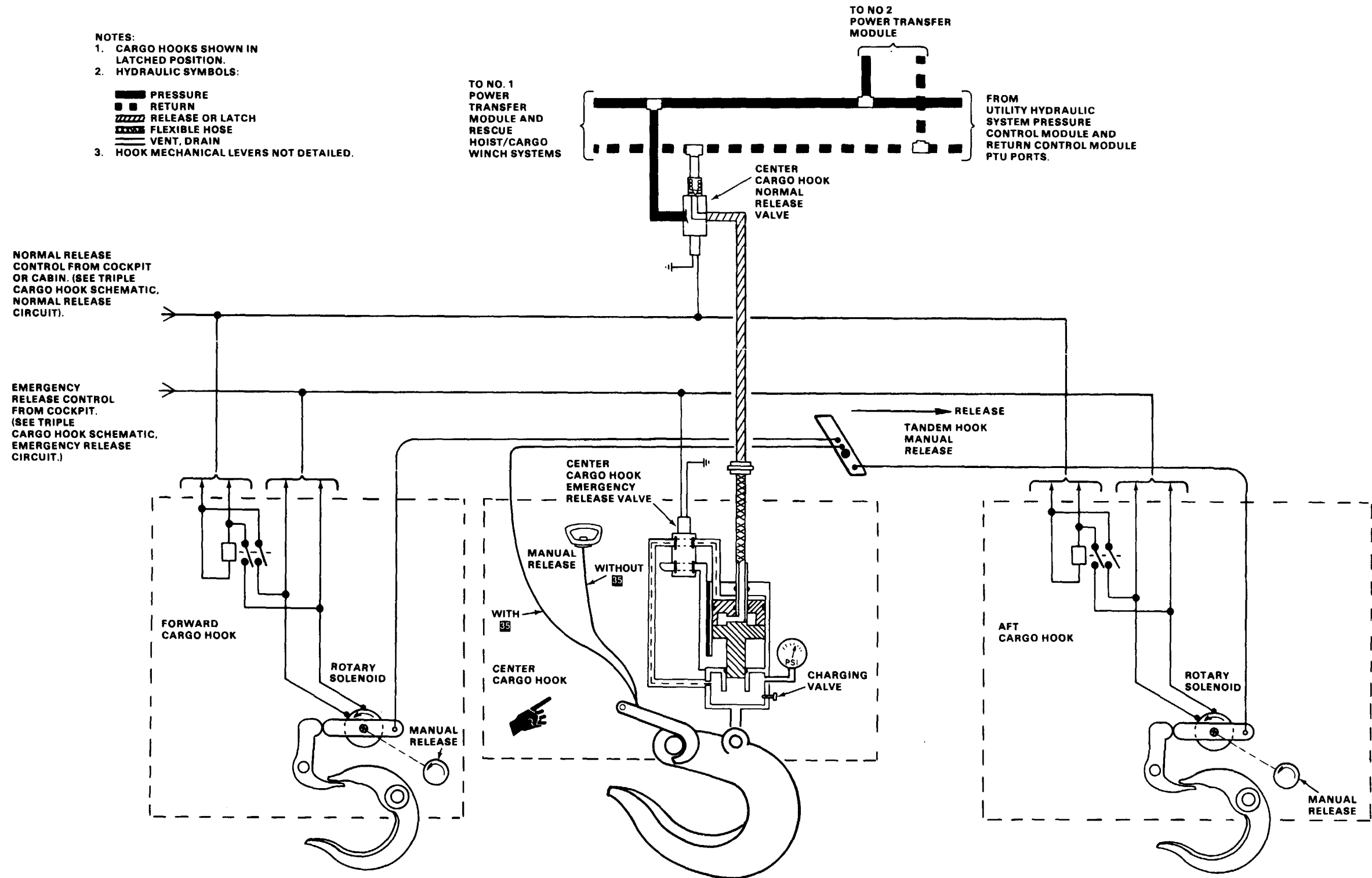

17323

16-1.1 EXTERNAL CARGO HOOK SYSTEM SCHEMATIC - NORMAL RELEASE MODE (Continued)

WITHOUT 74 

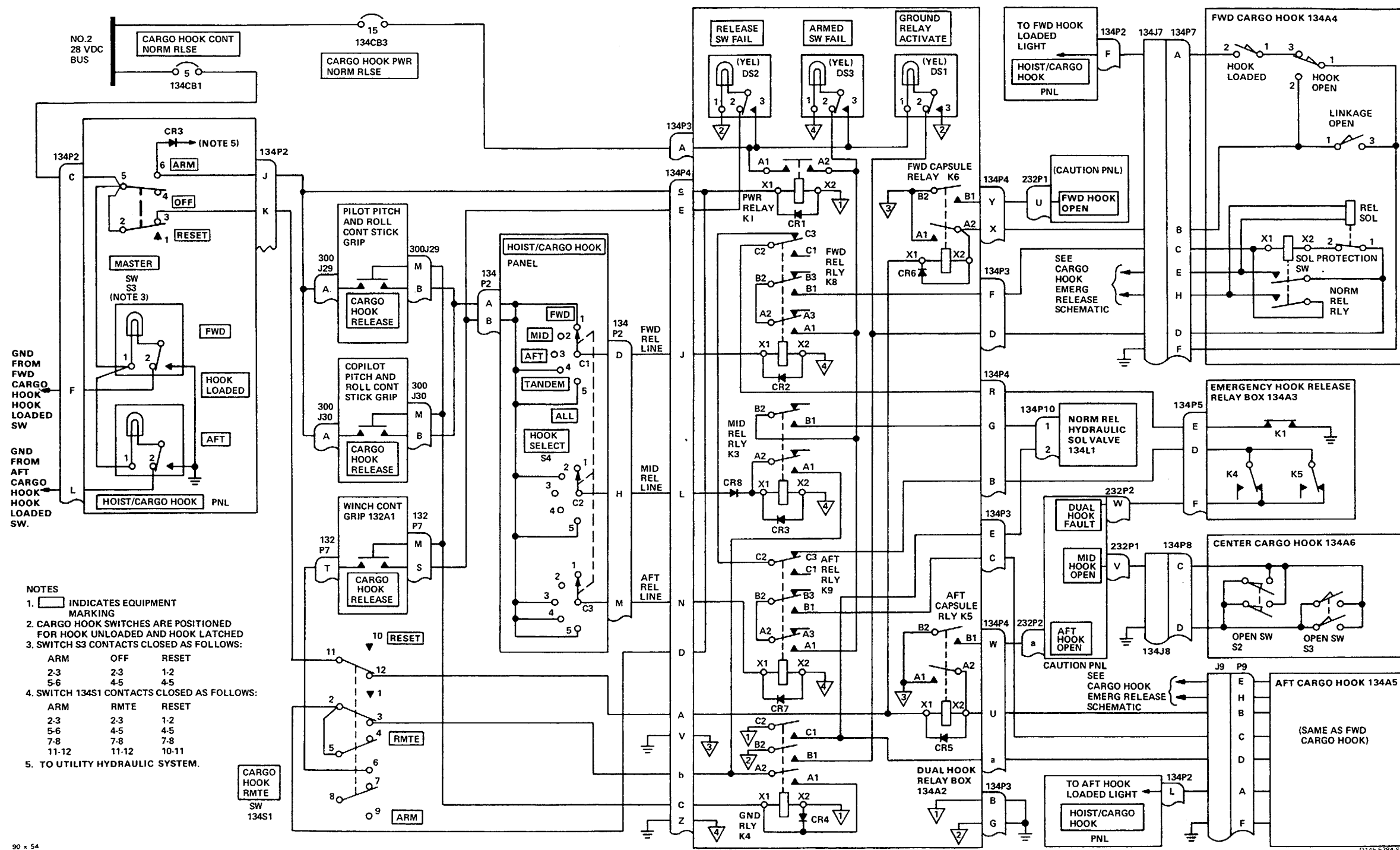

- NOTES
- INDICATES EQUIPMENT MARKING
 - CARGO HOOK SWITCHES ARE POSITIONED FOR HOOK UNLOADED AND HOOK LATCHED
 - SWITCH S3 CONTACTS CLOSED AS FOLLOWS:

ARM	OFF	RESET
2-3	2-3	1-2
5-6	4-5	4-5
 - SWITCH 134S1 CONTACTS CLOSED AS FOLLOWS:

ARM	RMTE	RESET
2-3	2-3	1-2
5-6	4-5	4-5
7-8	7-8	7-8
11-12	11-12	10-11
 - TO UTILITY HYDRAULIC SYSTEM.

GO TO NEXT PAGE

Change 23 16-2.9

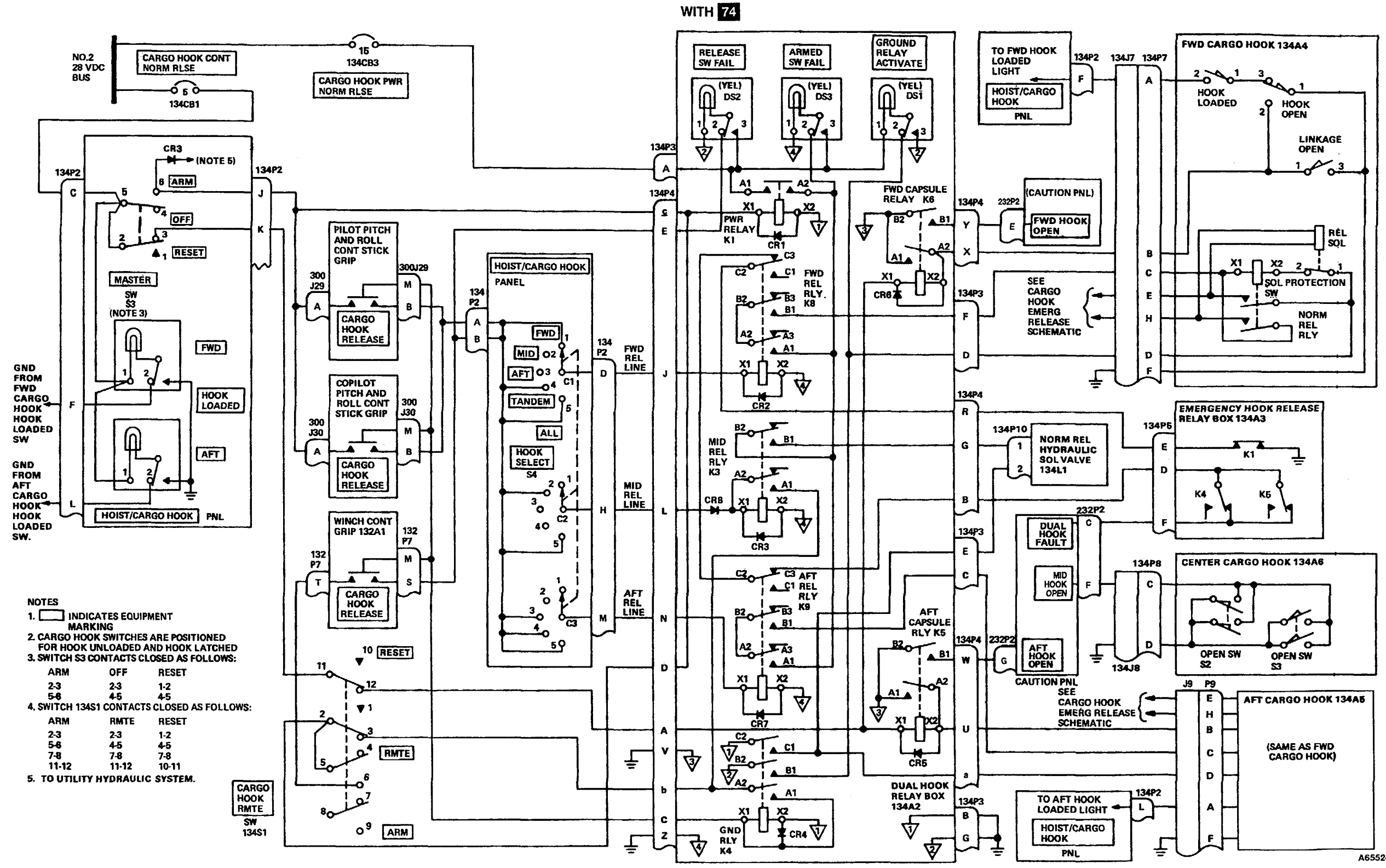

16-1.1 EXTERNAL CARGO HOOK SYSTEM SCHEMATIC - EMERGENCY RELEASE MODE

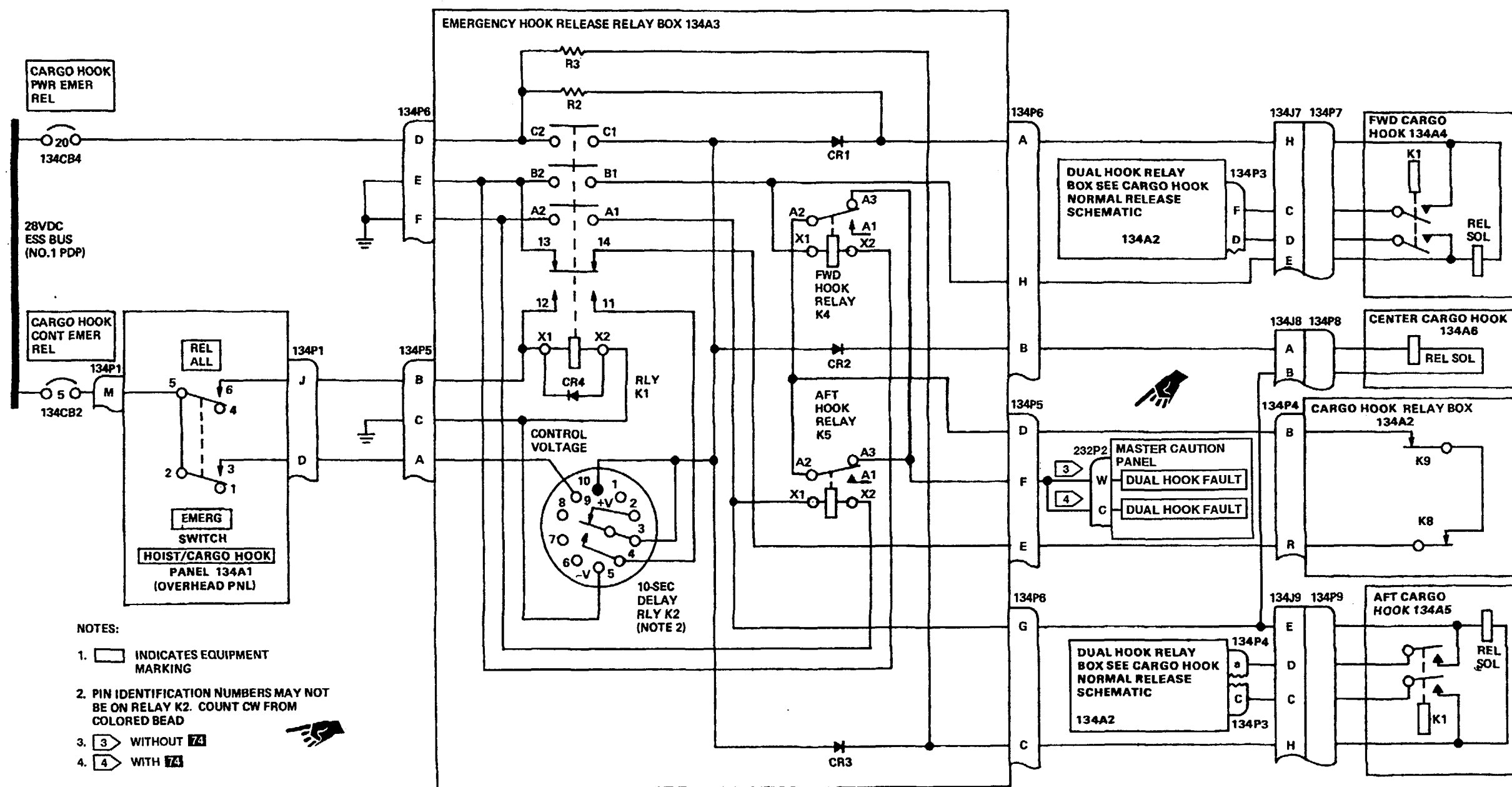

- NOTES:
1. INDICATES EQUIPMENT MARKING
 2. PIN IDENTIFICATION NUMBERS MAY NOT BE ON RELAY K2. COUNT CW FROM COLORED BEAD
 3. WITHOUT 74
 4. WITH 74

A65523

16-1.2 EXTERNAL CARGO HOOK SYSTEM WIRING DIAGRAM

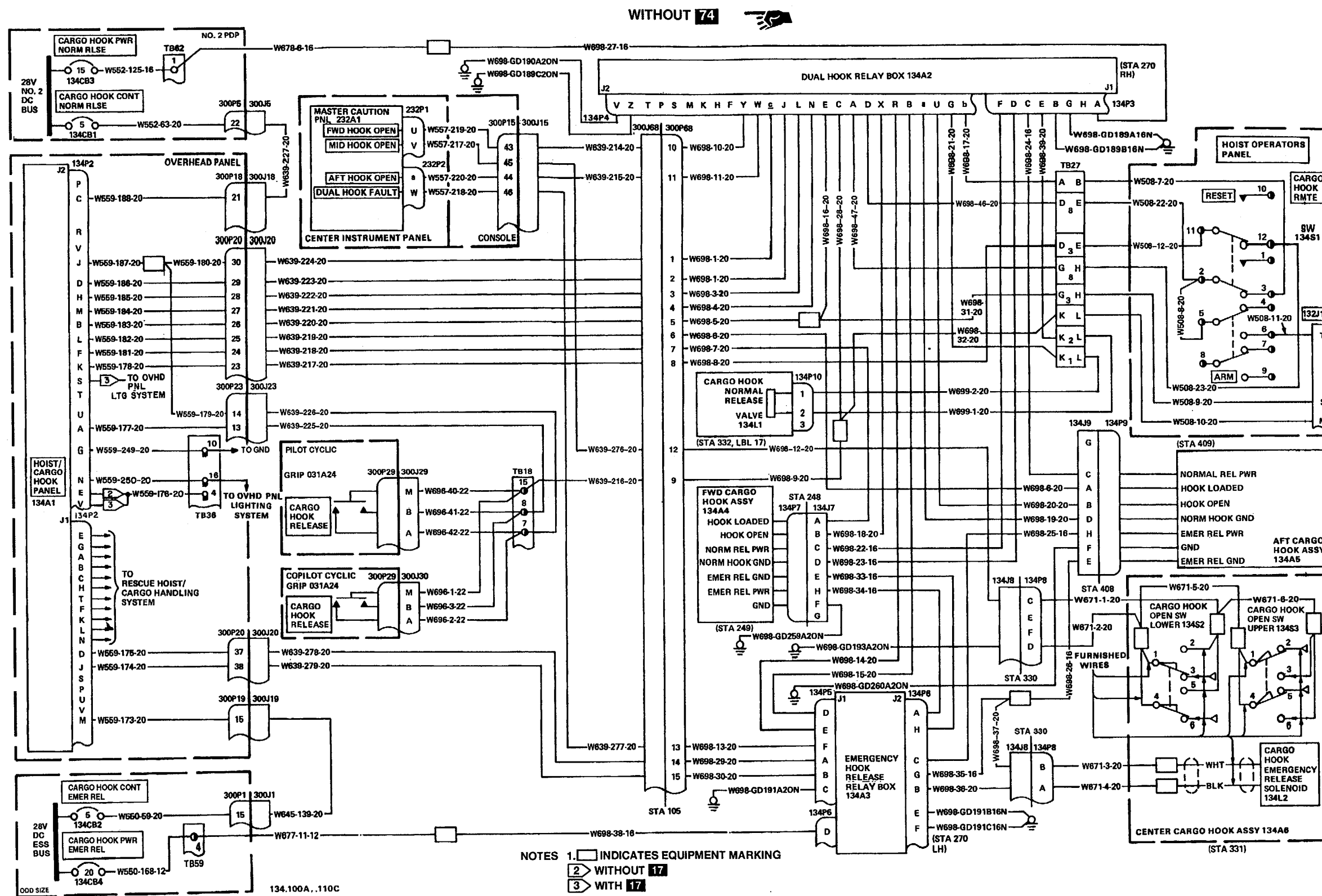

A10223

16-1.2 EXTERNAL CARGO HOOK SYSTEM WIRING DIAGRAM (Continued)

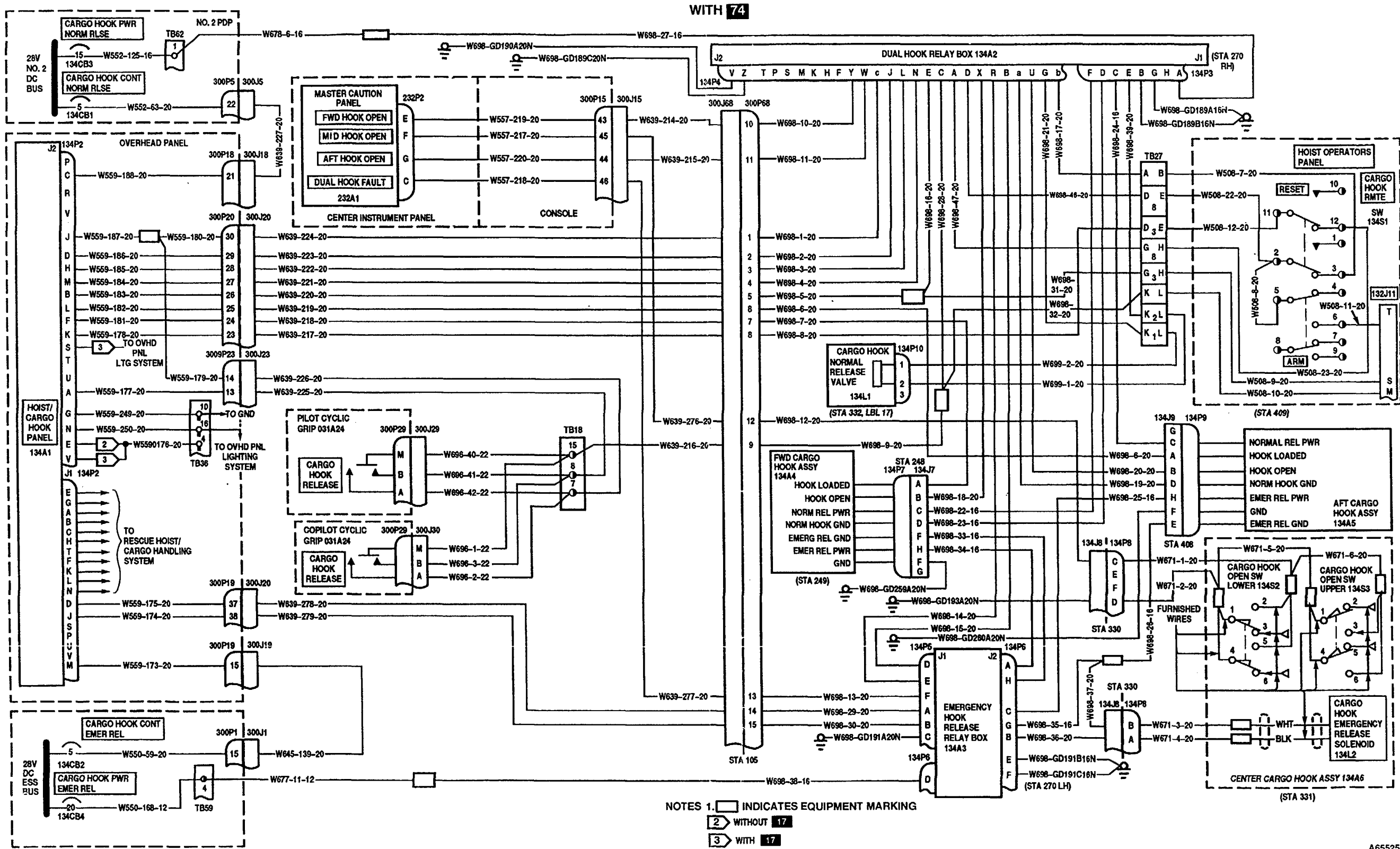

A65525

16-1.3 EXTERNAL CARGO HOOK SYSTEM VISUAL CHECK

16-1.3

INITIAL SETUP

Applicable Configurations:

All

Tools:

Aircraft Mechanic's Tool Kit.
NSN 5180-00-323-4692

Materials:

None

Personnel Required:

67U20 Medium Helicopter Repairer

References:

TM 55-1520-240-23

Equipment Condition:

TM 55-1520-240-23:
Battery Disconnected
Electrical Power Off
Hydraulic Power Off
Center Cargo Hook Access Panel Open
Center Cargo Hook Unstowed
Center Tunnel Cover Open

TASK	RESULT
1. Check forward cargo hook (1).	If load beam (2) is open, close it. If it does not stay closed check rigging of tandem hook release rigging. Adjust as required (TM 55-1520-240-23). If rigging is okay and load beam is still open, replace cargo hook. If control assembly (3) is damaged, replace it. If keeper (4) is damaged, replace it. If wire harness (5) is damaged replace it. If window (6) is damaged, replace it.
2. Repeat step (1) for aft cargo hook (7).	
3. Check center cargo hook (8).	If hook (9) is open, close it. If it does not stay closed service cargo hook actuator and check manual release cams (TM 55-1520-240-23). If hook still can not be closed, replace cargo hook (8). If keeper (10) is forward of hook (9) or damaged, adjust or replace it. If release mechanism (11) is damaged, replace it. If wire harness or hydraulic hose (12 or 13) is damaged, replace it.

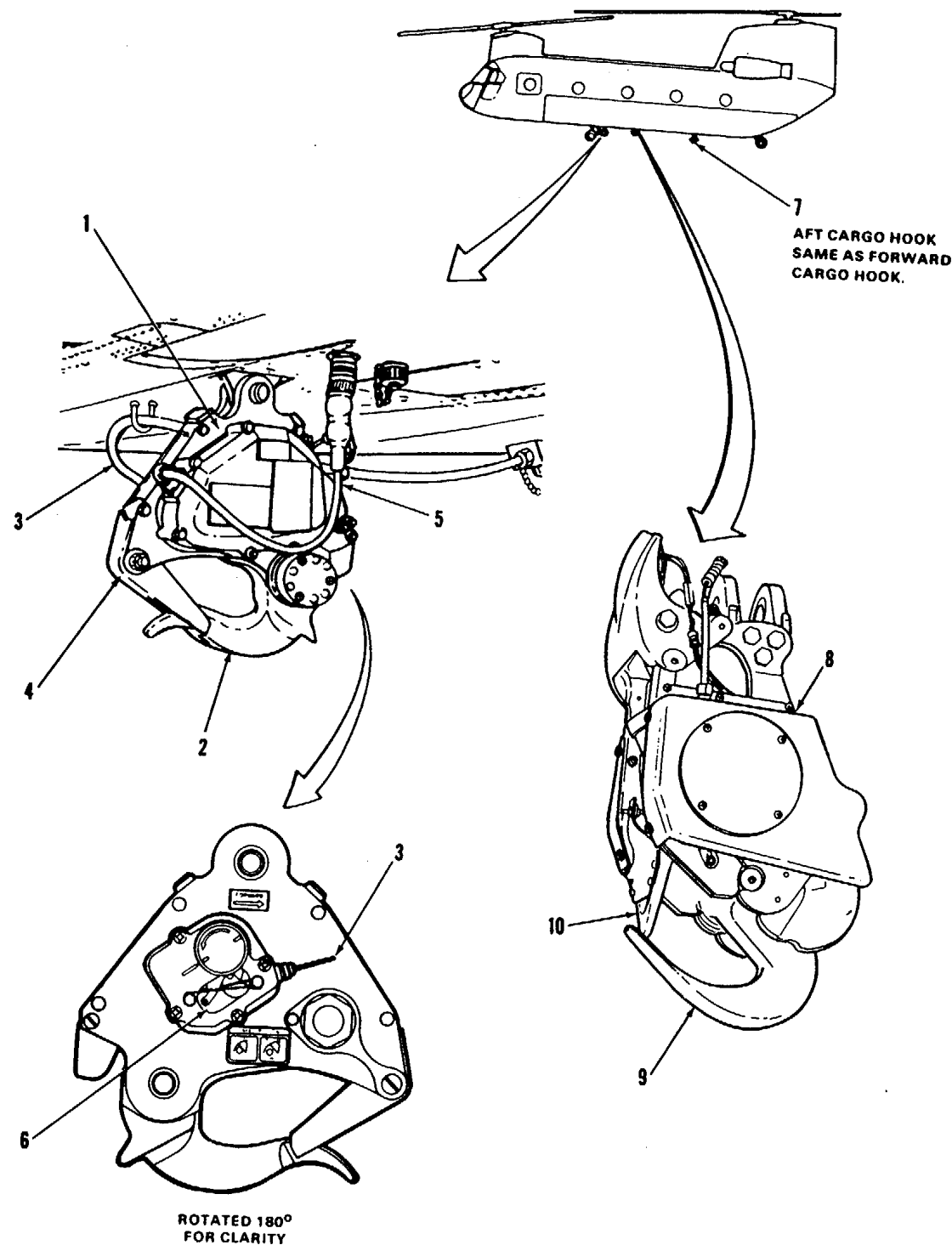

4554

D145-6342-SPA

16-1.3 EXTERNAL CARGO HOOK SYSTEM VISUAL CHECK
(Continued)

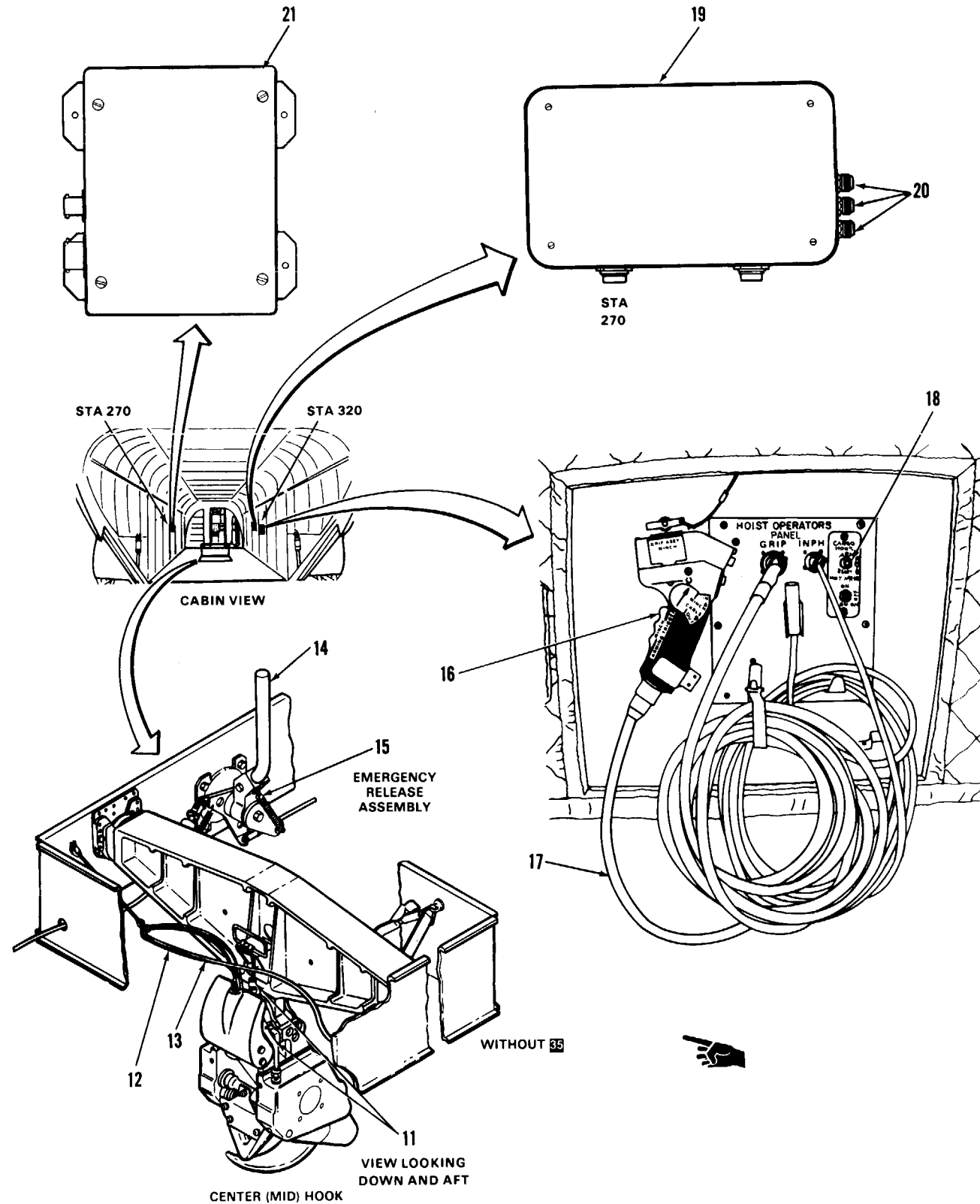

TASK	RESULT
4. Lift emergency cargo hook release lever (14) from stowed position. Check lever mechanism (15).	If lever (14) or any part of mechanism (15) is loose or damaged, tighten or replace it as required
5. Check hoist operator's grip (16) and cable assembly (17).	If grip (16) is damaged, replace it. If cable assembly (17) is damaged, replace it.
6. Check CARGO HOOK switch (18).	If switch (18) is loose or damaged, tighten or replace it as required.
7. Check dual hook relay box (19).	If box (19) is loose or damaged, tighten or replace it as required. If wiring or connectors to box are damaged, repair or replace them as required. If any light (20) is damaged, replace box.
8. Check emergency hook release relay box (21).	If box (21) is loose or damaged, tighten or replace it as required. If wiring or connectors to box are damaged, repair or replace them as required,

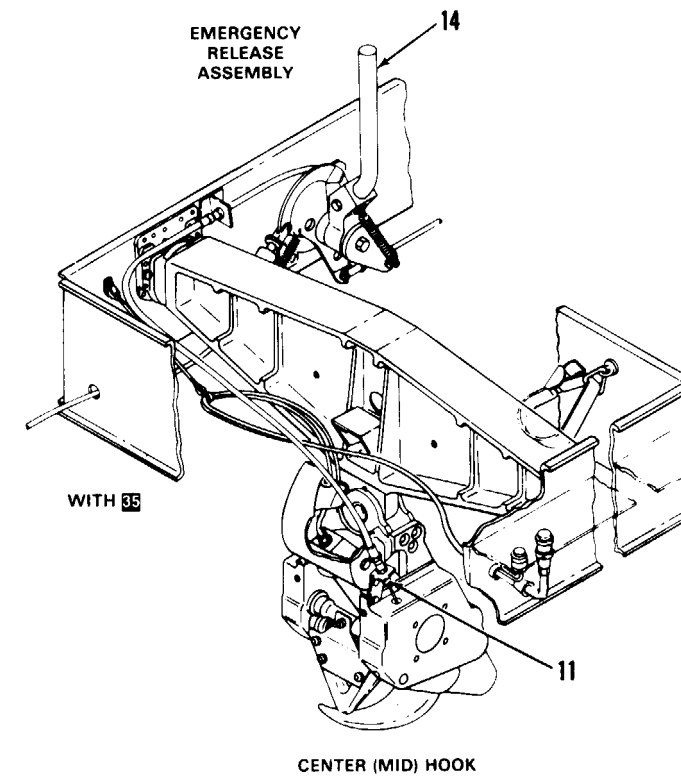

17328

GO TO NEXT PAGE

16-1.3 EXTERNAL CARGO HOOK SYSTEM VISUAL CHECK
(Continued)

TASK	RESULT
9. Check HOIST/CARGO HOOK panel (22).	If switch (23 or 24), knob (25), or light (26 or 27) is loose or damaged, replace panel (22).
10. Check cargo hook normal release valve (28).	If valve (28) is loose or damaged, tighten or replace it. If wiring or connector to valve is damaged, repair or replace it as required.

FOLLOW-ON MAINTENANCE:

TM 55-1520-240-23:
Close center tunnel cover.

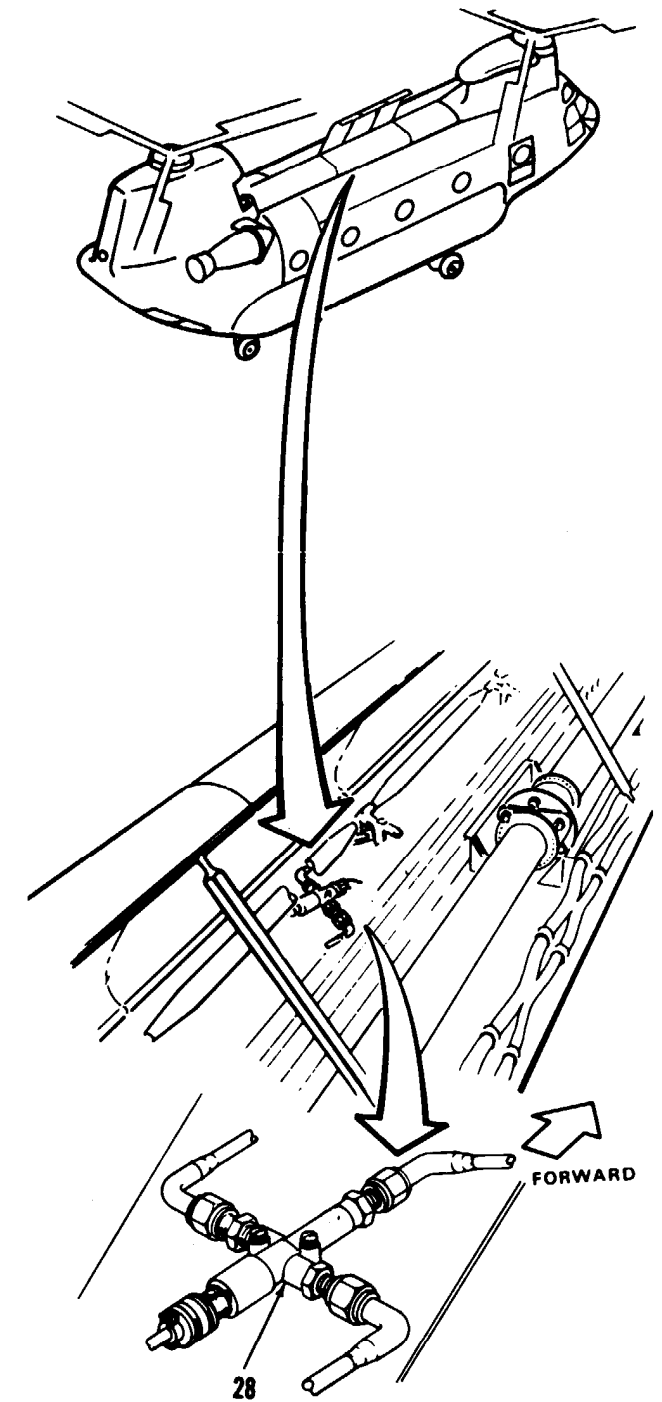
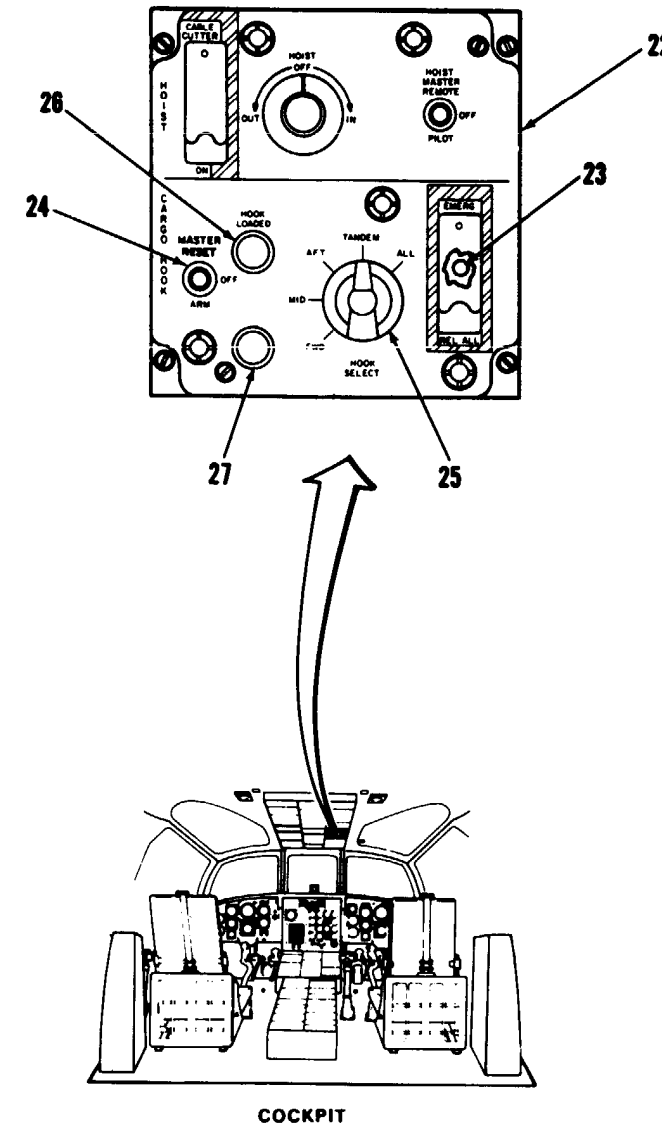

16-1.4 EXTERNAL CARGO HOOK SYSTEM OPERATIONAL CHECK

INITIAL SETUP

Applicable Configurations:

- All
- Tools:**
 - Rope, 15 Foot
 - Without **35** Load 20-25 Pounds (3)
 - With **35** Load, 20-25 Pounds (2) Fwd and Aft Hook
 - Load, 45-50 Pounds (1) Center Hook
 - Wood Plank, 2-Inches x 4-Inches x 4-Feet
 - Dial Indicating Scale, 0 to 50 Pounds
 - Stopwatch
 - Inspection Mirror

Materials:
None

Personnel Required:

Medium Helicopter Repairer (2)

References:

TM 55-1520-240-23

Equipment Condition:

- TM 55-1520-240-23:
- Battery Connected
- Electrical Power On
- Hydraulic Power On
- Visual Check Of External Cargo Hook System Performed (Task 16-1.3)
- Area Beneath Three Cargo Hooks Clear Of Obstructions

TASK	RESULT
1. Check that MASTER switch (1) is OFF.	If switch (1) is not OFF, set it to OFF.
2. Check that HOOK SELECT switch (2) is at FWD.	If switch (2) is not at FWD, set it to FWD.
3. Check that switch guard (3) over EMERG switch is down.	If switch guard (3) is up, close it.
4. Check that CARGO HOOK switch (4) is at RMTE.	If switch (4) is not at RMTE, set it to RMTE.
5. Check FWD and AFT HOOK LOADED LIGHT lights (5 and 6) .	Both lights (5 and 6) shall be out. If either light is on, go to Task 16-1.5.
6. Press and release FWD HOOK LOADED light (5) .	Light (5) shall momentarily come on. If it does not, go to Task 16-1.6.
7. Press and release AFT HOOK LOADED light (6) .	Light (6) shall momentarily come on. If it does not, go to Task 16-1.6.
8. Check that CARGO HOOK EMR REL PWR and CONT circuit breakers (7 and 8) are closed.	If CARGO HOOK EMER REL PWR or CONT circuit breaker (7 or 8) is open, close it. If EMERG REL PWR circuit breaker (7) opens again, go to Task 16-1.7. If EMER REL CONT circuit breaker (8) opens again, go to Task 16-1.8.
9. Check that CARGO HOOK NORM RLSE PWR and CONT circuit breakers (9 and 10) are closed.	If CARGO HOOK NORM RLSE PWR or CONT circuit breaker (9 or 10) is open, close it. If NORM RLSE PWR circuit breaker (9) opens again, go to Task 16-1.9. If NORM RLSE CONT circuit breaker (10) opens again, go to Task 16-1.10.

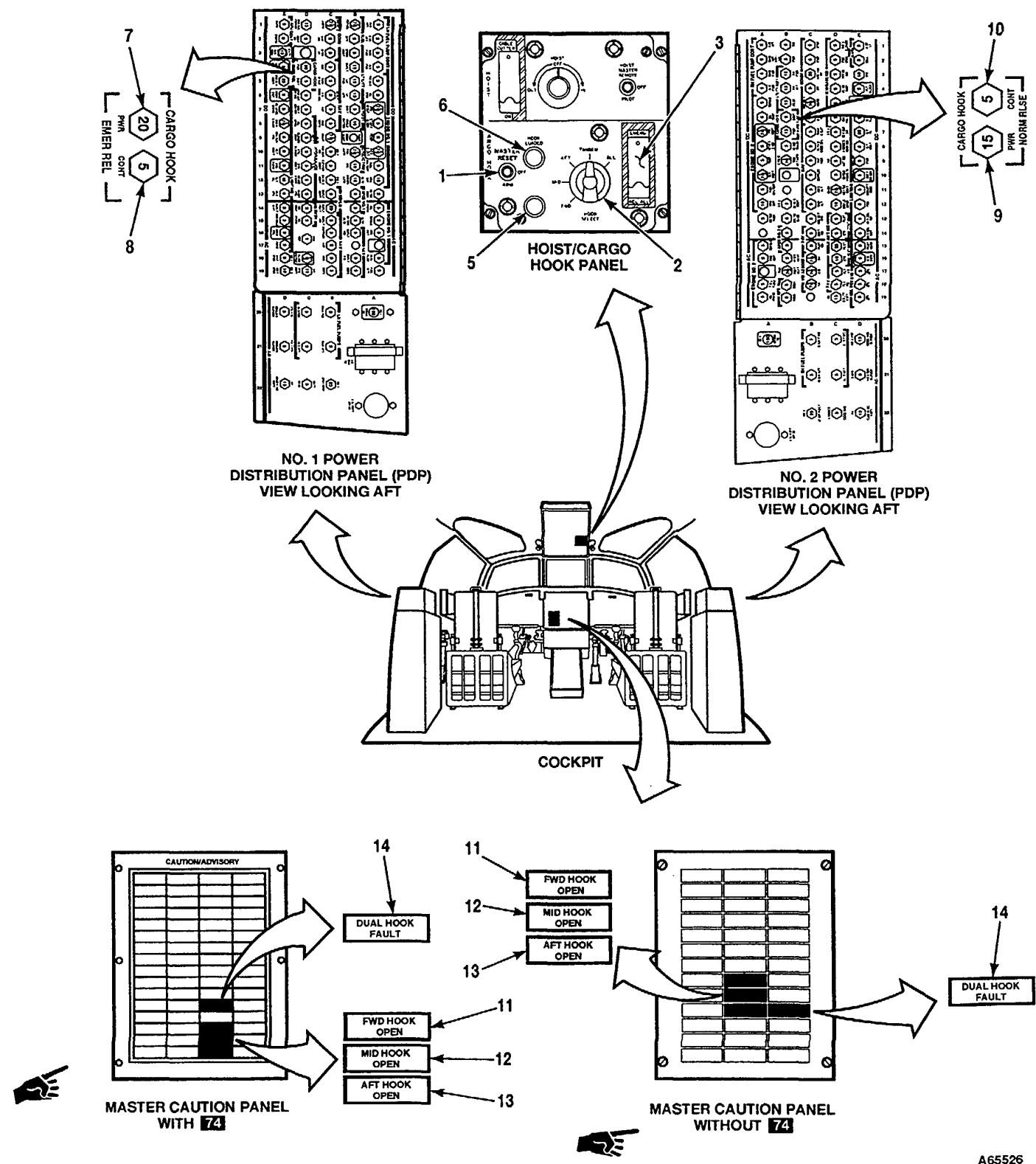

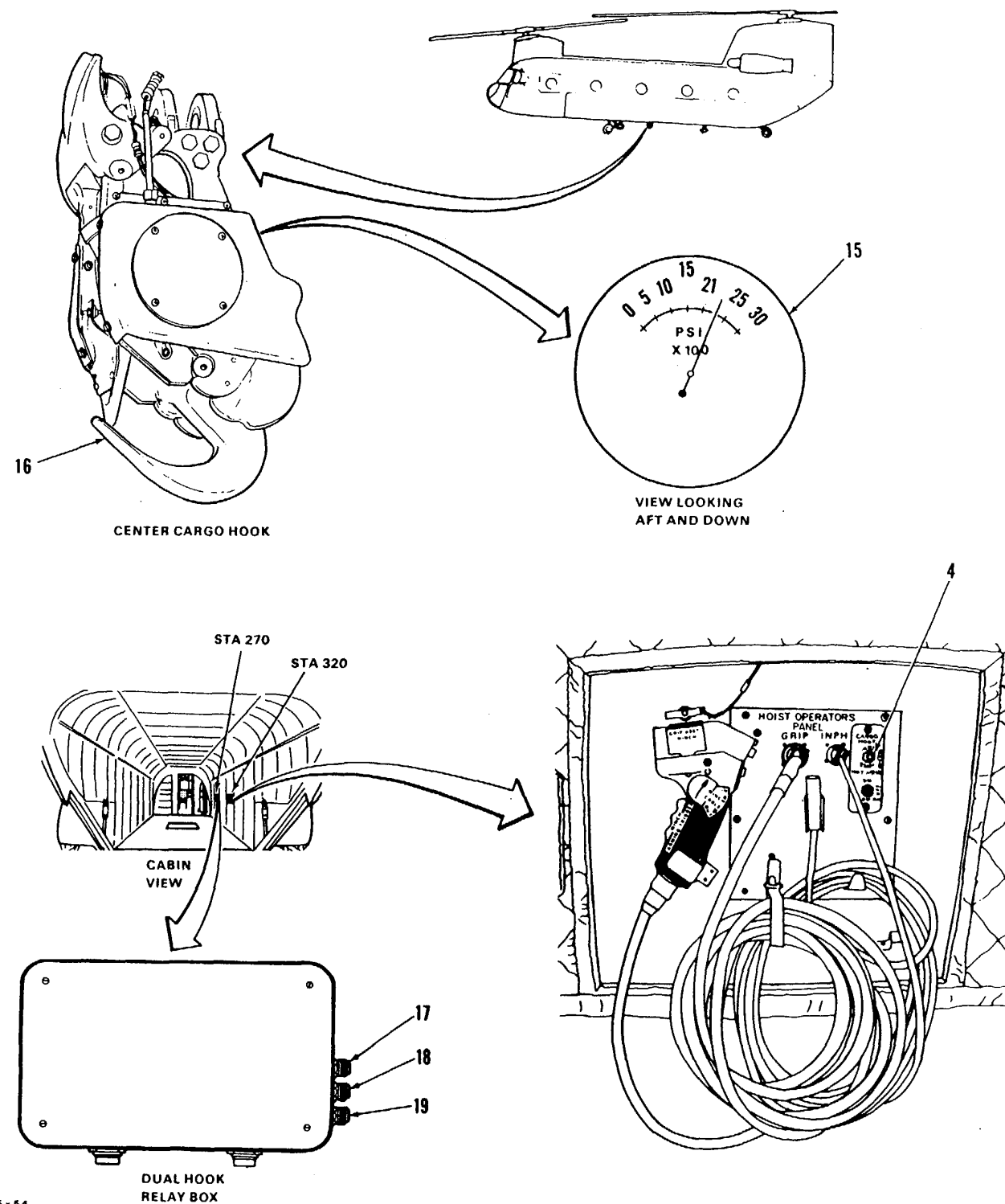

TASK

RESULT

10. Check FWD HOOK OPEN, MID HOOK OPEN, AFT HOOK OPEN, and DUAL HOOK FAULT capsules (11, 12, 13, and 14).

If FWD HOOK OPEN capsule (11) is lit, go to task 16-1.11. If MID HOOK OPEN capsule (12) is lit, go to task 16-1.12. If AFT HOOK OPEN capsule (13) is lit, go to task 16-1.13. If DUAL HOOK FAULT capsule (14) is lit, go to task 16-1.14.

11. Check center cargo hook gage (15).

Gage shall indicate at least 2100 psi. If it does not, service center cargo hook actuator (TM 55-1520-240-23).

WARNING

If gage indication is below 2100 psi, inadvertent cargo hook operation could occur resulting in loss of external load. Injury or death can occur to personnel.

12. Press down on hook (16) on center cargo hook. Use wood plank.

Hook (16) on center cargo hook shall not move to open position. If it does, replace center cargo hook.

WARNING

If a status light is on, it indicates that a first failure has occurred in one of the redundant protective circuits. A second failure while the system is in this condition can result in loss of external loads, resulting in personnel injury or death.

13. Check ARMED SW FAIL status light (17).

Light (17) shall be out. If it is on, replace HOIST/CARGO HOOK panel.

14. Press and release ARMED SW FAIL, RELEASE SW FAIL, and GROUND RE LAY ACTIVATE lights (17, 18 and 19).

Lights (17, 18 and 19) shall come on when pressed and go out when released. If any light does not come on, go to task 16-1.15.

16-1.4 EXTERNAL CARGO HOOK SYSTEM OPERATIONAL CHECK (Continued)

TASK	RESULT
15. Disconnect forward cargo hook connector (20).	DUAL HOOK FAULT capsule (14) shall come on. If it does not, go to Task 16-1.16.
16. Set MASTER switch (1) to ARM.	ARMED SW FAIL light (17) shall come on. If it does not, go to Task 16-1.17.
17. Press and release pilot's CARGO HOOK RELEASE switch (21).	RELEASE SW FAIL light (18) shall momentarily come on. GROUND RELAY ACTIVATE light (19) shall come on and stay on. If either or both lights do not come on, go to Task 16-1.18.
18. Set MASTER switch (1) to OFF and then back to ARM.	ARMED SW FAIL light (17) shall go out and come back on. GROUND RELAY ACTIVATE light (19) shall go out. If both lights stay on, replace HOIST/CARGO HOOK Panel.
19. Press and release CARGO HOOK RELEASE switch (21) on copilot's pitch and roll control grip.	RELEASE SW FAIL light (18) shall momentarily come on. GROUND RELAY ACTIVATE light (19) shall come on and stay on. If either light does not come on, go to Task 16-1.19.
20. Repeat step 18, then go to step 21.	
21. Press and release CARGO HOOK RELEASE switch (22).	RELEASE SW FAIL light (18) and GROUND RELAY ACTIVATE light (19) shall stay out. If either light comes on, replace CARGO HOOK switch (4).
22. Set CARGO HOOK switch (4) to ARM.	
23. Press and release CARGO HOOK RELEASE switch (22).	RELEASE SW FAIL light (18) shall momentarily come on. GROUND RELAY ACTIVATE light (19) shall come on and stay on. If either light does not come on, go to Task 16-1.20.
24. Set CARGO HOOK switch (4) to RESET then to RMTE.	GROUND RELAY ACTIVATE light (19) shall go out. If it does not, replace CARGO HOOK switch (4).

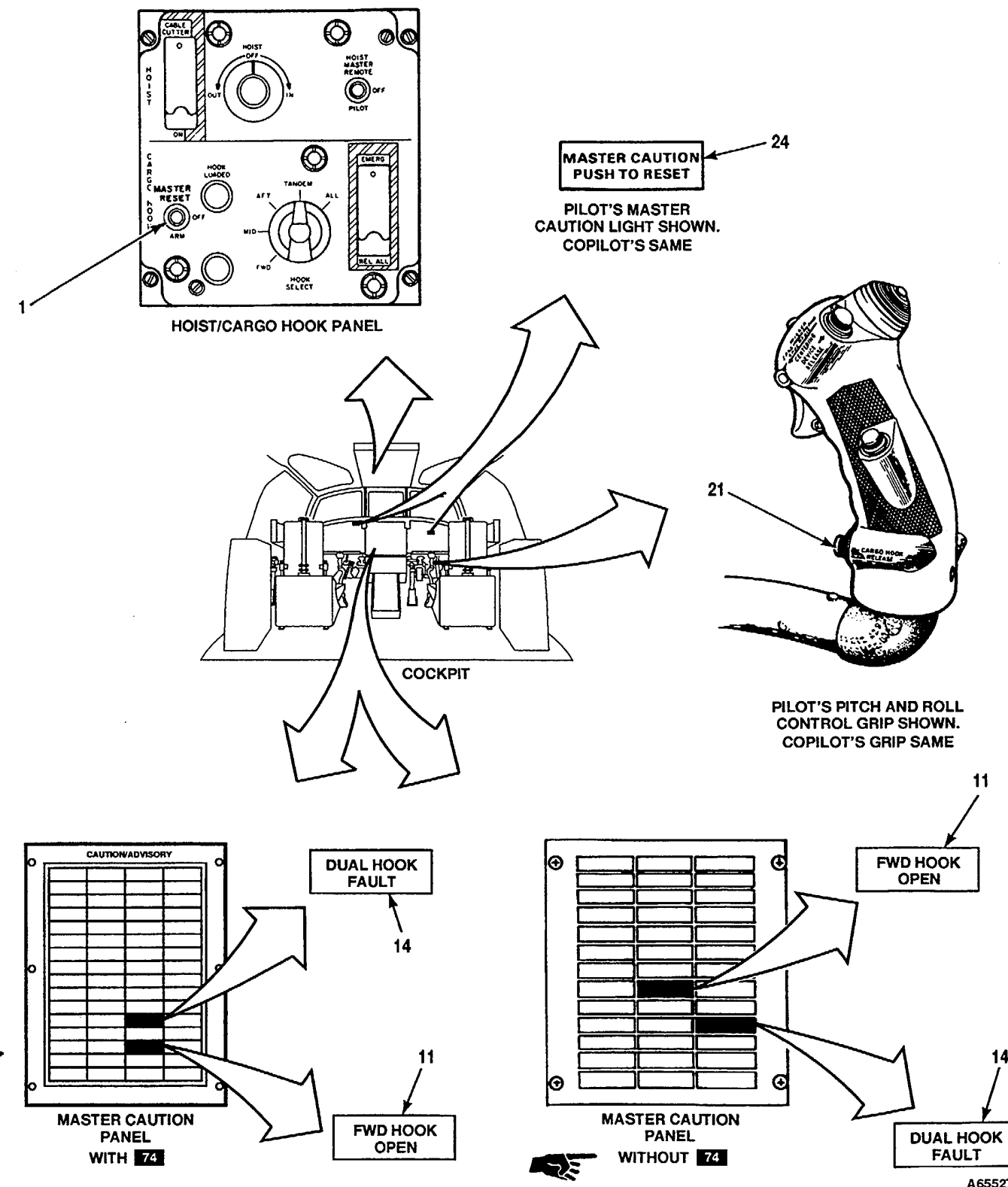

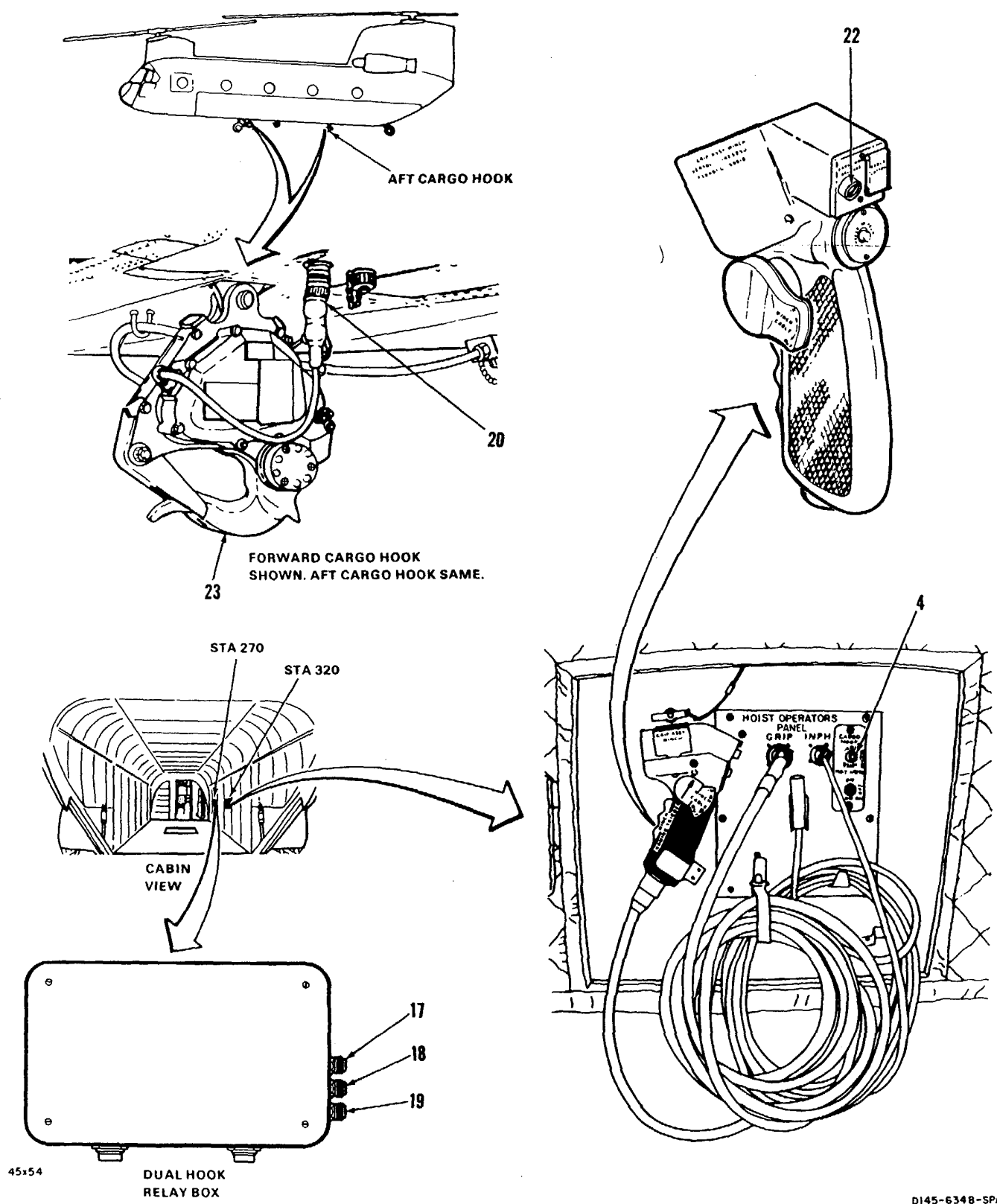

45x54 DUAL HOOK RELAY BOX

D145-6348-SPA

TASK	RESULT
25. Set MASTER switch (1) to RESET then to OFF.	
26. Connect forward cargo hook connector (20) to fuselage receptacle.	DUAL HOOK FAULT capsule (14) shall go out.
27. Disconnect aft cargo hook connector (20).	DUAL HOOK FAULT capsule (14) shall come on. If it does not, replace emergency hook release relay box.
28. Connect aft cargo hook connector (20) to fuselage receptacle.	DUAL HOOK FAULT capsule (14) shall go out.
29. Set MASTER switch (1) to ARM.	
30. Suspend one 20-25 pound load to each load beam (23) on forward and aft cargo hooks.	
31. Press and release pilot's CARGO HOOK RELEASE switch (21).	Forward cargo hook shall open and drop load then relatch closed. FWD HOOK OPEN capsule (11) shall come on. Pilot and copilot master caution lights (24) shall come on. If forward cargo hook does not open will go to task 16-1.21. If hook opens and FWD HOOK OPEN capsule does not come on, go to task 16-1.22.
<p>NOTE If CARGO HOOK RELEASE switch is held pressed, a hammering sound be heard from forward cargo hook.</p>	
32. Set MASTER switch (1) to RESET, then to ARM.	Forward cargo hook shall stay closed. FWD HOOK OPEN capsule (11) shall go out. Pilot and copilot master caution lights (24) shall go out. If capsule is still lit, go to task 16-1.11. If lights (24) are still lit, replace master caution panel.
33. Suspend one 20-25 pound load to load beam (23) on forward cargo hook.	

16-1.4 EXTERNAL CARGO HOOK SYSTEM OPERATIONAL CHECK (Continued)

TASK	RESULT
34. Set HOOK SELECT switch (2) to MID.	
35. Press and release pilot's CARGO HOOK RELEASE switch (21).	Center cargo hook shall open and remain open. MID HOOK OPEN capsule (12) shall come on. Pilot and copilot master caution lights (24) shall come on. If center cargo hook does not open, go to Task 16-1.23. If hook opens and MID HOOK OPEN capsule does not come on, go to Task 16-1.24.
36. Set MASTER switch (1) to RESET then to ARM.	Center cargo hook shall close and remain closed. MID HOOK OPEN capsule (12) shall go out. Pilot and copilot master caution lights (24) shall go out. If center cargo hook does not close, replace it. If capsule is still lit when center cargo hook closed, go to Task 16-1.12.
37. Set HOOK SELECT switch (2) to AFT.	
38. Press and release pilot's CARGO HOOK RELEASE switch (21).	Aft cargo hook shall open and drop load then relatch closed. AFT HOOK OPEN capsule (13) shall come on. Pilot and copilot master caution lights (24) shall come on. If aft cargo hook does not open, go to Task 16-1.25. If hook opens and AFT HOOK OPEN capsule does not come on, go to Task 16-1.26.
39. Set MASTER switch (1) to RESET then to ARM.	Aft cargo hook shall stay closed. AFT HOOK OPEN capsule (13) shall go out. Pilot and copilot master caution lights (24) shall go out. If capsule is still lit, go to Task 16-1.13.

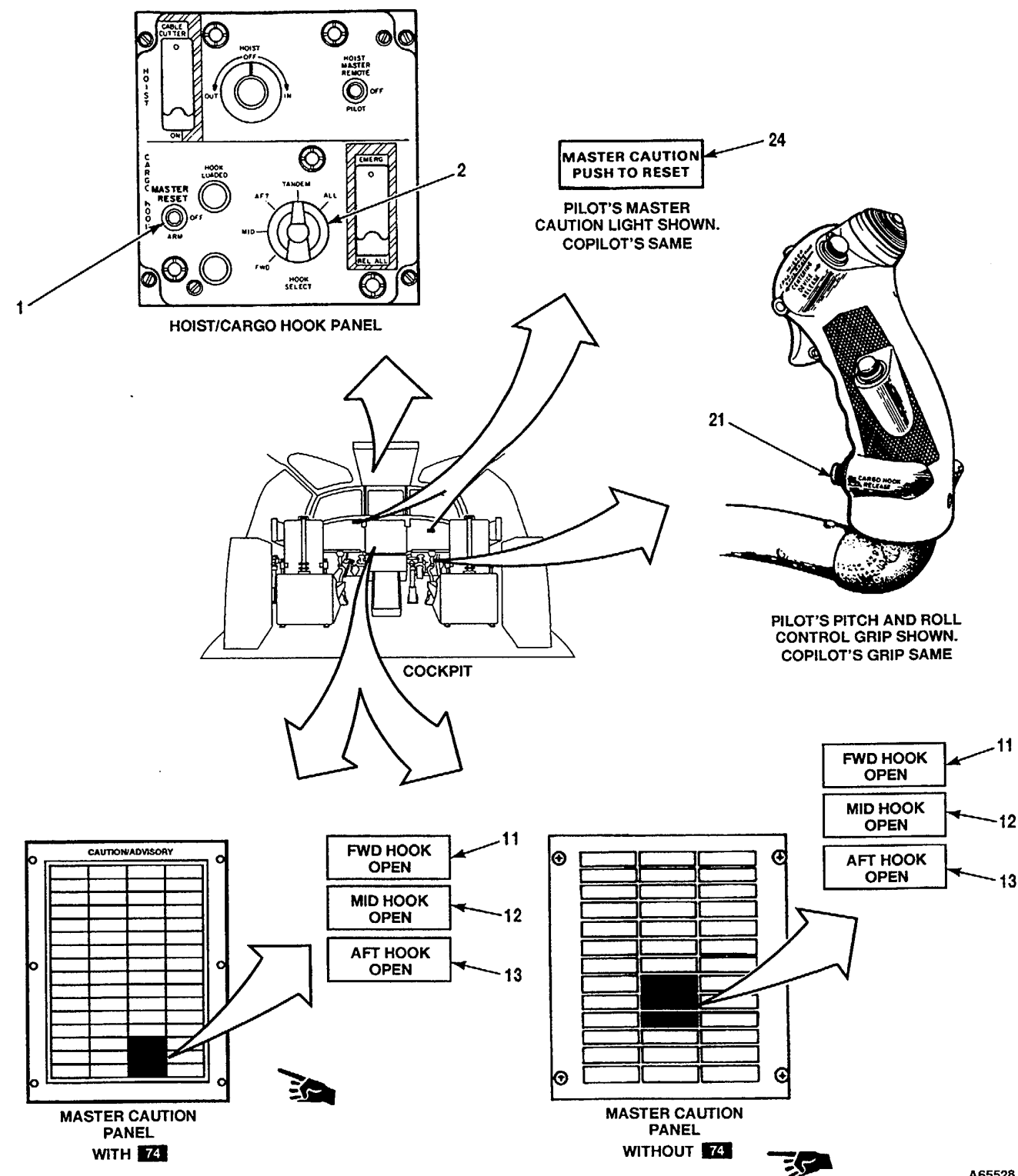

16-1.4 EXTERNAL CARGO HOOK SYSTEM OPERATIONAL CHECK (Continued)

TASK	RESULT
40. Suspend 20-25 pound load from load beam (23) on aft cargo hook.	
41. Set HOOK SELECT switch (2) to TANDEM.	
42. Press and release pilot's CARGO HOOK RELEASE switch (21).	Forward and aft cargo hooks shall open and drop load then relatch closed. FWD HOOK OPEN and AFT HOOK OPEN capsules (11 and 13) shall come on. Pilot and copilot's master caution lights (24) shall come on. If both hooks do not open, replace HOIST/CARGO HOOK panel.
43. Set CARGO HOOK switch (4) to RESET and then to RMTE.	Forward and aft cargo hooks shall stay closed. FWD HOOK OPEN and AFT HOOK OPEN capsules (11 and 13) shall go out. If capsules are still on, replace CARGO HOOK switch (4).
44. Suspend one 20-25 pound load from each load beam (23) on forward and aft cargo hooks.	
45. Set HOOK SELECT switch (2) to ALL.	
46. Press and release pilot's CARGO HOOK RELEASE switch (21).	Forward and aft cargo hooks shall open and drop loads then relatch closed. Center cargo hook shall open and stay open. FWD HOOK OPEN, MID HOOK OPEN, and AFT HOOK OPEN capsules (11, 12 and 13) shall come on. Pilot and copilot master caution lights (24) shall come on. If all hooks do not open, replace HOIST/CARGO HOOK panel.

Note

It is normal for MID HOOK OPEN capsule to come on at 2 to 3 seconds after FWD HOOK OPEN and AFT HOOK OPEN capsules come on.

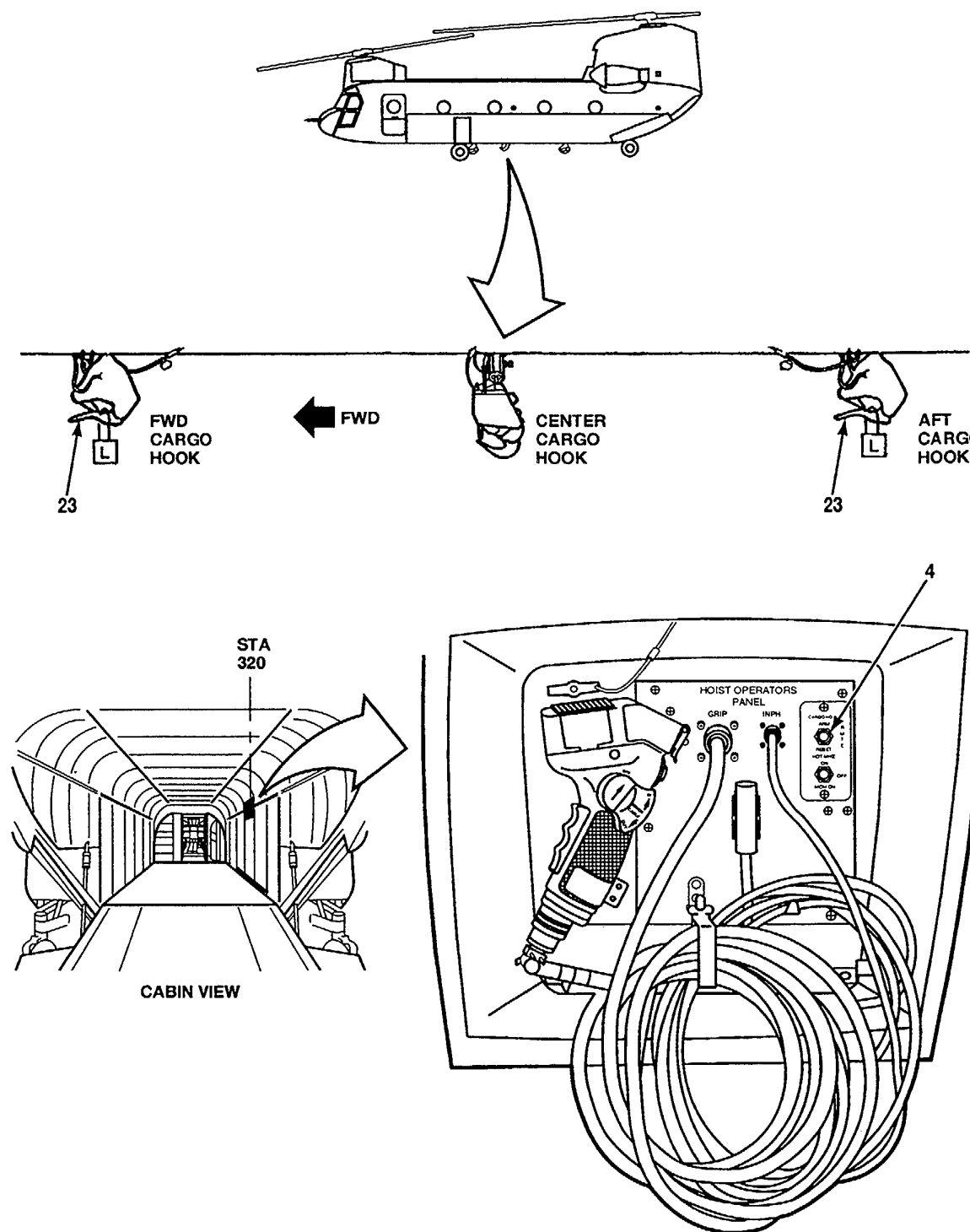

A17324

GO TO NEXT PAGE
Change 23 16-15

16-1.4 EXTERNAL CARGO HOOK SYSTEM OPERATIONAL CHECK (Continued)

TASK	RESULT
------	--------

47. Set MASTER switch (1) to RESET, then to OFF.	Forward and aft cargo hooks shall remain closed. Center cargo hook shall close and remain closed. FWD HOOK OPEN, MID HOOK OPEN, and AFT HOOK OPEN capsules (11, 12 and 13) shall go out. Pilot and copilot master caution lights (24) shall go out.
--	---

48. Suspend one 20-25 pound load from each load beam (23) on forward and aft cargo hooks.	
49. Check center cargo hook gage (15).	Gage (15) shall indicate at least <u>2100 psi</u> . If it does not, service center cargo hook actuator (TM 55-1520-240-23).

WARNING

- If gage indication is below 2100 psi, inadvertent cargo hook operation could occur resulting in loss of external load. Injury or death to personnel can occur.
- Do not stand near center cargo hook when EMERG switch is set to REL ALL. High pressure air, possibly mixed with oil, will be vented from cargo hook. Injury to personnel can occur.

50. Lift switchguard over EMERG switch (3). Momentarily set EMERG switch to REL ALL.	
--	--

All cargo hooks shall open and following shall occur for 10 to 14 seconds: Forward and aft cargo hook load beams (23) shall open, drop loads and then close. Center cargo hook shall remain open. FWD HOOK OPEN, MID HOOK OPEN, and AFT HOOK OPEN capsules (11, 12 and 13) shall come on and pilot and copilot master caution lights (24) shall come on.

Center cargo hook shall close after 10 to 14 seconds. The MID HOOK OPEN capsule (12) shall go out. If any cargo hook does not open, go to Task 16-1.27. If center cargo hook opens but does not stay open for 10 to 14 seconds, go to Task 16-1.28.

Capsules (11 and 13) and lights (24) shall go out.

50.1 Set MASTER switch (1) to RESET, then to OFF.	
---	--

51. Close switchguard over EMERG switch (3).	
--	--

52. Without 35 service center cargo hook actuator (TM 55-1520-240-23). Suspend 20-25 pound load to tongue (16) on center cargo hook.	
---	--

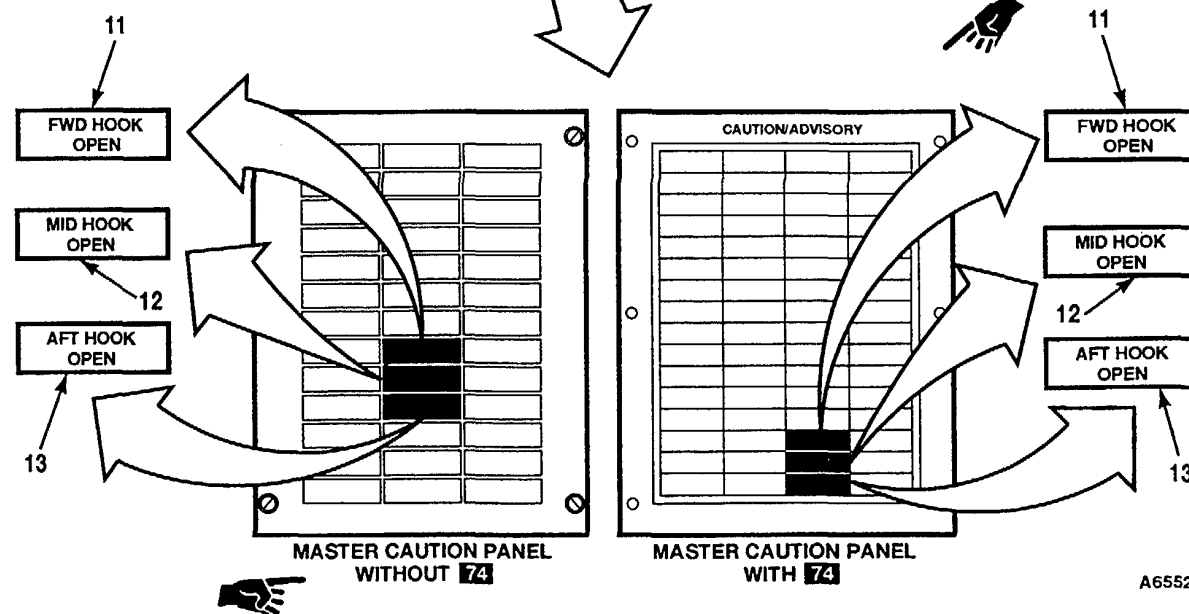
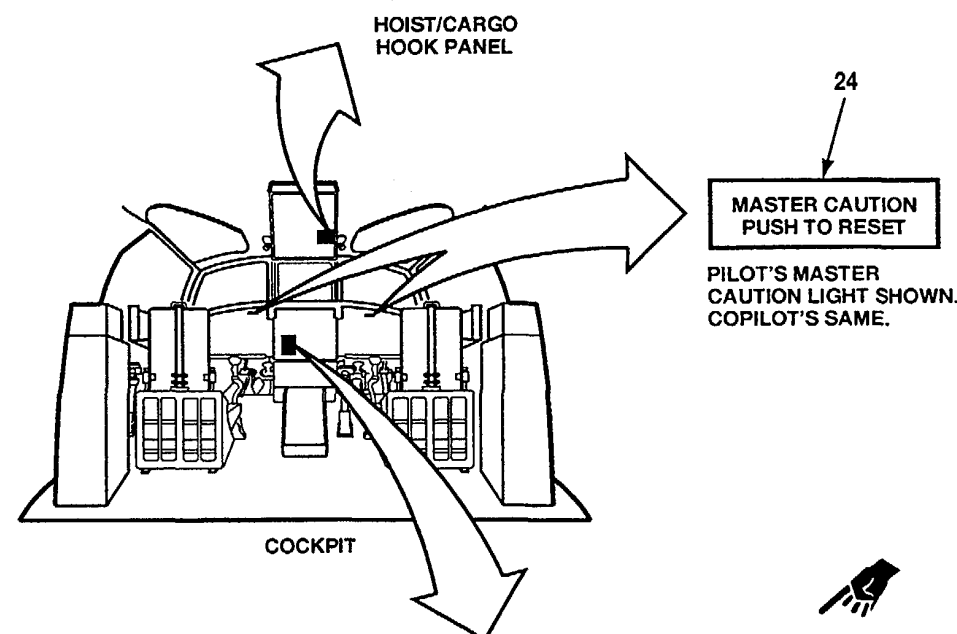
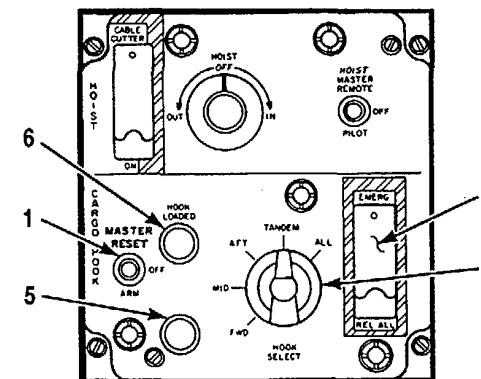

A65529

TASK

RESULT

CAUTION

When manual release has been pulled, do not press any CARGO HOOK RELEASE switch or EMERG switch. Damage to cargo hook can occur.

53. Without **35** connect dial indicating scale to center cargo hook manual release handle (26). Pull up dial indicating scale.

Center cargo hook shall open and drop load. Dial indicating scale shall indicate less than 20 pounds when center cargo hook opens. MID HOOK OPEN capsule (12) and both master caution lights (24) shall come on. If hook does not open or dial indicating scale reads more than 20 pounds before hook opens, go to task 16-1.29. If MID HOOK OPEN capsule (12) does not come on, go to task 16-1.24.

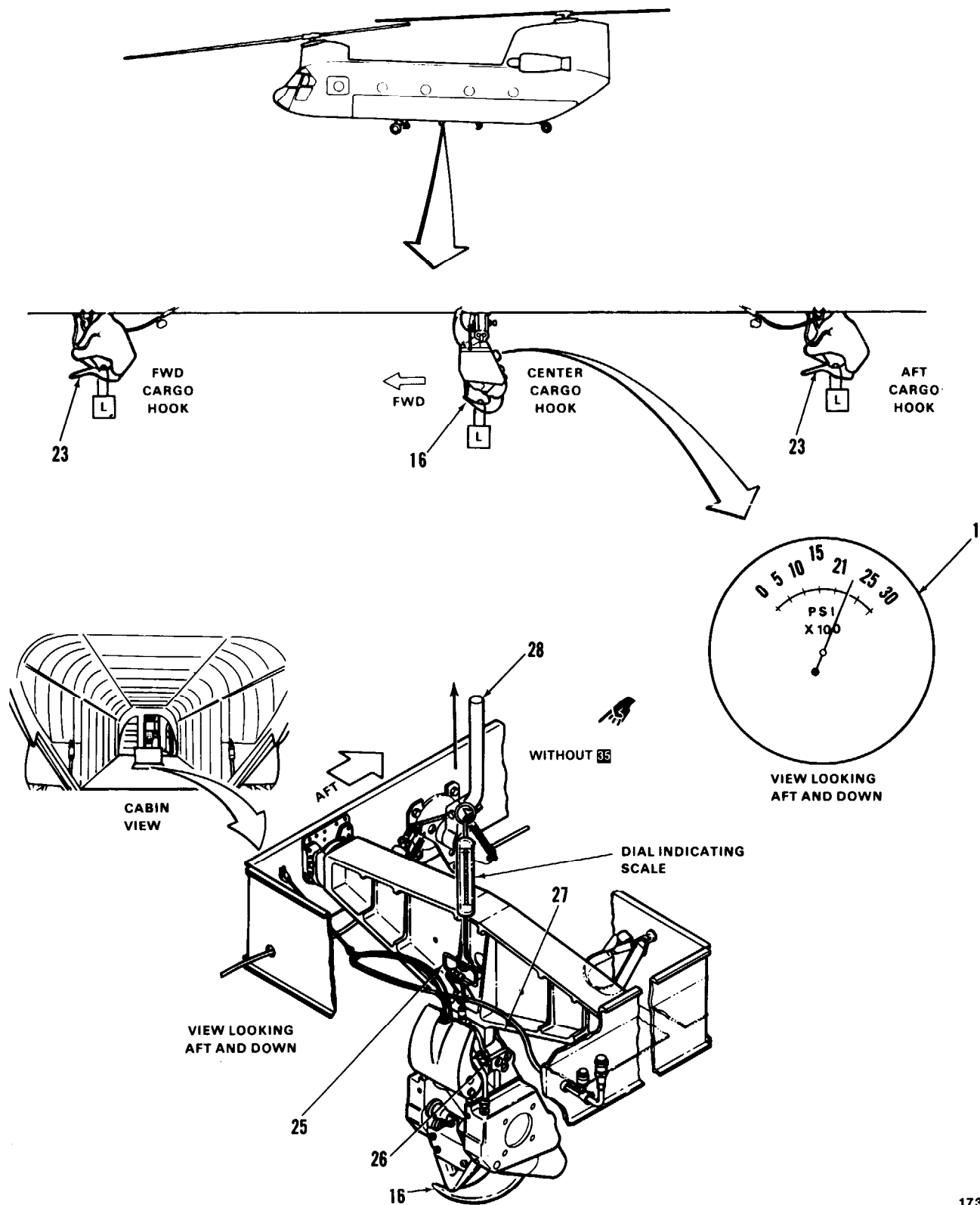

17325

TASK	RESULT
54. Remove dial indicating scale. Manually relatch center cargo hook (TM 55-1520-240-23).	MID HOOK OPEN capsule (12) and both master caution lights (24) shall go out.
55. Press down on hook (16) of center cargo hook. Use wood plank.	Center cargo hook shall not open. If it does, manually relatch center cargo hook (TM 55-1520-240-23), and repeat step 55. If hook opens again, replace center cargo hook.
56. Swing center cargo hook right until pivot block (26) contacts beam (27) and pull on hook (16).	Center cargo hook shall not open. If it does, check rigging of manual release mechanism (TM 55-1520-240-23). Repeat step 56.
57. Repeat step 56 to the left. Then go to step 58.	
58. Without 35 pull tandem hook release lever (28) aft then to vertical position.	Forward and aft cargo hooks shall open and latch closed. FWD HOOK OPEN and AFT HOOK OPEN capsules (11 and 13) and master caution lights (24) shall come on. If either or both hooks do not open, go to task 16-1.29.
59. Push lever (28) forward to stowed position.	

CAUTION

When manual release has been pulled, do not press any CARGO HOOK RELEASE switch or EMERG switch. Damage to cargo hook can occur.

- 59.1. With 35 suspend a weight of 20-25 pounds from the forward and aft cargo hooks (23). Suspend a weight of 45 to 50 pounds from the center cargo hook (16).
- 59.2. Pull the triple hook manual release lever aft then back to the vertical position.
- 59.3. Push lever (28.1) forward to stowed position.

The forward, center, and aft cargo hooks shall open and drop loads. The forward and aft hook shall latch closed. **FWD HOOK OPEN**, **MID HOOK OPEN**, and **AFT HOOK OPEN** capsules (11, 12, and 13) and **MASTER CAUTION** lights (24) shall come on. If a cargo hook (or hooks) fails to open, go to task 16-1.29.

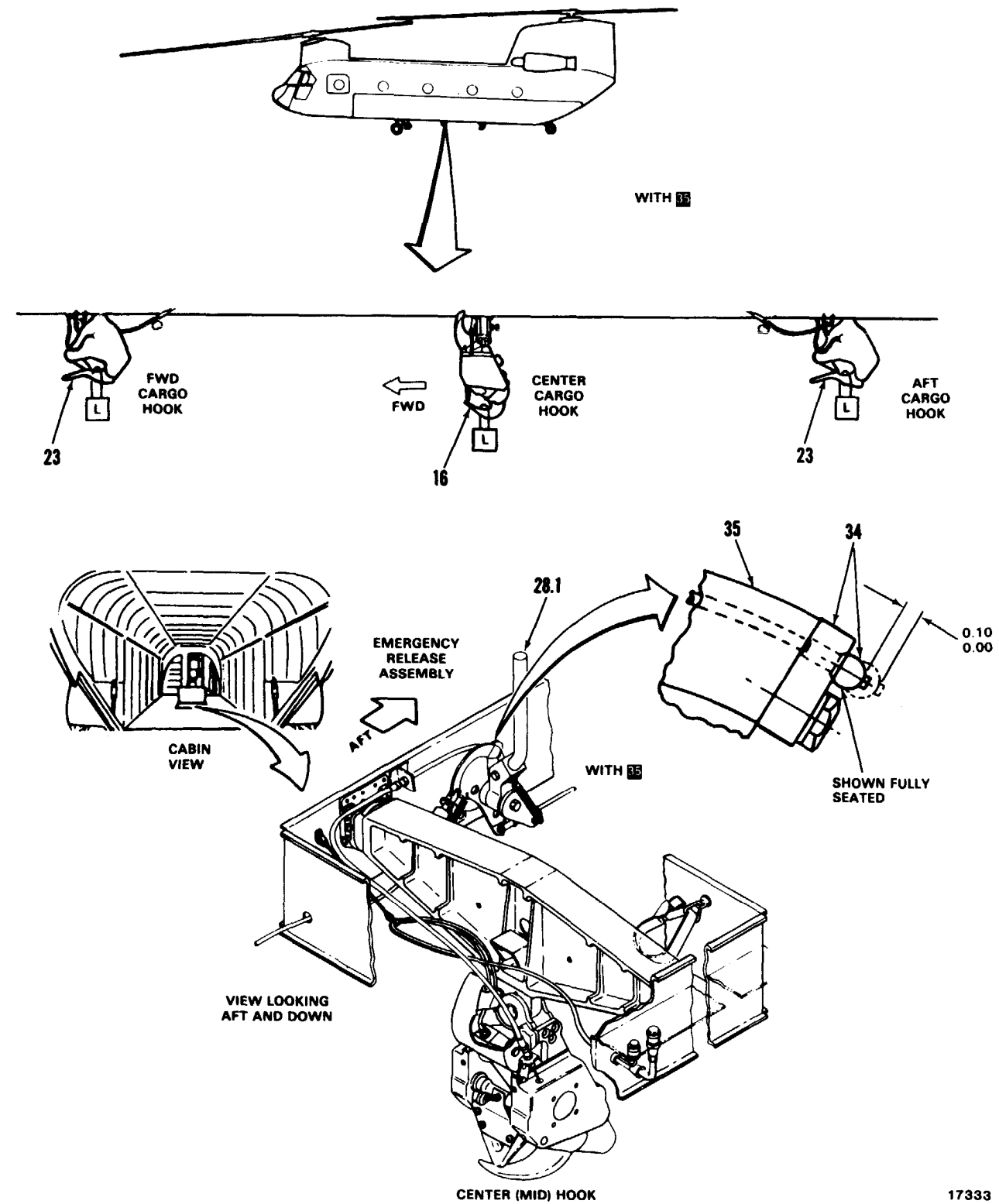

16-1.4 EXTERNAL CARGO HOOK SYSTEM OPERATIONAL CHECK
(Continued)

- 60. Pull down on forward and aft cargo hook load beams (23).
- 61. Set MASTER switch (1) to RESET, then to OFF.
- 62. Turn forward cargo hook manual release (29) counterclockwise. Pull down and hold open load beam (23).
- 63. Slowly move forward cargo hook load beam (23) up towards closed position.
- 64. Manually relatch forward cargo hook. Pull down on load beam (23).
- 65. Set MASTER switch (1) to RESET, then to OFF.
- 66. Turn aft cargo hook manual release (29) counterclockwise. Pull down and hold open load beam (23).
- 67. Slowly move aft cargo hook load beam (23) up towards closed position.

Both hooks shall remain closed. If a hook opens, pull load beam (23) to full open position and release it. Hook should then relatch.

Capsules (11 and 13) and master caution lights (24) shall go out. Forward and aft cargo hooks shall remain closed.

FWD HOOK OPEN capsule (11) and both master caution lights (24) shall come on.

FWD HOOK LOADED light (5) shall flash on just before hook is fully closed. If it does not, go to task 16-1.30.

Forward cargo hook shall not open. If it does, relatch it.

FWD HOOK OPEN capsule (11) and master caution lights (24) shall go out.

AFT HOOK OPEN capsule (13) and both master caution lights (24) shall come on.

AFT HOOK LOADED light (6) shall flash on just before hook is fully closed. If it does not, go to task 16-1.30.

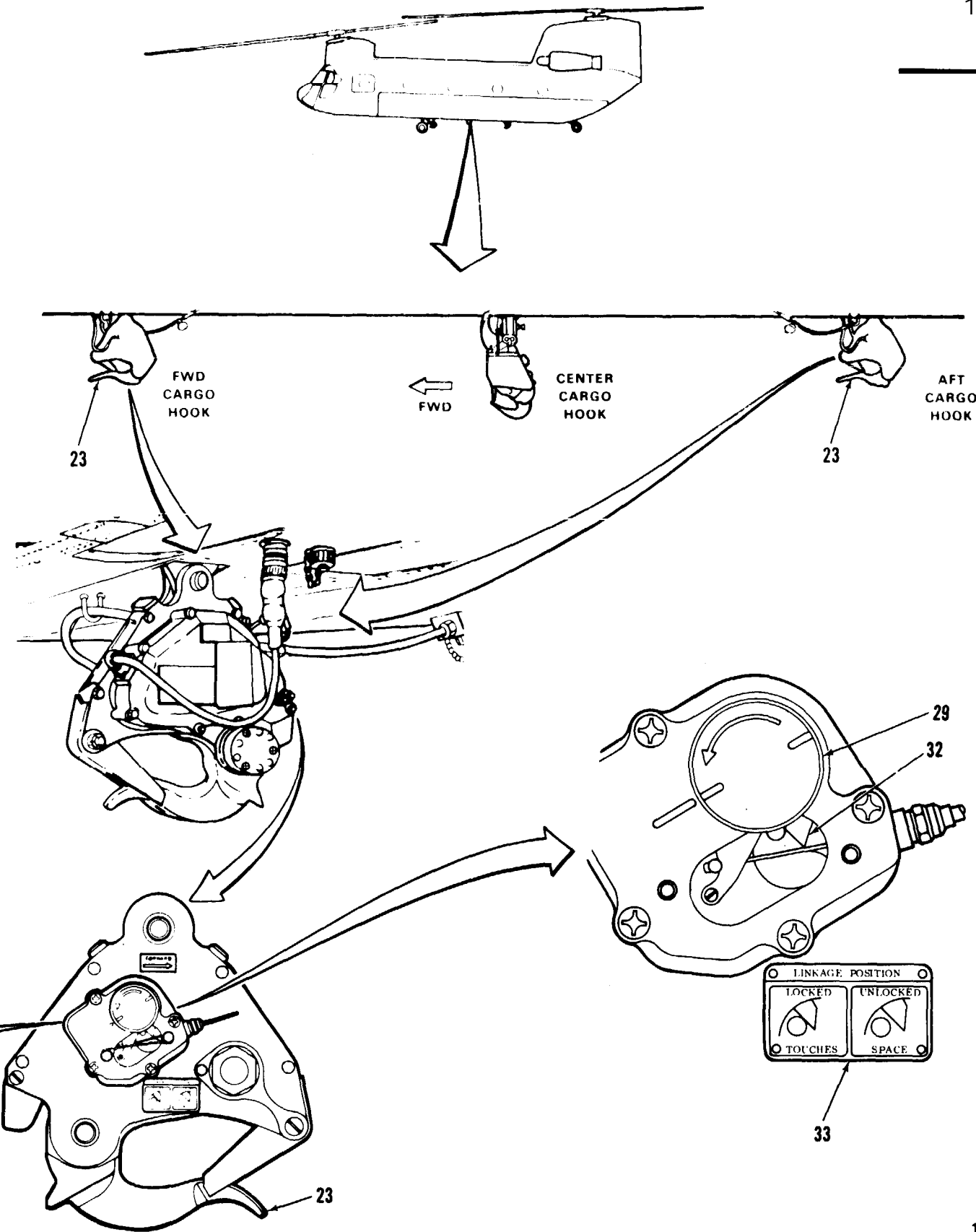

NOTE
FORWARD AND AFT
HOOK ADJUSTMENT WILL
BE THE SAME.

LEVER TO BE AGAINST
THE STOP

LINKAGE POSITION
LOCKED UNLOCKED
TOUCHES SPACE

16-1.4 EXTERNAL CARGO HOOK SYSTEM OPERATIONAL CHECK (Continued)

TASK	RESULT
68. Manually relatch aft cargo hook. Pull down on load beam (23).	Aft cargo hook shall not open.
69. Set MASTER switch (1) to RESET, then to OFF.	AFT HOOK OPEN capsule (13) and master caution lights (24) shall go out.
70. Suspend one 20-25 pound load from each load beam (23) on forward and aft cargo hooks.	
71. Turn manual release (29) counter-clockwise on forward and aft cargo hooks and release it.	Each cargo hook shall open when its release (29) is turned and relatch closed. If load is not released, replace cargo hook.
72. Manually move forward cargo hook full forward. Visually check clearance between cable ball end (30) and arm (31). Move cargo hook full aft. Visually check clearance between cable ball end and arm. Release cargo hook.	Clearance between cable ball end (30) and arm (31) shall be 0 to 3/16 inch. If it is not, adjust clearance. (TM 55-1520-240-23.)
WARNING Failure to perform following step can result in loss of external loads when lateral sway occurs resulting in personnel injury or death.	
73. Attach 15-foot rope to forward cargo hook load beam (23). Pull hook full left, then full right. Visually check clearance between cable ball and arm at both extremes. Use inspection mirror. Remove rope. clearance (TM 55-1520-240-23).	Forward cargo hook shall not open. If it does, check tandem hook release rigging. Adjust as required. (TM 55-1520-240-23). Clearance between cable ball end (30) and arm (31) shall be 0 to 3/16 inch. If it is not, adjust
74. Visually check position of linkage (32), and compare it with placard (33).	If linkage position is UNLOCKED, replace cargo hook.
75. Repeat steps 71 through 74 on aft cargo hook.	
76. With 35 visually check clearance between center cargo hook control cable ball end and quadrant.	Clearance between cable ball end (34) and quadrant (35) shall be 0 to 3/32 inch. If it is not, adjust clearance (TM 55-1520-240-23).

FOLLOW-ON MAINTENANCE:

- TM 55-1520-240-23:
- Battery disconnected.
- Electrical power off.
- Hydraulic power off.
- Center cargo hook serviced.
- Center cargo hook stowed.
- Center cargo hook access panel closed.

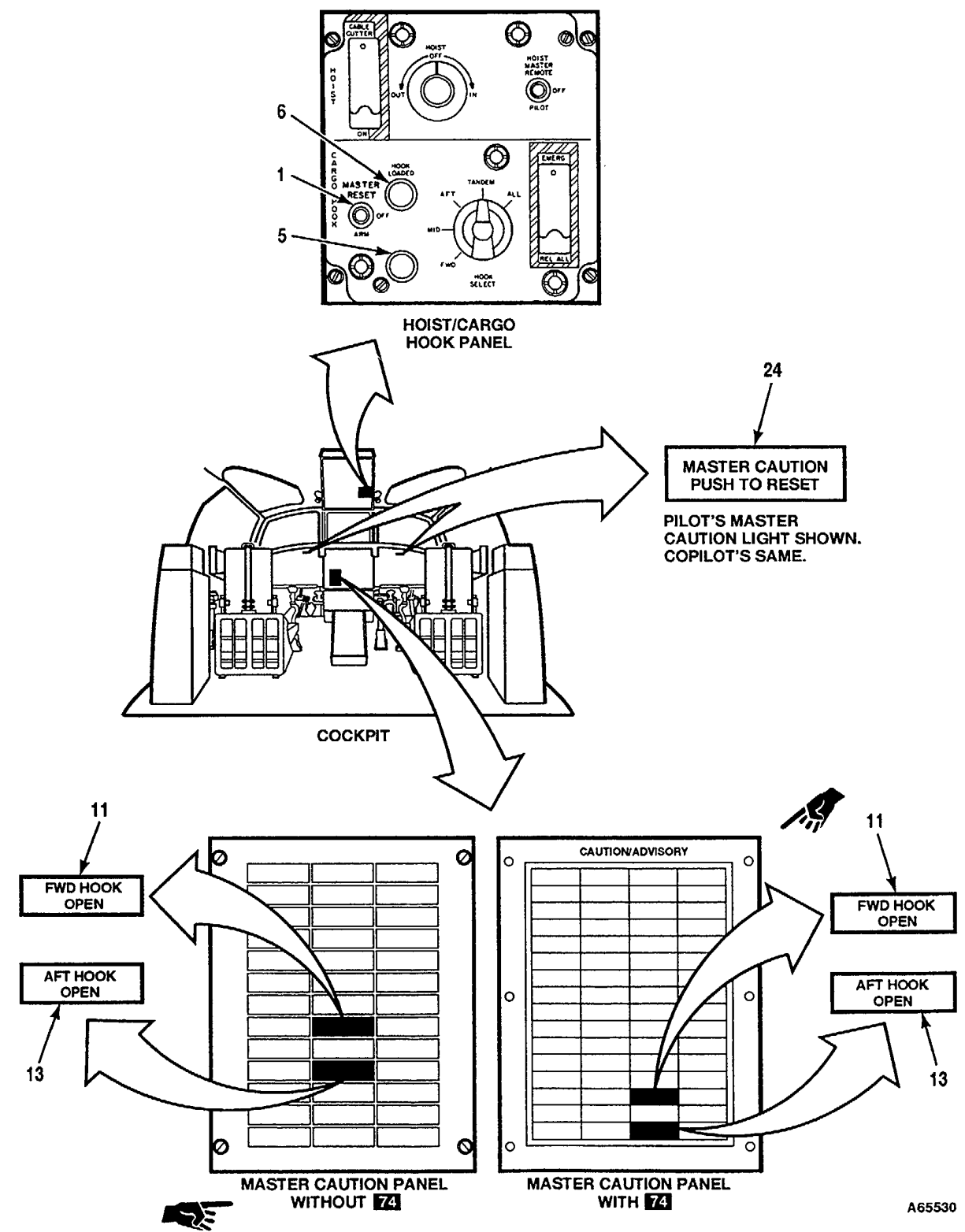

A65530

16-1.5 FWD OR AFT HOOK LOADED LIGHT IS LIT WHEN CARGO HOOK IS UNLOADED

FAULT ISOLATION PROCEDURE

INITIAL SETUP

Applicable Configurations:

All

Tools:

- Electrical Repairer's Tool Kit
NSN 5180-00-323-4915
- Multimeter

Materials

None

Personnel Required:

68F20 Aircraft Electrician

References

TM 55-1520-240-23

Equipment Condition:

- TM 55-1520-240-23:
- Battery Connected
- Electrical Power On
- Hydraulic Power Off

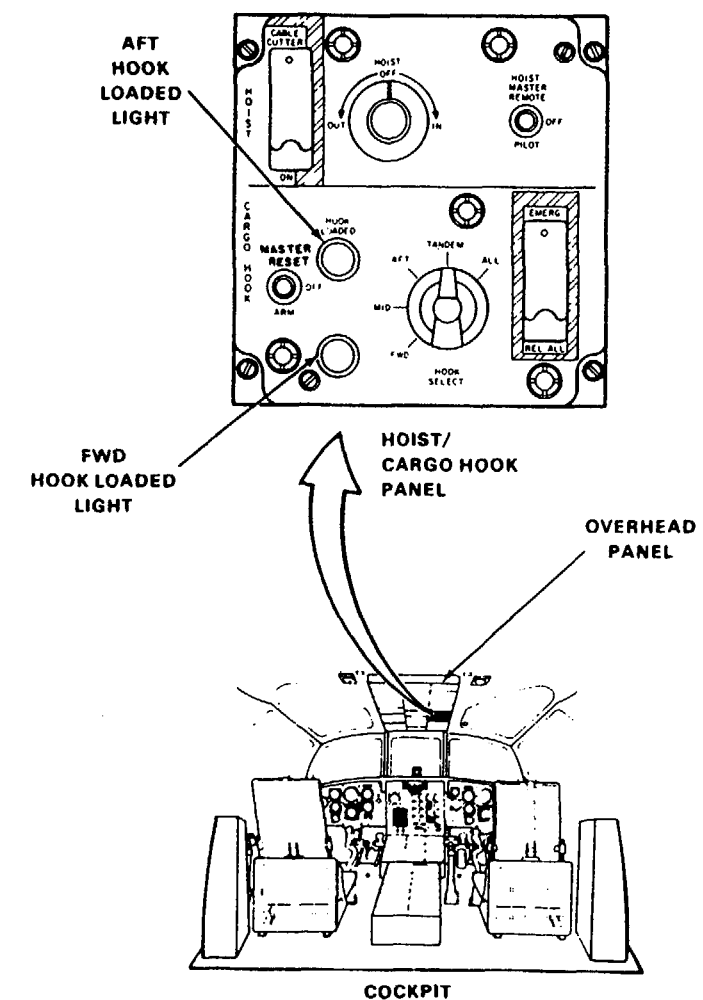
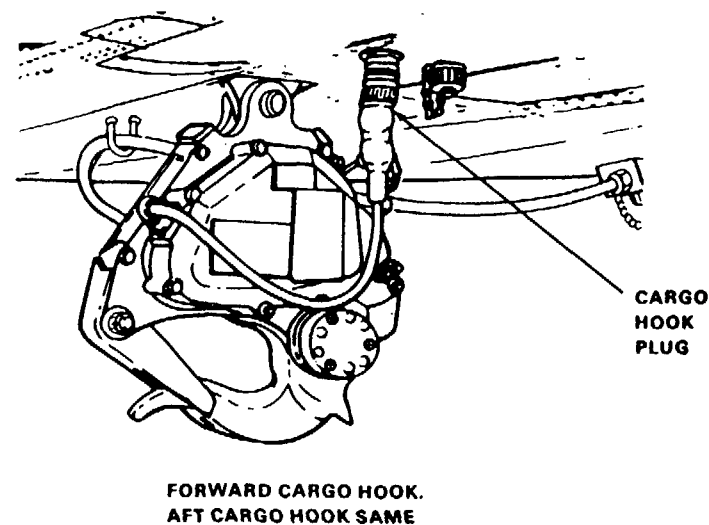
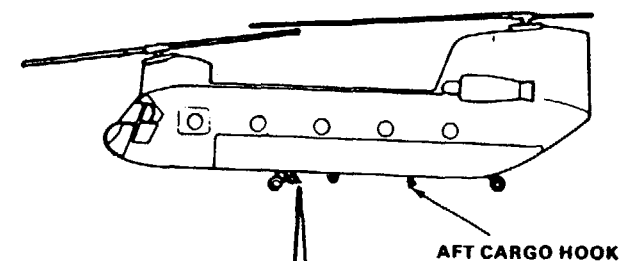

D145-6355-SPA

16-1.5 FWD OR AFT HOOK LOADED LIGHT IS LIT WHEN CARGO HOOK IS UNLOADED (Continued)

FWD HOOK LOADED LIGHT IS LIT WHEN CARGO HOOK IS UNLOADED

AFT HOOK LOADED LIGHT IS LIT WHEN CARGO HOOK IS UNLOADED

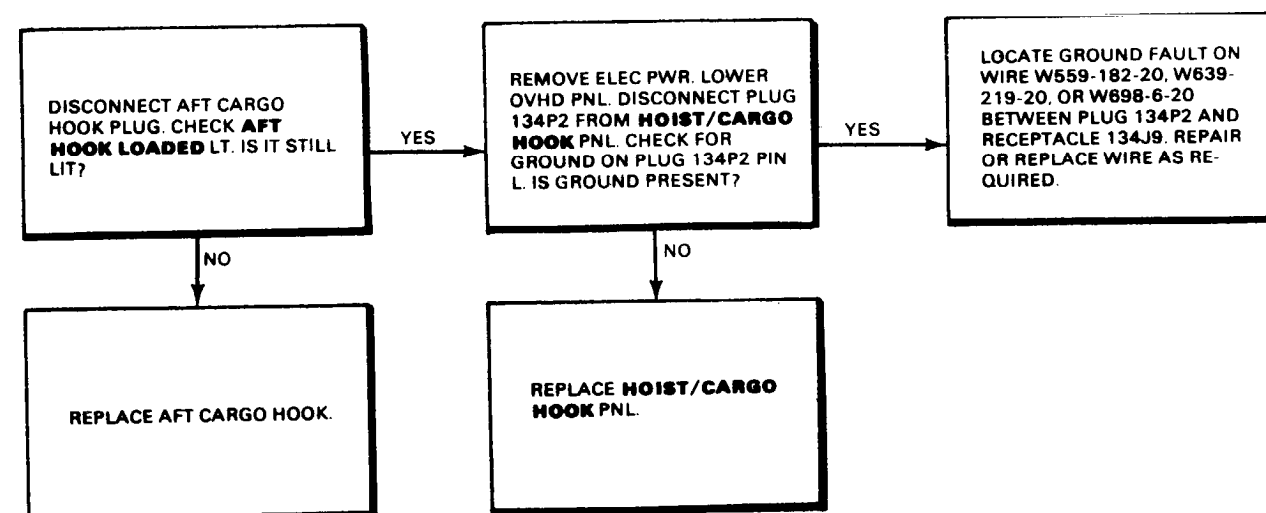
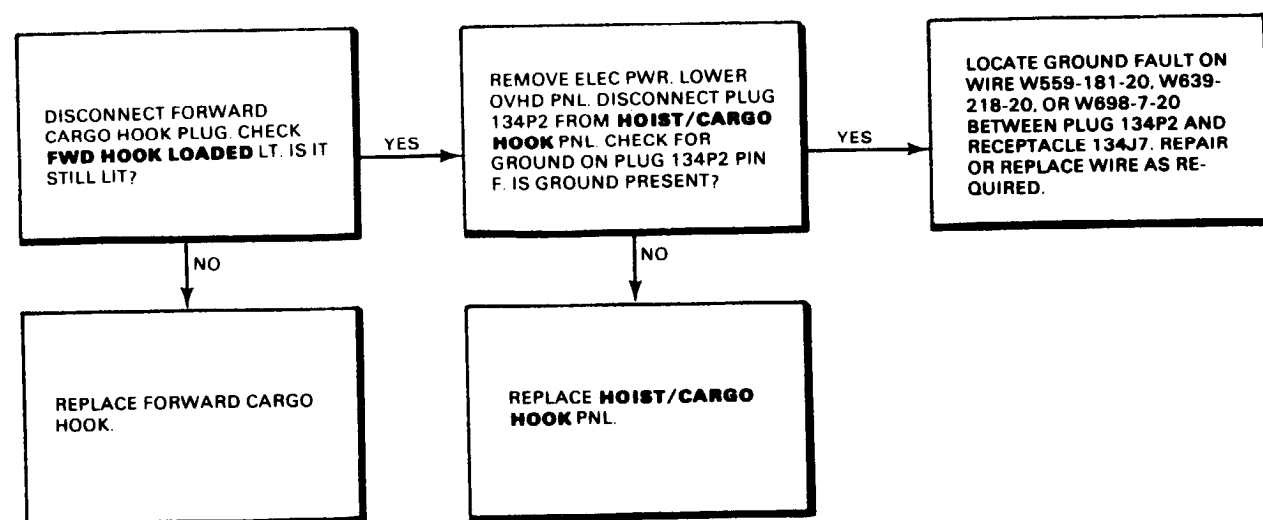

16-1.6 FWD OR AFT HOOK LOADED LIGHT DOES NOT
COME ON WHEN PRESSED

FAULT ISOLATION PROCEDURE

INITIAL SETUP

Applicable Configurations:
All

Tools:
Electrical Repairer's Tool Kit,
NSN 5180-00-323-4915
Multimeter

Materials:
None

Personnel Required:
68F20 Aircraft Electrician

References:
TM 55-1520-240-23

Equipment Condition:
TM 55-1520-240-23:
Battery Connected
Electrical Power On
Hydraulic Power Off

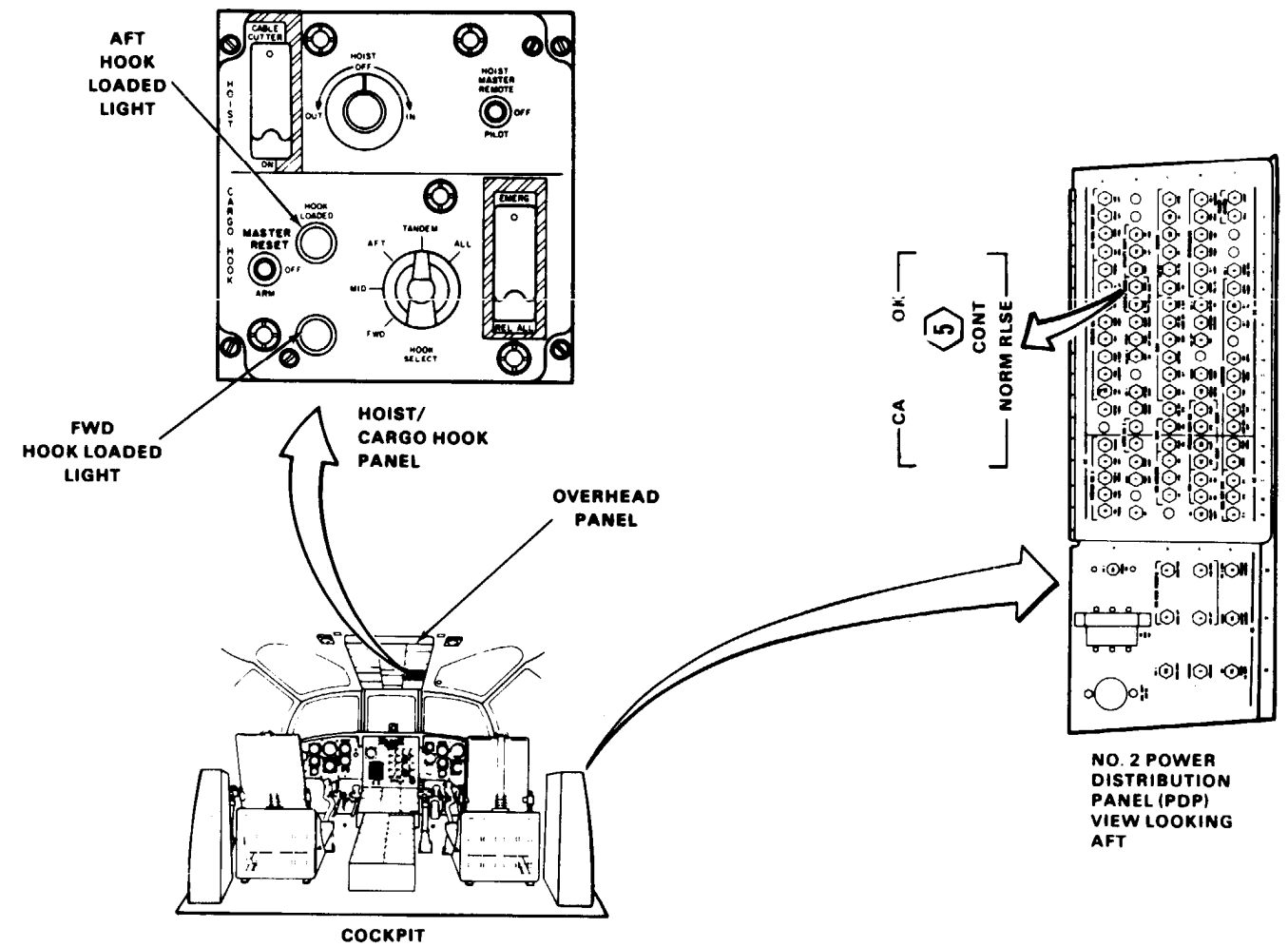

16-1.6 FWD OR AFT HOOK LOADED LIGHT DOES NOT COME ON WHEN PRESSED (Continued)

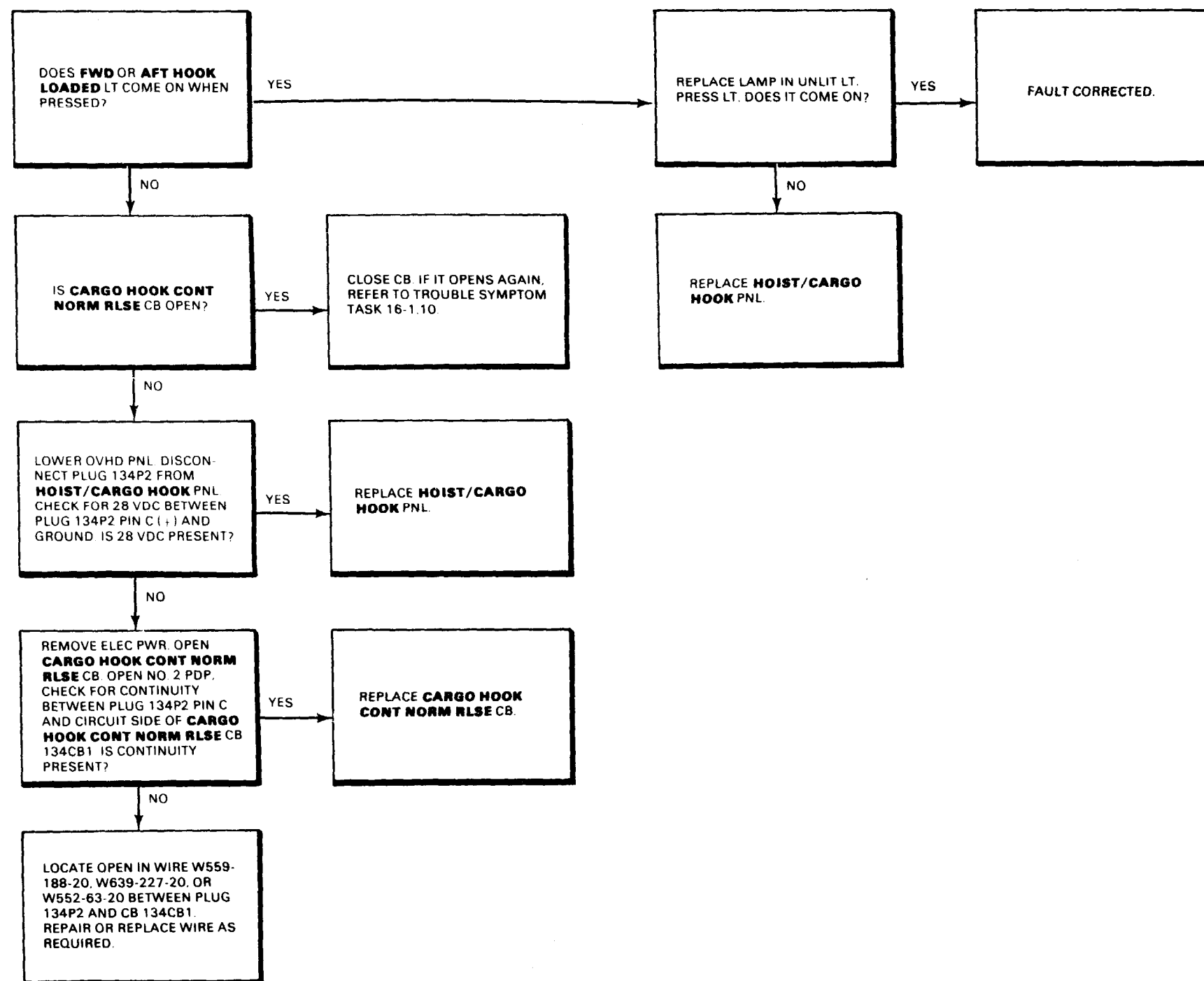

END OF TASK

16-1.7 CARGO HOOK PWR EMER REL CIRCUIT BREAKER DOES NOT STAY CLOSED

FAULT ISOLATION PROCEDURE

INITIAL SETUP

Applicable Configurations:
All

Tools:
Electrical Repairer's Tool Kit,
NSN 5180-00-323-4915
Multimeter

Materials:
None

Personnel Required:
68F20 Aircraft Electrician

References:
TM 55-1520-240-23

Equipment Condition:
TM 55-1520-240-23:
Battery Disconnected
Electrical Power Off
Hydraulic Power Off

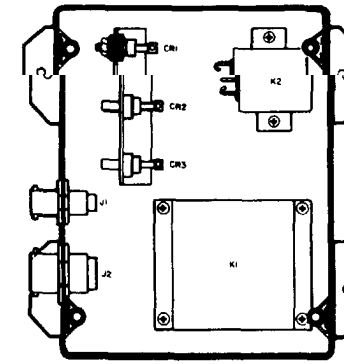

EMERGENCY HOOK
RELEASE RELAY
BOX STA 270

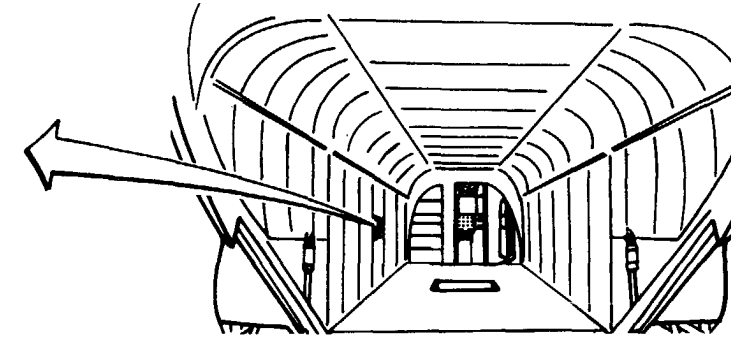

CABIN
VIEW

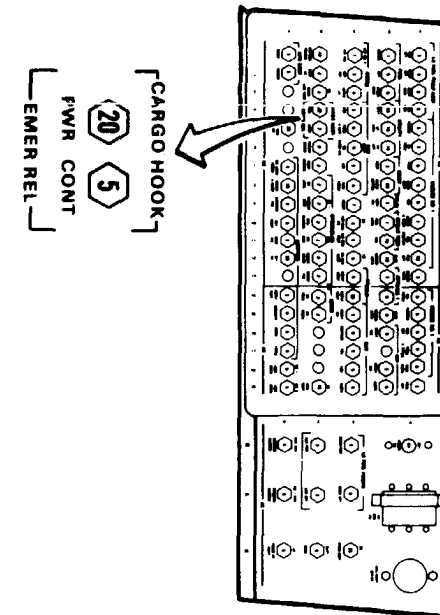
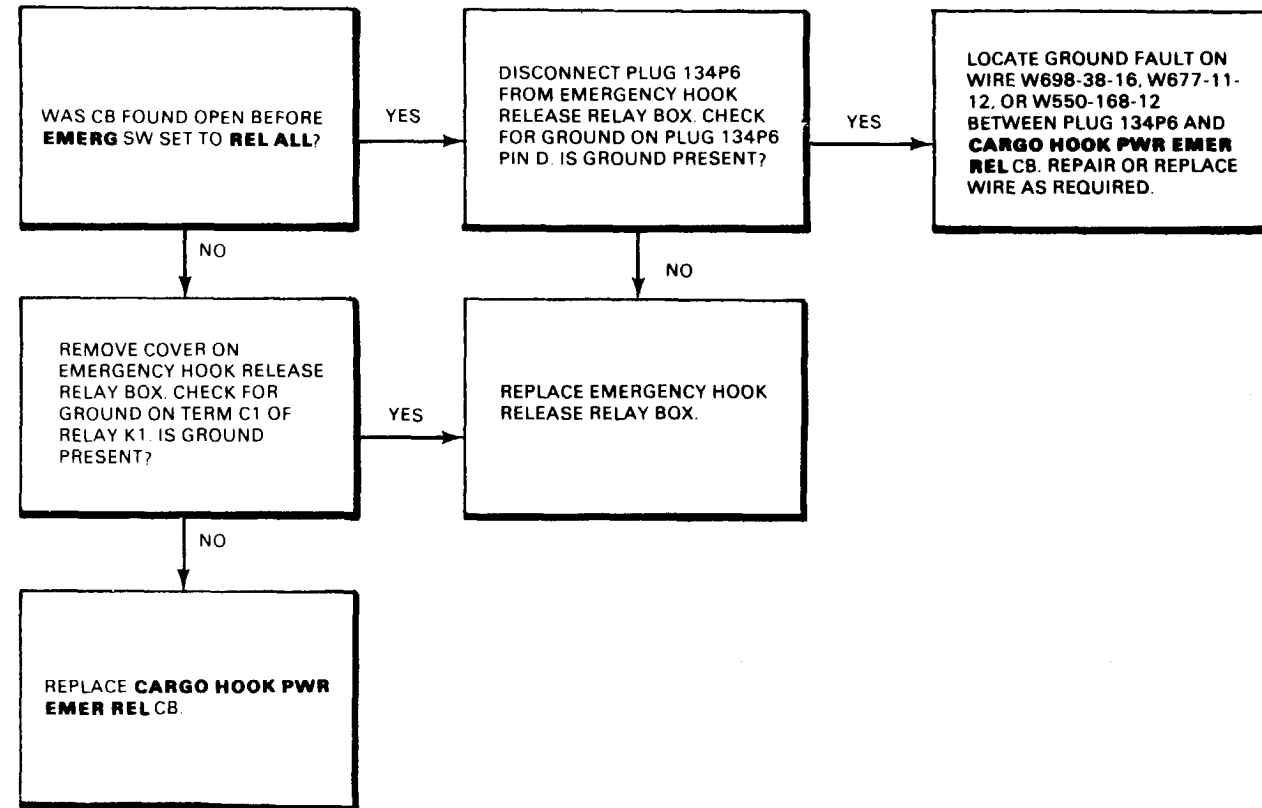

NO. 1 POWER
DISTRIBUTION
PANEL (PDP)
VIEW LOOKING
AFT

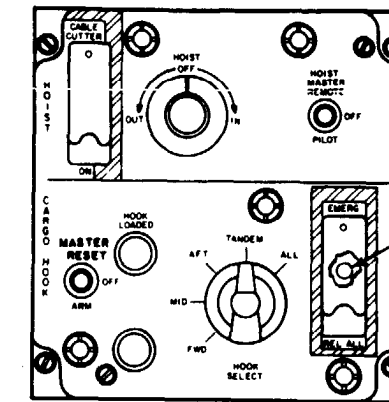

HOIST/
CARGO HOOK
PANEL

OVERHEAD
PANEL

EMERG
SWITCH

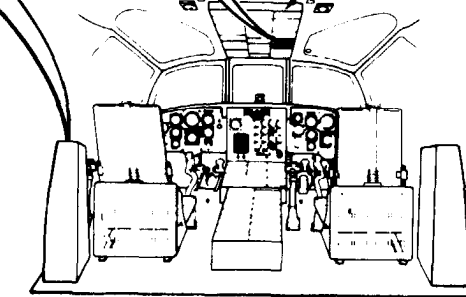

COCKPIT

16-1.8 CARGO HOOK CONT EMER RELCIRCUIT BREAKER
DOES NOT STAY CLOSED

16-1.8

FAULT ISOLATION PROCEDURE

INITIAL SETUP

Applicable Configurations:
All

Tools:
Electrical Repairer's Tool Kit,
NSN 5180-00-323-4915
Multimeter

Materials:
None

Personnel Required:
68F20 Aircraft Electrician

References:
TM 55-1520-240-23

Equipment Condition:
TM 55-1520-240-23:
Battery Disconnected
Electrical Power Off
Hydraulic Power Off

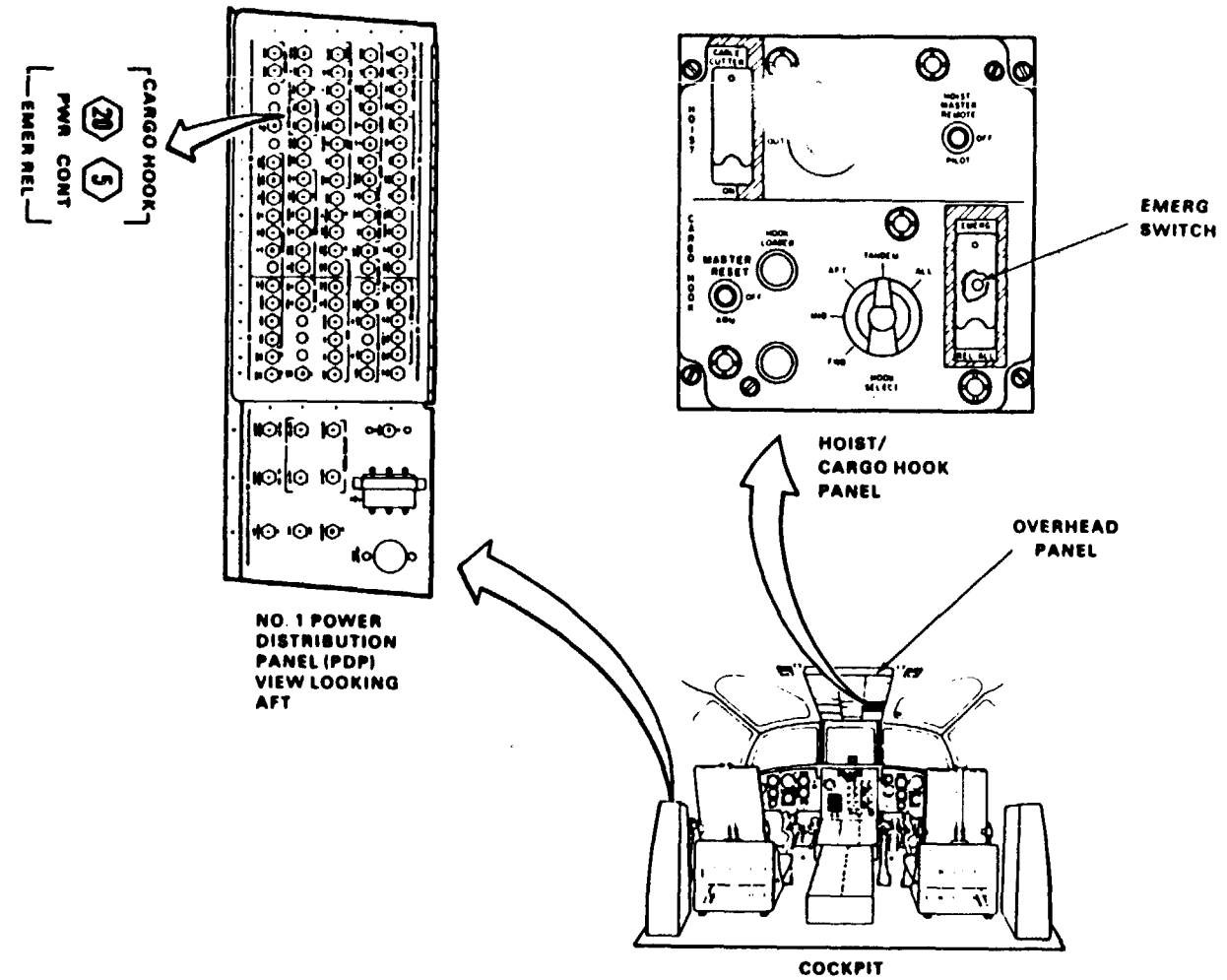
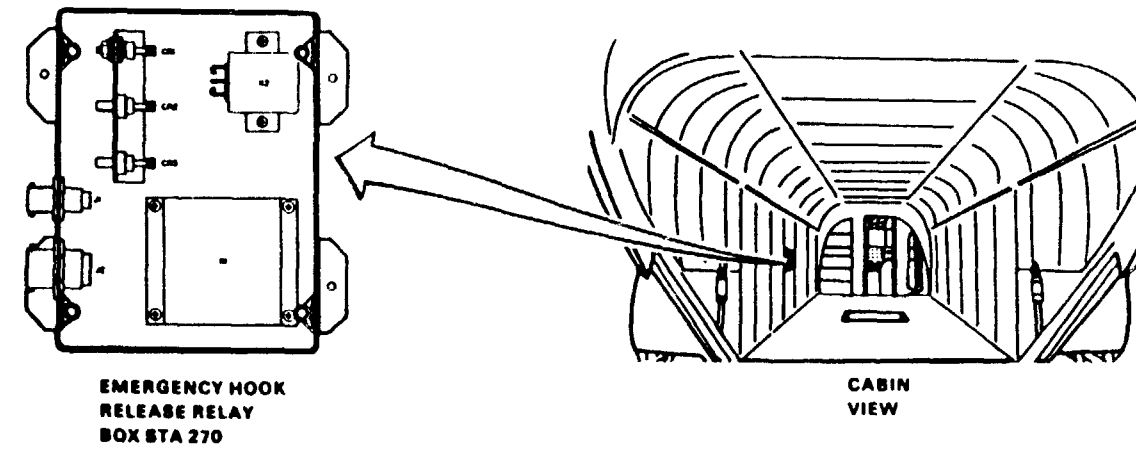

Page 16-25 is a blank page.

49-54

D145-6358-1
GO TO NEXT PAGE

16-1.8 CARGO HOOK CONT EMER RELCIRCUIT BREAKER
DOES NOT STAY CLOSED (Continued)

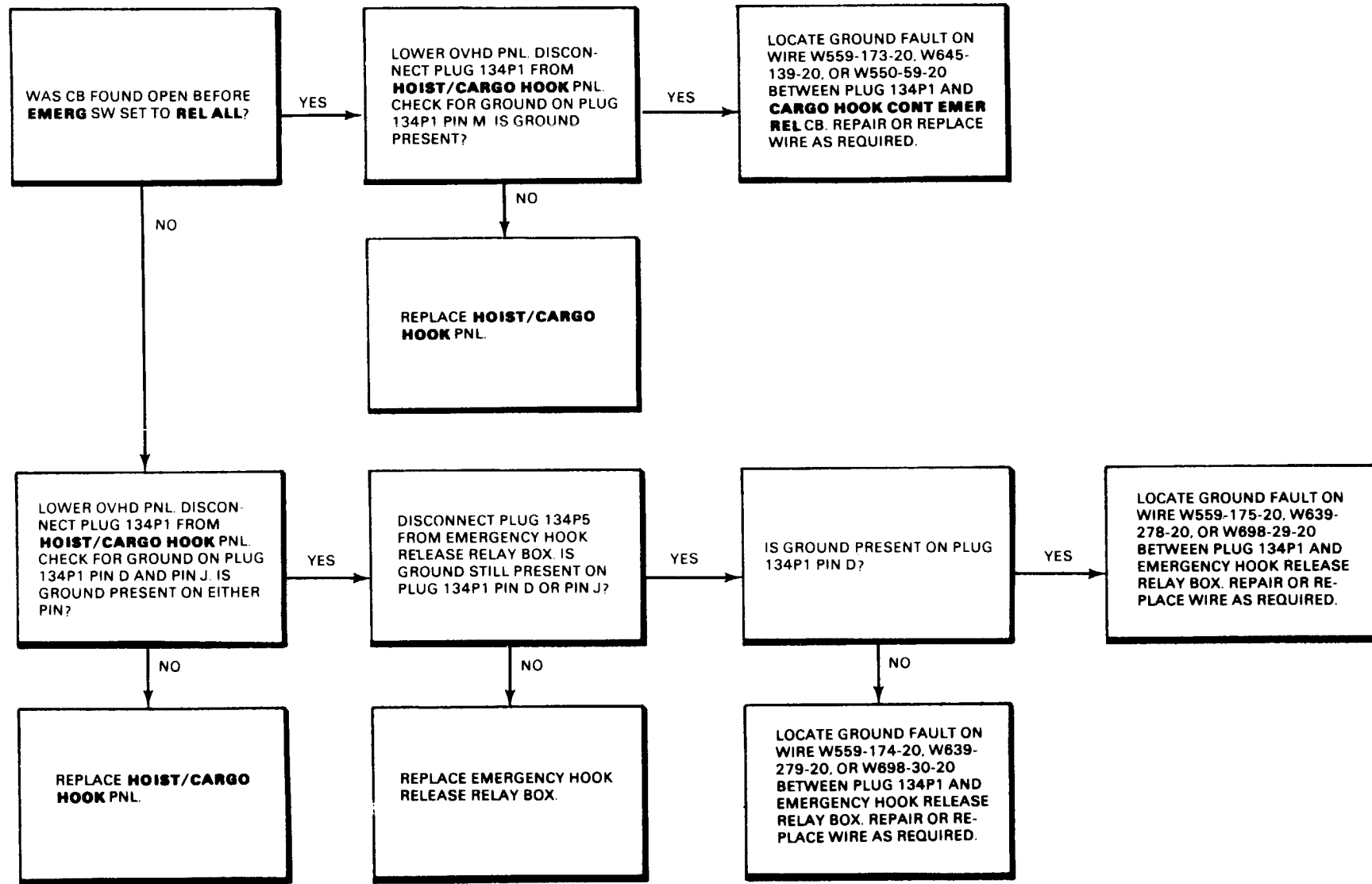

16-1.9 CARGO HOOK PWR NORM RLSE CIRCUIT BREAKER DOES NOT STAY CLOSED

FAULT ISOLATION PROCEDURE
INITIAL SETUP

Personnel Required:
68F20 Aircraft Electrician

Applicable Configurations:
All

References:
TM 55-1520-240-23

Tools:
Electrical Repairer's Tool Kit,
NSN 5180-00-323-4915
Multimeter

Equipment Condition:
TM 55-1520-240-23:
Battery Disconnected
Electrical Power Off
Hydraulic Power Off
Tunnel Access Doors Opened

Materials:
None

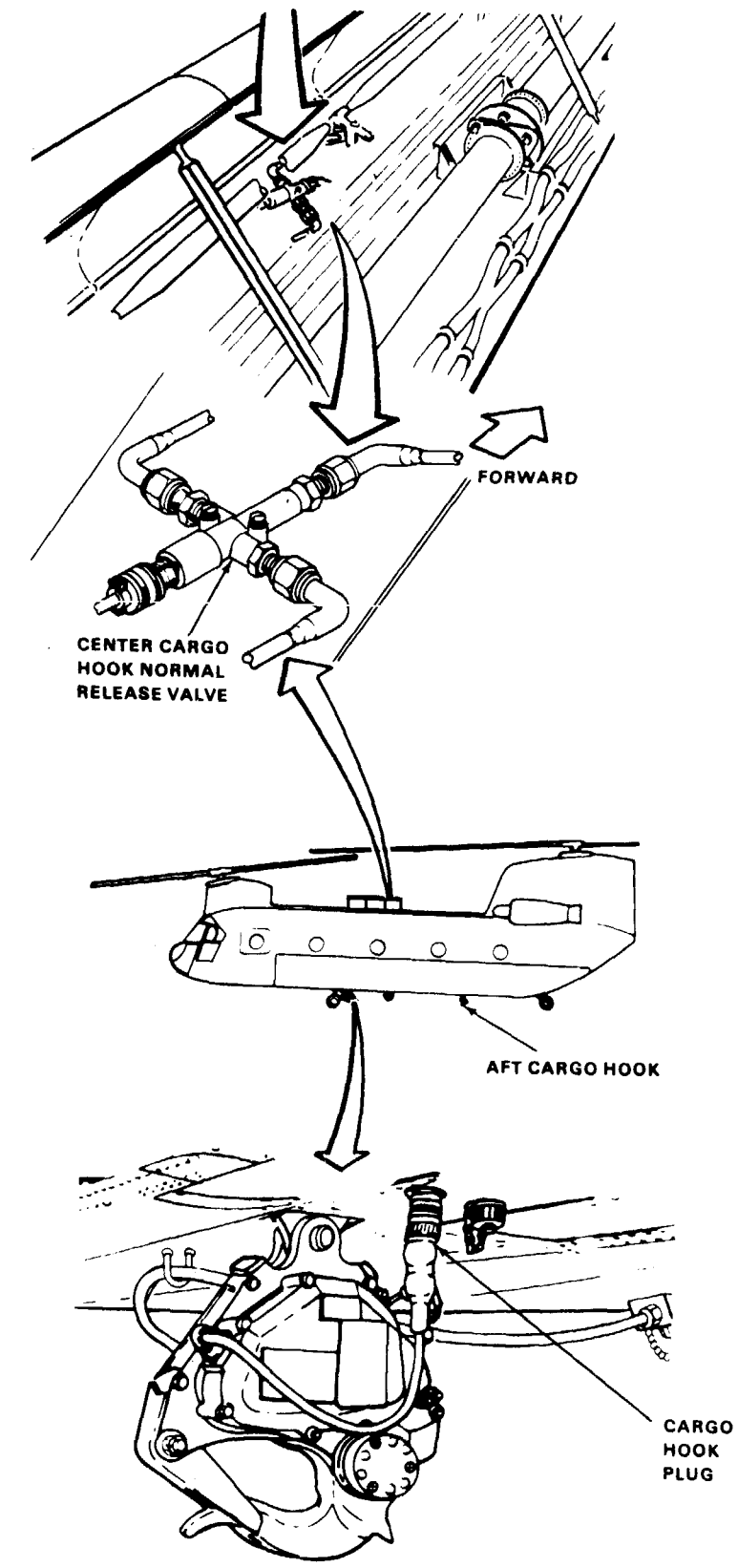
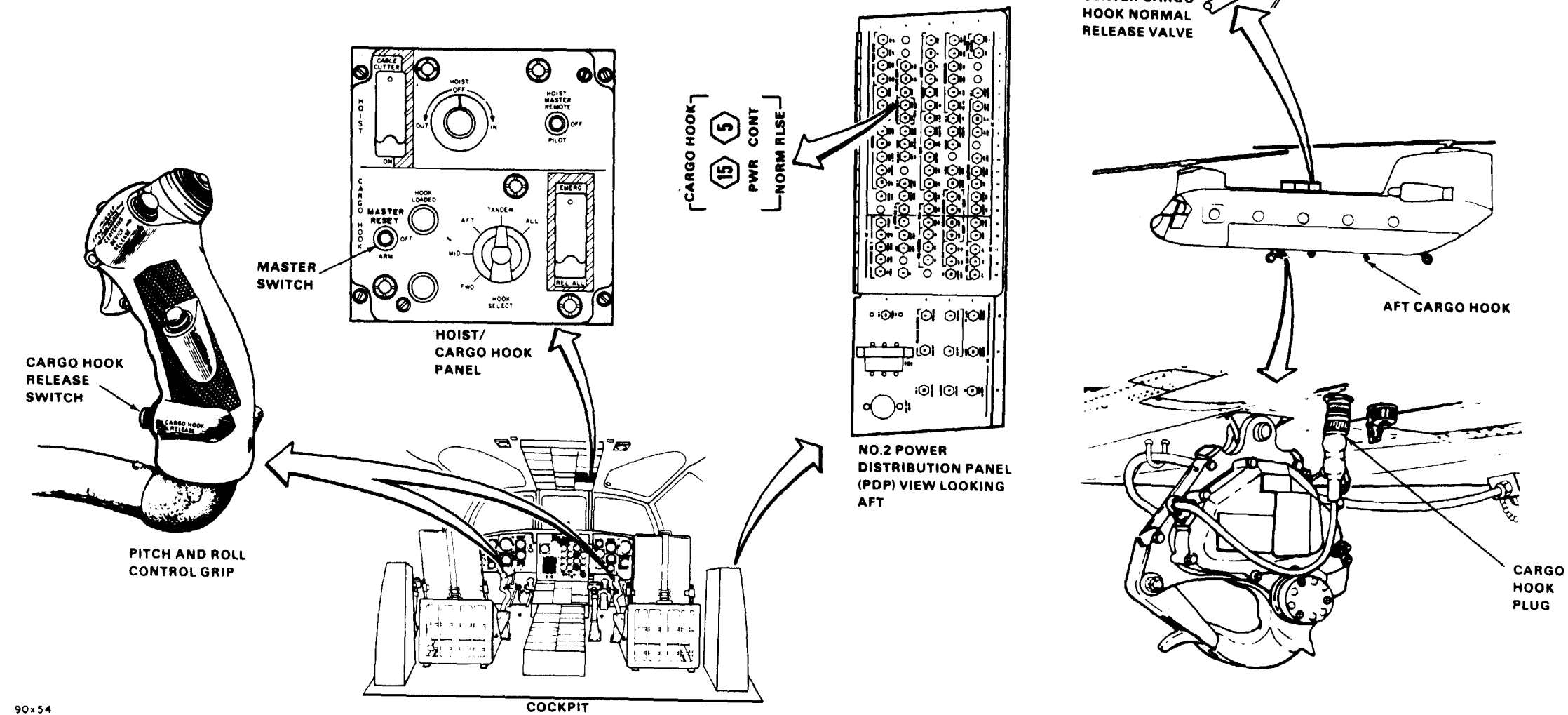

16-1.9 CARGO HOOK PWR NORM RLSE CIRCUIT BREAKER
DOES NOT STAY CLOSED (Continued)

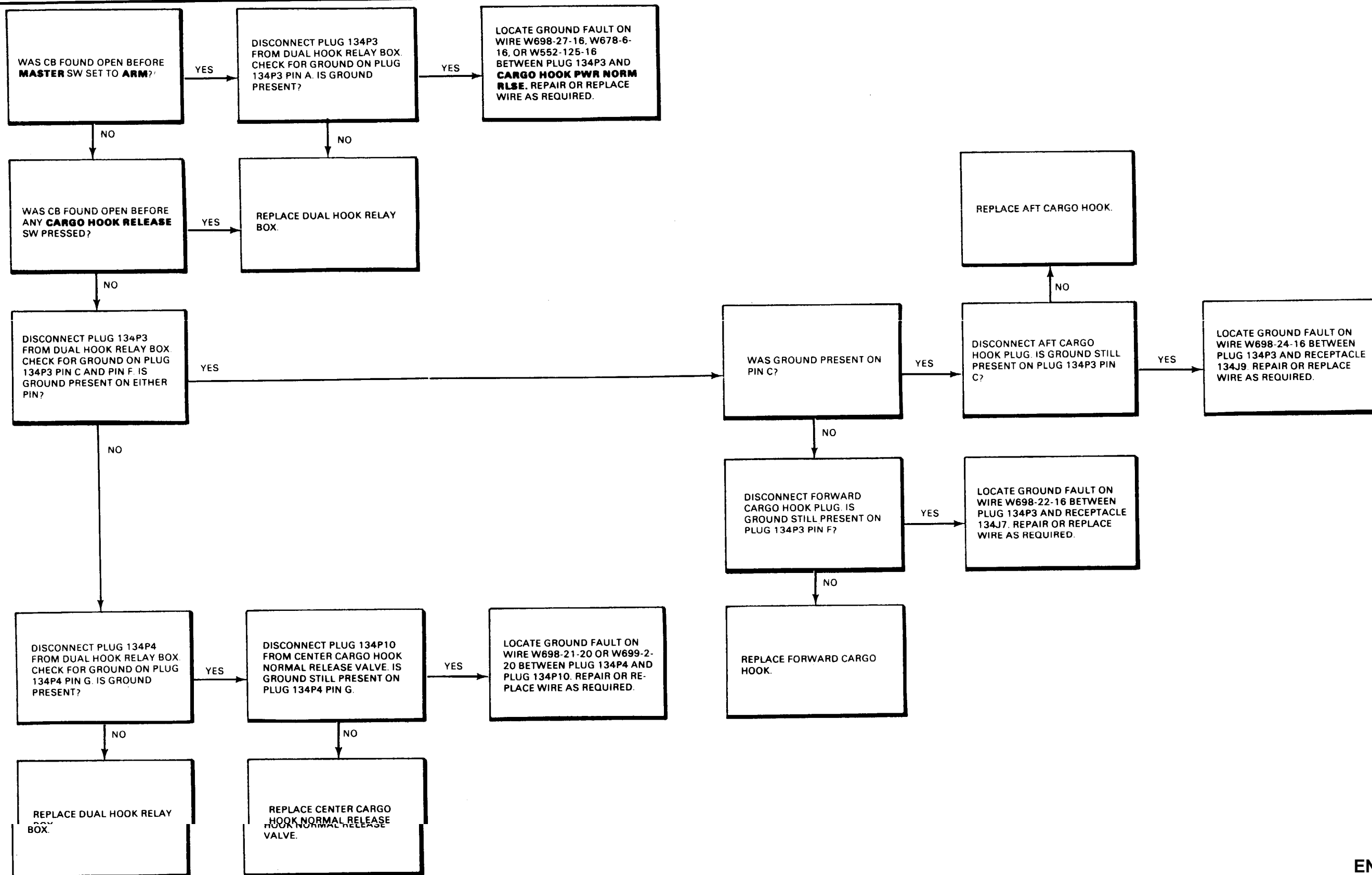

END OF TASK

16-1.10 CARGO HOOK CONT NORM RLSE CIRCUIT BREAKER
DOES NOT STAY CLOSED

FAULT ISOLATION PROCEDURE

Personnel Required:
68F20 Aircraft Electrician

INITIAL SETUP

Applicable Configurations:
All

References:
TM 55-1520-240-23

Tools:
Electrical Repairer's Tool Kit,
NSN 5180-00-323-4915
Multimeter

Equipment Condition:
TM 55-1520-240-23;
Battery Disconnected
Electrical Power Off
Hydraulic Power Off

Materials:
None

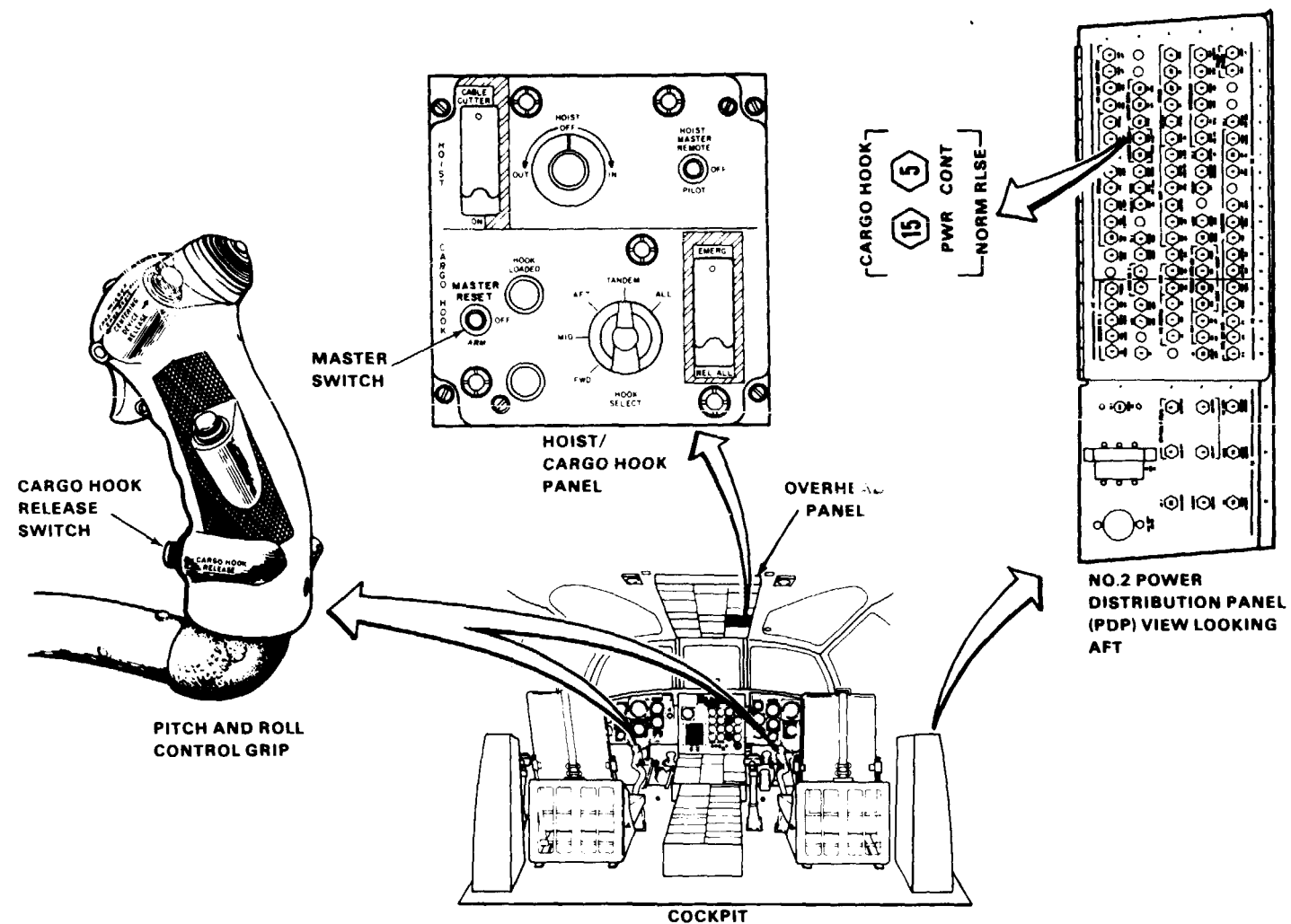
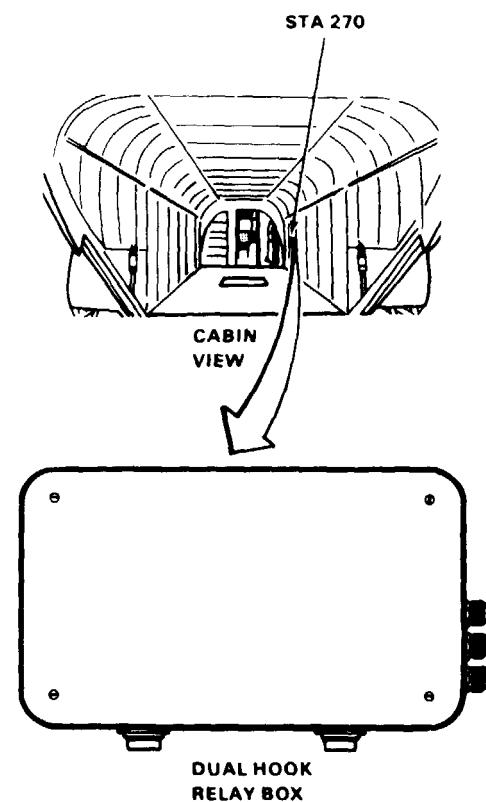

16-1.10 CARGO HOOK CONT NORM RLSE CIRCUIT BREAKER DOES NOT STAY CLOSED (Continued)

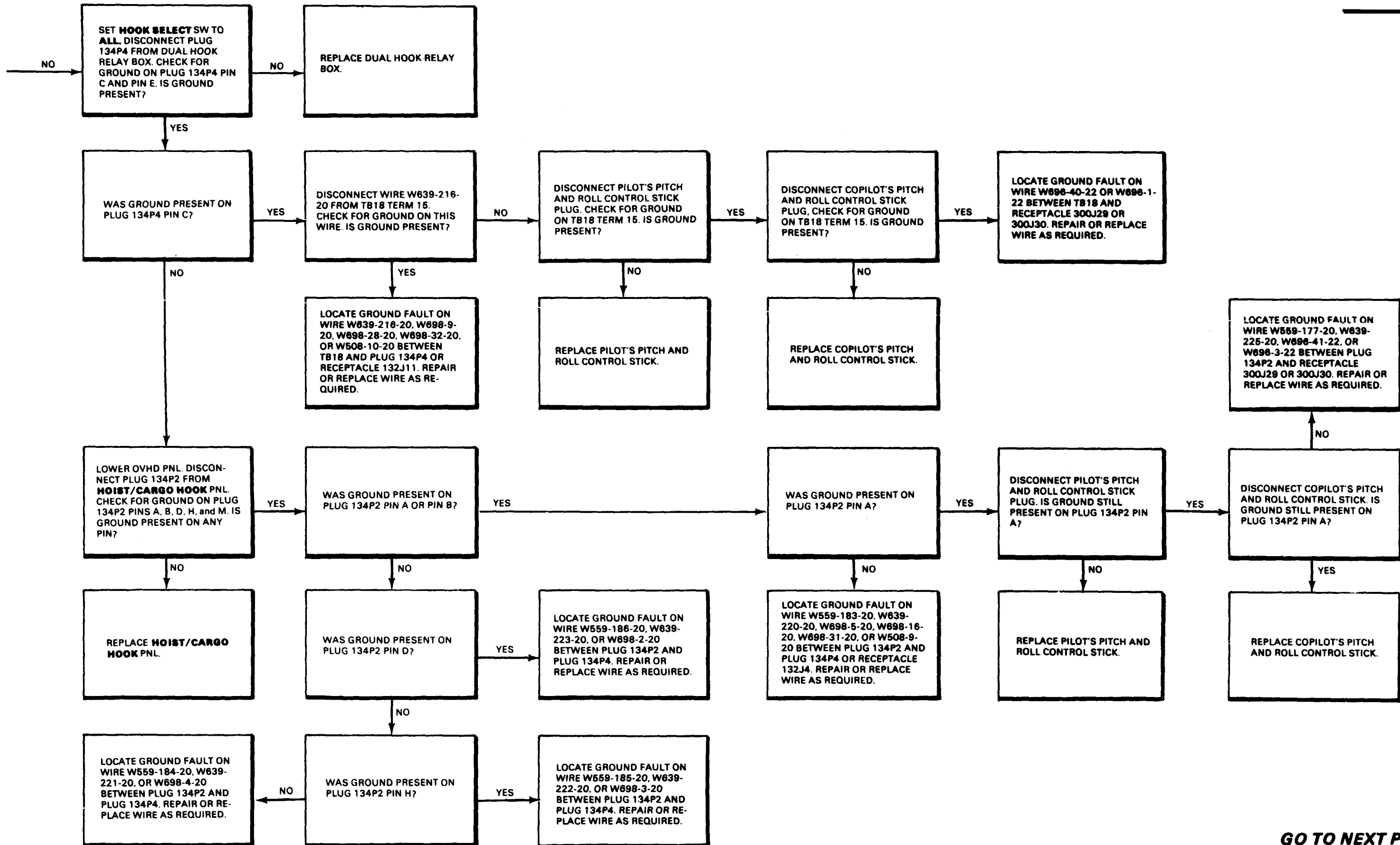

16-1.10 CARGO HOOK CONT NORM RLSE CIRCUIT BREAKER
DOES NOT STAY CLOSED (Continued)

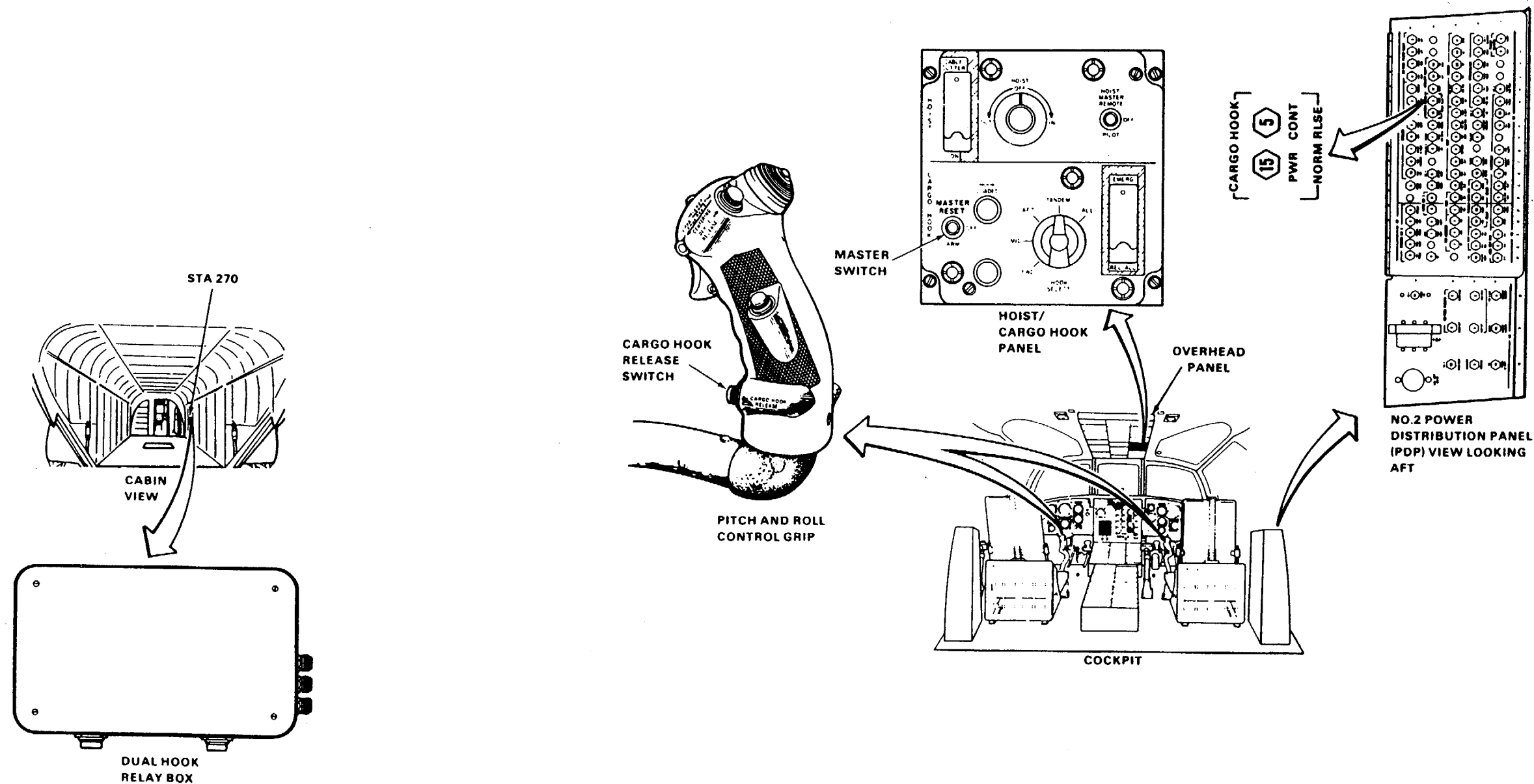

90X54

D145-10853-SPA

16-1.11 FWD HOOK OPEN CAPSULE LIT WHEN FORWARD CARGO HOOK CLOSED

FAULT ISOLATION PROCEDURE

INITIAL SETUP

Applicable Configurations

All

Tools

Electrical Repairer's Tool Kit,
NSN 5180-00-323-4915

Multimeter

Materials:

None

Personnel Required:

Aircraft Electrician

References:

TM 55-1520-240-23

Equipment Condition:

TM 55-1520-240-23:

Battery Connected

Electrical Power On

Hydraulic Power Off

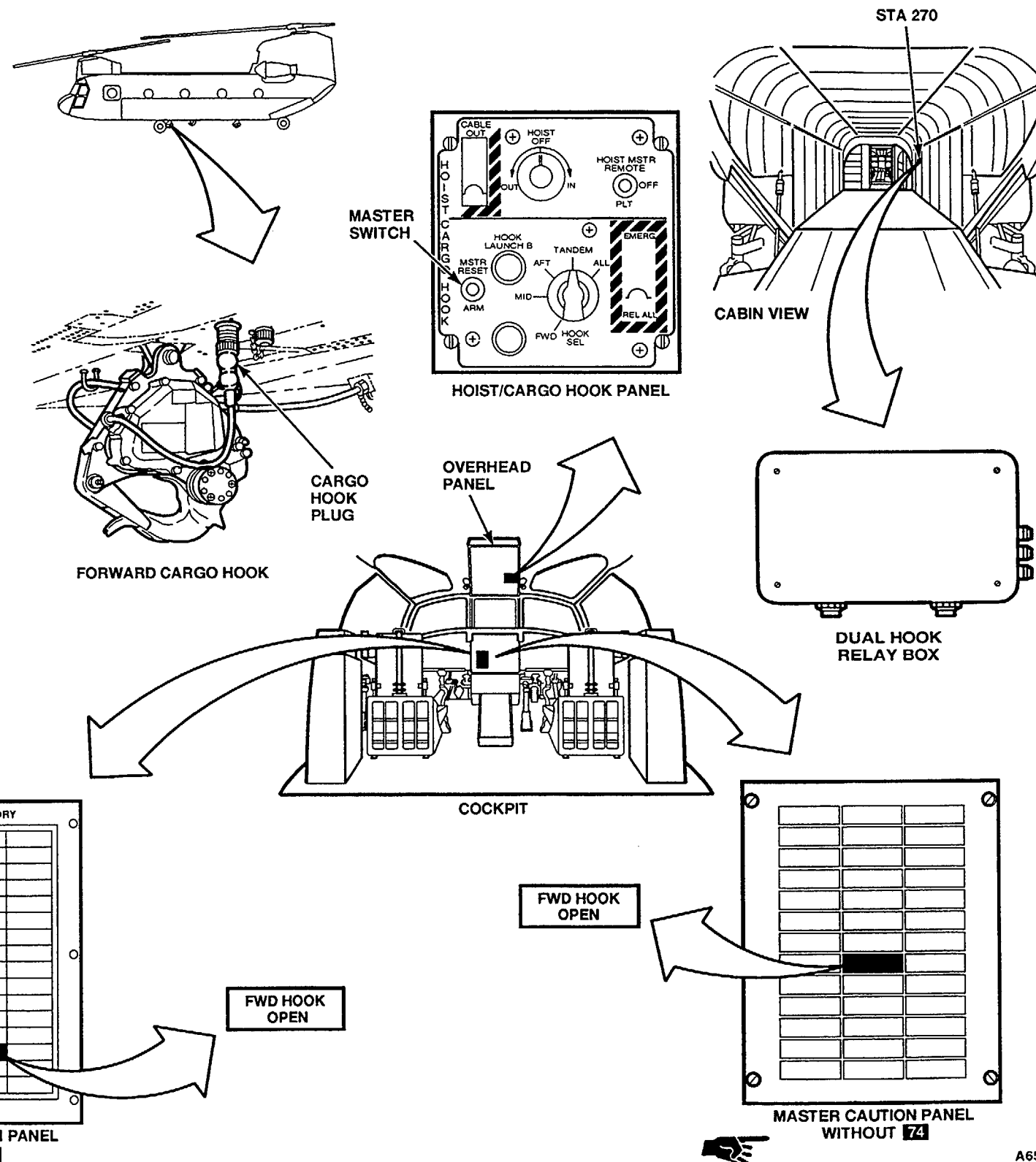
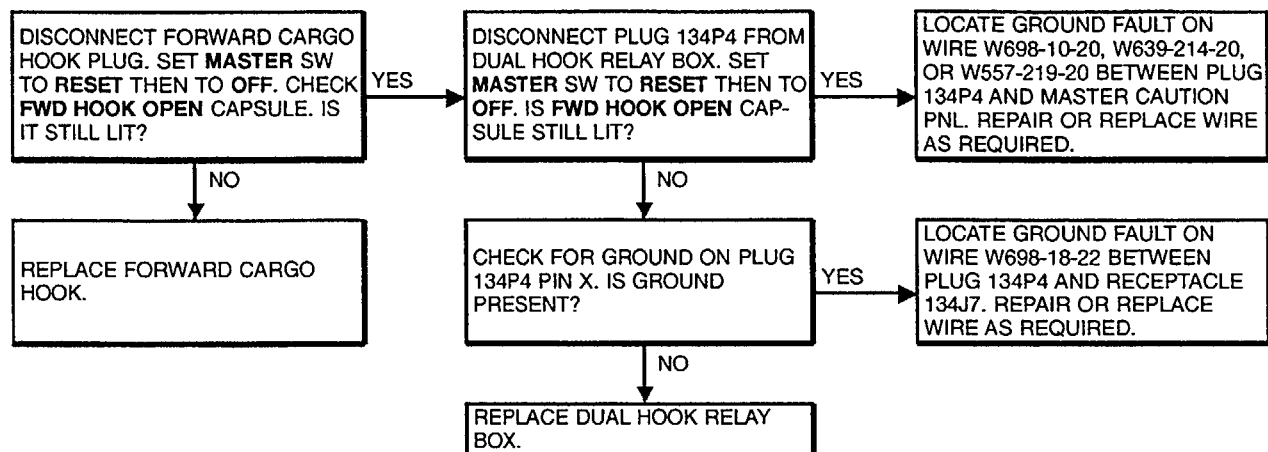

16-1.12 MID HOOK OPEN CAPSULE LIT WHEN CENTER CARGO HOOK CLOSED

FAULT ISOLATION PROCEDURE

INITIAL SETUP

Applicable Configurations

All

Tools

Electrical Repairer's Tool Kit,
NSN 5180-00-323-4915
Multimeter

Materials:

None

Personnel Required:

Aircraft Electrician

References

TM 55-1520-240-23

Equipment Condition:

TM 55-1520-240-23:

Battery Connected

Electrical Power On

Hydraulic Power Off

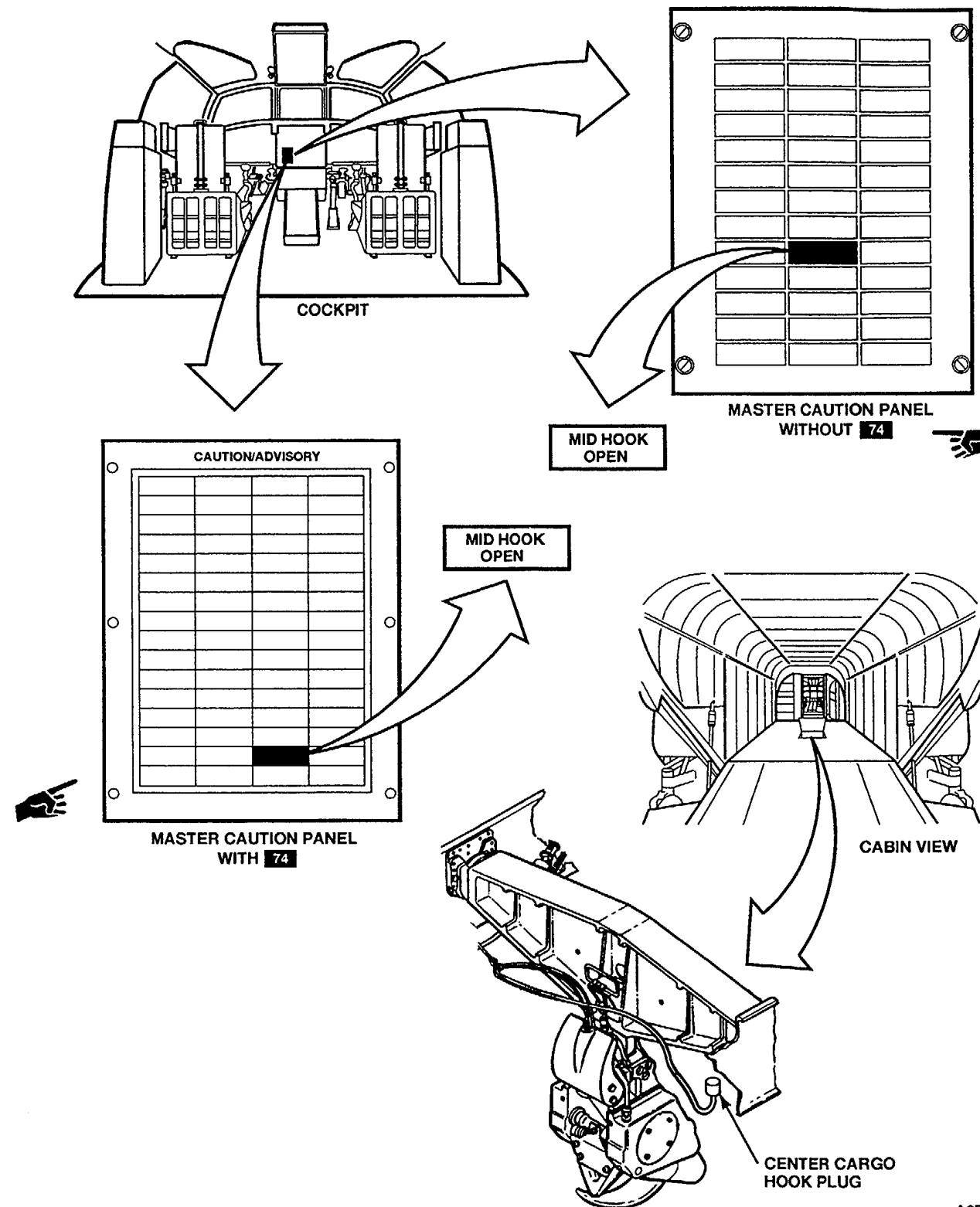
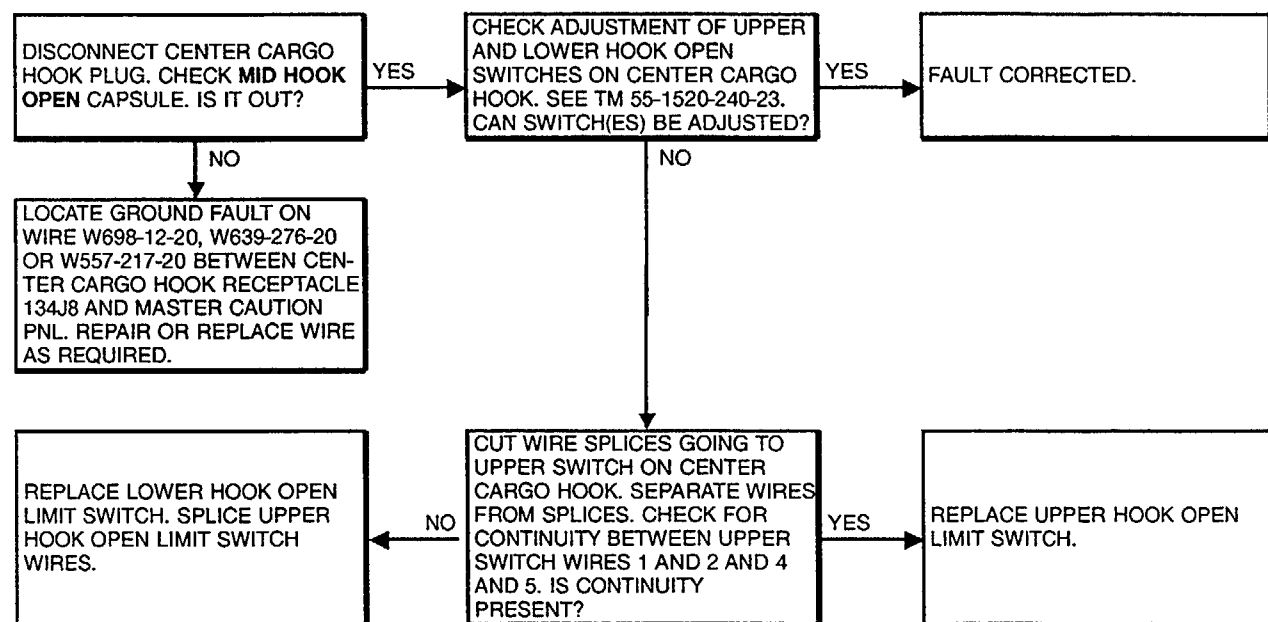

A65532

16-1.13 AFT HOOK OPEN CAPSULE LIT WHEN AFT CARGO HOOK CLOSED

FAULT ISOLATION PROCEDURE

INITIAL SETUP

Applicable Configurations:

All

Tools:

- Electrical Repairer's Tool Kit,
NSN 5180-00-323-4915
- Multimeter

Materials:

None

Personnel Required:

Aircraft Electrician

References

TM 55-1520-240-23

Equipment Condition:

TM 55-1520-240-23:

Battery Connected

Electrical Power On

Hydraulic Power Off

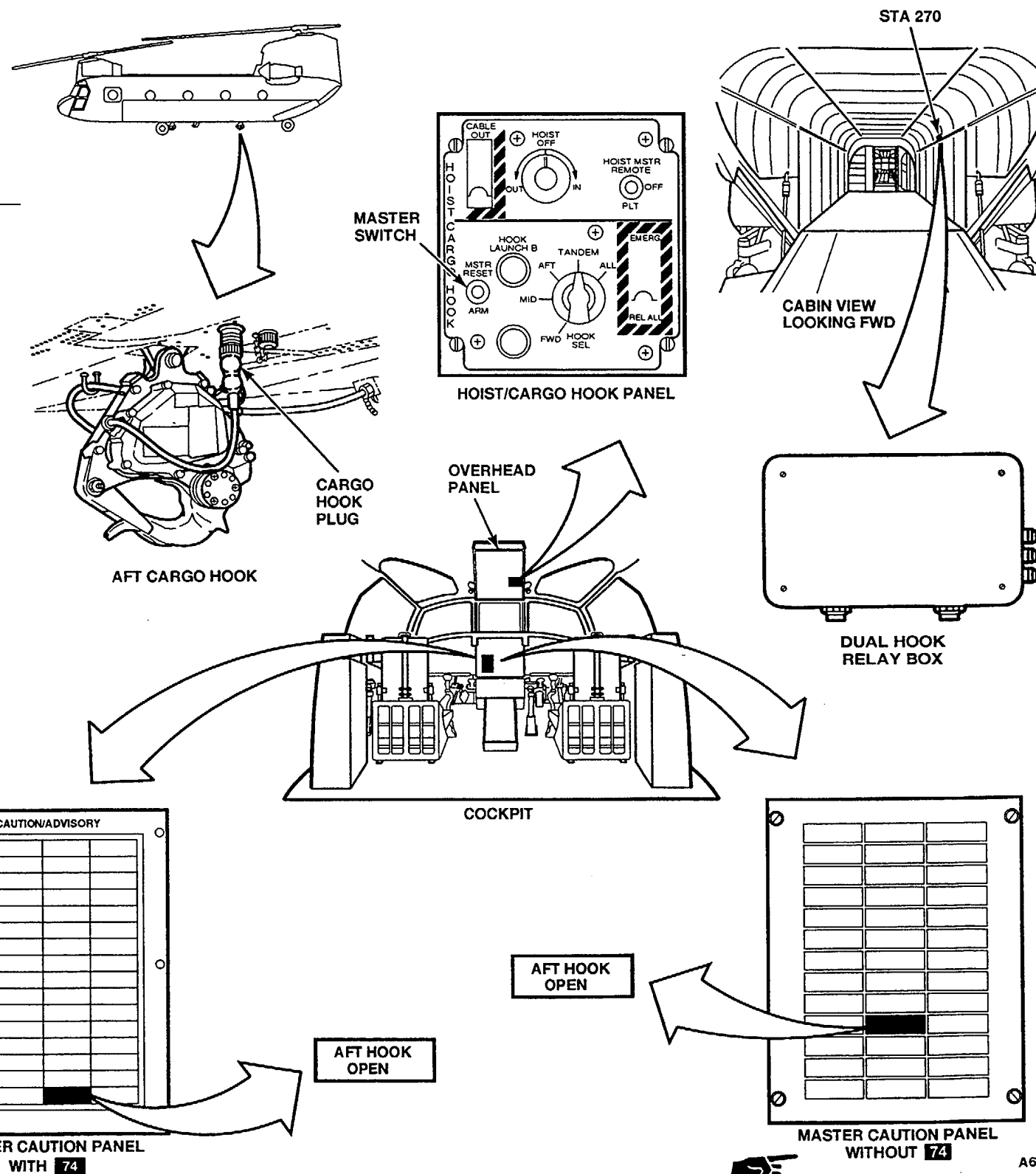
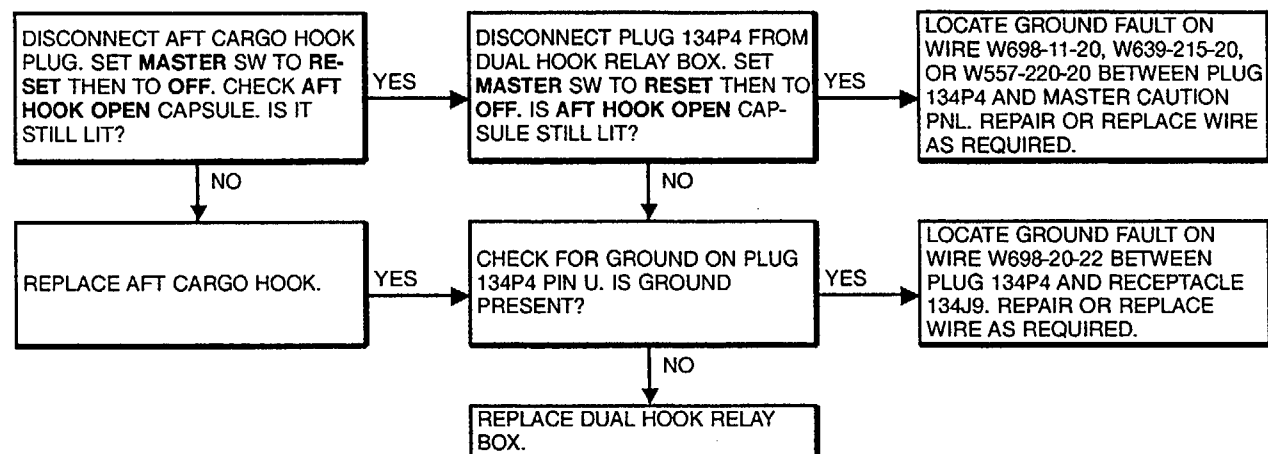

16-1.14 DUAL HOOK FAULT CAPSULE LIT

FAULT ISOLATION PROCEDURE

INITIAL SETUP

Applicable Configurations

All

Tools

Electrical Repairer's Tool Kit,
NSN 5180-00-3234915
Multimeter

Materials:

None

Personnel Required:

Aircraft Electrician

References

TM 55-1520-240-23

Equipment Condition:

TM 55-1520-240-23:

Battery Connected

Electrical Power On

Hydraulic Power Off

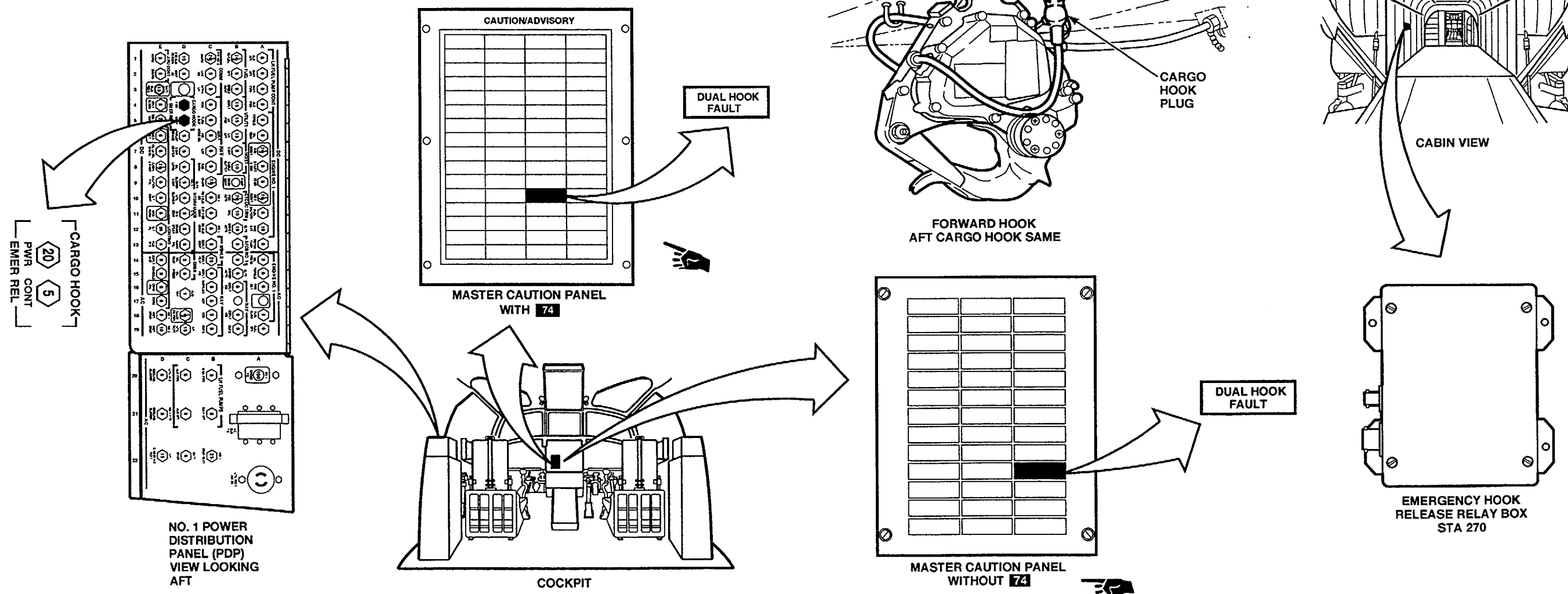

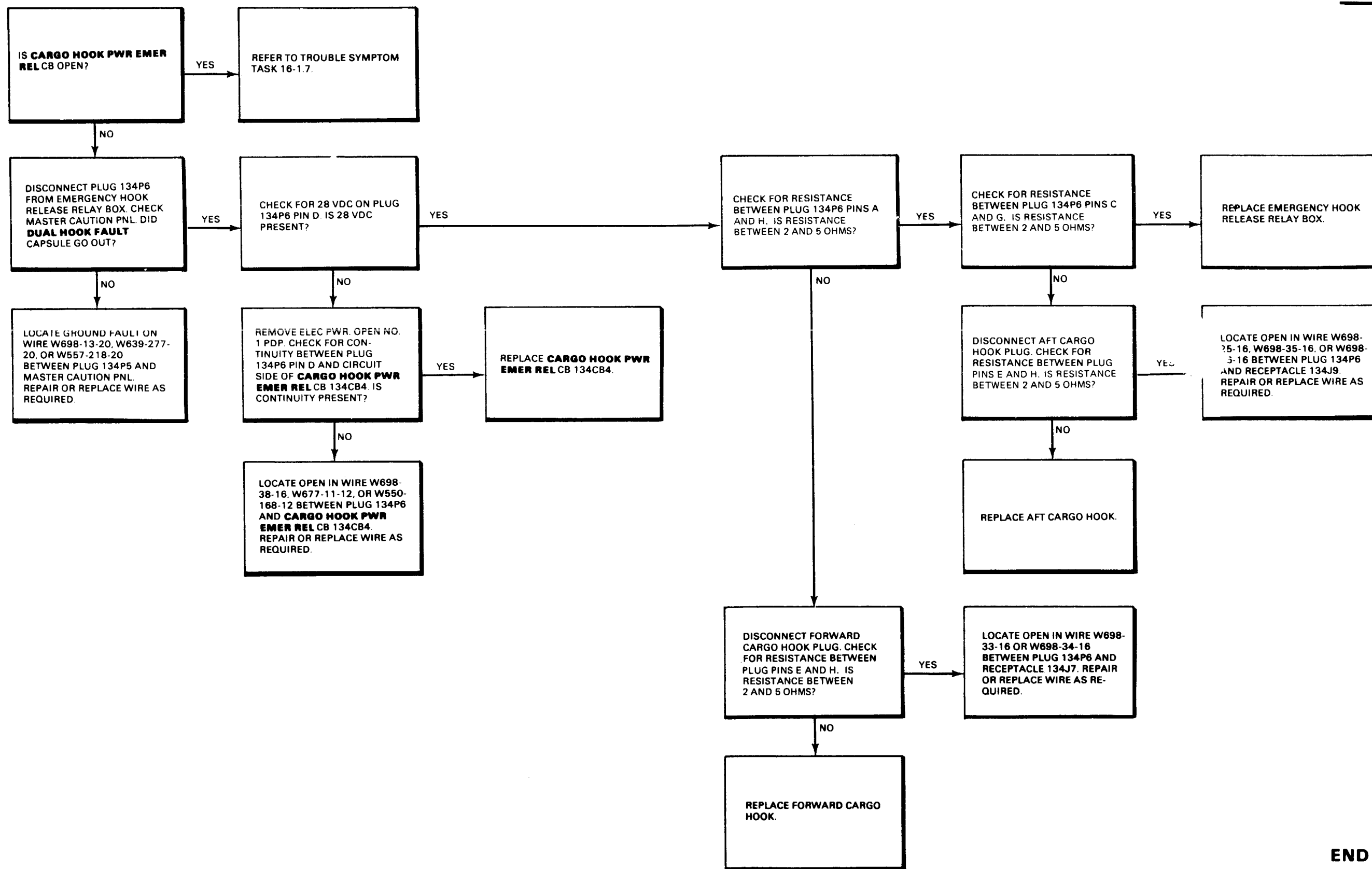

END OF TASK

16-1.15 DUAL HOOK RELAY BOX LIGHT(S) DO NOT
COME ON WHEN PRESSED

FAULT ISOLATION PROCEDURE

INITIAL SETUP

Applicable Configurations:
All

Tools:
Electrical Repairer's Tool Kit,
NSN 5180-00-323-4915
Multimeter

Materials:
None

Personnel Required:
68F20 Aircraft Electrician

References:
TM 55-1520-240-23

Equipment Condition:
TM 55-1520-240-23:
Battery Connected
Electrical Power On
Hydraulic Power Off

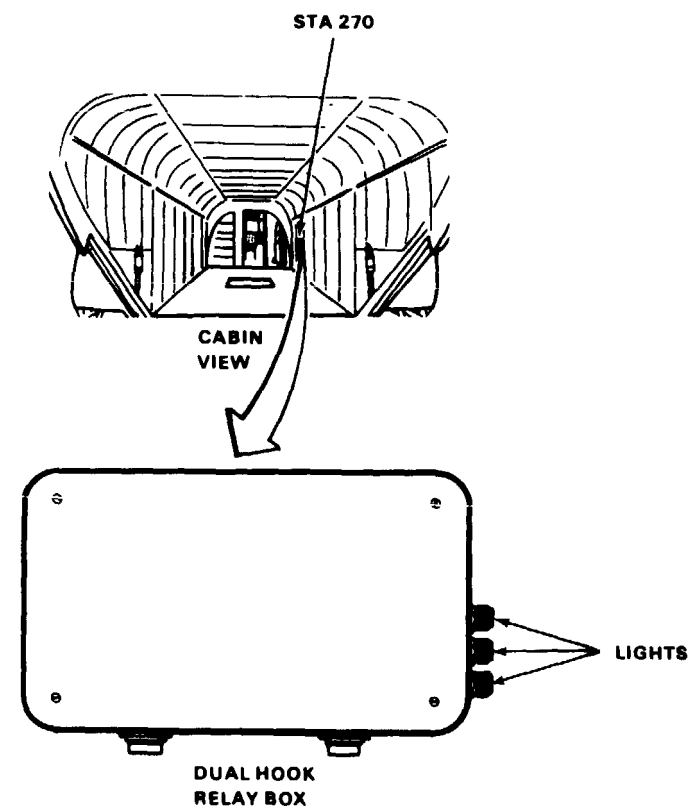
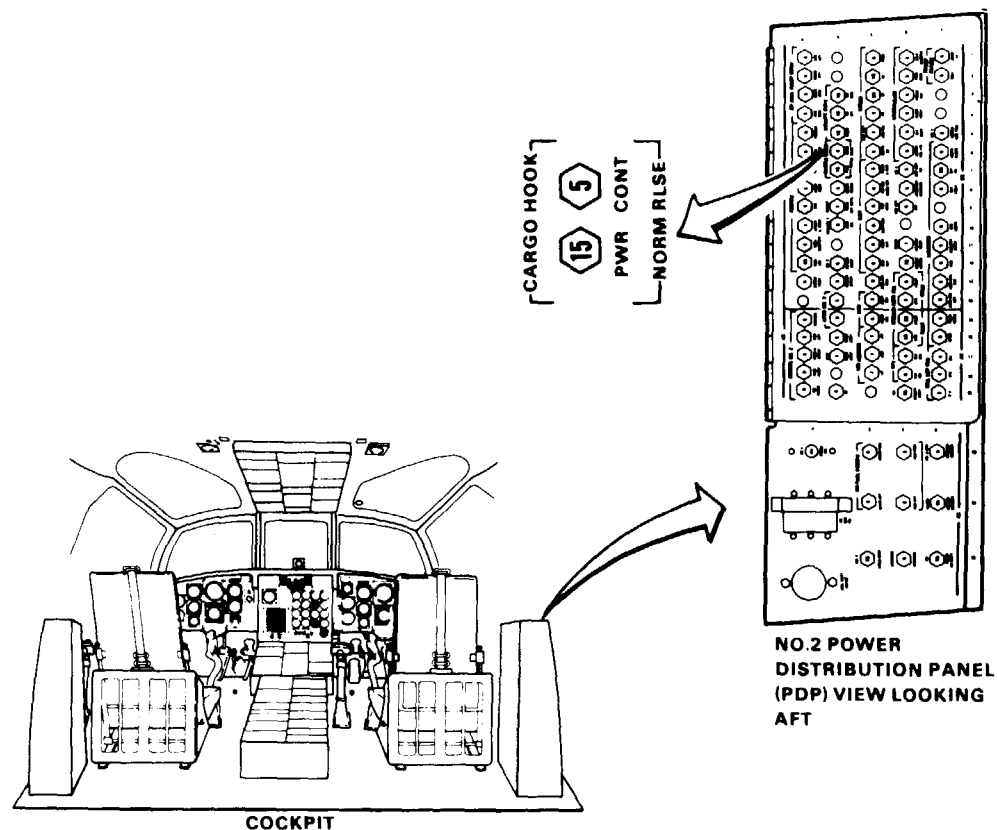

16-1.15 DUAL HOOK RELAY BOX LIGHT(S) DO NOT COME ON WHEN PRESSED (Continued)

16-1.15

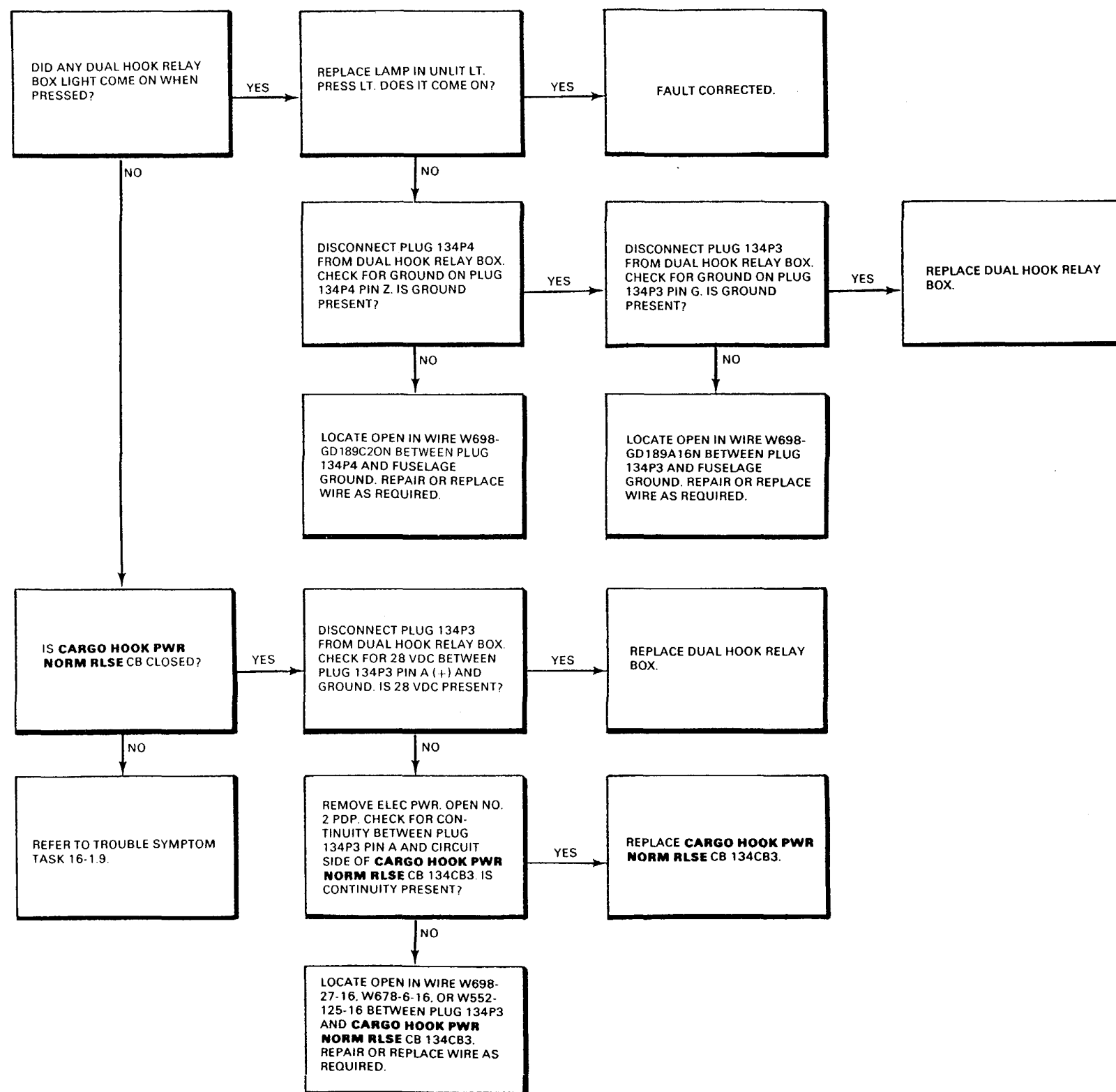

END OF TASK

16-1.16 DUAL HOOK FAULT LIGHT DOES NOT COME ON WITH HOOK DISCONNECTED

FAULT ISOLATION PROCEDURE

INITIAL SETUP

Applicable Configurations:

All

Tools: TM 55-1520-240-23
Electrical Repairer's Tool Kit,
NSN 5180-00-323-4915
Multimeter

Materials:
None

Personnel Required:

Aircraft Electrician

References

Equipment Condition:

TM 55-1520-240-23:
Battery Connected
Electrical Power On
Hydraulic Power Off

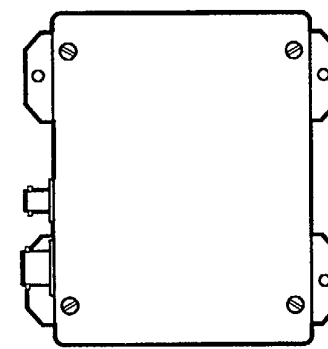

EMERGENCY HOOK
RELEASE RELAY BOX
STA 270

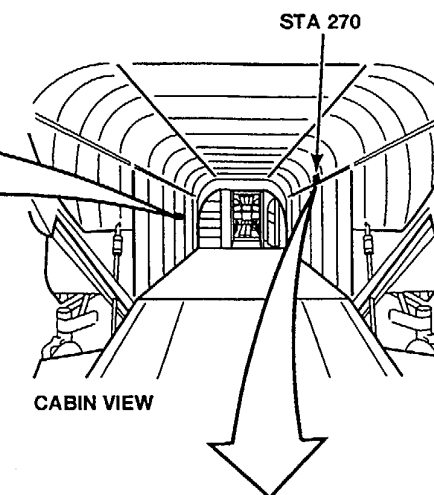

CABIN VIEW

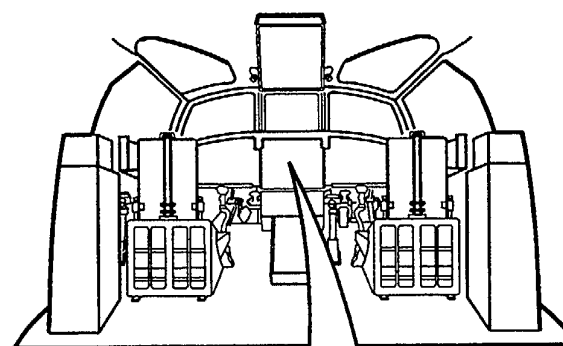

COCKPIT

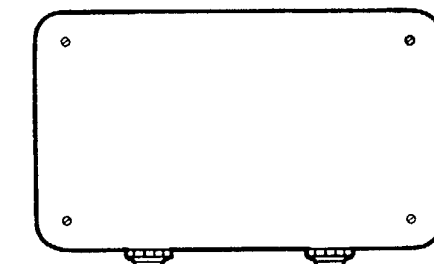

DUAL HOOK
RELAY BOX

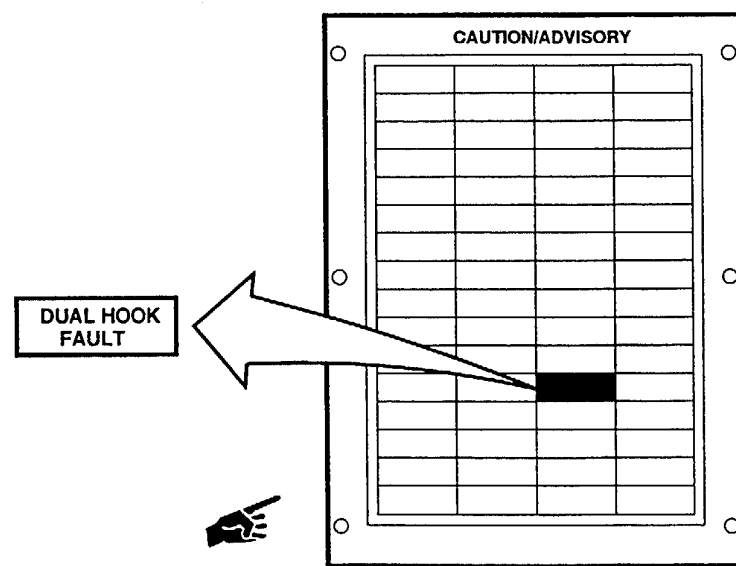

DUAL HOOK
FAULT

MASTER CAUTION PANEL
WITH 74

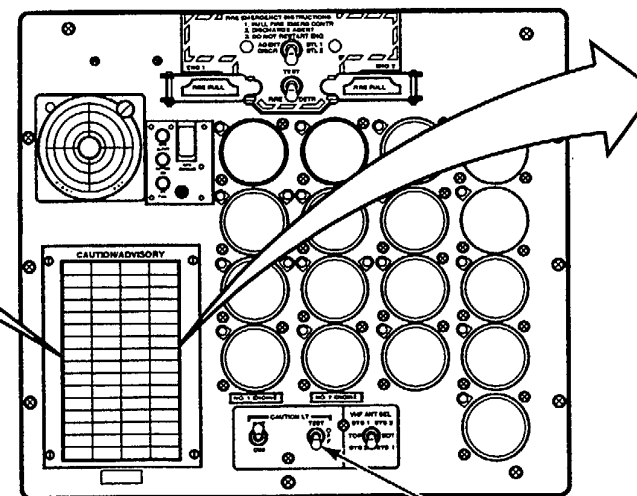

CENTER INSTRUMENT
PANEL

CAUTION LIGHTS
TEST SWITCH

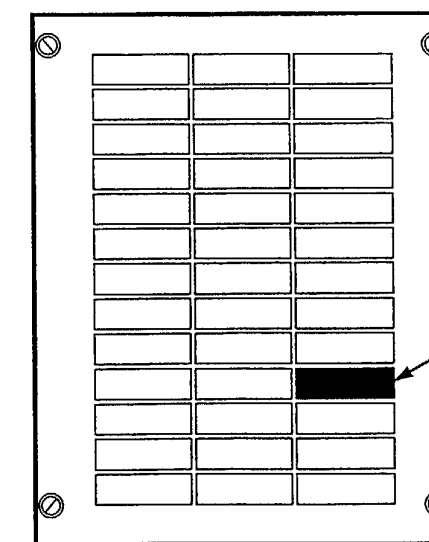

DUAL HOOK
FAULT CAPSULE

MASTER CAUTION PANEL
WITHOUT 74

A65535

16-1.16 DUAL HOOK FAULT LIGHT DOES NOT COME ON WITH HOOK DISCONNECTED (Continued)

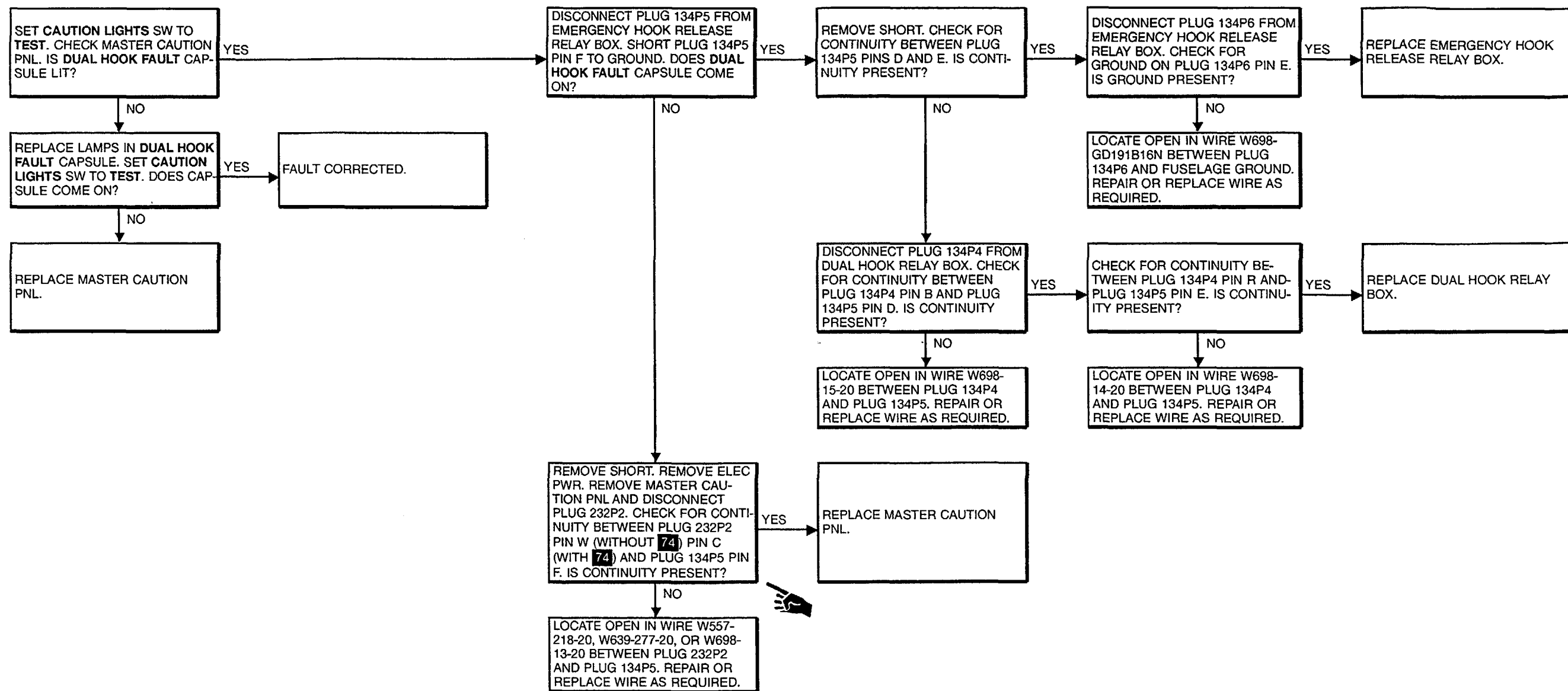

END OF TASK

16-1.17 ARMED SW FAIL LIGHT DOES NOT COME ON WITH MASTER SWITCH AT ARM

FAULT ISOLATION PROCEDURE

INITIAL SETUP

Applicable Configurations
All

Tools
Electrical Repairer's Tool Kit.
NSN 5180-00-323-4915
Multimeter

Materials
None

Personnel Required:
Aircraft Electrician

References
TM 55-1520-240-23

Equipment Condition:
TM 55-1520-240-23:
Battery Connected
Electrical Power On
Hydraulic Power Off

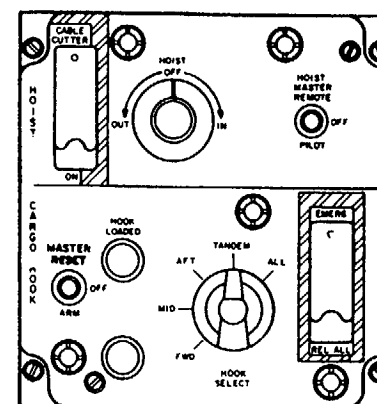
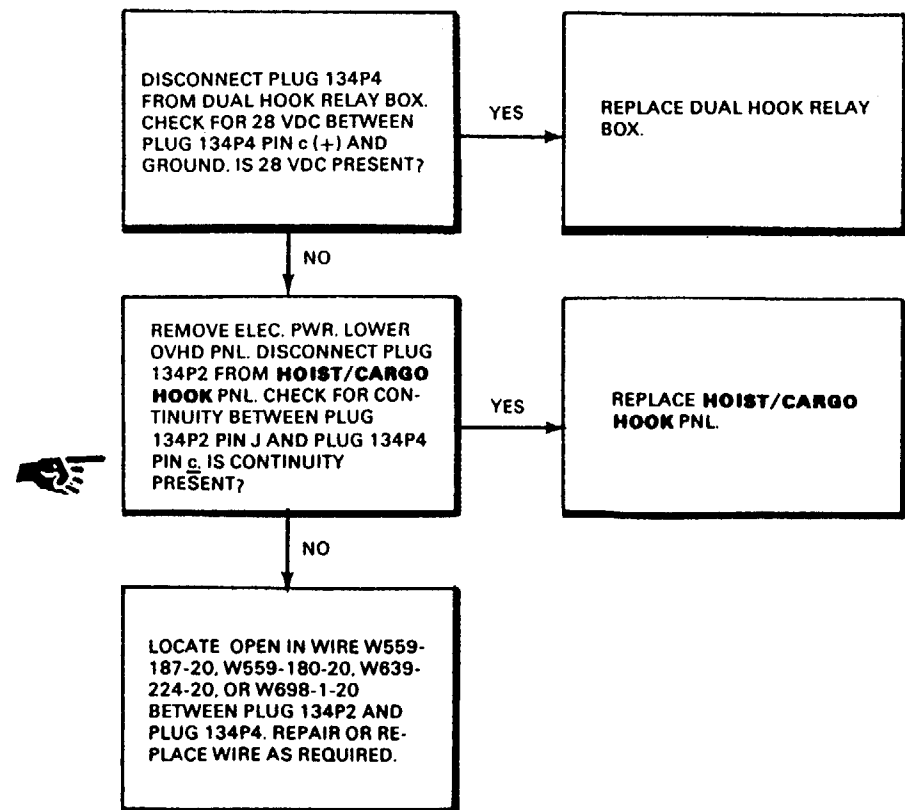

HOIST/CARGO HOOK PANEL

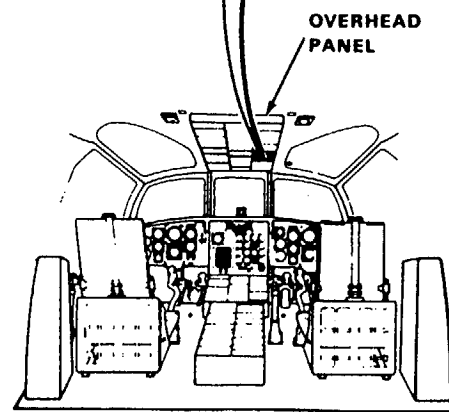

COCKPIT

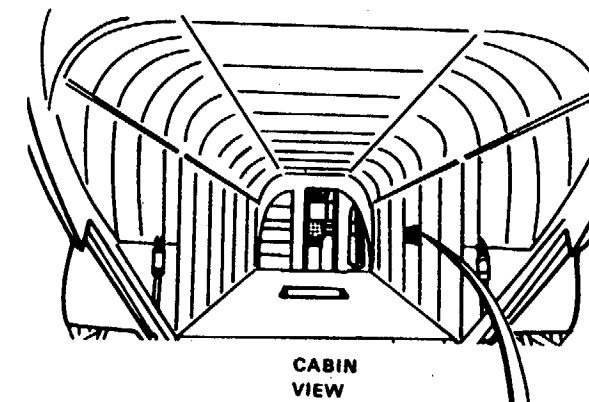

CABIN VIEW

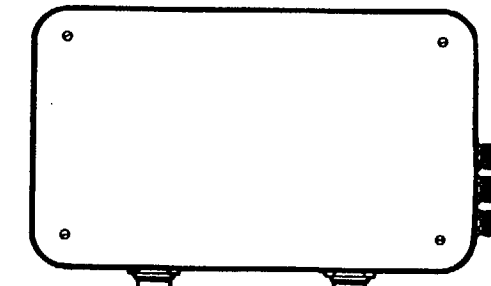

DUAL HOOK RELAY BOX STA 270

16-1.18 RELEASE SW FAIL LIGHT OR GROUND RELAY ACTIVATE LIGHT NOT ON WHEN PILOT'S CARGO HOOK RELEASE SWITCH PRESSED

FAULT ISOLATION PROCEDURE

INITIAL SETUP

Applicable Configurations:
All

Tools:
Electrical Repairer's Tool Kit,
NSN 5180-00-323-4915
Multimeter

Materials:
None

Personnel Required:
68F20 Aircraft Electrician

References:
TM 55-1520-240-23

Equipment Condition:
TM 55-1520-240-23:
Battery Connected
Electrical Power On
Hydraulic Power Off

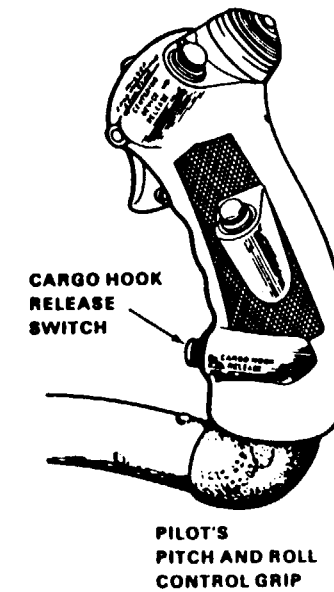
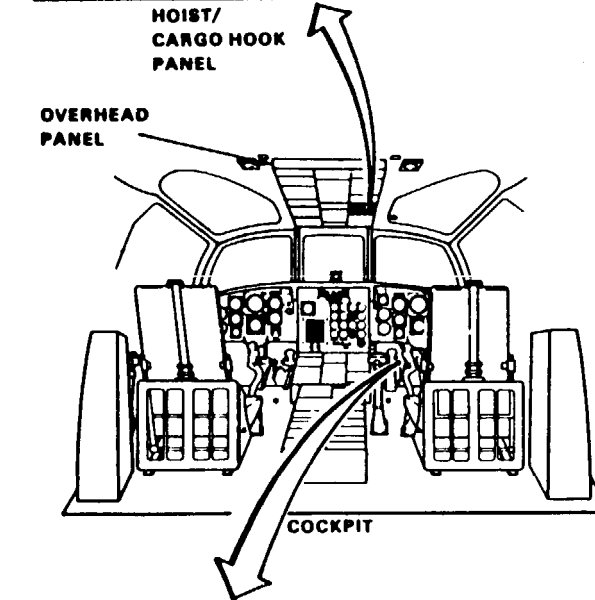
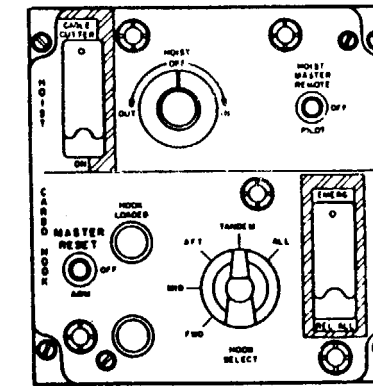
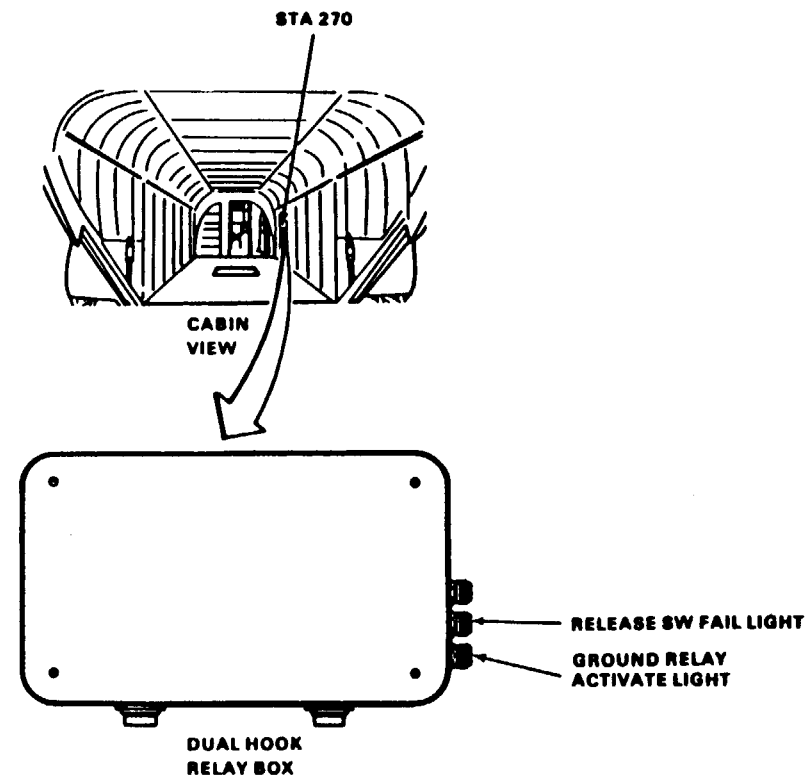

16-1.18 RELEASE SW FAIL LIGHT OR GROUND RELAY ACTIVATE LIGHT NOT ON WHEN PILOT'S CARGO HOOK RELEASE SWITCH PRESSED (Continued)

16-1.18

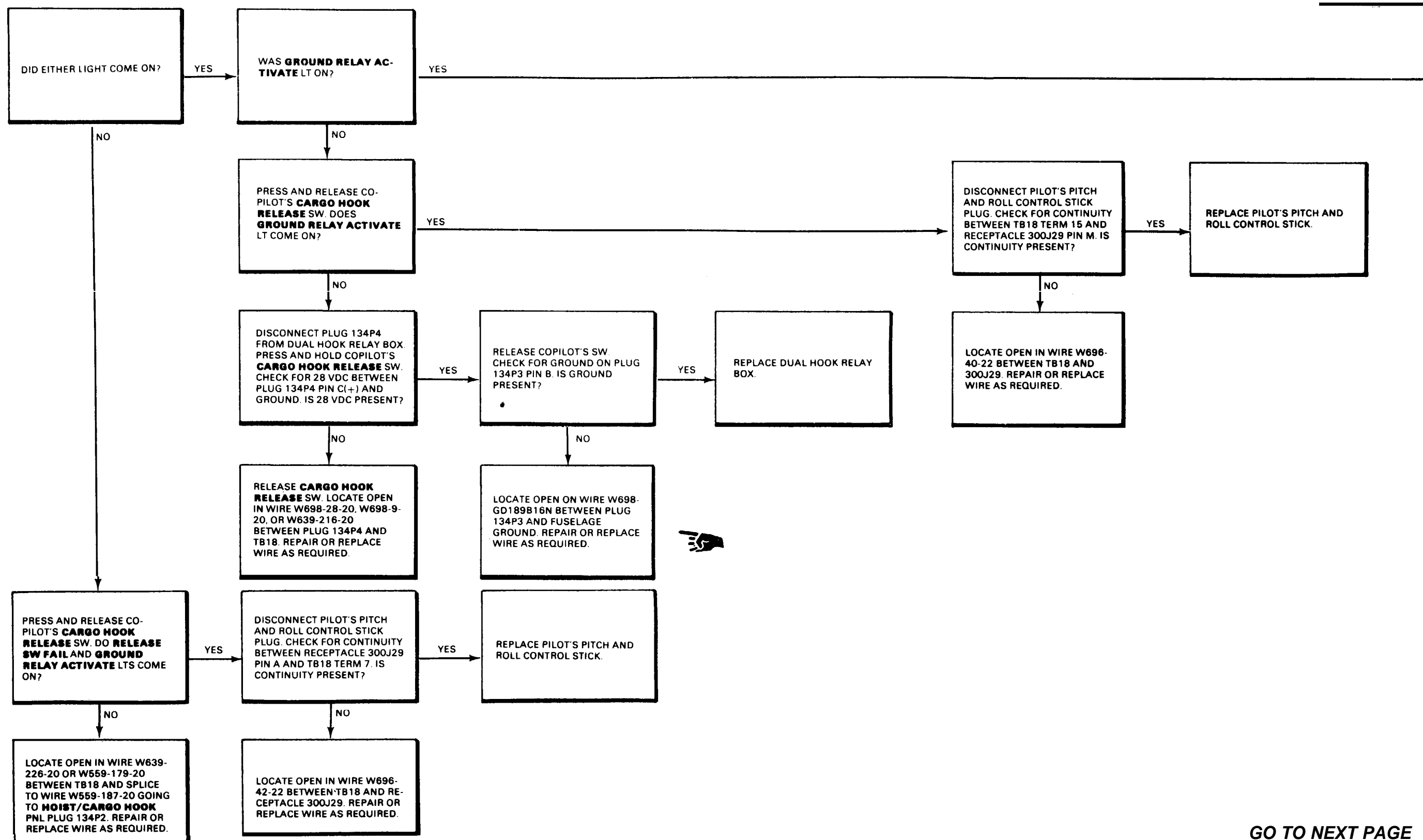

GO TO NEXT PAGE

16-1.18 RELEASE SW FAIL LIGHT OR GROUND RELAY ACTIVATE LIGHT NOT ON WHEN PILOT CARGO HOOK RELEASE SWITCH PRESSED (Continued)

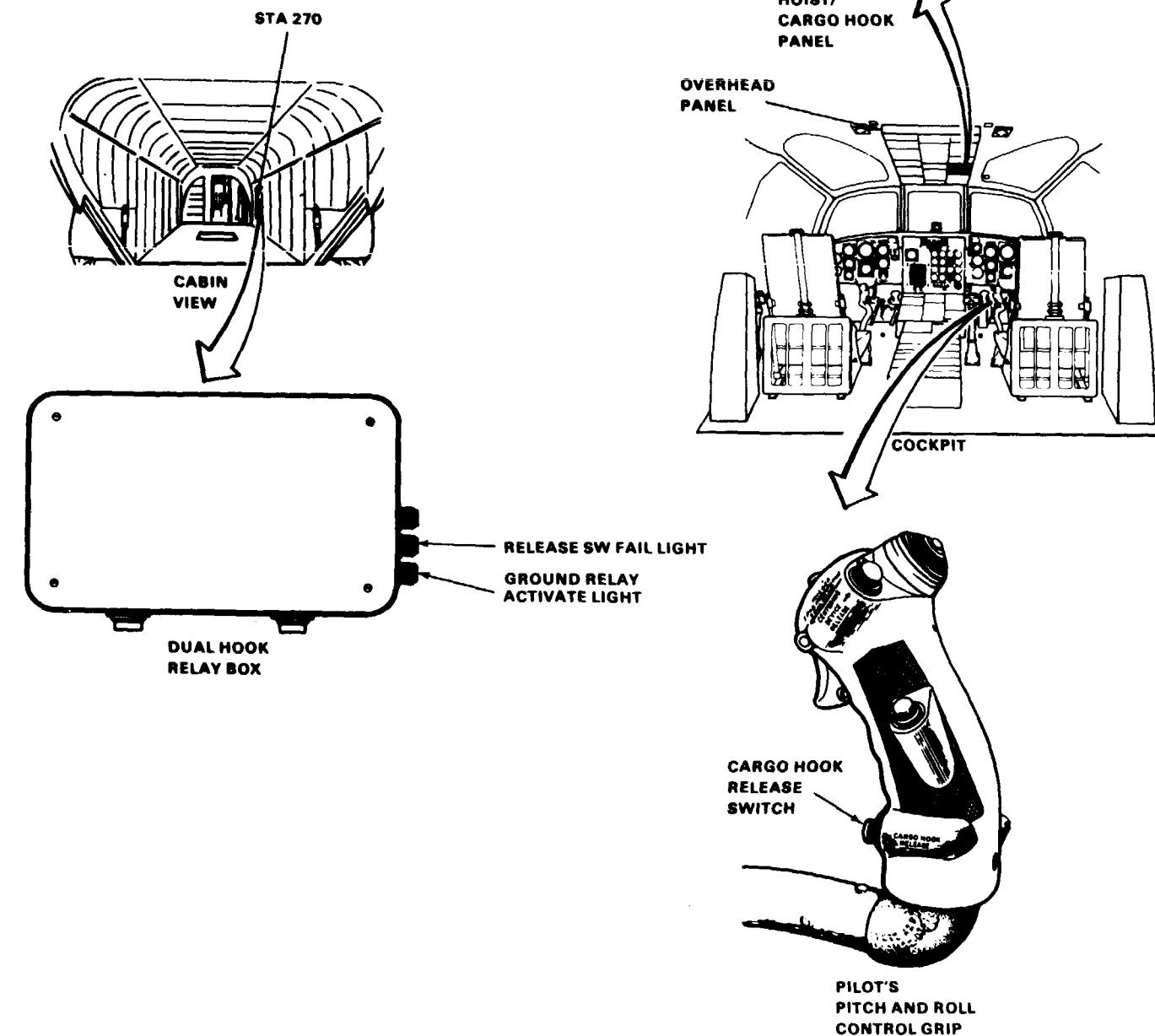
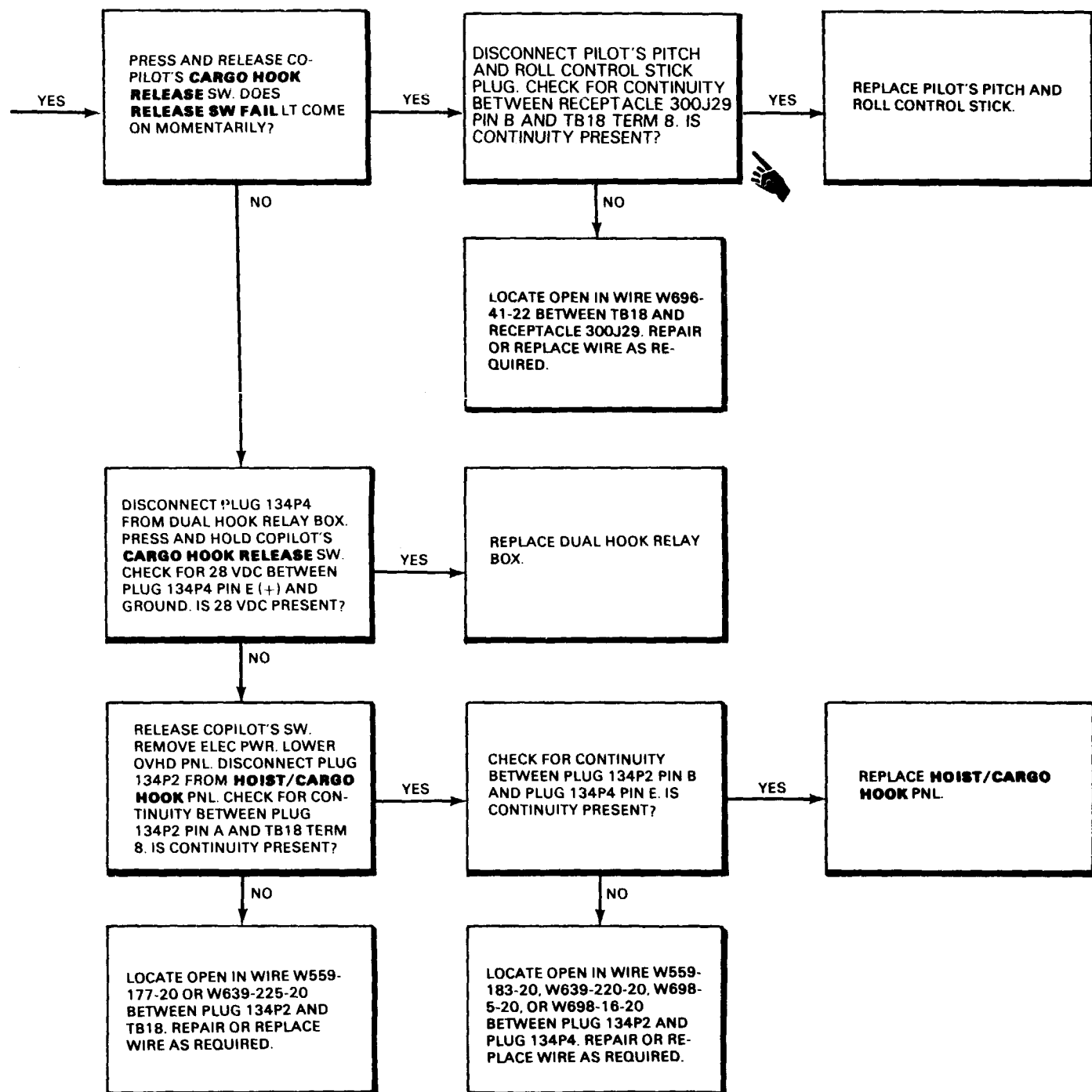

16-1.19 RELEASE SW FAIL LIGHT OR GROUND RELAY
 ACTIVATE LIGHT NOT ON WHEN COPILOT'S CARGO
 HOOK RELEASE SWITCH PRESSED

16-1.19

FAULT ISOLATION PROCEDURE

INITIAL SETUP

Applicable Configurations:
 All

Tools:
 Electrical Repairer's Tool Kit,
 NSN 5180-00-323-4915
 Multimeter

Materials:
 None

Personnel Required:
 68F20 Aircraft Electrician

References:
 TM 55-1520-240-23

Equipment Condition:
 TM 55-1520-240-23:
 Battery Disconnected
 Electrical Power Off
 Hydraulic Power Off

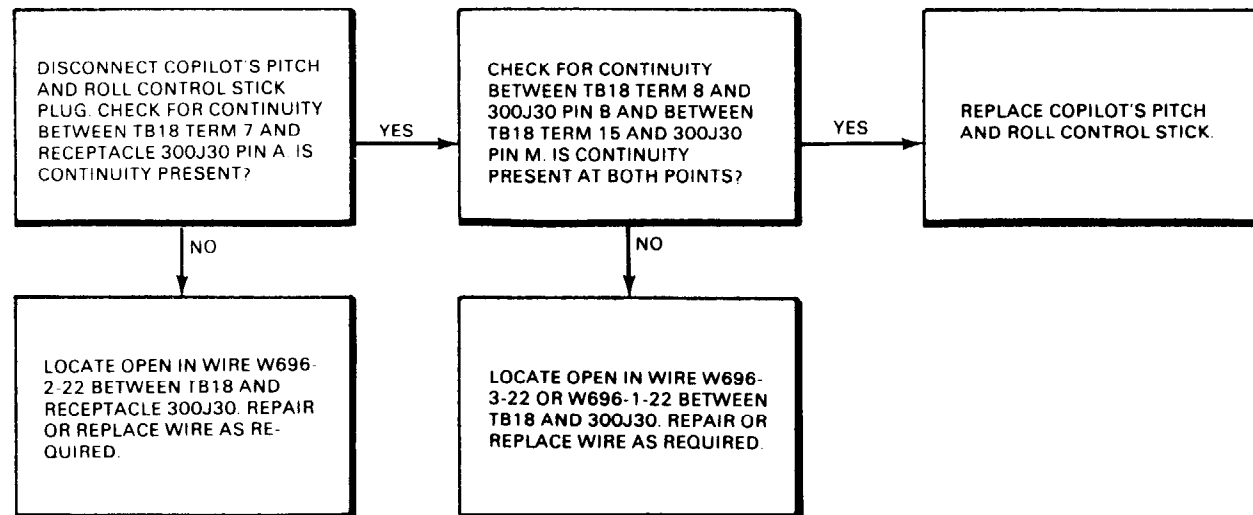
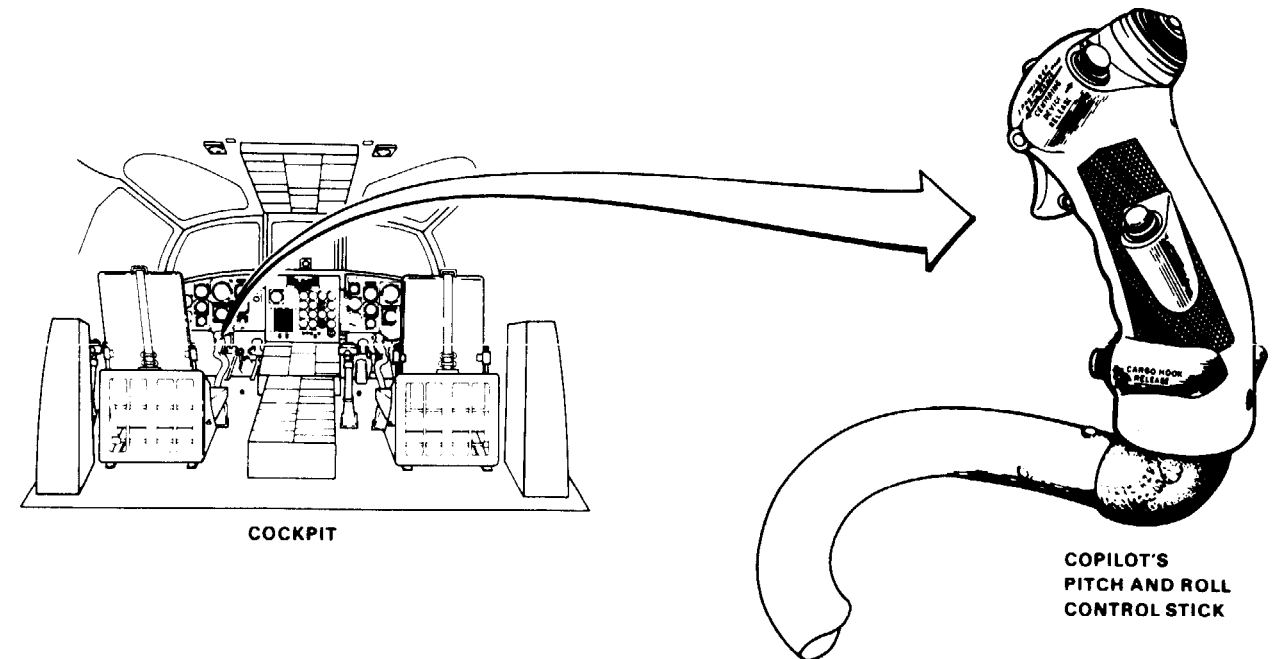

45x54

D145-6369-SPA

END OF TASK

16-49

FAULT ISOLATION PROCEDURE

INITIAL SETUP

Applicable Configurations:

All

Tools:

- Electrical Repairer's Tool Kit, NSN 5180-00-323-4915
- Multimeter

Materials:

None

Personnel Required:

Aircraft Electrician

References:

TM 55-1520-240-23

Equipment Condition:

- TM 55-1520-240-23:
- Battery Connected
- Electrical Power On
- Hydraulic Power Off

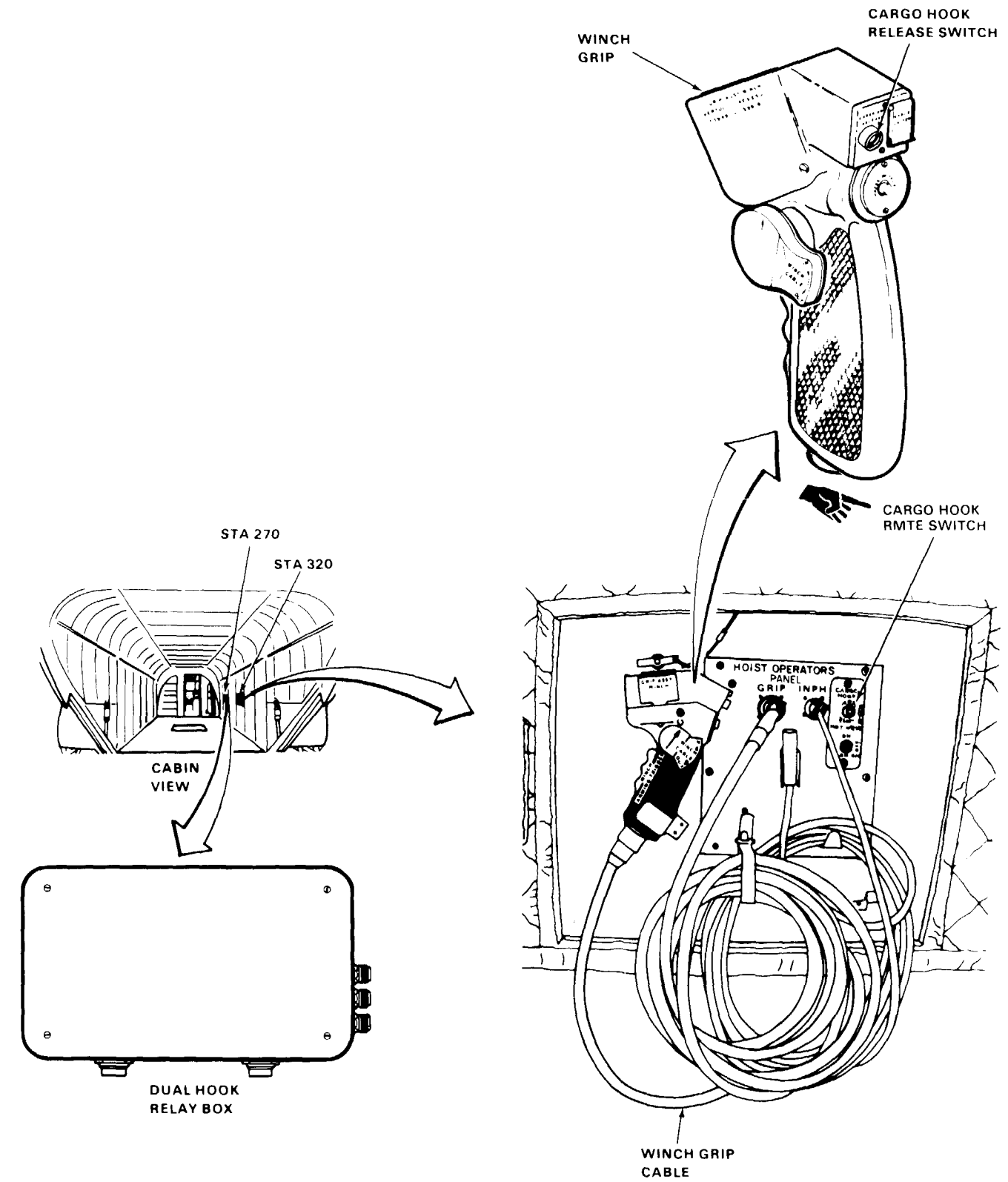

16-1.20 RELEASE SW FAIL LIGHT OR GROUND RELAY ACTIVATE
 LIGHT NOT ON WHEN HOIST OPERATOR'S CARGO HOOK
 RELEASE SWITCH PRESSED (Continued)

16-1.20

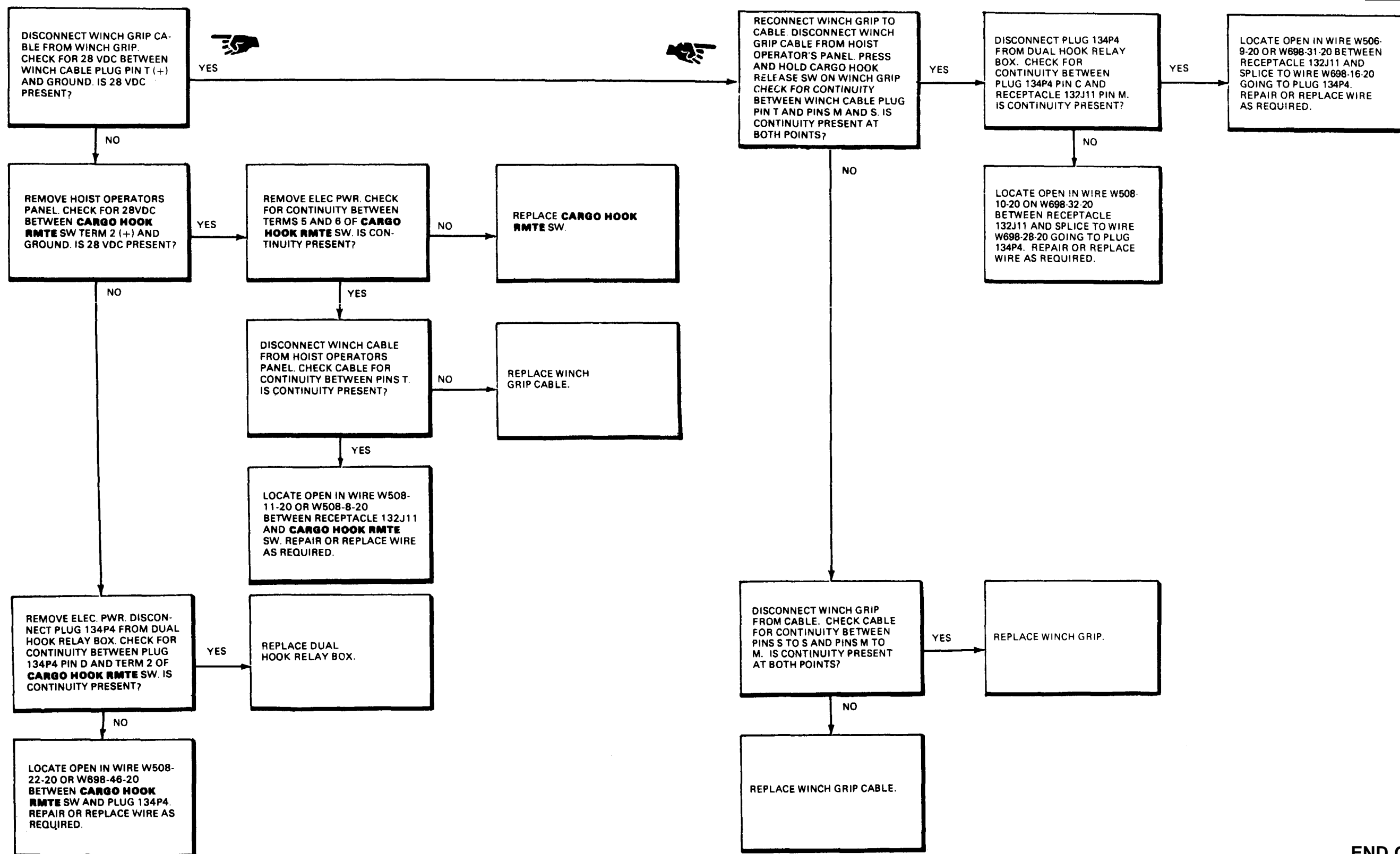

END OF TASK

FAULT ISOLATION PROCEDURE

INITIAL SETUP

Applicable Configurations:
All

Tools:
Electrical Repairer's Tool Kit,
NSN 5180-00-323-4915
Multimeter

Materials:
None

Personnel Required:
68F10 Aircraft Electrician
68F20 Aircraft Electrician

References:
TM 55-1520-240-23

Equipment Condition:
TM 55-1520-240-23:
Battery Connected
Electrical Power On
Hydraulic Power Off

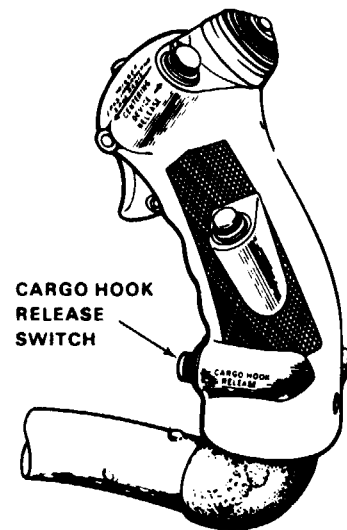
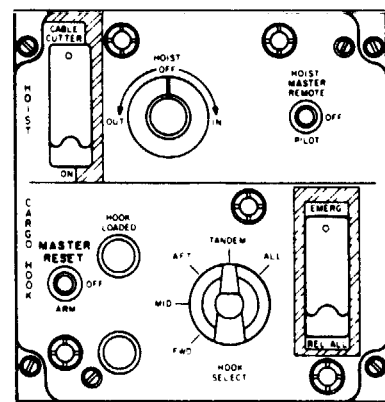
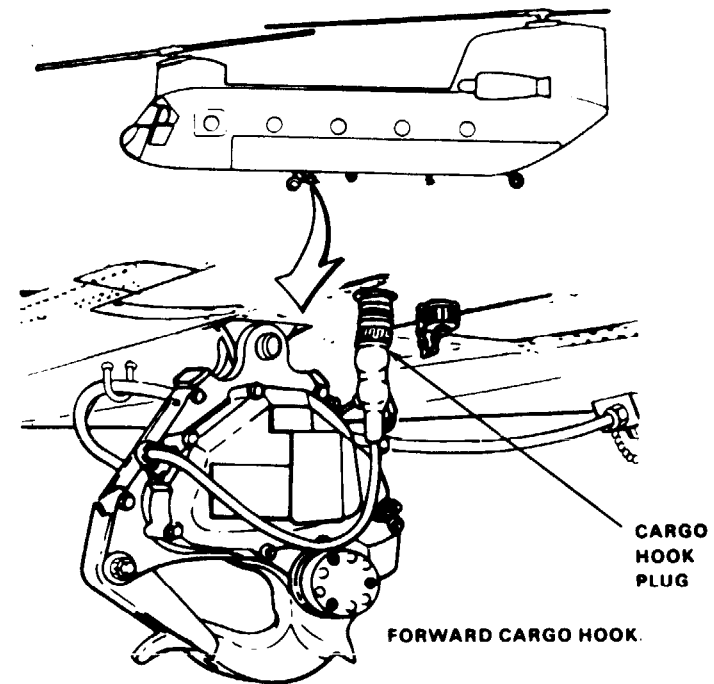

PILOT'S PITCH AND ROLL CONTROL GRIP

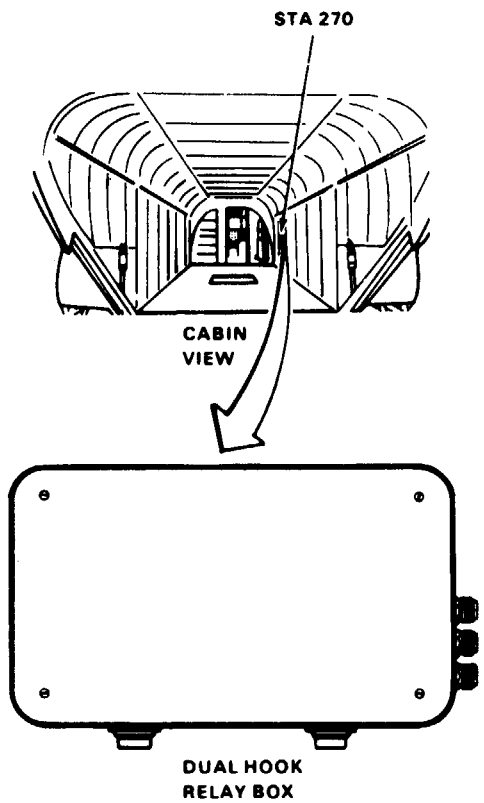
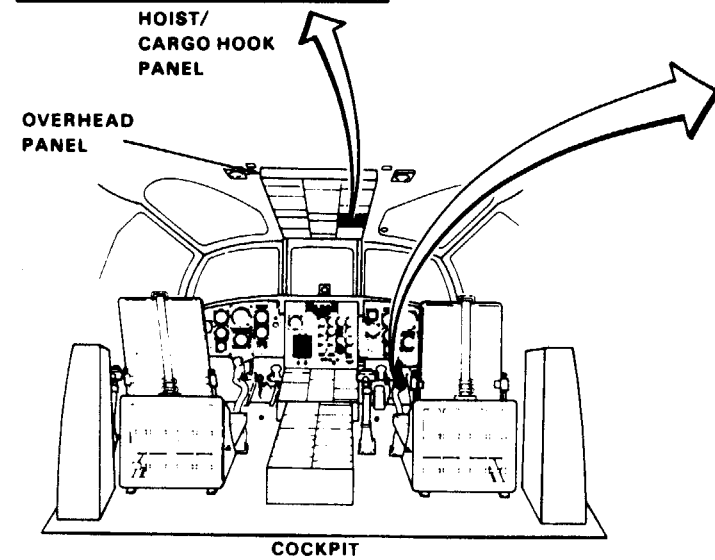

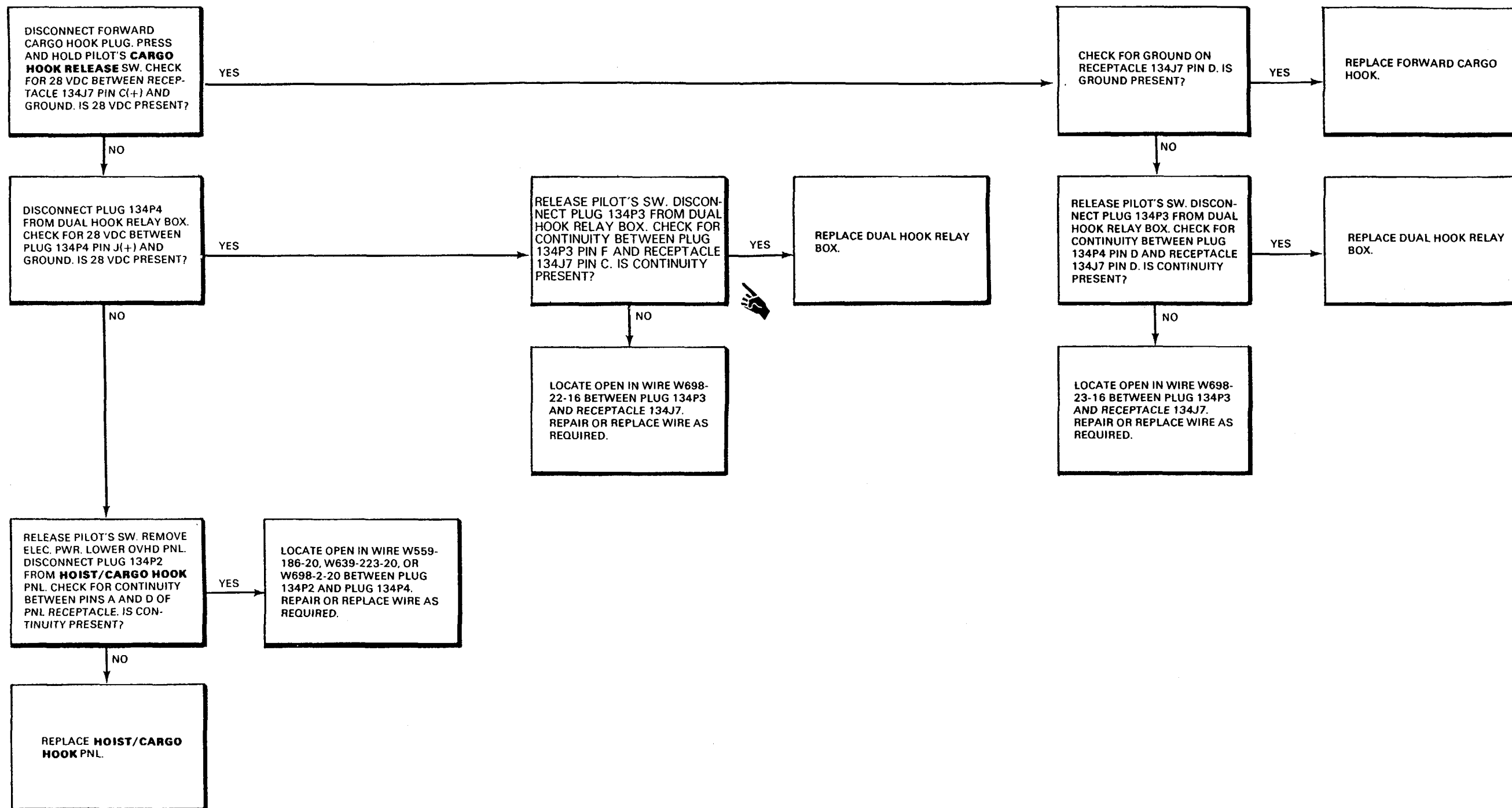

END OF TASK

Change 9 16-53

16-1.22 FWD HOOK OPEN CAPSULE DOES NOT COME ON WHEN FORWARD CARGO HOOK OPENS

FAULT ISOLATION PROCEDURE

INITIAL SETUP

Applicable Configurations
All

Tools
Electrical Repairer's Tool Kit,
NSN 5180-00-323-4915
Multimeter

Materials
None

Personnel Required:
Aircraft Electrician

References
TM 55-1520-240-23

Equipment Condition:
TM 55-1520-240-23:
Battery Connected
Electrical Power On
Hydraulic Power Off

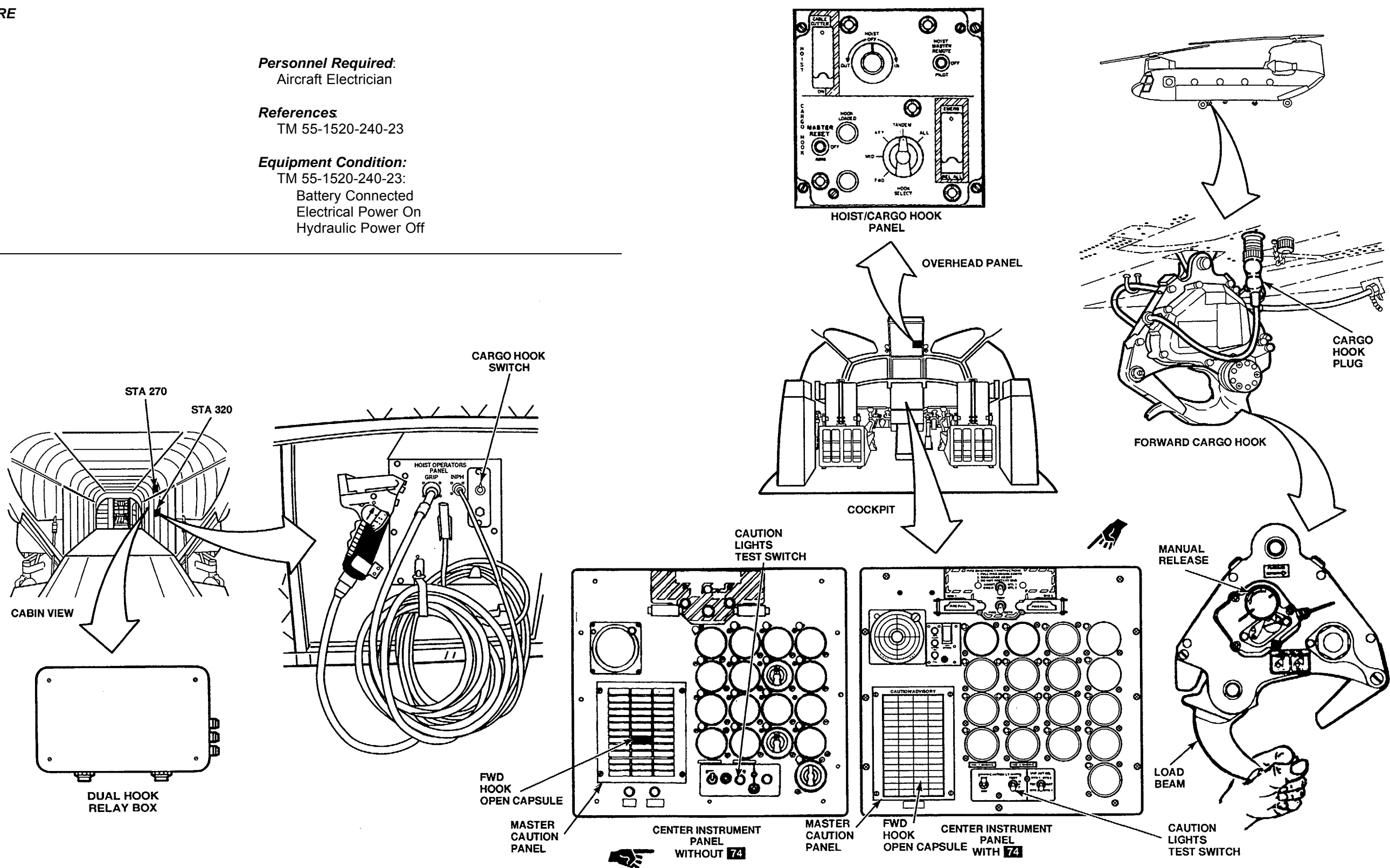

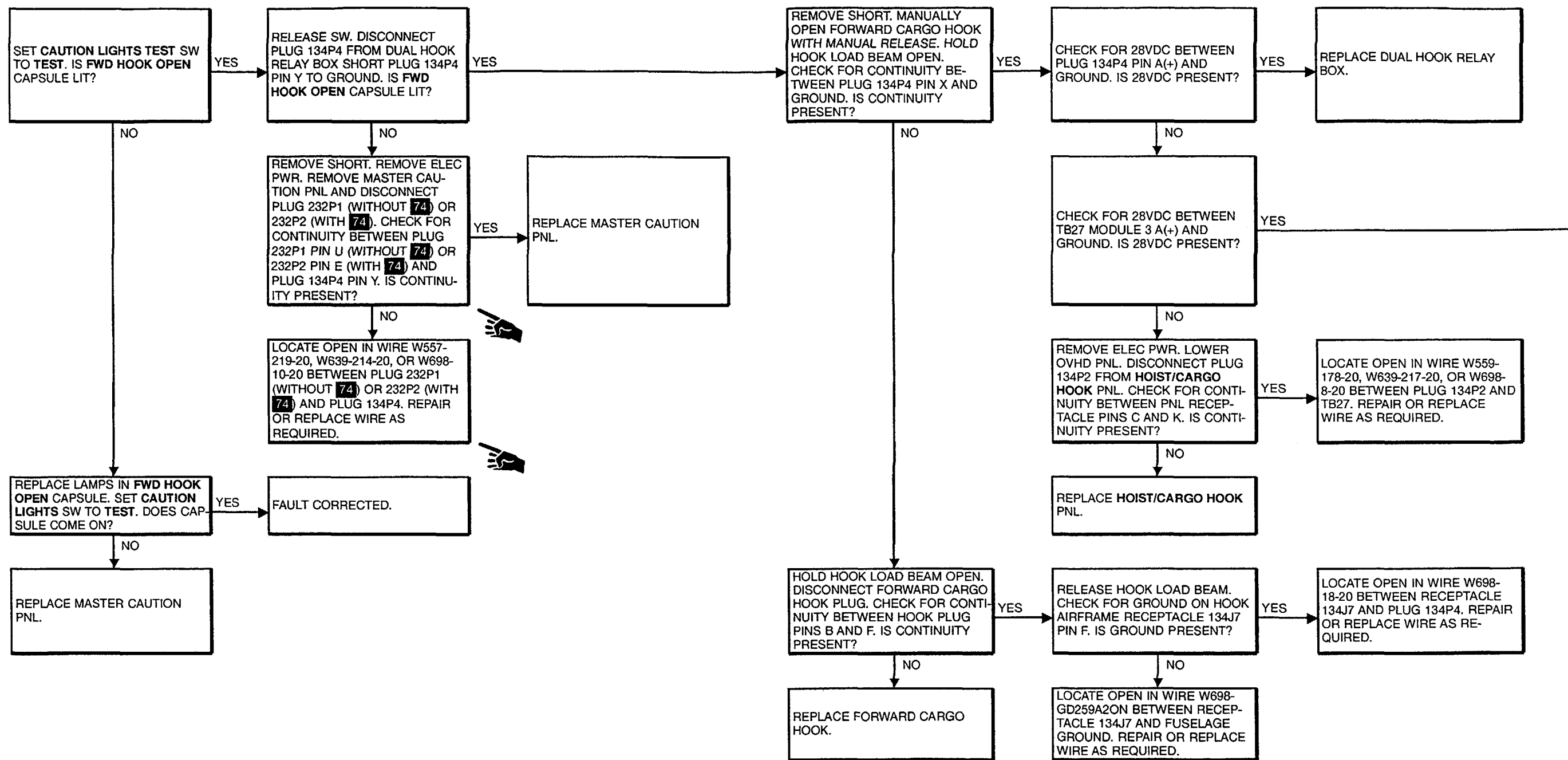

16-1.22 FWD HOOK OPEN CAPSULE DOES NOT COME ON WHEN FORWARD CARGO HOOK OPENS (Continued)

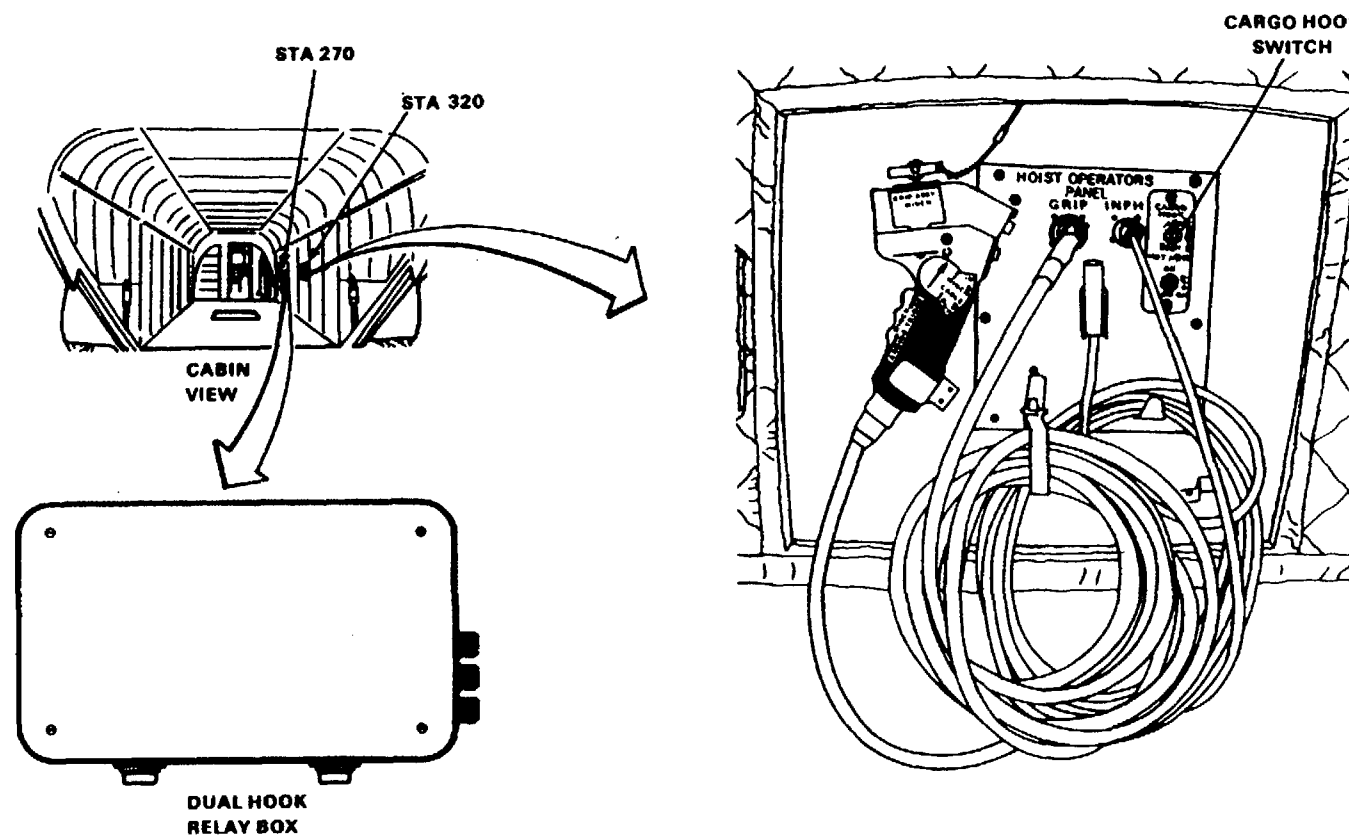
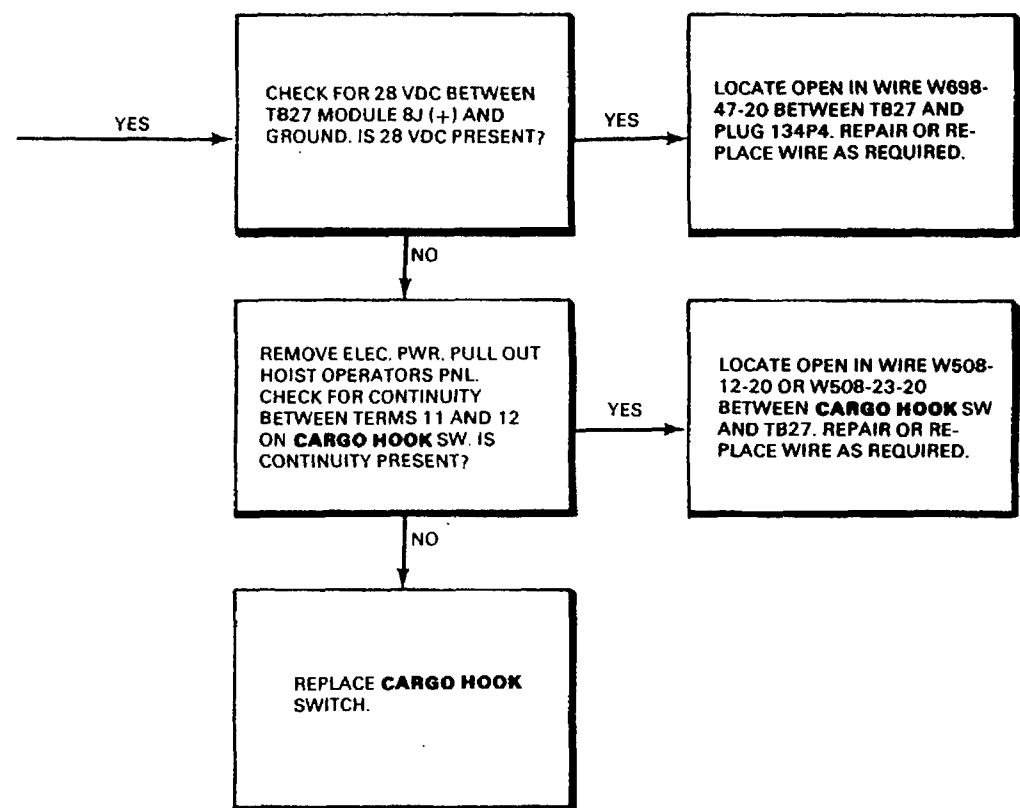

45x54

D145-10851-SPA

16-1.23 CENTER CARGO HOOK DOES NOT OPEN

FAULT ISOLATION PROCEDURE

INITIAL SETUP

Applicable Configurations:
All

Tools:
Electrical Repairer's Tool Kit,
NSN 5180-00-323-4915
Multimeter

Materials:
None

Personnel Required:
67U10 Medium Helicopter Repairer
68F20 Aircraft Electrician

References:
TM 55-1520-240-23

Equipment Condition:
TM 55-1520-240-23:
Battery Connected
Electrical Power On
Hydraulic Power On

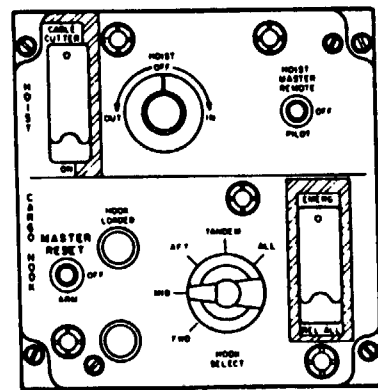

OVERHEAD PANEL

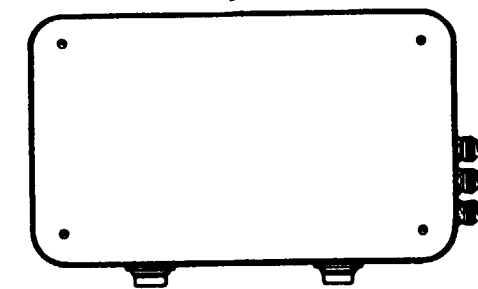
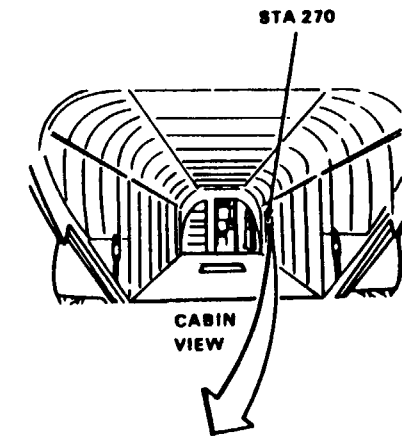
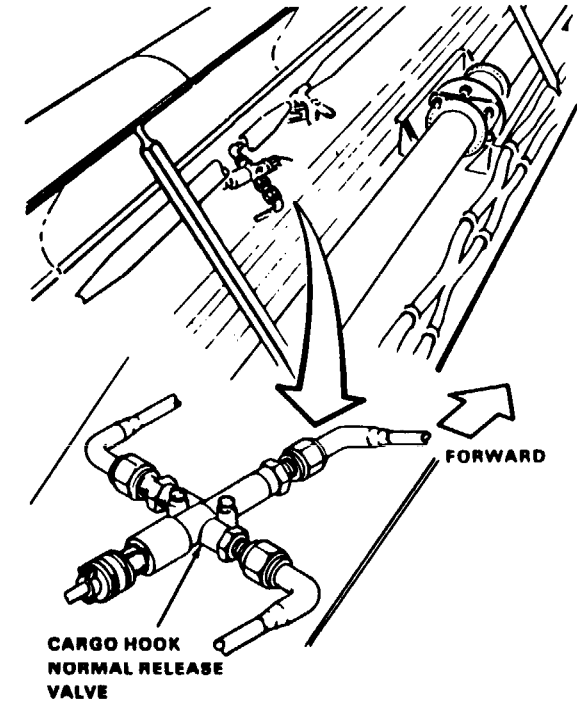
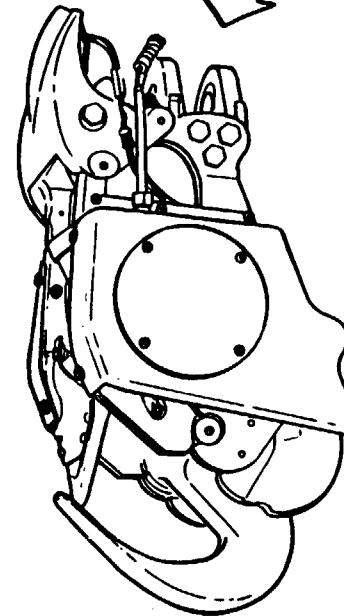
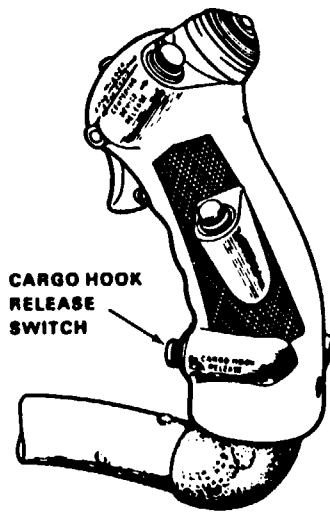
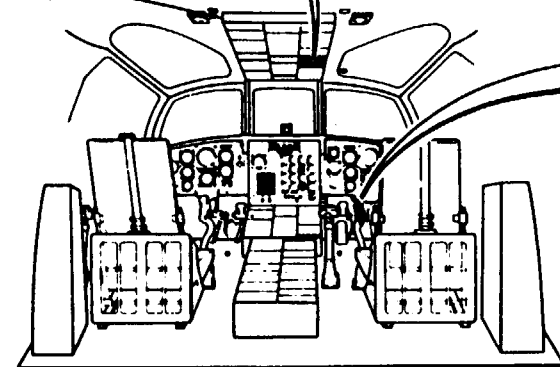

D145-6373-5PA

GO TO NEXT PAGE

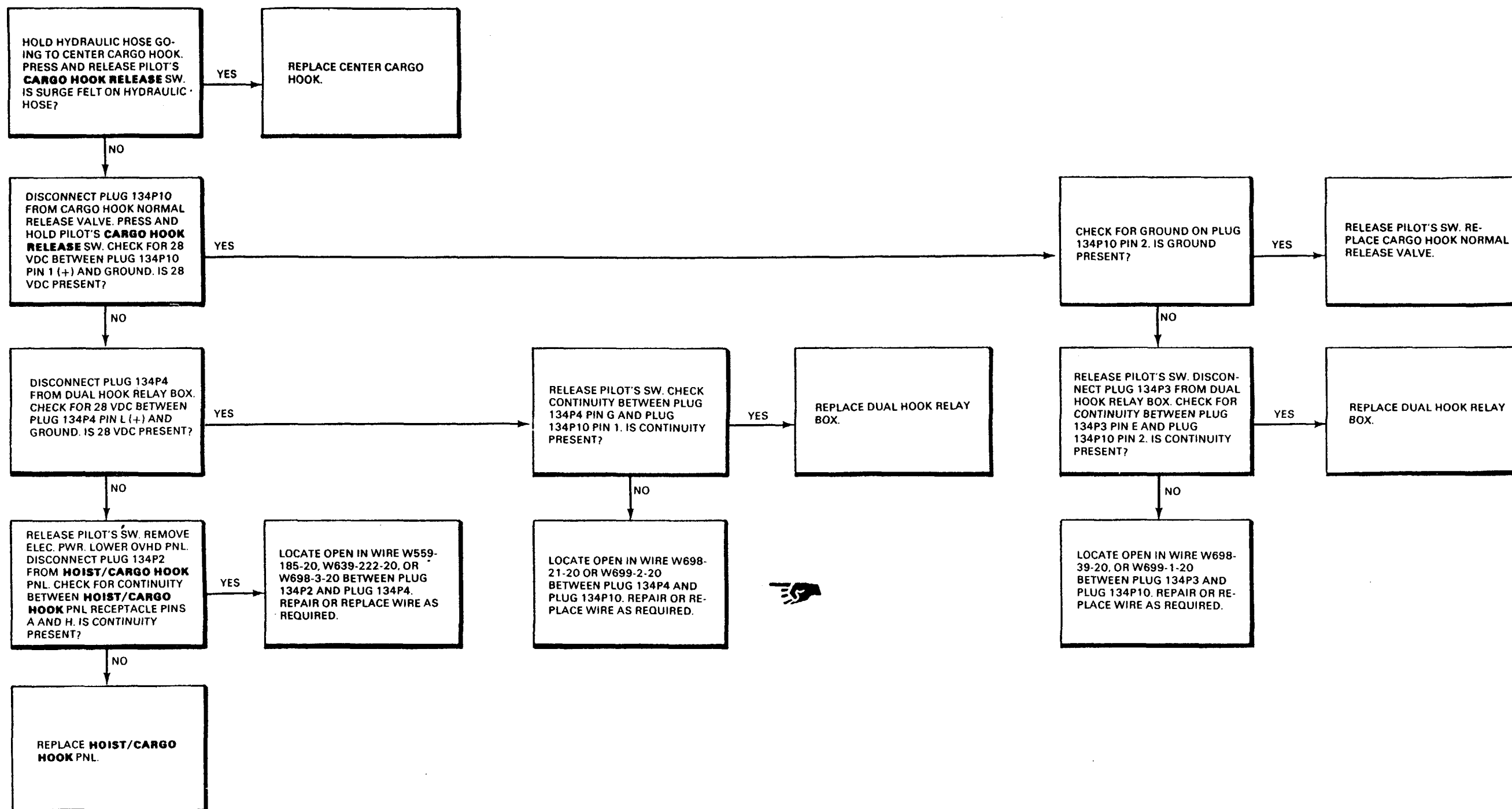

END OF TASK

Change 2 16-59

16-1.24 MID HOOK OPEN CAPSULE DOES NOT COME ON WHEN CENTER CARGO HOOK OPENS

FAULT ISOLATION PROCEDURE

INITIAL SETUP

Applicable Configurations

All

Tools

Electrical Repairer's Tool Kit,
NSN 5180-00-323-4915
Multimeter

Materials

None

Personnel Required:
Aircraft Electrician

References
TM 55-1520-240-23

Equipment Condition:
TM 55-1520-240-23:
Battery Connected
Electrical Power On
Hydraulic Power On

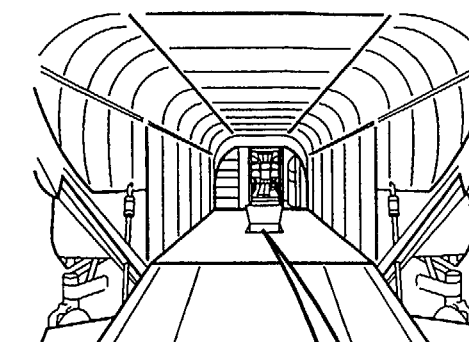

CABIN VIEW

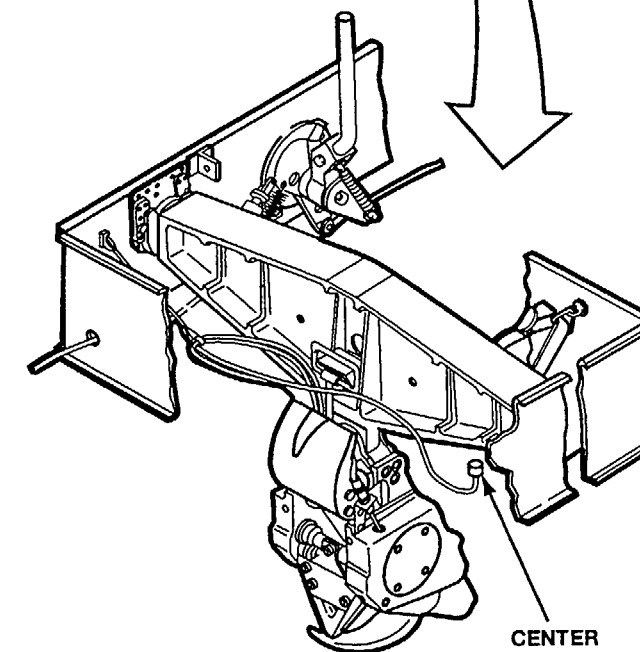
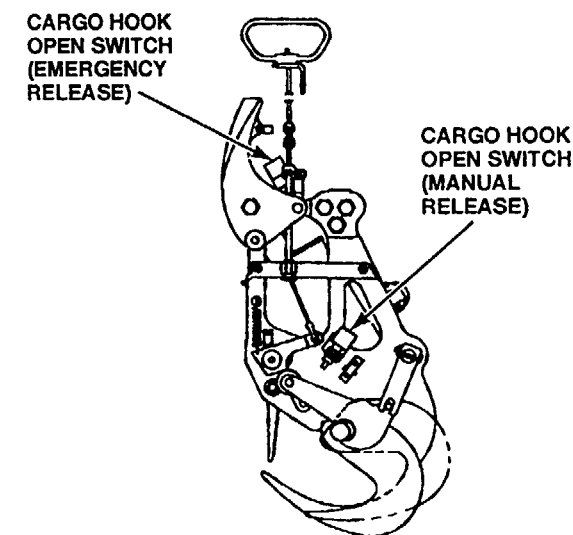

CENTER CARGO HOOK

CENTER CARGO HOOK PLUG

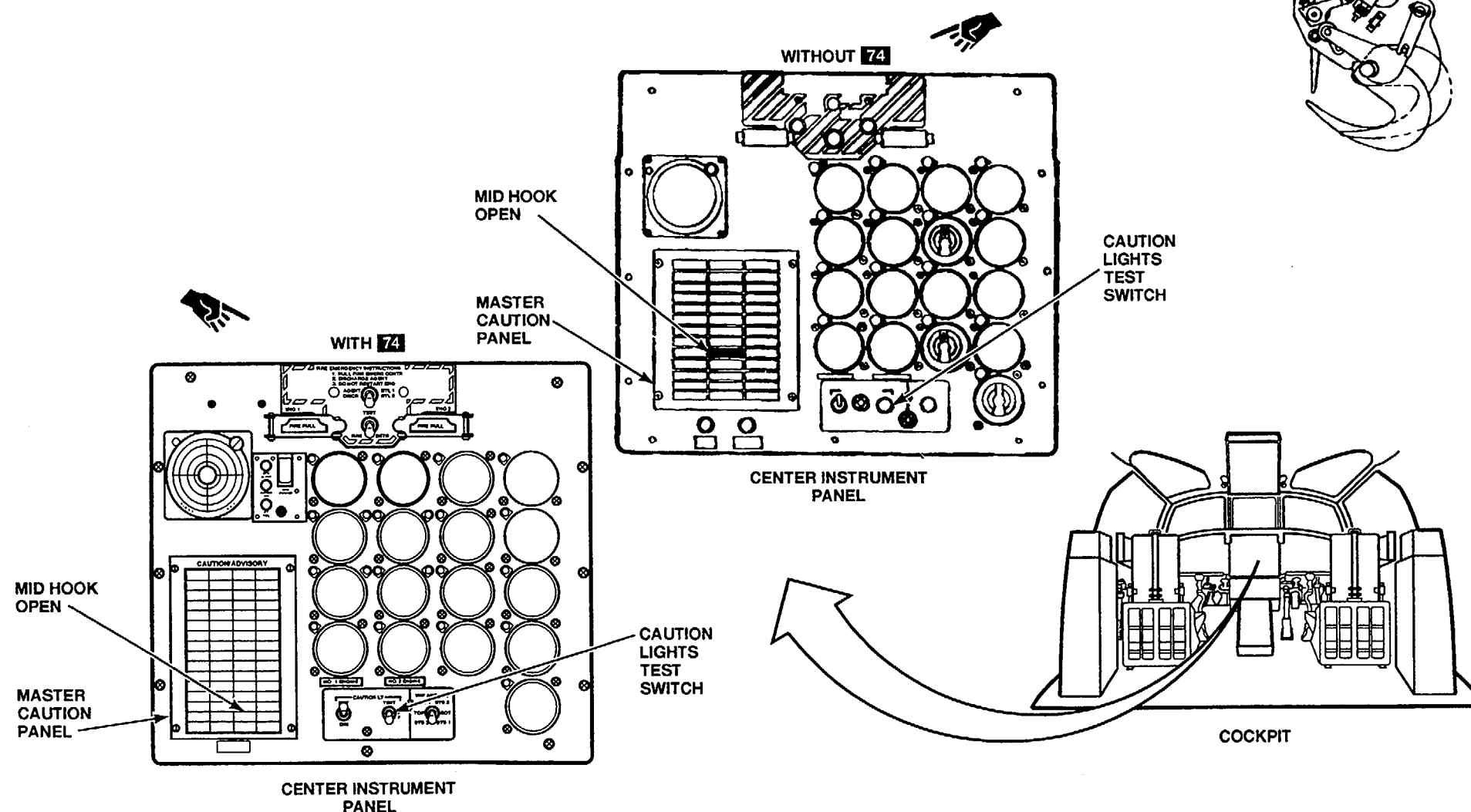

WITHOUT 74

WITH 74

CENTER INSTRUMENT PANEL

CENTER INSTRUMENT PANEL

COCKPIT

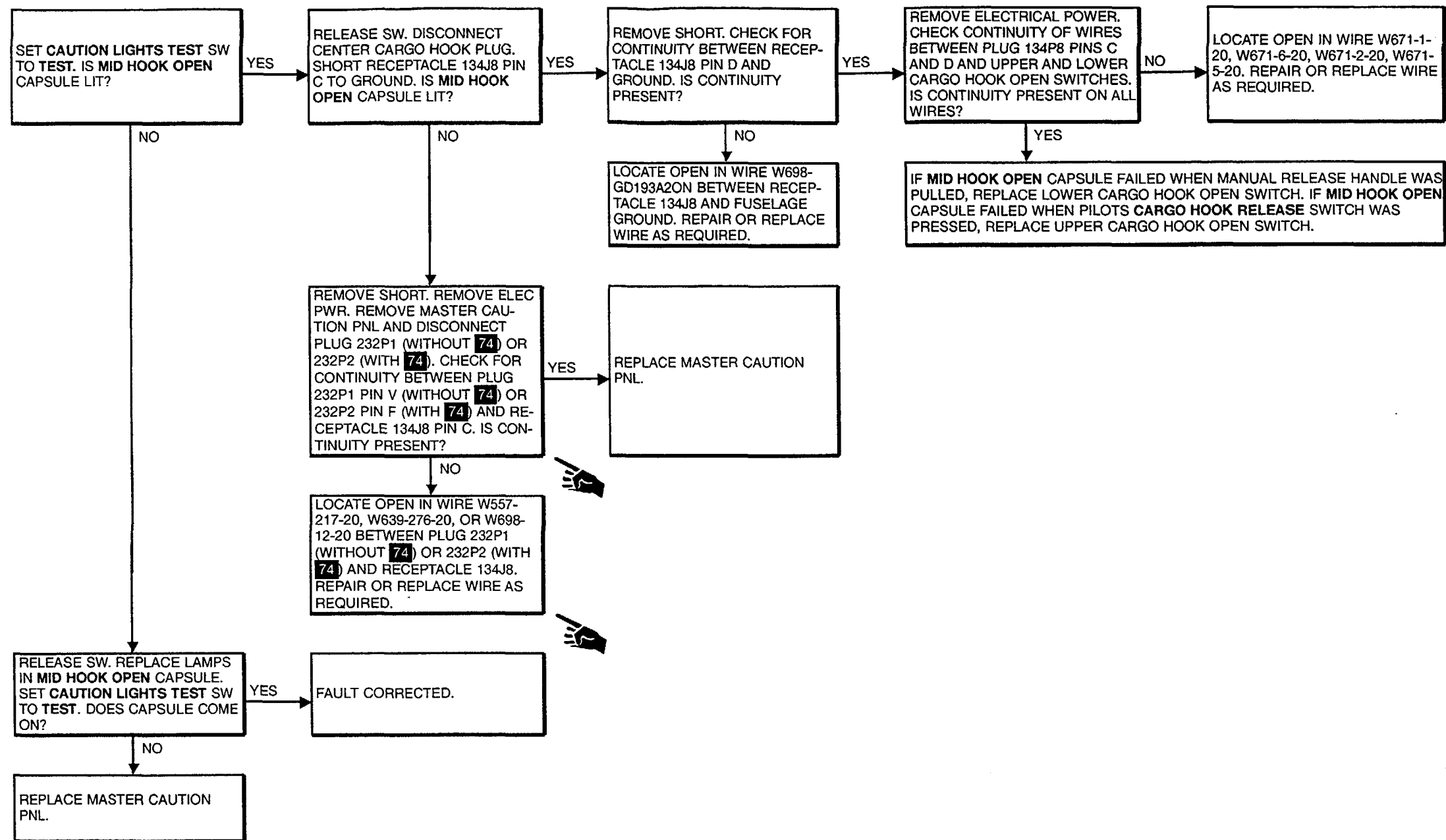

END OF TASK

Change 23 16-61

16-1.25 AFT CARGO HOOK DOES NOT OPEN

FAULT ISOLATION PROCEDURE

INITIAL SETUP

Applicable Configurations

All

Tools

Electrical Repairer's Tool Kit,
NSN 5180-00-323-4915
Multimeter

Materials

None

Personnel Required:

68F10 Aircraft Electrician
68F20 Aircraft Electrician

References

TM 55-1520-240-23

Equipment Condition:

TM 55-1520-240-23:
Battery Connected
Electrical Power On
Hydraulic Power Off

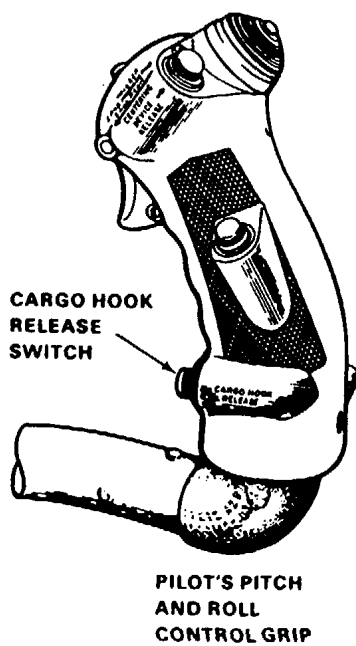
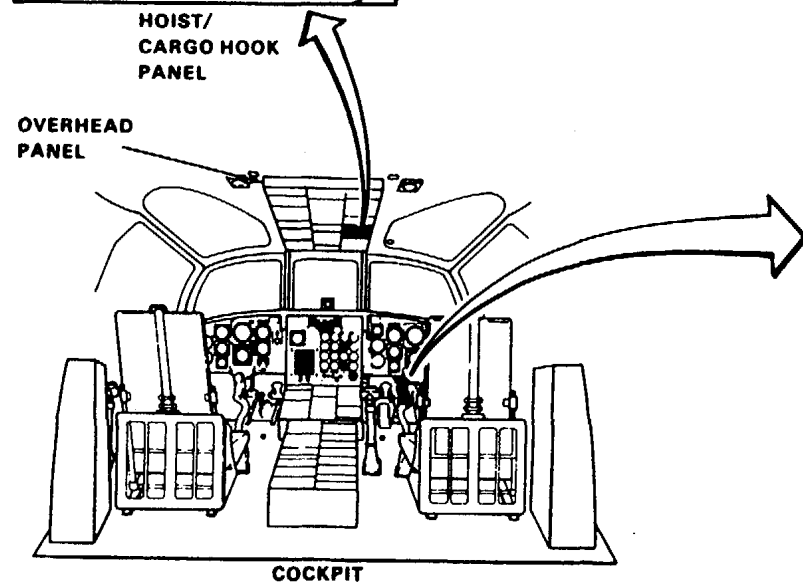
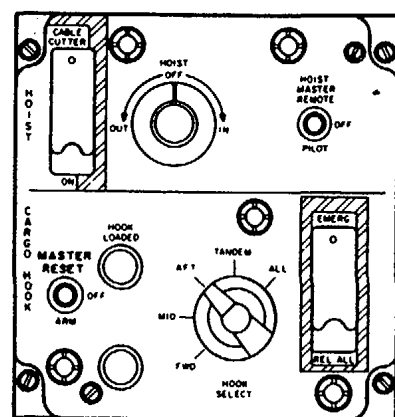
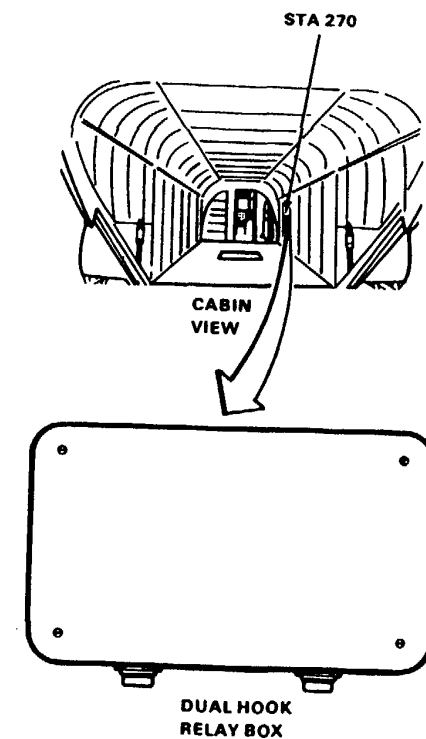
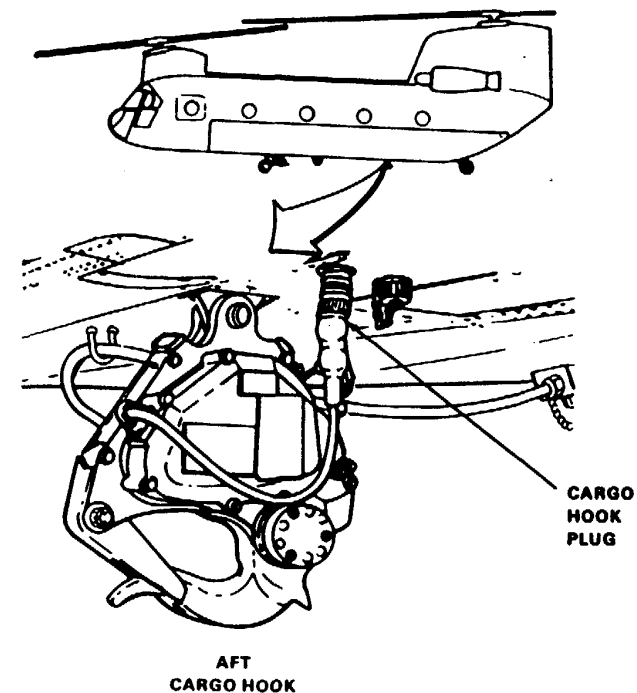

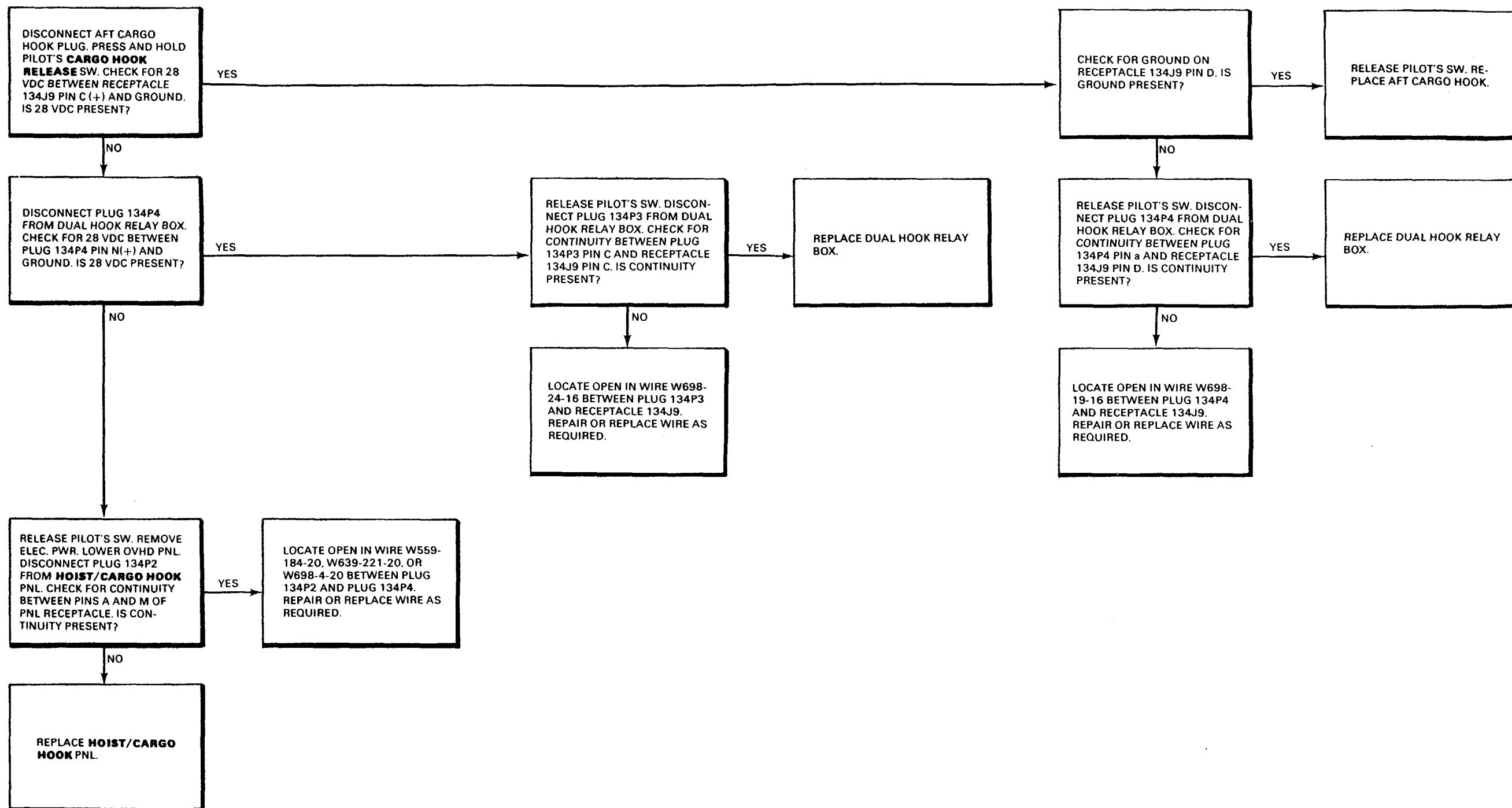

END OF TASK

16-1.26 AFT HOOK OPEN CAPSULE DOES NOT COME ON WHEN AFT CARGO HOOK OPENS

FAULT ISOLATION PROCEDURE

INITIAL SETUP

Applicable Configurations:
All

Tools:
Electrical Repairer's Tool Kit,
NSN 5180-00-323-4915
Multimeter

Materials:
None

Personnel Required:

Aircraft Electrician

References:

TM 55-1520-240-23

Equipment Condition:

TM 55-1520-240-23:
Battery Connected
Electrical Power On
Hydraulic Power Off

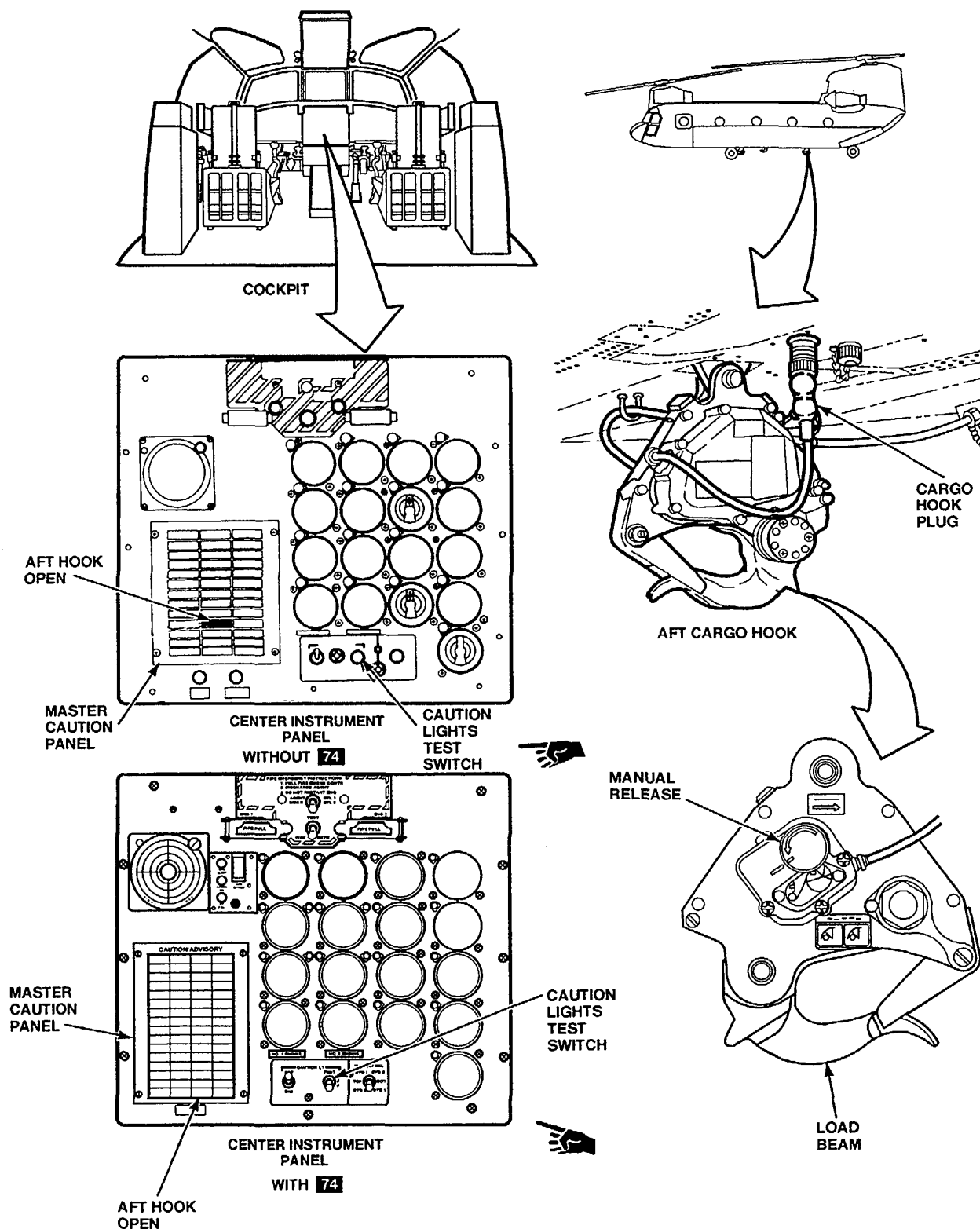
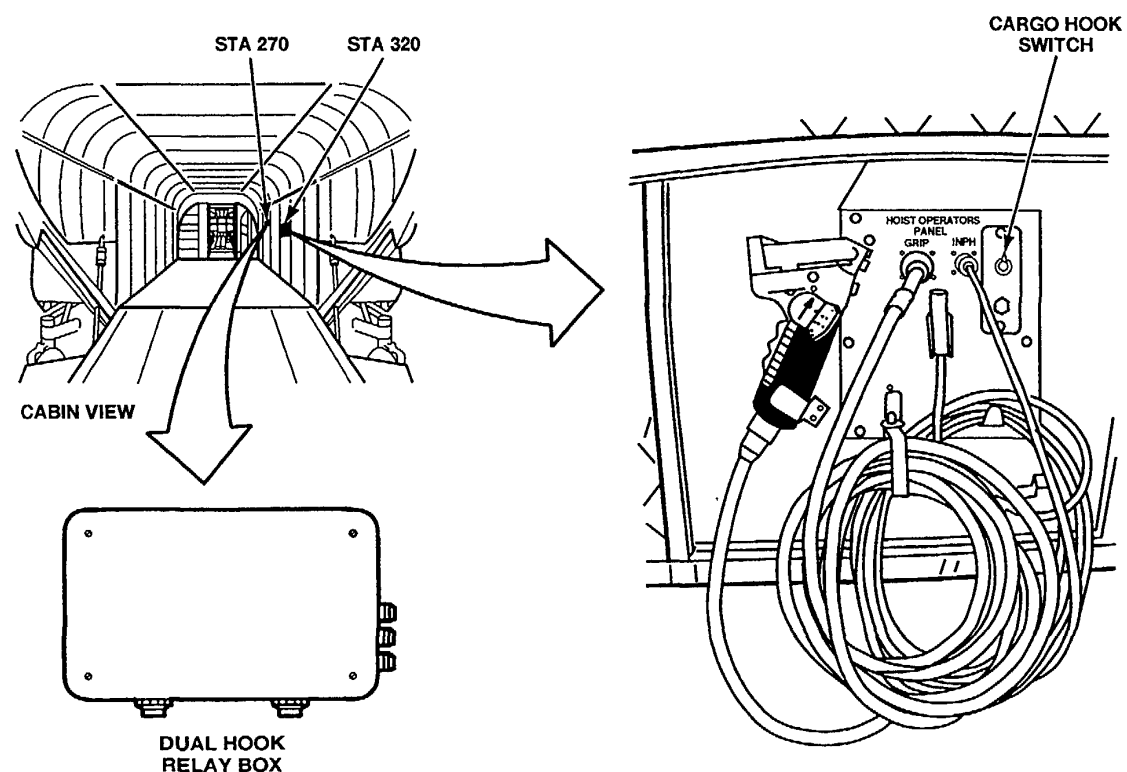

A65538

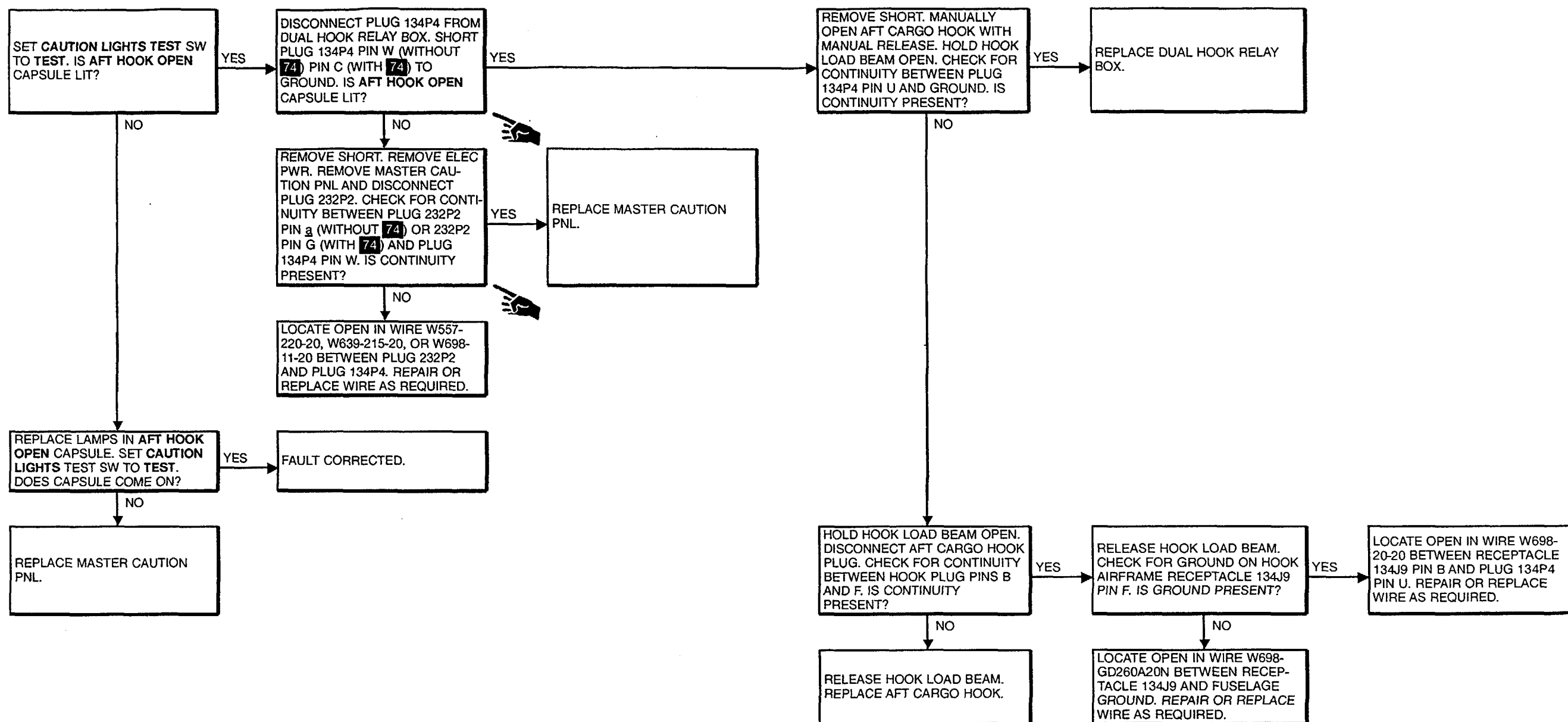

END OF TASK

Change 23 16-65

16-1.27 CARGO HOOK OR HOOKS DO NOT RELEASE WHEN EMERG SWITCH SET TO REL ALL

FAULT ISOLATION PROCEDURE

INITIAL SETUP

Applicable Configurations:
All

Tools:
Electrical Repairer's Tool Kit.
NSN 5180-00-323-4915
Multimeter

Materials:
None

Personnel Required:
68F20 Aircraft Electrician

References:
TM 55-1520-240-23

Equipment Condition:
TM 55-1520-240-23:
Battery Connected
Electrical Power On
Hydraulic Power Off

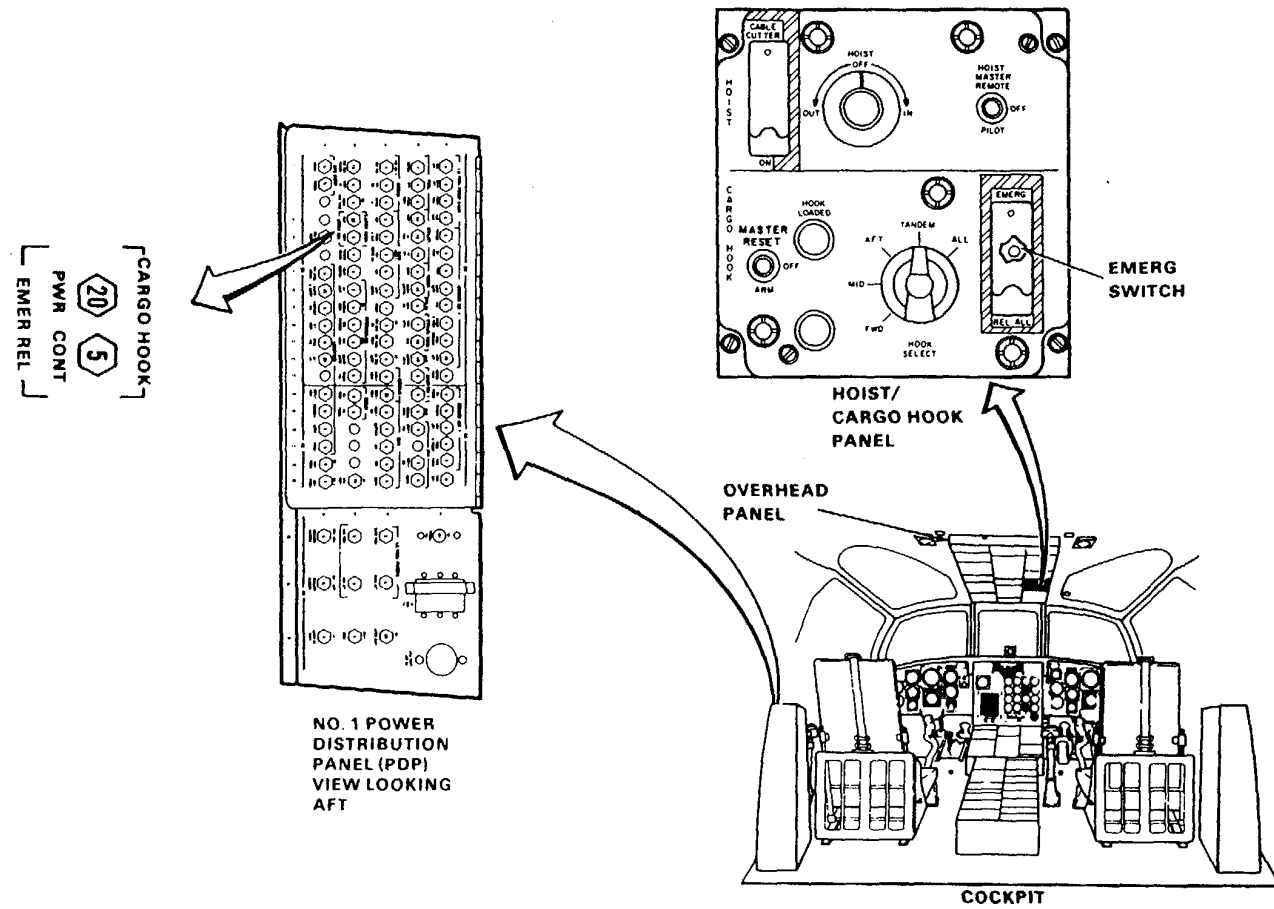
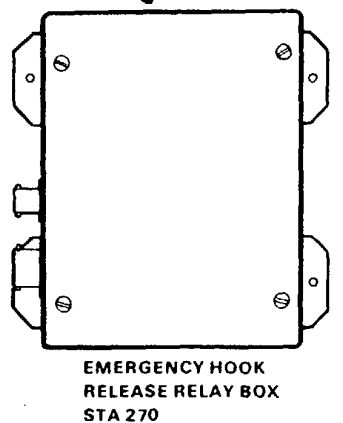
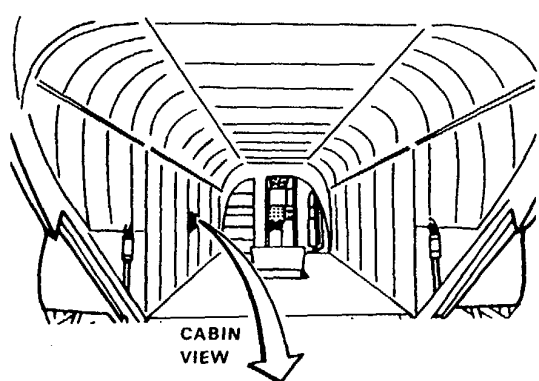
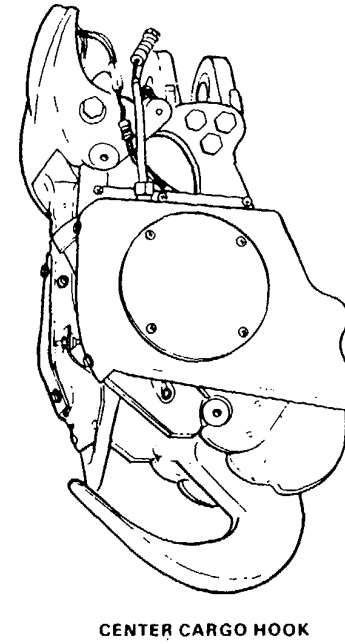
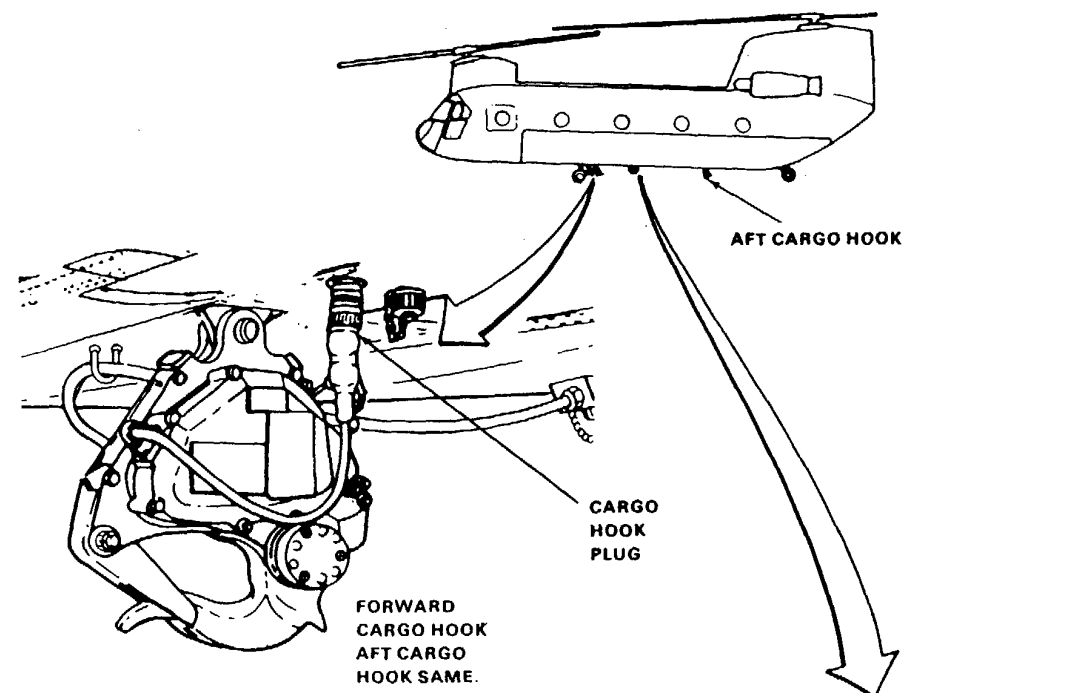

16-1.27 CARGO HOOK OR HOOKS DO NOT RELEASE WHEN EMERG SWITCH SET TO REL ALL (Continued)

16-1.27

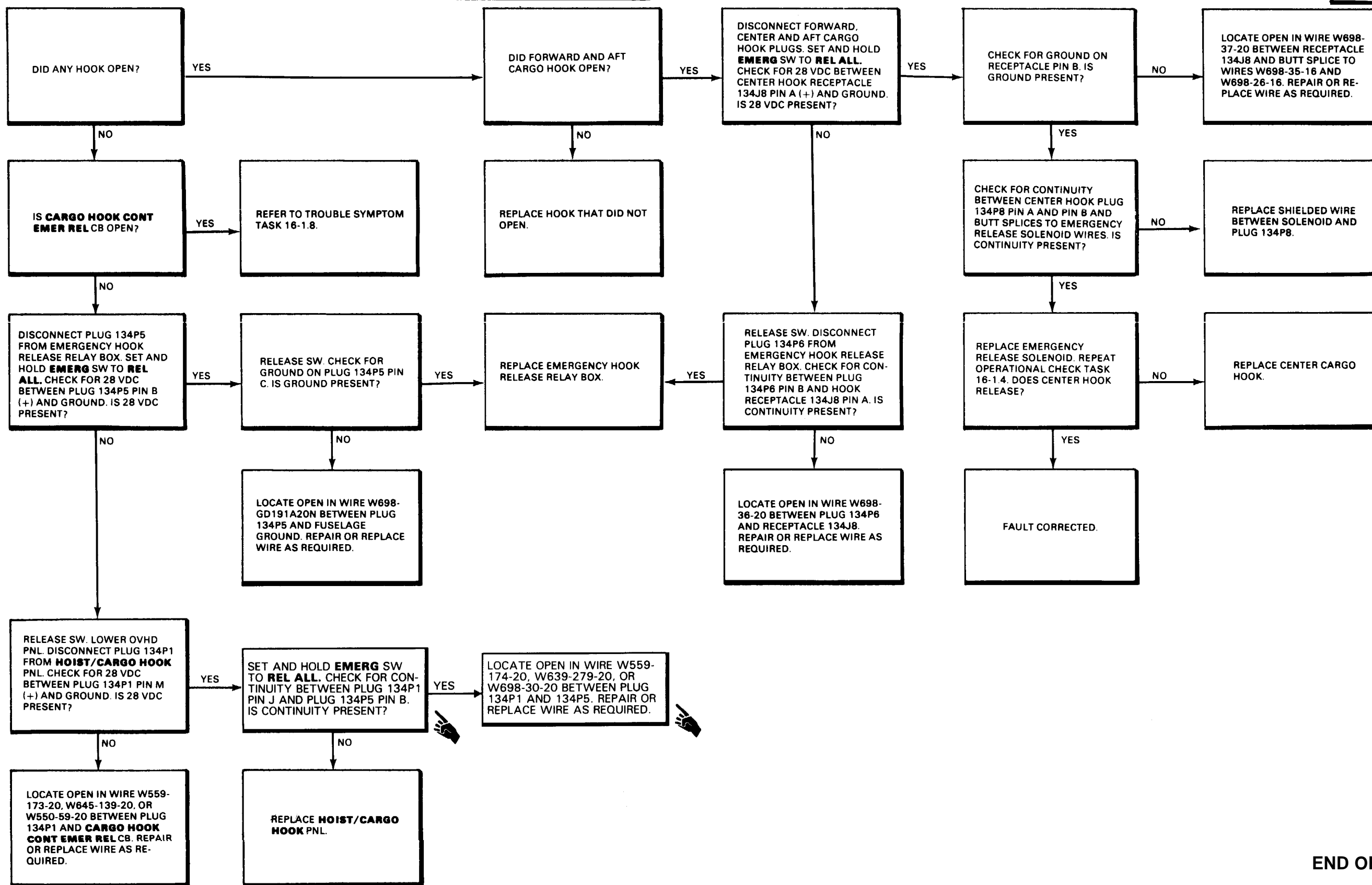

FAULT ISOLATION PROCEDURE

INITIAL SETUP

Applicable Configurations:

All

Tools:

- Electrical Repairer Tool Kit,
NSN 5180-00-323-4915
- Aircraft Mechanic Tool Kit,
NSN 5180-00-323-4692

Materials:

None

Personnel Required:

Medium Helicopter Repairer (2)

References:

TM 55-1520-240-23

Equipment Condition:

- TM 55-1520-240-23:
- Battery Disconnected
- Electrical Power Off
- Hydraulic Power Off

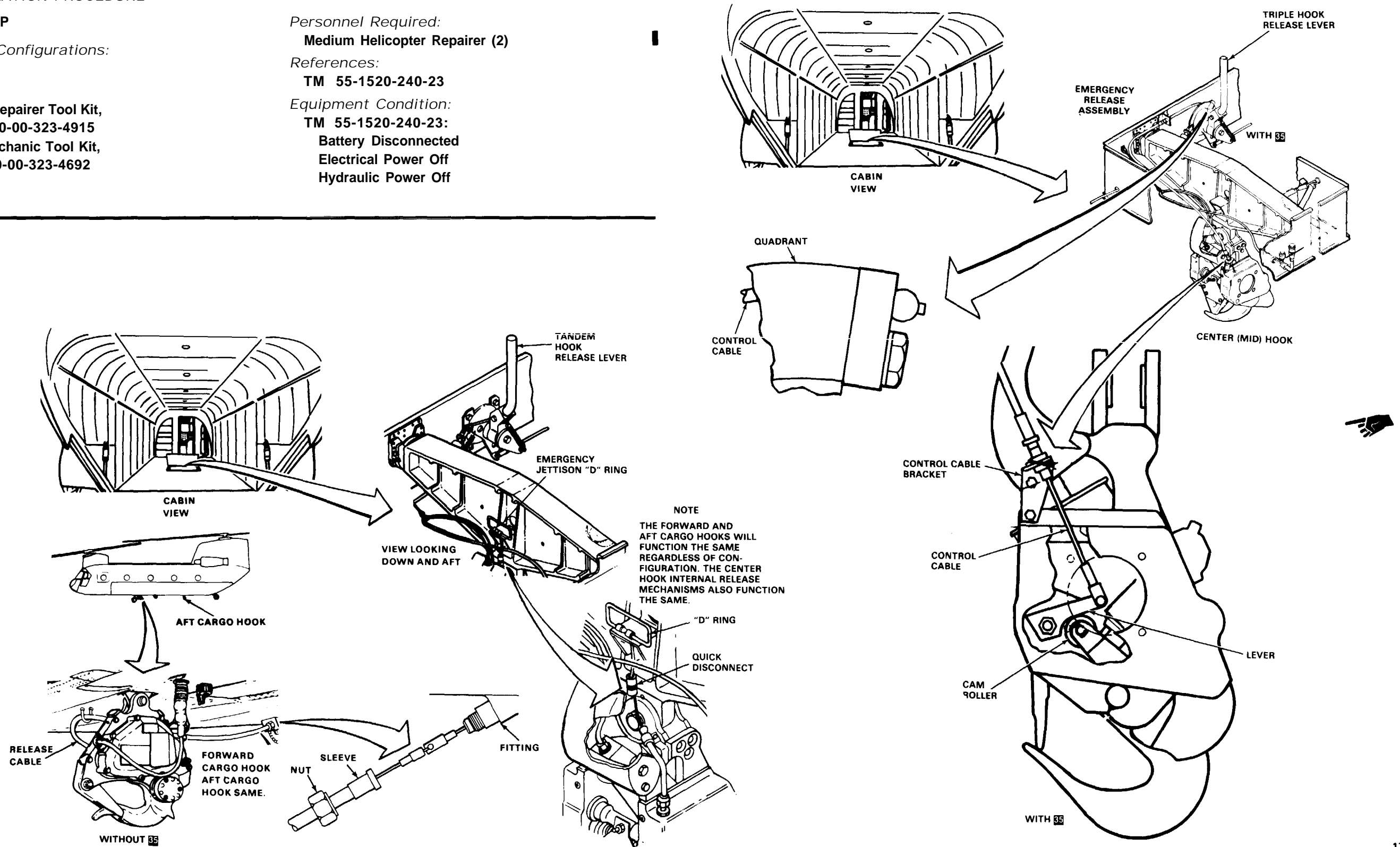

17327

16-1.29 FORWARD CENTER OR AFT CARGO HOOK DOES NOT OPEN WHEN TRIPLE/TANDEM HOOK OR CENTER HOOK RELEASE LEVER IS PULLED (Continued)

FORWARD OR AFT CARGO HOOK DOES NOT OPEN

CENTER CARGO HOOK DOES NOT OPEN

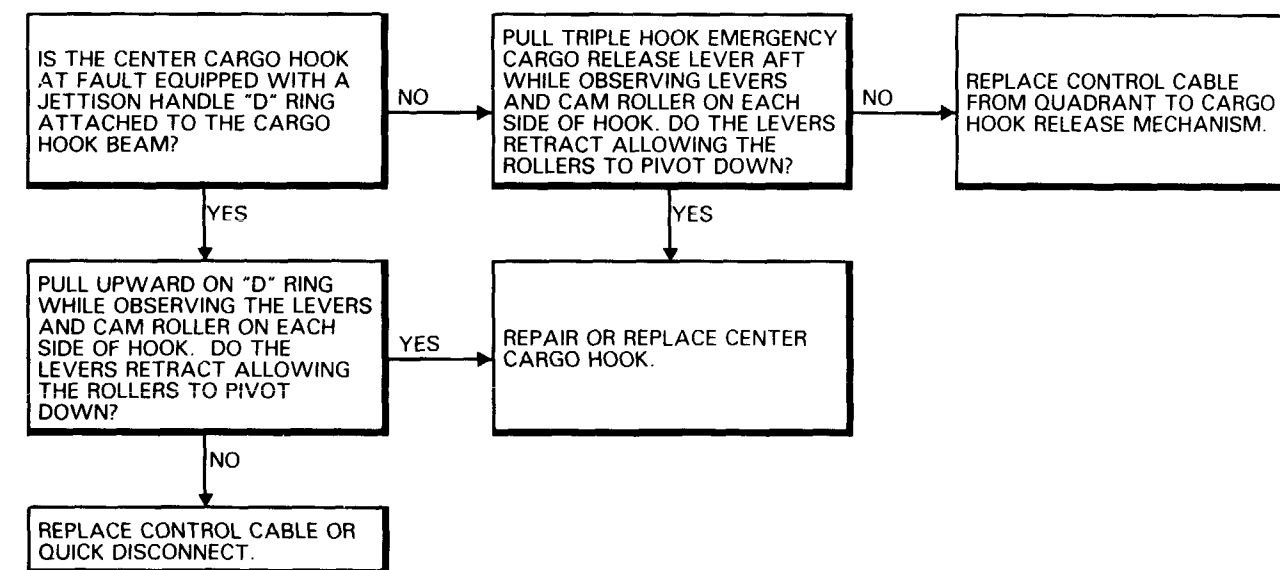
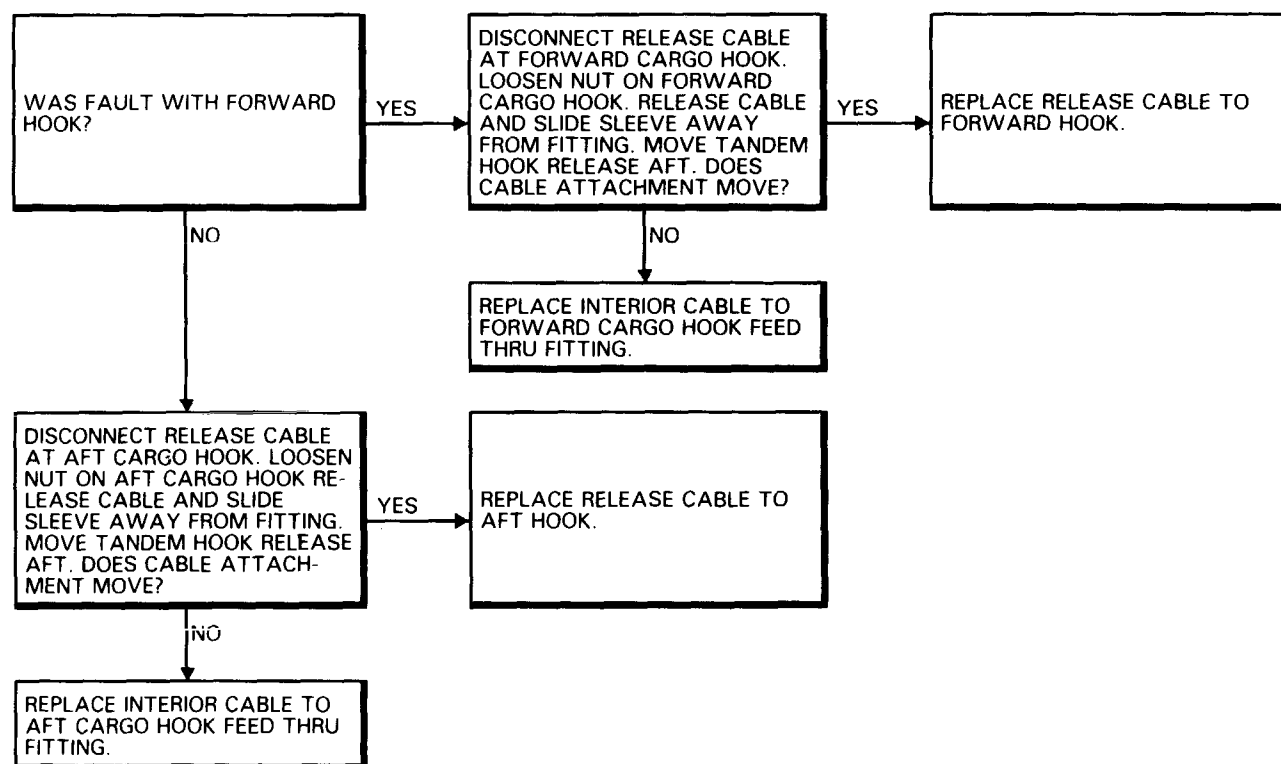

16-1.30 HOOK LOADED LIGHT DOES NOT COME ON WHEN FORWARD OR AFT CARGO HOOK IS LOADED (Continued)

16-1.30

FWD HOOK LOADED LIGHT DOES NOT COME ON WHEN FORWARD CARGO HOOK IS LOADED

AFT HOOK LOADED LIGHT DOES NOT COME ON WHEN AFT CARGO HOOK IS LOADED

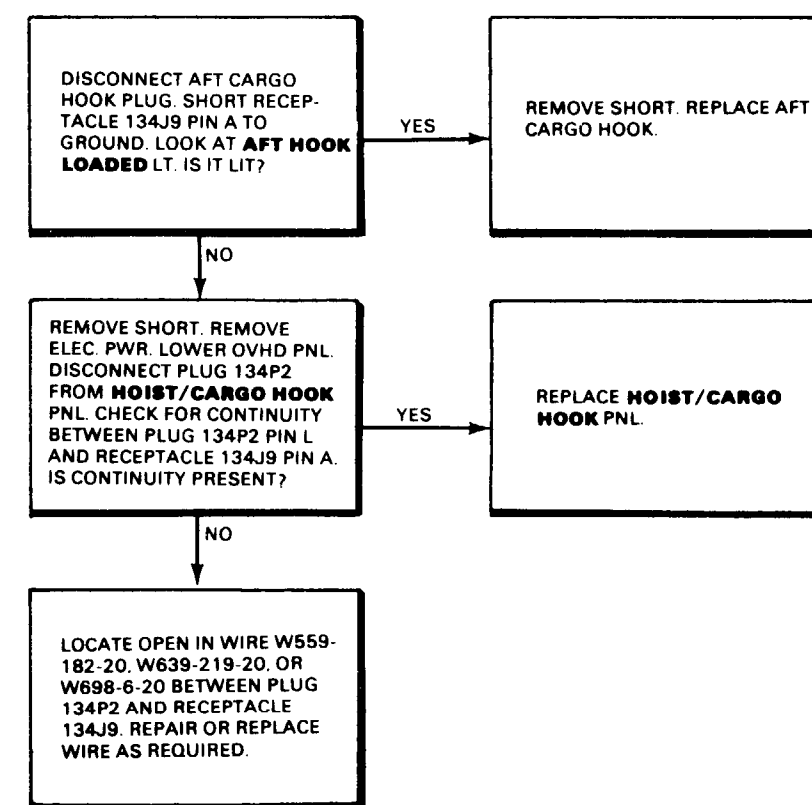
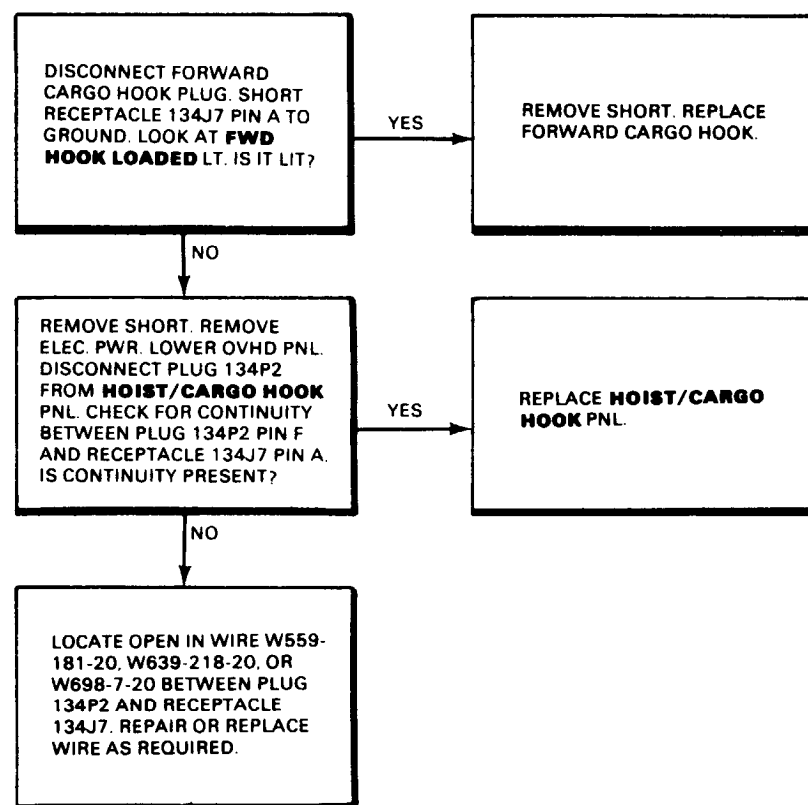

END OF TASK

16-2 FLARE DISPENSER SYSTEM

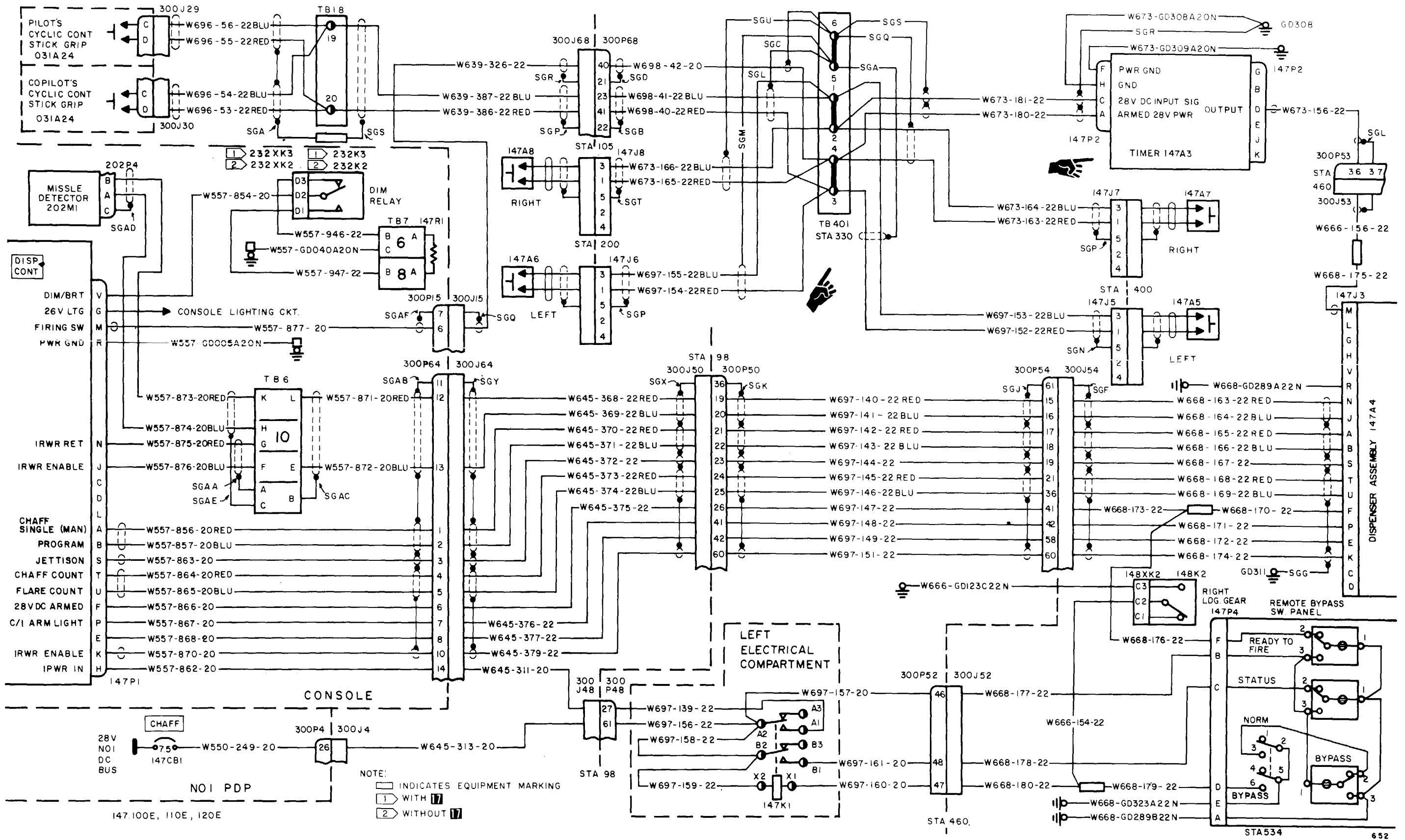

INITIAL SETUP

Applicable Configurations:

All

Tools:

Electronic Equipment Tool Kit,
NSN 5180-00-064-5178

Materials:

Cloth (E 120)

Personnel Required:

Avionics Mechanic

References:

TM 55-1520-240-10

TM 55-1520-240-23

Equipment Condition:

TM 55-1520-240-10:

Flare Dispenser Assembly Safety Pin Installed

TM 55-1520-240-23:

Battery Connected

Electrical Power Off

Hydraulic Power Off

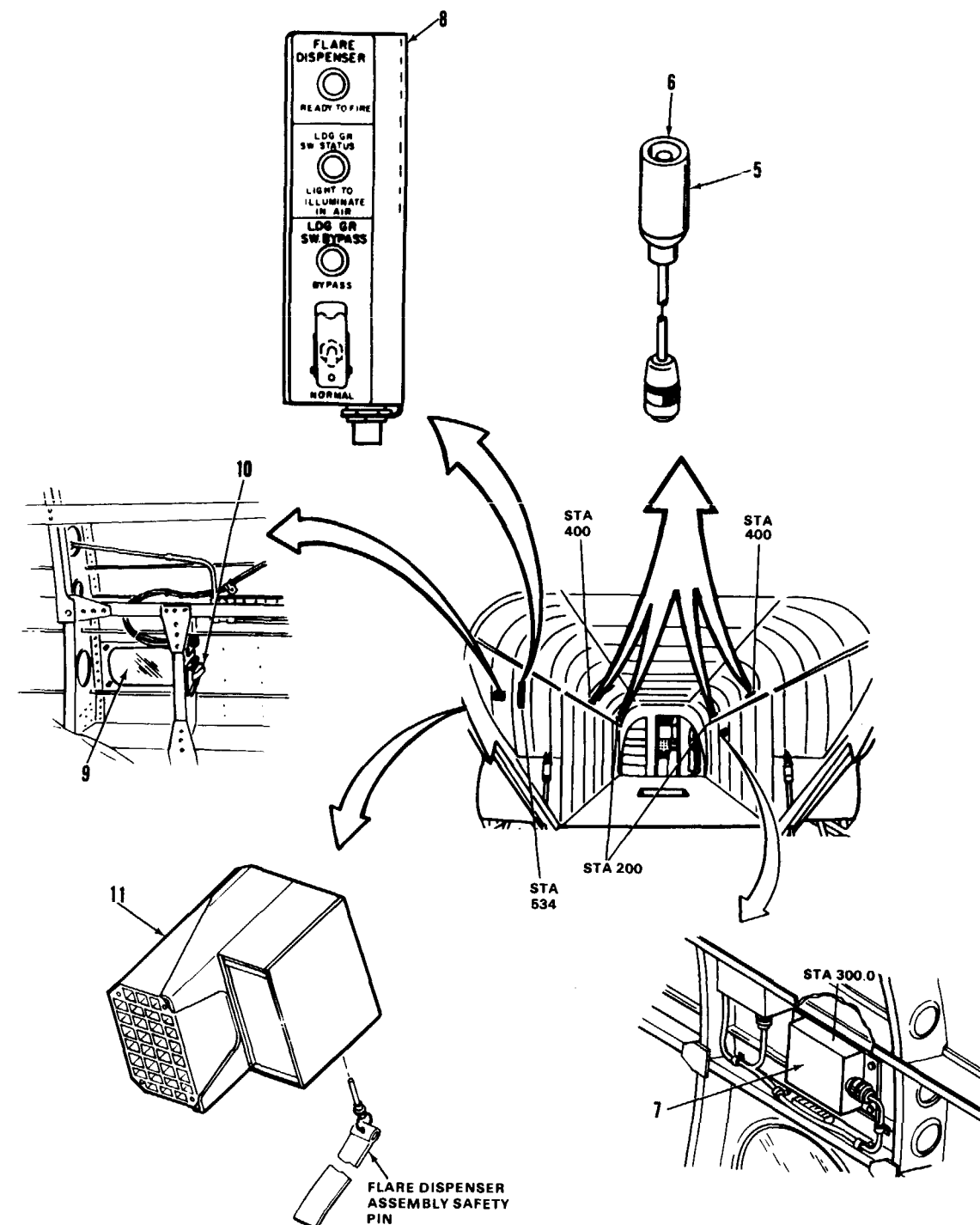
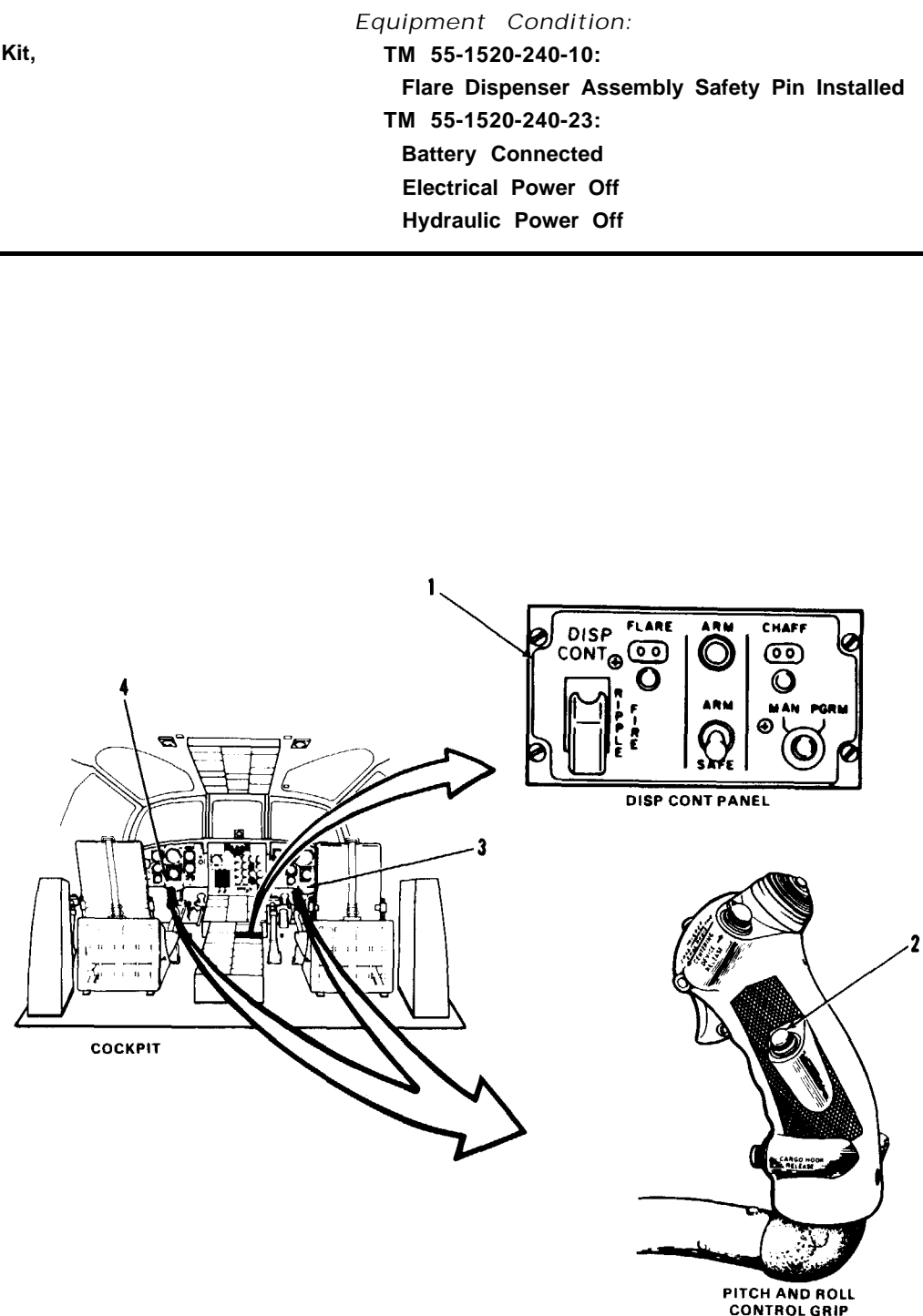

90X54

D145-11440-SPA

16-2.2 FLARE DISPENSER SYSTEM VISUAL CHECK (Continued)

16-2.2

TASK	RESULT
1. Check DISP CONT panel (1).	If any switch, counter, or light on panel (1) is damaged, replace panel.
2. Check flare DISP switch (2) on pilot's and copilot's pitch and roll control grips (3 and 4).	If either switch (2) is damaged, replace grip (3 or 4).
3. Check four cable assemblies (5).	If any cable assembly (5) is damaged, repair or replace it as required. If any switch (6) in cable assembly (5) is damaged replace cable assembly.
4. Check timer (7).	If timer (7) is loose or damaged tighten or replace it as required. If connector to timer is loose or damaged, tighten or replace it as required. If wiring to connector is damaged, repair or replace it as required.
5. Check dispenser status panel (8).	If any light or switch on panel (8) is damaged, replace it. If connector to panel is loose or damaged, tighten or replace it as required. If wiring to connector is damaged repair or replace it as required.
6. Check flare dispenser viewing window (9).	If window (9) is clouded or broken, clean or replace it as required.
7. Check flare dispenser wiring and electrical plug and receptacle (10).	If plug or receptacle (10) is loose or damaged, tighten or replace it as required. If wiring to plug or receptacle is damaged, repair or replace it as required.
8. Check flare dispenser assembly (11).	If dispenser is loose or damaged, tighten or replace it as required.

FOLLOW-ON MAINTENANCE:

None

END OF TASK

16-79

INITIAL SETUP

Applicable Configurations:

All

Tools:

Electronic Equipment Tool Kit,
NSN 5180-00-064-5178

Materials:

None

Personnel Required:

Avionics Mechanic

References:

TM 55-1520-240-23

Equipment Condition:

TM 55-1520-240-23:

Flare Dispenser Assembly Removed

Battery Connected

Electrical Power On

Hydraulic Power Off

Visual Check of Flare Dispenser System Performed
(Task 16-2.2)

General Safety Instructions:

WARNING

Do not perform test with flare dispenser assembly installed. System could fire resulting in damage injury or death.

WARNING

Keep personnel clear of flight controls.

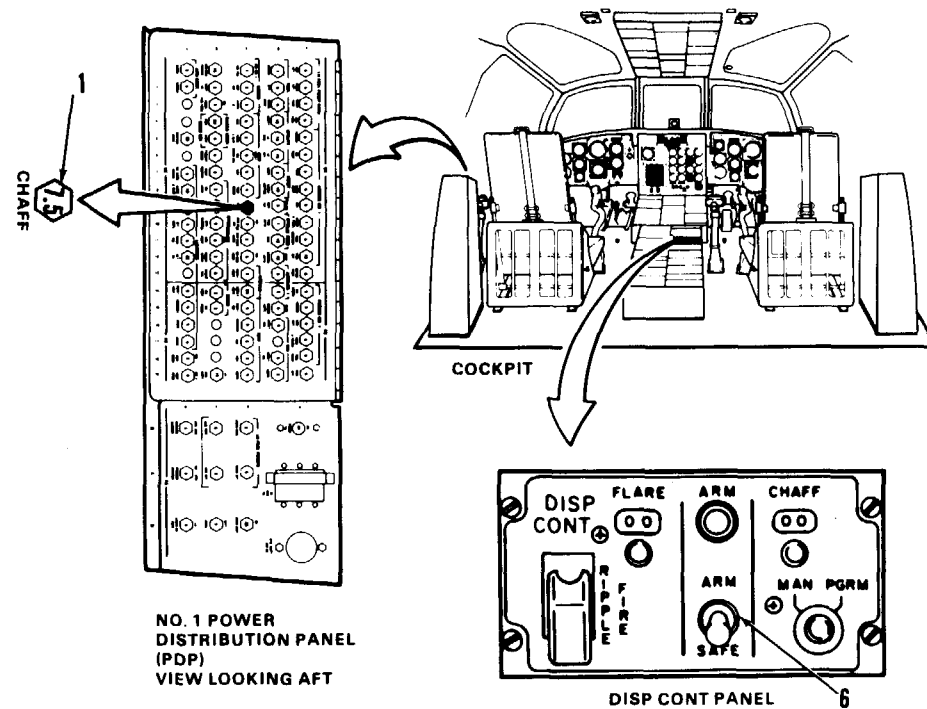
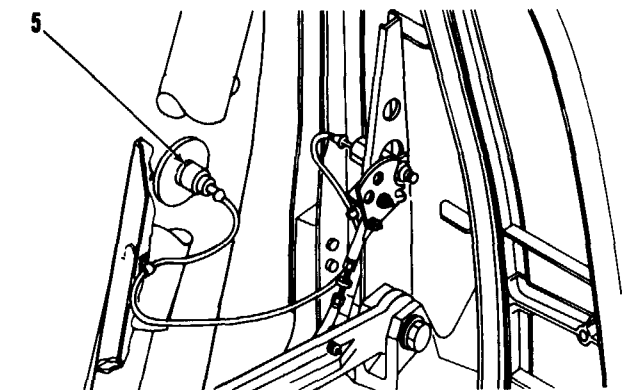
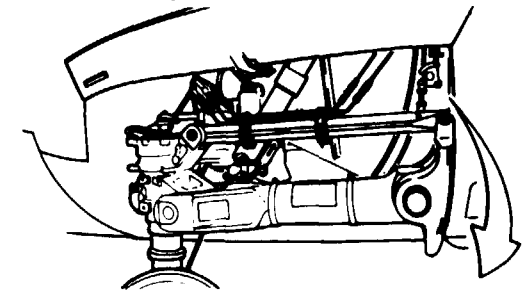
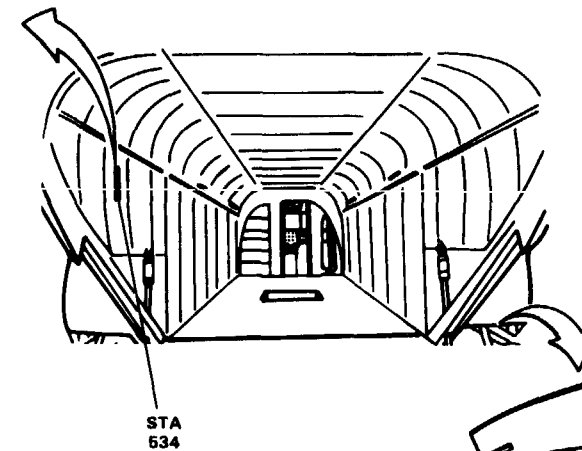
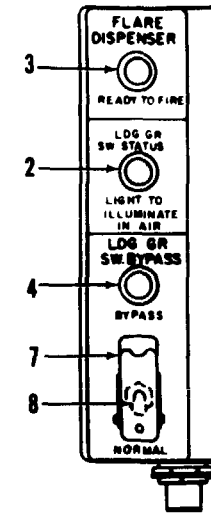

NO. 1 POWER DISTRIBUTION PANEL (PDP) VIEW LOOKING AFT

DISP CONT PANEL

90X54

0145-11441-SPA

16-2.3 FLARE DISPENSER SYSTEM OPERATIONAL CHECK (Continued)

16-2.3

TASK	RESULT
1. Check that CHAFF circuit breaker (1) is closed.	If circuit breaker (1) is open, close it. If it opens again, go to task 16-2.4.
2. Check that LDG GR SW STATUS light (2) is out.	If light (2) is on, go to task 16-2.5.
3. Press and release LDG GR SW STATUS, READY TO FIRE and LDG GR SW BYPASS lights (2, 3, and 4).	Each light (2, 3, and 4) shall momentarily come on. If any light does not come on, go to task 16-2.6.
4. Disconnect right landing gear proximity switch plug (5).	LDG GR SW STATUS light (2) shall come on. If it does not come on, go to task 16-2.7.
5. Set DISP CONT panel ARM SAFE switch (6) to ARM.	READY TO FIRE light (3) shall come on. If light does not come on, go to task 16-2.8
6. Connect right landing gear proximity switch plug. (5).	LDG GR SW STATUS and READY TO FIRE light (2 and 3) shall go out.
7. Lift switchguard (7) and set LDG GR SW BYPASS switch (8) to BYPASS.	LDG GR SW STATUS, READY TO FIRE, and LDG GR SW BYPASS LIGHTS (2,3 and 4) shall come on. If they do not, go to task 16-2,10.
8. Set DISP CONT panel ARM SAFE switch (6) to SAFE.	READY TO FIRE light (3) shall go out.
9. Set LDG GR SW BYPASS switch (8) to NORMAL and close switchguard (7).	LDG GR SW STATUS light (2) and LDG GR SW BYPASS light (4) shall go out,
10. Perform functional test of flare dispenser system, Refer to TM 55-1520-240-23.	

NOTE

If a problem occurs during functional test of flare dispenser system, refer to table 16-2.1 to locate trouble symptom task number.

TABLE 16-2.1

TROUBLE SYMPTOM	TASK NUMBER
FLARE COUNTER SEQUENCES FROM 30 TO 00 WHEN DISP CONT PANEL ARM SAFE SWITCH SET TO ARM.	16-2.11
ARM LIGHT DOES NOT COME ON WHEN ARM SAFE SWITCH SET TO ARM.	16-2.12
FLARE COUNTER OR TEST SET LIGHTS 00 NOT CHANGE WHEN PILOT OR COPILOT FLARE DISP SWITCH PRESSED AND RELEASED.	16-2.13
FLARE COUNTER OR TEST SET LIGHTS DO NOT CHANGE WHEN A CABIN FIRING SWITCH PRESSED AND RELEASED,	16-2.14
FLARE COUNTER DOES NOT INDICATE 00 WHEN RIPPLE FIRE SWITCH IS HELD UP.	16-2.15

FOLLOW-ON MAINTENANCE:

- TM 55-1520-240-23:
- Remove Electrical Power
- Disconnect Battery
- Install Flare Dispensanser Assembly

END OF TASK

FAULT ISOLATION PROCEDURE

INITIAL SETUP

Applicable Configurations:

All

Tools:

Electronic Equipment Tool Kit,
NSN 5180-00-064-5178

Materials:

None

Personnel Required:

Avionics Mechanic

References:

TM 55-1520-240-23

Equipment Condition:

TM 55-1520-240-23:

Battery Disconnected

Electrical Power Off

Hydraulic Power Off

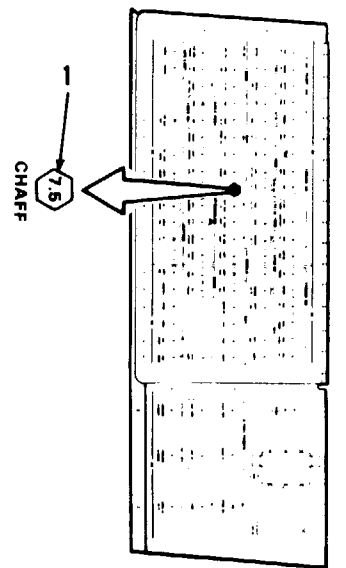

NO. 1 POWER DISTRIBUTION PANEL (PDP) VIEW LOOKING AFT

90X54

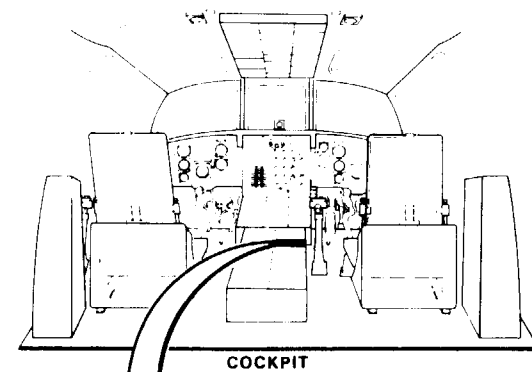

COCKPIT

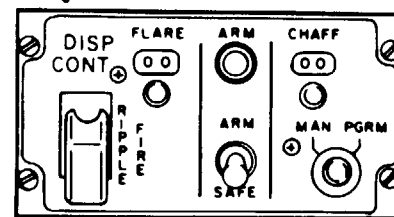

DISP CONT PANEL

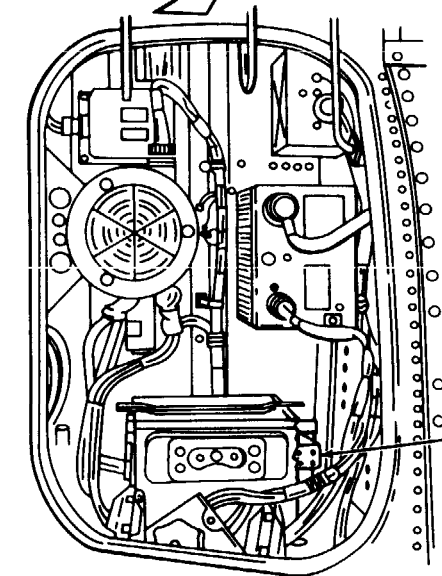

LEFT ELECTRICAL COMPARTMENT SHOWN WITH DOOR OFF FOR CLARITY

REMOTE BYPASS SW PANEL

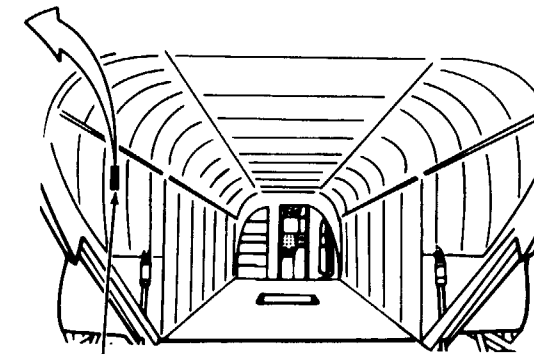
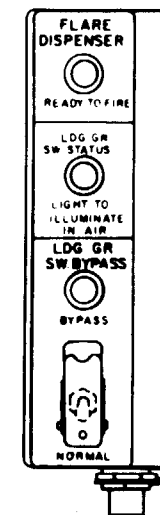

STA 534

D145-12053-SPA

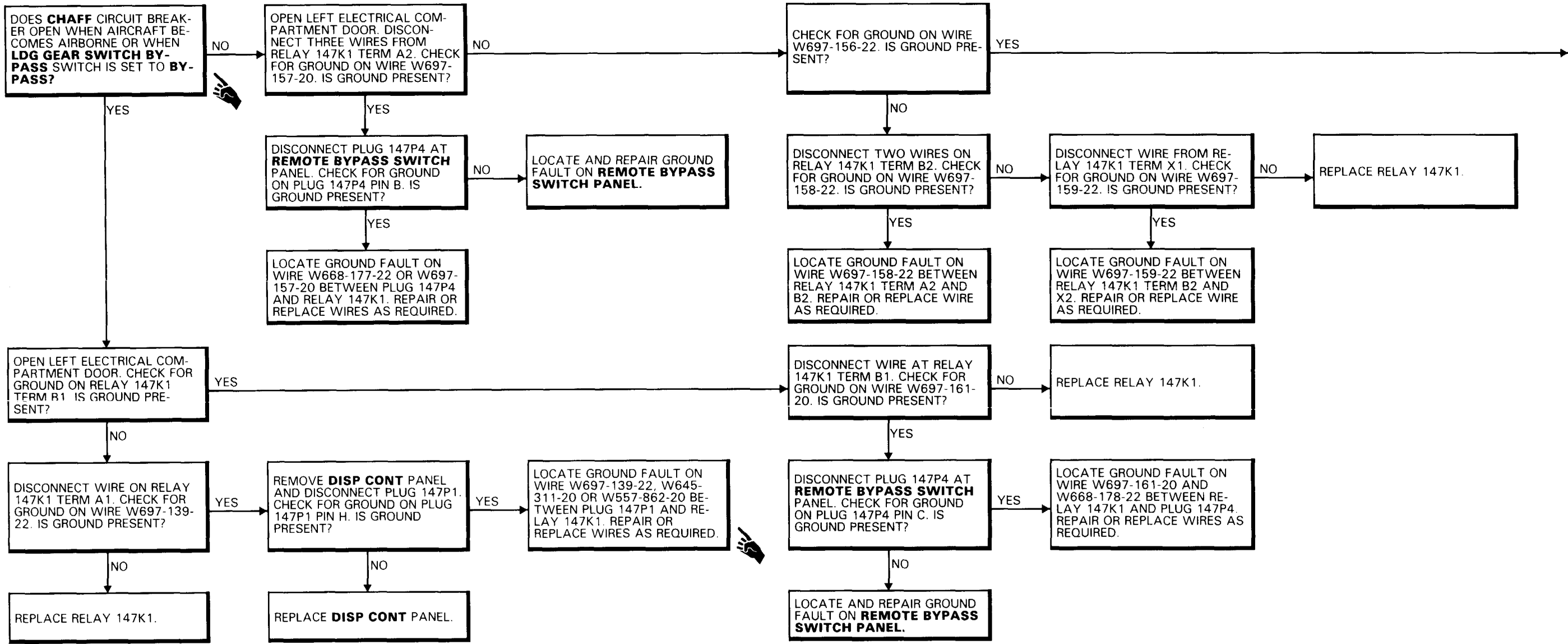

16-2.4 CHAFF CIRCUIT BREAKER WILL NOT STAY CLOSED
(Continued)

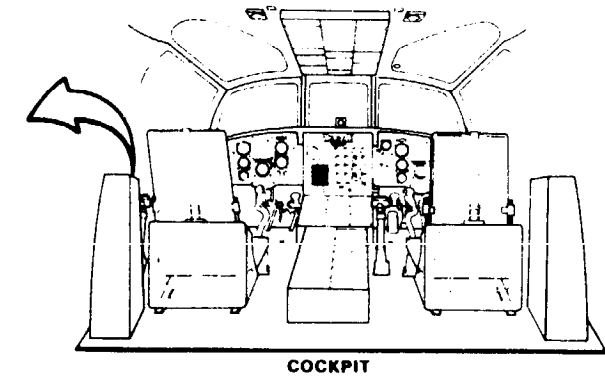
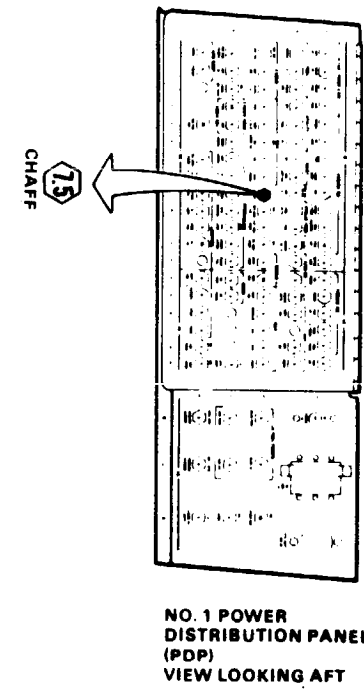
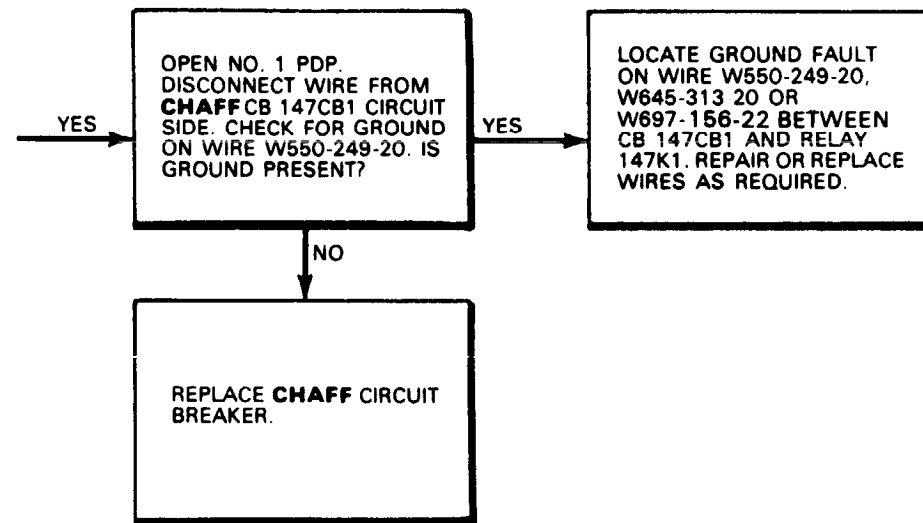

45X54

0145-12054-SPA

FAULT ISOLATION PROCEDURE

INITIAL SETUP

Applicable Configurations:

All

Tools:

Electronic Equipment Tool Kit,
NSN 5180-00-064-5178

Materials:

None

Personnel Required:

Avionics Mechanic (2)

References:

TM 55-1520-240-23

Equipment Condition:

TM 55-1520-240-23:

Battery Connected
Electrical Power On
Hydraulic Power Off

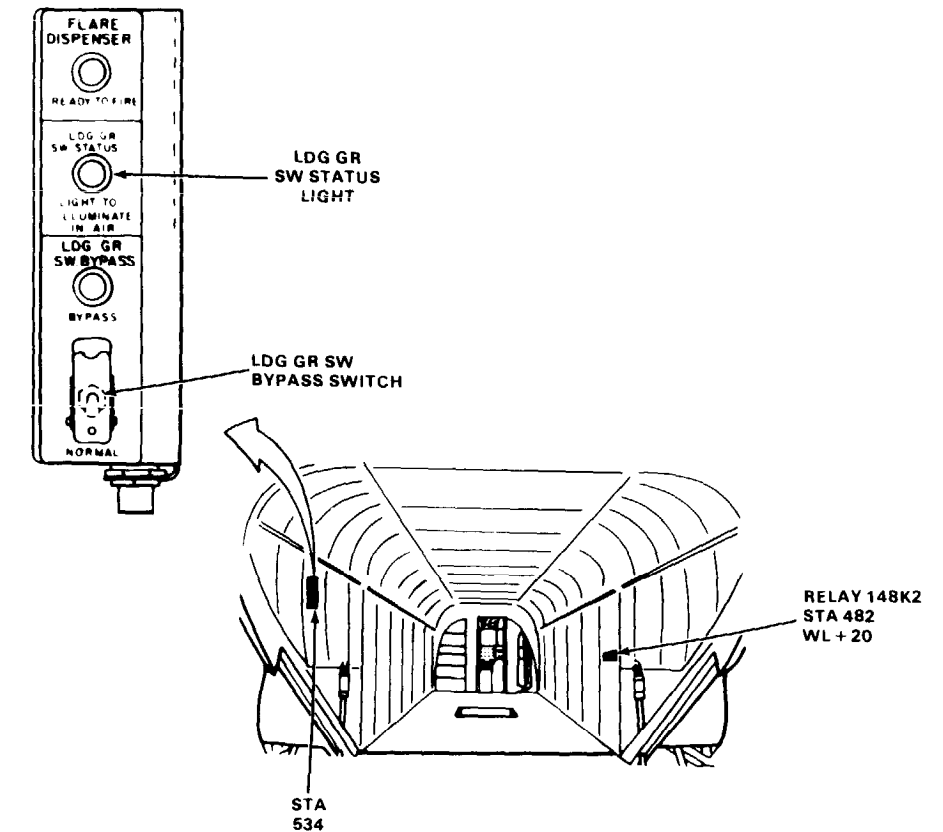
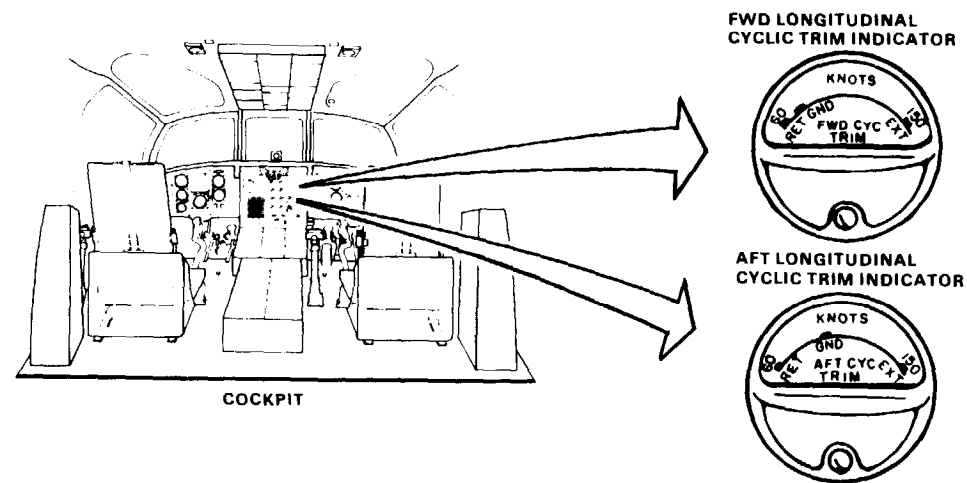

90X54

16-2.5 LANDING GEAR SWITCH STATUS LIGHT IS ON (Continued)

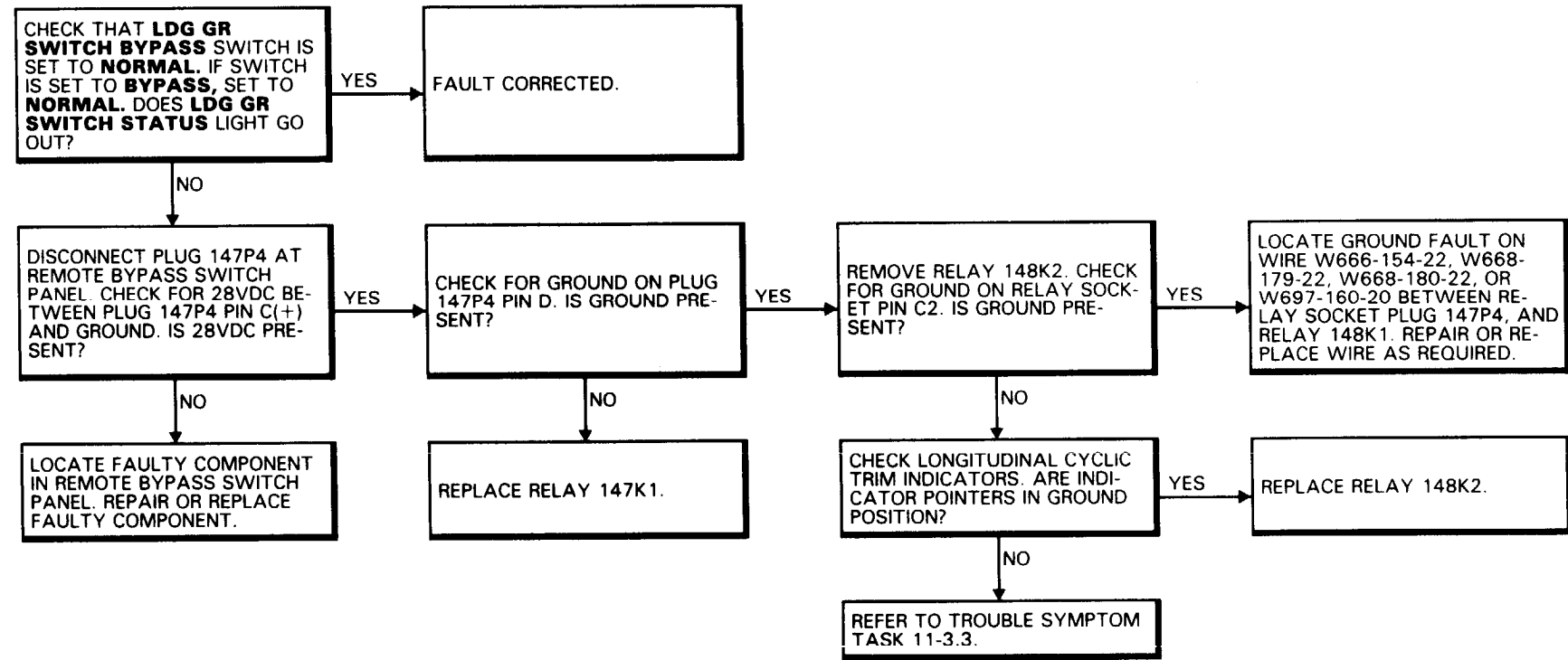

FAULT ISOLATION PROCEDURE

INITIAL SETUP

Applicable Configurations:

All

Tools:

Electronic Equipment Tool Kit,
NSN 5180-00-064-5178

Materials:

None

Personnel Required:

Avionics Mechanic

References:

TM 55-1520-240-23

Equipment Condition:

TM 55-1520-240-23:

Battery Connected
Electrical Power On
Hydraulic Power Off

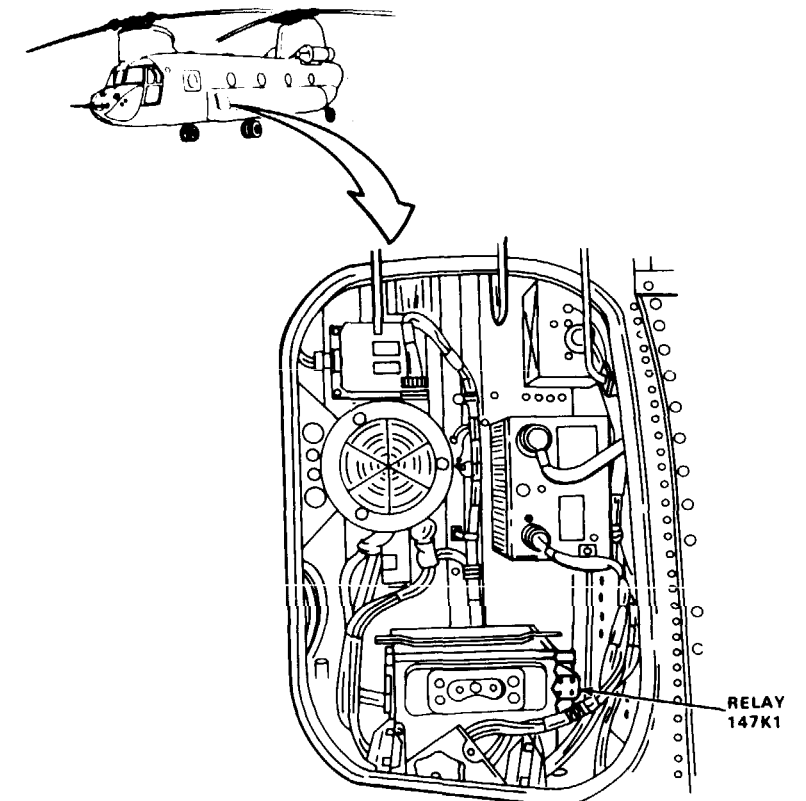

LEFT ELECTRICAL COMPARTMENT
SHOWN WITH DOOR OFF FOR CLARITY

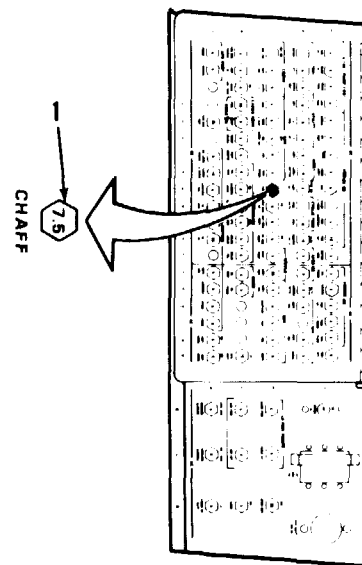

NO. 1 POWER
DISTRIBUTION
PANEL (PDP)
VIEW LOOKING AFT

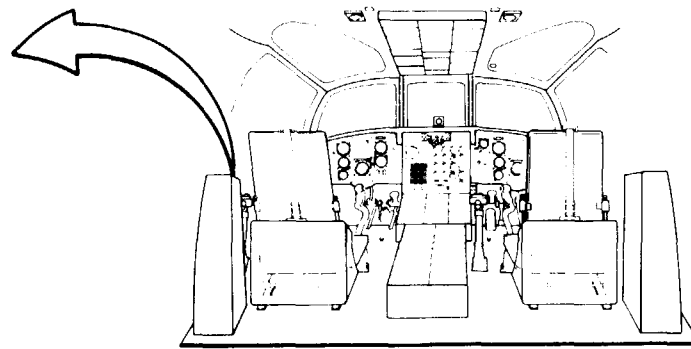

COCKPIT

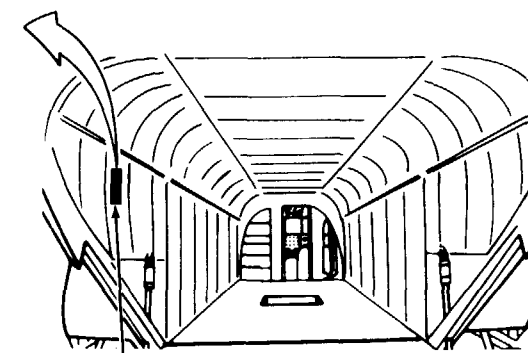
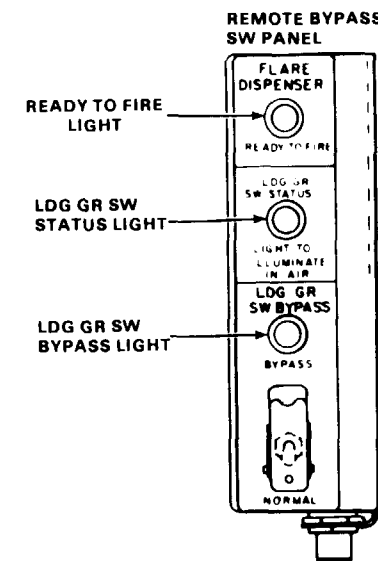

STA
534

90X54

D145-12056-SPA

16-2.6 LDG GR SW STATUS, READY TO FIRE, OR LDG GR SW BYPASS LIGHTS DO NOT COME ON WHEN PRESSED (Continued)

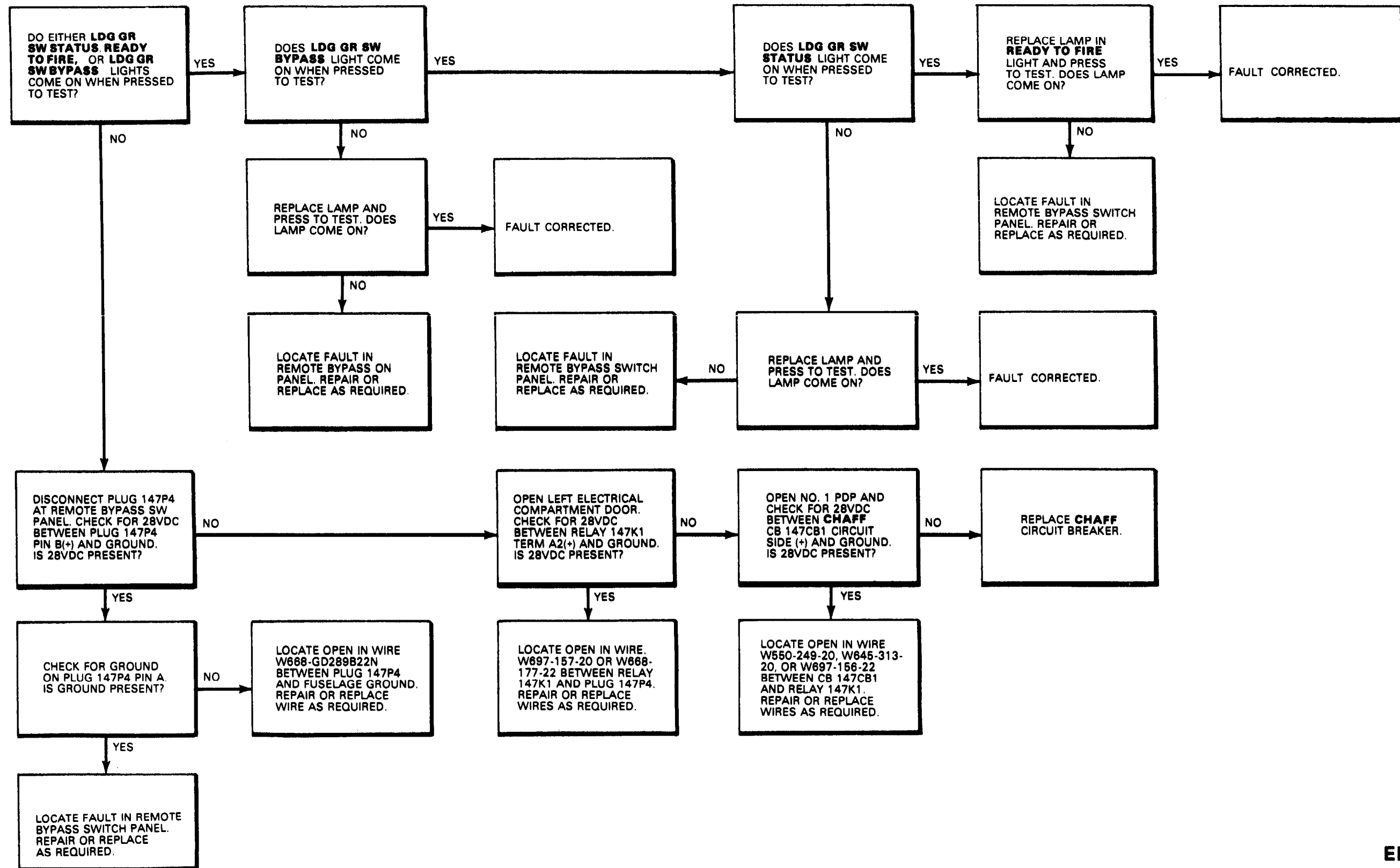

END OF TASK

FAULT ISOLATION PROCEDURE

INITIAL SETUP

Applicable Configurations:

All

Tools:

Electronic Equipment Tool Kit,
NSN 5180-00-064-5178

Materials:

None

Personnel Required:

Avionics Mechanic (2)

References:

TM 55-1520-240-23

Equipment Condition:

TM 55-1520-240-23:

- Battery Connected
- Electrical Power On
- Hydraulic Power Off
- Right Landing Gear Proximity Switch Plug Disconnected

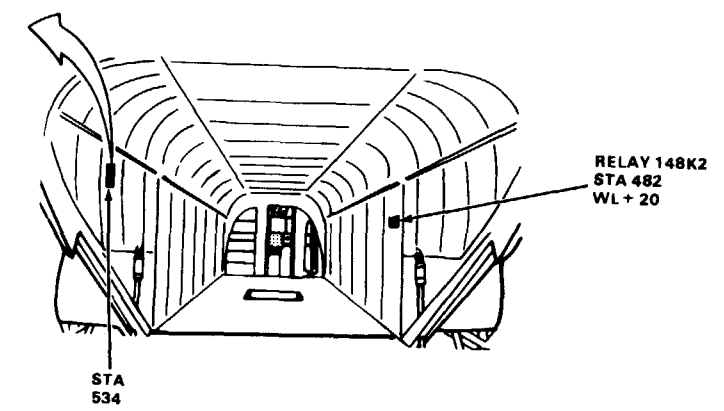
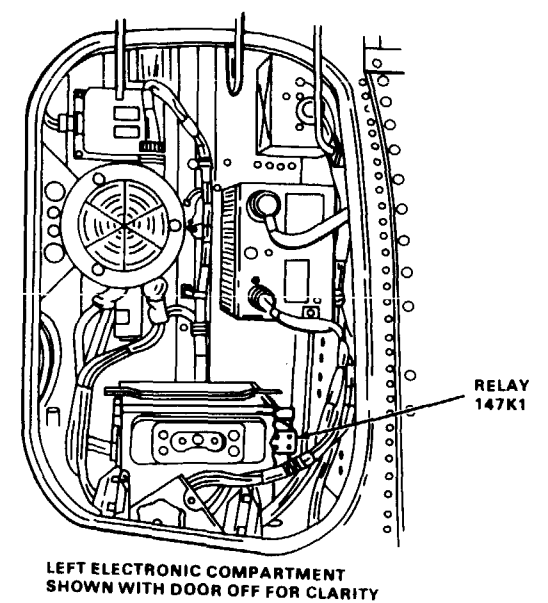
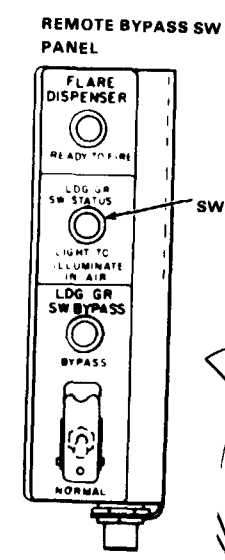
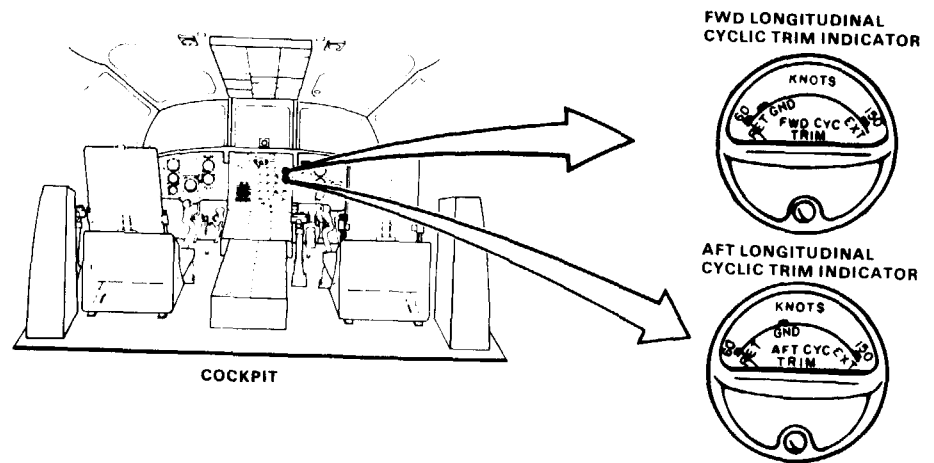
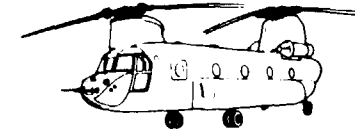

90X54

D145-12057-SPA

16-2.7 LDG GR SW STATUS LIGHT DOES NOT COME ON
(Continued)

16-2.7

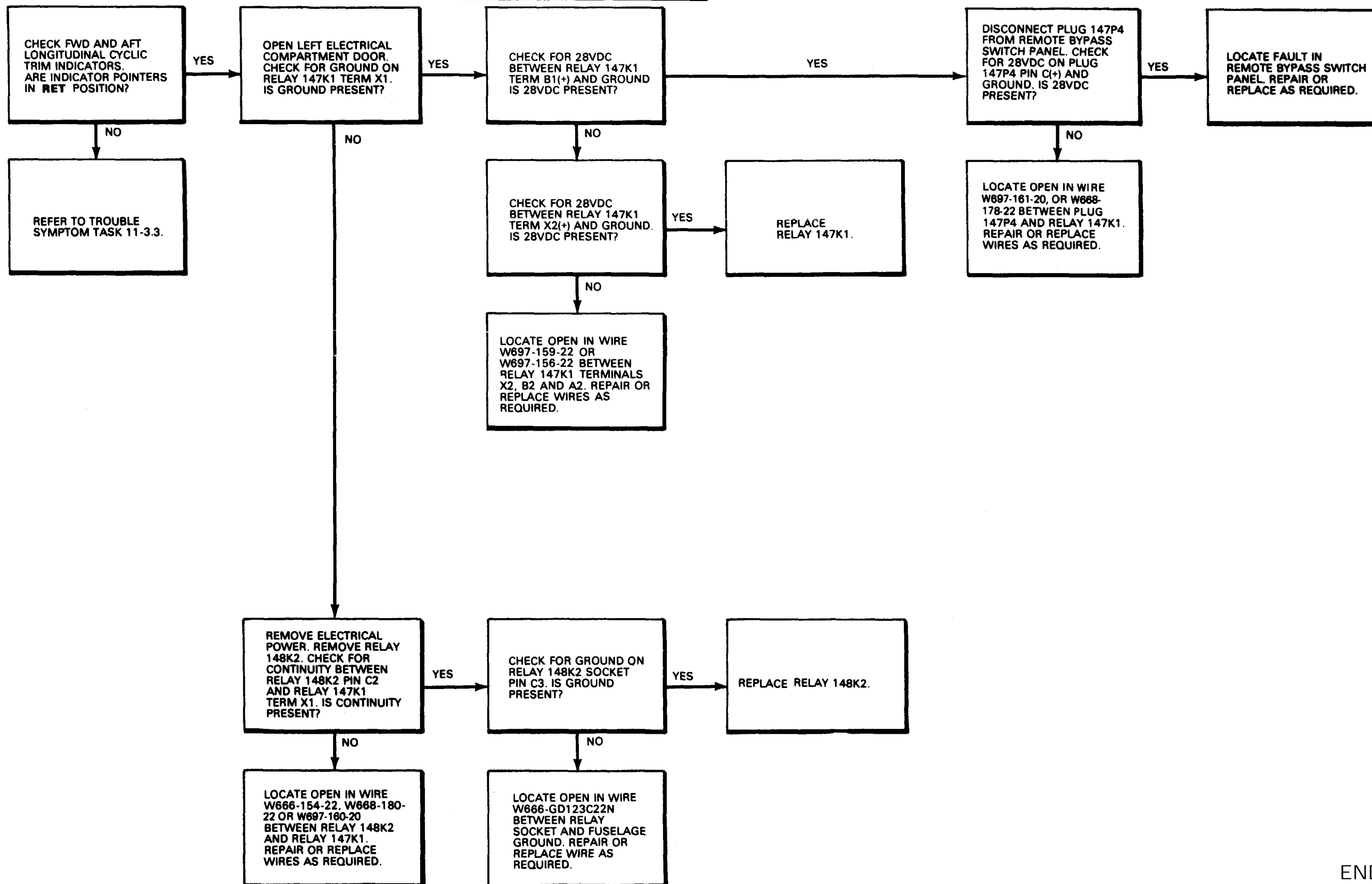

END OF TASK

FAULT ISOLATION PROCEDURE

INITIAL SETUP

Applicable Configurations:

All

Tools:

Electronic Equipment Tool Kit,
NSN 5180-00-064-5178

Materials:

None

Personnel Required:

Avionics Mechanic (2)

References:

TM 55-1520-240-23

Equipment Condition:

TM 55-1520-240-23:

Battery Connected

Electrical Power On

Hydraulic Power Off

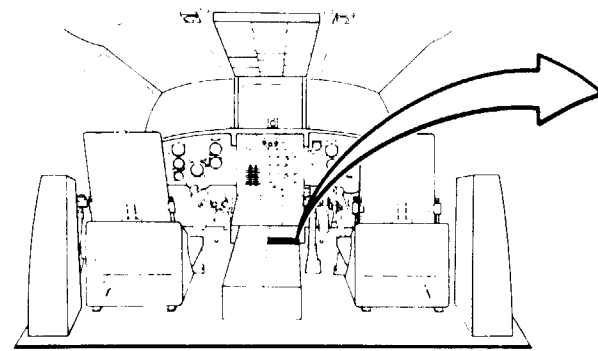

COCKPIT

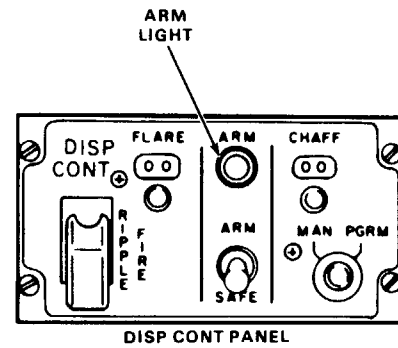

DISP CONT PANEL

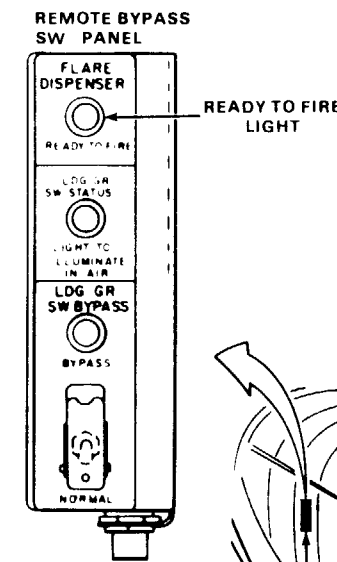

READY TO FIRE LIGHT

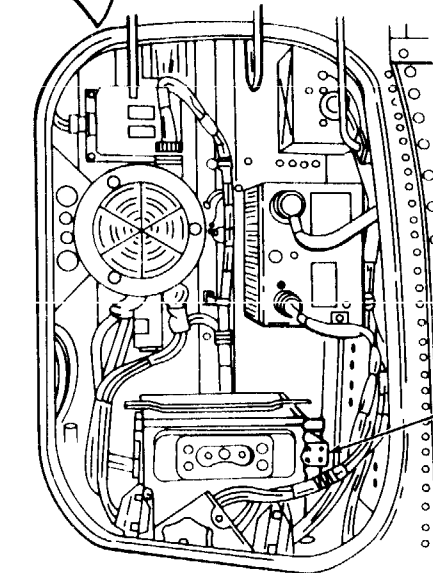
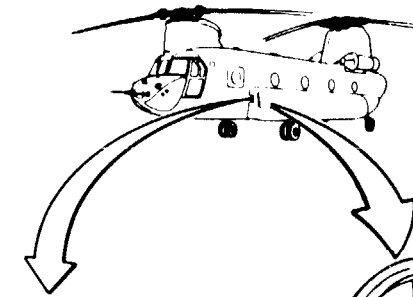

LEFT ELECTRICAL COMPARTMENT SHOWN WITH DOOR OFF FOR CLARITY

RELAY 147K1

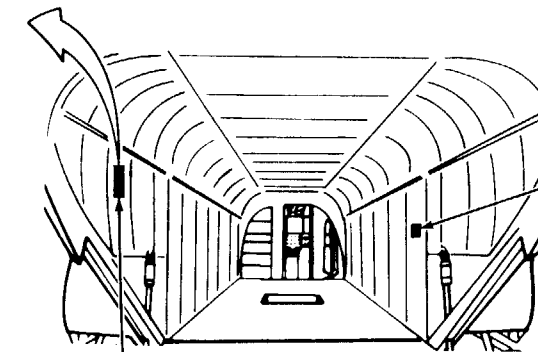

STA 534

RELAY 148K2 STA 482 WL+ 20

D145-12058-SPA

90X54

16-2.8 READY TO FIRE LIGHT DOES NOT COME ON (Continued)

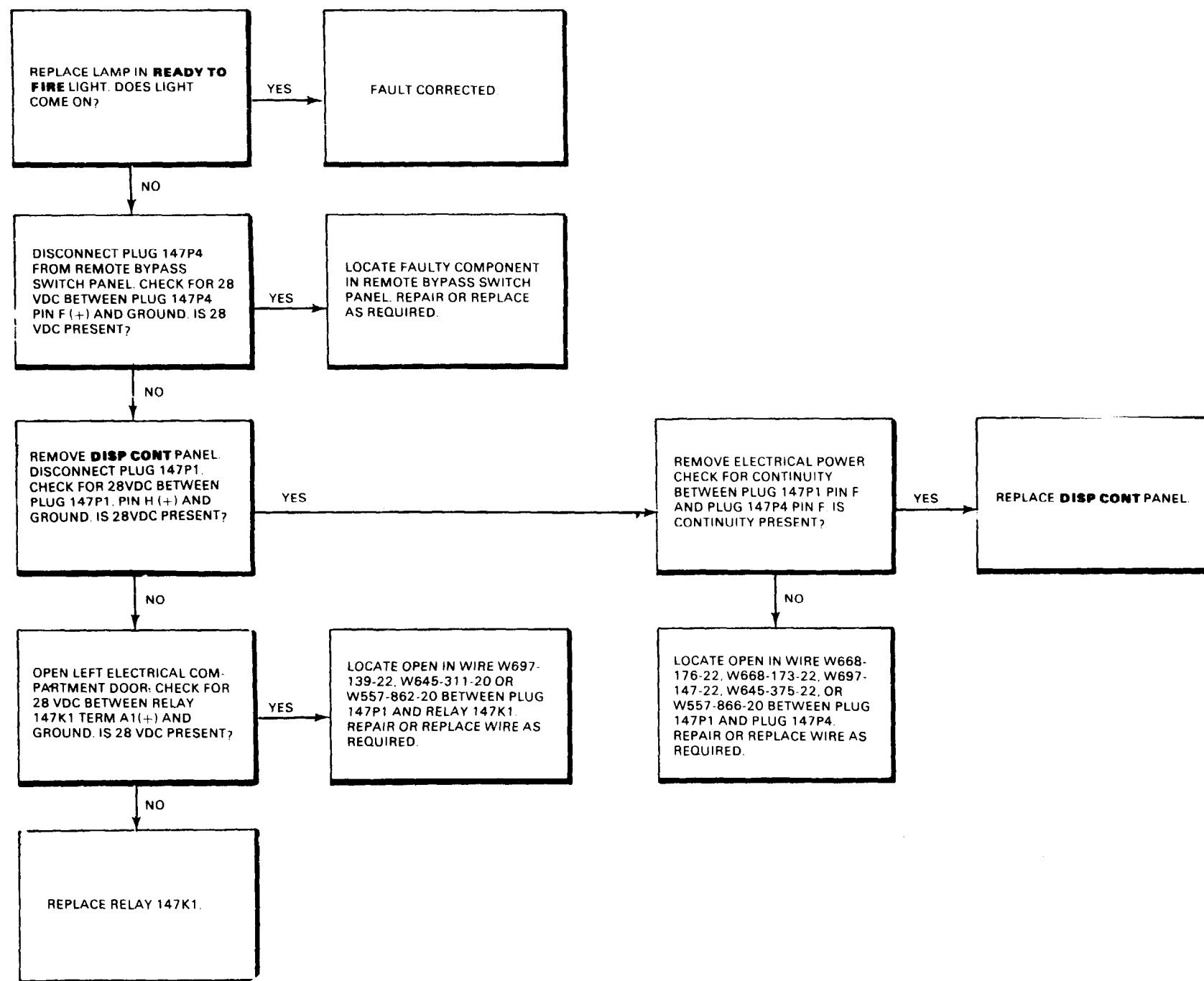

TASK 16-2.9 DELETED

END OF TASK

FAULT ISOLATION PROCEDURE

INITIAL SETUP

Applicable Configurations:

All

Tools:

Electronic Equipment Tool Kit,
NSN 5180-00-064-5178

Materials:

None

Personnel Required:

Avionics Mechanic (2)

References:

TM 55-1520-240-23

Equipment Condition:

TM 55-1520-240-23:

Battery Connected

Electrical Power On

Hydraulic Power Off

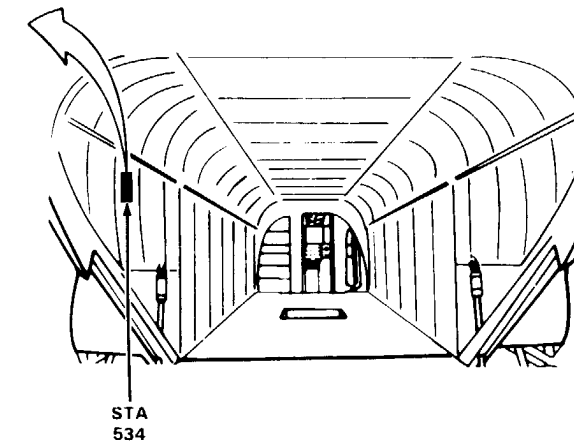
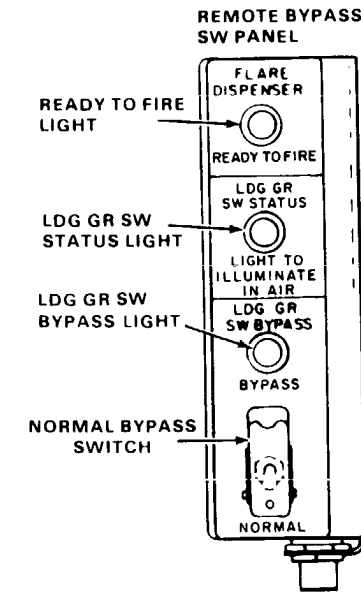

16-2.10 LDG GR SW STATUS READY TO FIRE AND LDG GR SW BYPASS LIGHTS DO NOT COME ON (Continued)

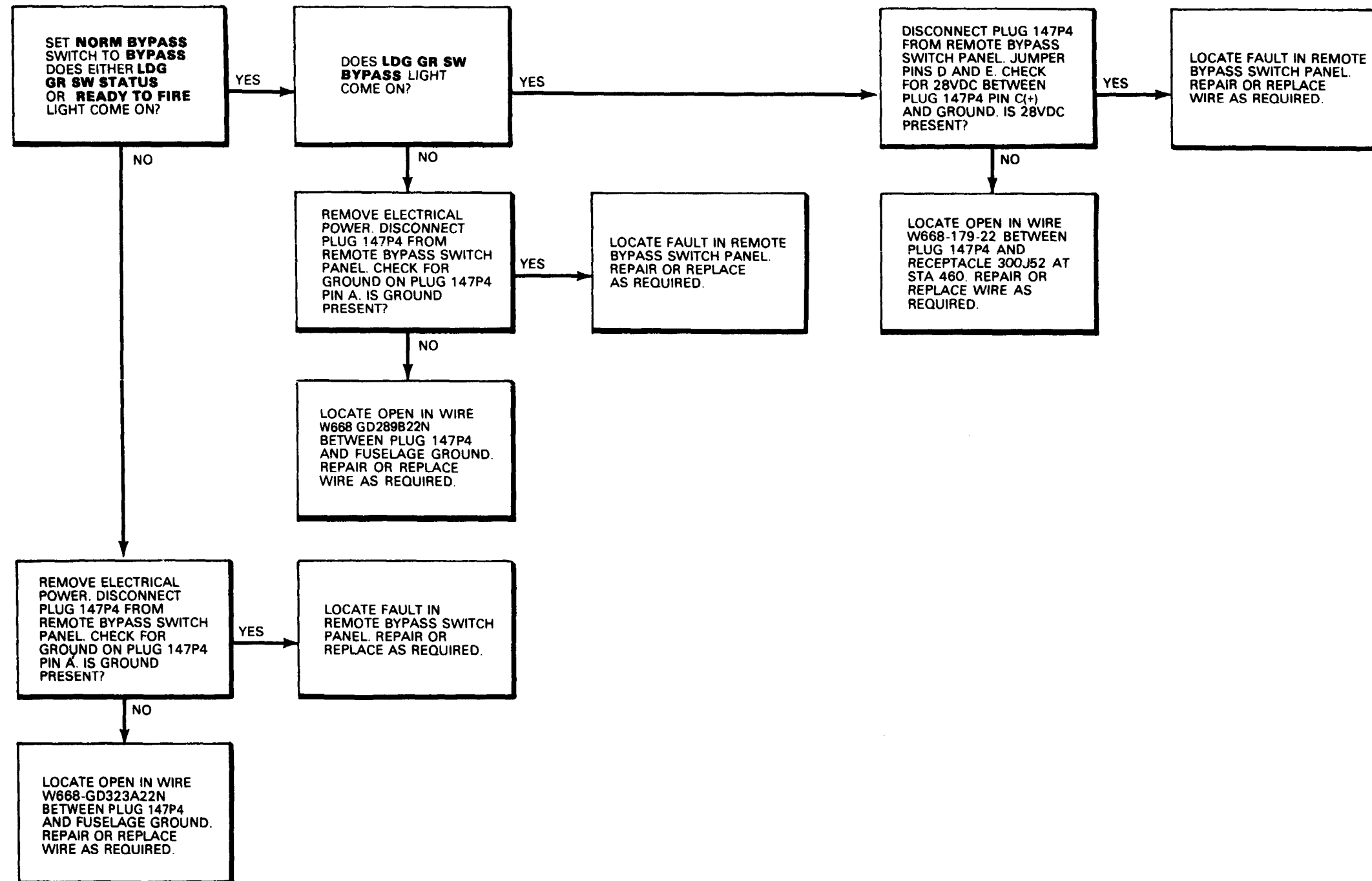

END OF TASK

FAULT ISOLATION PROCEDURE

INITIAL SETUP

Applicable Configurations:

All

Tools:

- Electronic Equipment Tool Kit,
NSN 5180-00-064-5178
- Multimeter

Materials:

None

Personnel Required:

Avionics Mechanic (2)

References:

- TM 9-1095-206-13 & P
- TM 55-1520-240-23

Equipment Condition:

- TM 55-1520-240-23:
- Battery Connected
- Electrical Power On
- Hydraulic Power Off

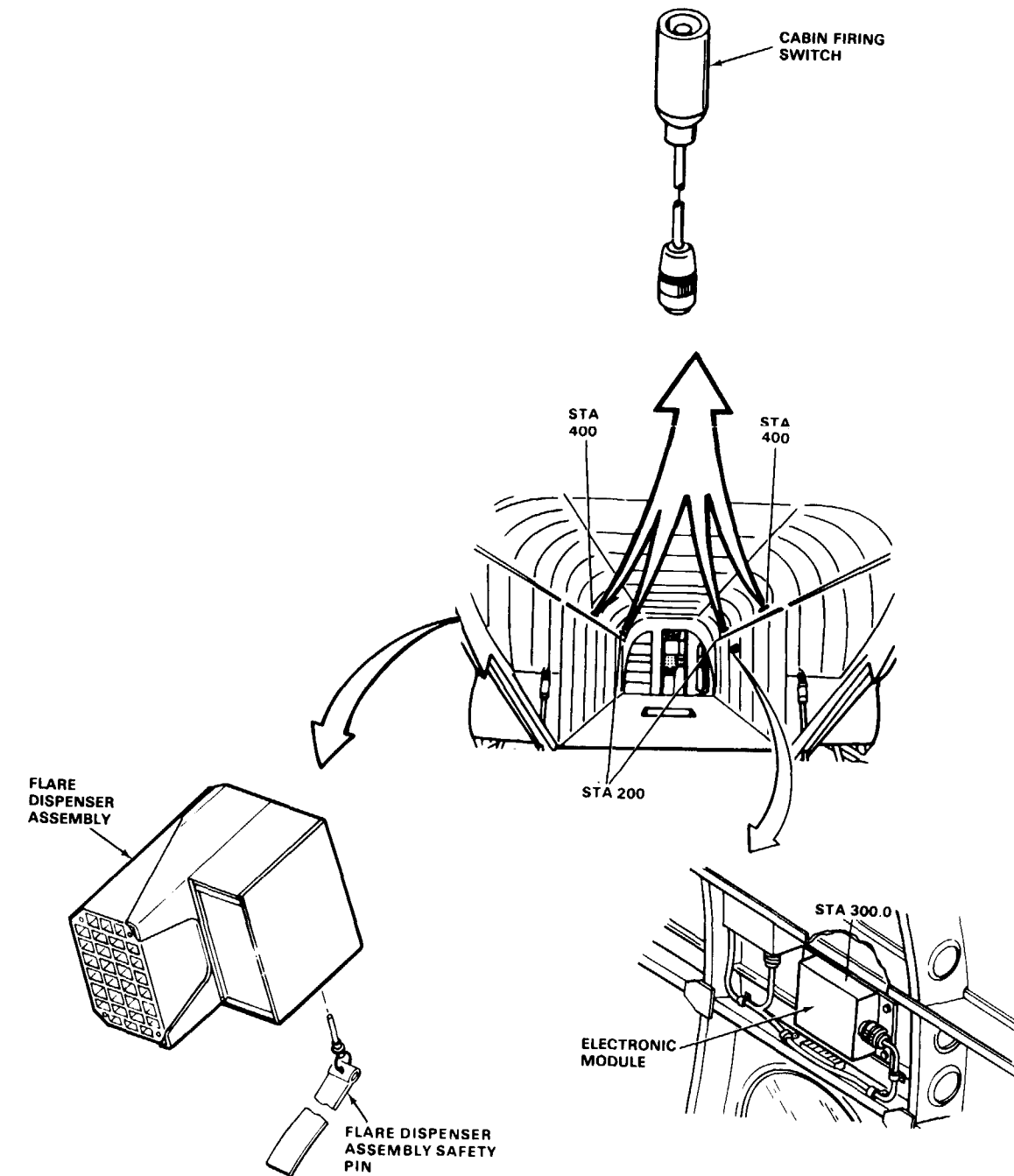
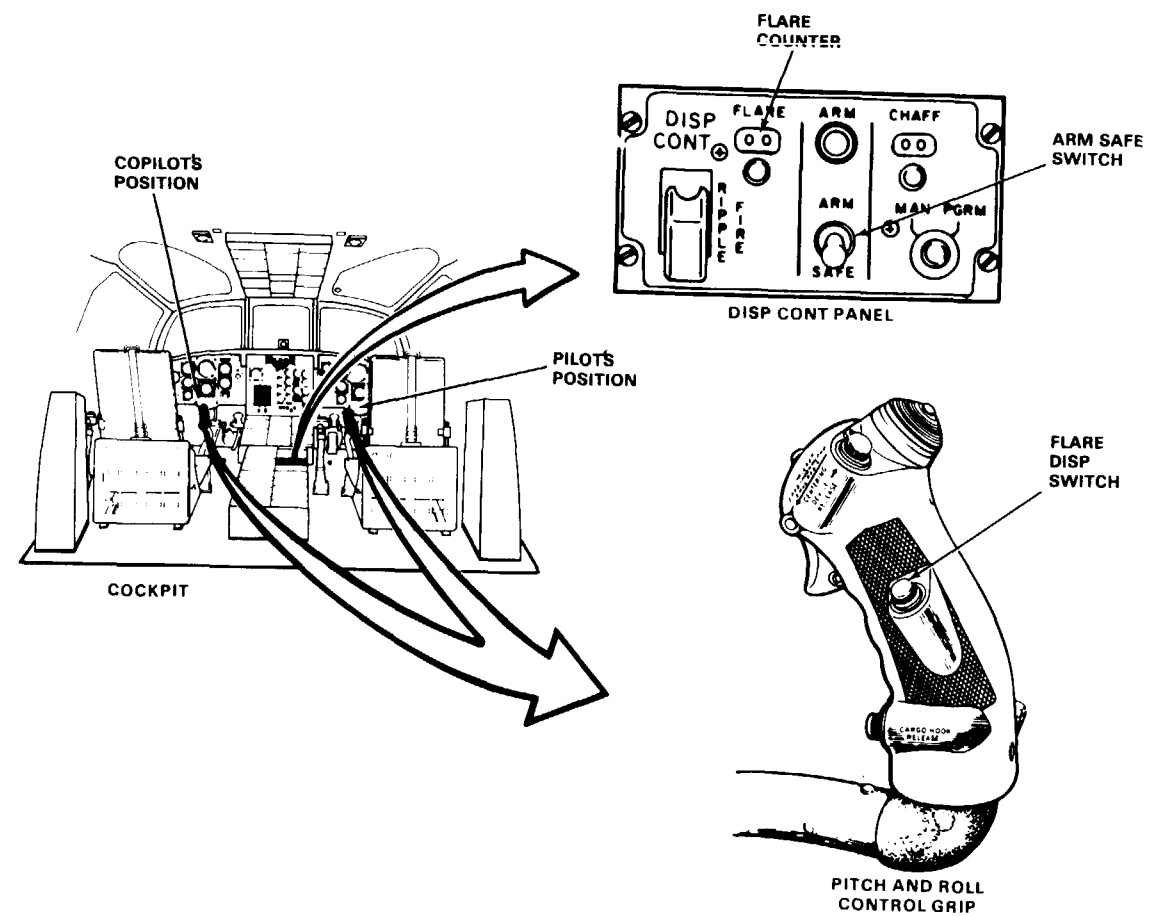

D145-12725-SPA

GO TO NEXT PAGE

16-2.11 FLARE COUNTER SEQUENCES FROM 30 TO 00 WHEN DISP CONT PANEL ARM SAFE SWITCH SET TO ARM (Continued)

16-2.11

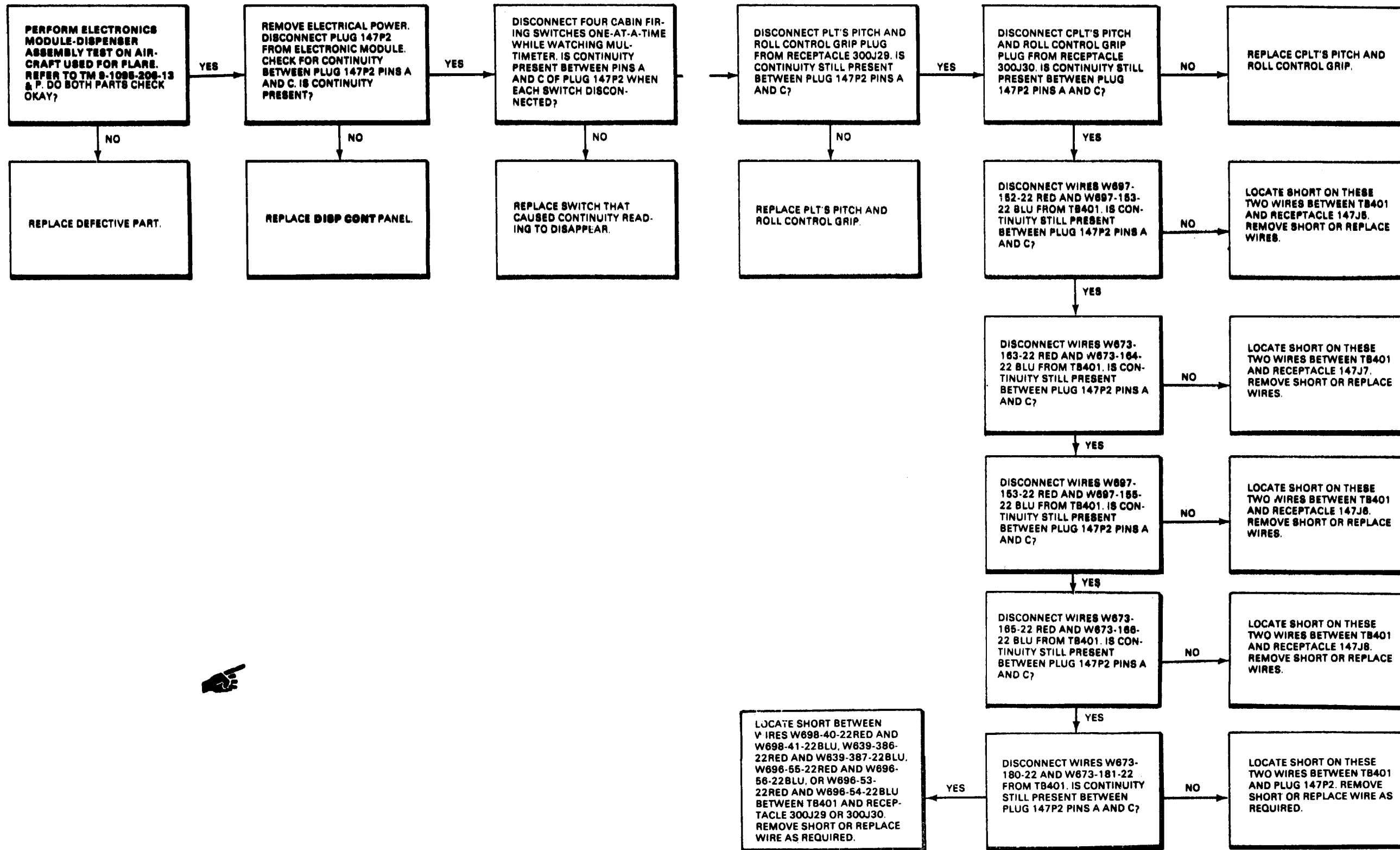

FAULT ISOLATION PROCEDURE

INITIAL SETUP

Applicable Configurations:

All

Tools:

- Electronic Equipment Tool Kit,
NSN 5180-00-064-5178
- Multimeter

Materials:

None

Personnel Required:

Avionics Mechanic (2)

References:

- TM 9-1095-206-13 & P
- TM 55-1520-240-23

Equipment Condition:

- TM 55-1520-240-23:
- Battery Connected
- Electrical Power On
- Hydraulic Power Off

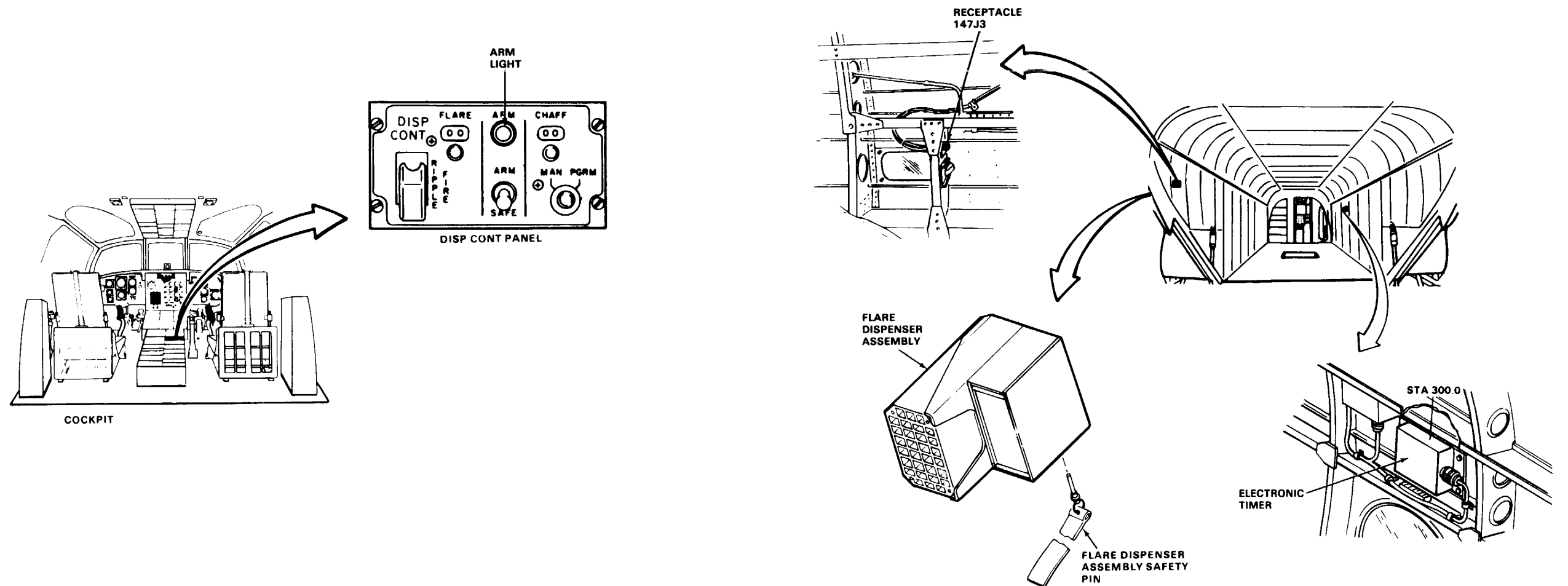

17328

GO TO NEXT PAGE

16-2.12 ARM LIGHT DOES NOT COME ON WHEN ARM SAFE SWITCH SET TO ARM (Continued)

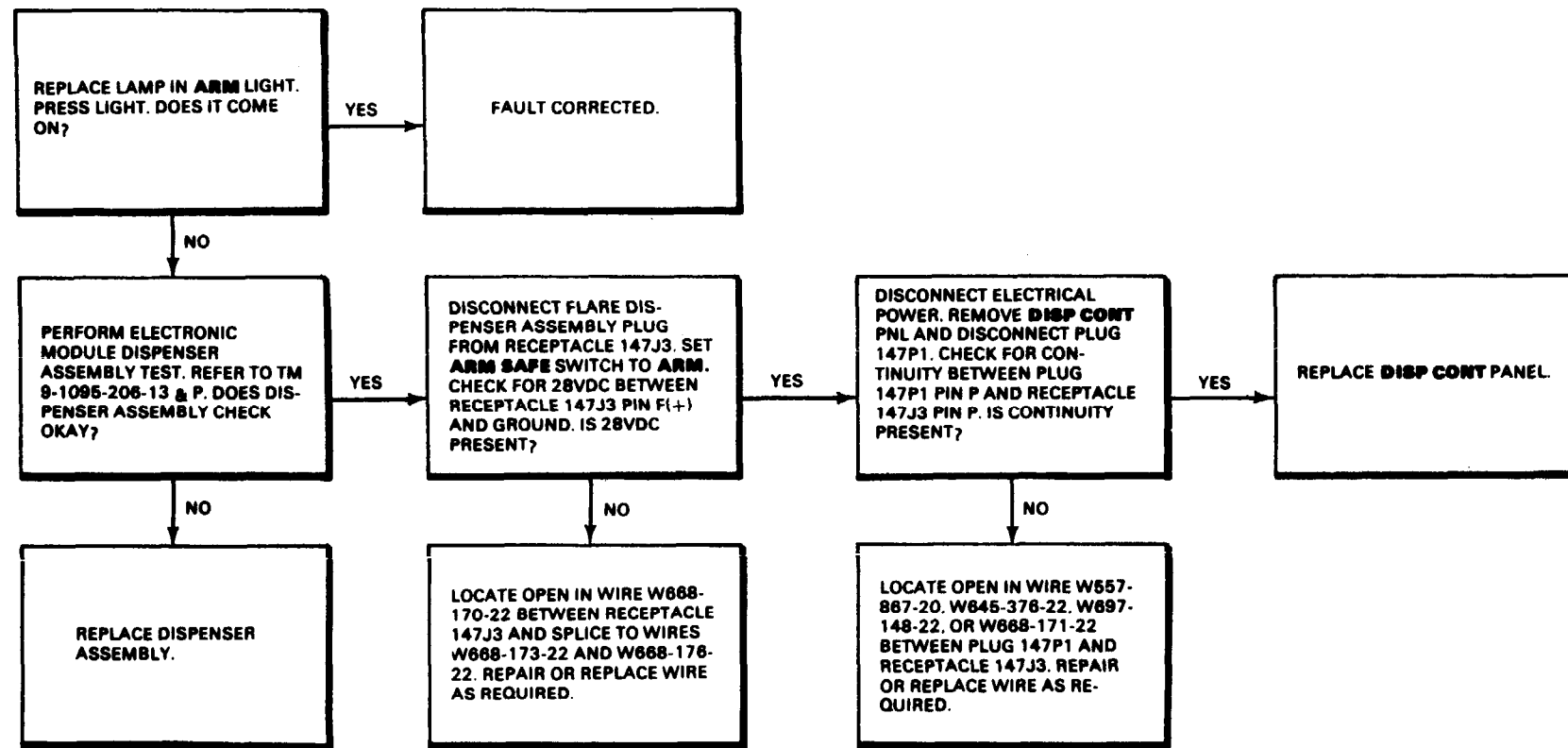

END OF TASK

FAULT ISOLATION PROCEDURE

INITIAL SETUP

Applicable Configurations:

All

Tools:

- Electronic Equipment Tool Kit, NSN 5180-00-064-5178
- Multimeter

Materials:

None

Personnel Required:

Avionics Mechanic (2)

References:

- TM 9-1095-206-13&P
- TM 55-1520-240-23

Equipment Condition:

- BH 55-1520-240-23:
- Battery Connected
- Electrical Power On
- Hydraulic Power Off

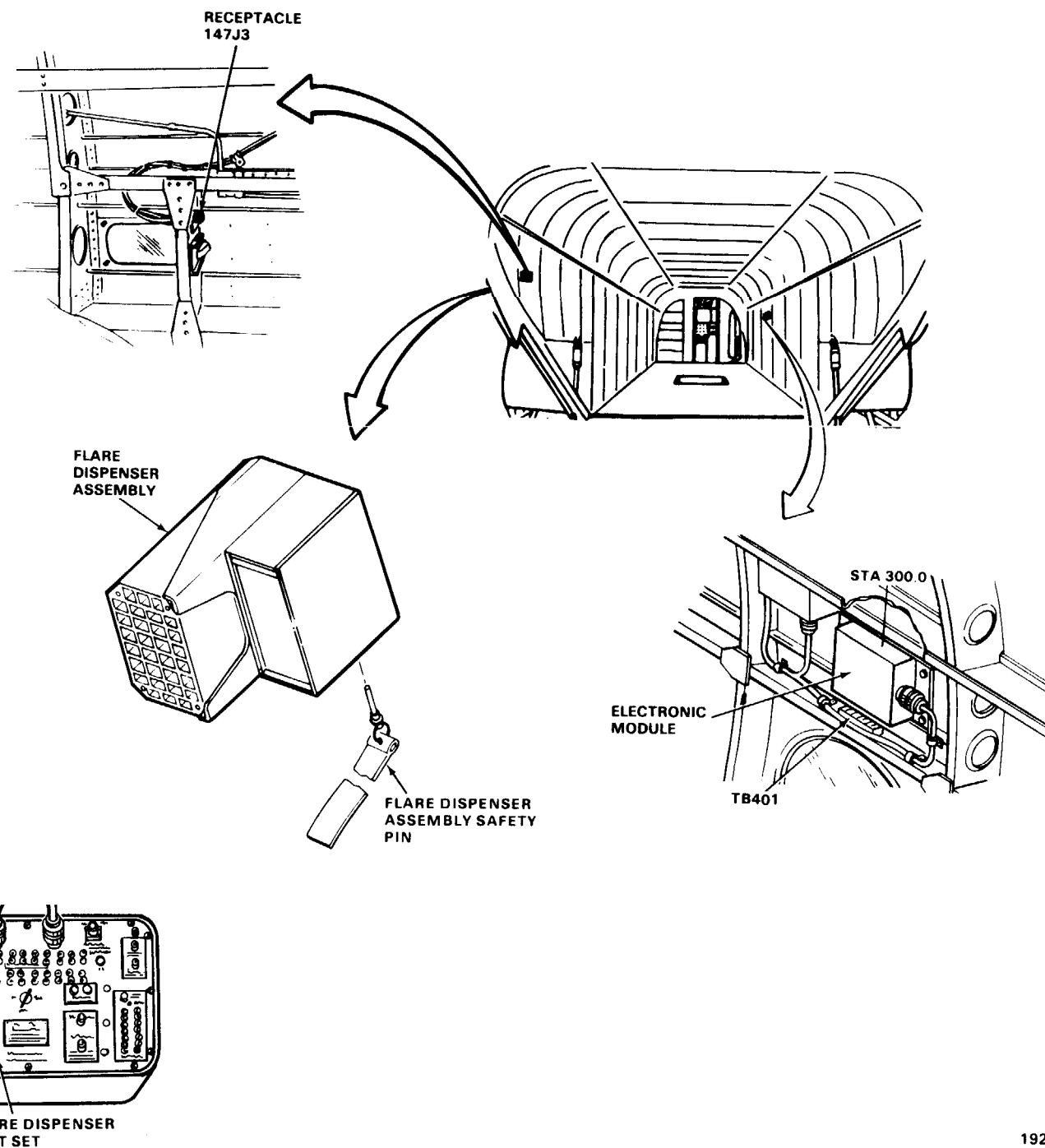
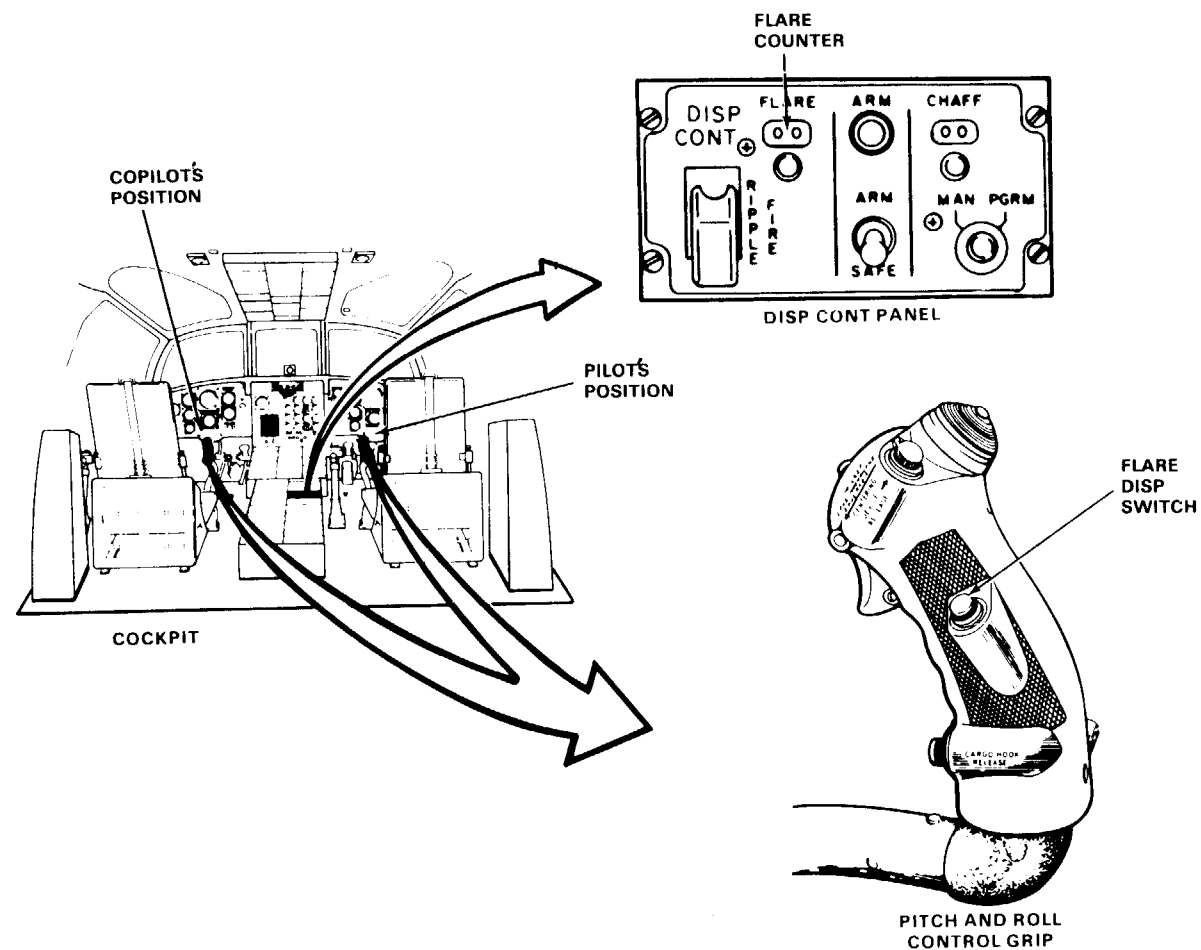

16-2.13 FLARE COUNTER OR TEST SET LIGHTS DO NOT CHANGE WHEN PILOT OR COPILOT FLARE DISP SWITCH PRESSED AND RELEASED (Continued)

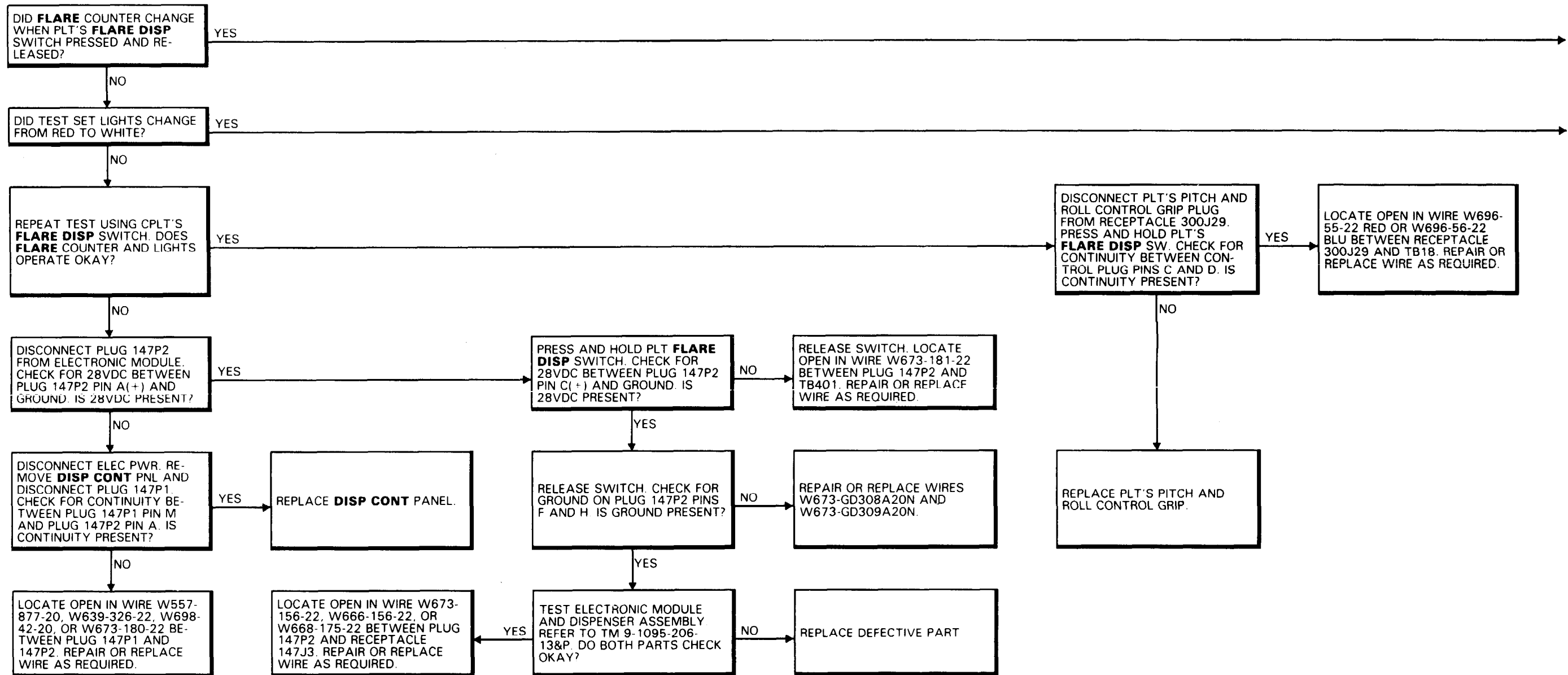

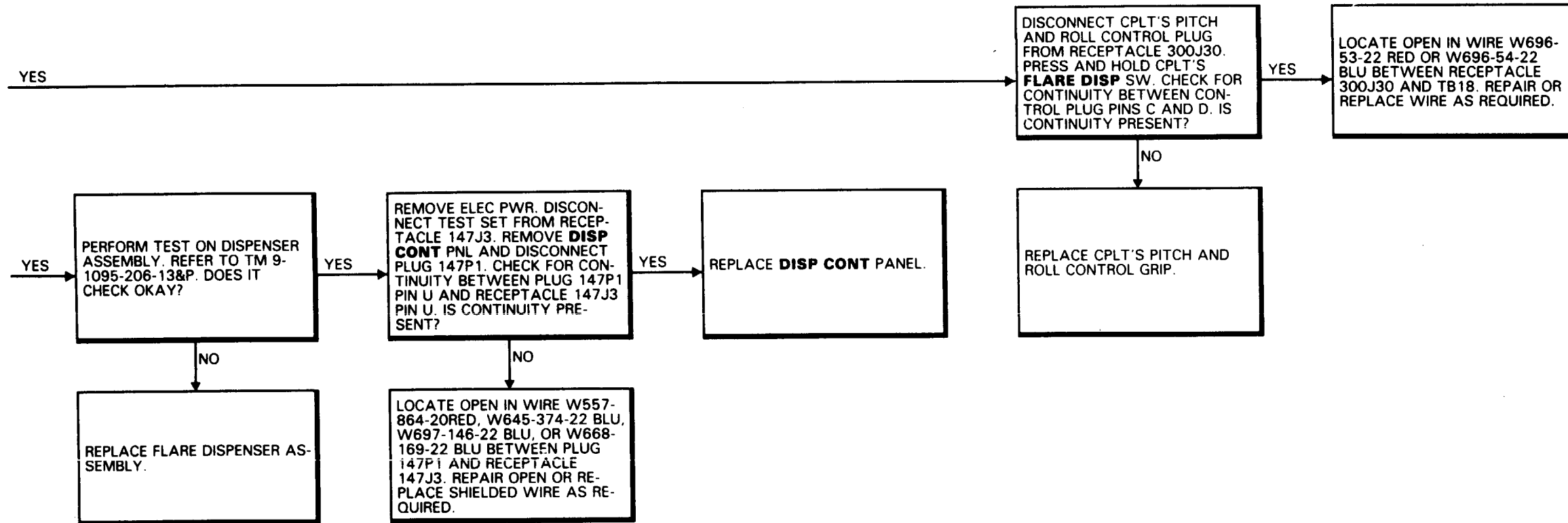

16-2.13 FLARE COUNTER OR TEST SET LIGHTS DO NOT CHANGE WHEN PILOT OR COPILOT FLARE DISP SWITCH PRESSED AND RELEASED (Continued)

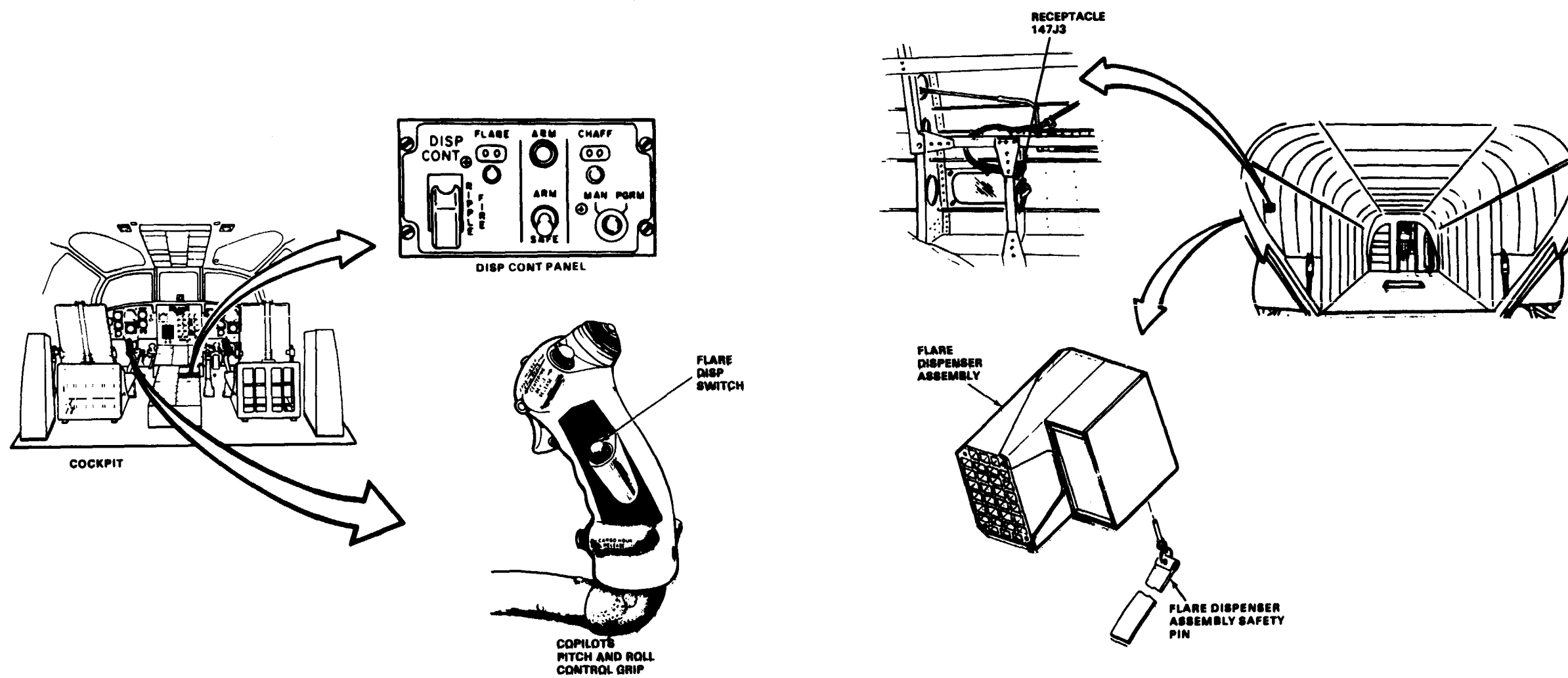

10229

FAULT ISOLATION PROCEDURE

INITIAL SETUP

Applicable Configurations:

All

Tools:

- Electronic Equipment Tool Kit,
NSN 5180-00-064-5178
- Multimeter

Materials:

None

Personnel Required:

Avionics Mechanic (2)

References:

TM 9-1095-206-13&P

TM 55-1520-240-23

Equipment Condition:

TM 55-1520-240-23:

Battery Connected

Electrical Power On

Hydraulic Power Off

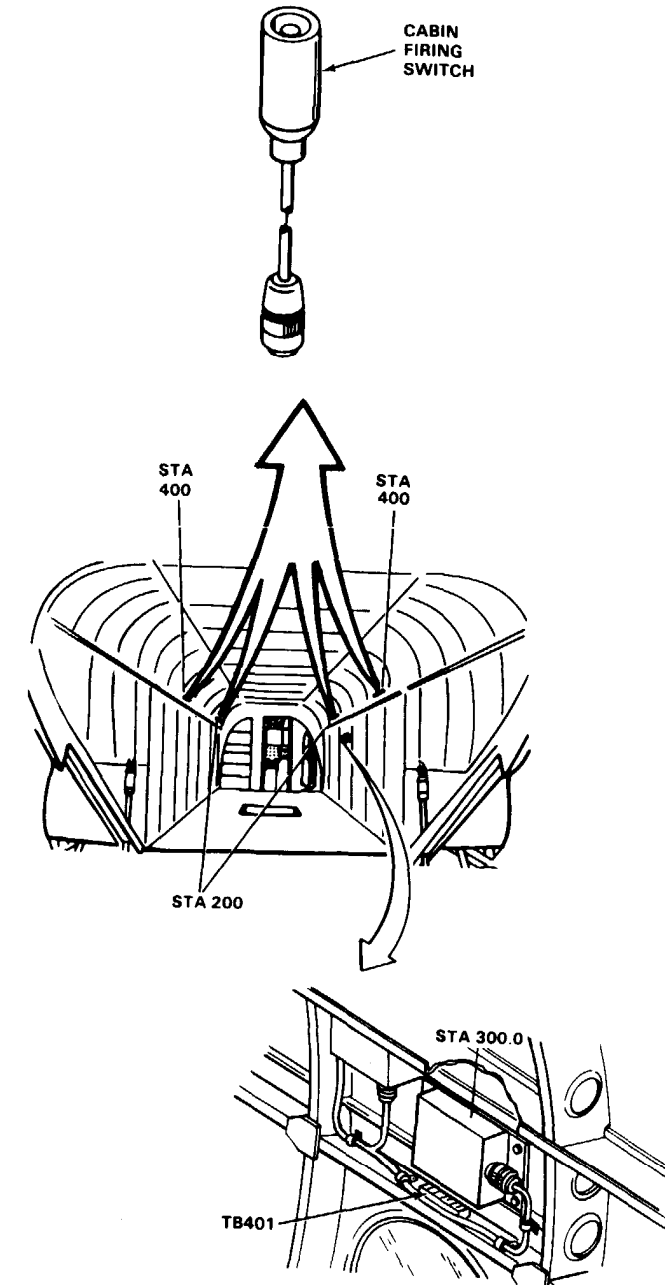

16-2.14 FLARE COUNTER OR TEST SET LIGHTS DO NOT CHANGE WHEN A CABIN FIRING SWITCH
PRESSED AND RELEASED (Continued)

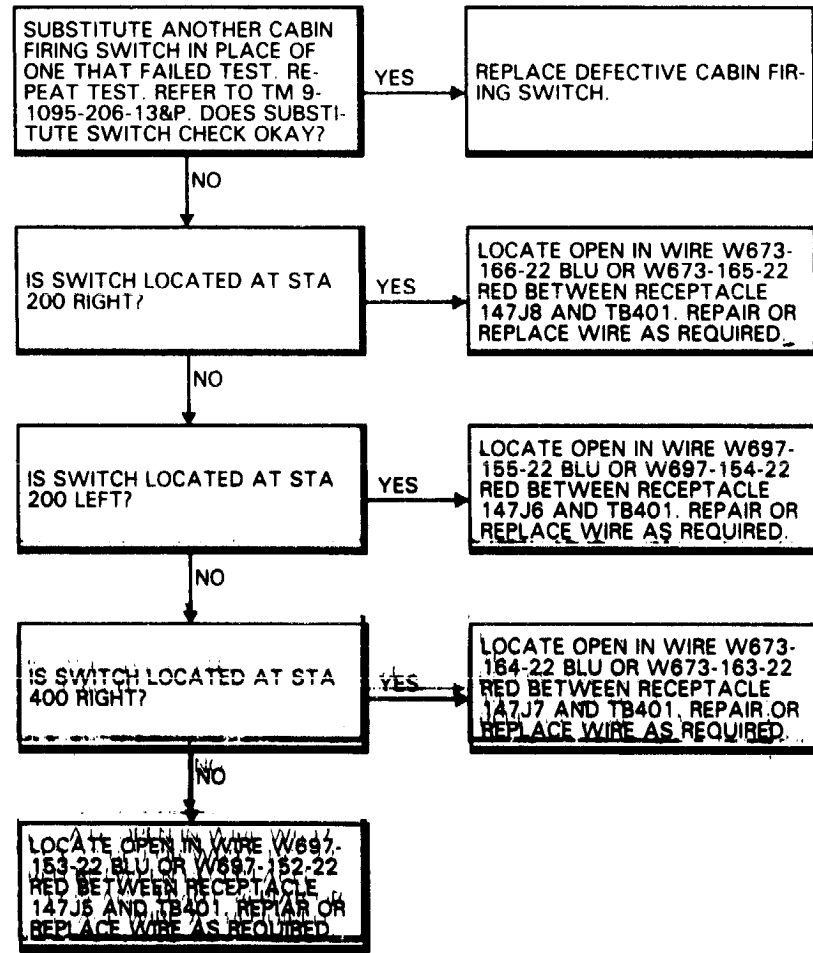

FAULT ISOLATION PROCEDURE

INITIAL SETUP

Applicable Configurations:

All

Tools:

- Electronic Equipment Tool Kit,
NSN 5180-00-064-5178
- Multimeter

Materials:

None

Personnel Required:

Avionics Mechanic (2)

References:

- TM 9-1095-206-13&P
- TM 55-1520-240-23

Equipment Condition:

- TM 55-1520-240-23:
Battery Connected
Electrical Power On
Hydraulic Power Off

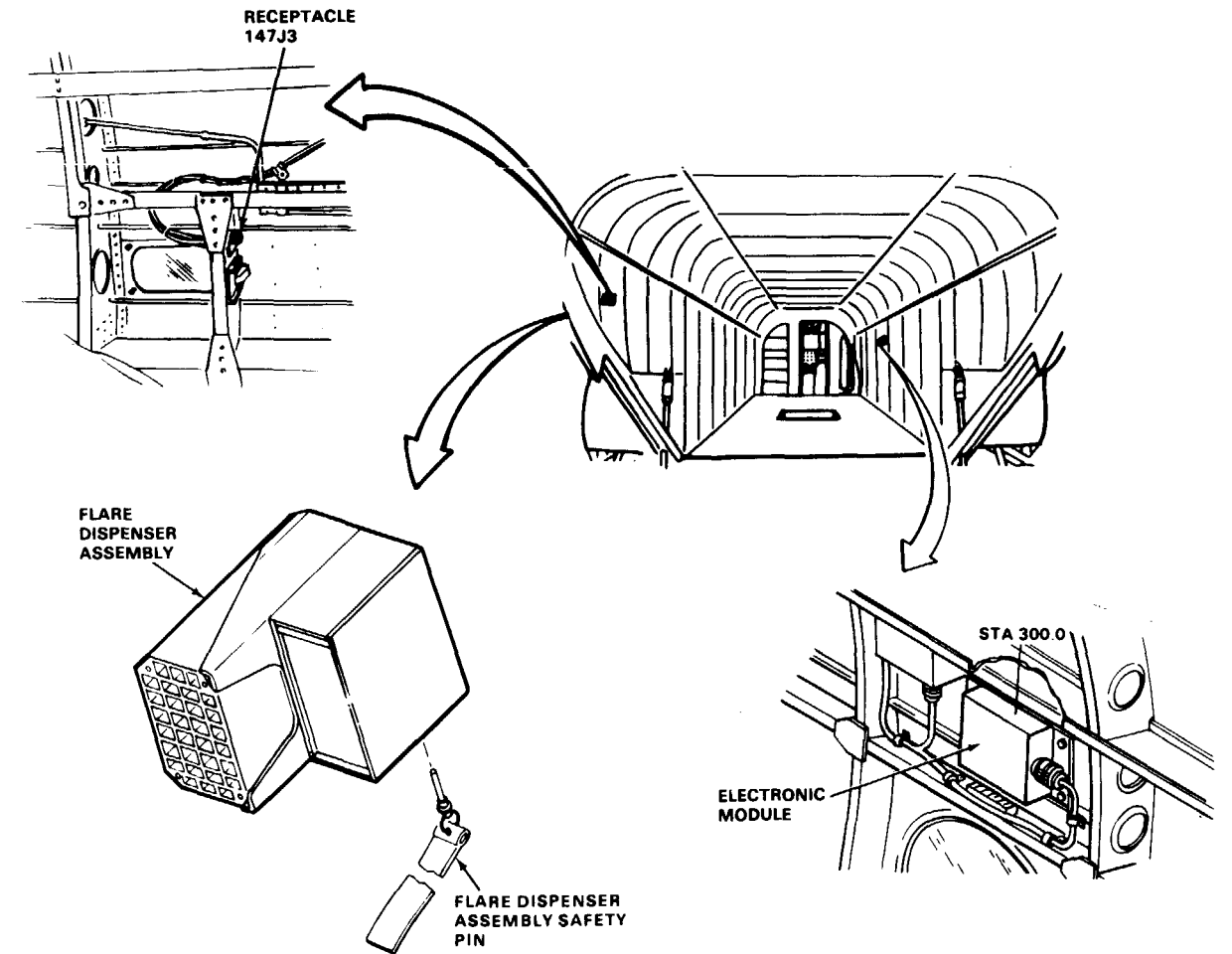
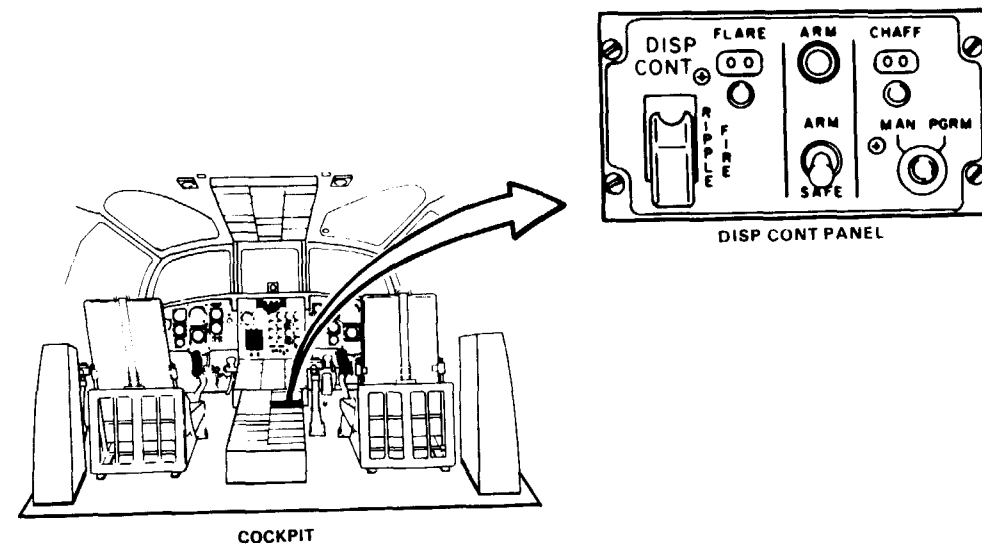

16-2.15 FLARE COUNTER DOES NOT INDICATE 00 WHEN RIPPLE FIRE SWITCH IS HELD UP (Continued)

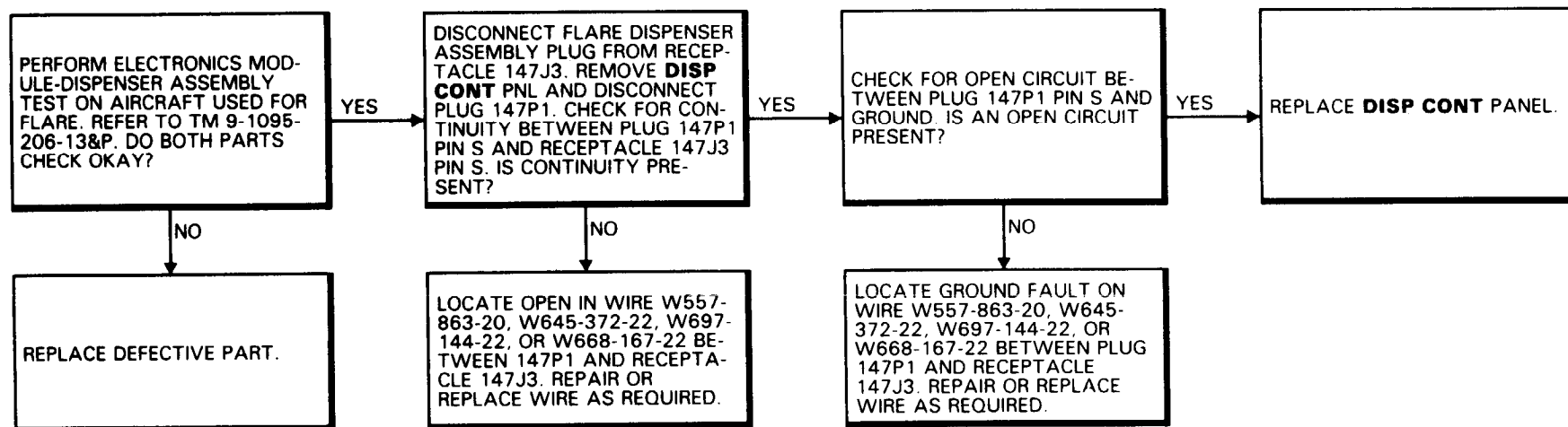

16-3 ENGINE AIR PARTICLE SEPARATOR SYSTEM



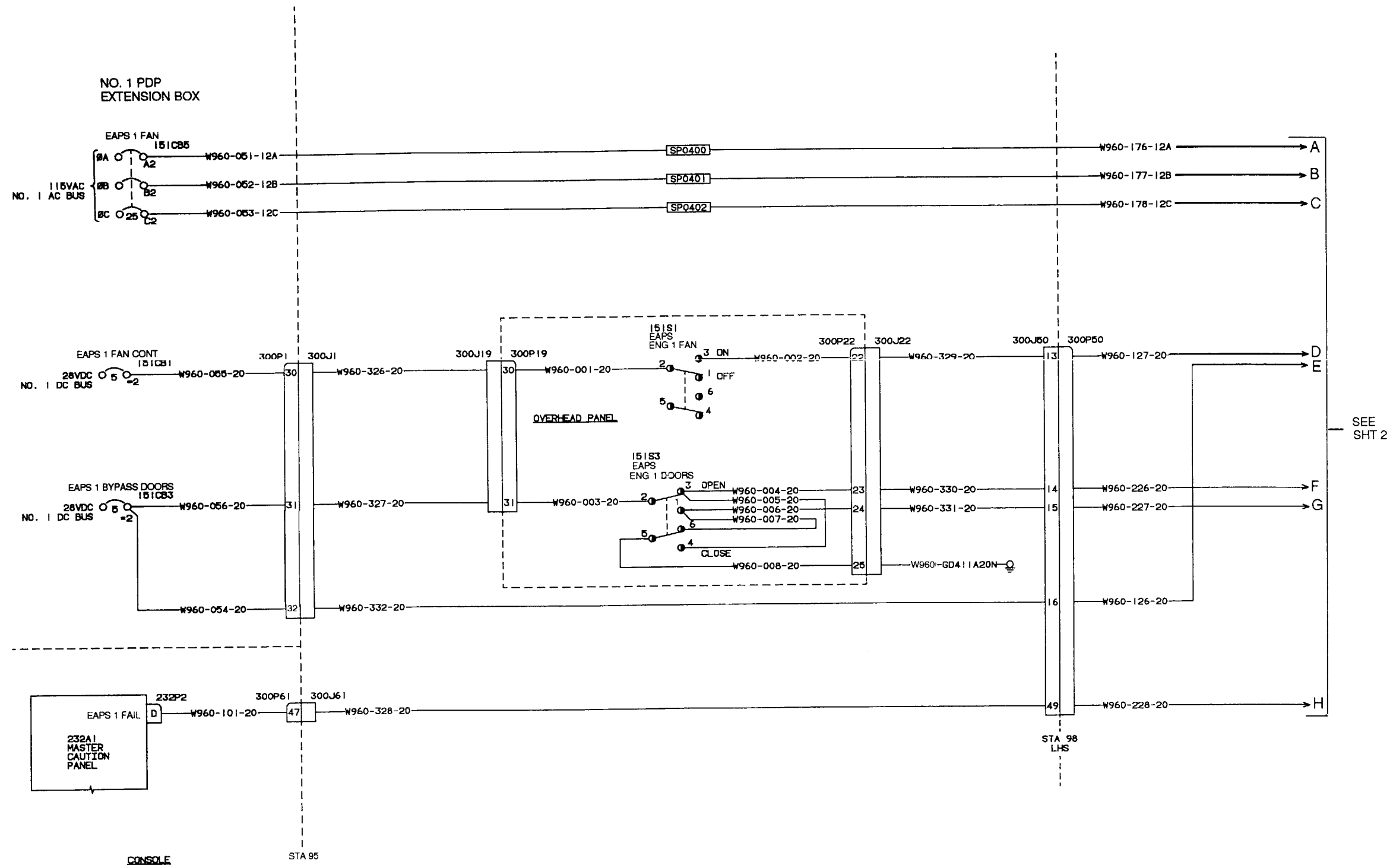

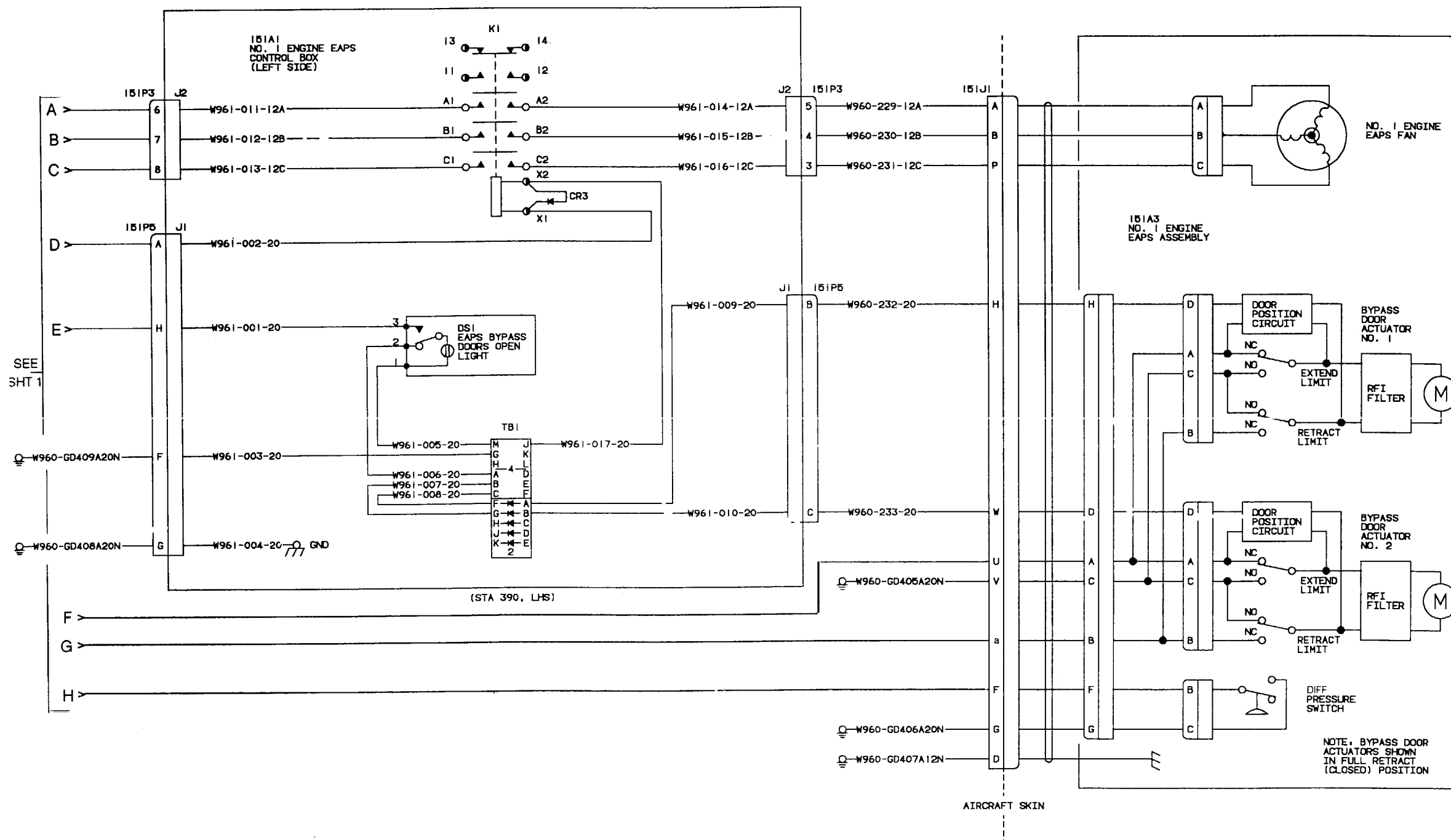

16-3.2 ENGINE NO. 2 AIR PARTICLE SEPARATOR WIRING DIAGRAM

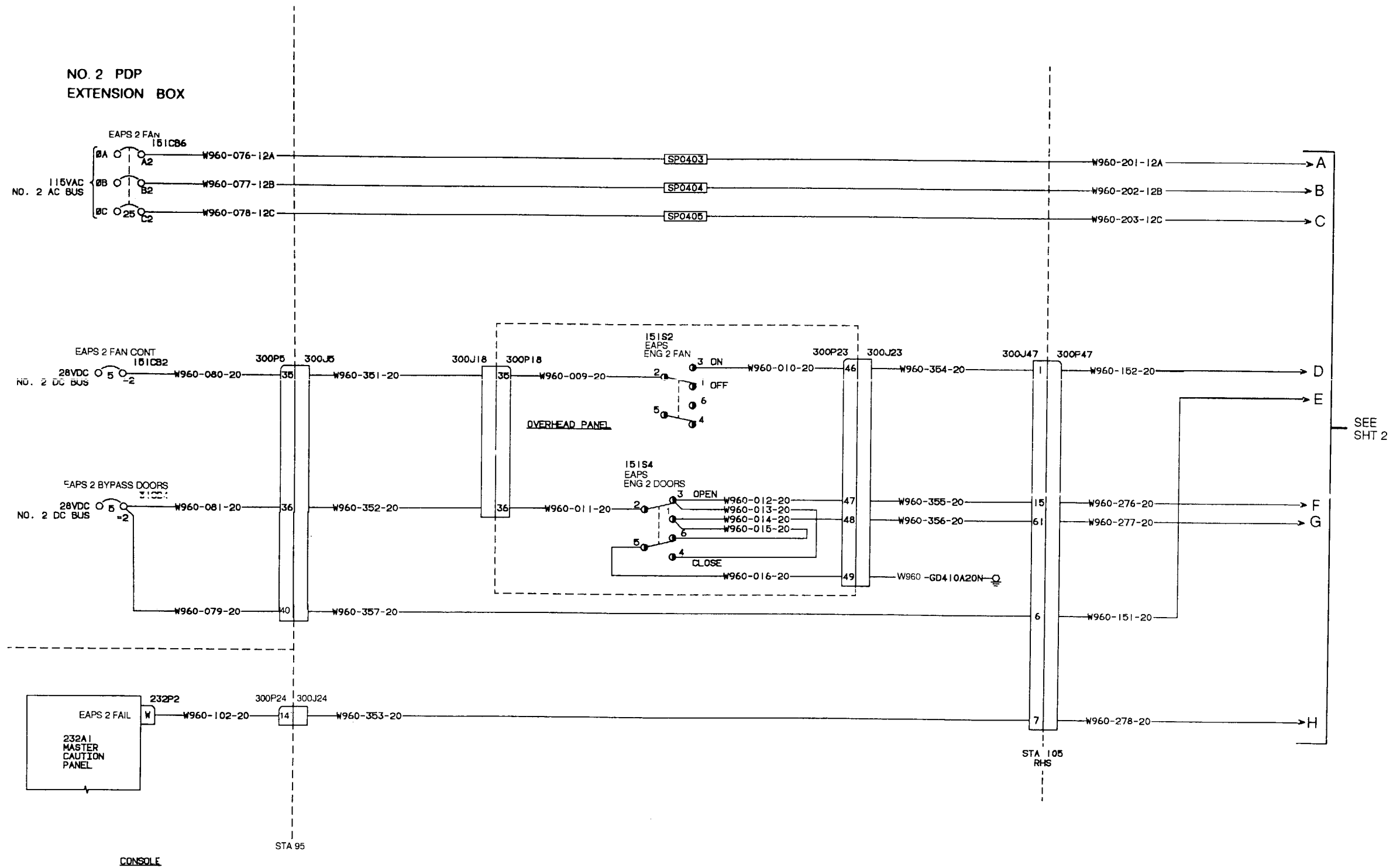

SEE SHT 2

STA 105
RHS

STA 95

CONSOLE

16-3.2 ENGINE NO. 2 AIR PARTICLE SEPARATOR WIRING DIAGRAM (Continued)

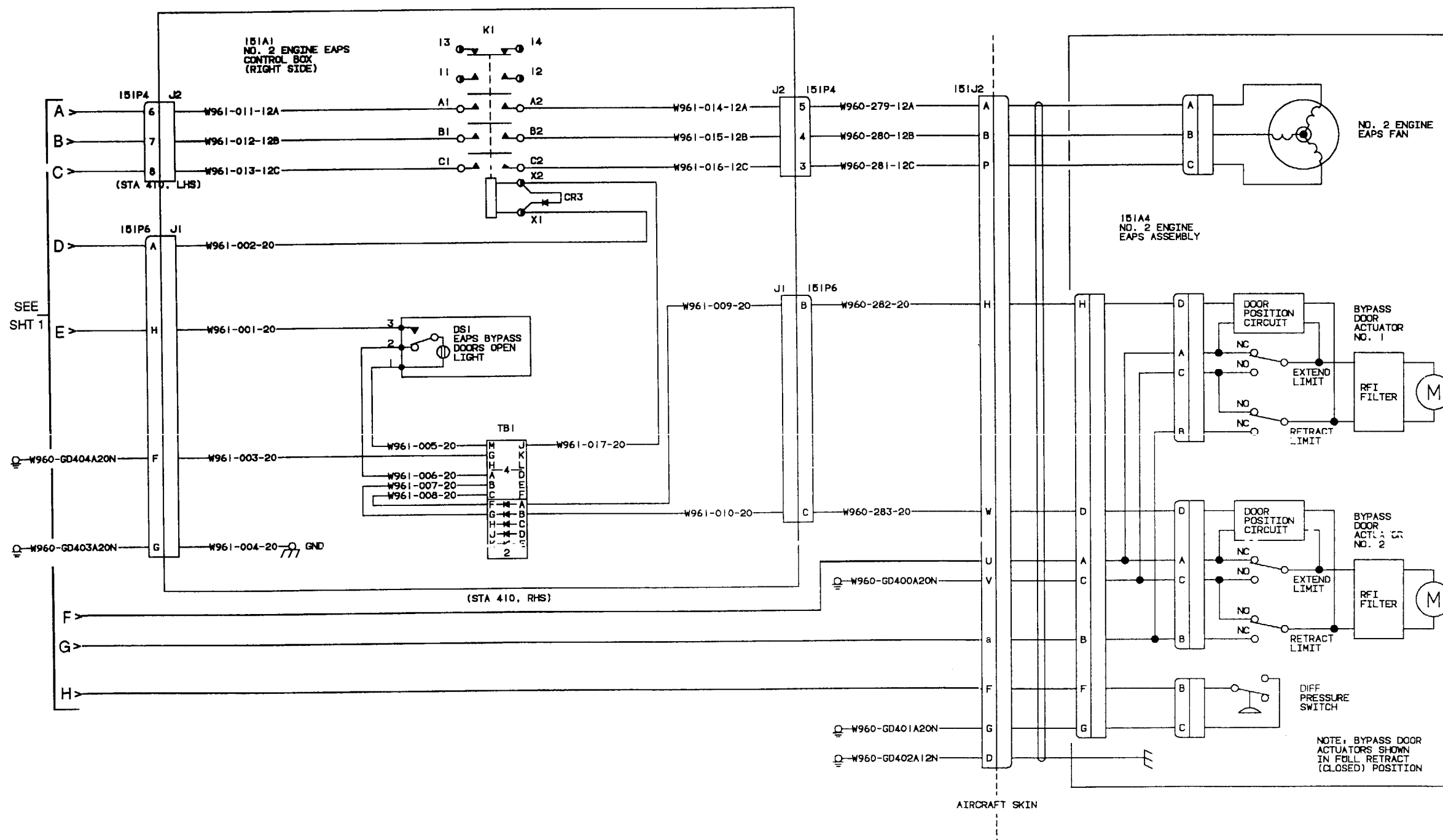

INITIAL SETUP
*Applicable Configurations**
 Helicopters with Engine Air
 Particle Separator Provisions
Took
 None
Materials
 None
Personnel Required:
 Medium Helicopter Repairer

References
 TM 55-1520-240-23

Equipment Condition:
 TM 55-1520-240-23:
 Battery Disconnected
 Electrical Power Off
 Hydraulic Power Off

TASK	RESULT
1. Check NO. 1 PDP extension box (1).	No. 1 PDP extension box (1) should be tightly secured and in good condition. If extension box (1) is loose or damaged, repair or replace it as required.
2. Check NO. 2 PDP extension box (2).	No. 2 PDP extension box (2) should be tightly secured and in good condition. If extension box (2) is loose or damaged, repair or replace it as required.
3. Check EAPS control panel (3).	EAPS control panel (3) and 4 switches should be in good condition. If control panel (3) or switches are damaged, repair or replace them as required.
4. Check NO. 1 EAPS control box (4).	No. 1 EAPS control box (4) should be tightly secured and in good condition. If control box (4) is loose or damaged, repair or replace it as required.
5. Check NO. 2 EAPS control box (5).	No. 2 EAPS control box (5) should be tightly secured and in good condition. If control box (5) is loose or damaged, repair or replace it as required.
6. Check receptacle 151J1 (6).	Receptacle (6) should be tightly secured to aircraft skin and in good condition. All receptacle pins should be in good condition and properly seated. If receptacle or pins are damaged, repair or replace them as required.
7. Check receptacle 151J2 (7).	Receptacle (7) should be tightly secured to aircraft skin and in good condition. All receptacle pins should be in good condition and properly seated. If receptacle or pins are damaged, repair or replace them as required.

FOLLOW-ON MAINTENANCE:
 None

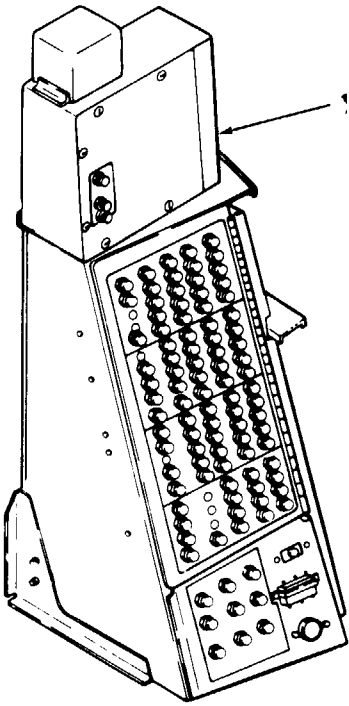
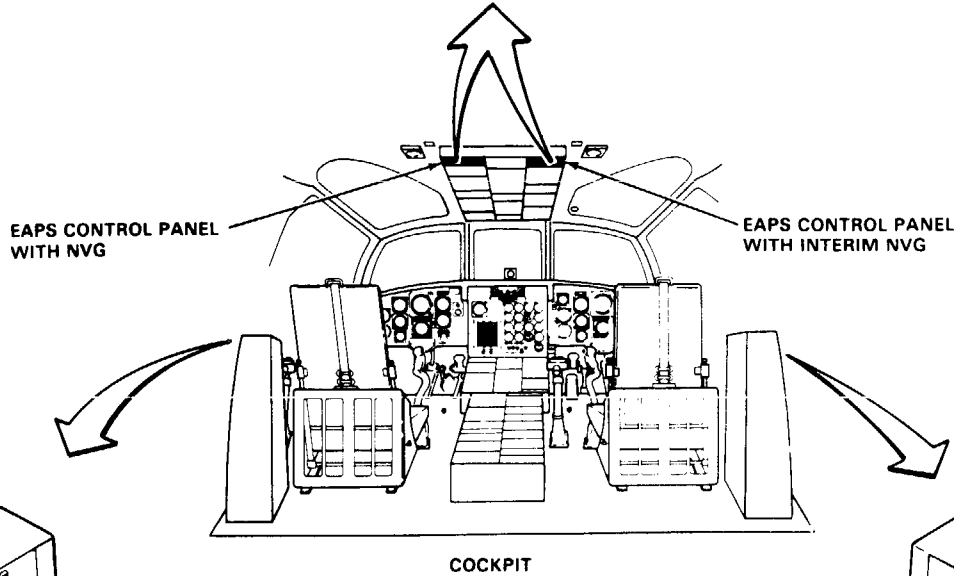
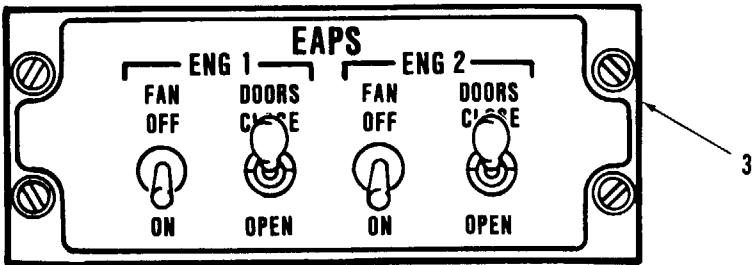

NO. 1 POWER DISTRIBUTION PANEL

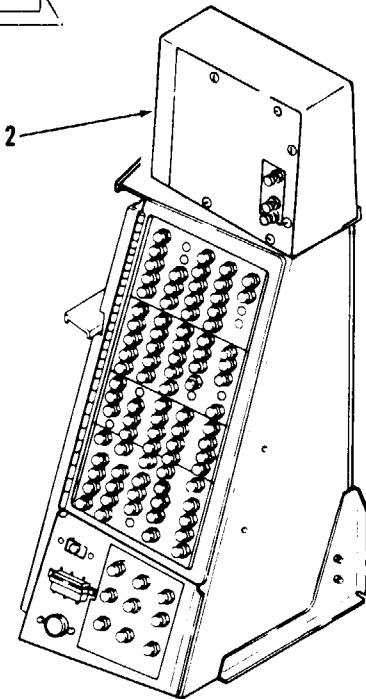

NO. 2 POWER DISTRIBUTION PANEL

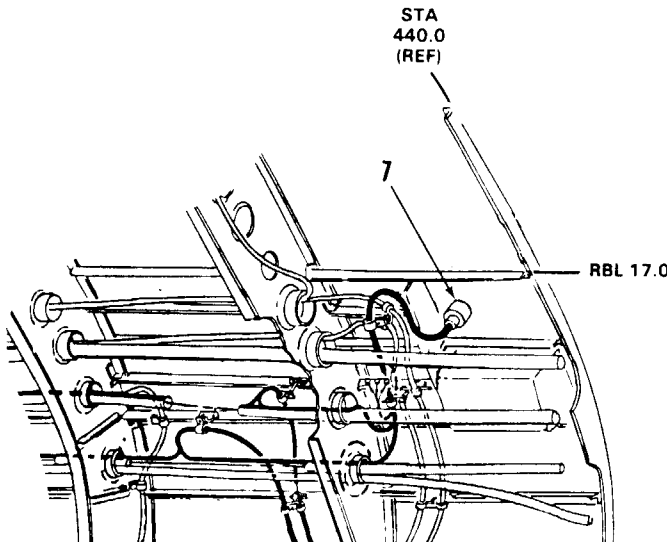
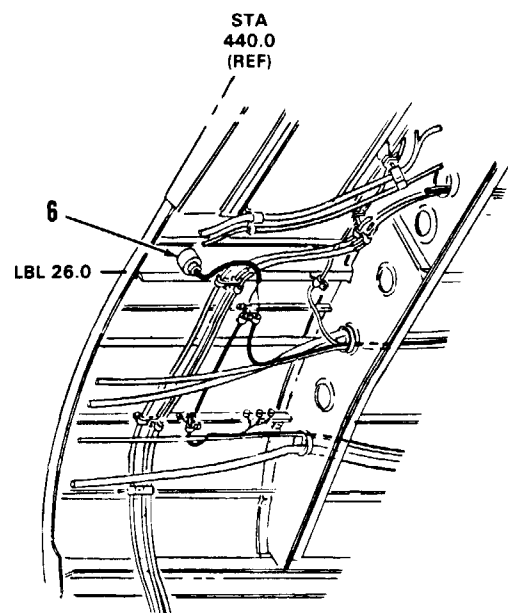
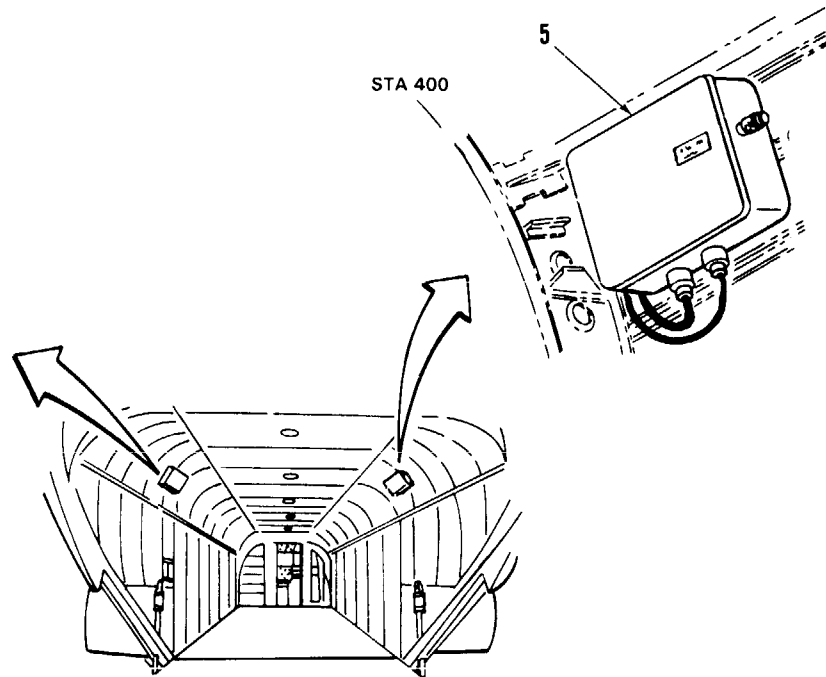
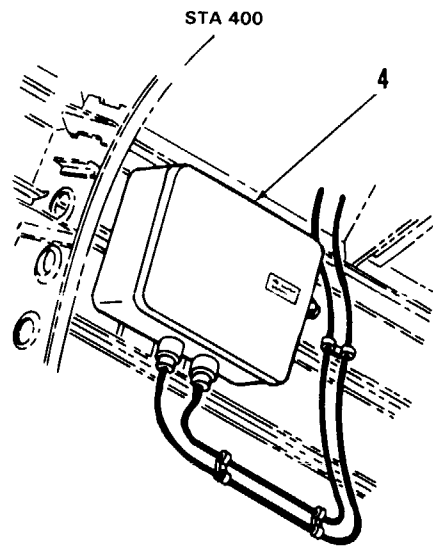

5-3.4 ENGINE AIR PARTICLE SEPARATOR PROVISIONS OPERATION CHECK

INITIAL SETUP

Applicable Configurations:
Helicopters with Engine Air Particle Separator Provisions

Tools:
Electrical Repairer's Tool Kit, NSN 5180-00-323-4915
Multimeter

Materials:
None

Personnel Required:
Aircraft Electrician (2)

References:
TM 55-1520-240-23

Equipment Condition:
TM 55-1520-240-23:
Battery Connected
Electrical Power On
Hydraulic Power Off
Visual Check of Engine Air Particle Separator Provisions Performed

TASK	RESULT
<i>CHECK CIRCUIT BREAKERS</i>	
1. On NO. 1 PDP extension box, close the following circuit breakers: EAPS 1 FAN (1) EAPS 1 FAN CONT (2) EAPS 1 BYPASS DOORS (3)	If any circuit breaker opens, close it. If EAPS 1 FAN circuit breaker (1) opens again, go to task 4-5. If EAPS 1 FAN CONT circuit breaker (2) opens again, go to task 4-5. If EAPS 1 BYPASS DOORS circuit breaker (3) opens again, go to task 4-5.
2. On NO. 2 PDP extension box, close the following circuit breakers: EAPS 2 FAN (4) EAPS 2 FAN CONT (5) EAPS 2 BYPASS DOORS (6)	If any circuit breaker opens, close it. If EAPS 2 FAN circuit breaker (4) opens again, go to task 4-6. If EAPS 2 FAN CONT circuit breaker (5) opens again, go to task 4-6. If EAPS 2 BYPASS DOORS circuit breaker (6) opens again, go to task 4-6.
3. On NO. 1 Engine EAPS control box (7), press to test EAPS BYPASS DOORS OPEN light (8).	EAPS BYPASS DOORS OPEN light (8) shall come on momentarily. If it does not, replace bulb. Press to test light again. If light still does not come on, go to task 4-7.
4. On NO. 2 Engine EAPS control box (9), press to test EAPS BYPASS DOORS OPEN light (10).	EAPS BYPASS DOORS OPEN light (10) shall come on. If it does not, replace bulb. Press to test light again. If light still does not come on, go to task 16-3.7.
5. ON EAPS control panel (11) set EAPS ENG 1 FAN switch (12) to ON. At receptacle 151J1 (13) check for 115VAC between pin A and ground, pin B and ground, and pin P and ground.	115VAC should be present on pins A, B and P. If 115VAC is not present on any pin, go to task 16-3.8.
6. On EAPS control panel (11) set EAPS ENG 1 DOORS switch (14) to OPEN. At receptacle 151J1 (13) check for 28VDC between pin U and ground. Check for ground on pin a.	If 28VDC is not present on pin U, go to task 16-3.9. If ground is not present on pin a, go to task 16-3.10.
7. On EAPS control panel (11) set EAPS ENG 1 DOORS switch (14) to CLOSE. At receptacle 151J1 (13) check for 28VDC between pin a and ground. Check for ground on pin U.	If 28VDC is not present on pin a, go to task 16-3.11. If ground is not present on pin U, go to task 16-3.12.

TASK	RESULT
8. Check for ground on receptacle 151J1 pins G, D and V.	If ground is not present, repair or replace wire between receptacle and ground stud.
9. At receptacle 151J1 (13) place a jumper wire between pins F & G. On NO. 1 PDP, close CAUTION PNL LIGHTING circuit breaker (15).	On Master Caution Panel, EAPS 1 FAIL capsule (16) shall come on. If it does not, go to task 16-3.13.
10. On EAPS control panel (11), set EAPS ENG 2 FAN switch (17) to ON. At receptacle 151J2 (18), check for 115VAC between pin A and ground, pin B and ground, and pin P and ground.	115VAC shall be present on pins A, B and P. If 115VAC is not present on any pin, go to task 16-3.14.
11. ON EAPS control panel (14) set EAPS ENG 2 DOORS switch (19) to OPEN. At receptacle 151J2 (18) check for 28VDC between pin U and ground. Check for ground on pin a.	If 28VDC is not present on pin U, go to task 16-3.15. If ground is not present on pin a, go to task 16-3.16.
12. On EAPS control panel (14) set EAPS ENG 2 DOORS switch (19) to CLOSE. At receptacle 151J2 (18) check for 28 VDC between pin a and ground. Check for ground on pin U.	If 28VDC is not present on pin a, go to task 16-3.17. If ground is not present on pin U, go to task 16-3.18.
13. Check for ground on receptacle 151J2 pins G, D and V.	If ground is not present, repair or replace wire between receptacle and ground stud,
14. At receptacle 151 J2 (18), place a jumper wire between pins F & G.	On master caution panel, EAPS 2 FAIL capsule (20) shall come on. If it does not, go to task 16-3.19.
15. Remove jumper wires from receptacles 151J1 and 151J2.	

FOLLOW ON MAINTENANCE:
Turn Off Electrical Power
Disconnect Battery

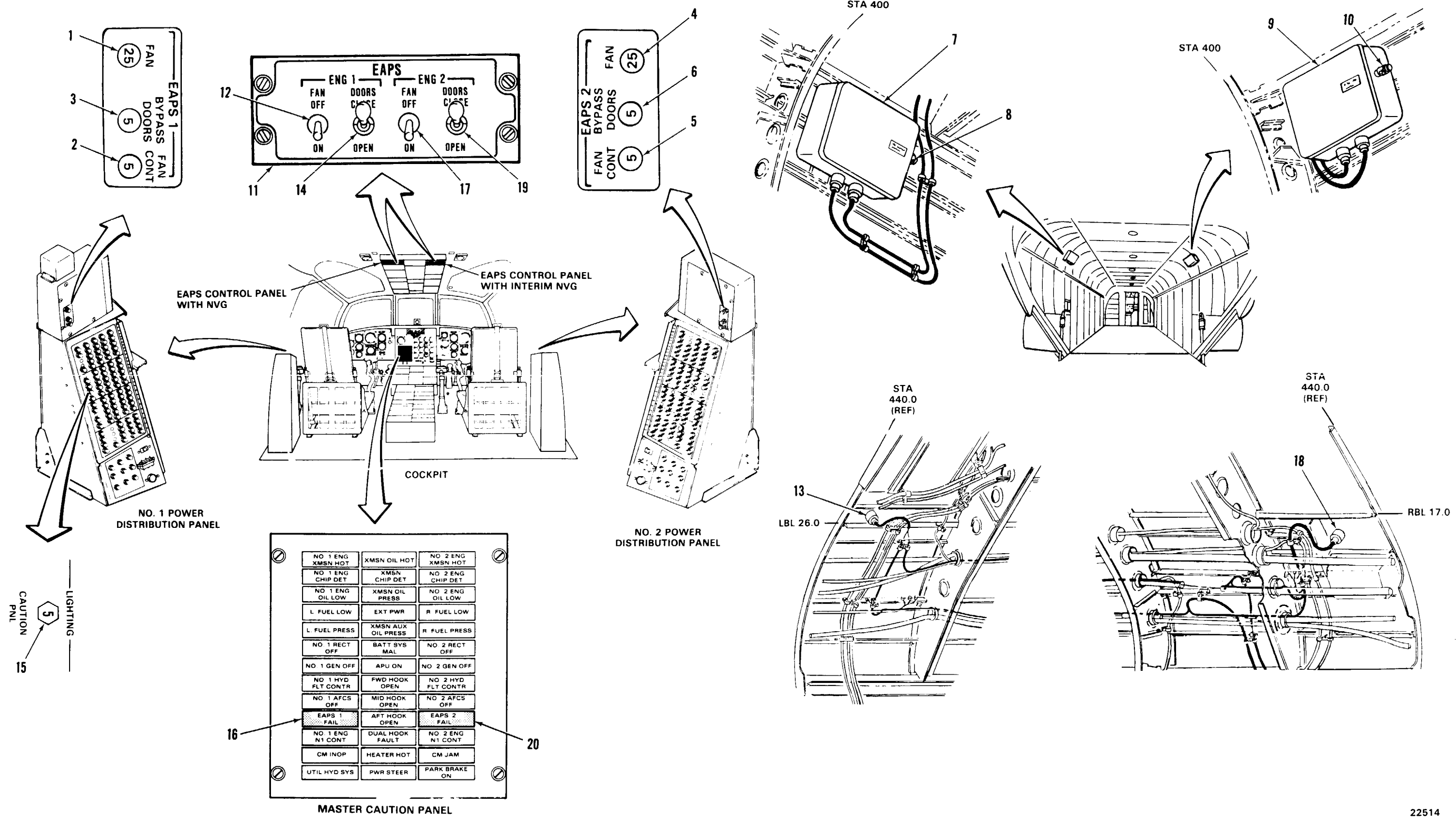

22514

16-3.5 EAPS 1 FAN, FAN CONT OR BYPASS DOORS CIRCUIT BREAKER WILL NOT STAY CLOSED

FAULT ISOLATION PROCEDURE

INITIAL SETUP

Applicable Configurations:

Helicopters with Engine Air Particle Separator Provisions

Tools:

Electrical Repairer's Tool Kit,
NSN 5180-00-323-4915
Multimeter

Materials:

None

Personnel Required:

Aircraft Electrician (2)

References:

TM 55-1520-240-23

Equipment Condition:

TM 55-1520-240-23:
Battery Disconnected
Electrical Power On
Hydraulic Power Off

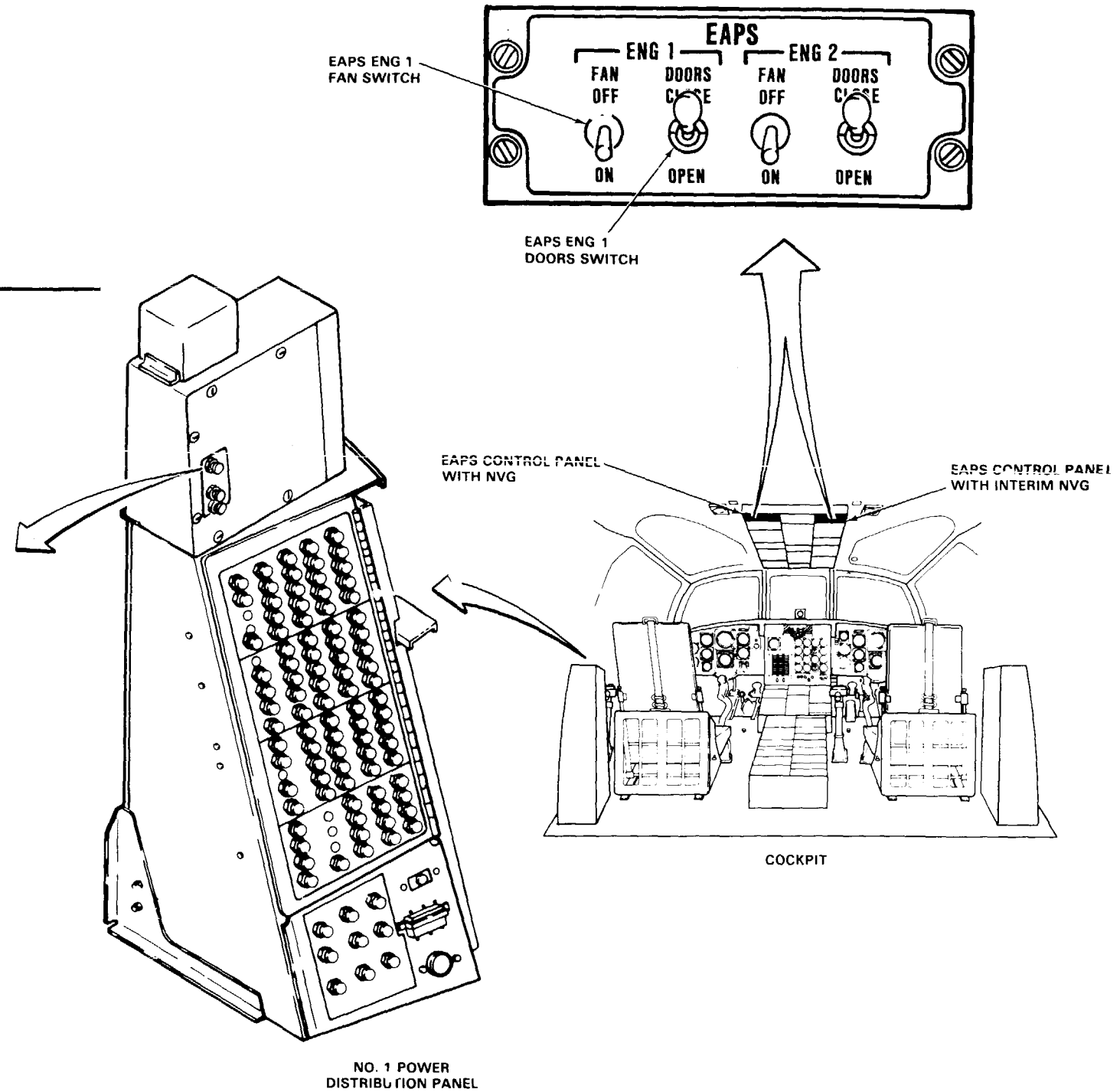
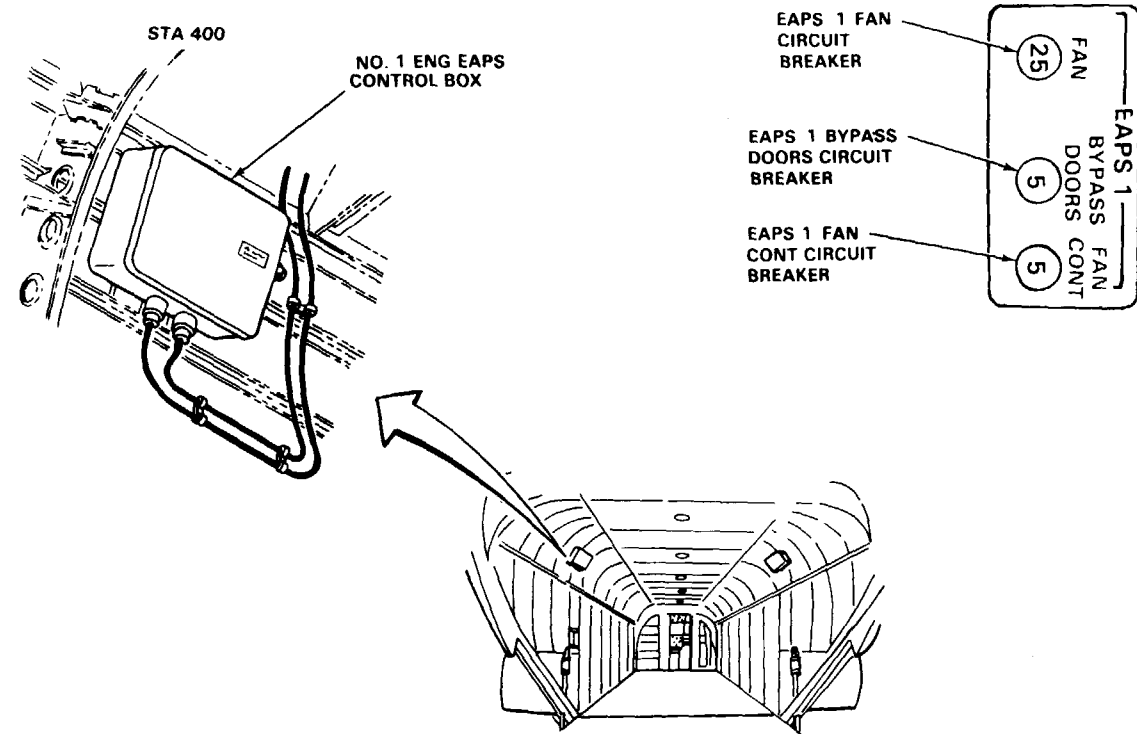

EAPS 1 FAN CB WILL NOT STAY CLOSED

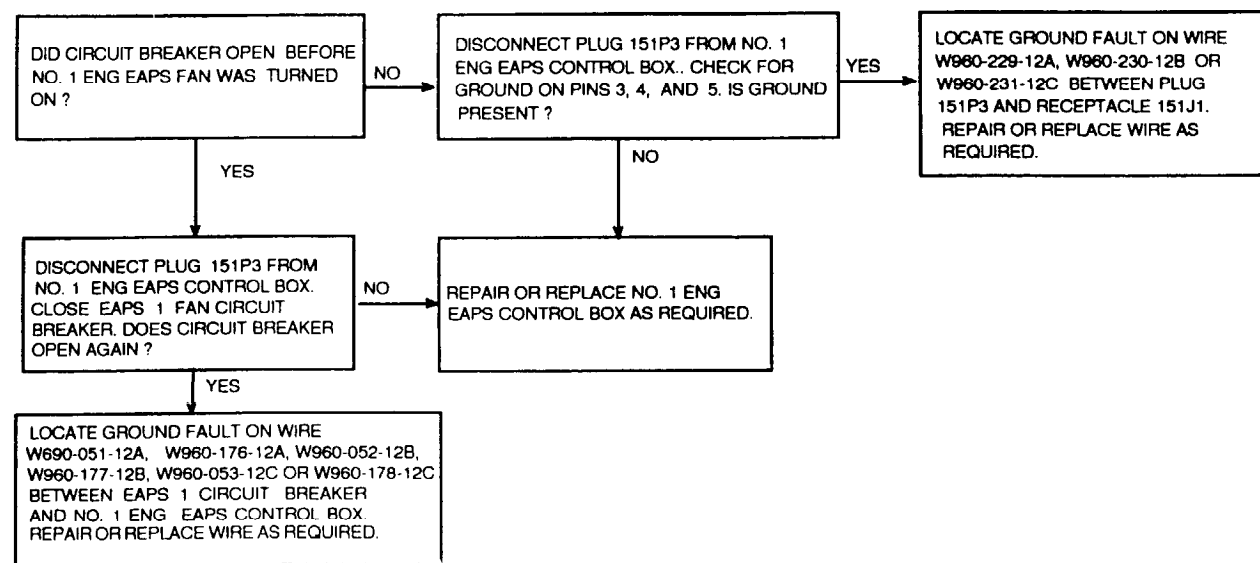

EAPS 1 BYPASS DOORS CB WILL NOT STAY CLOSED

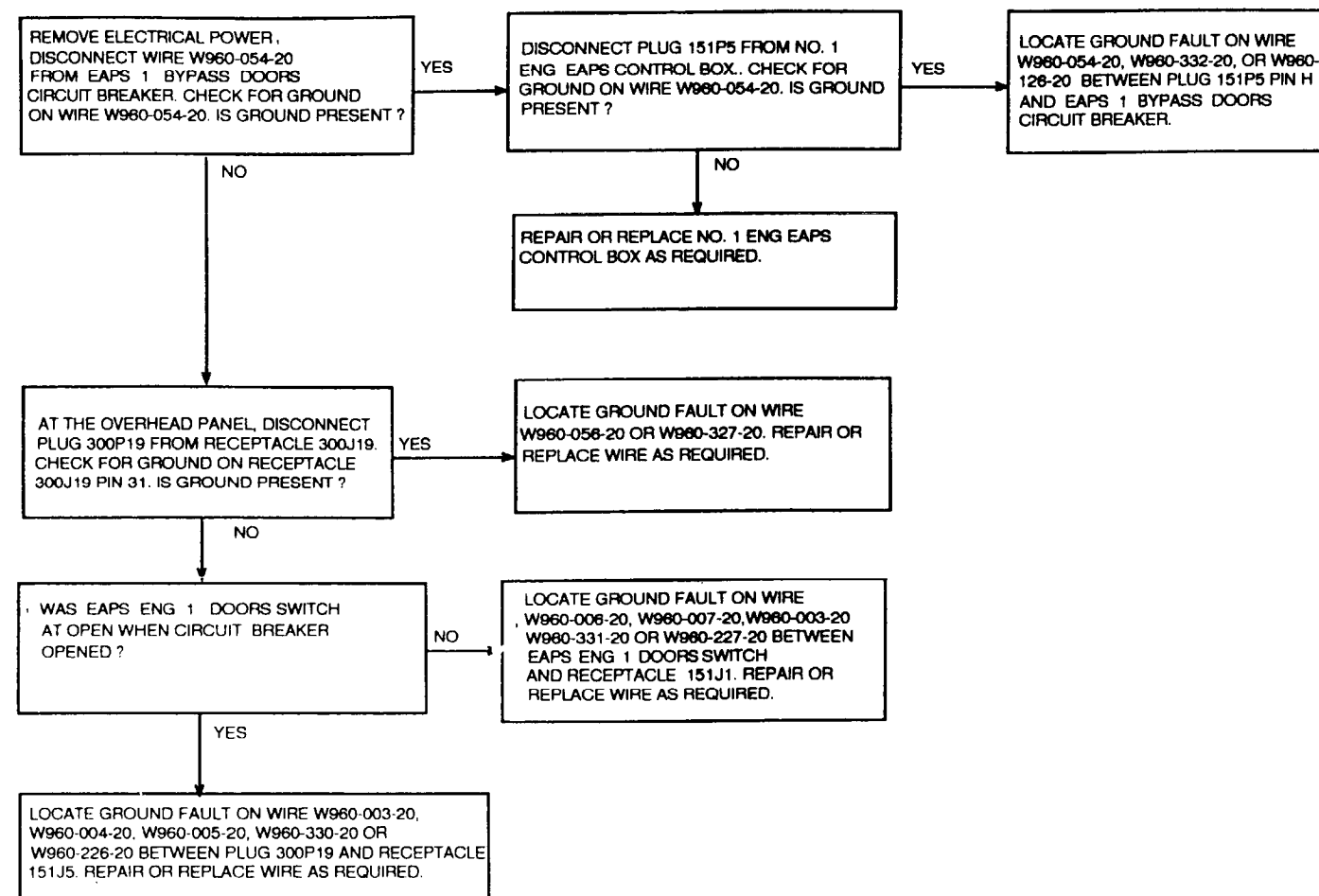

EAPS 1 FAN CONT CB WILL NOT STAY CLOSED

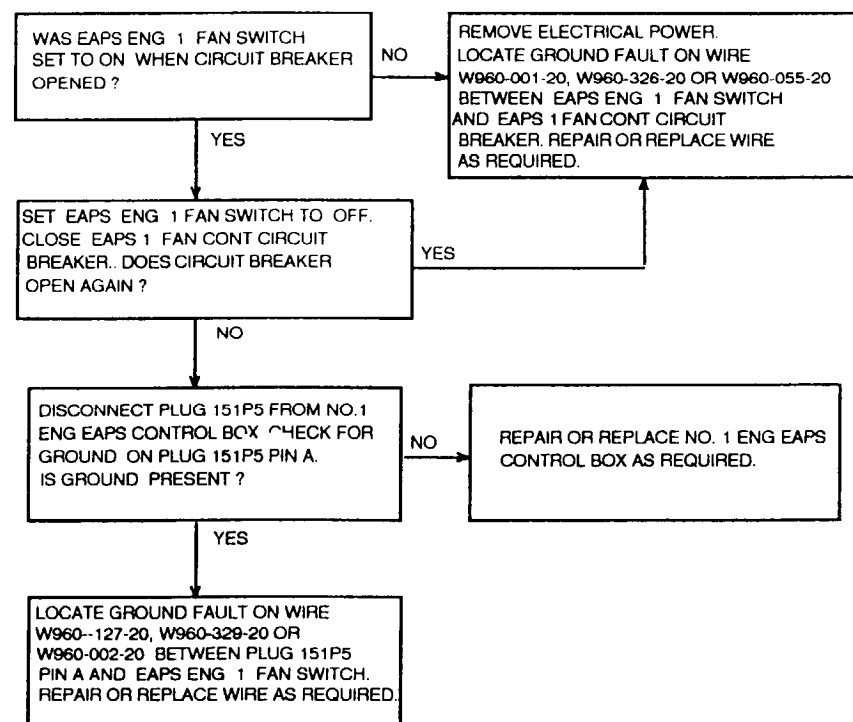

16-3.6 EAPS 2 FAN, FAN CONT OR BYPASS DOORS CIRCUIT BREAKER WILL NOT STAY CLOSED

FAULT ISOLATION PROCEDURE

INITIAL SETUP

Applicable Configurations:

Helicopters with Engine Air Particle Separator Provisions

Tools:

Electrical Repairer's Tool Kit, NSN 5180-00-323-4915
Multimeter

Materials:

None

Personnel Required:

Aircraft Electrician (2)

References:

TM 55-1520-240-23

Equipment Condition:

TM 55-1520-240-23:
Battery Disconnected
Electrical Power On
Hydraulic Power Off

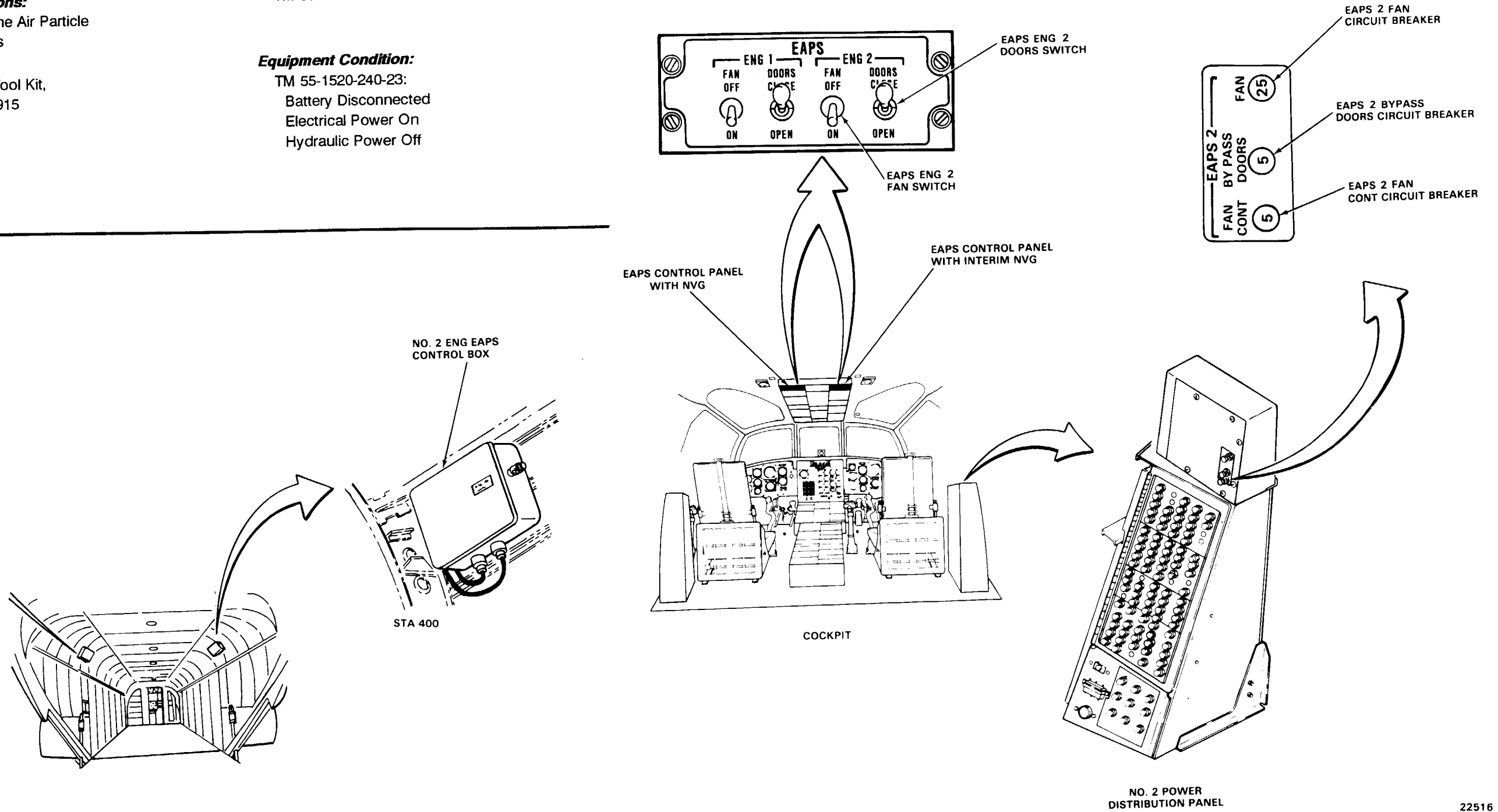

16-3.6 EAPS 2 FAN, FAN CONT OR BYPASS DOORS CIRCUIT BREAKER WILL NOT STAY CLOSED (Continued)

EAPS 2 FAN CB WILL NOT STAY CLOSED.

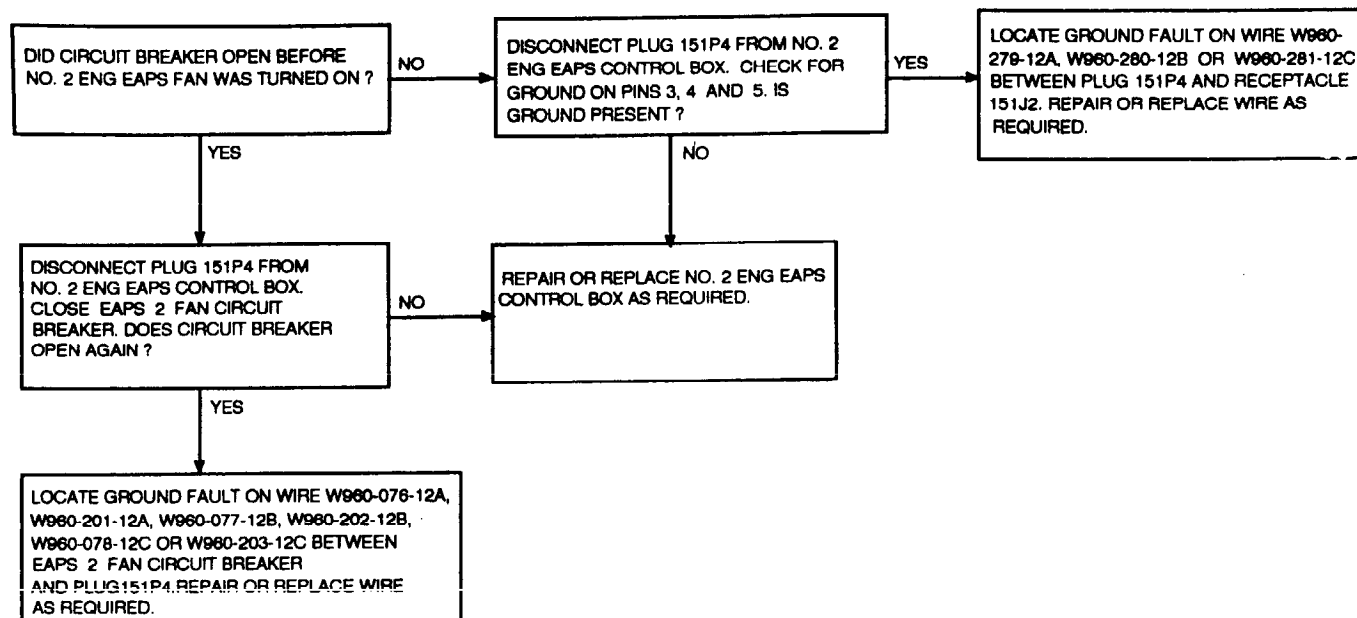

EAPS 2 FAN CONT CB WILL NOT STAY CLOSED.

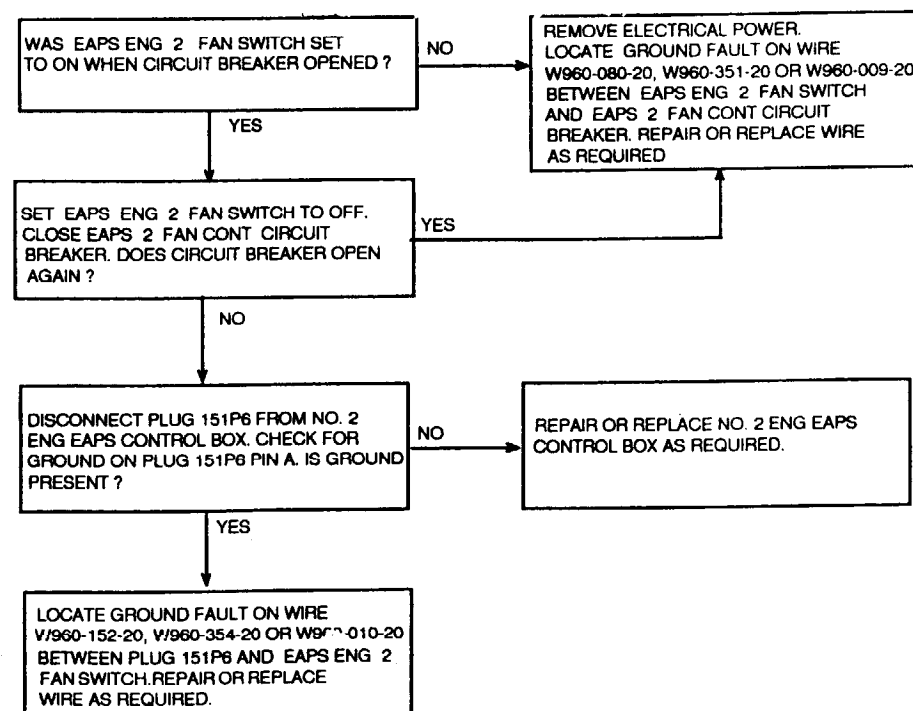

EAPS 2 BYPASS DOORS CB WILL NOT STAY CLOSED

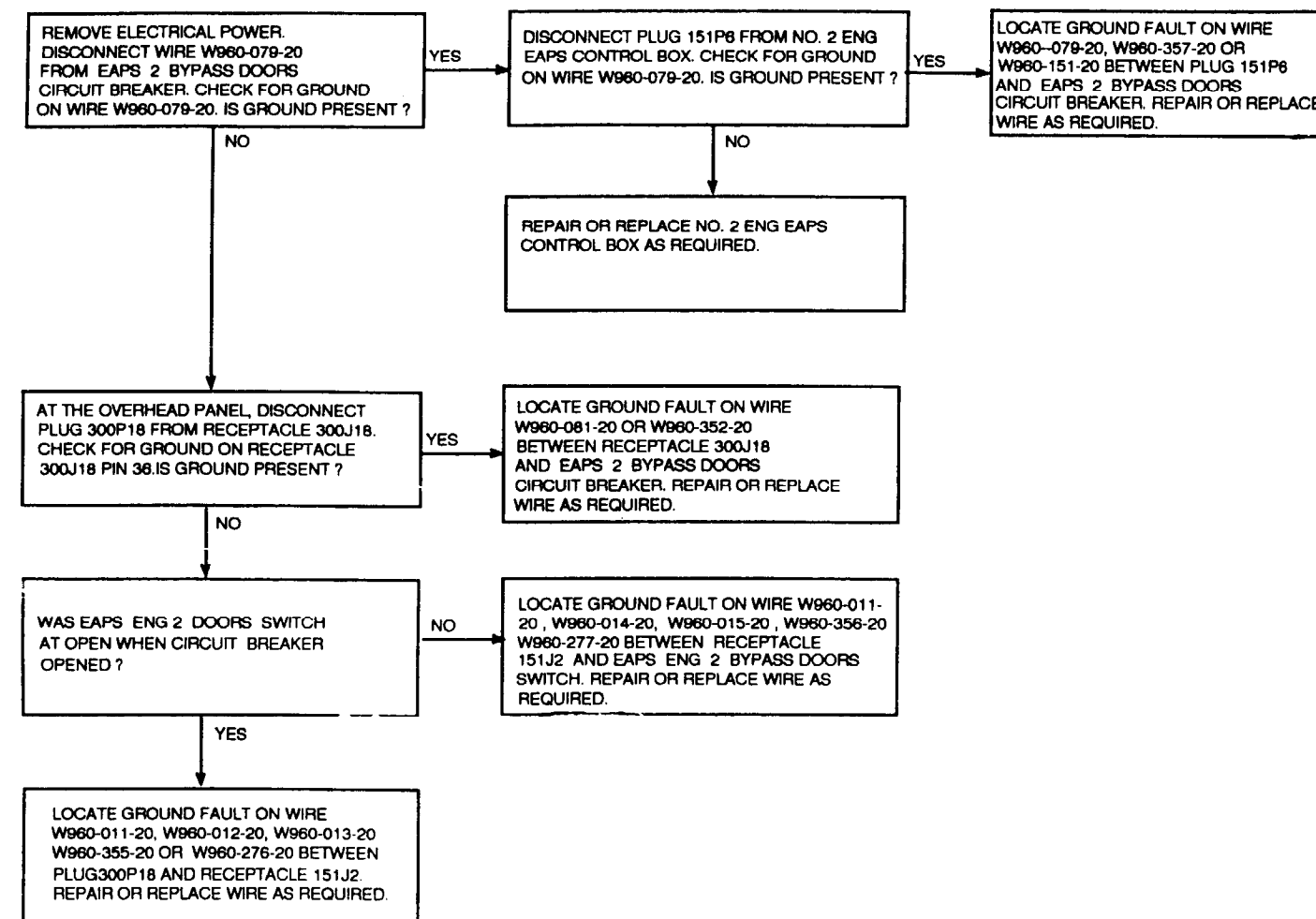

FAULT ISOLATION PROCEDURE

INITIAL SETUP

Applicable Configurations:

Helicopters with Engine Air Particle Separator Provisions

Tools:

Electrical Repairer's Tool Kit,
NSN 5180-00-323-4915
Multimeter

Materials:

None

Personnel Required:

Aircraft Electrician (2)

References:

TM 55-1520-240-23

Equipment Condition:

TM 55-1520-240-23:
Battery Connected
Electrical Power On
Hydraulic Power Off

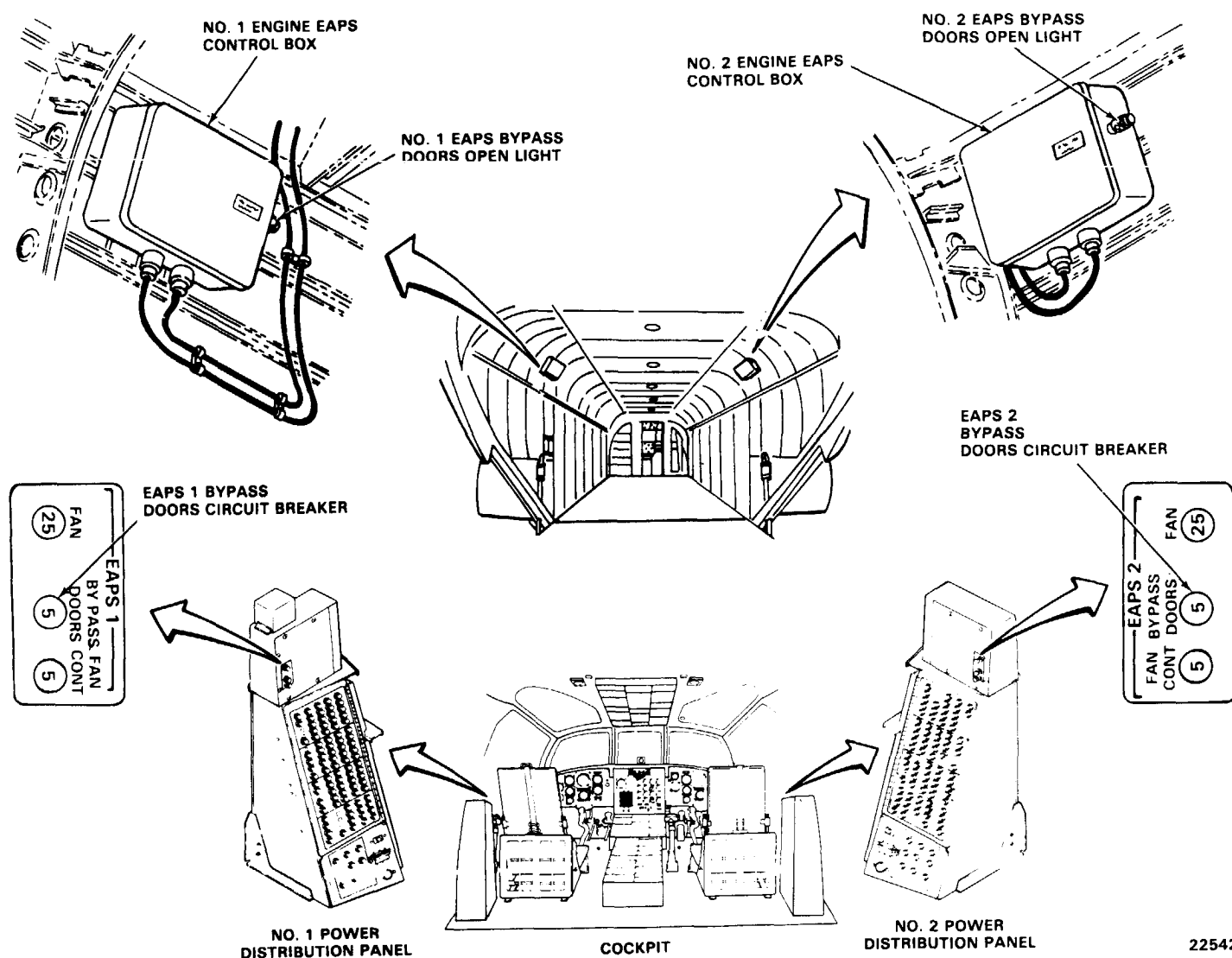

NO. 1 EAPS BYPASS DOORS OPEN LIGHT DOES NOT COME ON WHEN PRESSED TO TEST

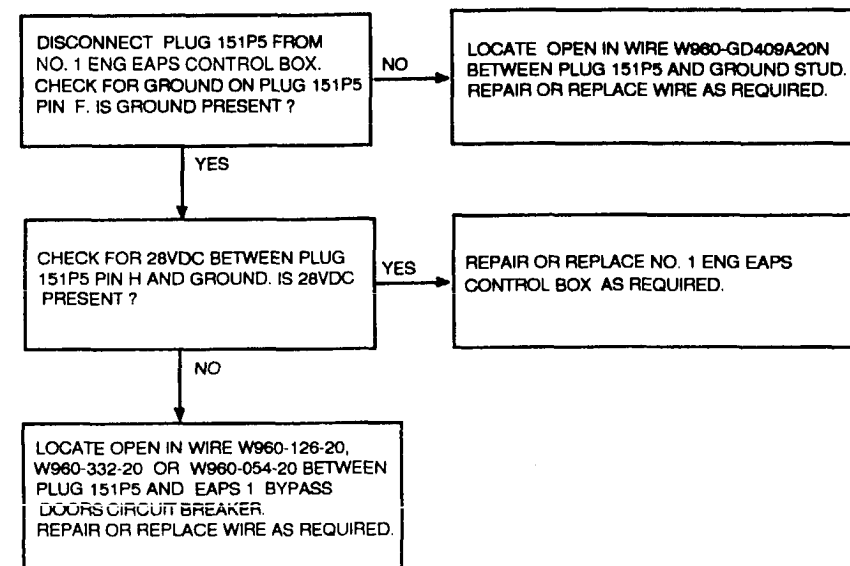

NO. 2 EAPS BYPASS DOORS OPEN LIGHT DOES NOT COME ON WHEN PRESSED TO TEST

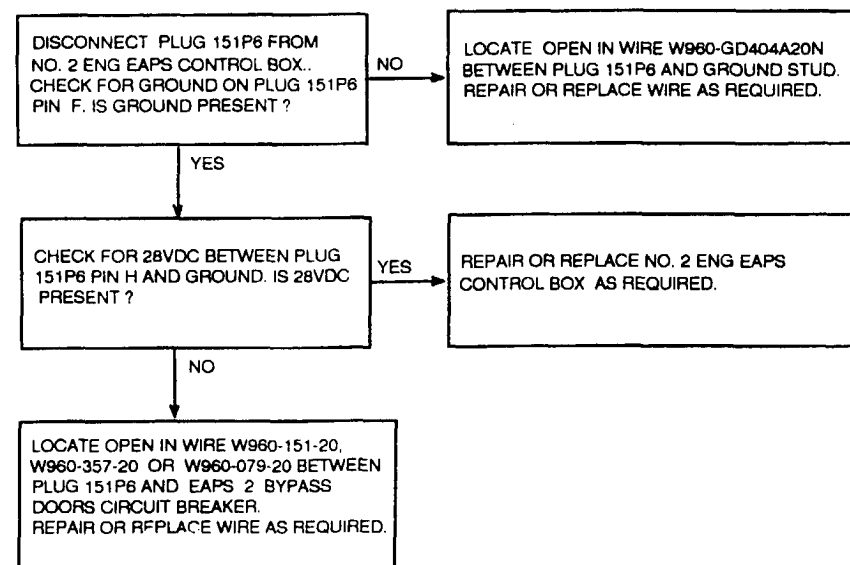

16-3.8 115 VAC IS NOT PRESENT WITH EAPS ENG 1 FAN SWITCH SET TO ON

INITIAL SETUP

Applicable Configurations:

Helicopters with Engine Air Particle Separator Provisions

Tools:

Electrical Repairer's Tool Kit,
NSN 5180-00-323-4915
Multimeter

Materials:

None

Personnel Required:

Aircraft Electrician (2)

References:

TM 55-1520-240-23

Equipment Condition:

TM 55-1520-240-23:
Battery Connected
Electrical Power On
Hydraulic Power Off

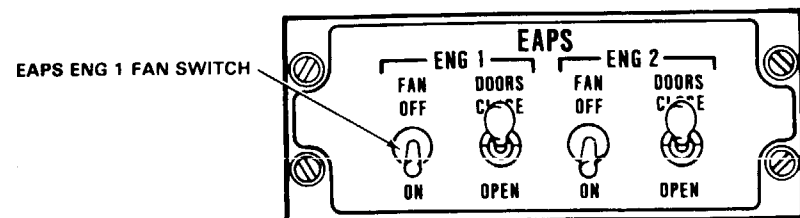
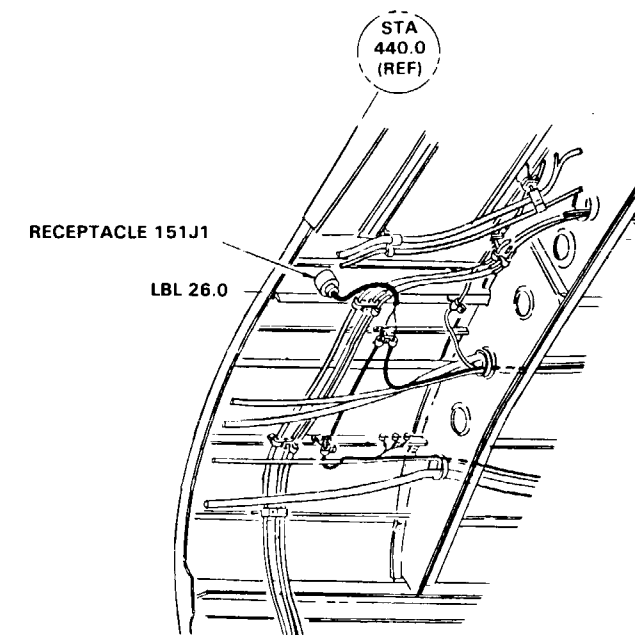

EAPS 1 FAN CIRCUIT BREAKER

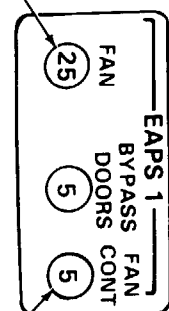

EAPS 1 FAN CONT CIRCUIT BREAKER

EAPS CONTROL PANEL WITH NVG

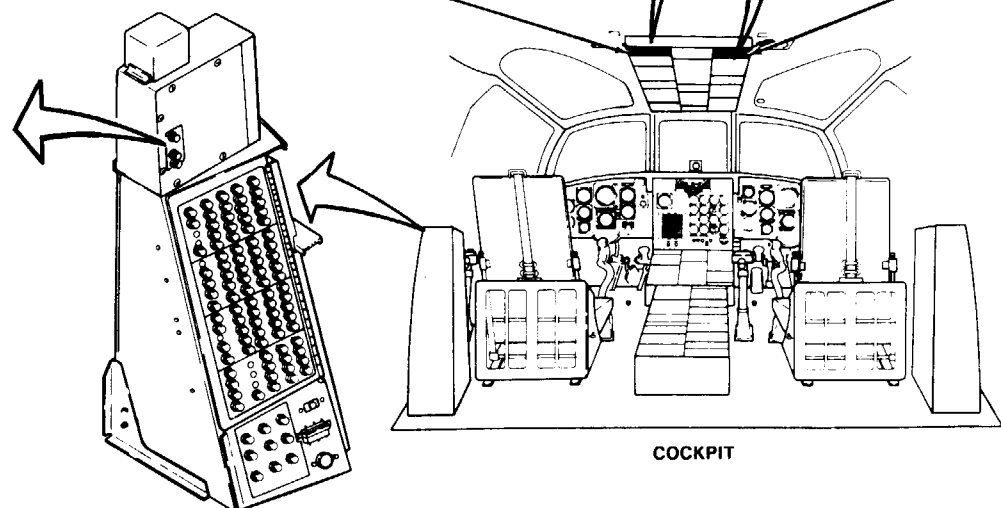

COCKPIT

EAPS CONTROL PANEL WITH INTERIM NVG

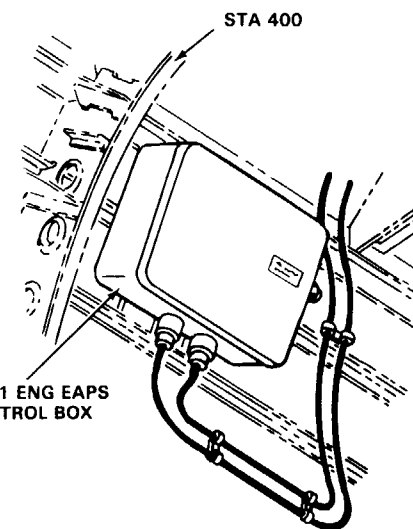

NO. 1 POWER DISTRIBUTION PANEL

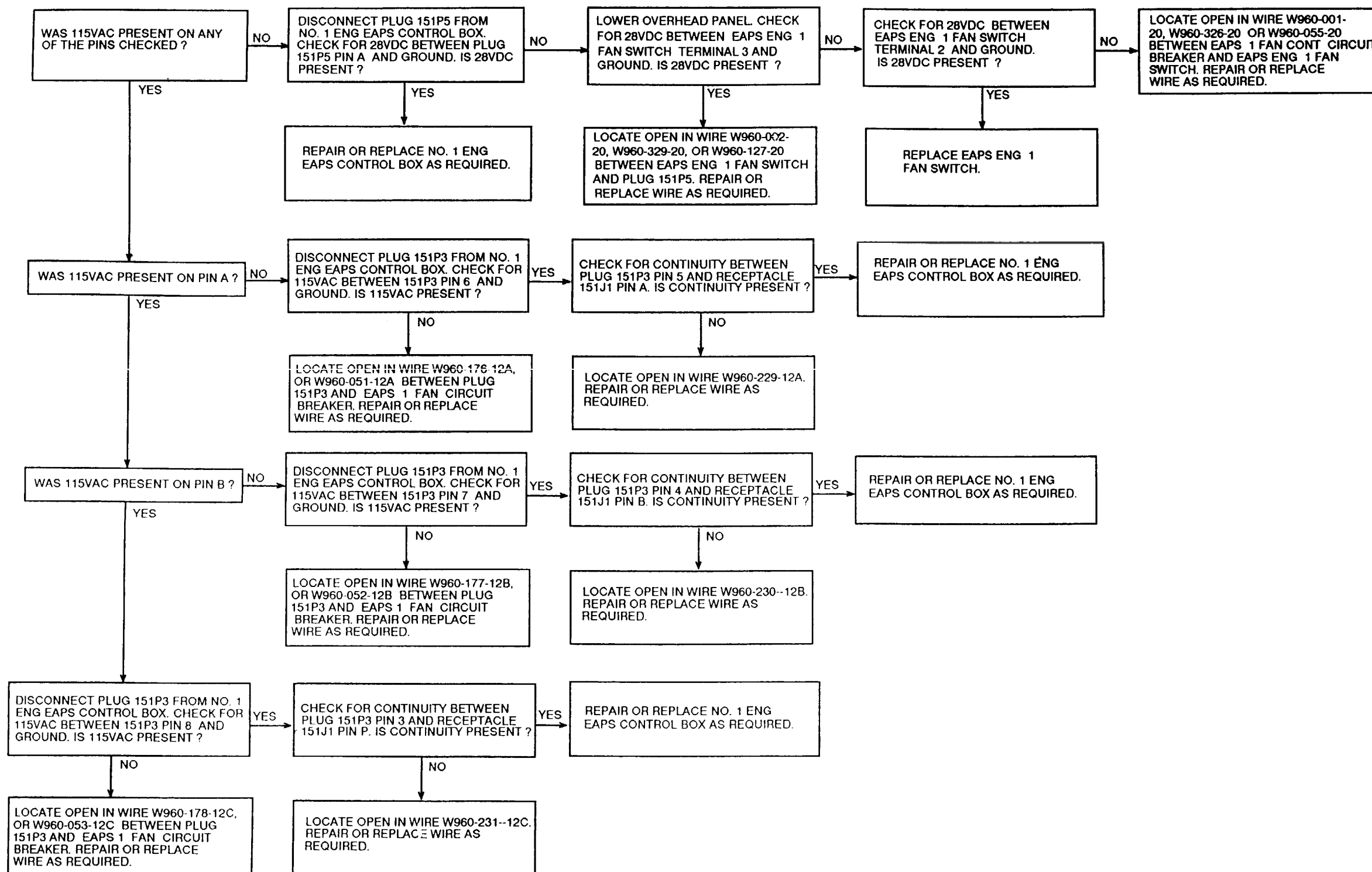

16-3.9 28 VDC IS NOT PRESENT ON RECEPTACLE 151J1 PIN U WITH EAPS ENG 1 DOORS SWITCH AT OPEN

INITIAL SETUP

Applicable Configurations:

Helicopters with Engine Air Particle Separator Provisions

Tools:

Electrical Repairer's Tool Kit,
NSN 5180-00-323-4915
Multimeter

Materials:

None

Personnel Required:

Aircraft Electrician (2)

References:

TM 55-1520 240-23

Equipment Condition:

TM 55-1520-240-23:
Battery Connected
Electrical Power On
Hydraulic Power Off

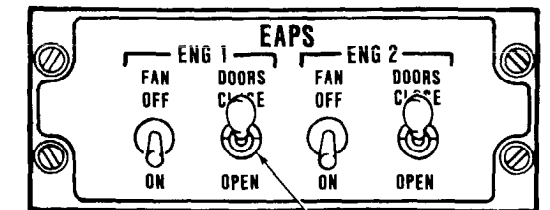
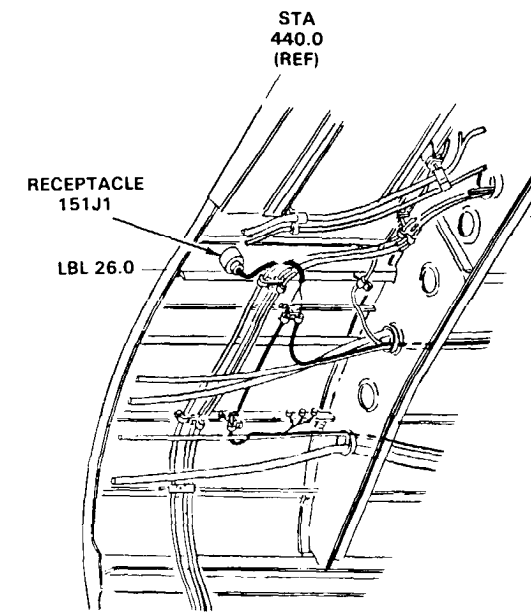

EAPS ENG 1 DOORS SWITCH

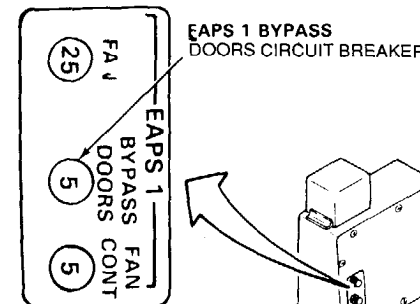
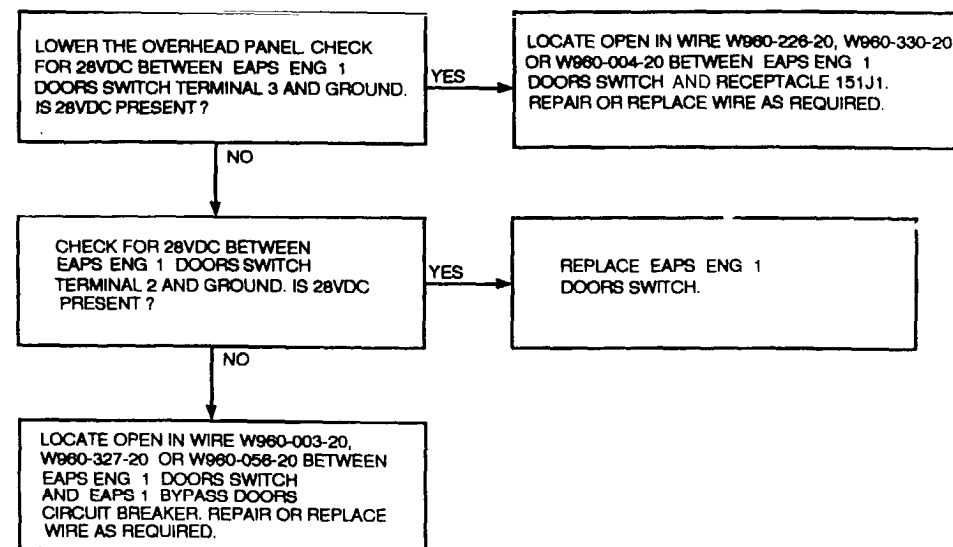

EAPS CONTROL PANEL WITH NVG

EAPS CONTROL PANEL WITH INTERIM NVG

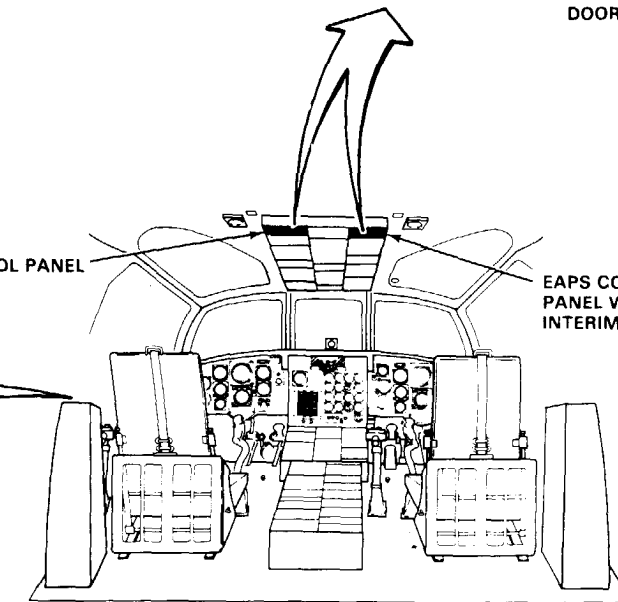

NO. 1 POWER DISTRIBUTION PANEL

22540

INITIAL SETUP

Applicable Configurations:

Helicopters with Engine Air Particle Separator Provisions

Tools:

Electrical Repairer's Tool Kit,
NSN 5180-00-323-4915
Multimeter

Materials:

None

Personnel Required:

Aircraft Electrician (2)

References:

TM 55-1520-240-23

Equipment Condition:

TM 55-1520-240-23:
Battery Connected
Electrical Power Off
Hydraulic Power Off

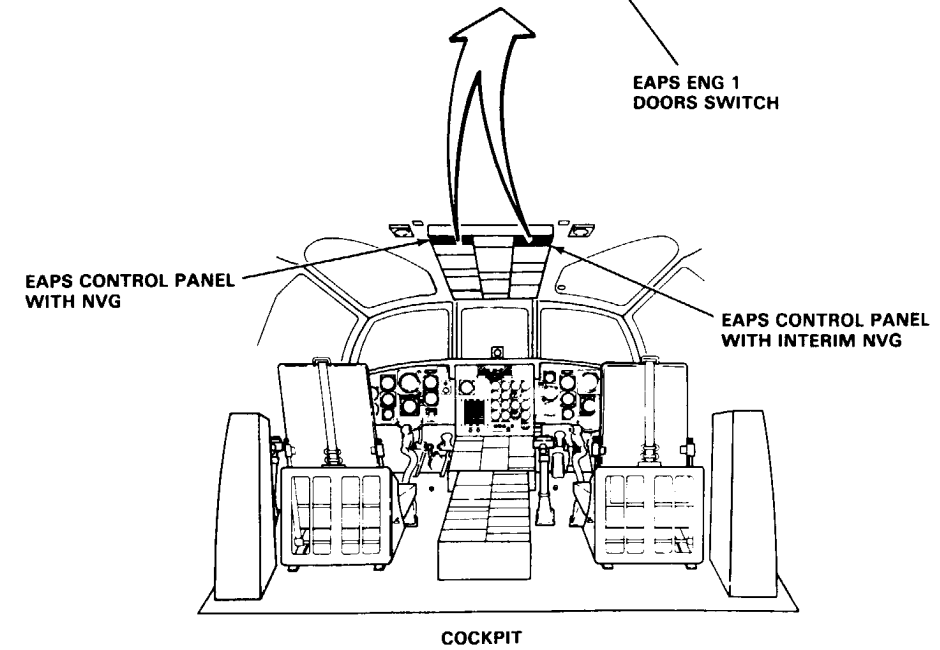
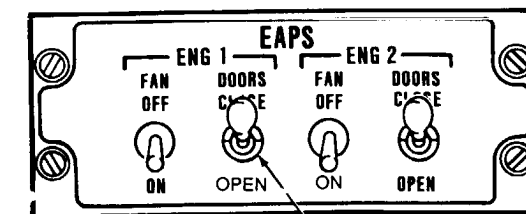
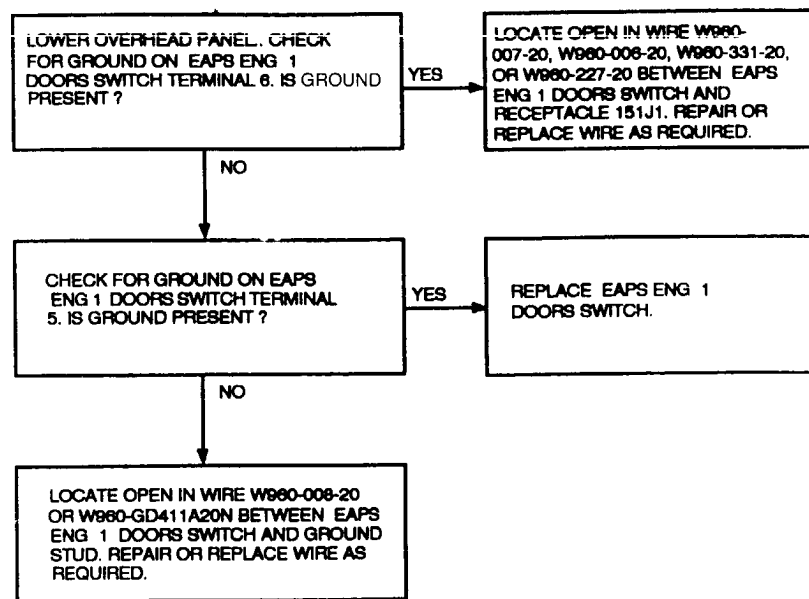
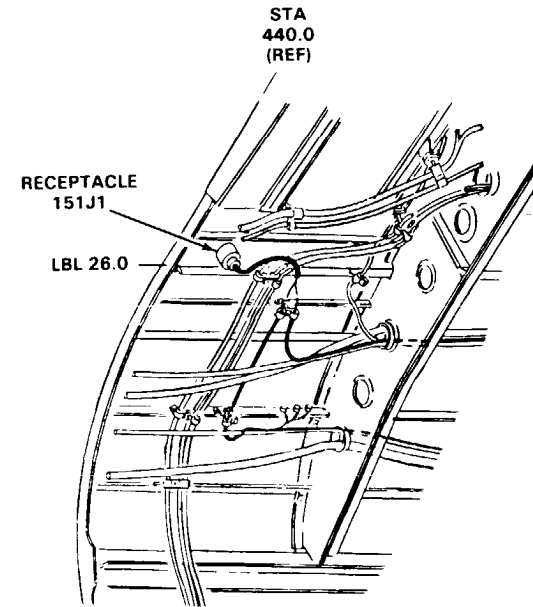

16-3.11 28 VDC IS NOT PRESENT ON RECEPTACLE 151J1 PIN a WITH EAPS ENG 1 DOORS SWITCH AT CLOSE

INITIAL SETUP

Applicable Configurations:

Helicopters with Engine Air Particle Separator Provisions

Tools:

Electrical Repairer's Tool Kit,
NSN 5180-00-323-4915
Multimeter

Materials:

None

Personnel Required:

Aircraft Electrician (2)

References:

TM 55-1520-240-23

Equipment Condition:

TM 55-1520-240-23:
Battery Connected
Electrical Power On
Hydraulic Power Off

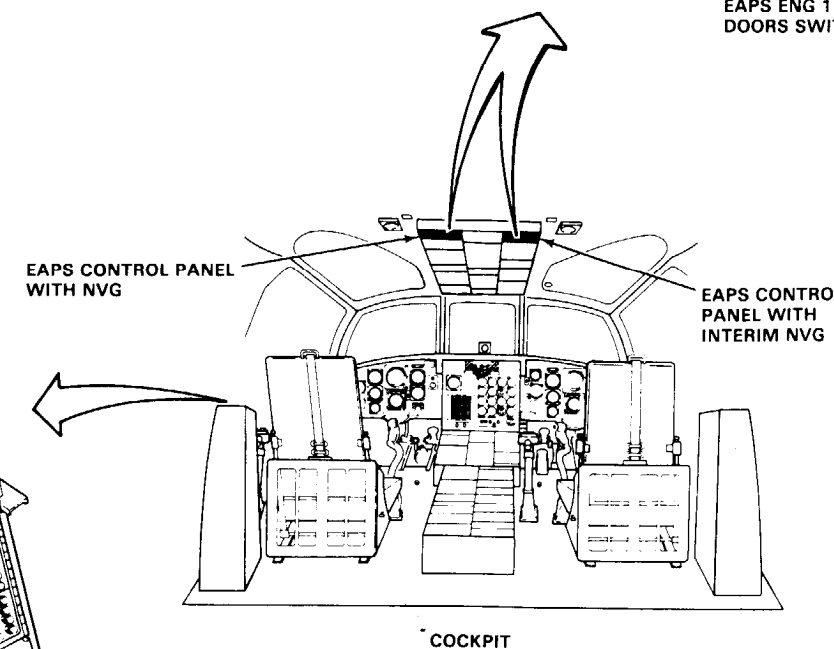
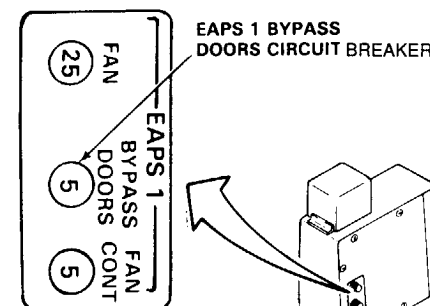
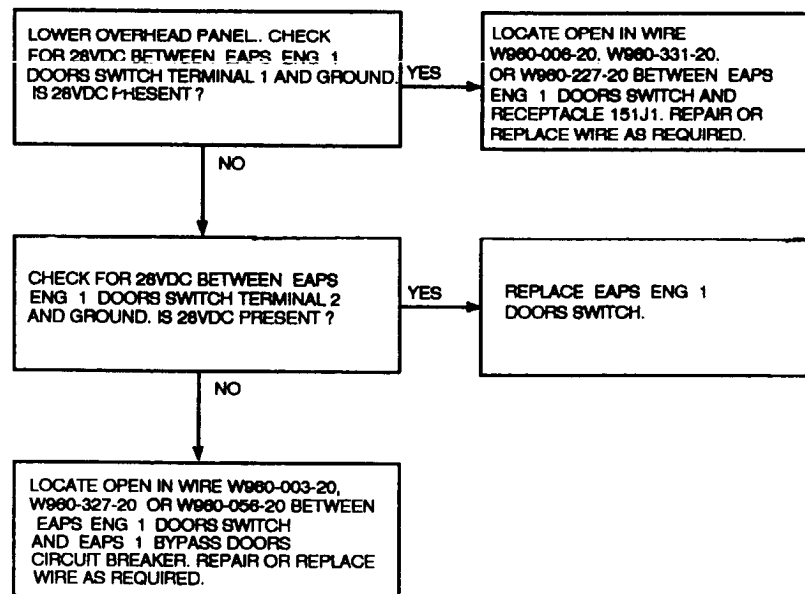
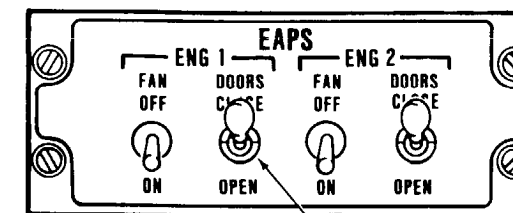
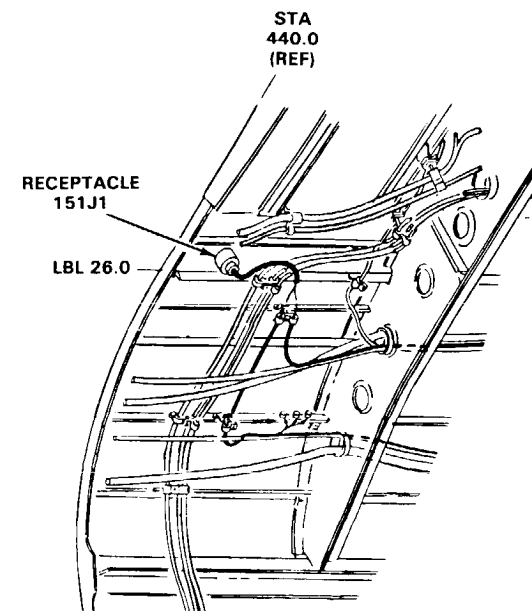

NO. 1 POWER DISTRIBUTION PANEL

16-3.12 GROUND IS NOT PRESENT ON RECEPTACLE 151J1 PIN U WITH EAPS ENG 1 DOORS SWITCH AT CLOSE

INITIAL SETUP

Applicable Configurations:

Helicopters with Engine Air Particle Separator Provisions

Tools:

Electrical Repairer's Tool Kit,
NSN 5180-00-323-4915
Multimeter

Materials:

None

Personnel Required:

Aircraft Electrician (2)

References:

TM 55-1520-240-23

Equipment Condition:

TM 55-1520-240-23:
Battery Connected
Electrical Power Off
Hydraulic Power Off

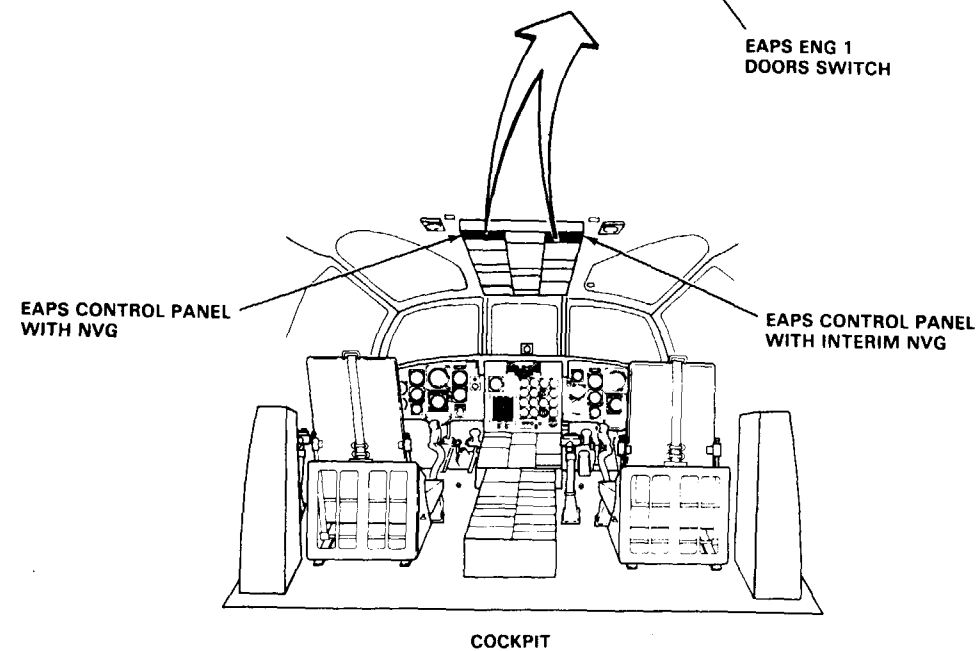
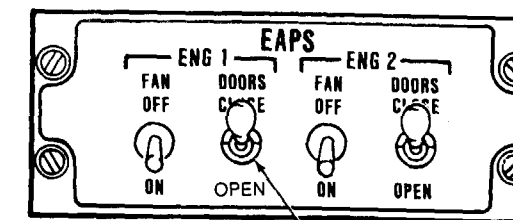
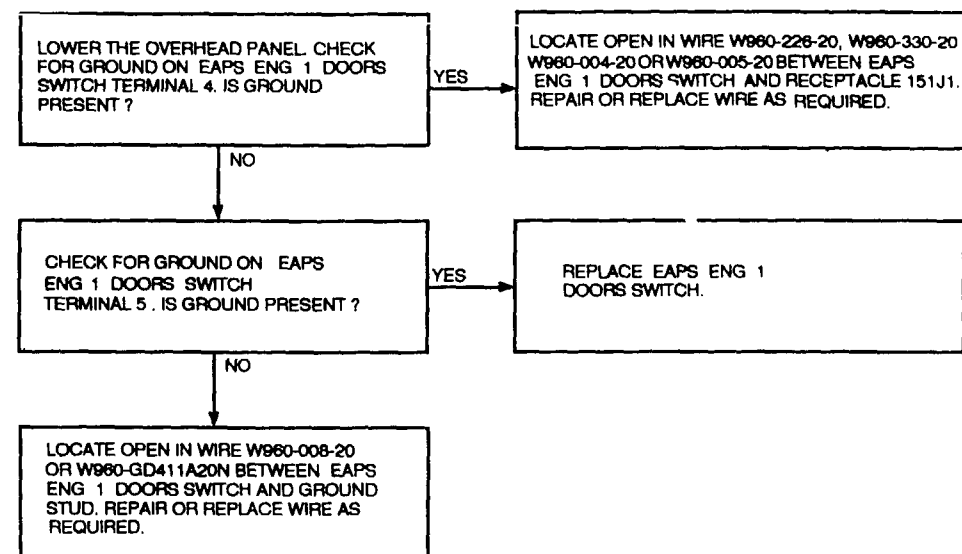
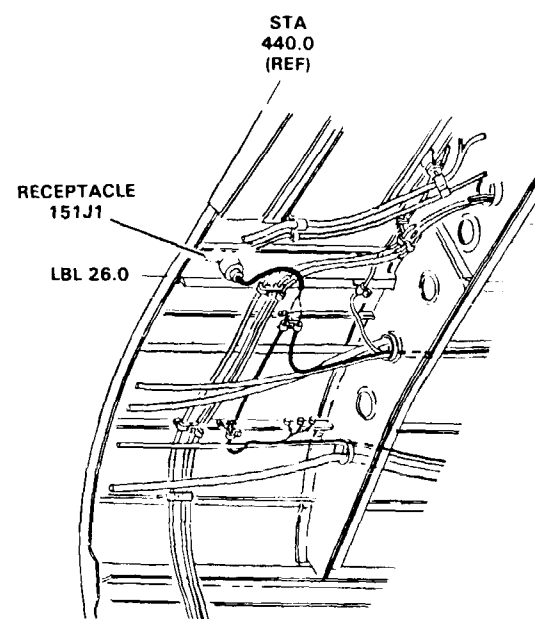

16-3.13 EAPS 1 FAIL CAPSULE DOES NOT COME ON

16-3.13

INITIAL SETUP

Applicable Configurations:

Helicopters with Engine Air Particle Separator Provisions

Tools:

Electrical Repairer's Tool Kit,
NSN 5180-00-323-4915
Multimeter

Materials:

None

Personnel Required:

Aircraft Electrician (2)

References:

TM 55-1520-240-23

Equipment Condition:

TM 55-1520-240-23:
Battery Connected
Electrical Power On
Hydraulic Power Off

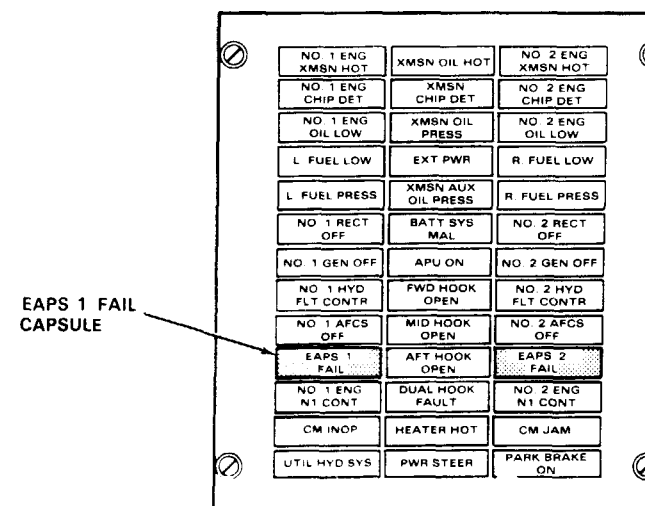
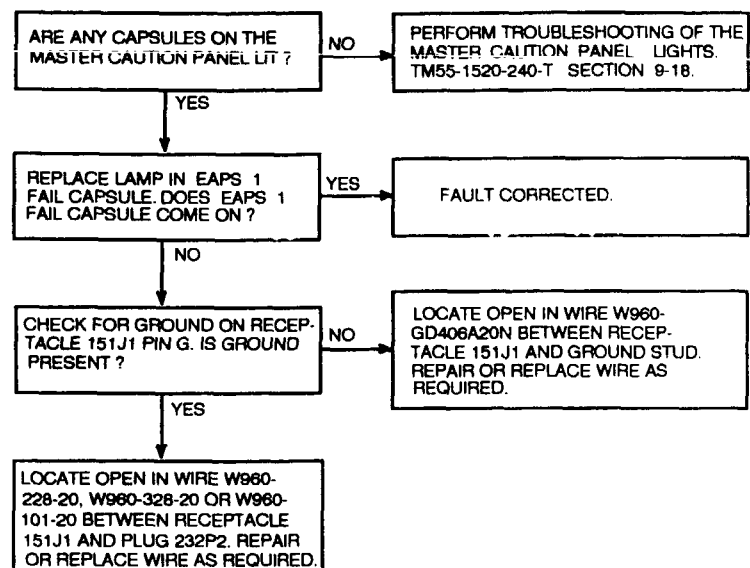
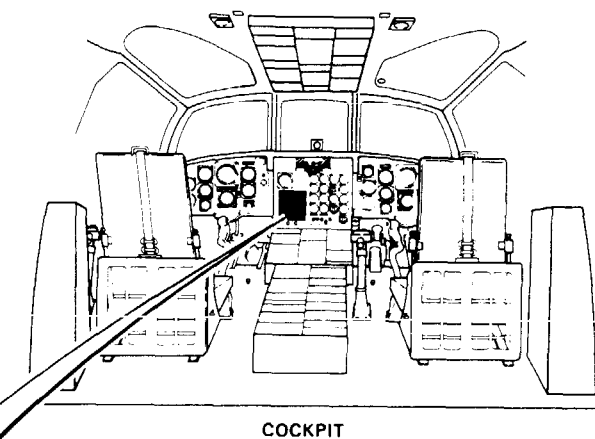
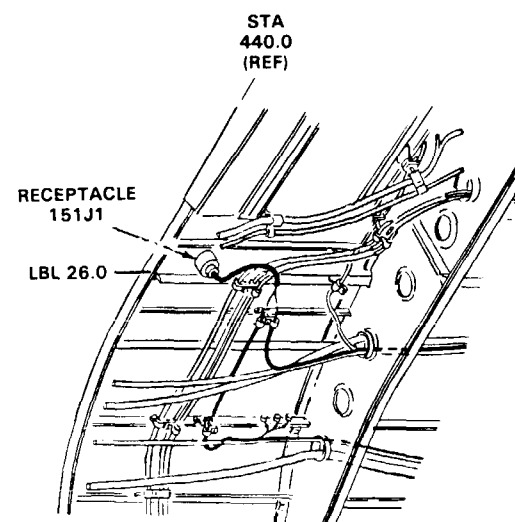

22536

16-3.14 115 VAC IS NOT PRESENT WITH EAPS ENG 2 FAN SWITCH SET TO ON

INITIAL SETUP

Applicable Configurations:

Helicopters with Engine Air Particle Separator Provisions

Tools:

Electrical Repairer's Tool Kit,
NSN 5180-00-323-4915
ultimeter

Materials:

None

Personnel Required:

Aircraft Electrician (2)

References:

TM 55-1520-240-23

Equipment Condition:

TM 55-1520-240-23:
Battery Connected
Electrical Power On
Hydraulic Power Off

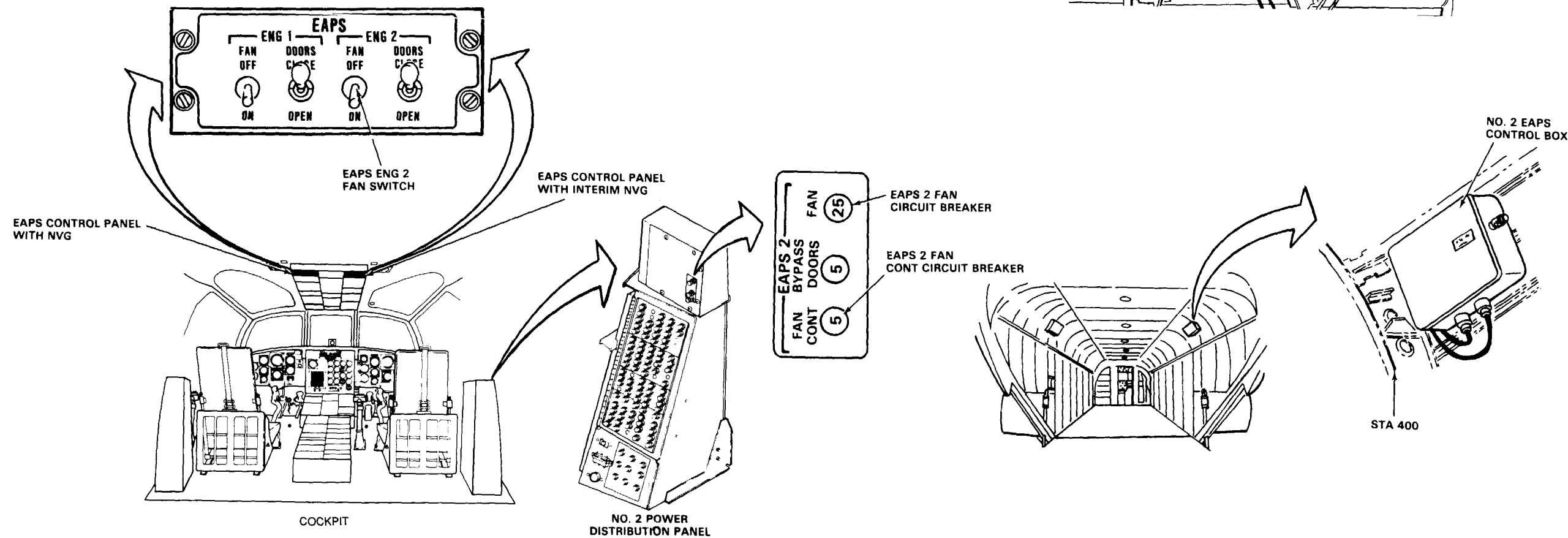
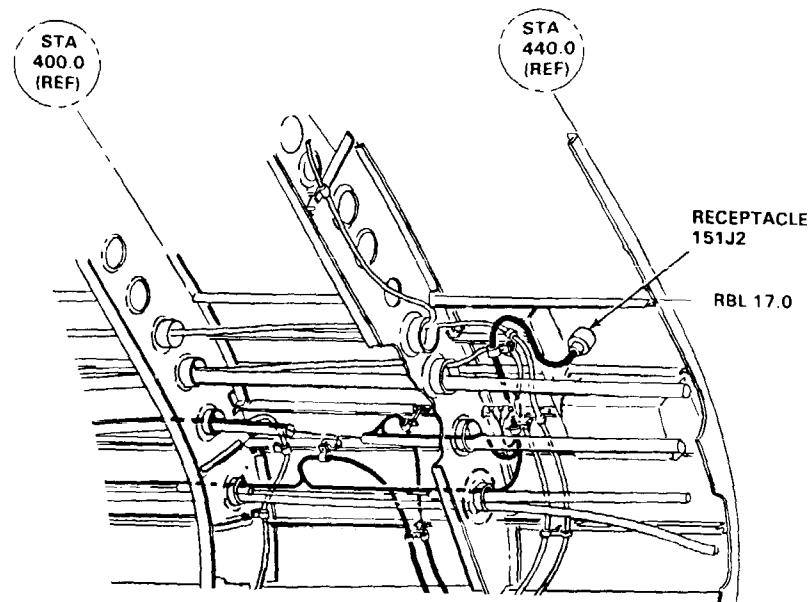

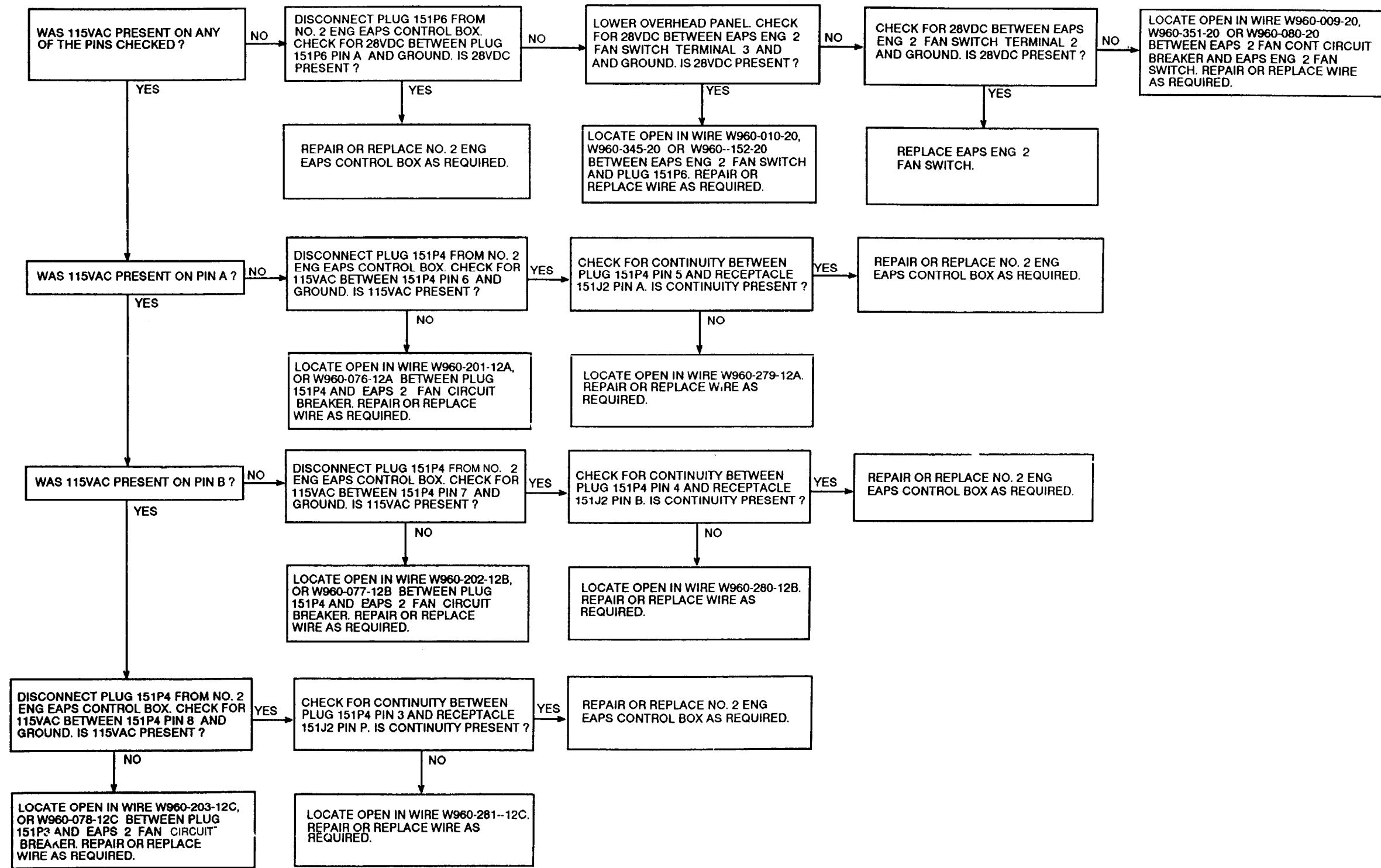

INITIAL SETUP

Applicable Configurations:

Helicopters with Engine Air Particle Separator Provisions

Tools:

Electrical Repairer's Tool Kit,
NSN 5180-00-323-4915
Multimeter

Materials:

None

Personnel Required:

Aircraft Electrician (2)

References:
TM 55-1520-240-23

Equipment Condition:
TM 55-1520-240-23:

Battery Connected
Electrical Power On
Hydraulic Power Off

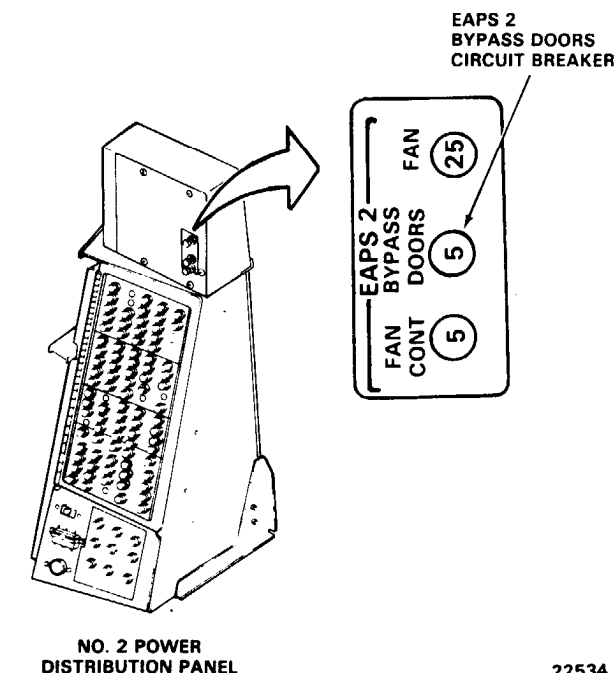
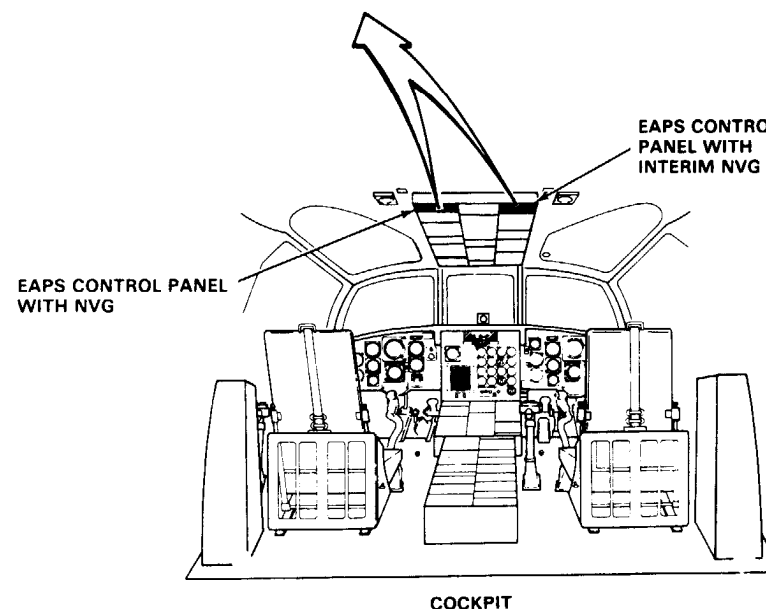
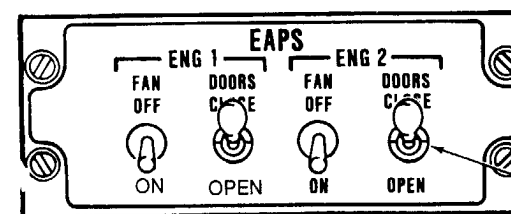
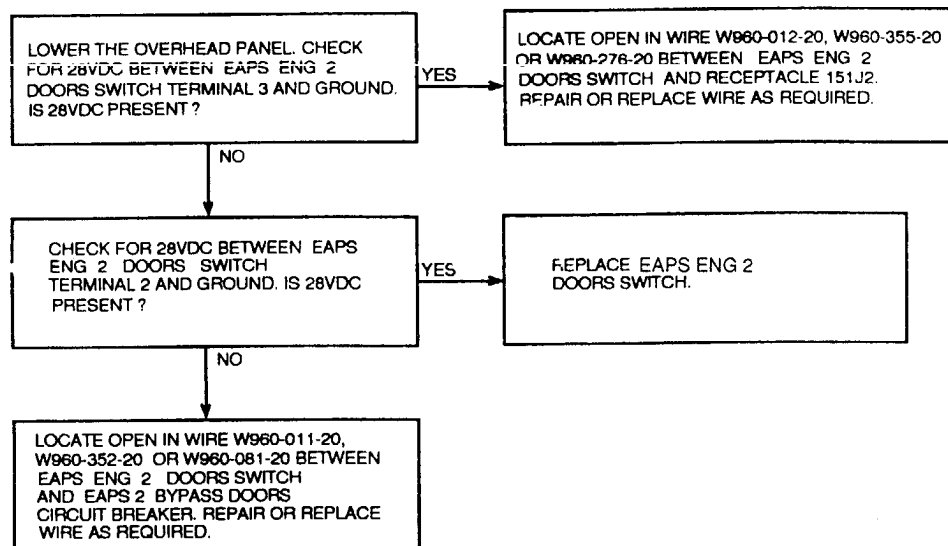
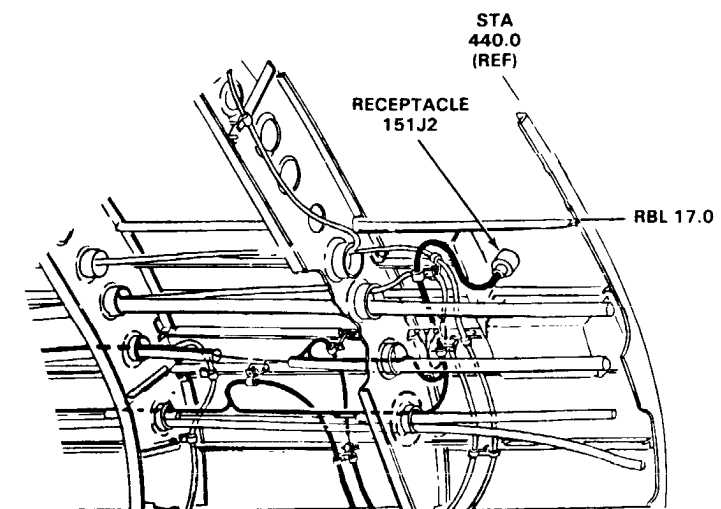

INITIAL SETUP

Applicable Configurations:

Helicopters with Engine Air Particle Separator Provisions

Tools:

Electrical Repairer's Tool Kit,
NSN 5180-00-323-4915
Multimeter

Materials:

None

Personnel Required:

Aircraft Electrician (2)

References:

TM 55-1520-240-23

Equipment Condition:

TM 55-1520-240-23:
Battery Connected
Electrical Power On
Hydraulic Power Off

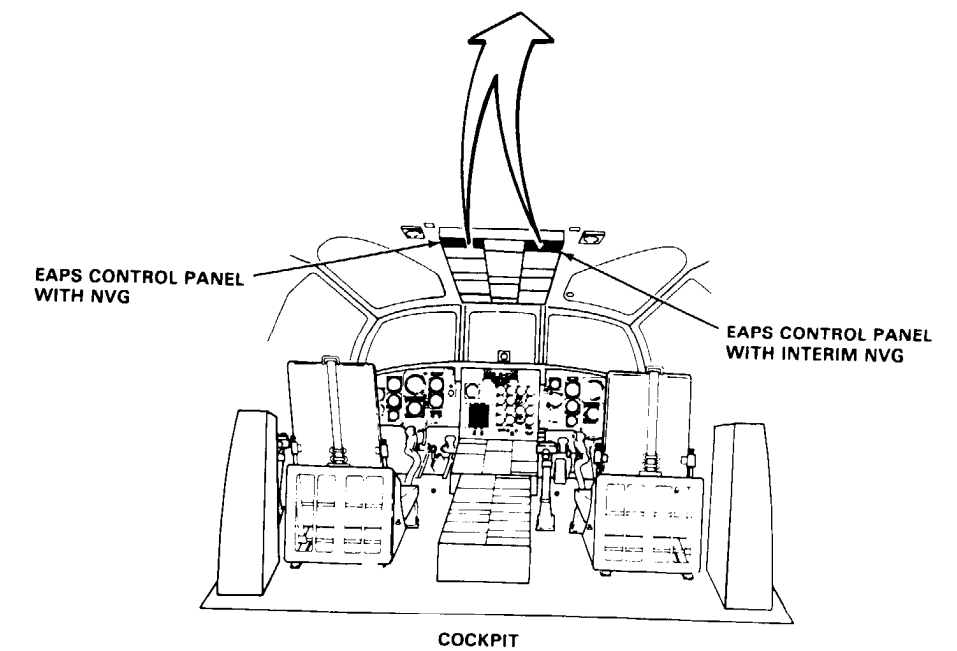
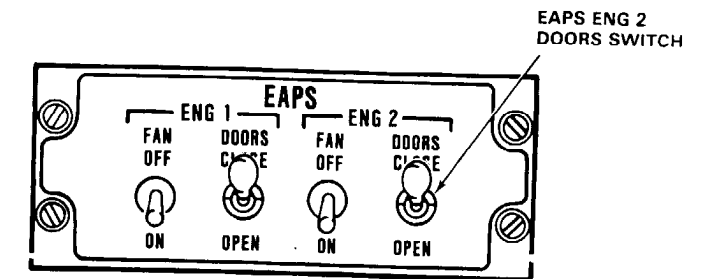
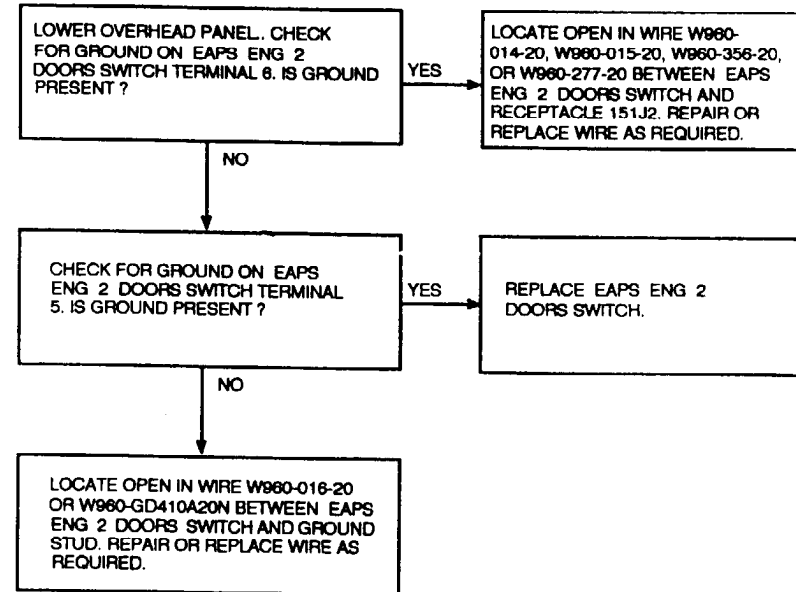
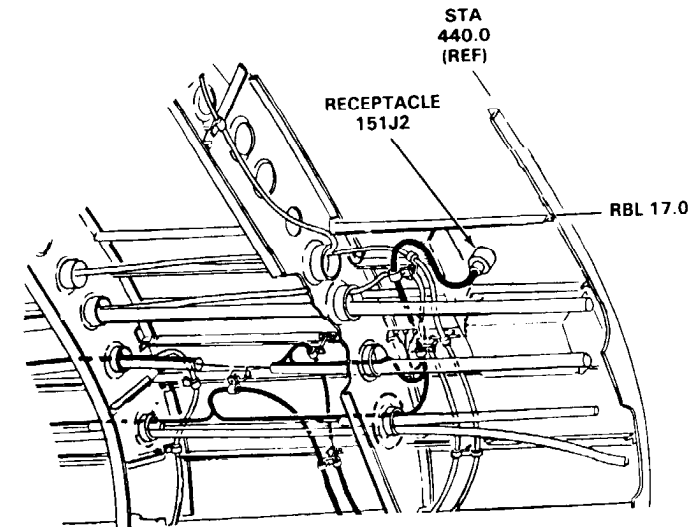

22544

INITIAL SETUP

Applicable Configurations:

Helicopters with Engine Air Particle Separator Provisions

Tools:

Electrical Repairer's Tool Kit,
NSN 5180-00-323-4915
Multimeter

Materials:

None

Personnel Required:

Aircraft Electrician (2)

References:

TM 55-1520-240-23

Equipment Condition:

TM 55-1520-240-23:
Battery Connected
Electrical Power On
Hydraulic Power Off

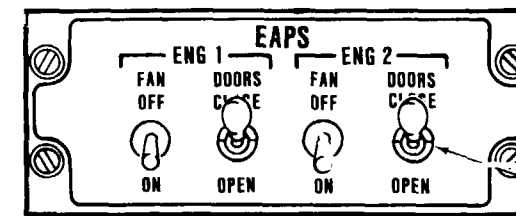
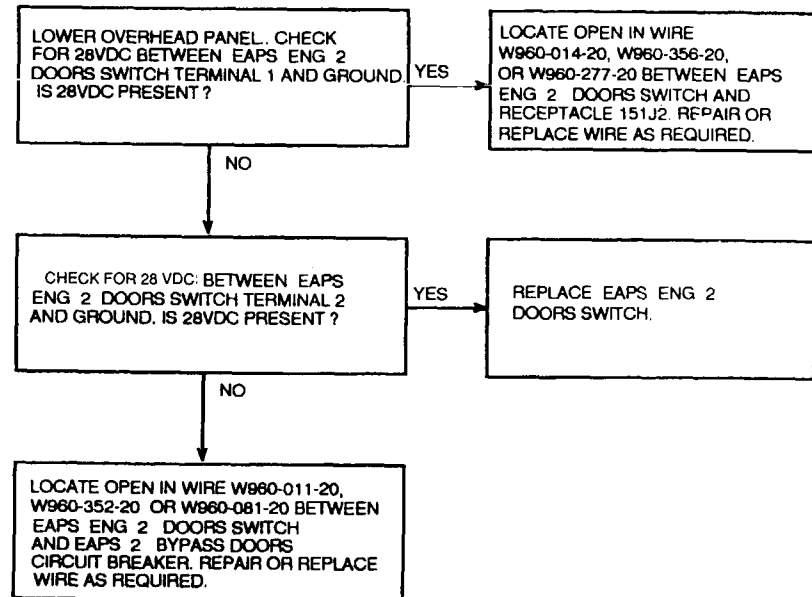
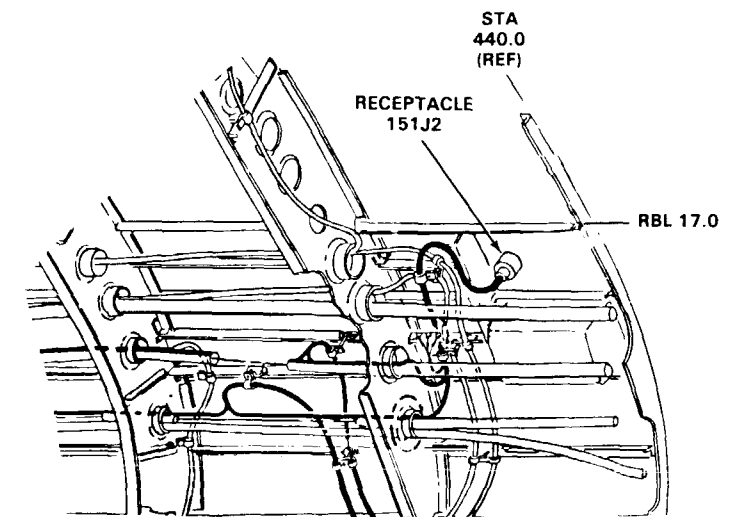

EAPS ENG 2 DOORS SWITCH

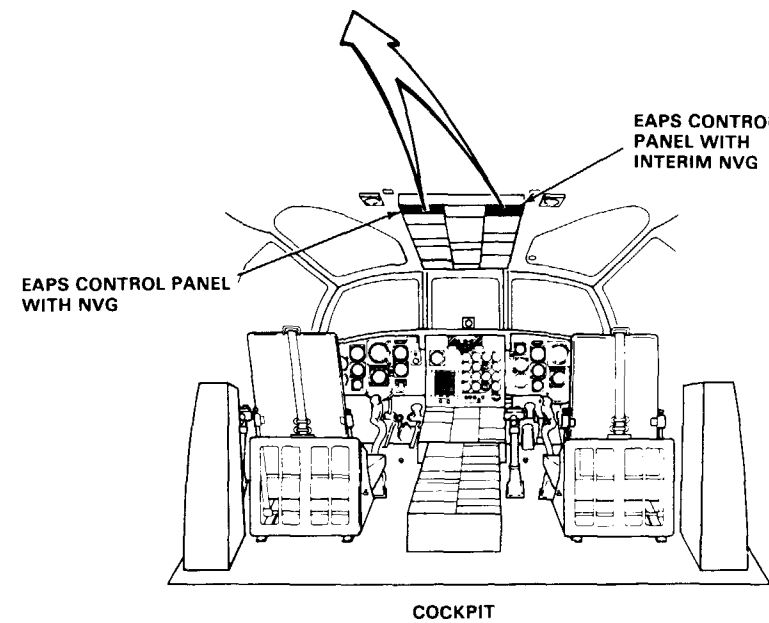

EAPS CONTROL PANEL WITH NVG

EAPS CONTROL PANEL WITH INTERIM NVG

COCKPIT

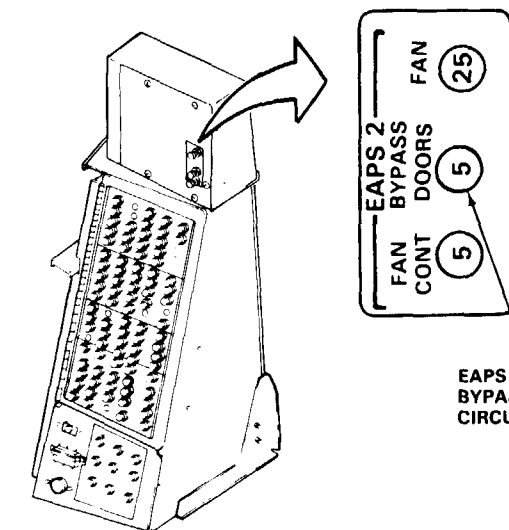

NO. 2 POWER DISTRIBUTION PANEL

EAPS 2 BYPASS DOORS CIRCUIT BREAKER

16-3.18 GROUND IS NOT PRESENT ON RECEPTACLE 151J2 PIN U WITH EAPS ENG 2 DOORS SWITCH AT CLOSE

INITIAL SETUP

Applicable Configurations:

Helicopters with Engine Air Particle Separator Provisions

Tools:

Electrical Repairer's Tool Kit,
NSN 5180-00-323-4915
Multimeter

Materials:

None

Personnel Required:

Aircraft Electrician (2)

References:

TM 55-1520-240-23

Equipment Condition:

TM 55-1520-240-23:
Battery Connected
Electrical Power On
Hydraulic Power Off

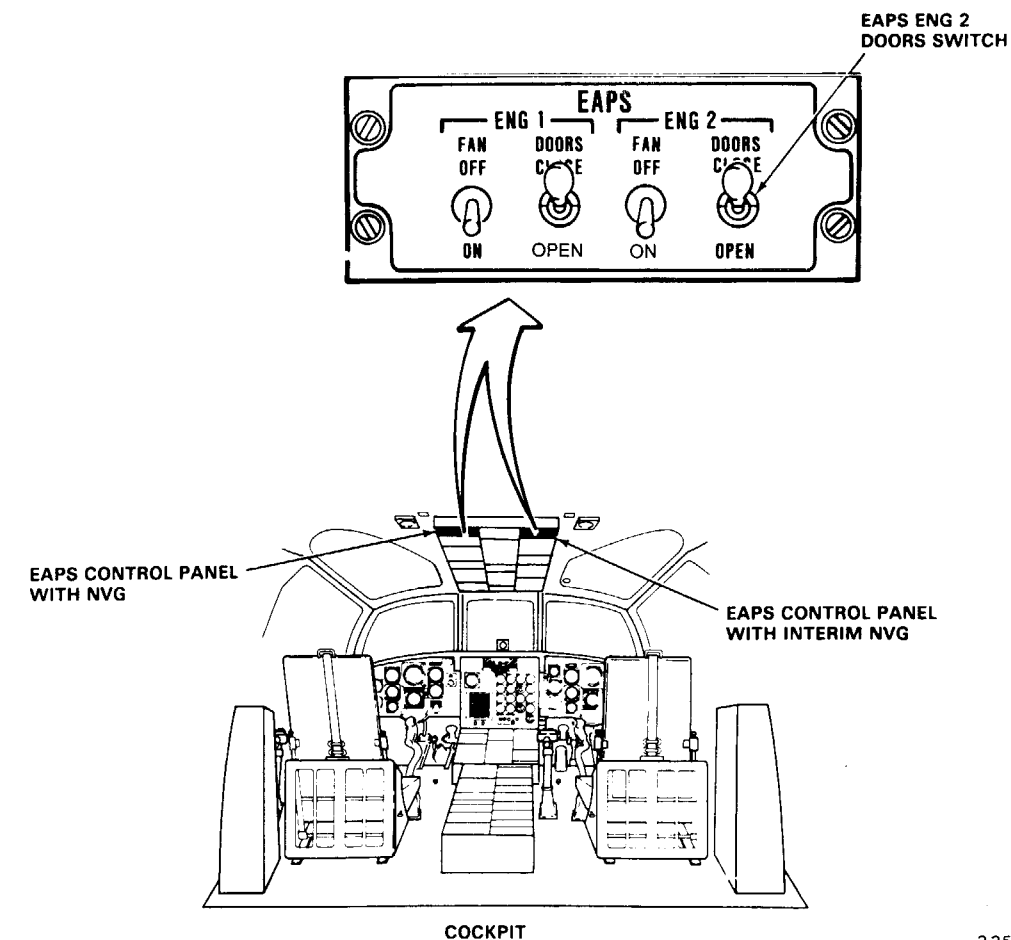
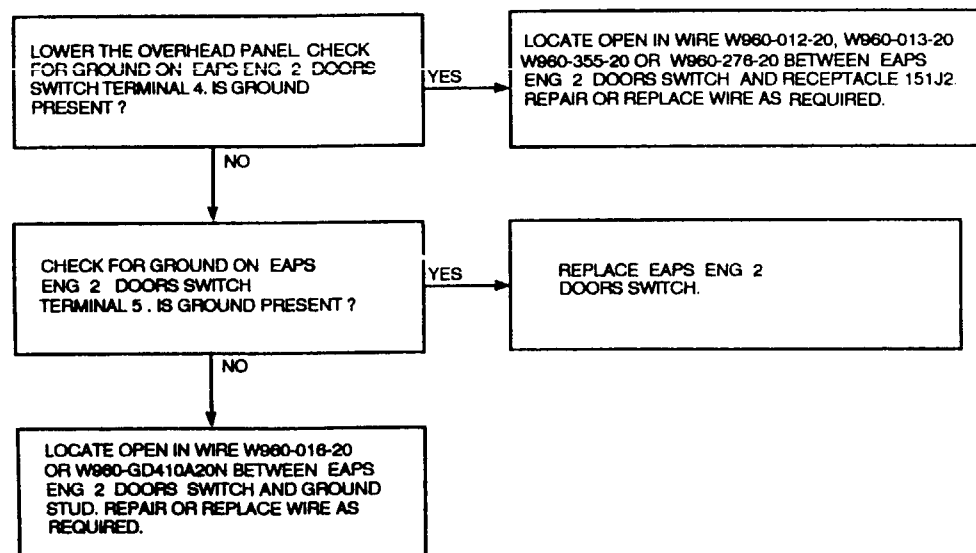
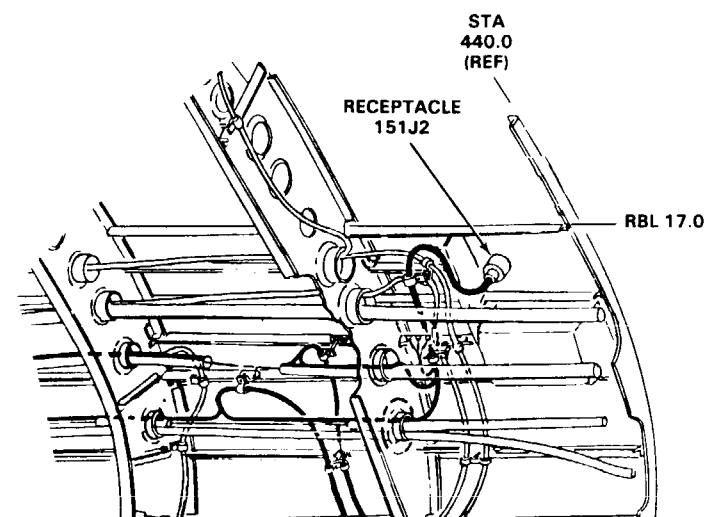

22546

16-3.19 EAPS 2 FAIL CAPSULE DOES NOT COME ON

INITIAL SFTUP

Applicable Configurations:

Helicopters with Engine Air Particle Separator Provisions

Tools:

Electrical Repairer's Tool Kit,
NSN 5180-00-323-4915
Multimeter

Materials:

None

Personnel Required:

Aircraft Electrician (2)

References:

TM 55-1520-240-23

Equipment Condition:

TM 55-1520-240-23:
Battery Connected
Electrical Power On
Hydraulic Power Off

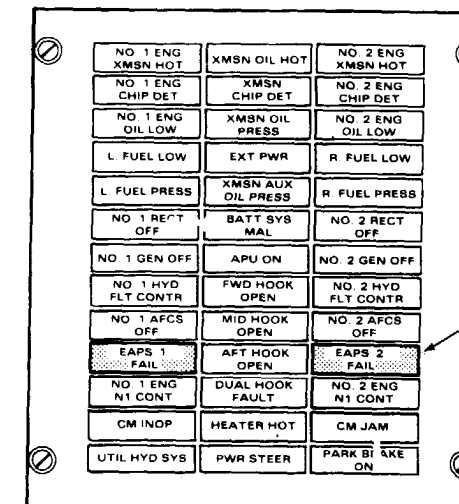
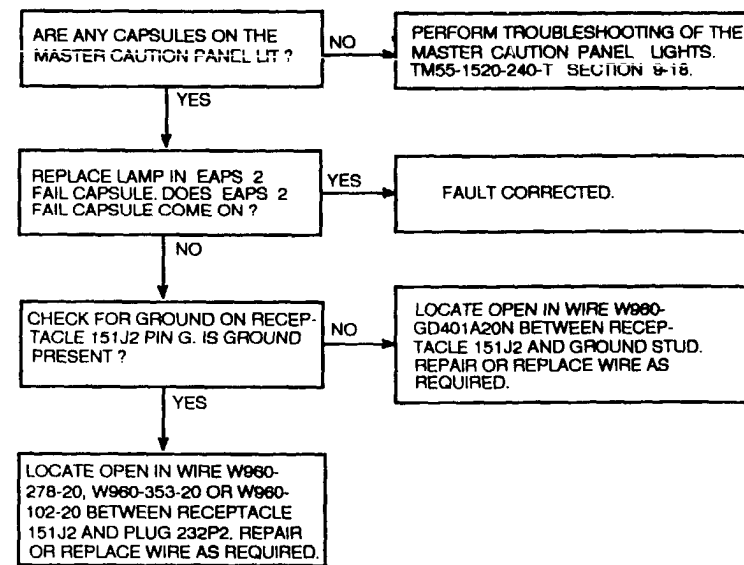
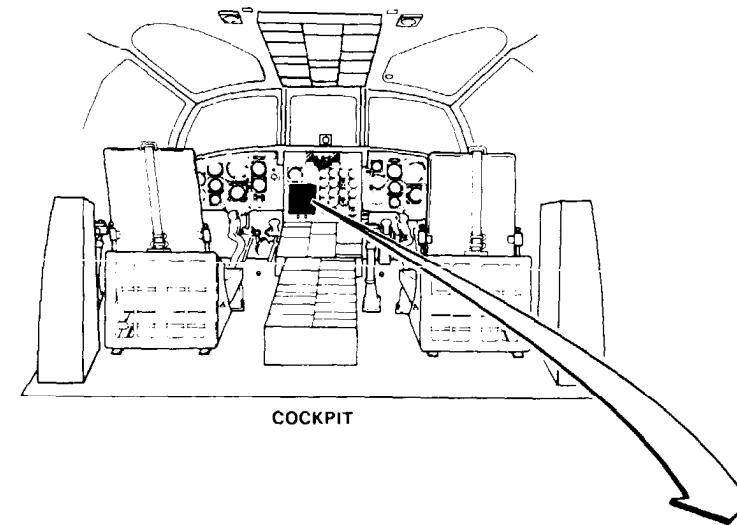
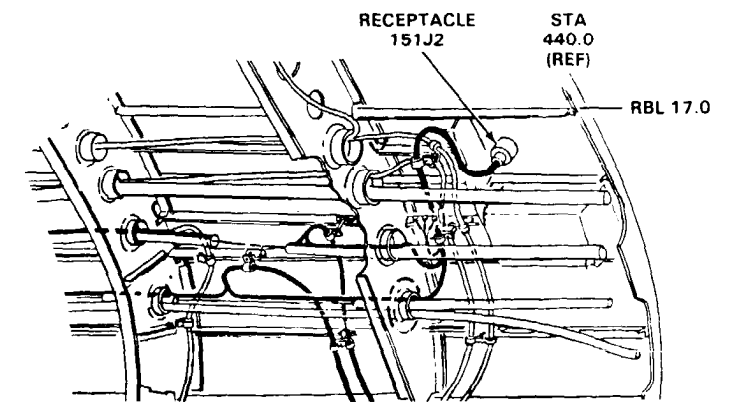

EAPS 2 FAIL CAPSULE

16-3.20 MASTER CAUTION LIGHTS WIRING DIAGRAM (Helicopters with Engine Air Particle Separator Provisions)

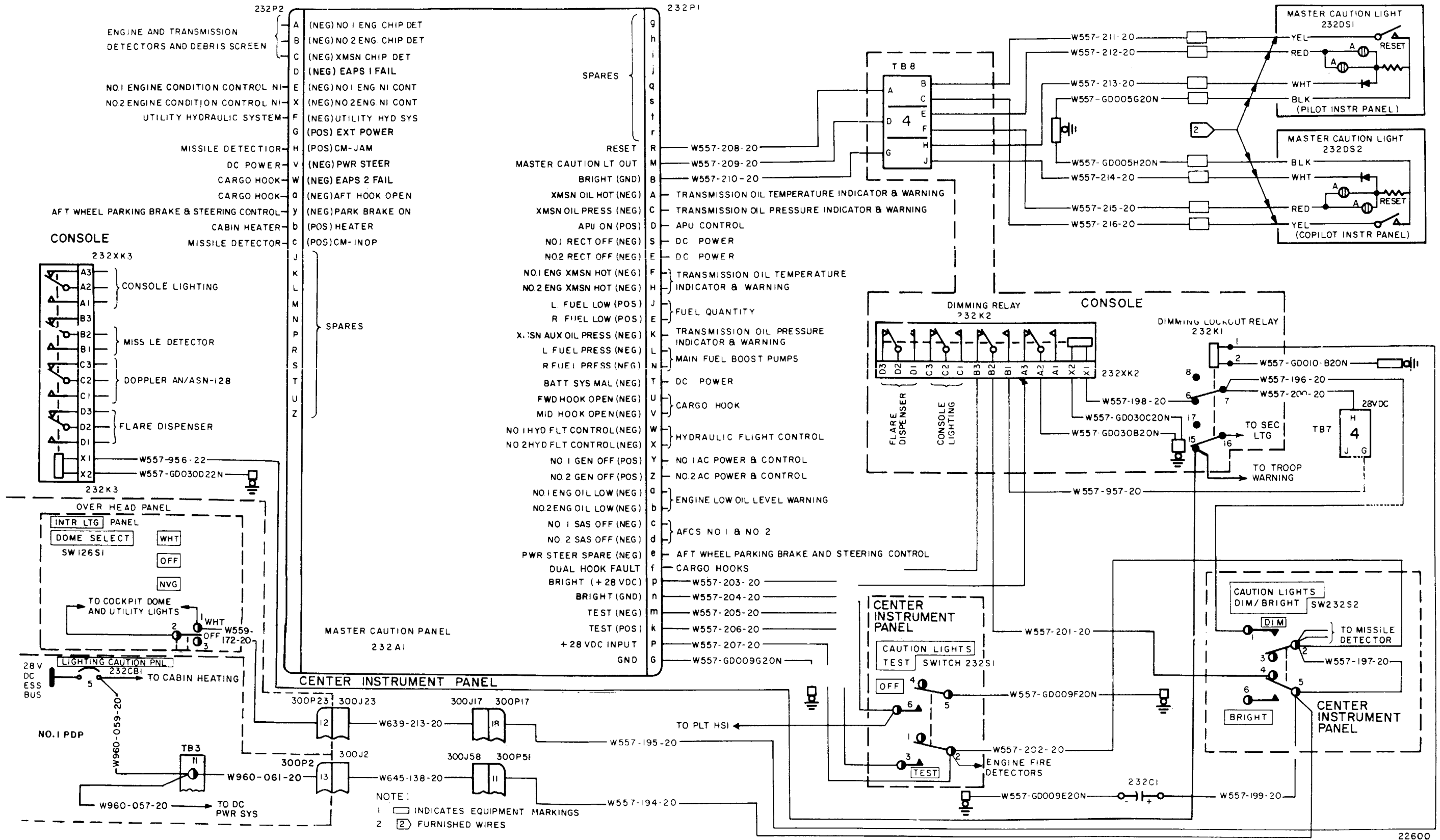

22600

INITIAL SETUP

Applicable Configurations:

Helicopters with Engine Air Particle Separator Provisions

Tools:

None

Materials:

None

Personnel Required:

Aircraft Electrician

References:

Refer to Task 9-18.3 (TM 55-1520-240-T)
TM 55-1520-240-23

Equipment Condition:

TM 55-1520-240-23:
Battery Connected
Electrical Power On
Hydraulic Power Off
Visual Check of Master Caution Lights Performed (Task 9-18.2)

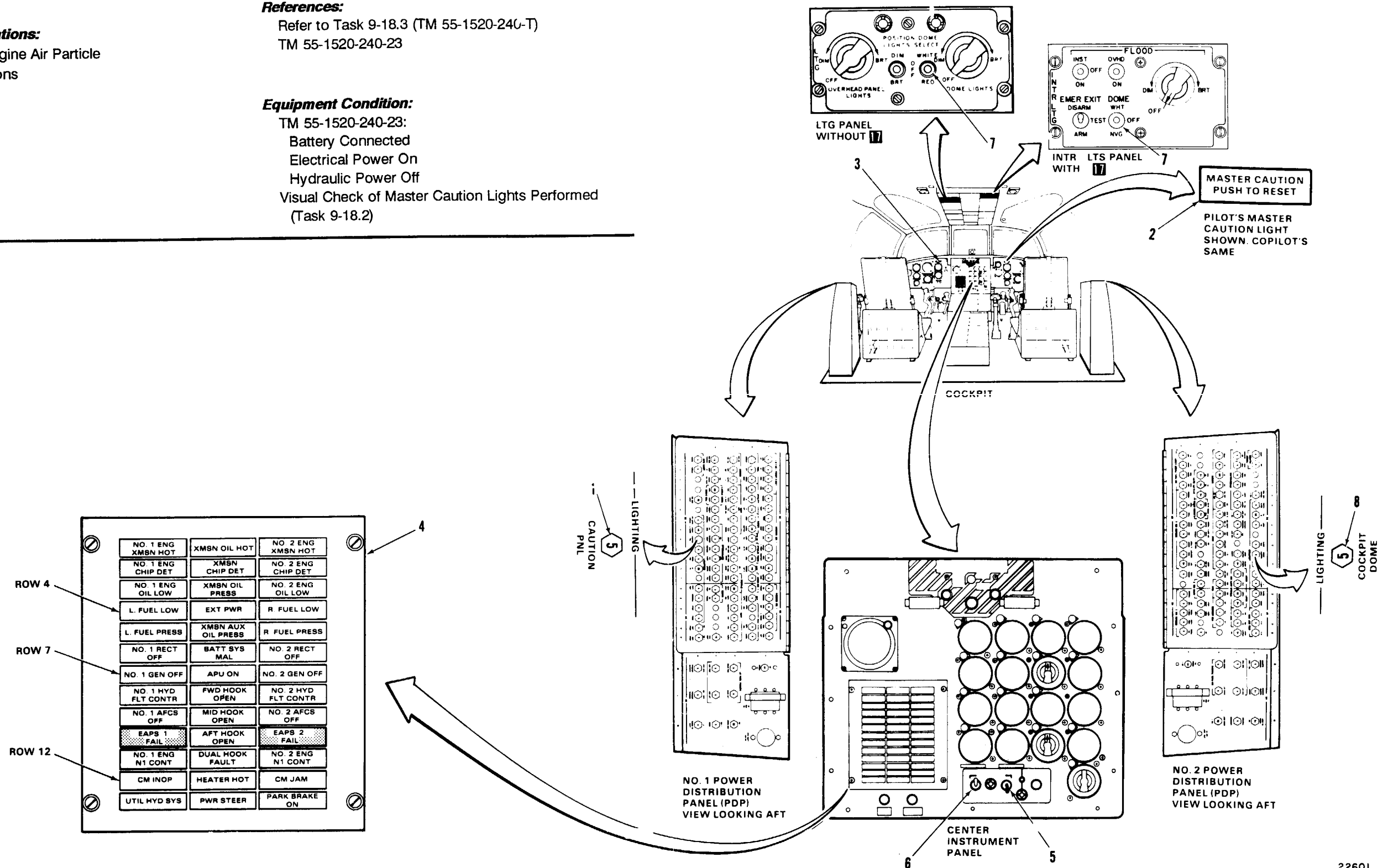

22601

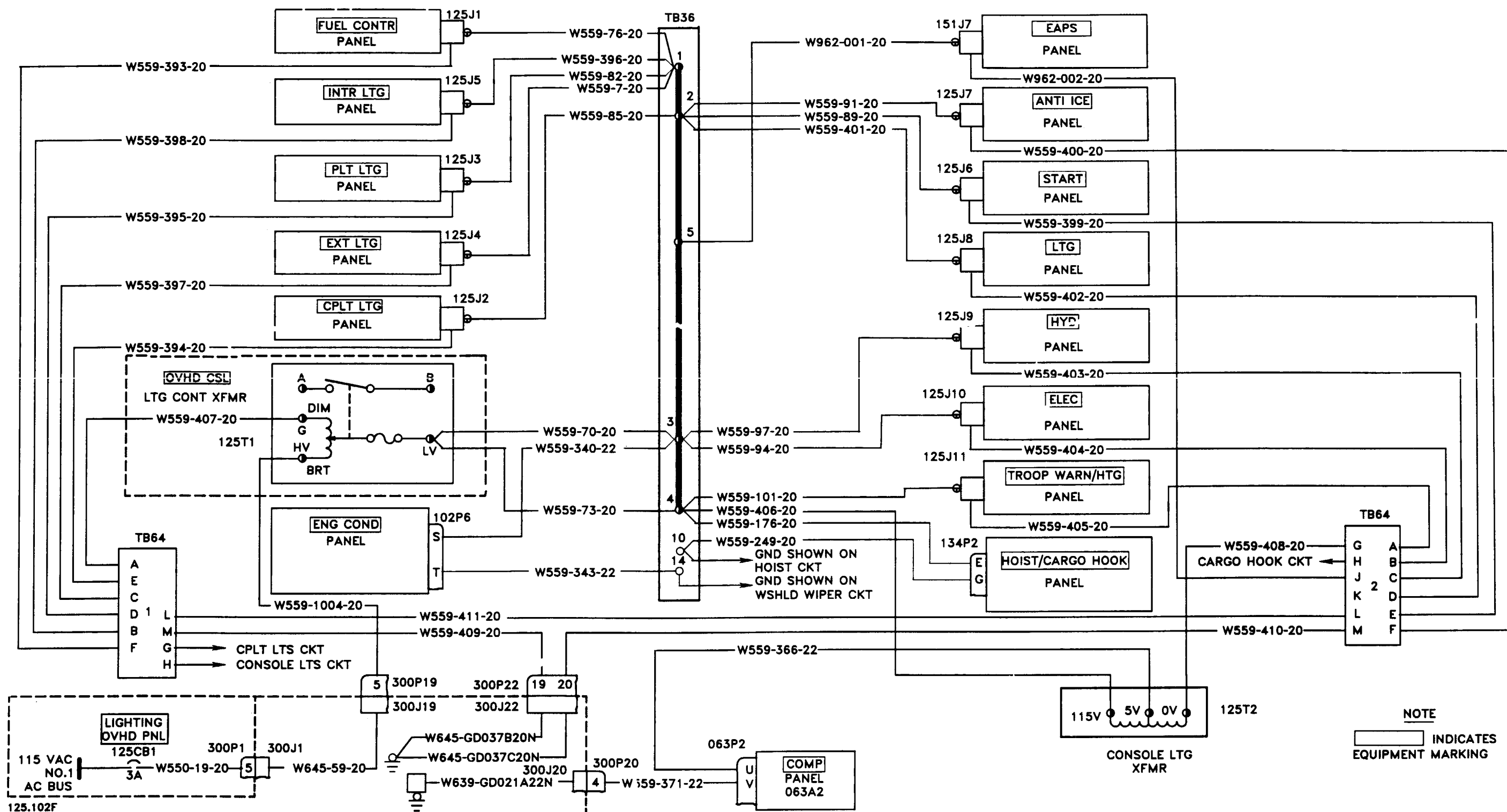

125.102F

A22602

NOTE
 [Dashed Box] INDICATES
 EQUIPMENT MARKING

INITIAL SETUP

Applicable Configurations:

- Helicopters with Engine Air Particle Separator Provisions

Tools:

- Electrical Repairer's Tool Kit, NSN 5180-00-323-4915

Materials:

- None

Personnel Required:

- Aircraft Electrician

References:

- TM 55-1520-240-23

Equipment Condition:

- TM 55-1520-240-23:
- Battery Disconnected
- Electrical Power Off
- Hydraulic Power Off

TASK	RESULT
1. Check OVHD CSL lights control (1).	If control (1) is loose or damaged, tighten or replace it as required.
2. Check 16 lightplate panels (2).	If any lightplate panel (2) is loose or damaged, tighten or replace it as required.

FOLLOW-ON MAINTENANCE:

- None

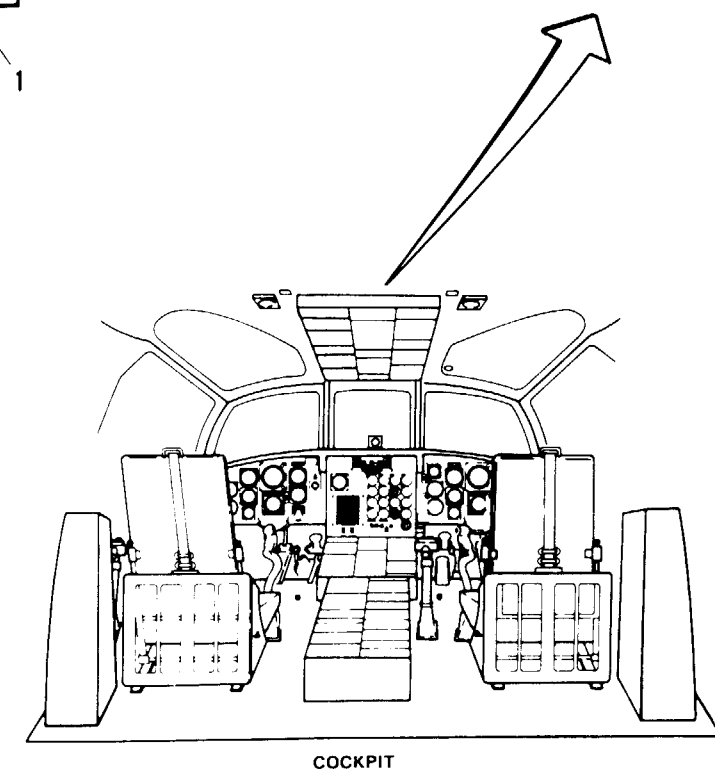
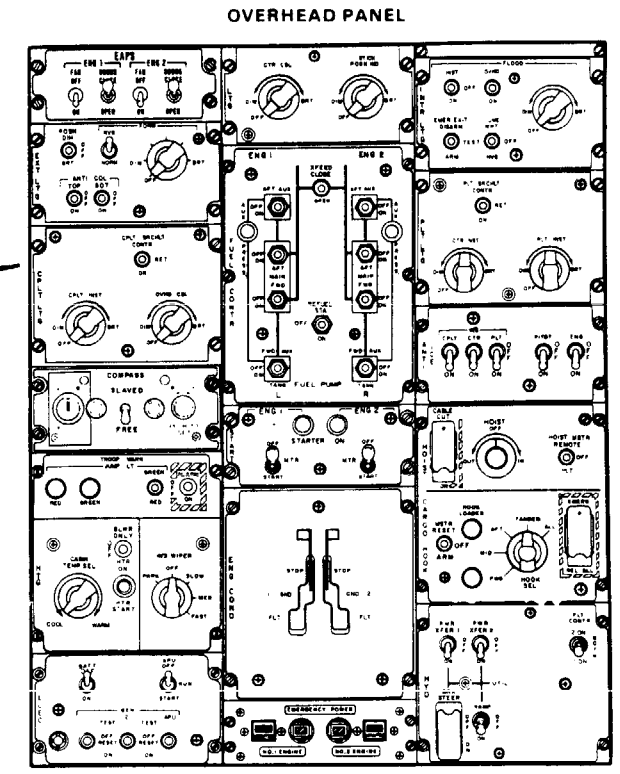
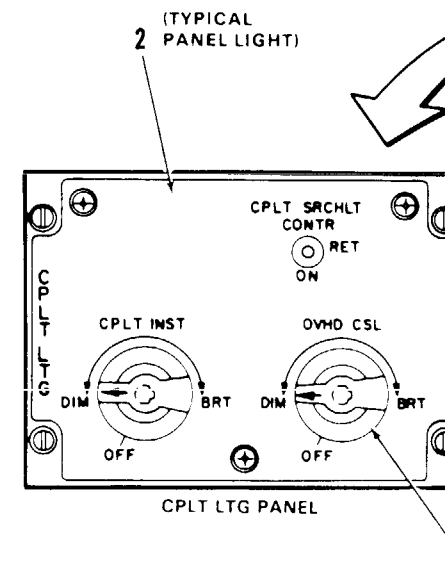

16-3.24 OVERHEAD PANEL LIGHTS OPERATIONAL CHECK

INITIAL SETUP

Applicable Configurations:

- Helicopters with Engine Air
- Particle Separator Provisions

Tools:

None

Materials:

None

Personnel Required:

Aircraft Electrician

References:

- TM 55-1520-240-23
- TM 55-1520-240-T

Equipment Condition:

- TM 55-1520-240-23:
- Battery Connected
- Electrical Power On
- Hydraulic Power Off
- Overhead Panel Lights Visual Check Performed
- Refer to Task 9-1.7 (TM 55-1520-240-T)

TASK	RESULT
1. Check that LIGHTING OVHD PNL circuit breaker (1) is closed.	If OVHD PNL circuit breaker (1) is open, close it. If it opens again, go to TM 55-1520-240-T, task 9-11.9.
2. Turn OVHD CSL lights control (2) from OFF through DIM to BRT.	All control panels in overhead panel shall light dim and increase in brightness as control (2) is turned to BRT. If any panel is not lit, go to task 9-11.10. If panel brightness does not increase as control is turned, replace OVHD CSL lights control.
3. Turn OVHD CSL lights control (2) to OFF.	All control panel lights in overhead panel shall go out. If not, replace OVHD CSL lights control.

FOLLOW-ON MAINTENANCE:

- TM 55-1520-240-23:
- Battery Disconnected
- Electrical Power Off

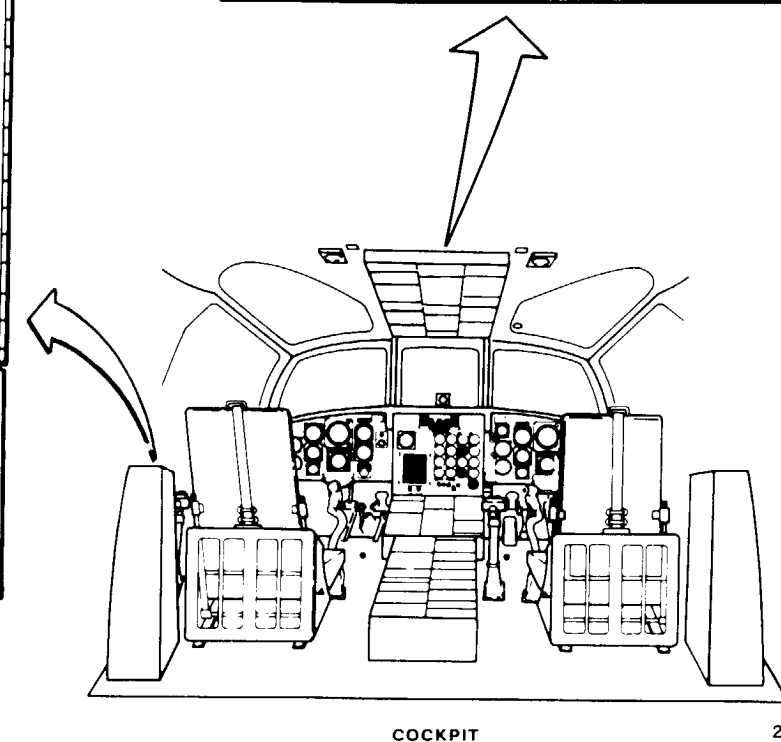
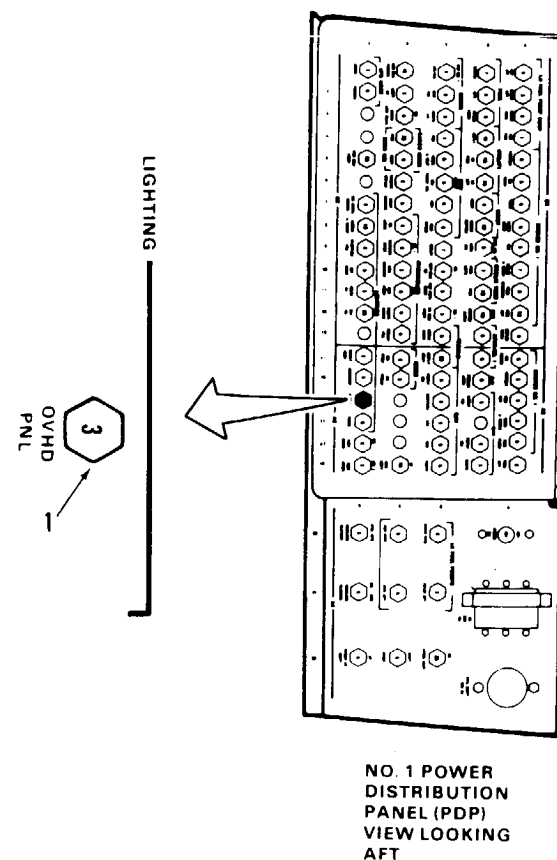
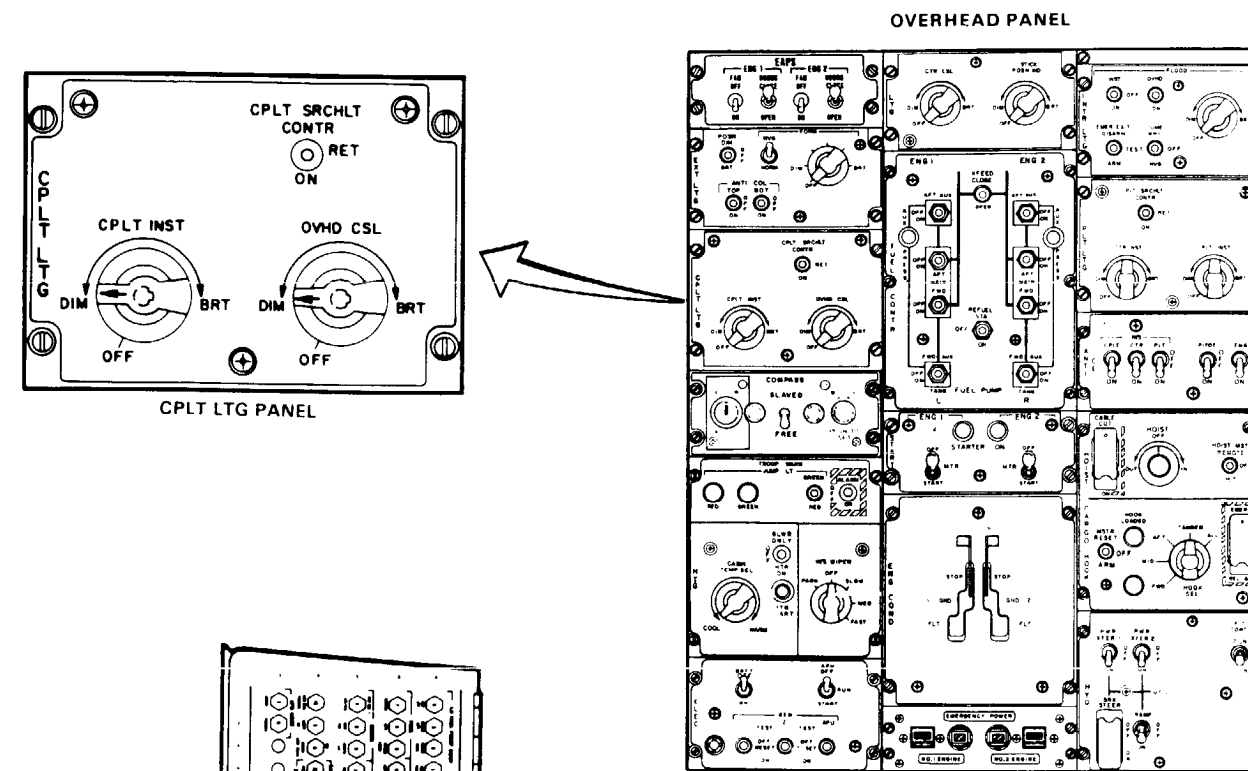

COCKPIT 22604

NO. 1 AND NO. 2 DC POWER SUPPLIES AND EXTERNAL POWER

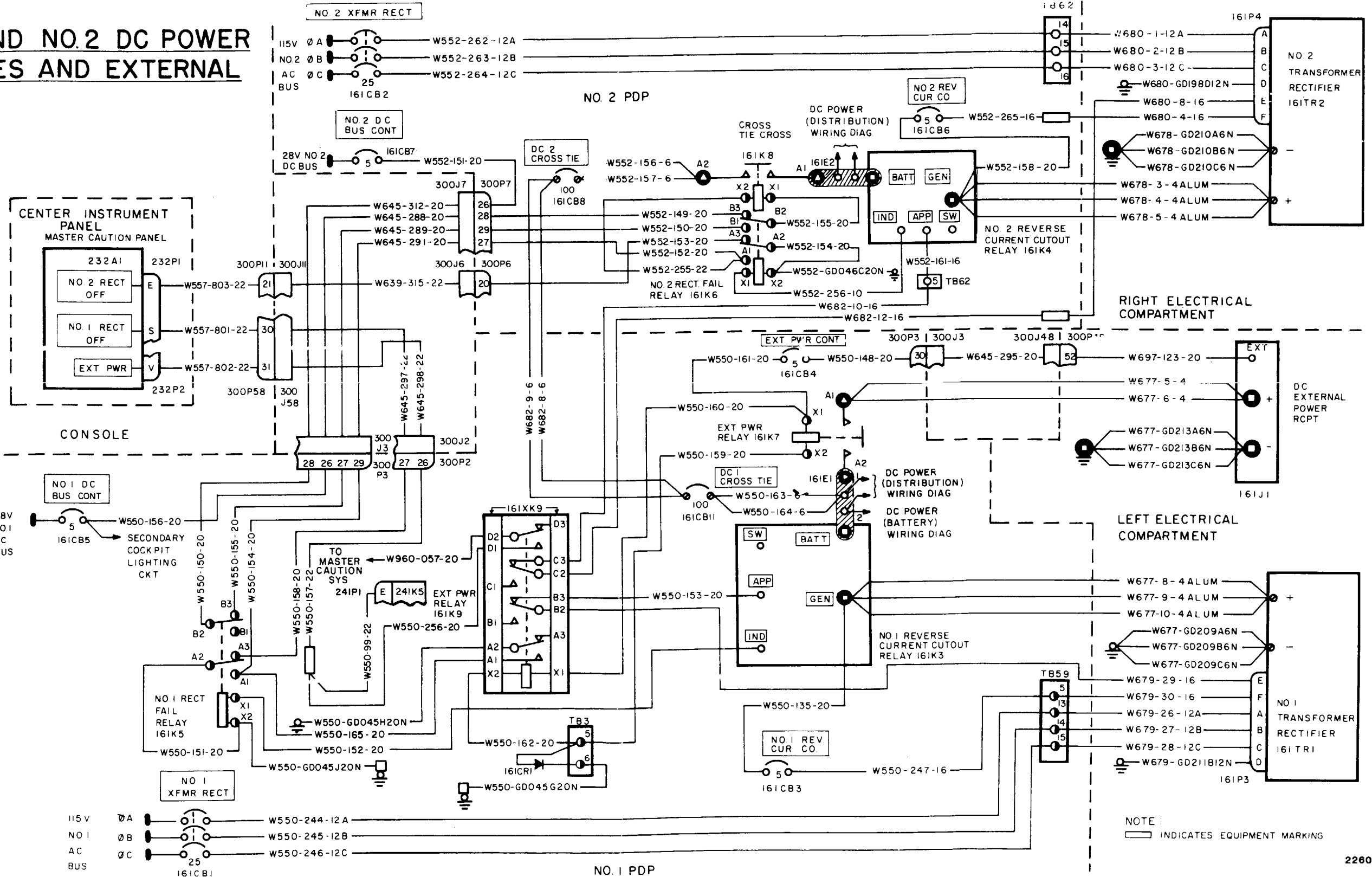

NOTE: INDICATES EQUIPMENT MARKING

22605

16-4 HEADS UP DISPLAY SYSTEM

Change 18 16-143

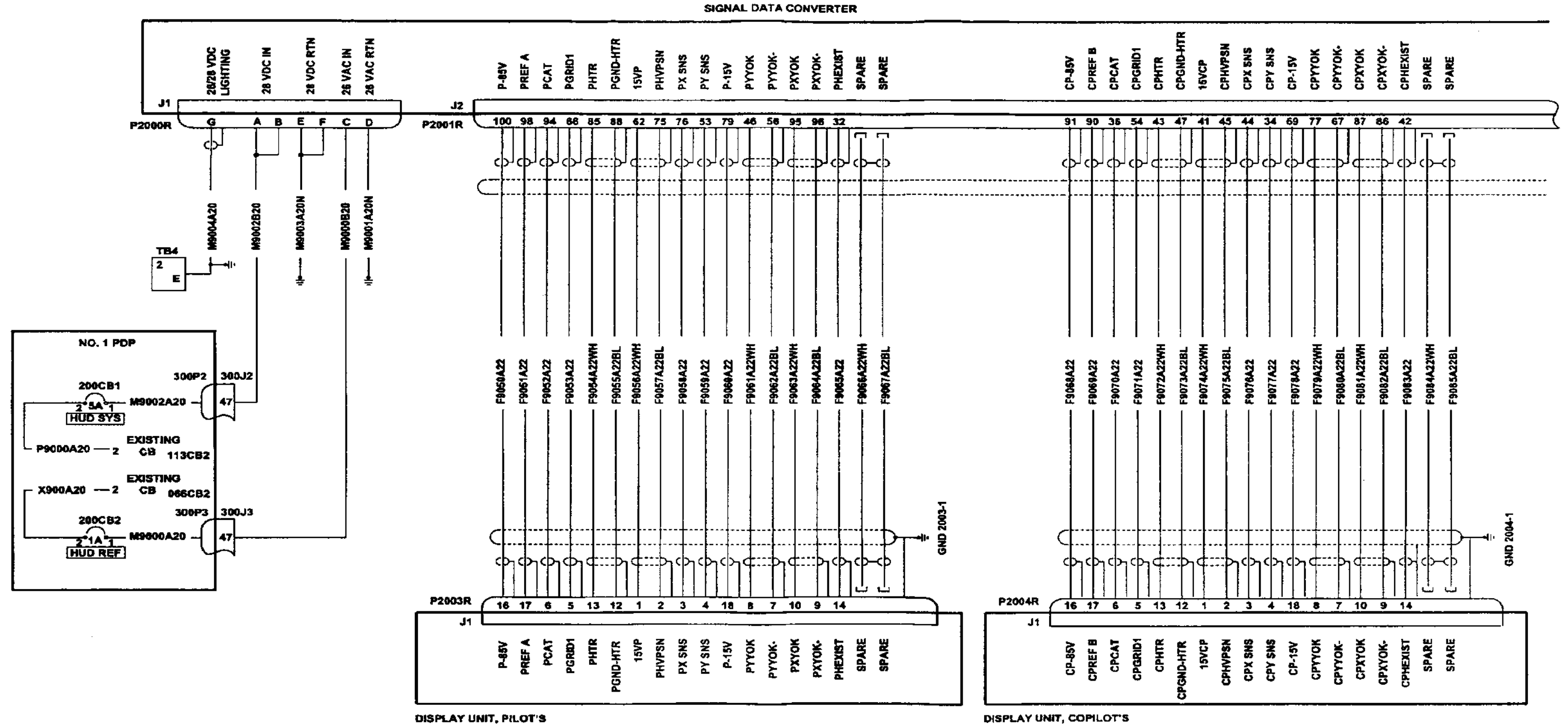

GO TO NEXT PAGE

SIGNAL DATA CONVERTER

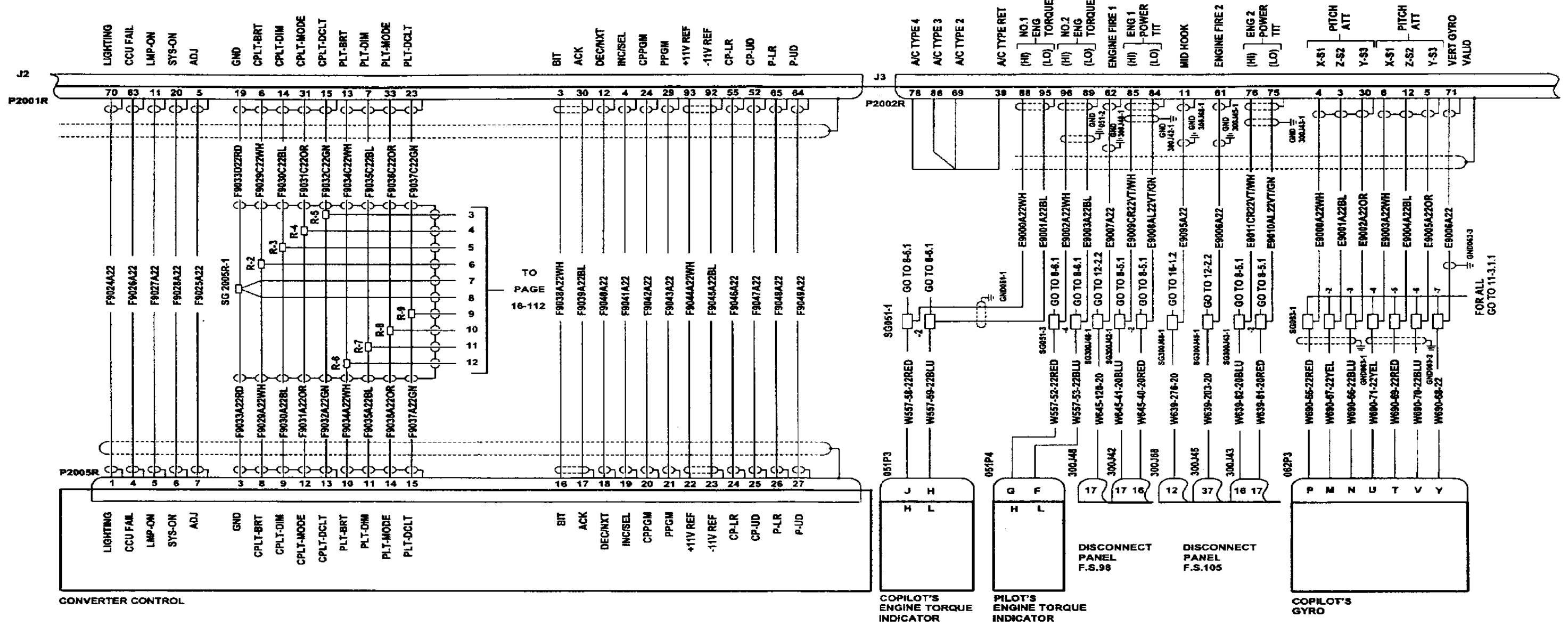

GO TO NEXT PAGE

Change 18 16-145

INITIAL SETUP:

Reference:
TM 55-1520-240-33

Applicable Configurations:

All

Tools:

Electronic Equipment Tool Kit,
NSN 5180-00-064-5178

Equipment Condition:

TM 55-1520-240-23:
Battery Connected
Electrical Power Off

Materials:

None

Personnel Required:

Avionics Mechanic
Aircraft Electrician

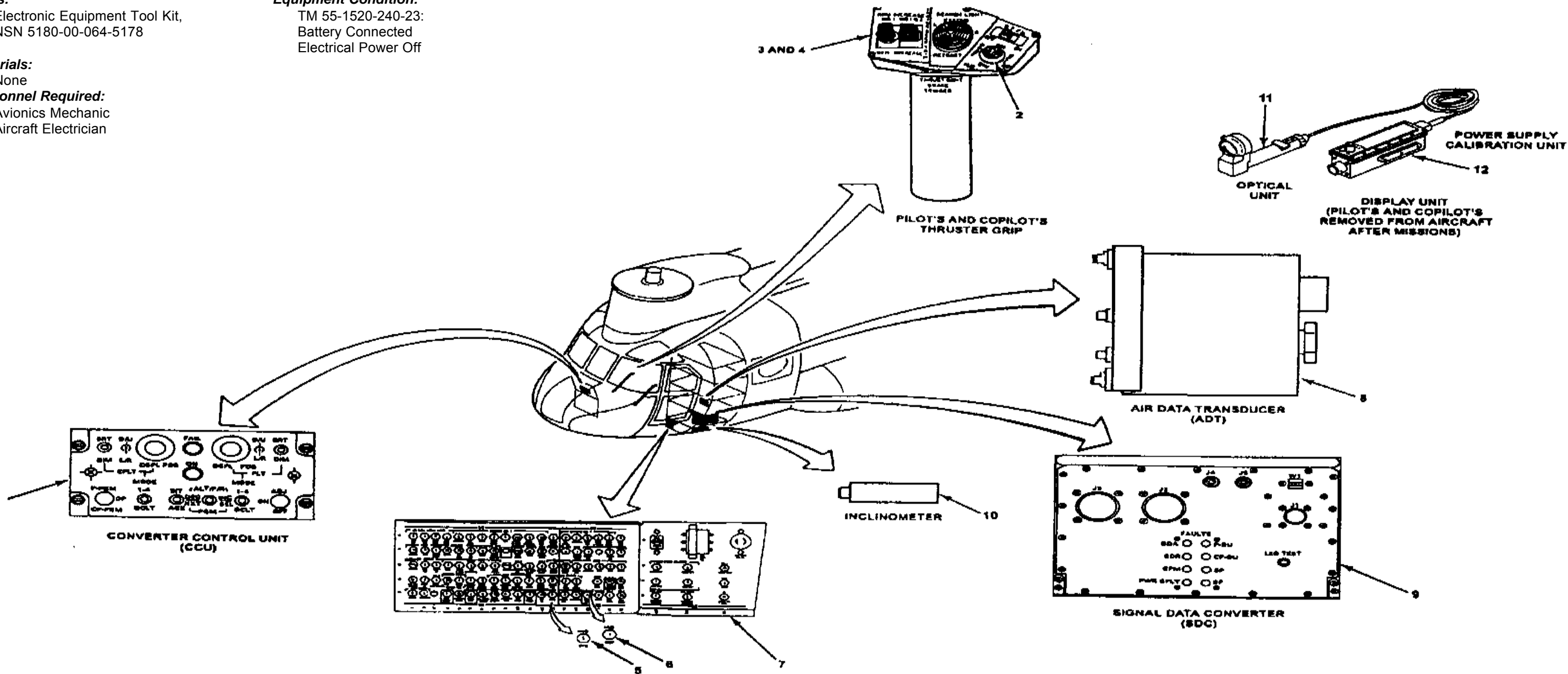

GO TO NEXT PAGE

16-4.2 HEADS UP DISPLAY SYSTEM VISUAL CHECK (Continued)

TASK	RESULT
1. Check Converter Control Unit (1).	If any switch, indicator, or control panel (1) is damaged, replace item as required.
2. Check HUD control switch (2) on pilot's (3) and copilot's (4) thruster grip.	If either switch (2) is damaged, replace HUD Control Switch.
3. Check HUD SYS circuit breaker (5) and HUD REF circuit breaker (6) on copilot's circuit breaker panel (7).	If either circuit breaker (5 or 6) is damaged, replace circuit breaker.
4. Check Air Data Transducer (8).	If transducer (8) is loose or damaged, tighten or replace it as required. If connector to transducer is loose or damaged, tighten or replace as required. If wiring to connector is damaged, repair or replace it as required.
5. Check Signal Data Converter (9).	If converter (9) is damaged or any LED on the converter is defective, replace it. If converter is loose, tighten it. If any connector to converter is loose or damaged, tighten or replace it as required. If wiring to a connector is damaged, repair or replace it as required.
6. Check Inclinator (10).	If Inclinator (10) is loose or damaged, tighten or replace it as required. If connector to Inclinator is loose or damaged, tighten or replace it as required. If wiring to the connector is damaged, repair or replace it as required.
7. Check pilot's or copilot's Display Unit's (if available) Optical Unit (11) and Power Supply Calibration Unit (12).	If either Optical Unit (11) or Power Supply Calibration Unit (12) is damaged, replace the Display Unit. If the cable between the units is damaged, repair or replace it as required.

FOLLOW-ON MAINTENANCE:

If the Converter Control Unit (1), Air Data Transducer (8), Signal Data Converter (9), Inclinator (10), or a Display Unit (11) and Power Supply Calibration Unit (12) is replaced, an operational check (16-4.3) must be performed.

INITIAL SETUP

Applicable Configurations:
All

Tools:

- Electronic Equipment Tool Kit, NSN 5180-00-064-5178
- Electrical Repairer's Tool Kit, NSN 5180-00-323-4915
- Multimeter

Materials:

None

Personnel Required:

- Avionics Mechanic
- Aircraft Electrician

References:

- TM 55-1520-240-23
- TM 11-5855-300-10
- TM 11-5855-300-23&P

Equipment Condition:

- TM 55-1520-240-23:
- Battery Connected
- Electrical Power On
- Hydraulic Power Off
- Visual Check of Heads Up Display Performed (Task 16-3.2)

General Safety Instructions:

WARNING

Keep personnel clear of flight controls.

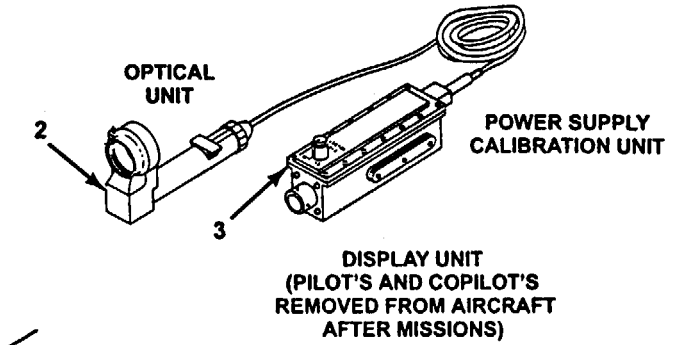

TASK	RESULT
1. With converter control unit (CCU) (1) off, connect heads up display (HUD) optical unit (2) and power supply calibration unit (3) to aircraft ANVIS system then turn on (push in) aircraft circuit breakers.	If CCU (1) panel is not illuminated, go to task 16-4.4.
2. Place CCU P-PGMIOPICP-PGM switch to OP and ADJ/ONIOFF switch to ON. CCU ON and FAIL lights illuminate and BIT proceeds automatically. After 10 seconds BIT is complete and FAIL light extinguishes.	If FAIL light does not extinguish, go to task 16-4.5. If ON and FAIL lights do not illuminate, go to task 16-4.6.
3. Place CCU PLT and CPLT BRT/DIM controls to full BRT.	If PLT and/or CPLT display has no display, go to task 16-4.7.
4. Place CCU PLT and CPLT BRT/DIM controls to full DIM.	If PLT and/or CPLT display remains at maximum intensity, go to task 16-4.8.

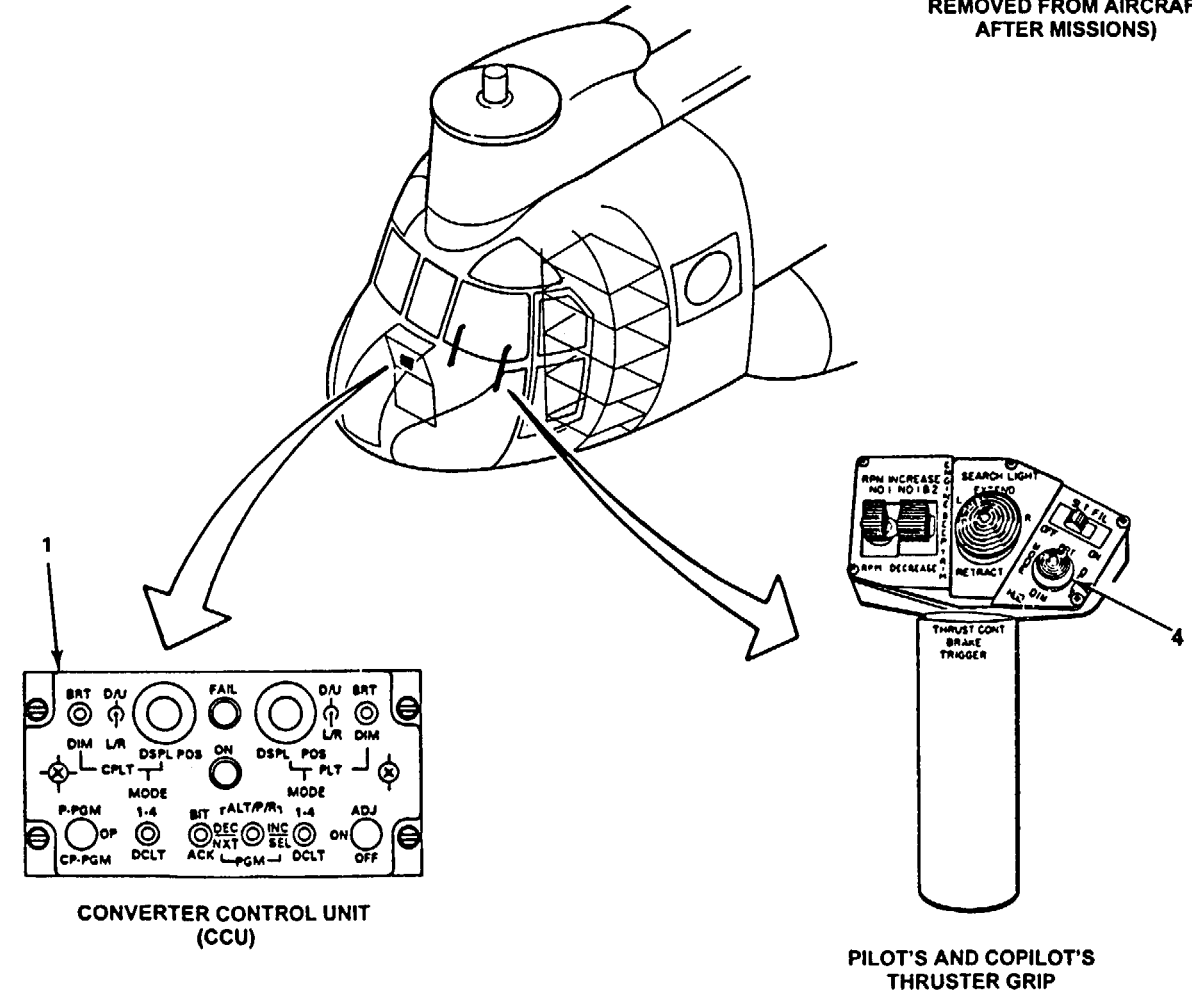

TASK RESULT

- | | | |
|----|---|---|
| 5 | Press and hold CCU BIT/ACK switch to BIT, allow 20 seconds for BIT to run then note that pilot and copilot displays show symbol generator test mode. Release CCU BIT/ACK switch to return display units to operating mode. | If one test display is incorrect, replace that display unit. If both test displays are incorrect, replace the signal data converter. If both displays indicate incorrect type aircraft, go to task 16-4.9. |
| 6. | Refer to TM 11-5855-300-10 and program the pilot's then the copilot's display. On completion of programming, return CPU P-PGM/OP/CP-PGM switch to OP. | If a symbol does not stop blinking when programmed, go to task 16-4.10. If PLT DCLT will not select, go to task 16-4.11. If CPLT DCLT will not select, go to task 16-4.12. |
| 7. | Set pilot's/copilot's thruster grip HUD control switch (4) to cycle through four MODE/DCLT positions and check the BRT and DIM operation. are 16-4.17; 16-4.18; 16-4.19; or 16-4.20. | If the pilot thruster grip HUD switch will not cycle through all modes, through declutter, and brighten or dim display, go to tasks 16-4.13; 16-4.14; 16-4.15; or 16-4.16 respective tasks |
| 8. | On the CCU, rotate pilot's/copilot's DISPL POS control to full LIR (left/right) then D/U (down/up) positions. Check that the display follows the control. | If the pilot's display will not follow the UR or the D/U control, go to task 16-4.21 or 16-4.22 respectively. For the copilot, go to tasks 16-4.23 or 16-4.24 respectively. |
| 9. | With the CCU P-PGM/OP/CP-PGM switch in OP, set the ADJON/OFF switch to ADJ. Using the DEC/INC switch, check that the data can be changed then set to the required value. The MSL altitude, the pitch, then the roll are adjusted in turn. | If the MSL altitude (1) or airspeed (3) is improperly displayed, go to task 16-4.29. If the trim (2) is improperly displayed, go to task 16-4.30. If any adjustment can be make, refer to TM 11-5855-30-23&P to troubleshoot the HUD. |

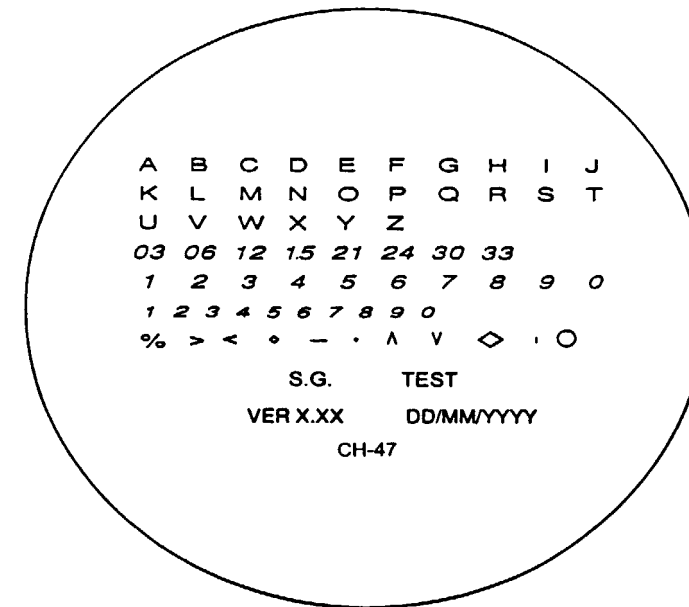

NOTE: VERSION NUMBER AND DATE WILL CHANGE AS SOFTWARE IS UPDATED.

Symbol Generator Test Mode

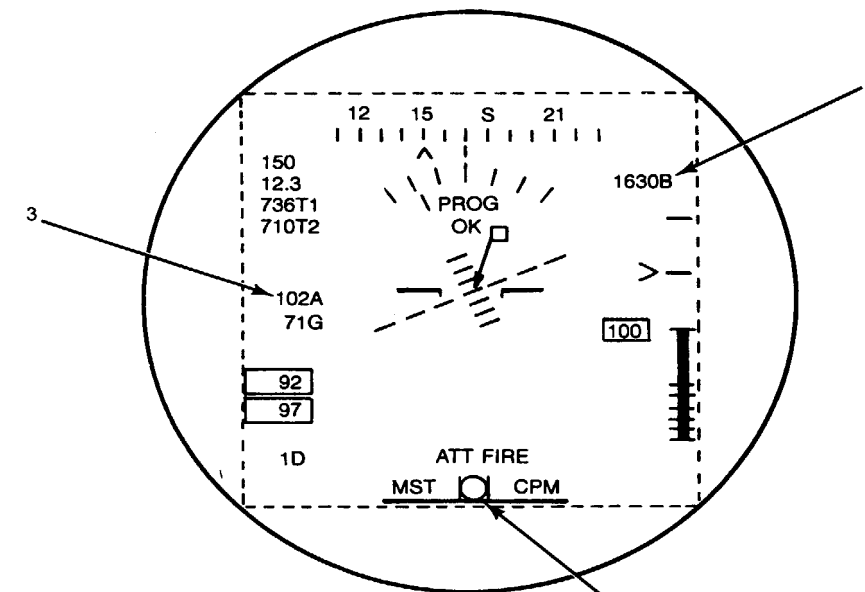

CH-47D HUD Master Mode Display

FOLLOW-ON MAINTENANCE:
 TM 55-1520-240-23:
 Remove power from HUD system
 Remove Electrical Power
 Disconnect Battery

16-4.5 FAIL LAMP ON CCU IS ON

FAULT ISOLATION PROCEDURE

INITIAL SETUP

Applicable Configurations:

All

Tools:

Electronic Equipment Tool Kit,
NSN 5180-00-064-5178
Multimeter

Materials:

None

Personnel Required:

Avionics Mechanic

References:

TM 55-1520-240-23
TM 11-5855-300-23&P

Equipment Condition:

TM 55-1520-240-23:
Battery Connected
Electrical Power On

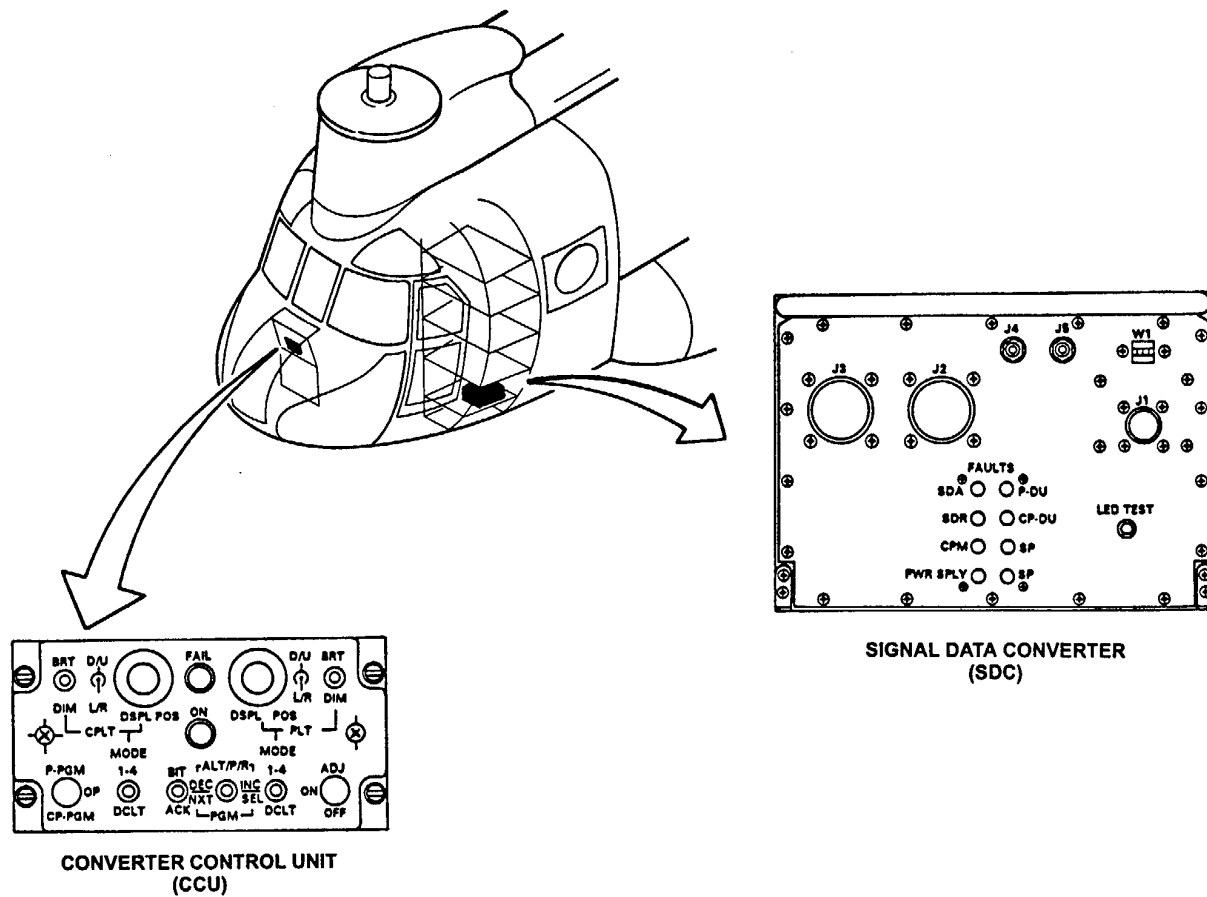
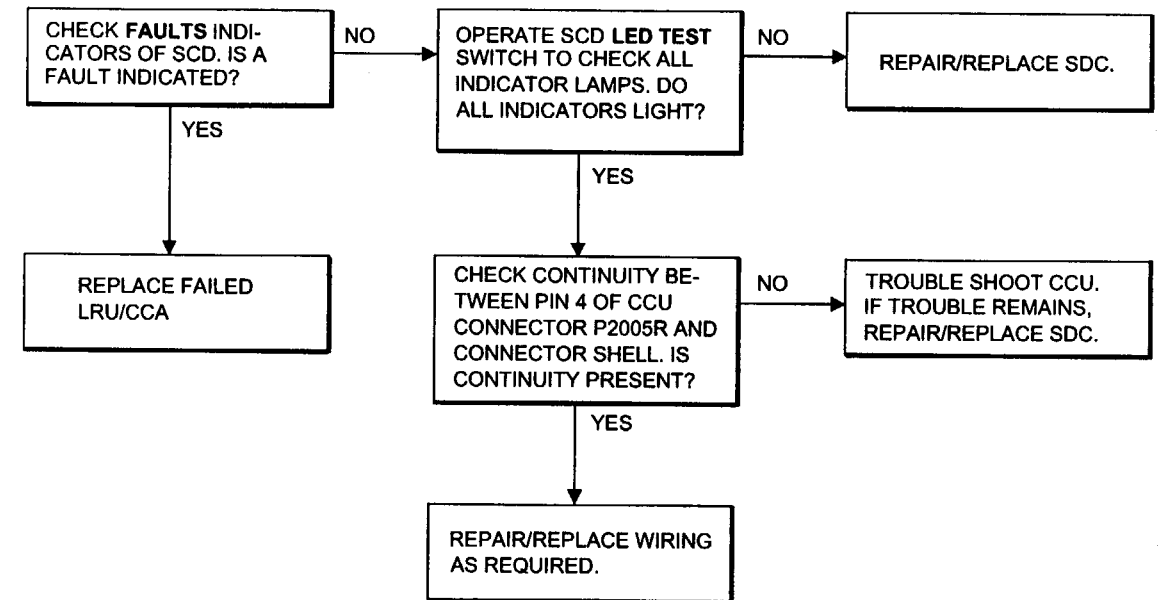

FAULT ISOLATION PROCEDURE

Personnel Required:

Avionics Mechanic
INITIAL SETUP

Applicable Configurations:
All

References:
TM 55-1520-240-23
TM 11-5855-300-23&P

Tools:
Electronic Equipment Tool Kit,
NSN 5180-00-064-5178
Multimeter

Equipment Condition:
TM 55-1520-240-23:
Battery Connected
Electrical Power On

Materials:
None

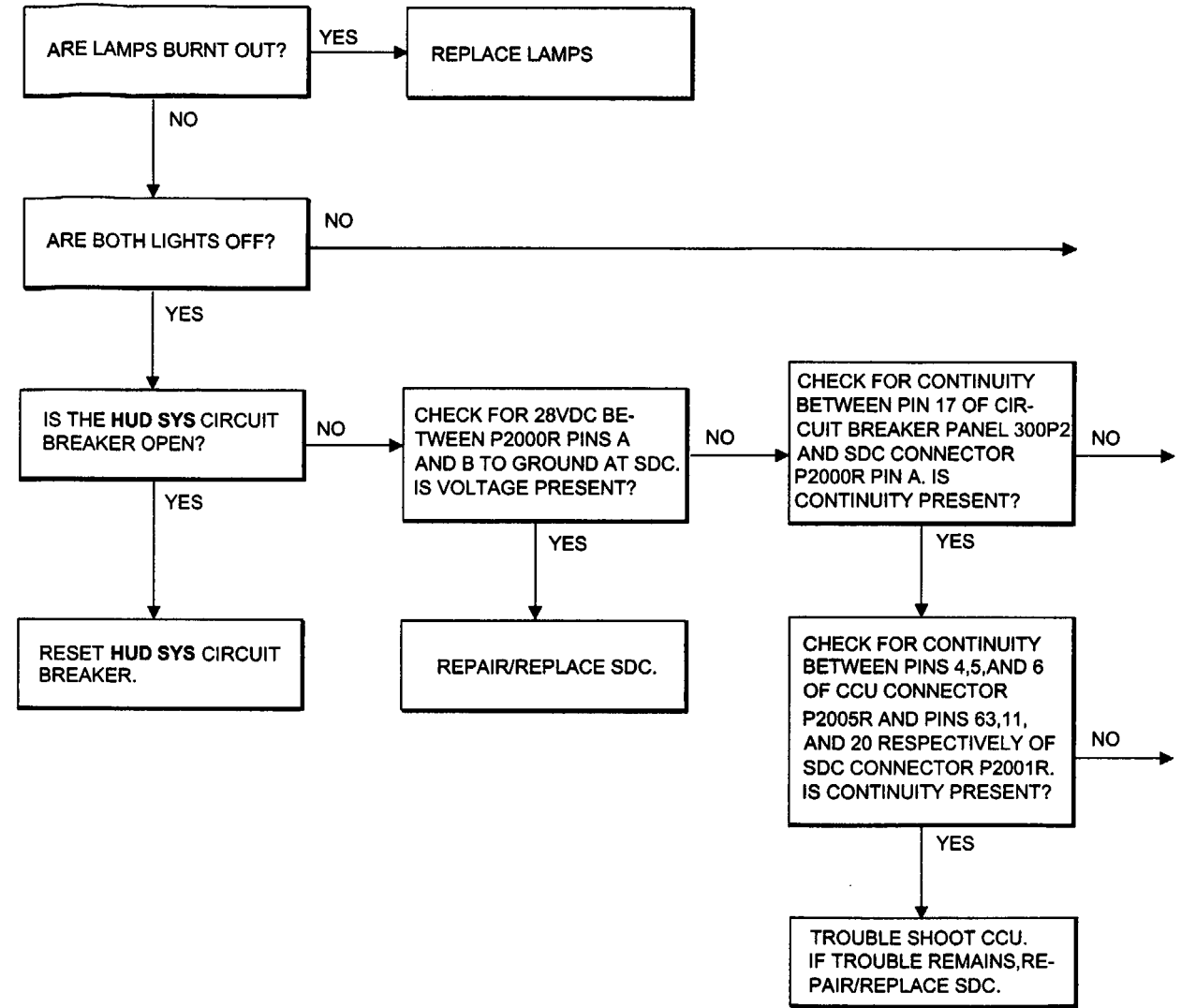
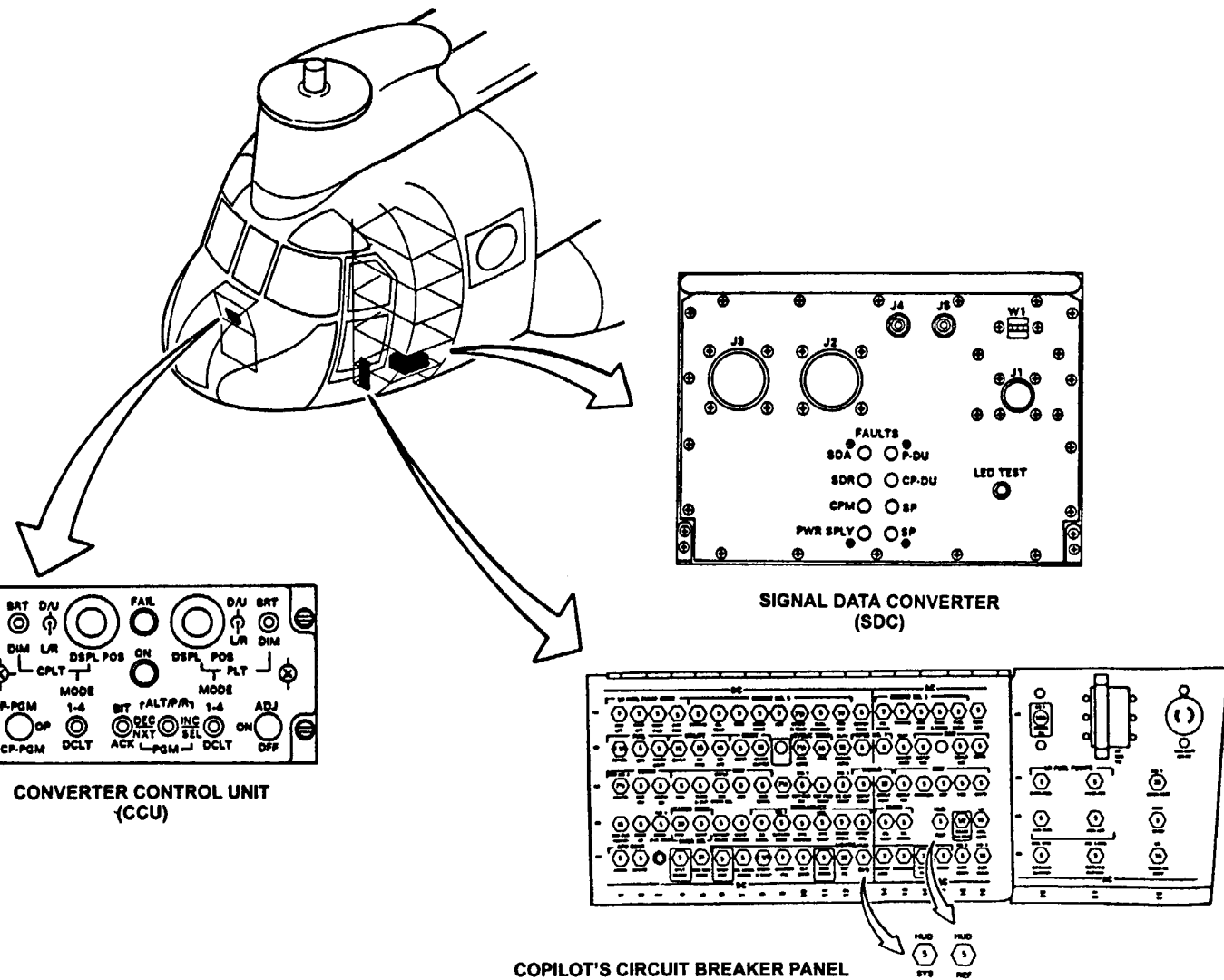

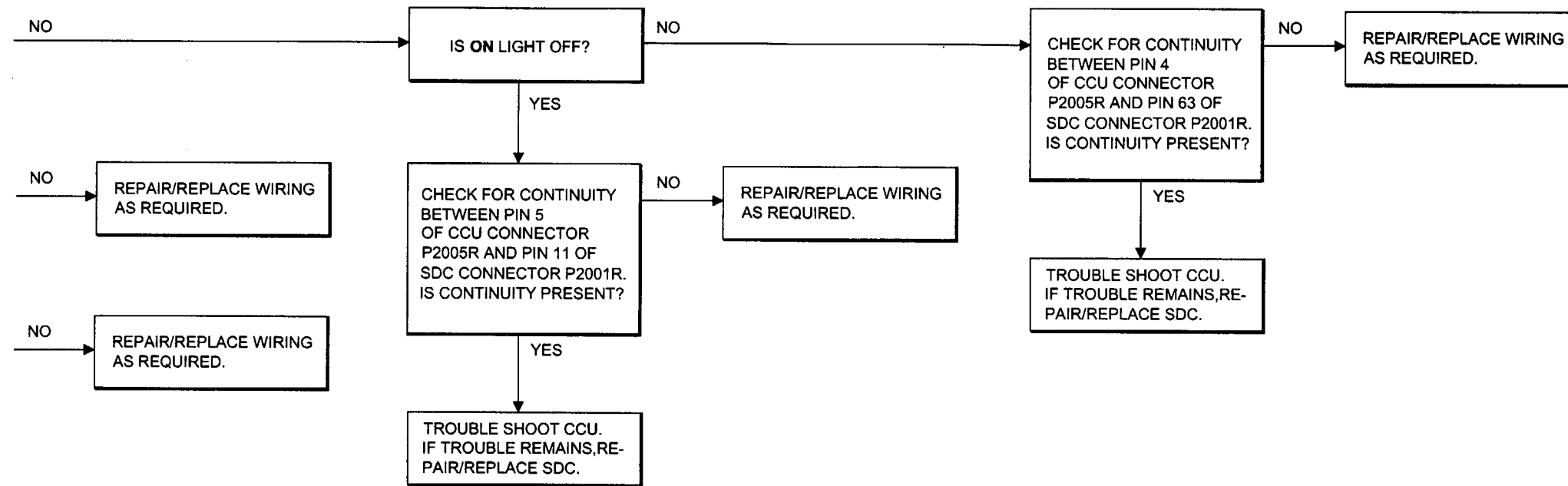

END OF TASK
Change 18 16-155

FAULT ISOLATION PROCEDURE

Avionics Mechanic

INITIAL SETUP

Applicable Configurations:

All

Tools:

Electronic Equipment Tool Kit,
NSN 5180-00-064-5178
Multimeter

Materials:

None

Personnel Required:

References:

TM 55-1520-240-23
TM 11-5855-300-23&P

Equipment Condition:

TM 55-1520-240-23:
Battery Connected
Electrical Power On

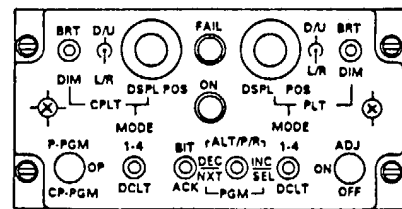
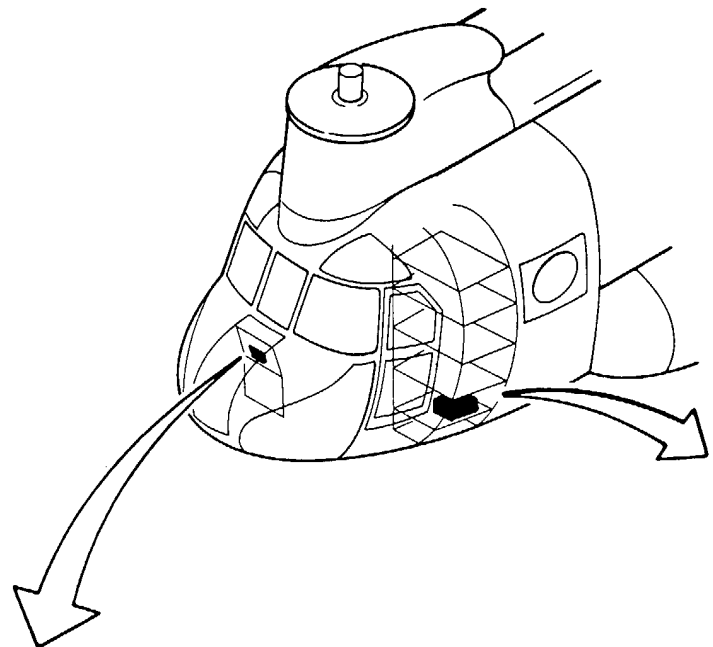

CONVERTER CONTROL UNIT (CCU)

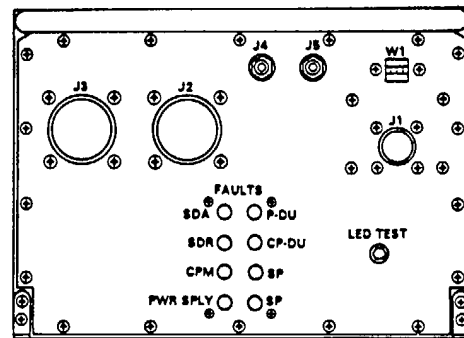

SIGNAL DATA CONVERTER (SDC)

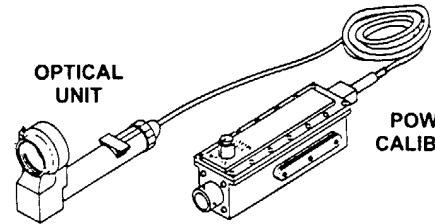

DISPLAY UNIT (PILOT'S AND COPILOT'S REMOVED FROM AIRCRAFT AFTER MISSIONS)

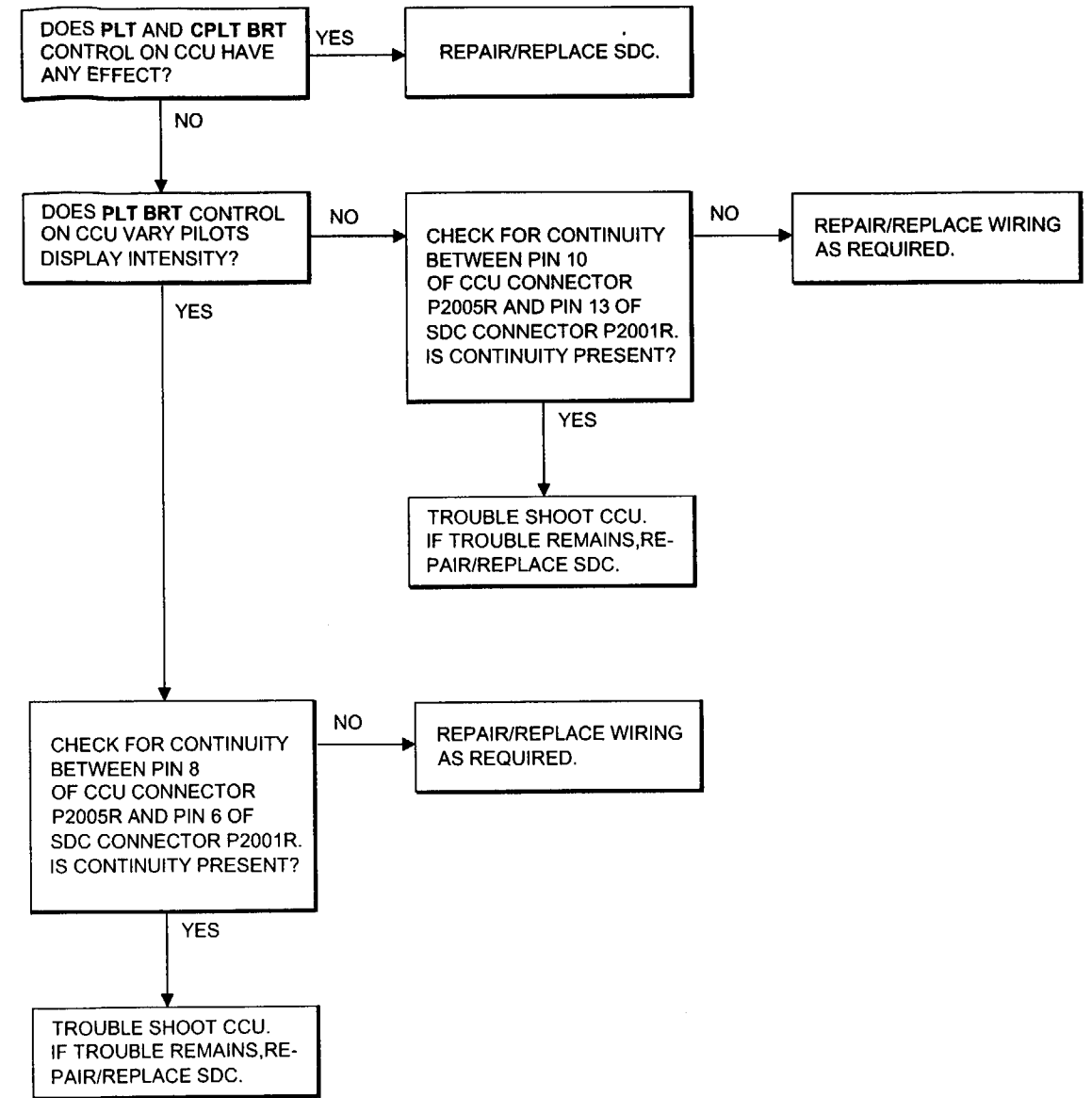

FAULT ISOLATION PROCEDURE

Avionics Mechanic

INITIAL SETUP

Applicable Configurations:

All

Tools:

Electronic Equipment Tool Kit,
NSN 5180-00-064-5178
Multimeter

Materials:

None

Personnel Required:

References:

TM 55-1520-240-23
TM 11-5855-300-23&P

Equipment Condition:

TM 55-1520-240-23:
Battery Connected
Electrical Power On

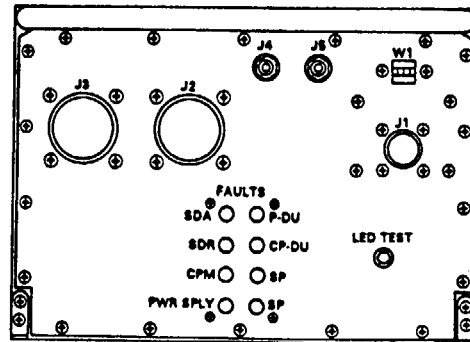
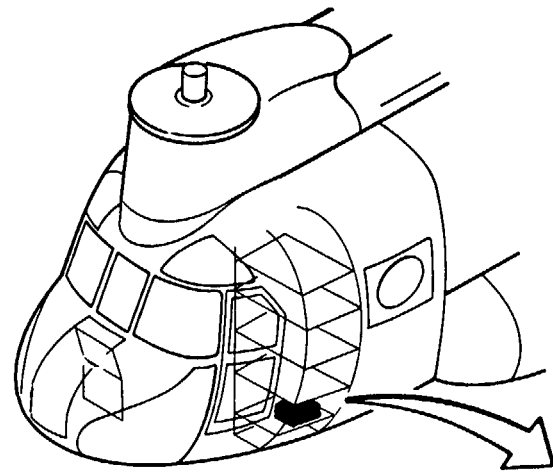

SIGNAL DATA CONVERTER (SDC)

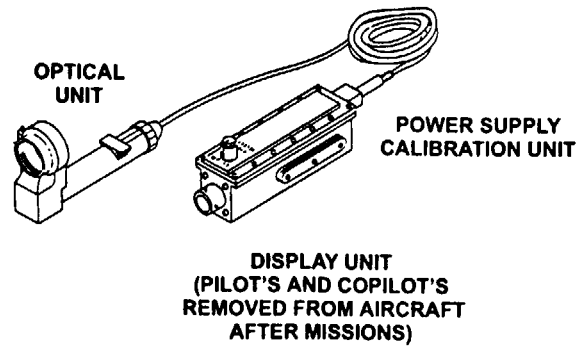

DISPLAY UNIT
(PILOT'S AND COPILOT'S
REMOVED FROM AIRCRAFT
AFTER MISSIONS)

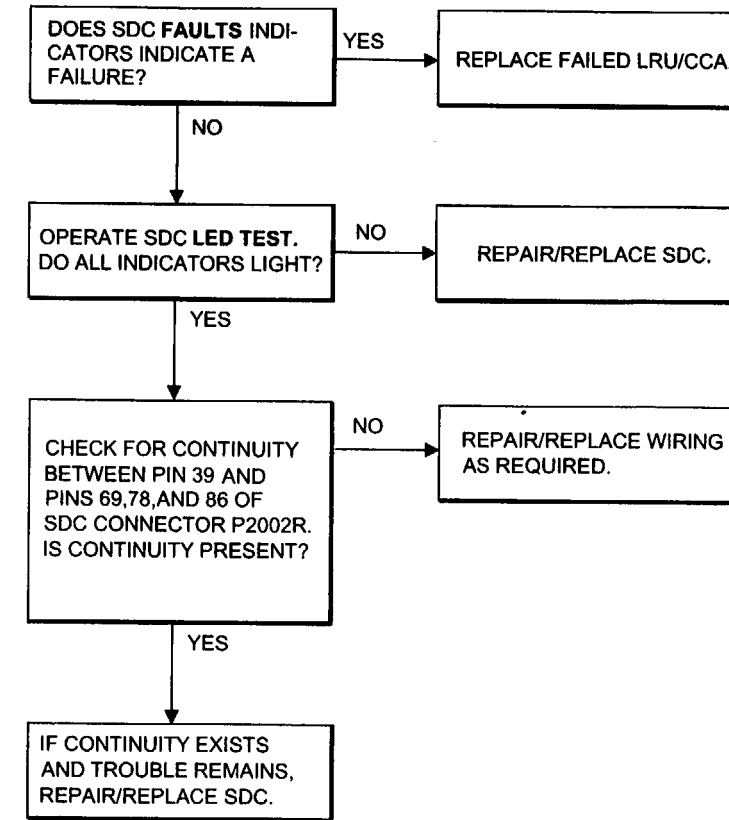

16-4.10 SYMBOL DOES NOT STOP BLINKING

16-4.10

FAULT ISOLATION PROCEDURE

Personnel Required:
Avionics Mechanic

INITIAL SETUP

Applicable Configurations:
All

References:
TM 55-1520-240-23
TM 11-5855-300-23&P

Tools:

Electronic Equipment Tool Kit,
NSN 5180-00-064-5178
Multimeter

Equipment Condition:
TM 55-1520-240-23:
Battery Connected
Electrical Power On

Materials:

None

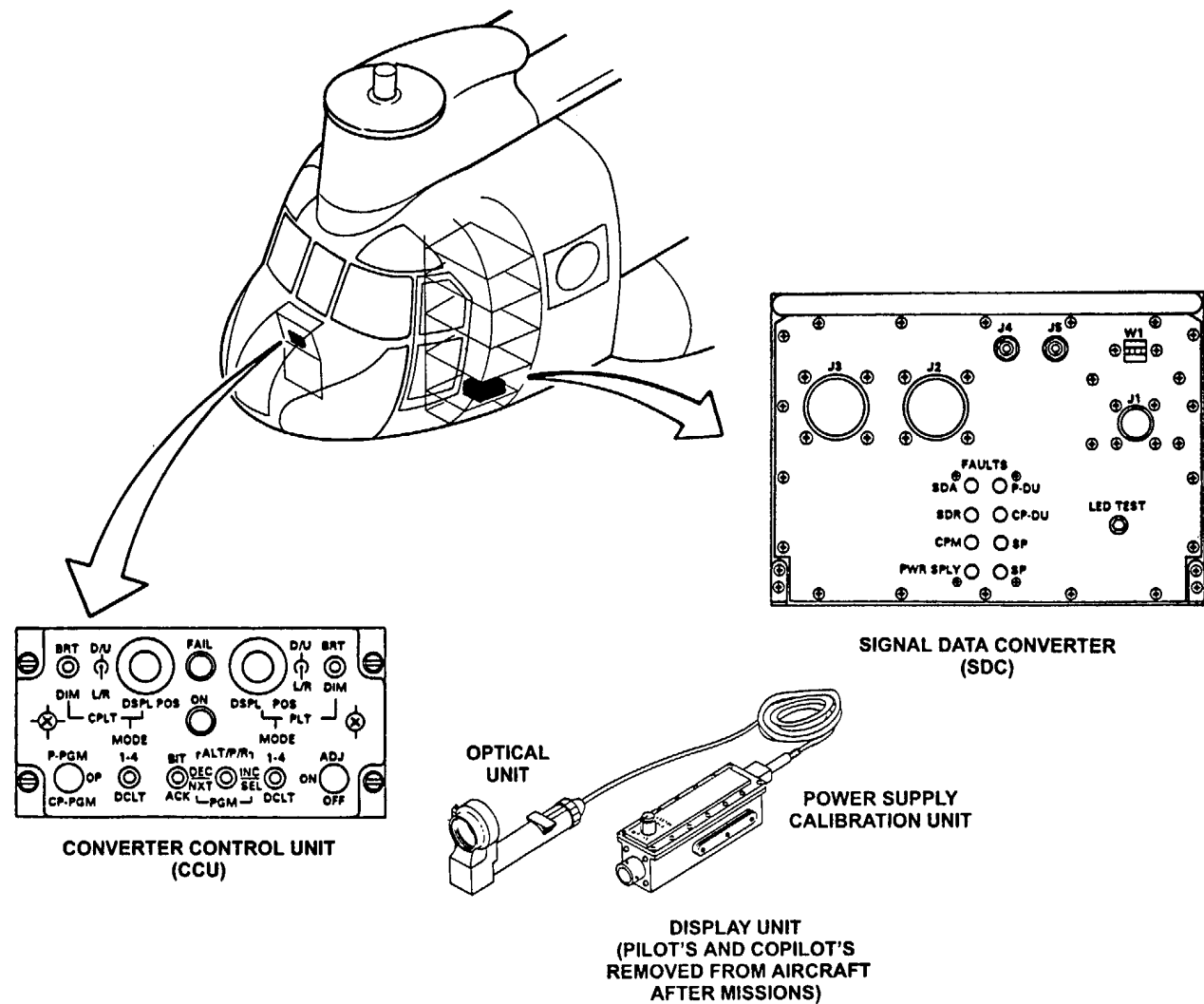
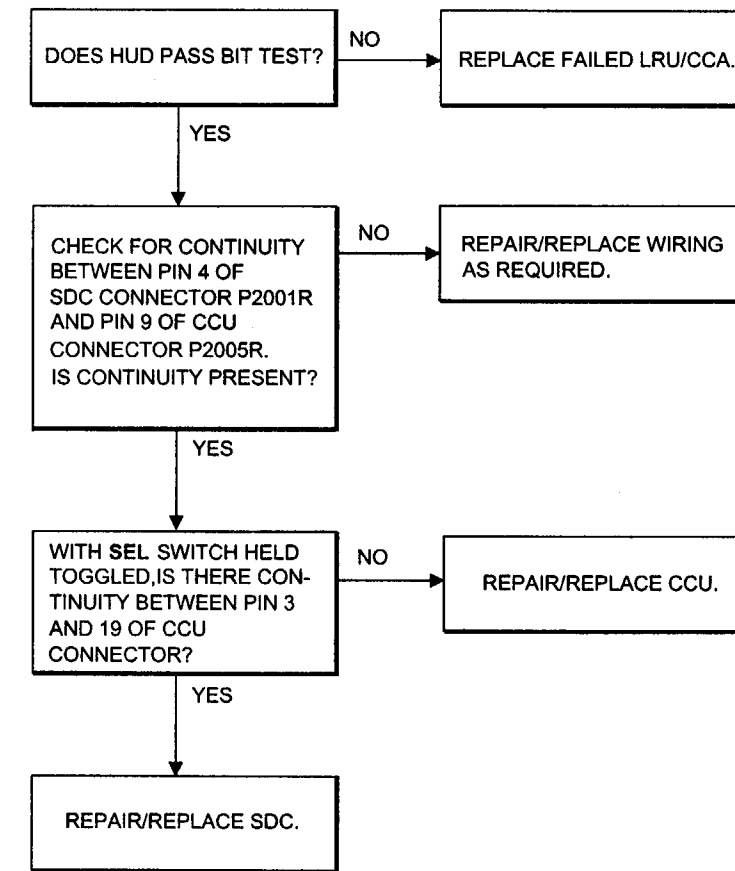

END OF TASK

FAULT ISOLATION PROCEDURE

Personnel Required:
Avionics Mechanic

References:
TM 55-1520-240-23
TM 11-5855-300-23&P

Equipment Condition:
TM 55-1520-240-23:
Battery Connected
Electrical Power On

INITIAL SETUP

Applicable Configurations:
All

Tools:

Electronic Equipment Tool Kit,
NSN 5180-00-064-5178
Multimeter

Materials:

None

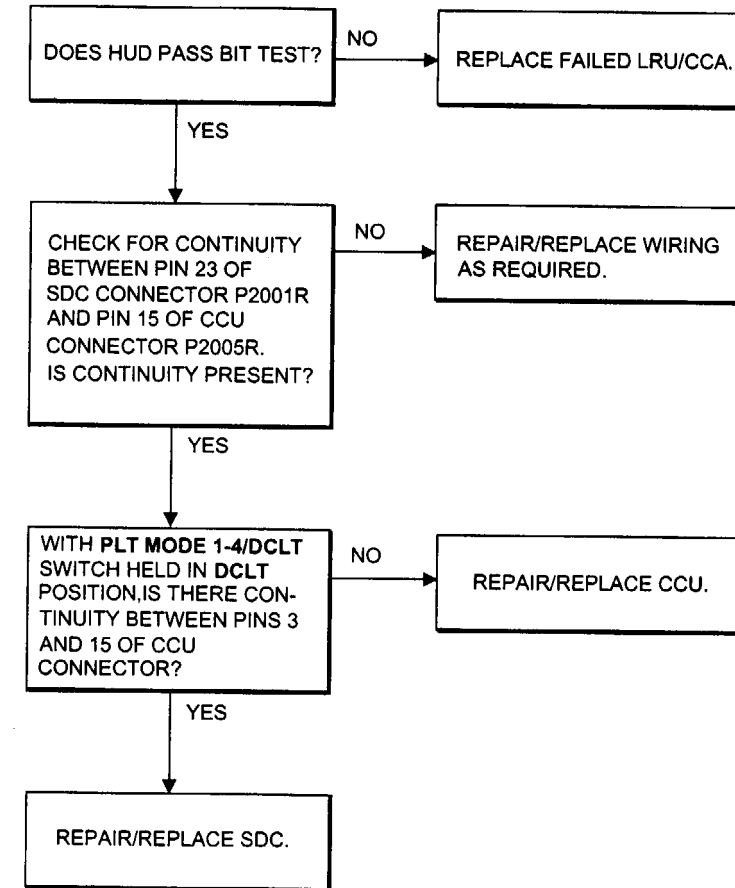
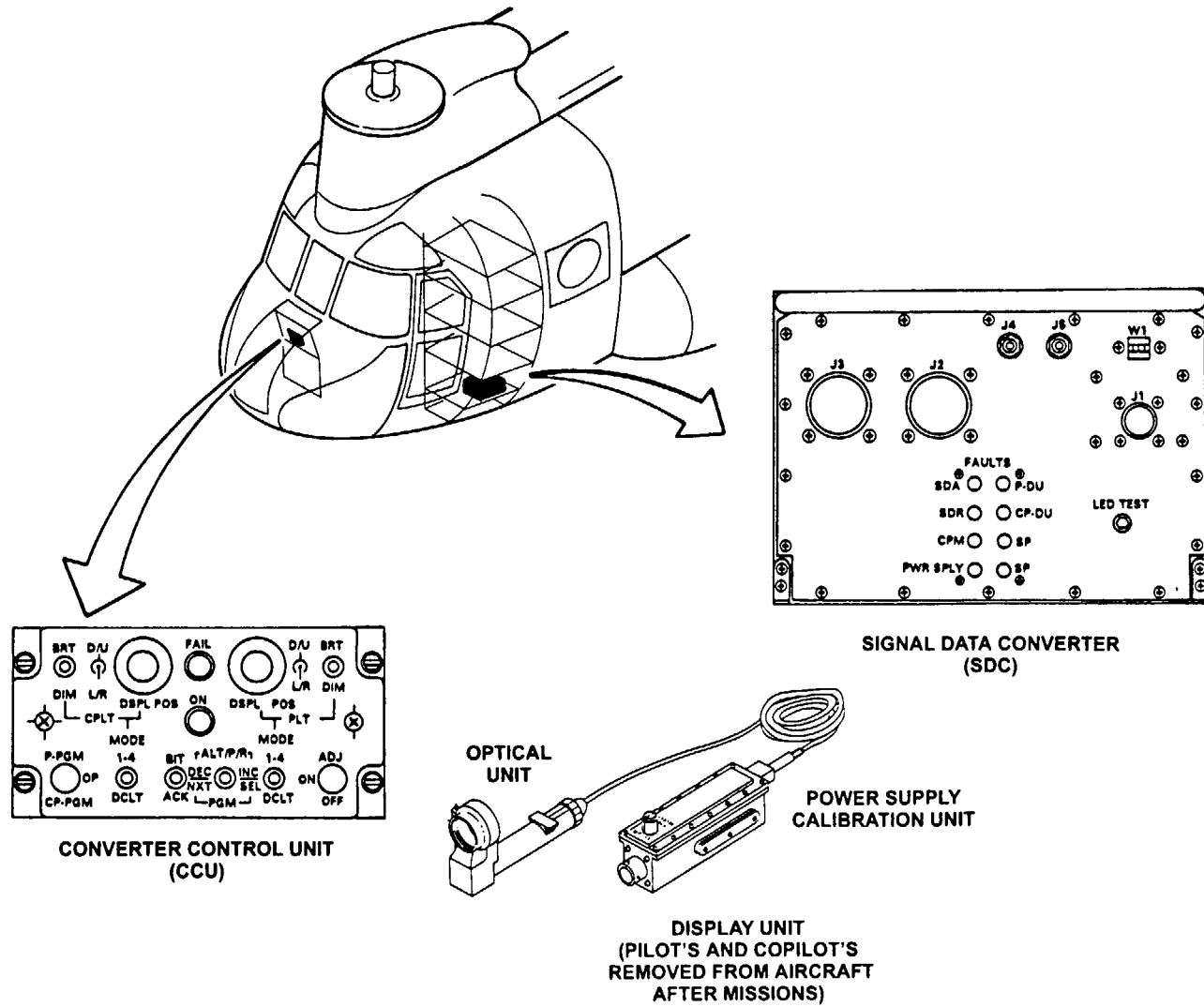

FAULT ISOLATION PROCEDURE

Personnel Required:
Avionics Mechanic

INITIAL SETUP

Applicable Configurations:
All

References:
TM 55-1520-240-23
TM 11-5855-300-23&P

Tools:

Electronic Equipment Tool Kit,
NSN 5180-00-064-5178
Multimeter

Equipment Condition:
TM 55-1520-240-23:
Battery Connected
Electrical Power On

Materials:

None

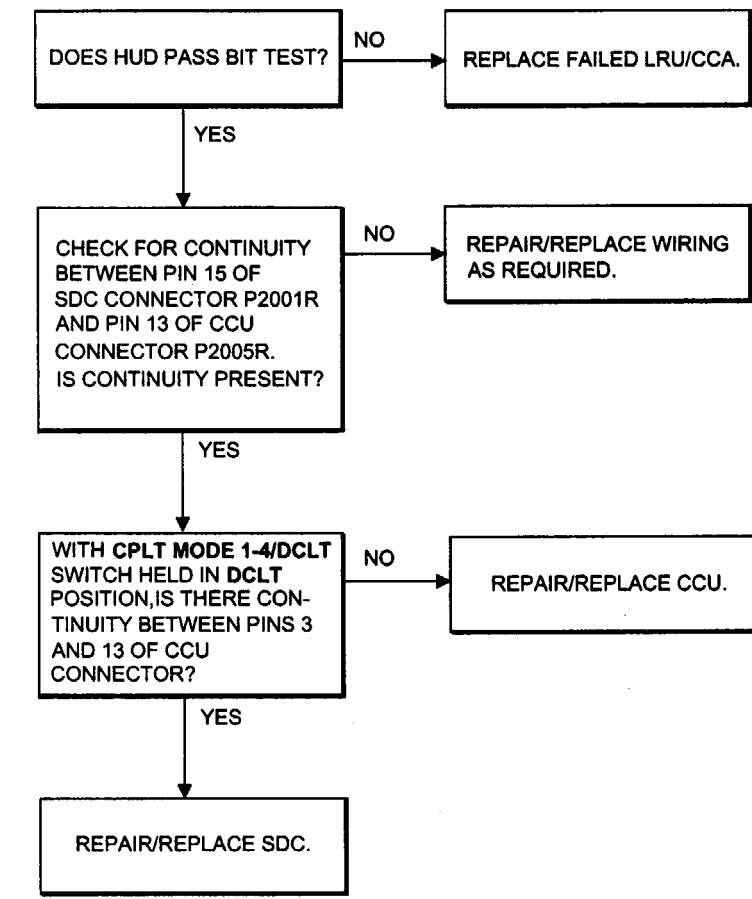
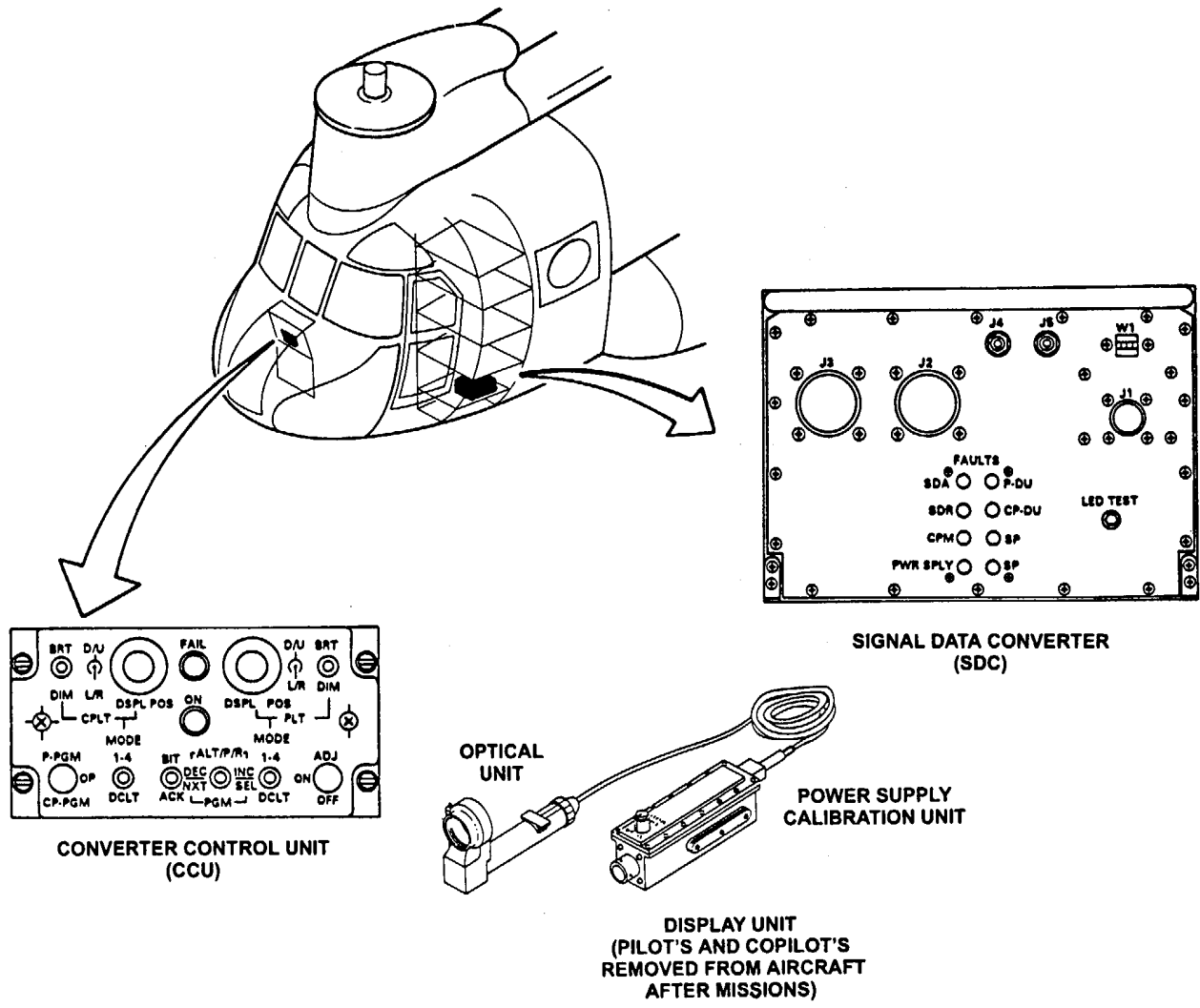

END OF TASK

FAULT ISOLATION PROCEDURE

Personnel Required:
Avionics Mechanic

References:
TM 55-1520-240-23
TM 11-5855-300-23&P

Equipment Condition:
TM 55-1520-240-23:
Battery Connected
Electrical Power On

INITIAL SETUP

Applicable Configurations:

All

Tools:

Electronic Equipment Tool Kit,
NSN 5180-00-064-5178
Multimeter

Materials:

None

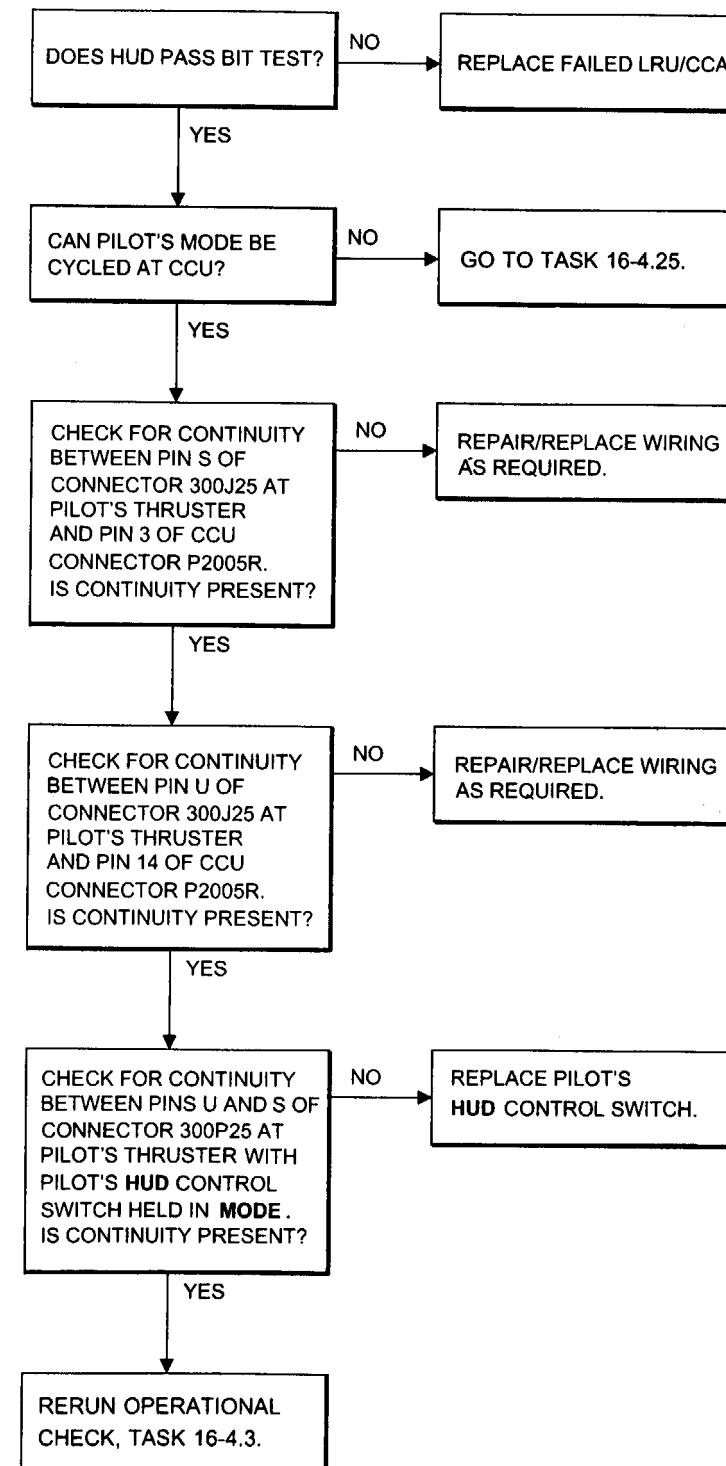
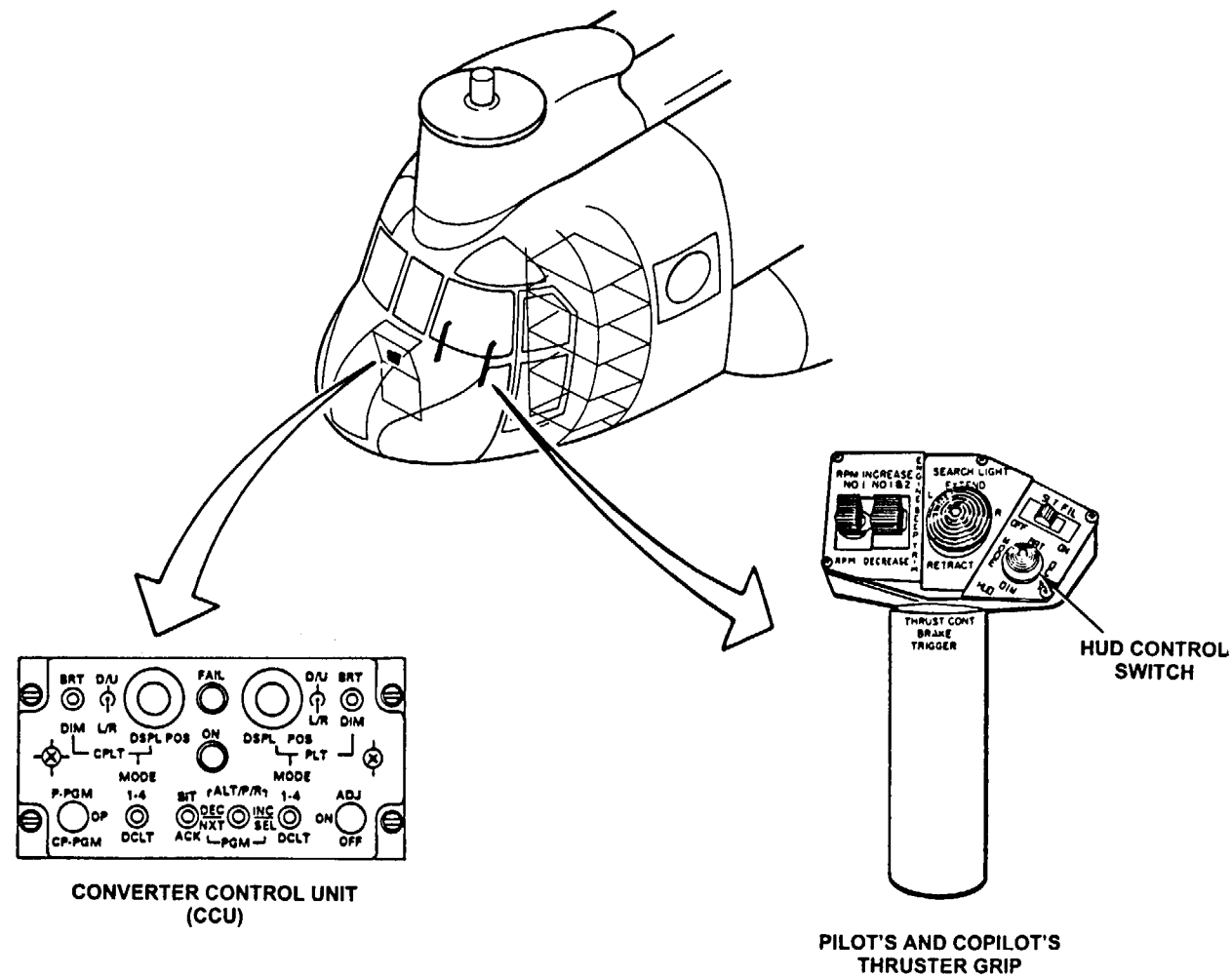

END OF TASK

16-4.14 CANNOT CYCLE THROUGH DECLUTTER AT PILOT'S THRUSTER GRIP

FAULT ISOLATION PROCEDURE

Personnel Required:
Avionics Mechanic

INITIAL SETUP

Applicable Configurations:

All

References:

TM 55-1520-240-23
TM 11-5855-300-23&P

Tools:

Electronic Equipment Tool Kit,
NSN 5180-00-064-5178
Multimeter

Equipment Condition:

TM 55-1520-240-23:
Battery Connected
Electrical Power On

Materials:

None

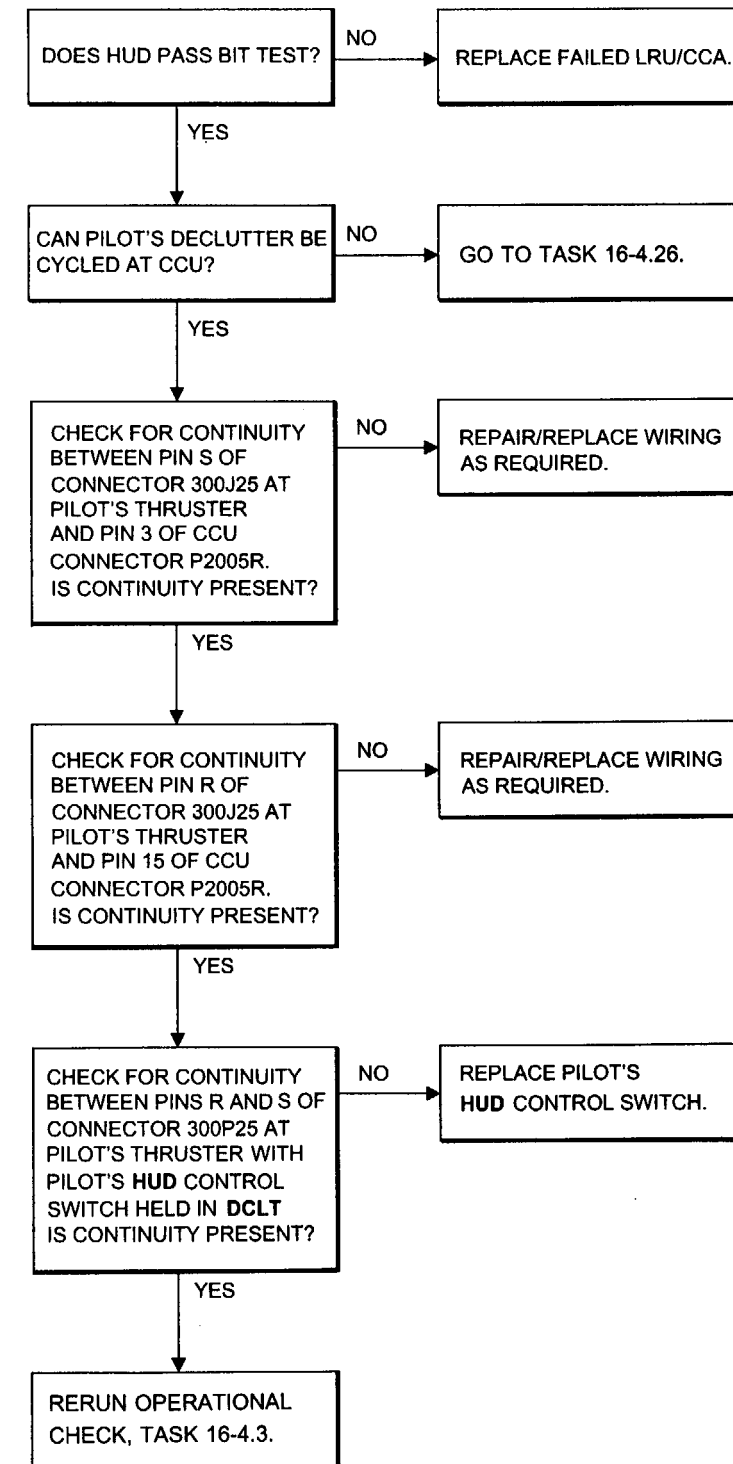
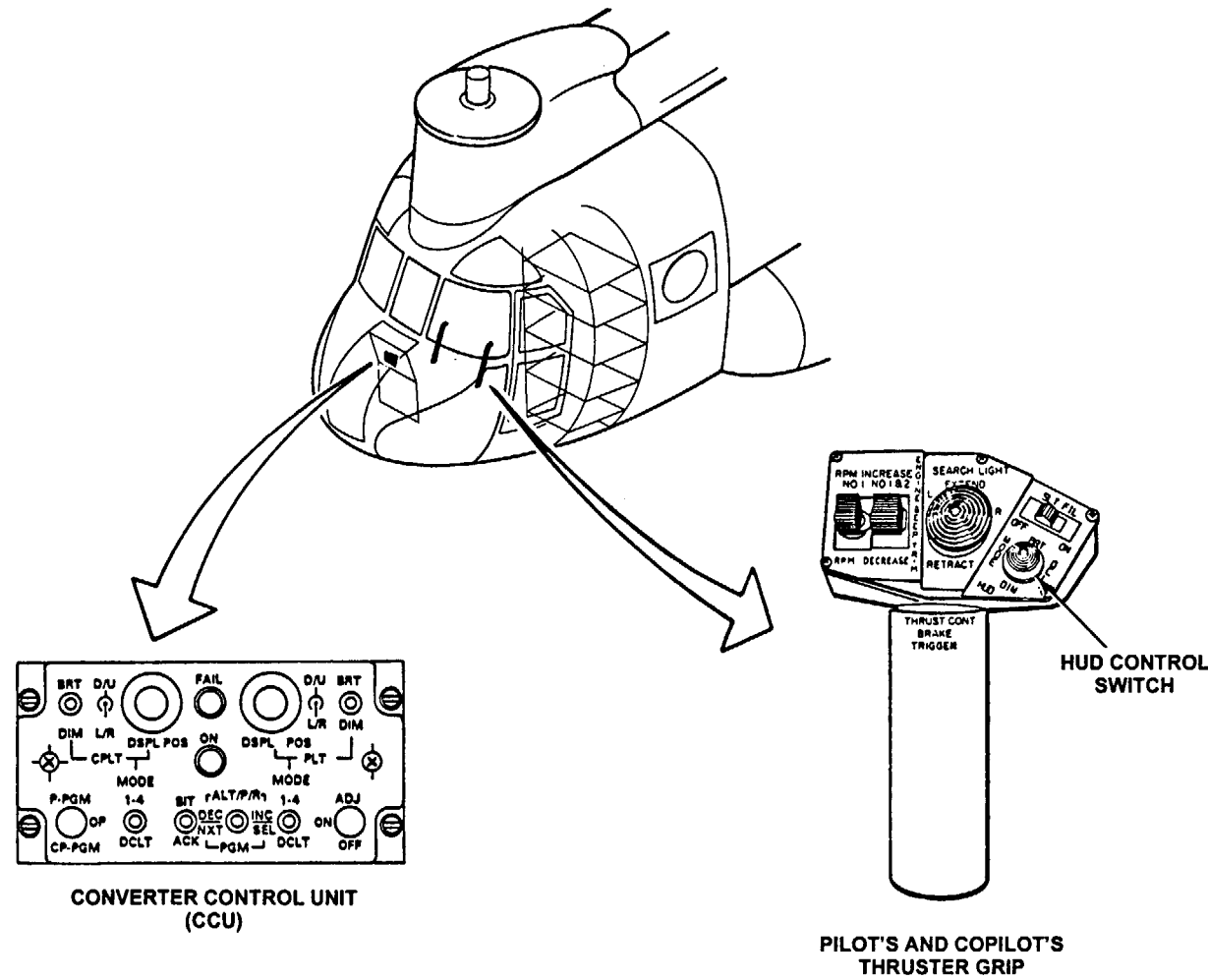

END OF TASK

FAULT ISOLATION PROCEDURE

Personnel Required:
Avionics Mechanic

References:
TM 55-1520-240-23
TM 11-5855-300-23&P

Equipment Condition:
TM 55-1520-240-23:
Battery Connected
Electrical Power On

INITIAL SETUP

Applicable Configurations:

All

Tools:

Electronic Equipment Tool Kit,
NSN 5180-00-064-5178
Multimeter

Materials:

None

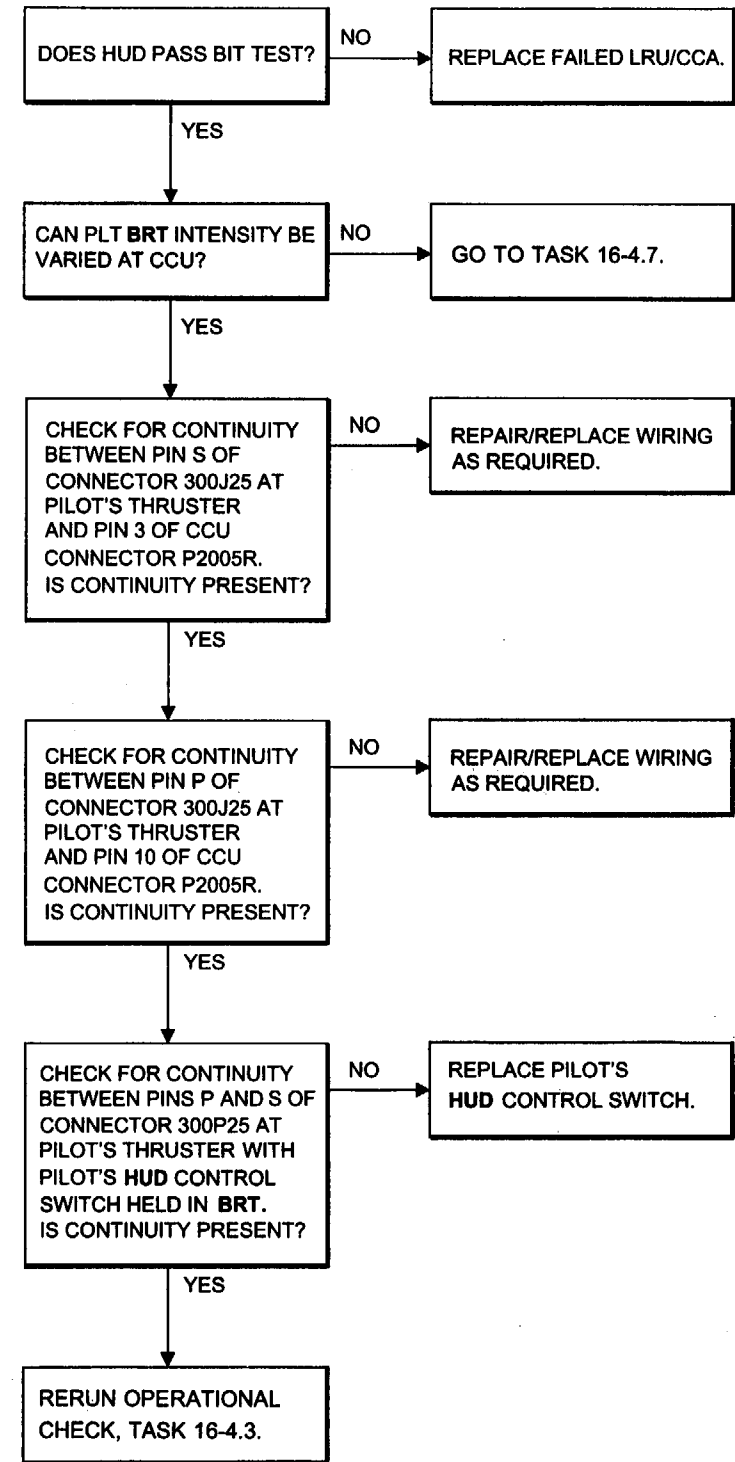
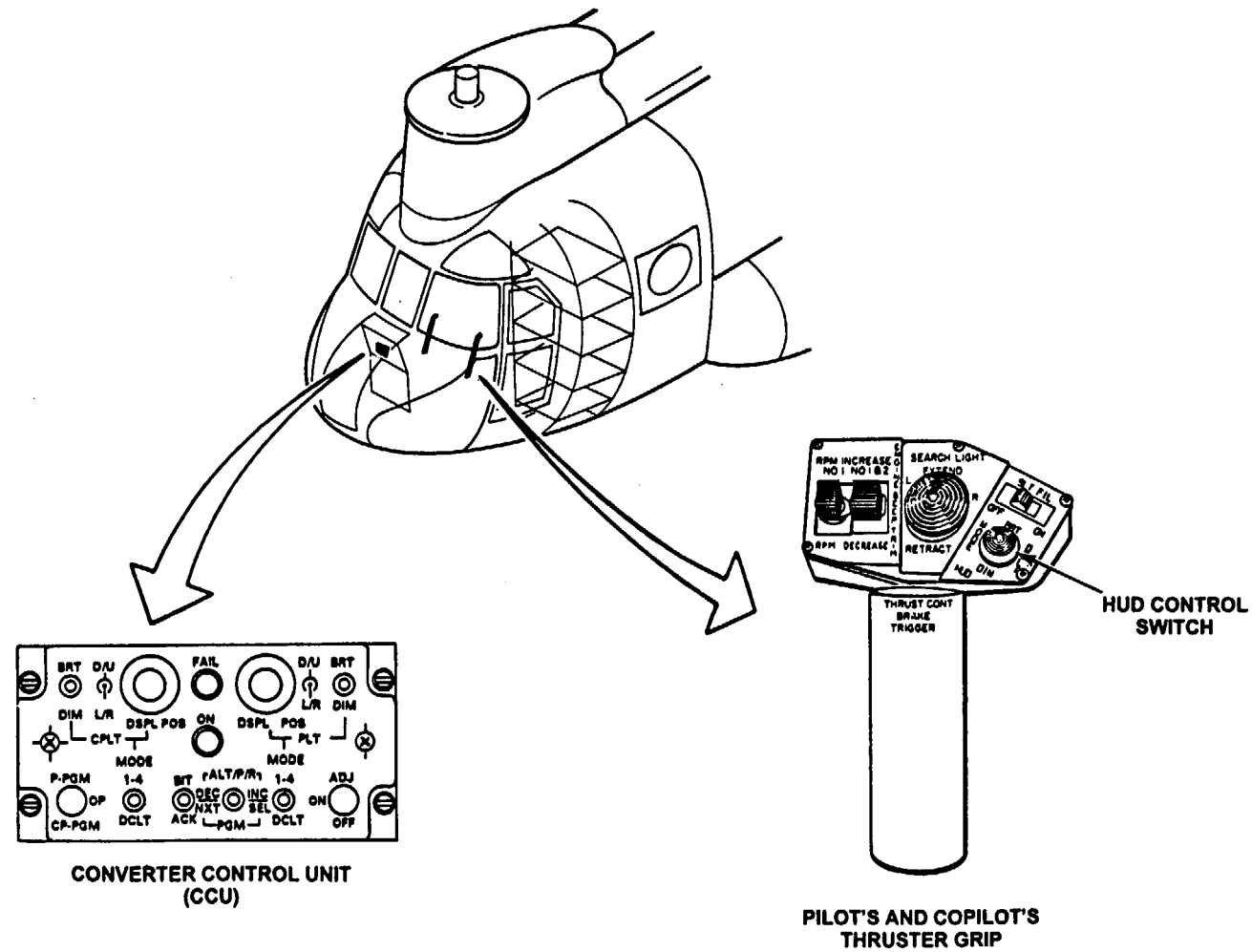

END OF TASK

16-4.16 PILOT'S DIM CONTROL ON THRUSTER DOES NOT VARY DISPLAY INTENSITY

FAULT ISOLATION PROCEDURE

Personnel Required:
Avionics Mechanic

INITIAL SETUP

Applicable Configurations:

All

References:

TM 55-1520-240-23
TM 11-5855-300-23&P

Tools:

Electronic Equipment Tool Kit,
NSN 5180-00-064-5178
Multimeter

Equipment Condition:

TM 55-1520-240-23:
Battery Connected
Electrical Power On

Materials:

None

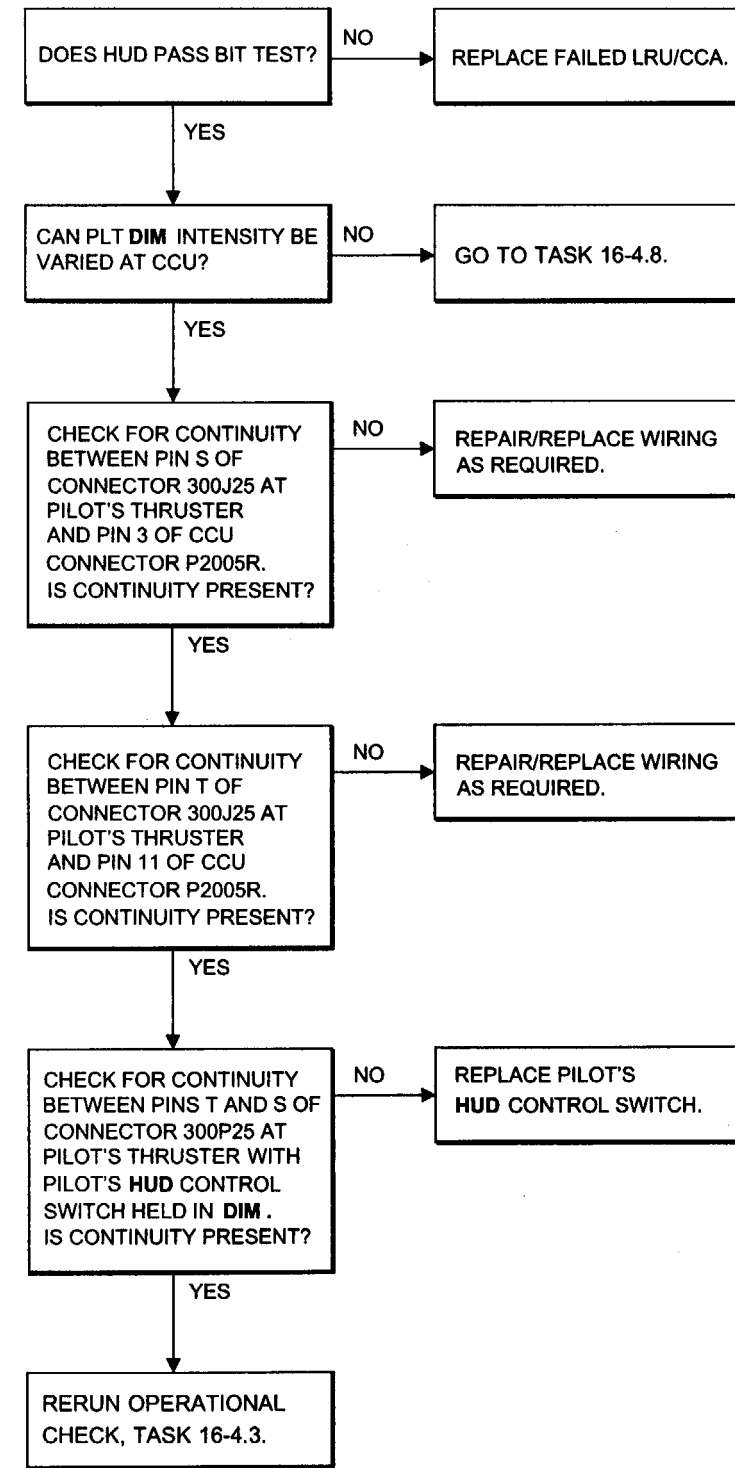
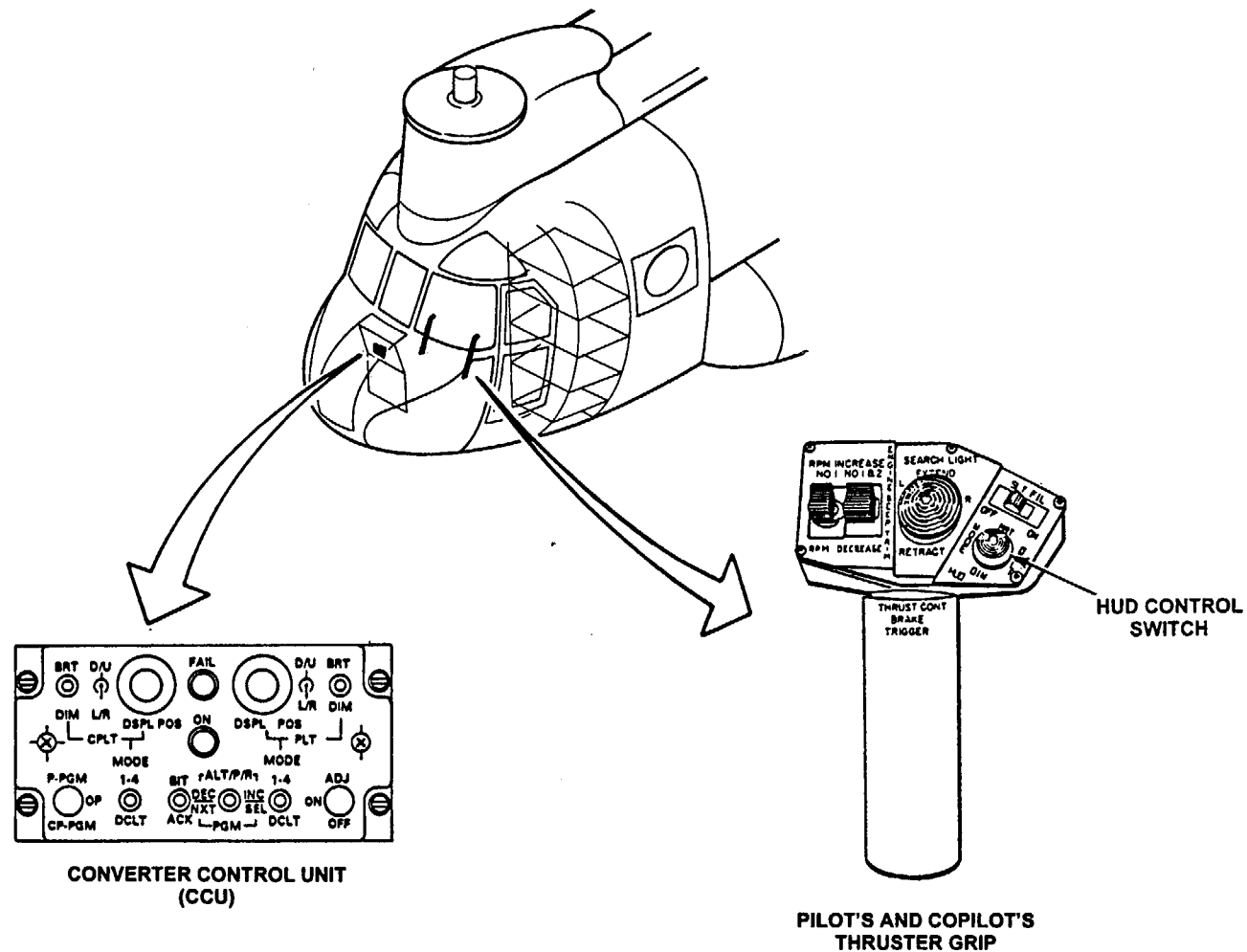

END OF TASK

FAULT ISOLATION PROCEDURE

Personnel Required:
Avionics Mechanic

References:
TM 55-1520-240-23
TM 11-5855-300-23&P

Equipment Condition:
TM 55-1520-240-23:
Battery Connected
Electrical Power On

INITIAL SETUP

Applicable Configurations:
All

Tools:

Electronic Equipment Tool Kit,
NSN 5180-00-064-5178
Multimeter

Materials:

None

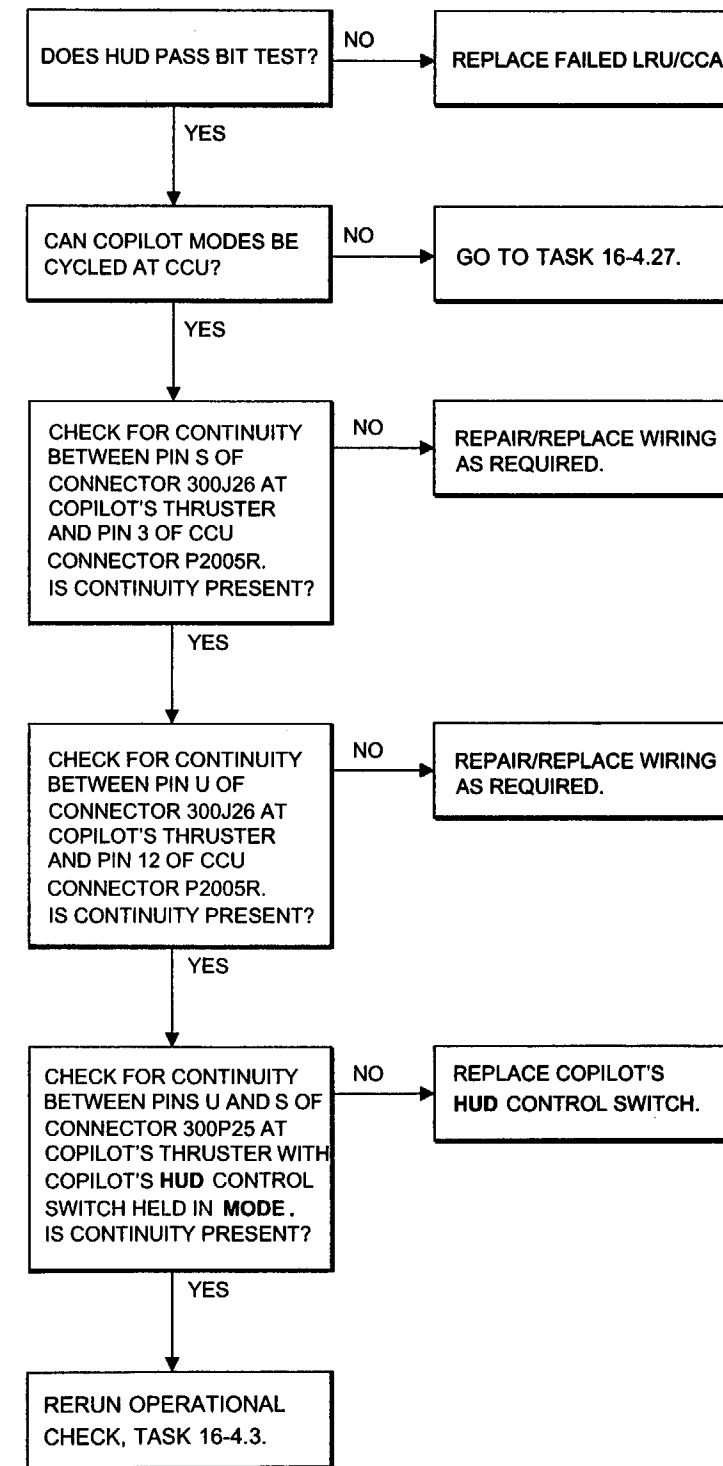
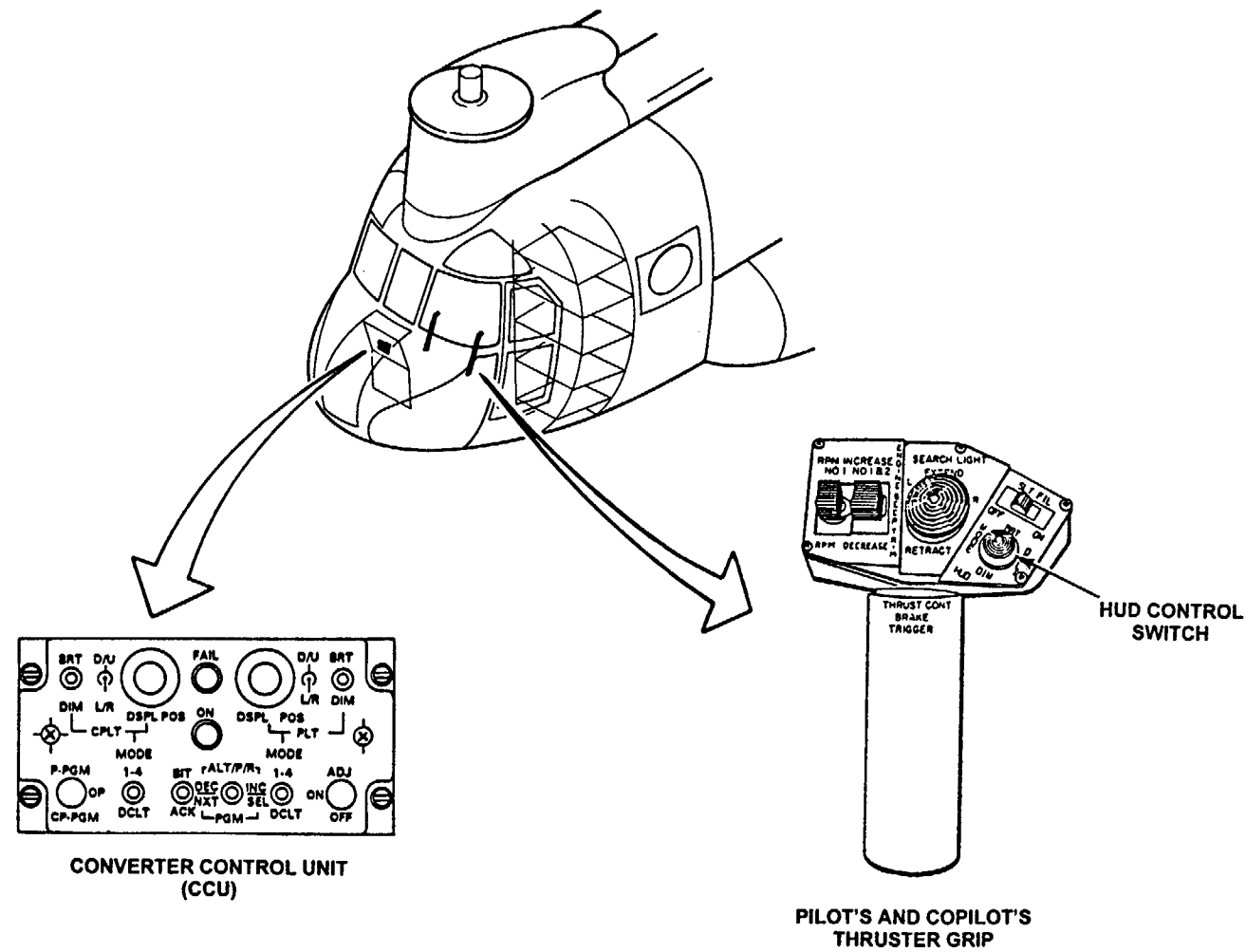

END OF TASK

16-4.18 CANNOT CYCLE THROUGH DECLUTTER AT COPILOT'S THRUSTER GRIP

16-4.18

FAULT ISOLATION PROCEDURE

Personnel Required:
Avionics Mechanic

INITIAL SETUP

Applicable Configurations:

All

References:

TM 55-1520-240-23
TM 11-5855-300-23&P

Tools:

Electronic Equipment Tool Kit,
NSN 5180-00-064-5178
Multimeter

Equipment Condition:

TM 55-1520-240-23:
Battery Connected
Electrical Power On

Materials:

None

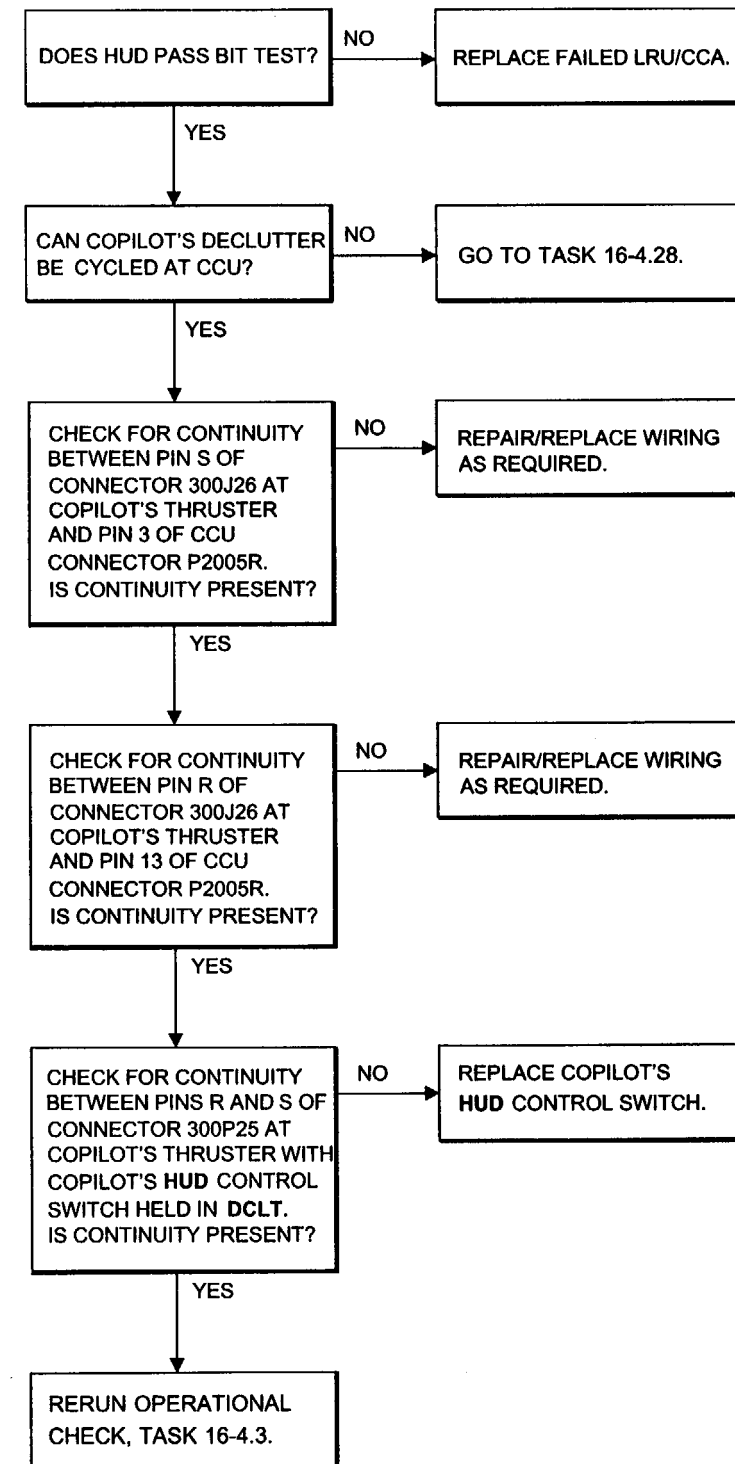
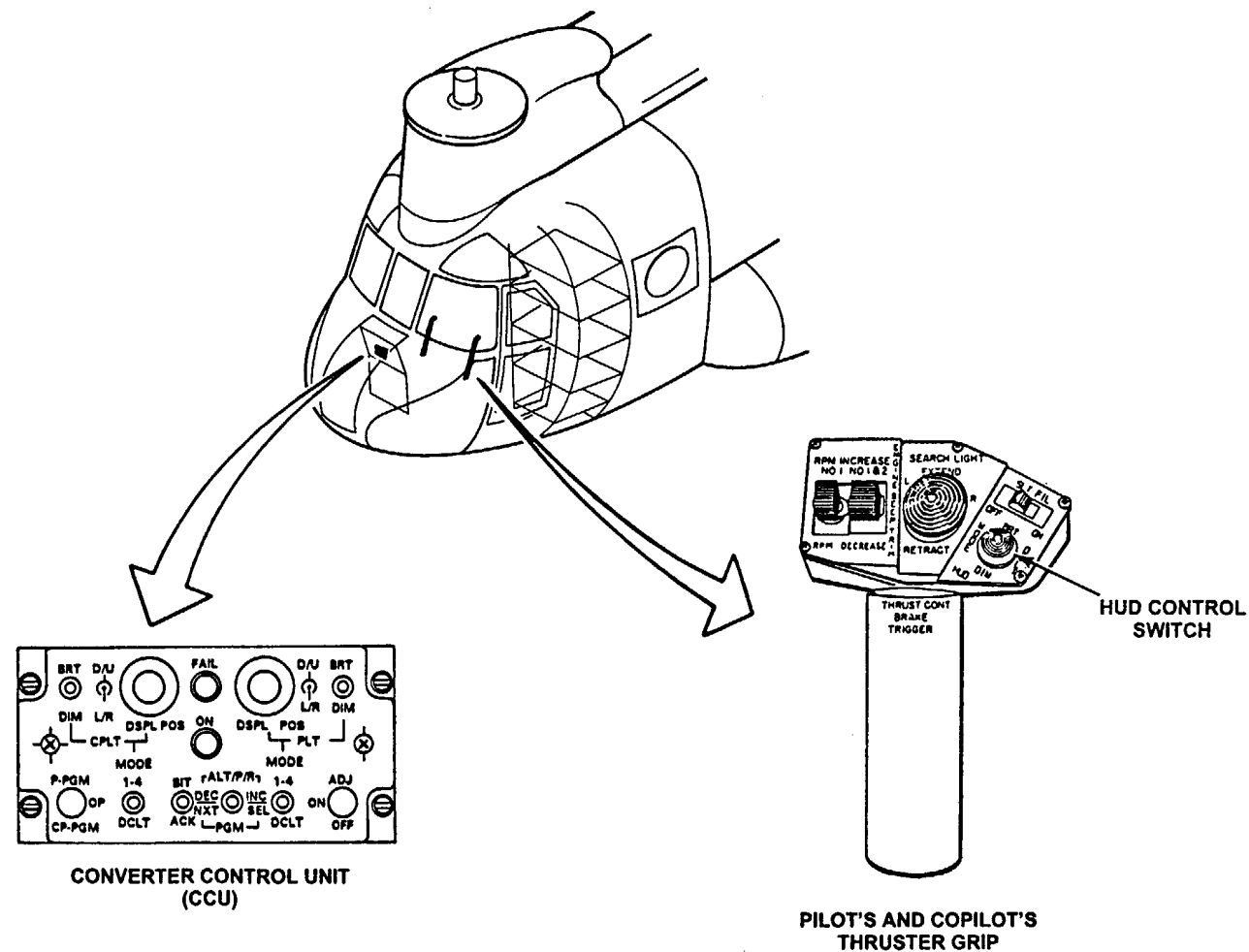

END OF TASK

FAULT ISOLATION PROCEDURE

Personnel Required:
Avionics Mechanic

References:
TM 55-1520-240-23
TM 11-5855-300-23&P

Equipment Condition:
TM 55-1520-240-23:
Battery Connected
Electrical Power On

INITIAL SETUP

Applicable Configurations:

All

Tools:

Electronic Equipment Tool Kit,
NSN 5180-00-064-5178
Multimeter

Materials:

None

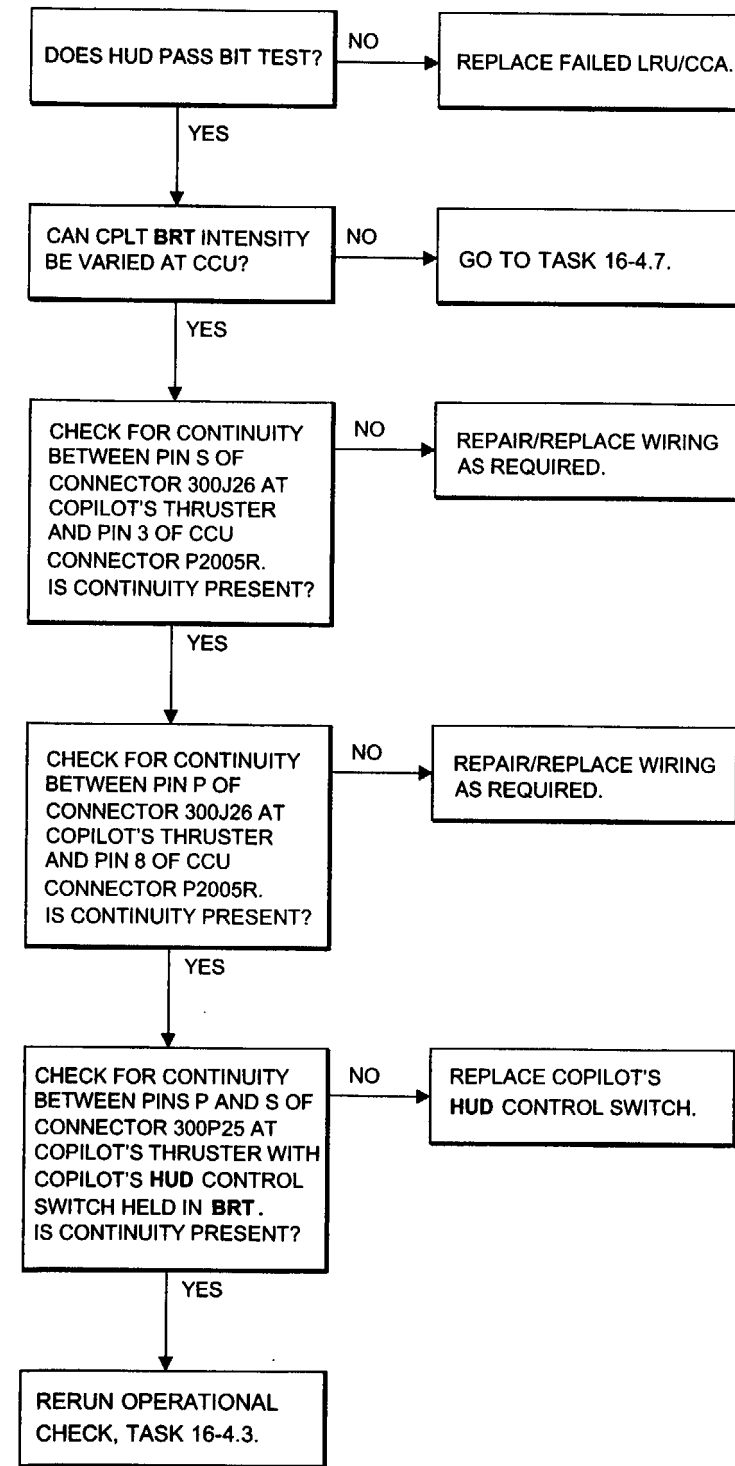
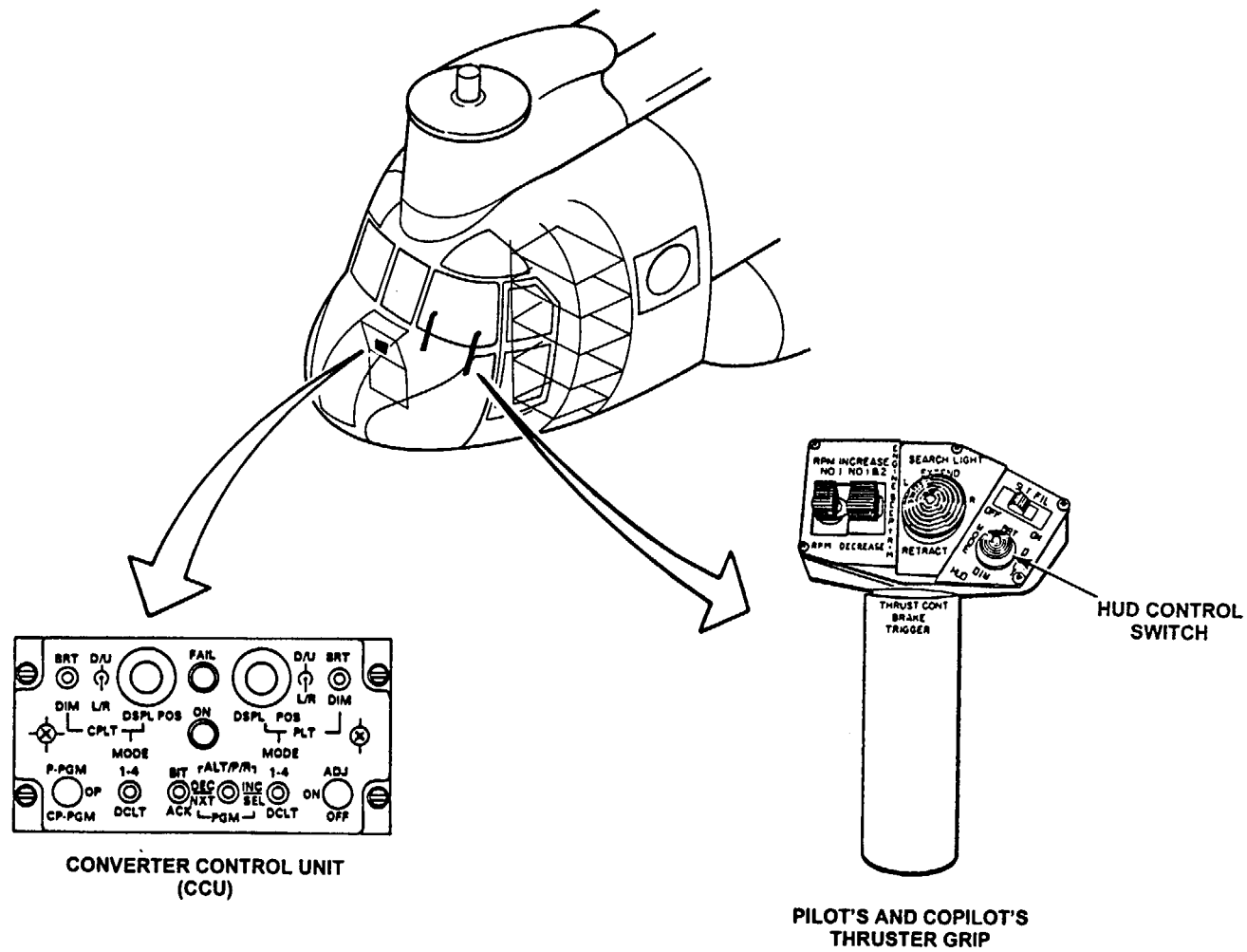

END OF TASK

16-4.20 COPILOT'S DIM CONTROL ON THRUSTER DOES NOT VARY DISPLAY INTENSITY

16-4.20

FAULT ISOLATION PROCEDURE

Personnel Required:
Avionics Mechanic

INITIAL SETUP

Applicable Configurations:

All

References:

TM 55-1520-240-23
TM 11-5855-300-23&P

Tools:

Electronic Equipment Tool Kit,
NSN 5180-00-064-5178
Multimeter

Equipment Condition:

TM 55-1520-240-23:
Battery Connected
Electrical Power On

Materials:

None

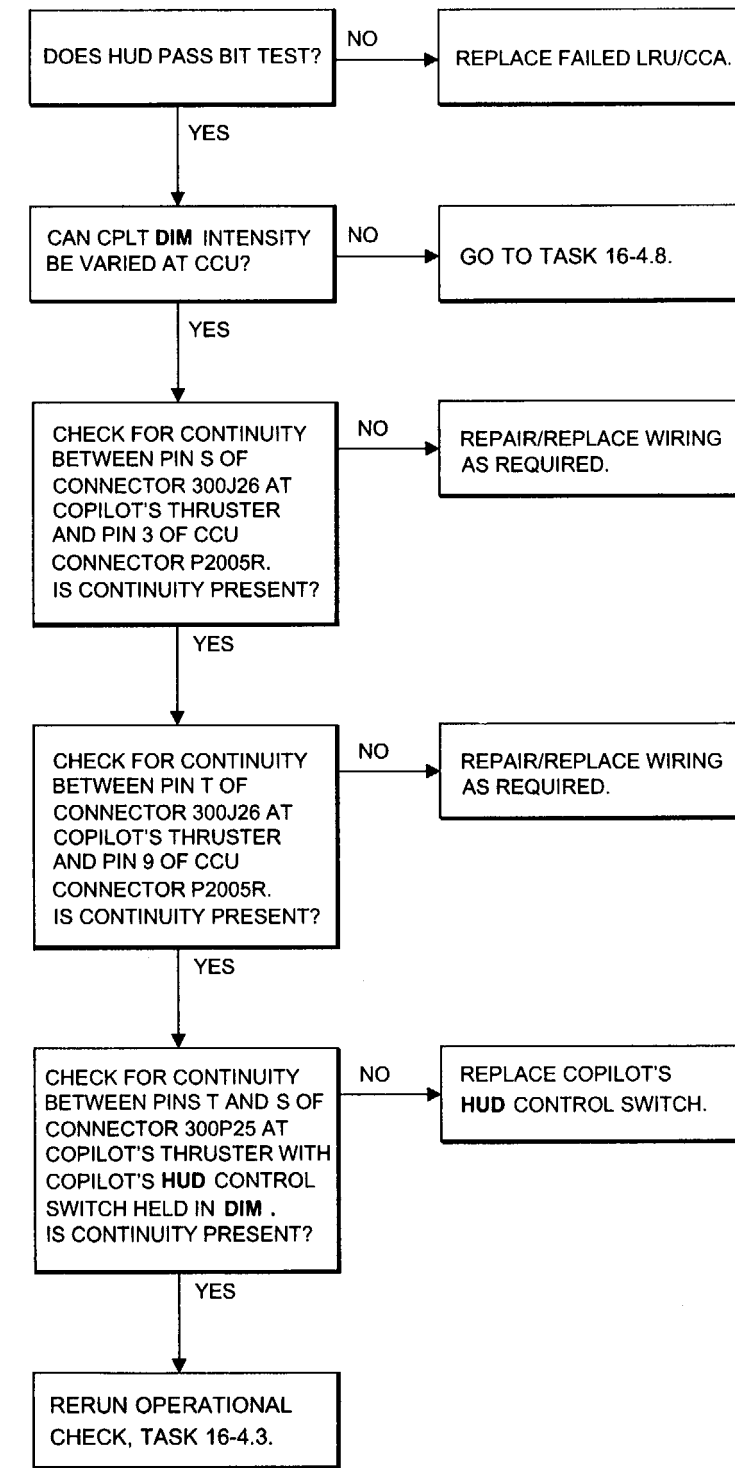
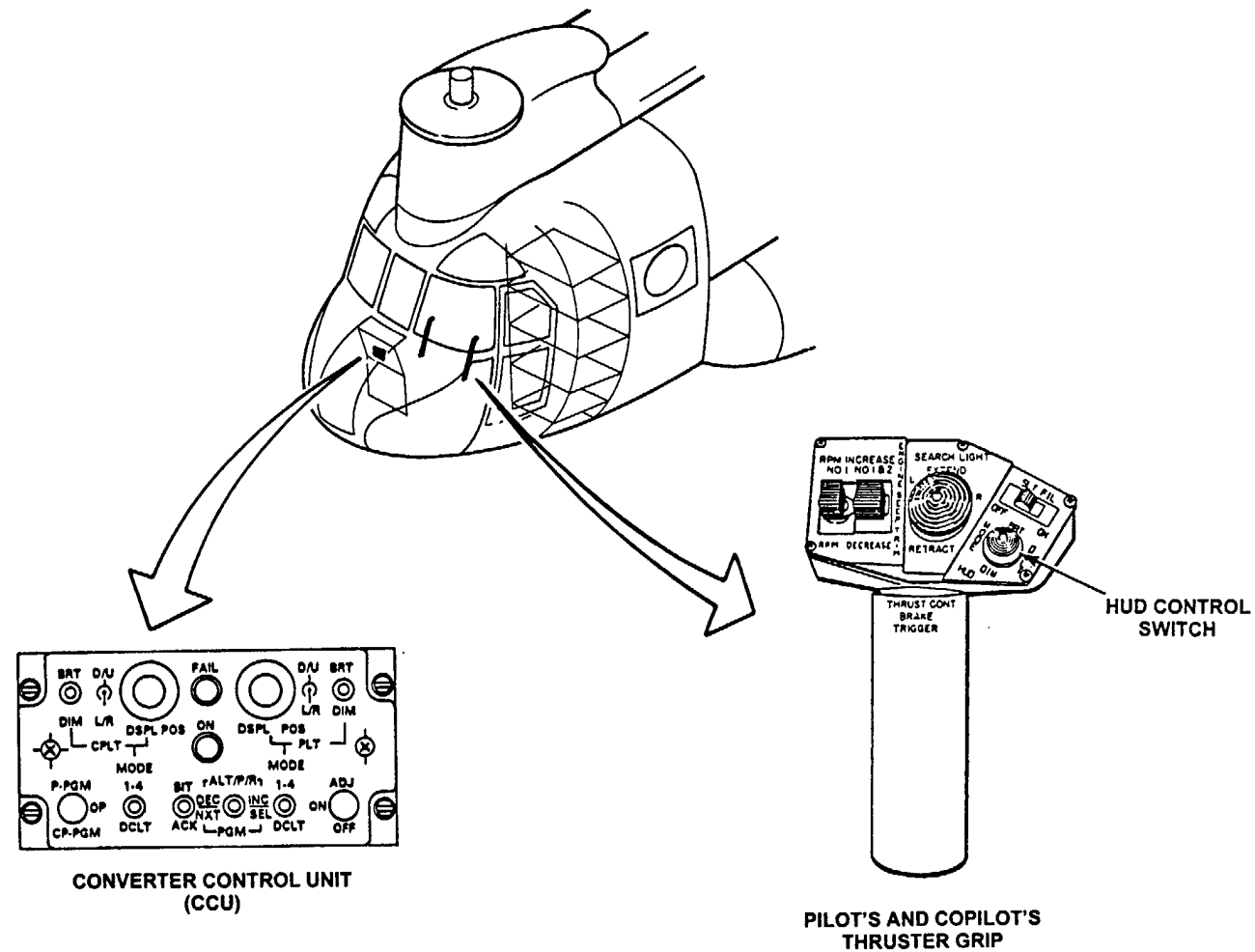

END OF TASK

FAULT ISOLATION PROCEDURE

Personnel Required:
Avionics Mechanic

References:
TM 55-1520-240-23
TM 11-5855-300-23&P

Equipment Condition:
TM 55-1520-240-23:
Battery Connected
Electrical Power On

INITIAL SETUP

Applicable Configurations:

All

Tools:

Electronic Equipment Tool Kit,
NSN 5180-00-064-5178
Multimeter

Materials:

None

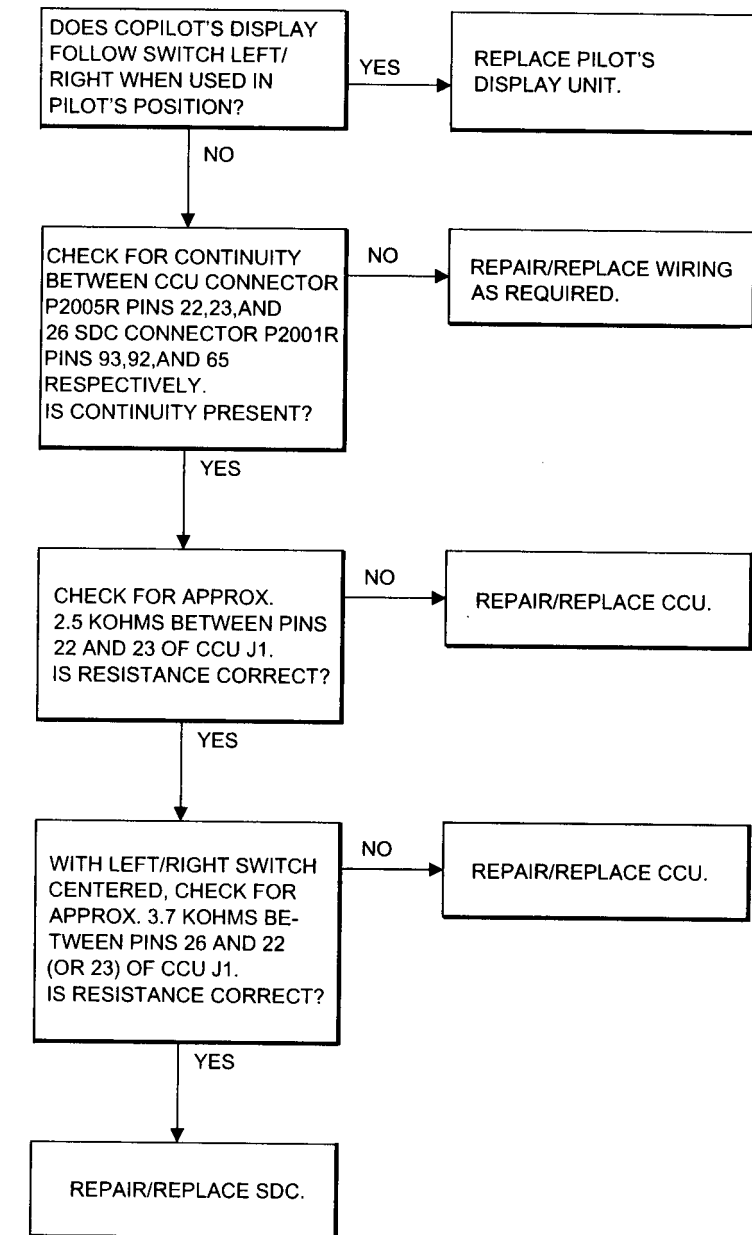
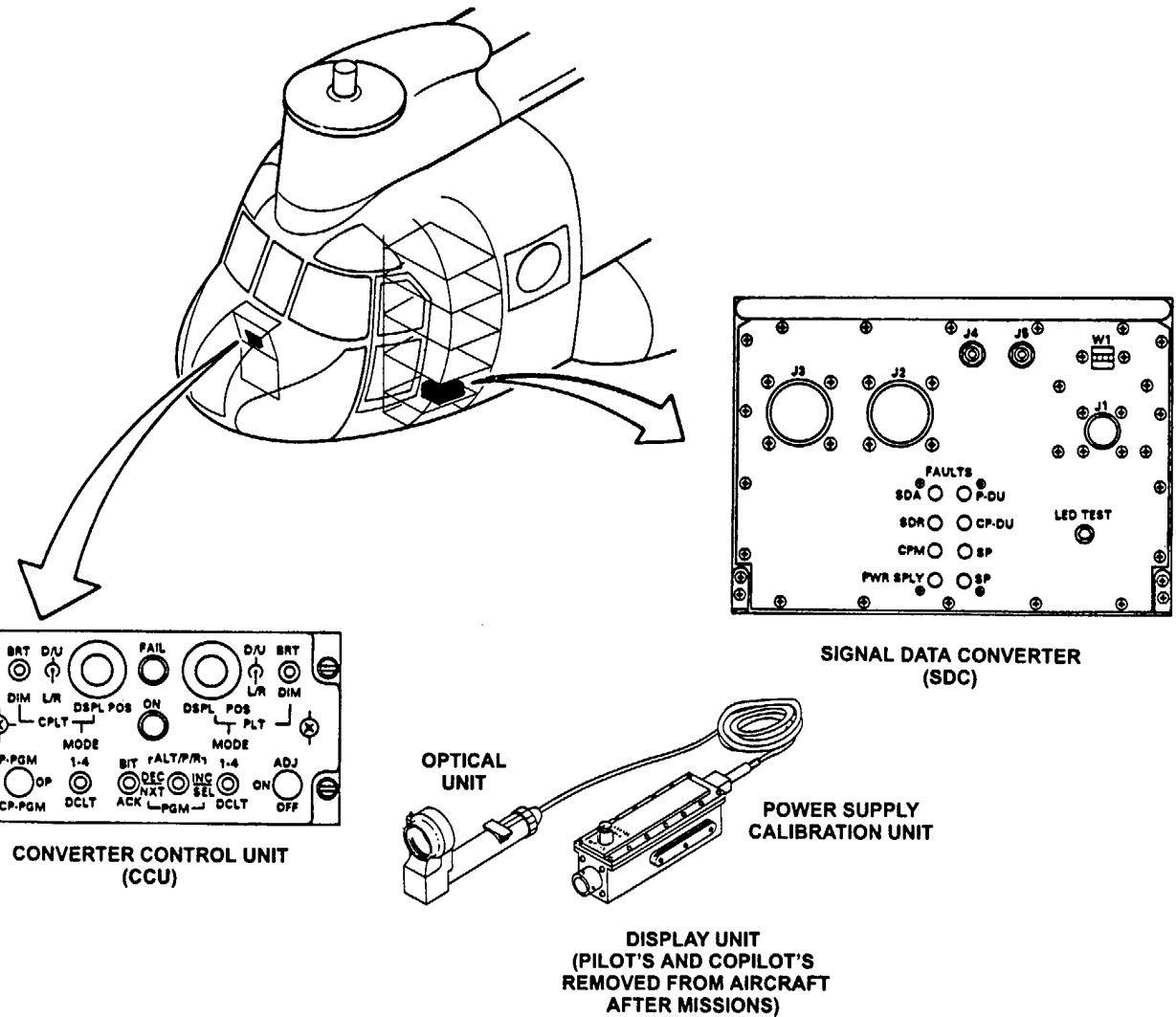

FAULT ISOLATION PROCEDURE

Personnel Required:
Avionics Mechanic

INITIAL SETUP

Applicable Configurations:

All

References:

TM 55-1520-240-23
TM 11-5855-300-23&P

Tools:

Electronic Equipment Tool Kit,
NSN 5180-00-064-5178
Multimeter

Equipment Condition:

TM 55-1520-240-23:
Battery Connected
Electrical Power On

Materials:

None

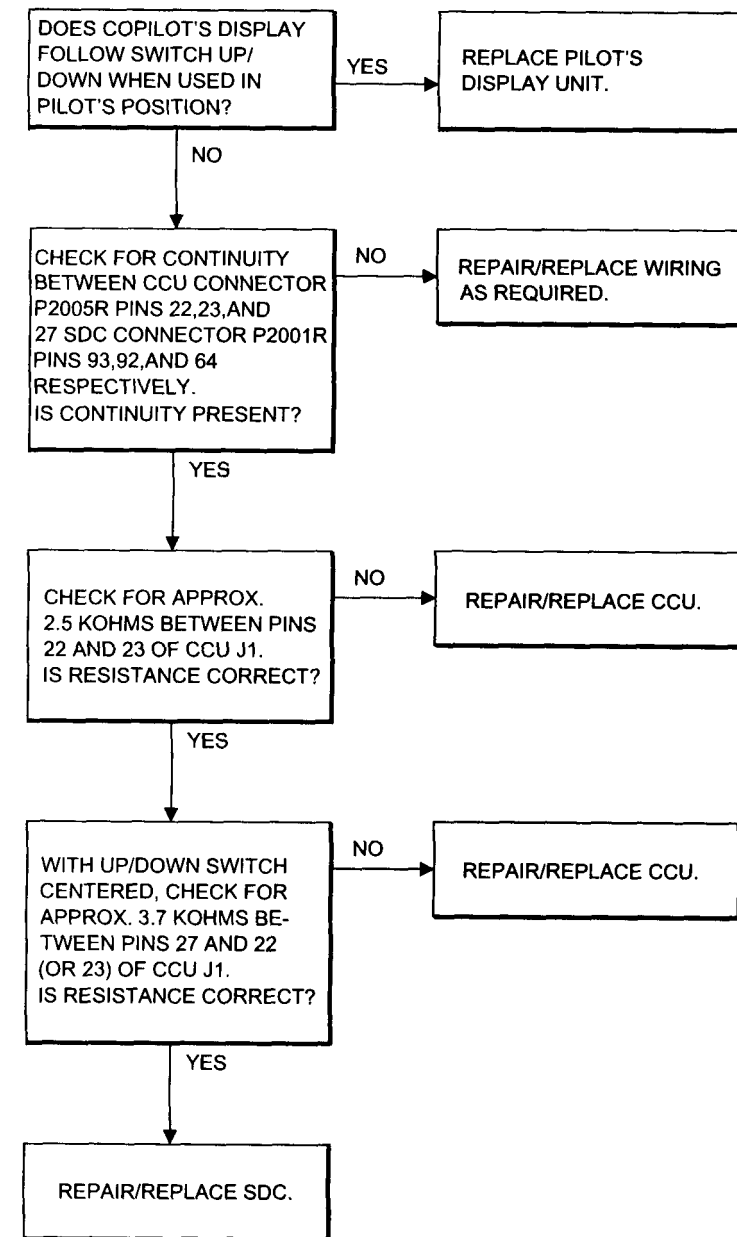
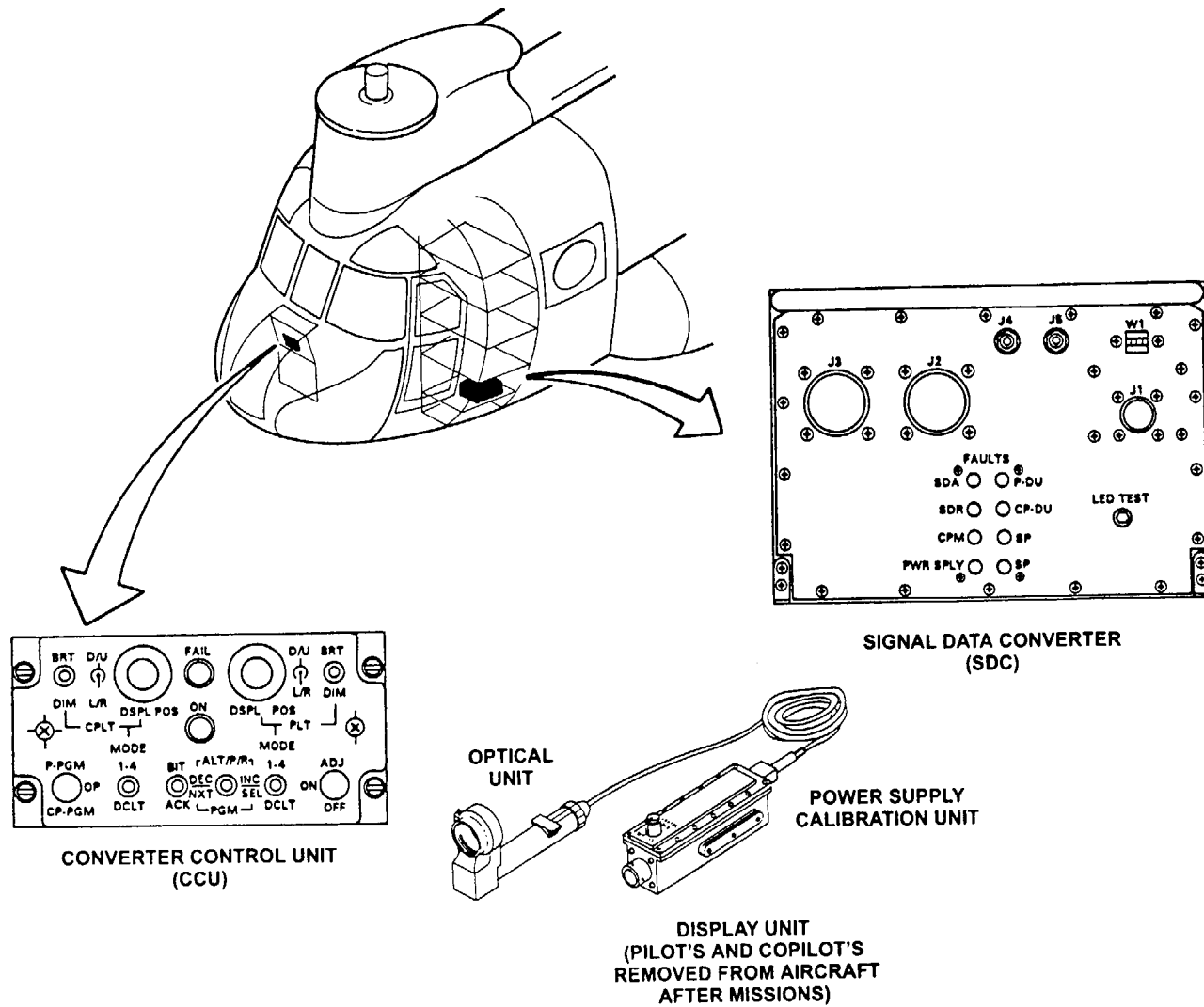

END OF TASK

FAULT ISOLATION PROCEDURE

Personnel Required:
Avionics Mechanic

References:
TM 55-1520-240-23
TM 11-5855-300-23&P

Equipment Condition:
TM 55-1520-240-23:
Battery Connected
Electrical Power On

INITIAL SETUP

Applicable Configurations:

All

Tools:

Electronic Equipment Tool Kit,
NSN 5180-00-064-5178
Multimeter

Materials:

None

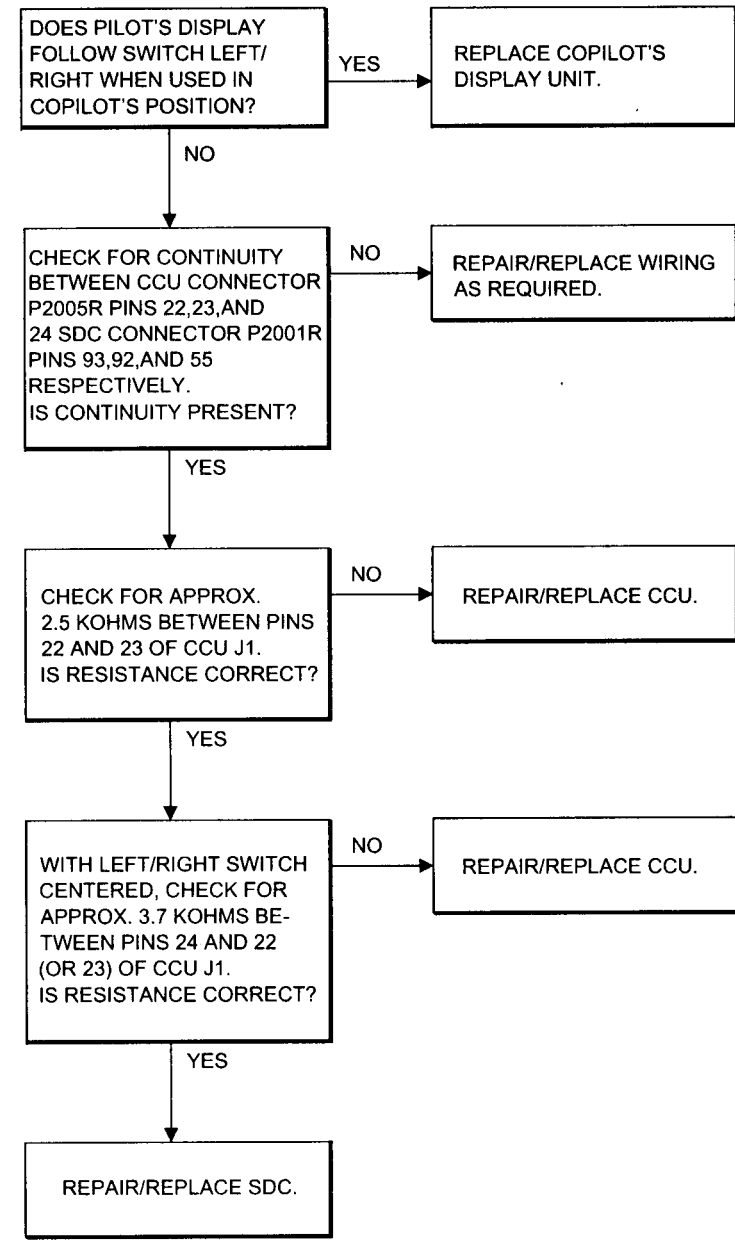
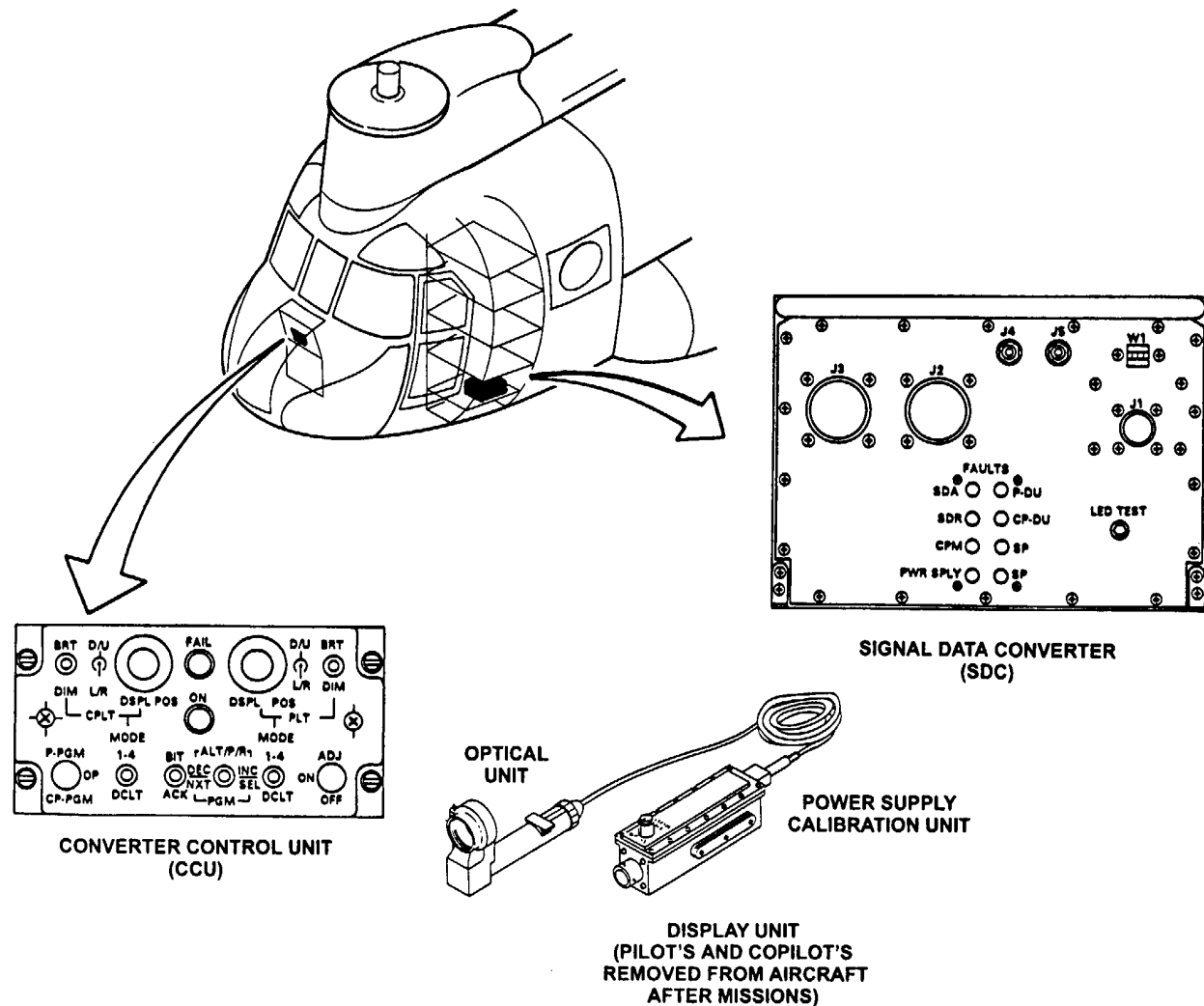

END OF TASK

FAULT ISOLATION PROCEDURE

Personnel Required:
Avionics Mechanic

INITIAL SETUP

Applicable Configurations:

All

References:

TM 55-1520-240-23
TM 11-5855-300-23&P

Tools:

Electronic Equipment Tool Kit,
NSN 5180-00-064-5178
Multimeter

Equipment Condition:

TM 55-1520-240-23:
Battery Connected
Electrical Power On

Materials:

None

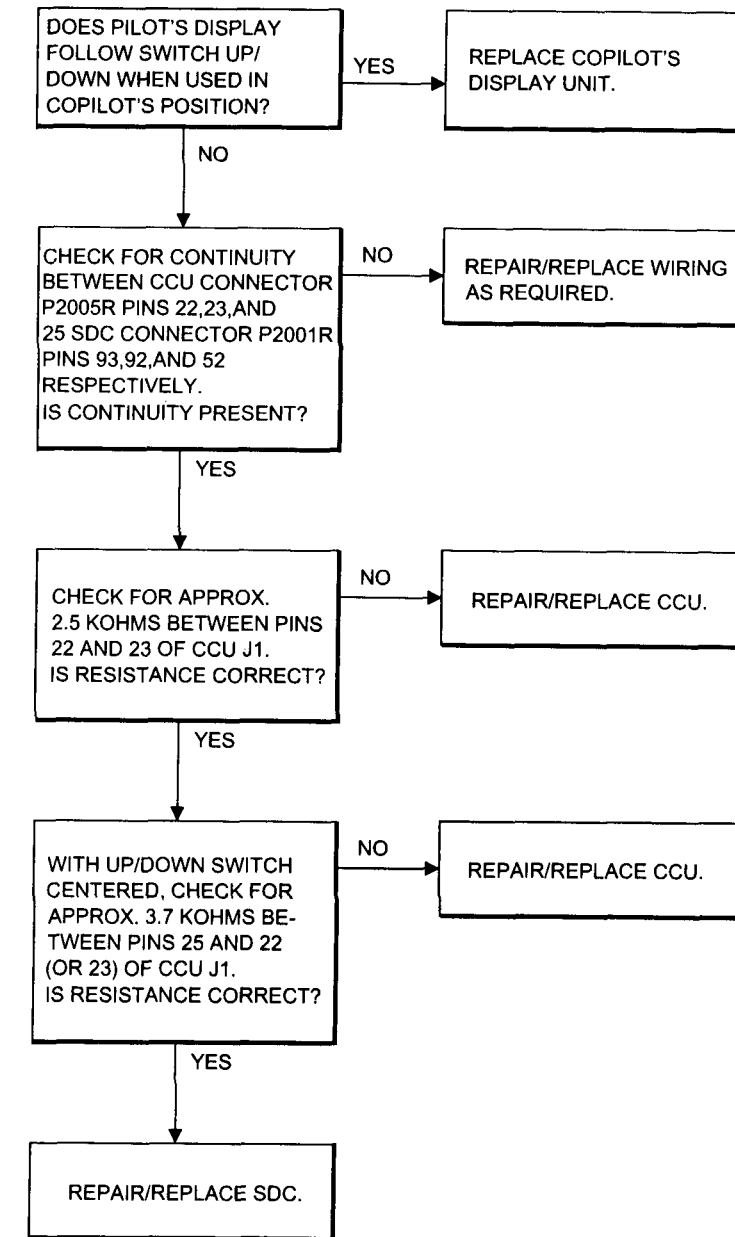
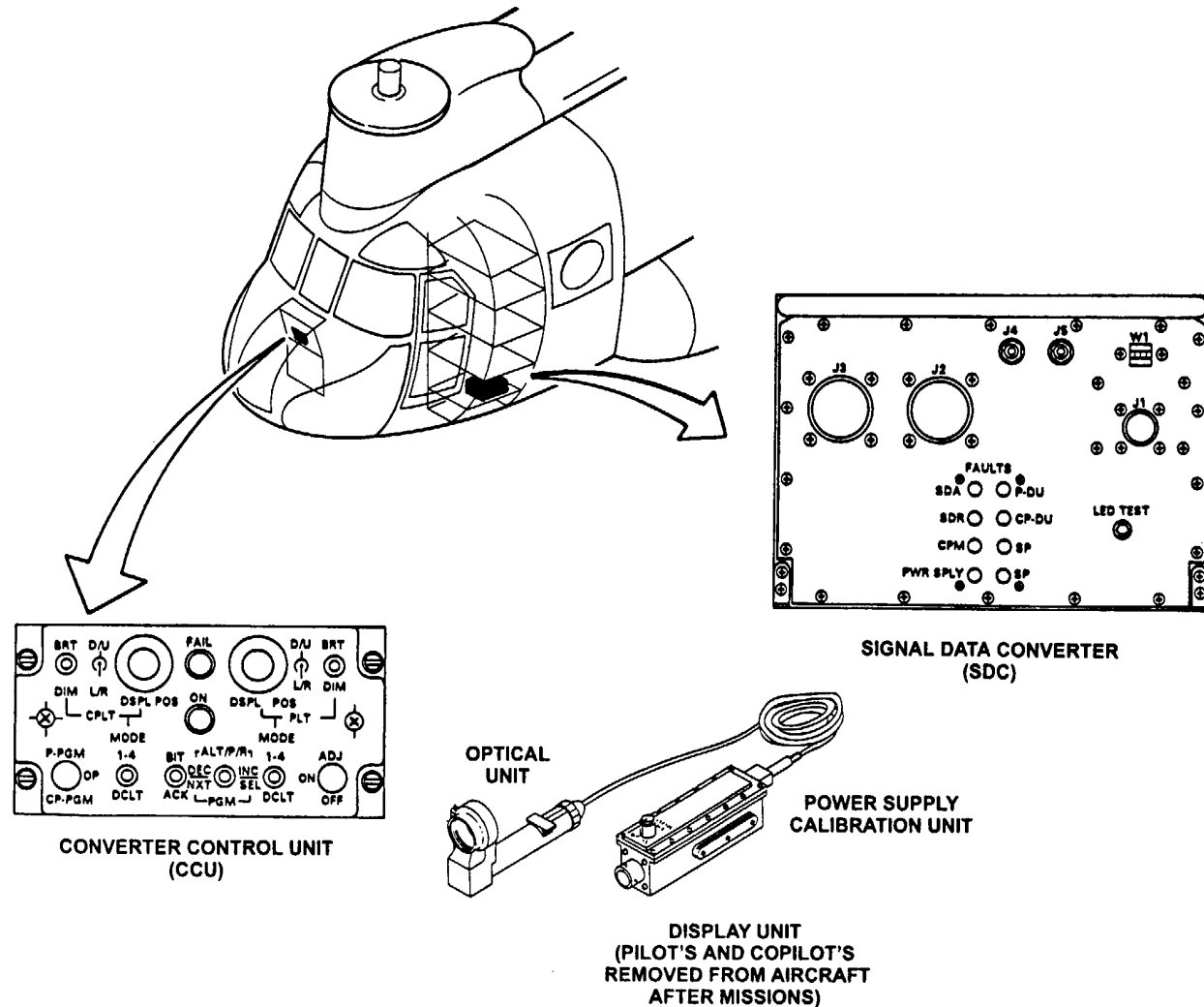

END OF TASK

FAULT ISOLATION PROCEDURE

Personnel Required:
Avionics Mechanic

INITIAL SETUP

Applicable Configurations:
All

References:
TM 55-1520-240-23
TM 11-5855-300-23&P

Tools:

Electronic Equipment Tool Kit,
NSN 5180-00-064-5178
Multimeter

Equipment Condition:
TM 55-1520-240-23:
Battery Connected
Electrical Power On

Materials:

None

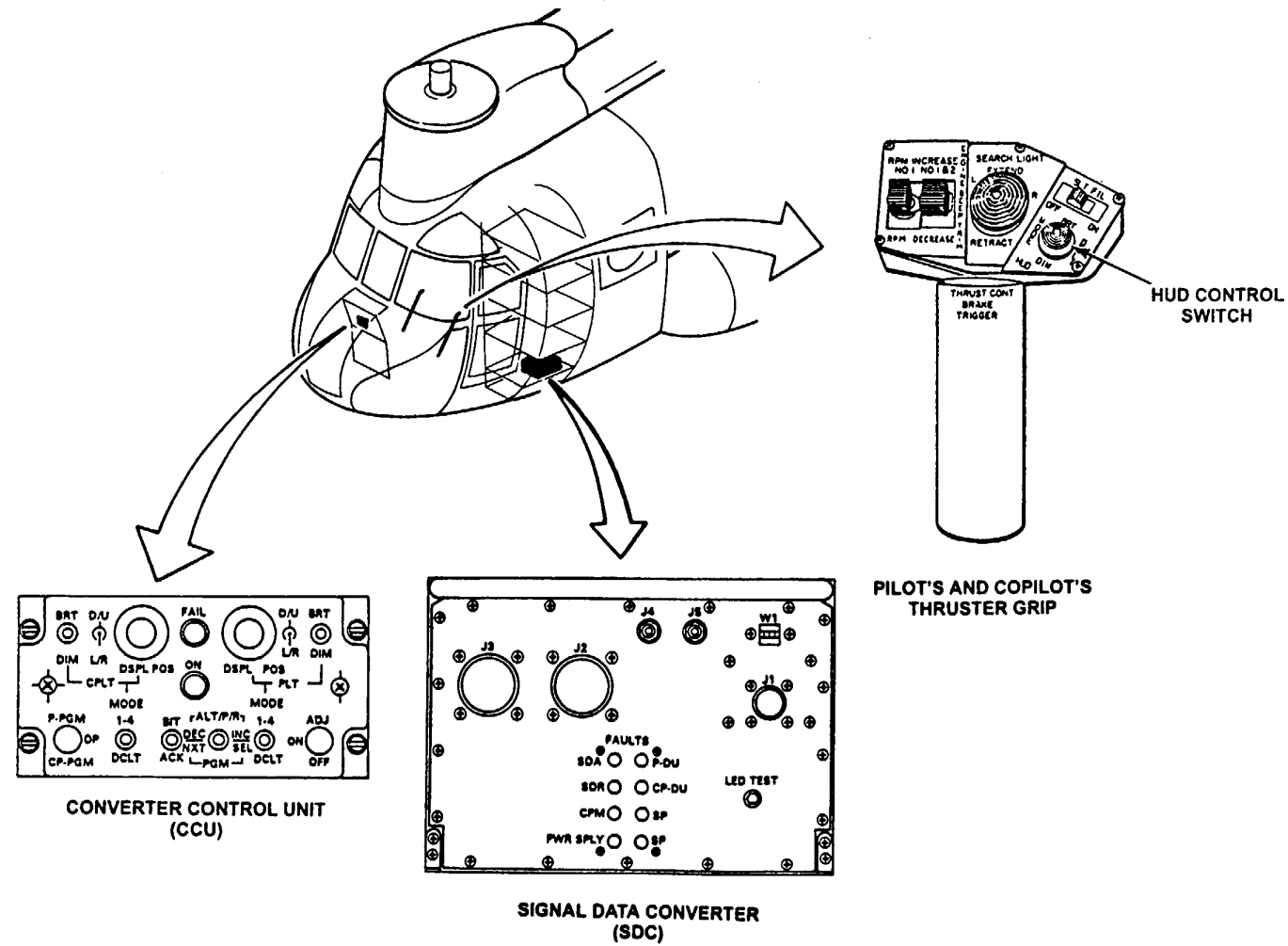
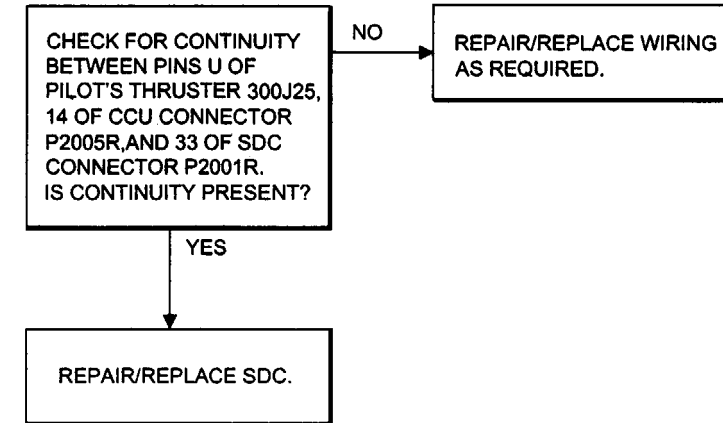

END OF TASK

16-4.26 CANNOT CYCLE THROUGH PILOT'S DECLUTTER AT CCU OR PILOT'S THRUSTER GRIP HUD CONTROL SWITCH

FAULT ISOLATION PROCEDURE

Personnel Required:
Avionics Mechanic

INITIAL SETUP

Applicable Configurations:

All

References:

TM 55-1520-240-23
TM 11-5855-300-23&P

Tools:

Electronic Equipment Tool Kit,
NSN 5180-00-064-5178
Multimeter

Equipment Condition:

TM 55-1520-240-23:
Battery Connected
Electrical Power On

Materials:

None

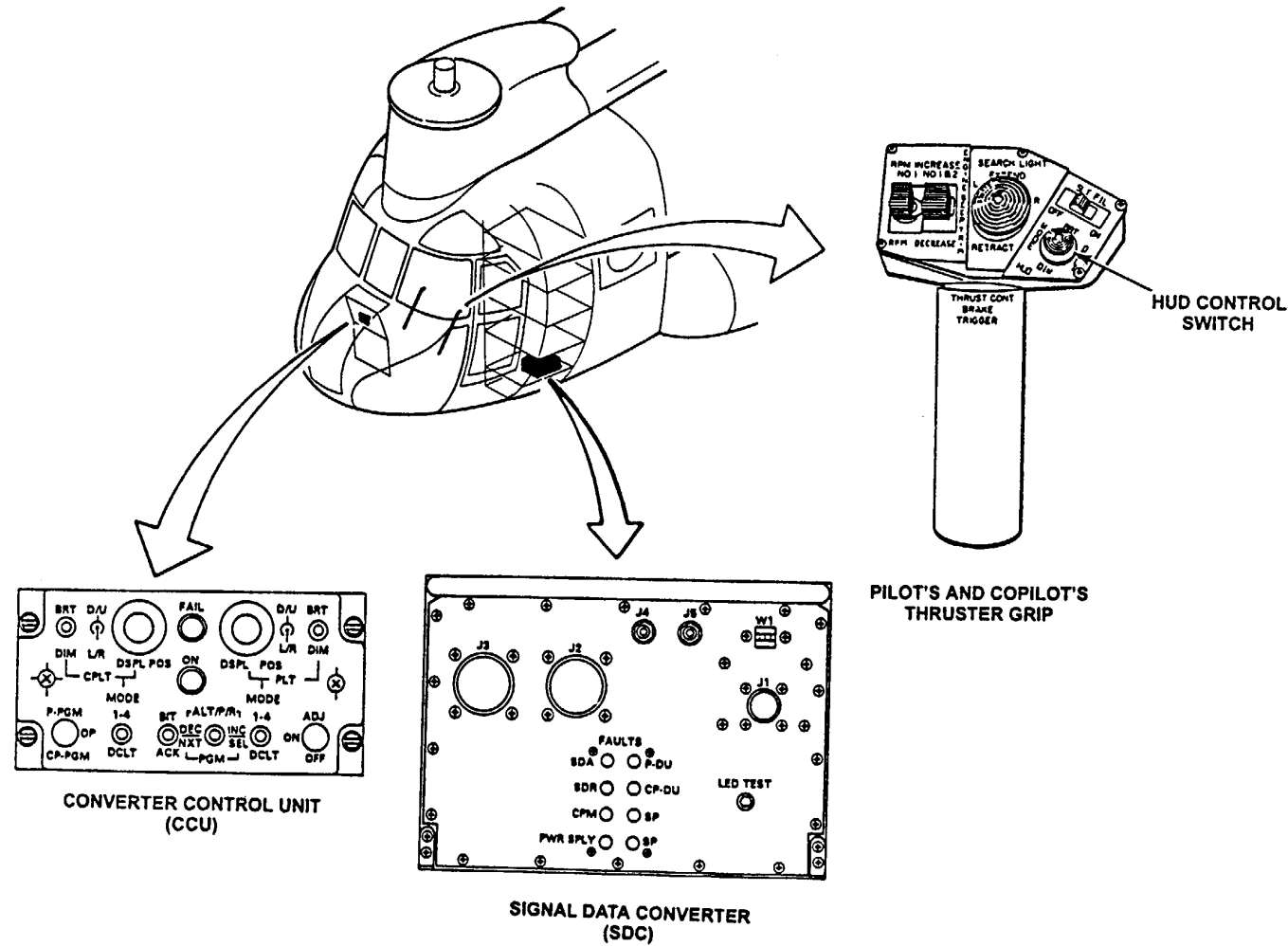
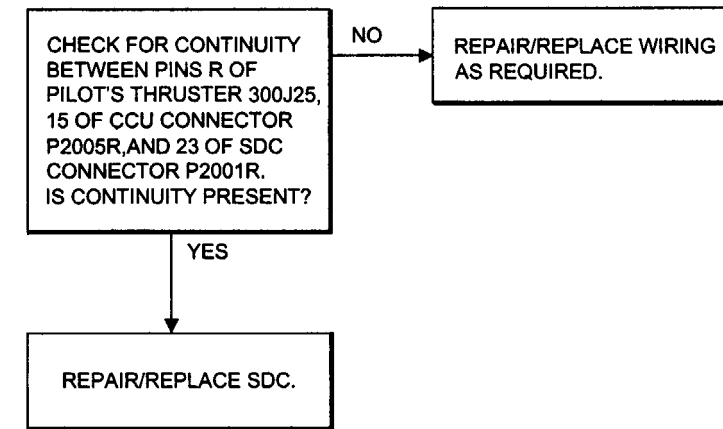

END OF TASK

FAULT ISOLATION PROCEDURE

Personnel Required:
Avionics Mechanic

INITIAL SETUP

Applicable Configurations:

All

References:

TM 55-1520-240-23
TM 11-5855-300-23&P

Tools:

Electronic Equipment Tool Kit,
NSN 5180-00-064-5178
Multimeter

Equipment Condition:

TM 55-1520-240-23:
Battery Connected
Electrical Power On

Materials:

None

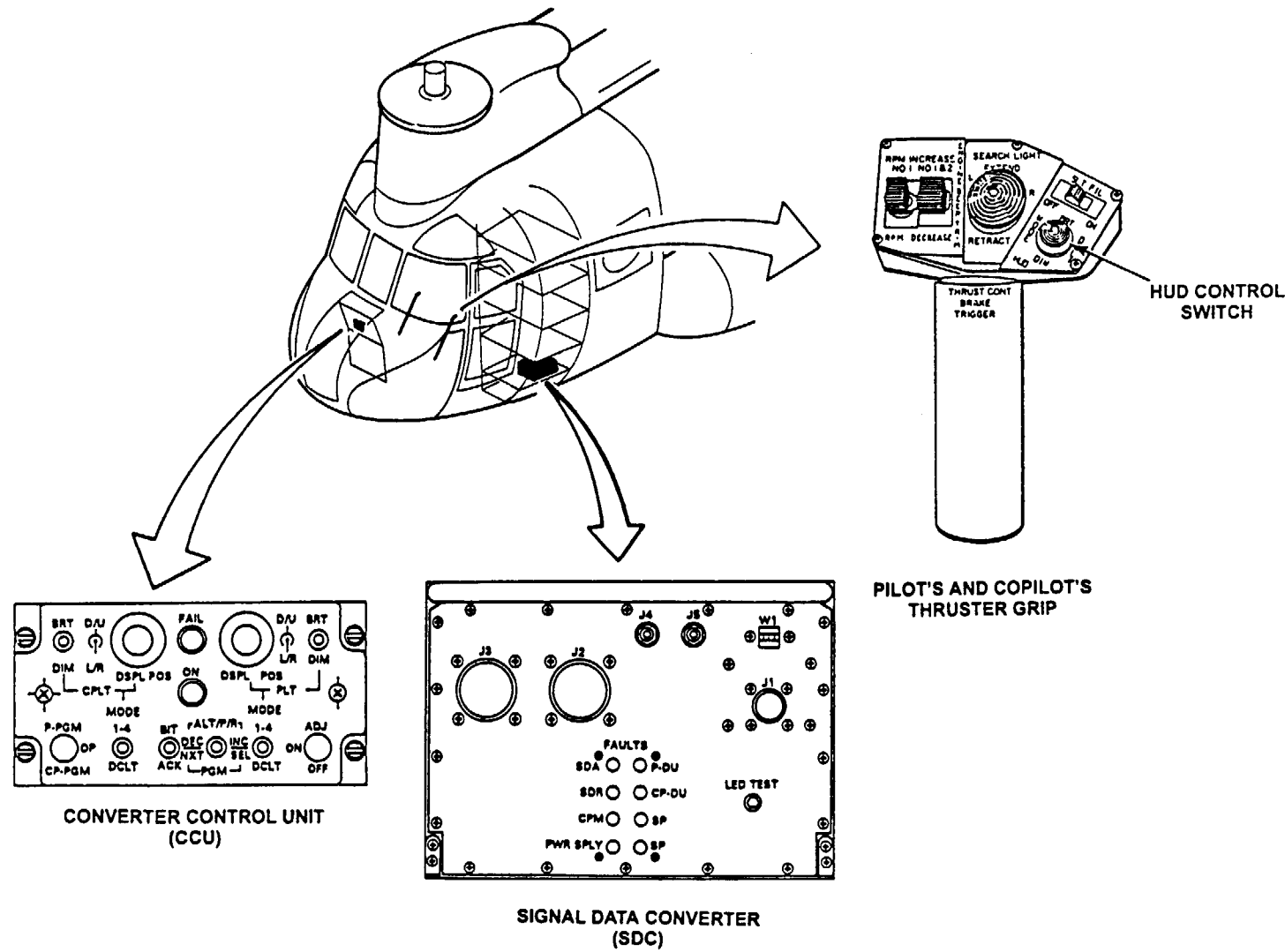
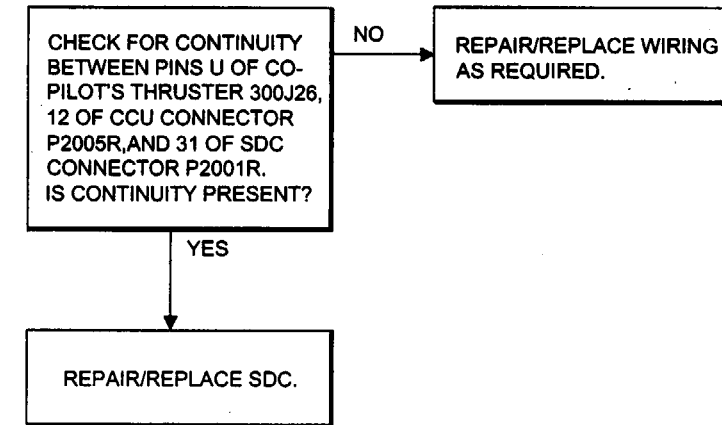

END OF TASK

16-4.28 CANNOT CYCLE THROUGH COPILOT'S DECLUTTER AT CCU OR COPILOT'S THRUSTER GRIP HUD CONTROL SWITCH

FAULT ISOLATION PROCEDURE

Personnel Required:
Avionics Mechanic

INITIAL SETUP

Applicable Configurations:
All

References:
TM 55-1520-240-23
TM 11-5855-300-23&P

Tools:

Electronic Equipment Tool Kit,
NSN 5180-00-064-5178
Multimeter

Equipment Condition:
TM 55-1520-240-23:
Battery Connected
Electrical Power On

Materials:

None

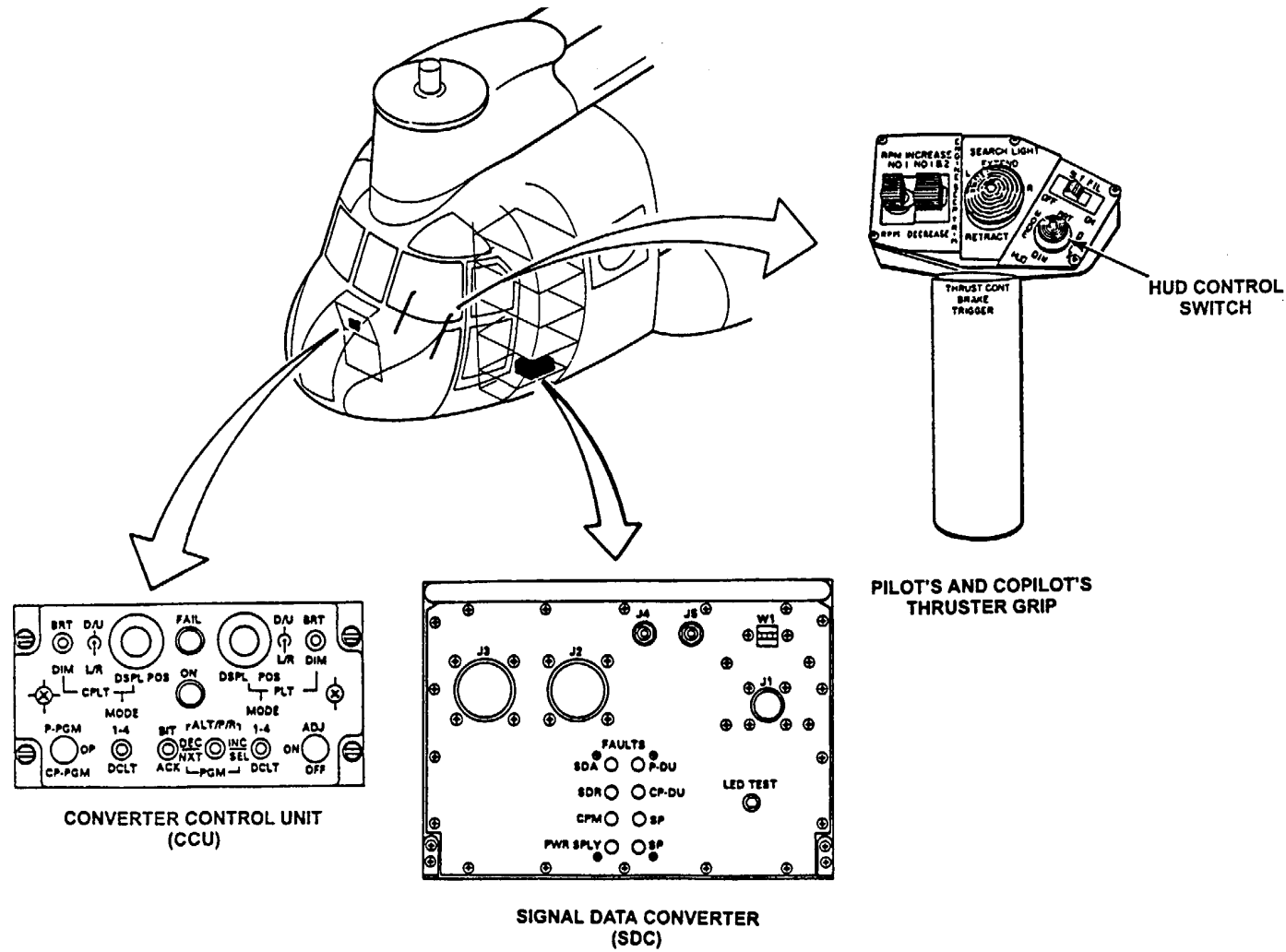
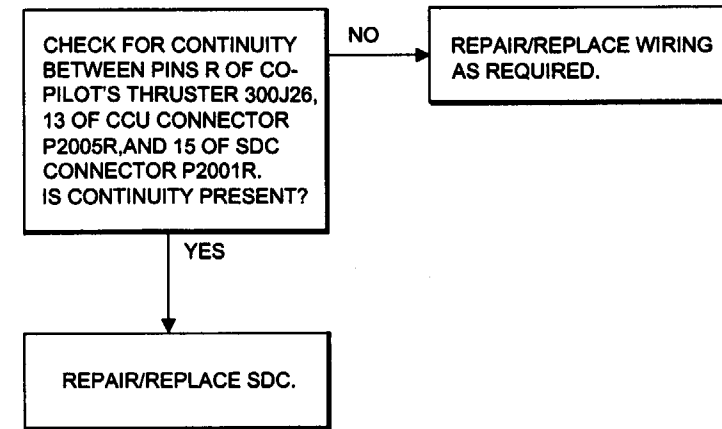

END OF TASK

FAULT ISOLATION PROCEDURE

INITIAL SETUP

Applicable Configurations:

All

Tools:

Electronic Equipment Tool Kit,
NSN 5180-00-064-5178
Multimeter

Materials:

None

Personnel Required:
Avionics Mechanic

References:
TM 55-1520-240-23
TM 11-5855-300-23&P

Equipment Condition:
TM 55-1520-240-23:
Battery Connected
Electrical Power On

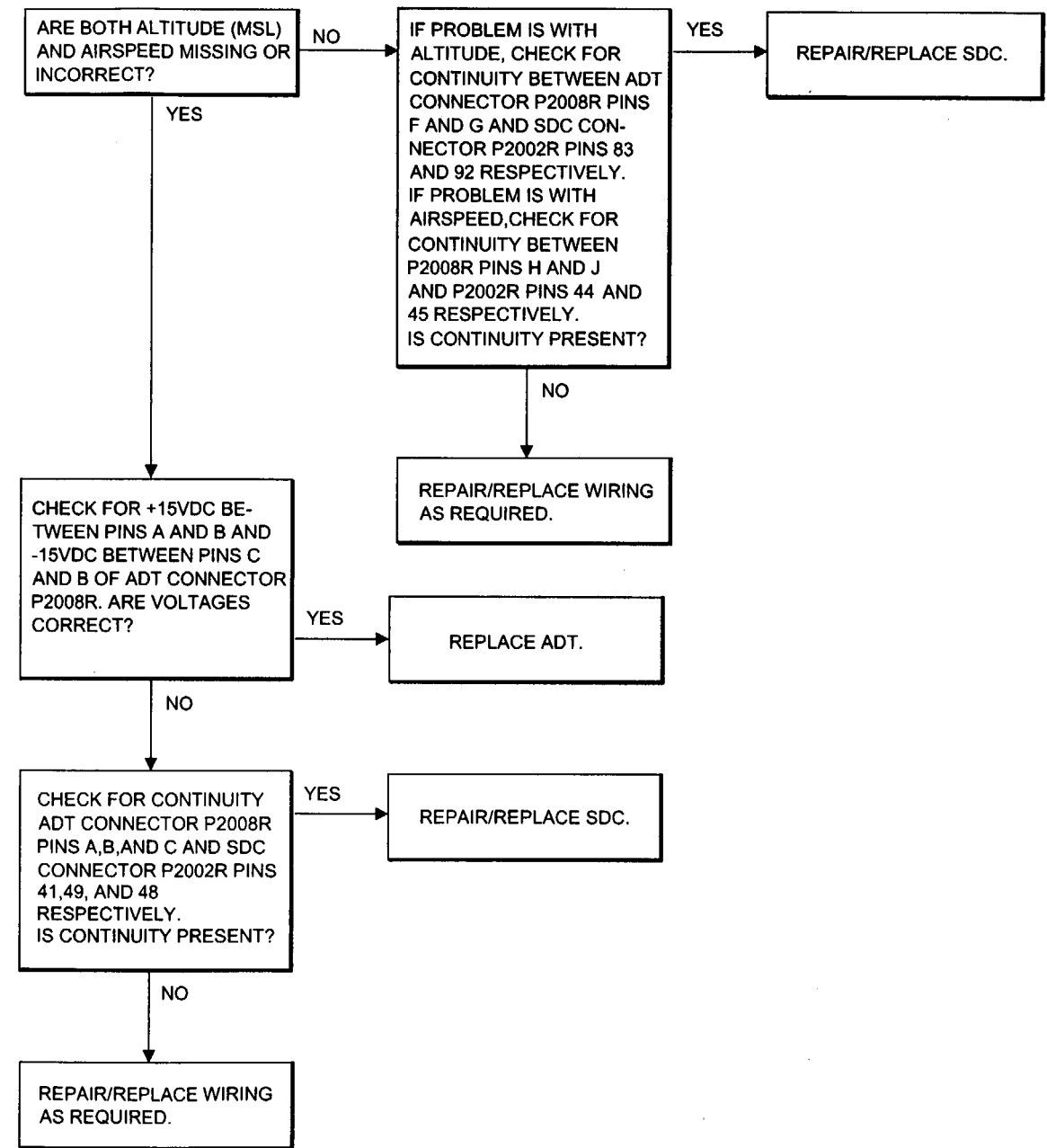
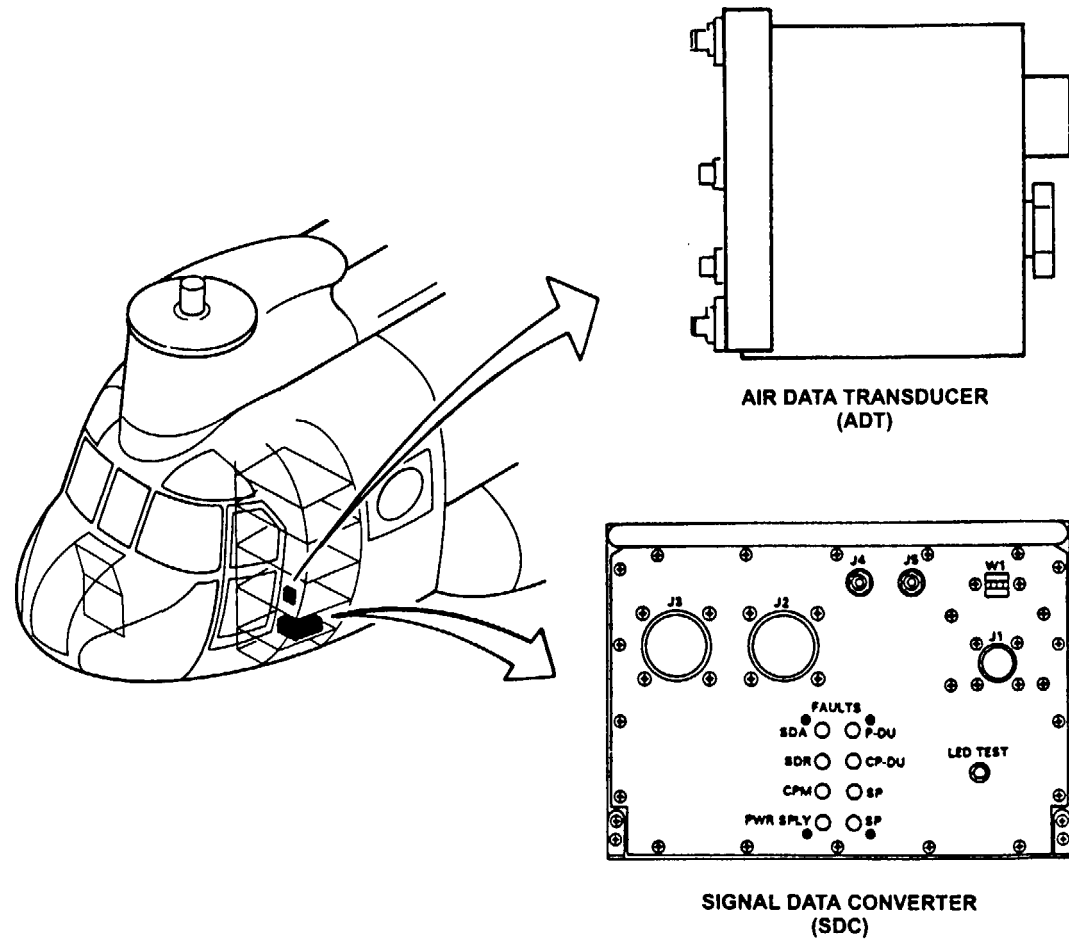

16-4.30 NO OR IMPROPER TRIM (SLIDE BALL) DISPLAYED

FAULT ISOLATION PROCEDURE

Personnel Required:
Avionics Mechanic

INITIAL SETUP

Applicable Configurations:
All

References:
TM 55-1520-240-23
TM 11-5855-300-23&P

Tools:

Electronic Equipment Tool Kit,
NSN 5180-00-064-5178
Multimeter

Equipment Condition:
TM 55-1520-240-23:
Battery Connected
Electrical Power On

Materials:

None

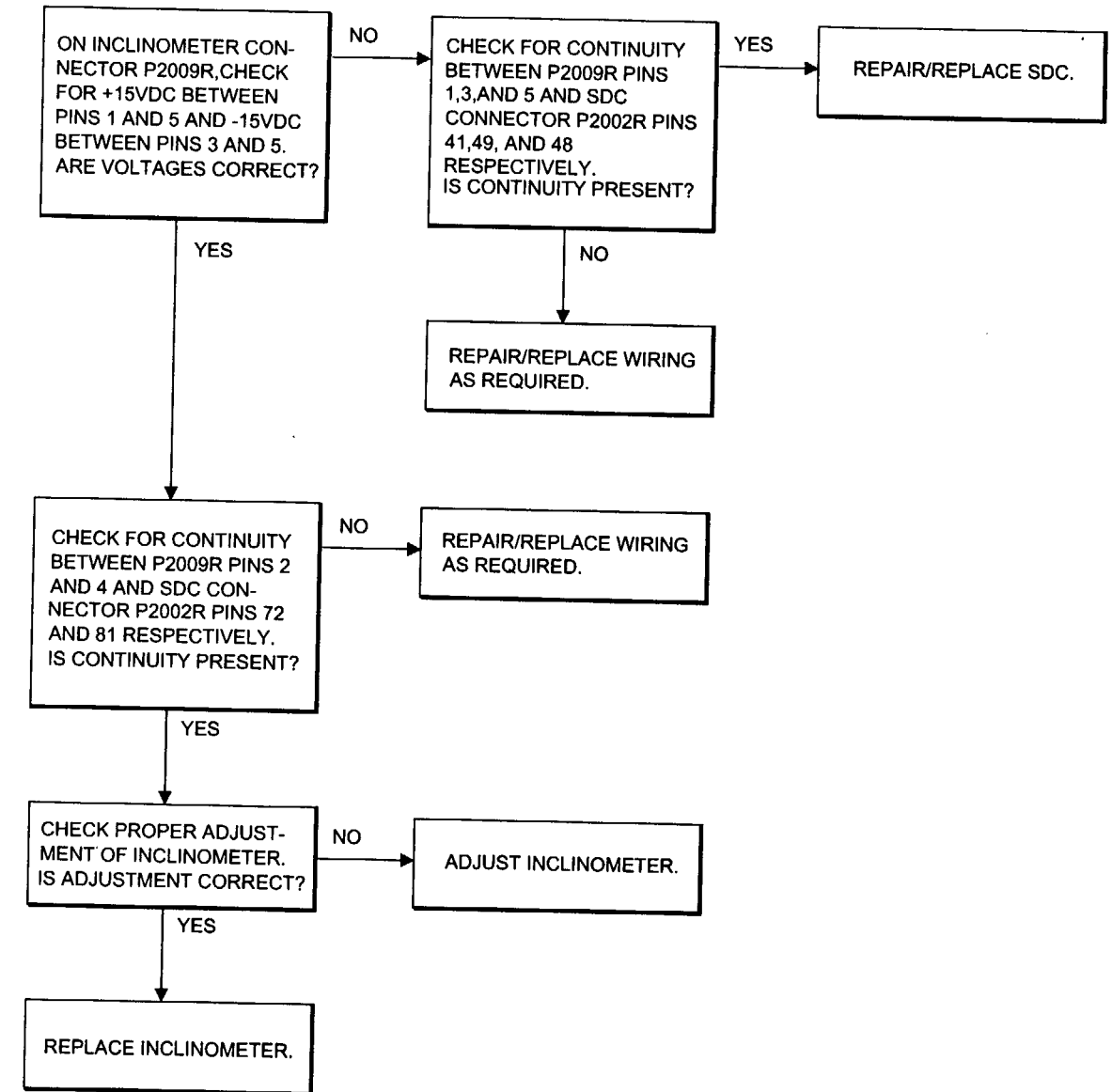
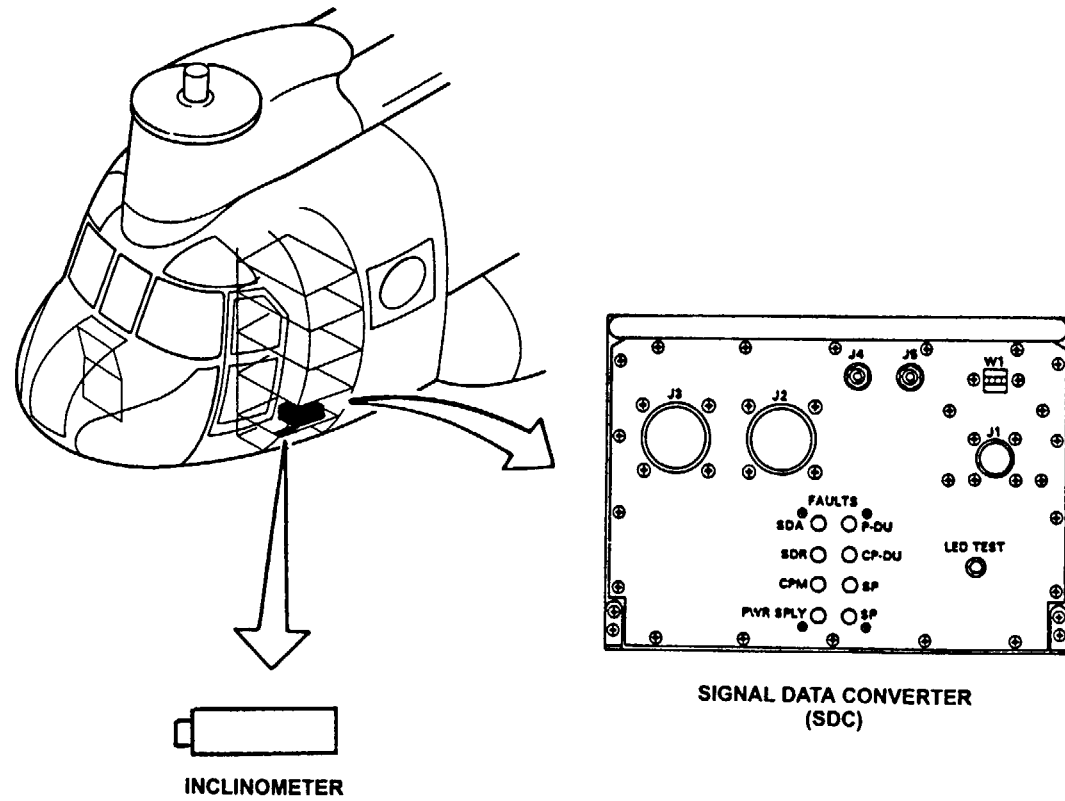

END OF TASK

16-5 AN/ALE-47 COUNTERMEASURES DISPENSER SYSTEM

|

NOTE:

AN/ALE-47 Countermeasures Dispenser System wiring diagrams are located on pages 16-183 through 16-187 (Sheets 2 of 6 through 6 of 6). Page 16-188 contains the wiring diagram for the Miscellaneous Control Panel which contains the AN/ALE-47 Digital Control Display Unit (DCDU), the LED Lighting Control and the Radar Altimeter Audio Control.

16-5.1 AN/ALE-47 COUNTERMEASURES DISPENSER SYSTEM WIRING DIAGRAMS (Continued)

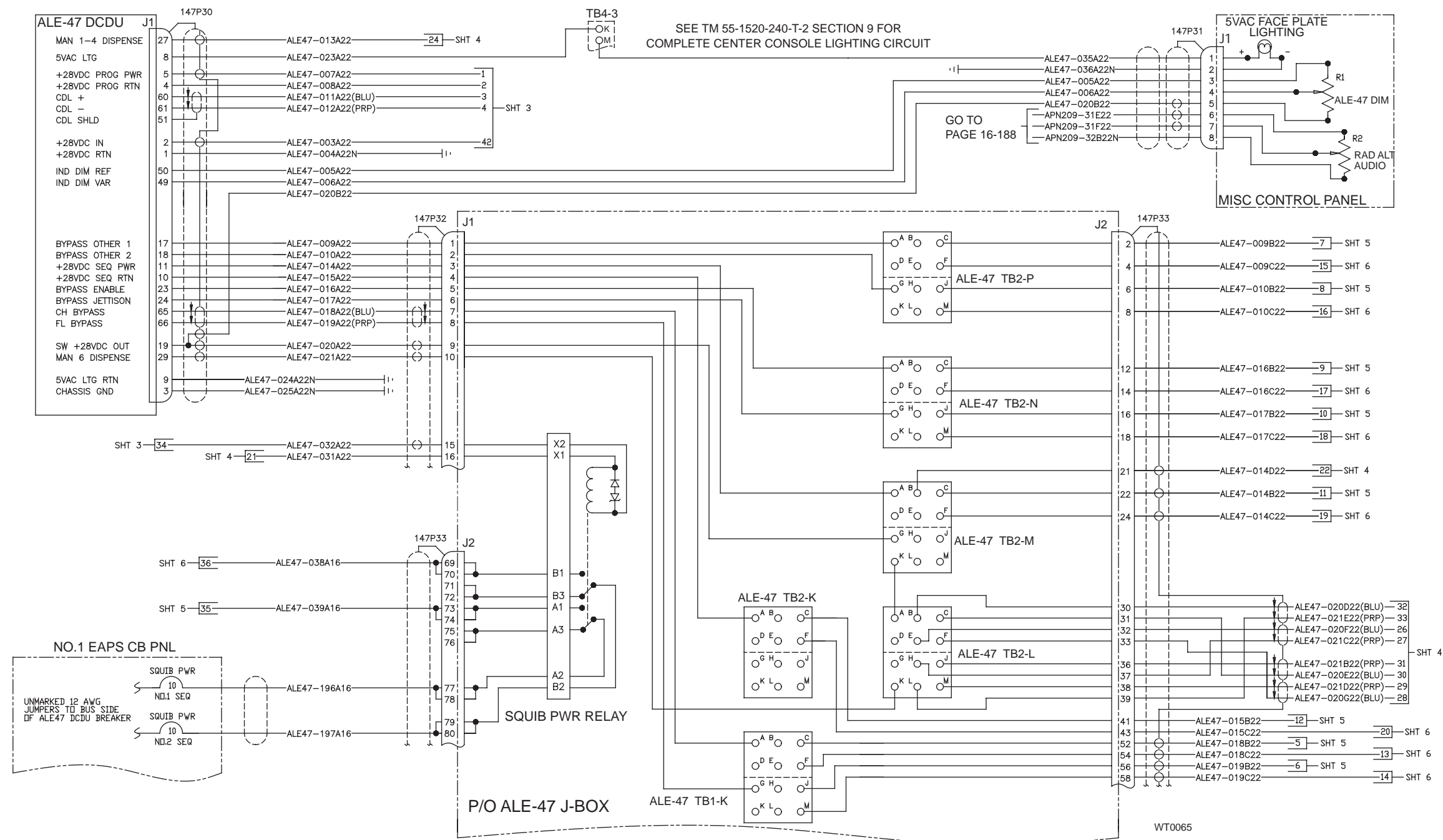

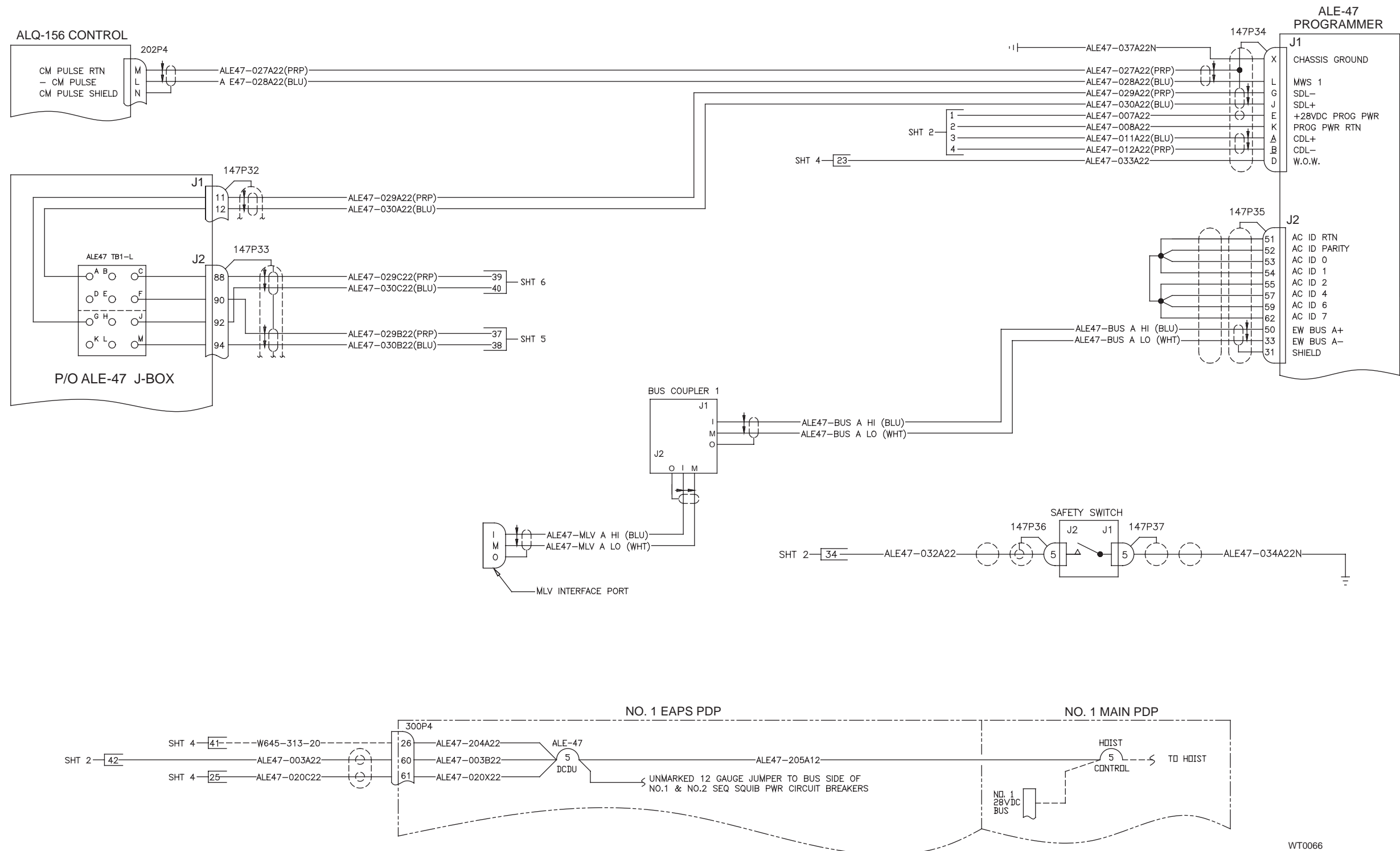

WT0066

16-5.1 AN/ALE-47 COUNTERMEASURES DISPENSER SYSTEM WIRING DIAGRAMS (Continued)

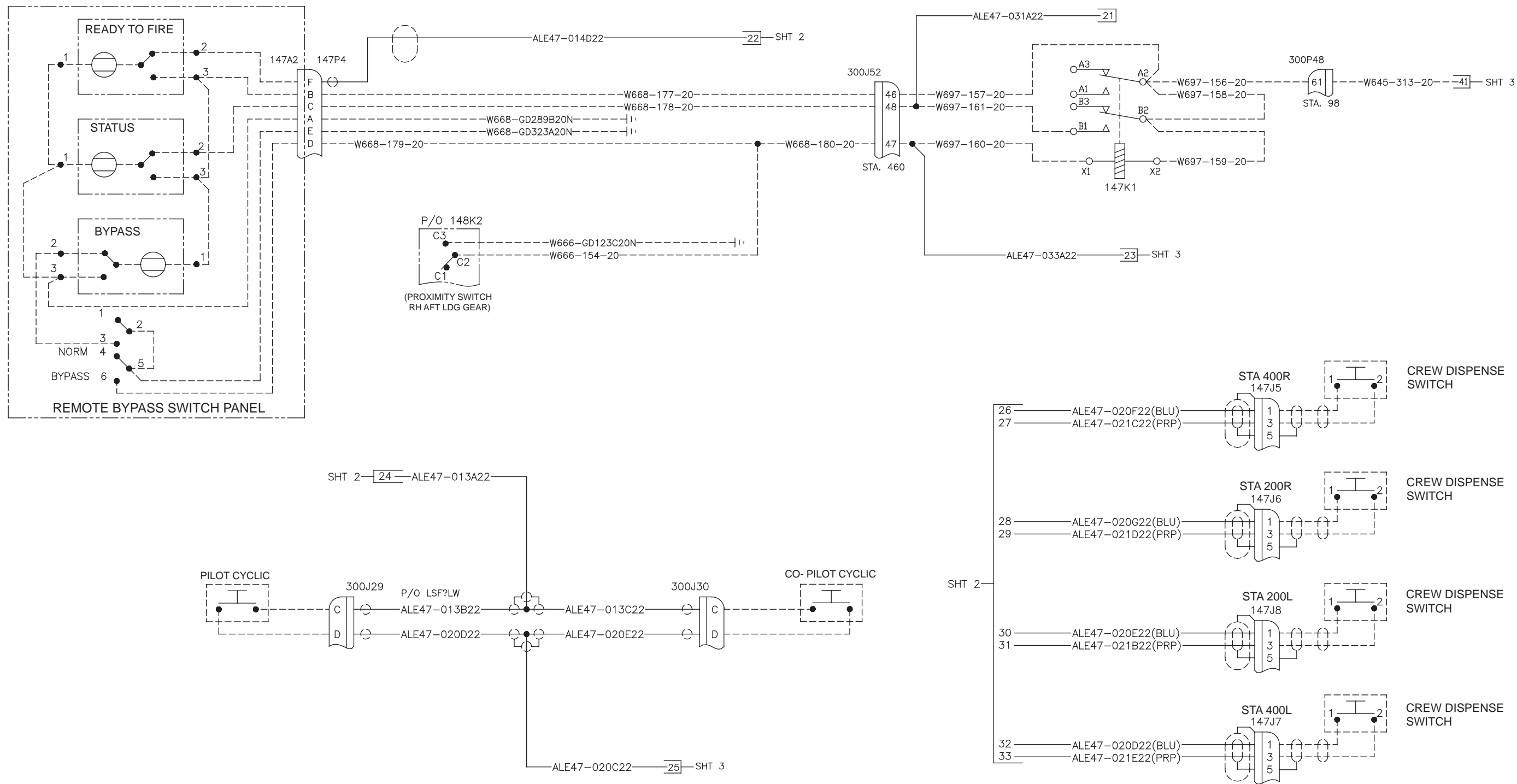

WT0067

16-5.1 AN/ALE-47 COUNTERMEASURES DISPENSER SYSTEM WIRING DIAGRAMS (Continued)

NO. 2 SEQUENCER (RH)

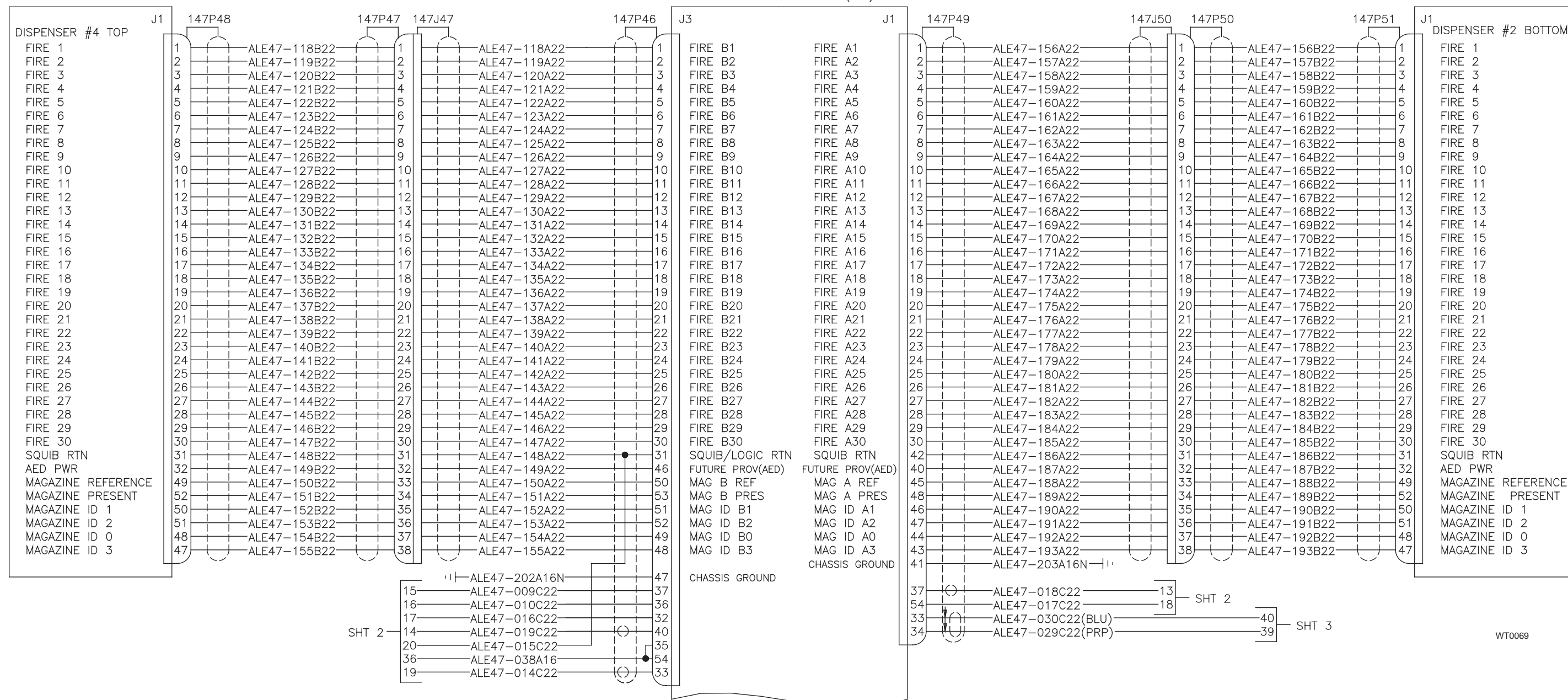

WT0069

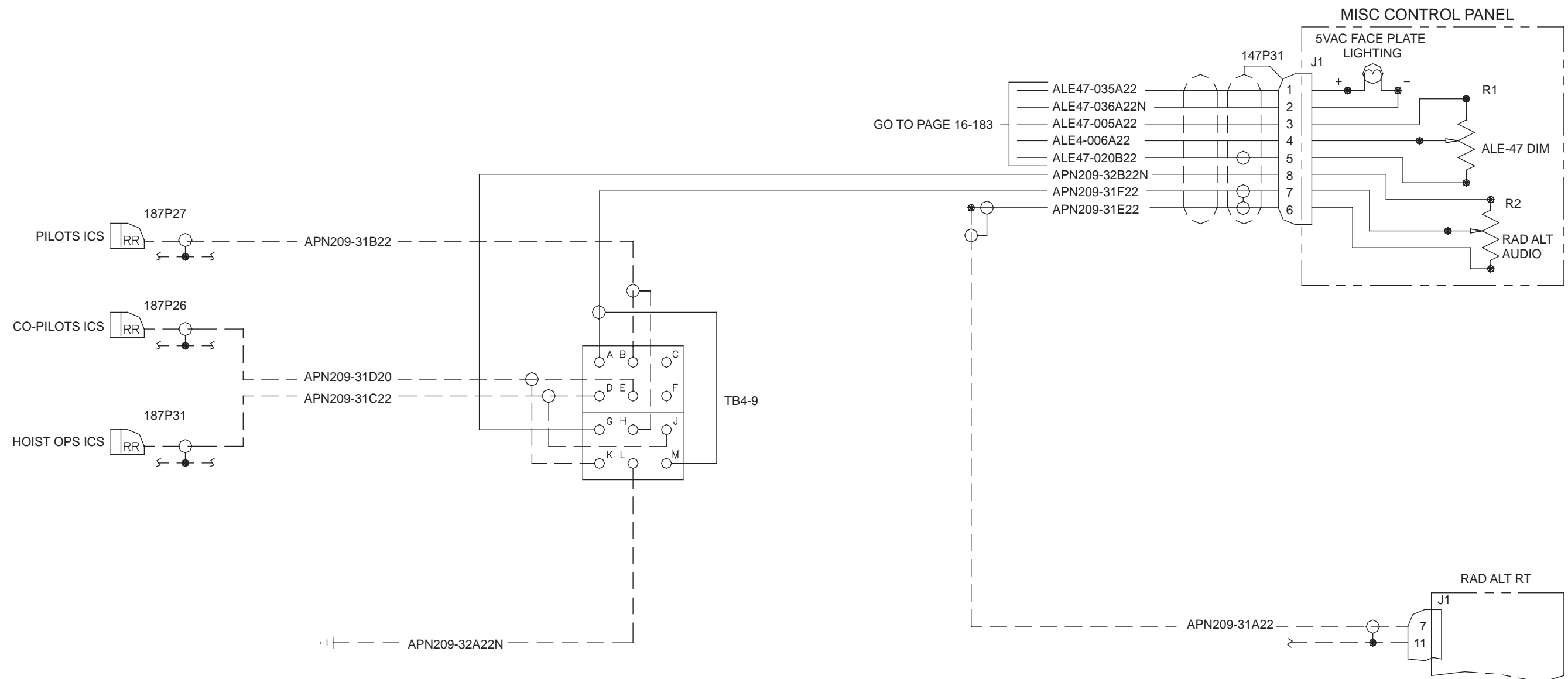

WT0071

END OF TASK

16-5.2 AN/ALE-47 COUNTERMEASURES DISPENSER SYSTEM VISUAL CHECK

INITIAL SETUP

Applicable Configurations:
All

Tools:
Electronic Equipment Tool Kit,
NSN 5180-00-064-5178

Materials:
Cloth (E120)

Personnel Required:
Avionics Mechanic

References:
TM 55-1520-240-10
TM 55-1520-240-23
TM 1-1500-343-23

Equipment Condition:

TM 55-1520-240-10
AN/ALE-47 Safety Switch pin installed
TM 55-1520-240-23
Battery connected
Electrical power Off
Hydraulic power Off

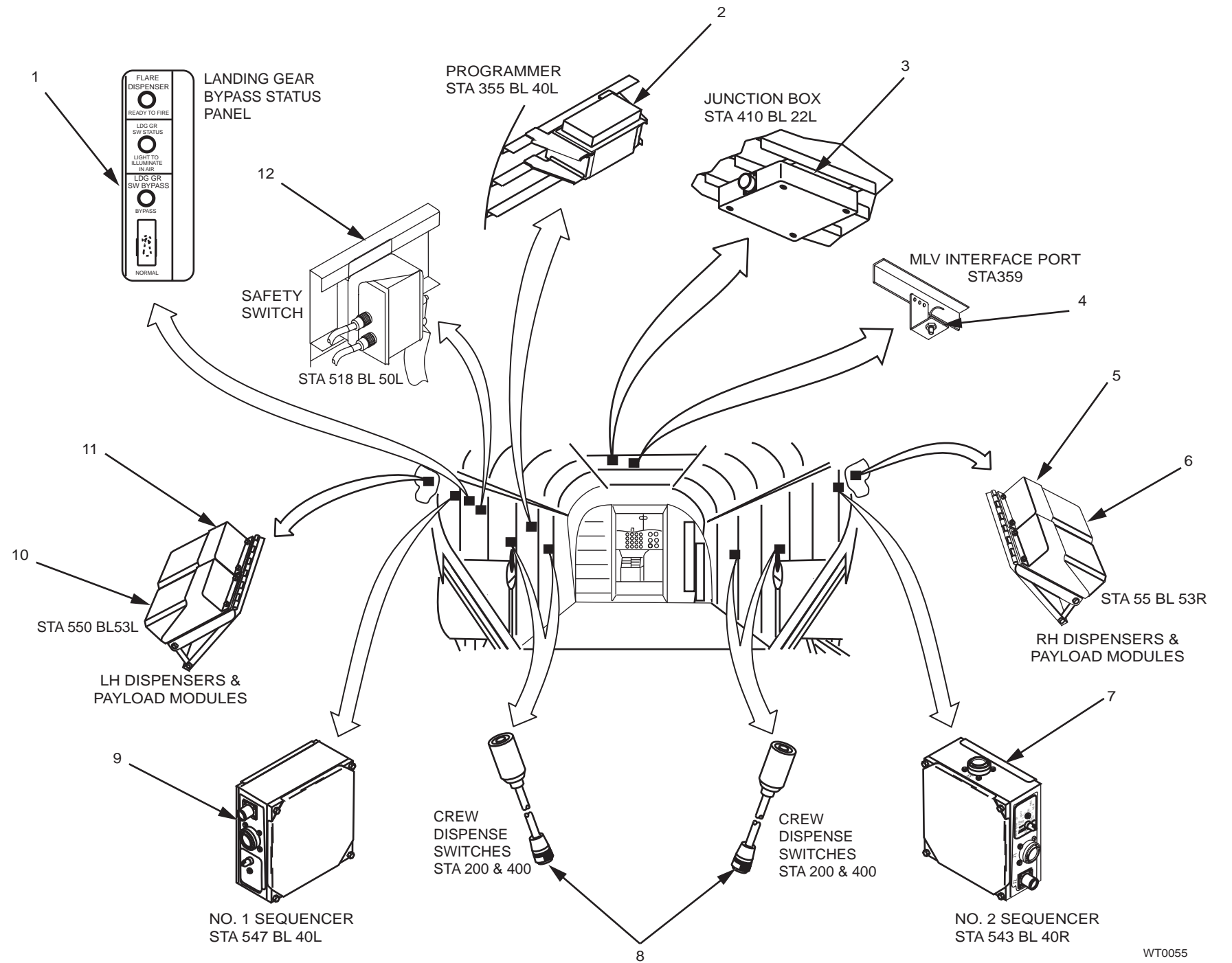
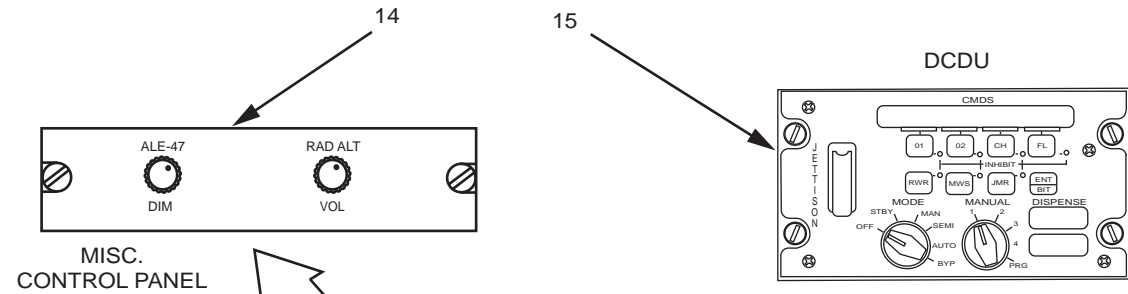

WT0055

GO TO NEXT PAGE

16-5.2 AN/ALE-47 COUNTERMEASURES DISPENSER SYSTEM VISUAL CHECK (Continued)

16-5.2

TASK	RESULT
1. Check FLARE DISPENSE switches (13) on pilot's and copilot's cyclic stick grips.	If switch is damaged, replace cyclic stick grip.
2. Check DCDU (15) switches, indicators, displays, and lights.	If any switch, indicator, display, or light is damaged, replace DCDU (15).
3. Check miscellaneous control panel (14).	If miscellaneous control panel (14) is loose or damaged, tighten or replace as required.
4. Check programmer (2), electrical connectors, and plugs.	If programmer (2) is loose or damaged, tighten or replace as required. If connectors or plugs are loose or damaged, tighten or replace as required.
5. Check No. 1 (9) and No. 2 (7) sequencers, switches, electrical connectors, and plugs.	If sequencer (7 or 9) is loose or damaged, tighten or replace as required. If switch is damaged, replace sequencer. If connector or plug is damaged, tighten or replace as required.
6. Check landing gear bypass status panel (1), lights, switches, electrical connectors, and plugs.	If any light or switch on panel (1) is damaged, replace as required. If connector to panel is loose or damaged, tighten or replace as required. If wiring to connector is damaged, repair or replace as required.
7. Check safety switch (12), safety pin, electrical connectors, and plugs.	If safety switch (12) is loose or damaged, tighten or replace as required. If safety pin is damaged, replace it. If safety pin streamer is missing or frayed, replace it. If connector or plugs are loose or damaged, tighten or replace as required.
8. Check junction box (3), connectors, and plugs.	If junction box (3) is loose or damaged, tighten or replace as required. If connector or plug is loose or damaged, tighten or replace as required.
9. Check MLV interface port (4), electrical connector.	If MLV interface port (4) is loose or damaged, tighten or replace as required. If connector is loose or damaged, tighten or replace as required.
10. Check crew dispense switches (8), electrical connectors, and plugs.	If crew dispense switch (8) is loose or damaged, tighten or replace as required. If connector or plug is loose or damaged, tighten or replace as required.
11. Check payload modules (6 and 10) and dispenser assemblies (5 and 11) wiring, electrical connectors, and electrical plugs.	If payload modules (6 or 10) or dispenser assemblies (5 or 11) are loose or damaged, tighten or replace as required. If module or dispenser wiring, connector, or plugs are loose or damaged, tighten or replace as required.

TASK	RESULT
WARNING	
	Dirty, loose or damaged electrical contact between the payload module EMI gasket/breech plate and dispenser assembly contacts and ground springs can cause misfires of the counter-measures munitions.
12. Check payload modules (6 and 10) EMI gasket/breech plate and dispenser assembly (5 and 11) contacts and ground springs.	If payload modules (6 and 10) EMI gasket/breech plate or dispenser assembly (5 and 11) contacts and ground springs are dirty, loose or damaged, clean, tighten or replace as required.
FOLLOW-ON MAINTENANCE:	
None	

INITIAL SETUP

Applicable Configurations:

All

References:

TM 55-1520-240-10
TM 55-1520-240-23

Tools:

Electronic Equipment Tool Kit
NSN 5180-00-064-5178
Countermeasures Dispenser Test Set
P/N 341000-7001

General Safety Instructions:

WARNING

Do not perform operational check with payload modules (magazines) installed. During checkout procedures, voltage is applied to dispenser assemblies which may result in inadvertent dispensing of expendables causing death or injury to personnel or damage to equipment.

Materials:

None

Personnel Required:

Avionics Mechanic

Equipment Condition:

TM 55-1520-240-10
AN/ALE-47 safety switch safety pin installed
AN/ALQ-156 MWS installed
TM 55-1520-240-23
Battery connected
Payload modules removed (TM 55-1520-240-23-10)
Visual check of CMDS performed (Task 16-5.2).
Electrical power Off
Hydraulic power Off

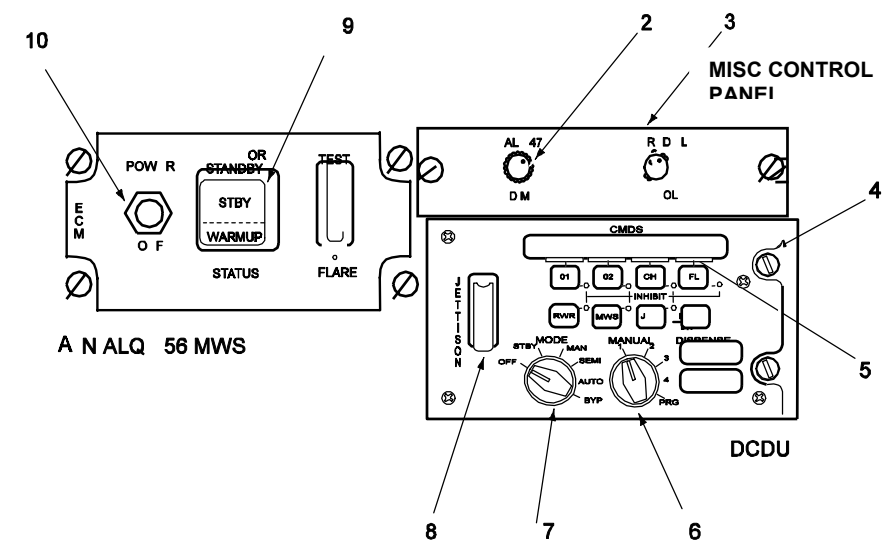
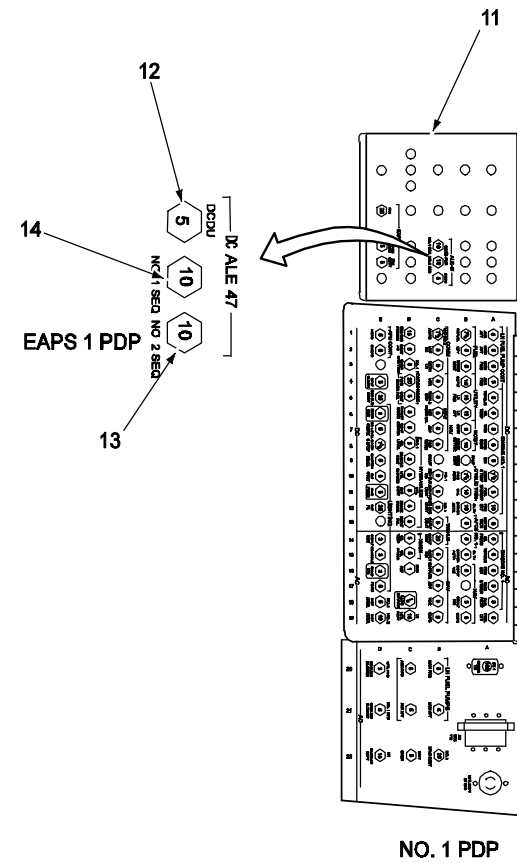
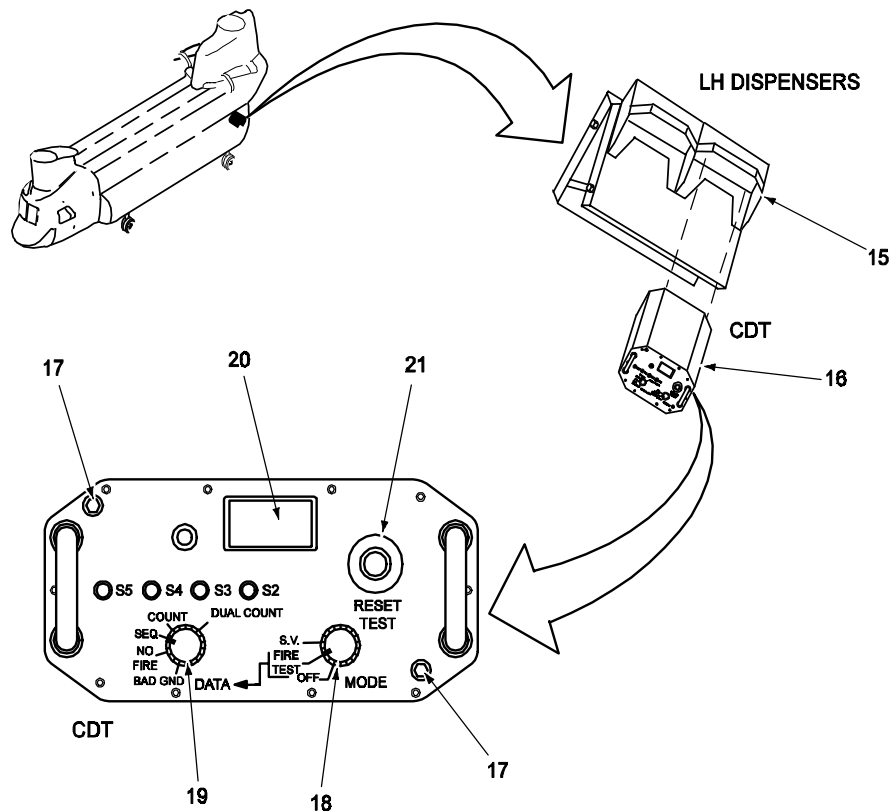
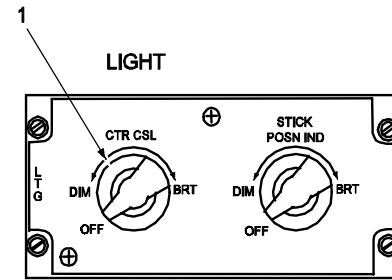

GO TO NEXT PAGE

16-5.3 AN/ALE-47 COUNTERMEASURES DISPENSER SYSTEM OPERATIONAL CHECK (Continued)

16-5.3

TASK	RESULT
NOTE	
Do not install CDTs into Countermeasures Dispenser System (CMDS) dispenser assemblies before performing CDT BIT check.	
1. Set CDT MODE switch (18) to FIRE TEST.	BIT begins automatically. The following displays appear on the CDT: All CDT indicators illuminate briefly. BIT is displayed on upper display field. "S-" and software version number is displayed If no fault is detected PASS message is displayed. If fault is detected FAIL message is displayed, set MODE switch to OFF and replace CDT.
2. Set CDT DATA switch (19) to COUNT or DUAL COUNT (chaff use).	
3. Check CDT display (20) for battery message.	If LOW BAT is displayed, refer to TM 341003 (Operation and Maintenance Technical Manual) accompanying CDTs.
4. Set CDT MODE switch (18) to OFF.	
NOTE	
If erroneous expendable counts are displayed, fastening knobs may require additional tightening.	
5. Install CDTs (16) into flare dispenser assemblies (15) being tested; secure CDTs (16) by tightening two fastening knobs (17).	
6. Apply electrical power to aircraft.	
NOTE	
Proceed with AN/ALE-47 CMDS operational checkout while AN/ALQ-156 MWS is warming up.	
7. Set AN/ALQ-156 POWER switch (10) to ON; press AN/ALQ-156 PUSH FOR STANDBY switch (9) to initiate standby mode.	After 10 minutes, STBY light on AN/ALQ-156 illuminates.
8. Set CDT MODE switch (18) to S.V. (stray voltage).	

TASK	RESULT
9. Press CDT RESET TEST switch (21).	DC followed by AC is displayed on CDT display (20) for 4 seconds. If stray voltage is not detected, PASS is displayed. If FAIL message is displayed, failed pin numbers will then be displayed. Record failed pin numbers. This is an indication that stray voltage was detected on the dispenser breechplate terminals. This condition must be corrected before proceeding with the operational check. Power down the AN/ALQ-156 MWS and remove power from aircraft. Starting at the dispenser pins, use multimeter to locate the source of stray voltage. If CMDS is not the source of the stray voltage, the aircraft wiring must be checked to locate and repair the stray voltage condition.
10. Set CDT MODE switch (18) to OFF.	
WARNING	
Do not perform operational checkout of CMDS with payload modules installed in dispenser assemblies. System could inadvertently dispense flares resulting in damage to aircraft or injury or death to personnel.	
11. Ensure DCALE47DCDU (12), NO. 1 SEQ (14), and NO. 2 SEQ (13) circuit breakers on EAPS 1 PDP (11) are closed (in).	If DCALE47 DCDU circuit breaker is open, close it. If it does not stay closed, go to Task 16-5.4.
12. Adjust DCDU (4) and Misc. Control panel (3) edge lighting from dim to bright and set as desired using LTG CTR CSL switch (1) on cockpit overhead instrument panel.	DCDU and misc. control panel edge brightness goes from dim to bright as control is rotated.
13. Set the following switches on DCDU (4): JETTISON switch (8) – OFF (switch guard closed) MANUAL switch (6) – 1	
14. Set CDT MODE switch (18) to FIRE TEST.	
15. Set CDT DATA switch (19) to COUNT.	a. All CDT indicators illuminate briefly. b. BIT is displayed on upper display field. c. "S-" and version number is displayed on CDT. d. BIT begins automatically. e. BIT FAIL message is displayed, press RESET TEST button (21) on CDT; FIRE and 00 messages are displayed.

GO TO NEXT PAGE

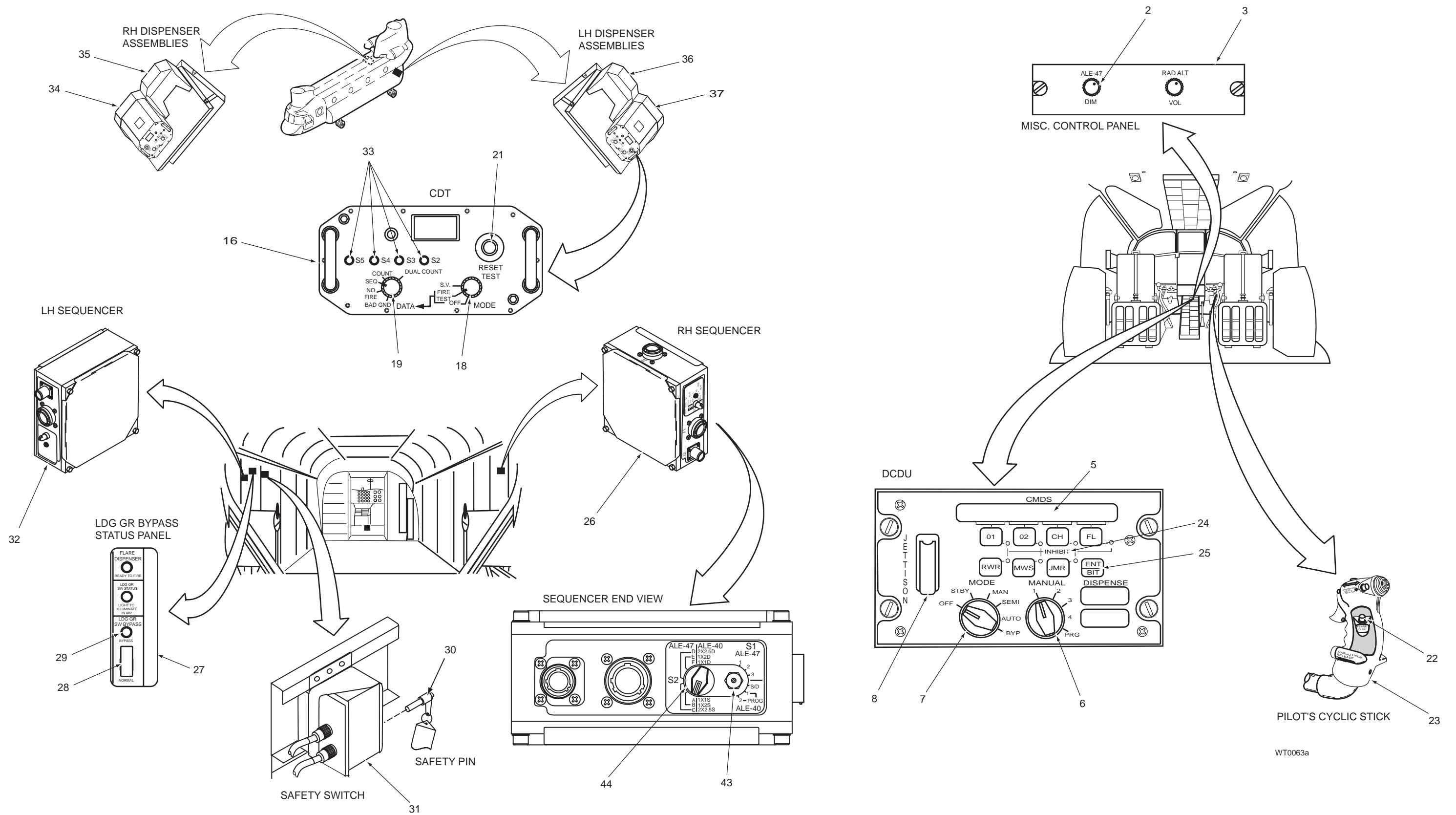

WT0063a

GO TO NEXT PAGE

16-5.3 AN/ALE-47 COUNTERMEASURES DISPENSER SYSTEM OPERATIONAL CHECK (Continued)

16-5.3

TASK	RESULT	TASK	RESULT																																		
<p>NOTE</p> <p>If no expendable counts or an erroneous counts Are displayed, on the CDTs the payload MAG ID Encoding pin switches S2, S3, S4 or S5 may be Set incorrectly.</p>		21. Press and release DCDU ENT/BIT switch to view alphanumeric and symbology display test.	Verify DCDU display scrolls through letters, numbers And symbols. When display finishes scrolling, TESTING SWITCHES will be displayed.																																		
16. Press and turn payload coding pins (33) on CDTs (16) to lock-in, set payload MAG ID codes as follows. All other coding pins should be unlocked-out:		22. Actuate each DCDU switch and verify DCDU display registers the engagement and disengagement of the associated switch and discrete interfaces.	<p>If DCDU letters, numbers and symbols are not displayed Replace DCDU.</p> <p>If DCDU does not display TESTING SWITCHES, replace DCDU.</p> <p>a. FL switch: FLARE ON and FLARE INHIBITED b. CH switch: CHAFF ON and CHAFF INHIBITED c. 01 switch: OTHER1 ON and OTHER1 INHIBITED d. 02 switch: OTHER2 ON and OTHER2 INHIBITED e. RWR switch: RWR ON and RWR INHIBITED f. JMR switch: JAMMER ON and JAMMER INHIBITED g. MWS switch: MWS ON and MWS INHIBITED h. JETTISON switch: JETTISON ON and JETTISON INHIBITED i. MODE switch: MODE ON and MODE INHIBITED j. MANUAL switch: MANUAL PROGRAM1, MANUAL PROGRAM2, MANUAL PROGRAM3, MANUAL PROGRAM4</p> <p>If any switch fails during actuation, replace DCDU.</p>																																		
<table border="1"> <thead> <tr> <th rowspan="2">CDT POSITION</th> <th colspan="4">CODING PIN POSITIONS</th> <th rowspan="2">MAG ID</th> </tr> <tr> <th>S2</th> <th>S3</th> <th>S4</th> <th>S5</th> </tr> </thead> <tbody> <tr> <td>DISP #1 (37)</td> <td>X</td> <td>O</td> <td>O</td> <td>O</td> <td>1</td> </tr> <tr> <td>DISP #2 (34)</td> <td>O</td> <td>O</td> <td>O</td> <td>X</td> <td>8</td> </tr> <tr> <td>DISP #3 (36)</td> <td>X</td> <td>O</td> <td>O</td> <td>O</td> <td>1</td> </tr> <tr> <td>DISP #4 (35)</td> <td>O</td> <td>O</td> <td>O</td> <td>X</td> <td>8</td> </tr> </tbody> </table> <p>“X” = Locked (Pressed in) Coding Pin “O” = Unlocked (Out) Coding Pin</p>	CDT POSITION	CODING PIN POSITIONS				MAG ID	S2	S3	S4	S5	DISP #1 (37)	X	O	O	O	1	DISP #2 (34)	O	O	O	X	8	DISP #3 (36)	X	O	O	O	1	DISP #4 (35)	O	O	O	X	8		23. On Pilot’s Cyclic Grip, press and release the dispense switch. Repeat for Copilots dispense Switch.	<p>Verify DCDU displays MANUAL DISPENSE, and then displays MANUAL DISP OFF.</p> <p>If DCDU does not display results, go to Task 16-5.10 For pilot and 16-5.9 for copilot.</p>
CDT POSITION		CODING PIN POSITIONS					MAG ID																														
	S2	S3	S4	S5																																	
DISP #1 (37)	X	O	O	O	1																																
DISP #2 (34)	O	O	O	X	8																																
DISP #3 (36)	X	O	O	O	1																																
DISP #4 (35)	O	O	O	X	8																																
17. Set DCDU MODE switch (7) to STBY.	<p>DCDU performs initiated BIT (IBIT). A momentary illumination of the OFP (operational flight program) ####, MDF (mission data file) #### version; then payload inventory ## ## __ ## is displayed.</p> <p>If erroneous expendable counts are displayed, fastening knobs may require additional tightening.</p> <p>Confirm displayed OFP and MDF match the version numbers of the OFP and MDF documents for your unit.</p> <p>If NO GO is displayed on the DCDU go to step 20. If DISPENSE READY is displayed go to step 23.</p>	24. In cabin, press and release the crew dispense switch. Repeat for each forward L/H and R/H, and Aft L/H and R/H crew dispense switch.	<p>Verify DCDU displays MANUAL6 DISPENSE, and then displays MANUAL6 DISP OFF.</p> <p>If DCDU does not display results, go to Task 16-5.11.</p>																																		
<p>NOTE</p> <p>The CDT has a battery saver feature which will turn the CDT off after approximately 20 minutes of inactivity. If this occurs, set CDT MODE switch (18) to OFF, then back to FIRE TEST.</p>		25. On landing gear status panel, place the landing gear switch to BYPASS.	<p>Verify DCDU displays WOW INACTIVE.</p> <p>If DCDU does not display results, go to Task 16-5.7.</p>																																		
18. Press the following DCDU INHIBIT pushbutton switches (24): O1, O2, CH, FL, RWR, JMR, and MWS.	<p>LED for each switch illuminates when the switch is depressed.</p> <p>If LED for any INHIBIT switch fails to illuminate, remove and replace DCDU.</p>	26. On landing gear status panel, place the landing gear switch to NORMAL.	<p>Verify DCDU displays WOW ACTIVE.</p> <p>If DCDU does not display results, go to Task 16-5.7.</p>																																		
19. Press and hold DCDU ENT/BIT switch until MAINTENANCE BIT is displayed, then release DCDU ENT/BIT switch to view BIT status.	<p>MAINTENANCE BIT, then BITSTAT=00000000 is displayed on DCDU.</p> <p>If DCDU does not display results, replace DCDU.</p>	27. On DCDU press and release the ENT/BIT switch.	<p>Verify payload inventory is displayed, and all payload and sensor inhibit light go out.</p> <p>If DCDU does not display results, replace DCDU.</p>																																		
20. Press and release DCDU ENT/BIT switch to view DCDU failures.	<p>NO CDU FAILURES is displayed on DCDU.</p> <p>If DCDU failures are displayed, replace DCDU.</p>																																				

GO TO NEXT PAGE

TASK	RESULT	TASK	RESULT
<p>NOTE</p> <p>Ensure all DCDU INHIBIT LEDs remain illuminated when performing steps 19 – 22.</p>		33. Press DCDU INHIBIT O1, O2, CH, FL, RWR, JMR, and MWS switches (24).	LED for each switch goes out as switch is depressed.
28. Press DCDU ENT/BIT switch (25) momentarily to select maintenance mode.	When IBIT is complete, MAINT MODE??? prompt will appear.	34. Ensure sequencer switches (43 and 44) are set as follows: No. 1 sequencer (32): 1/A; No. 2 sequencer (26): 2/A.	
29. While MAINT MODE??? is displayed, press DCDU ENT/BIT switch (25) momentarily to display the DCDU and sequencer firmware identification numbers.	The following displays appear: OFP # XXXX MDF # XXXX CCU FIRM ID ##### SEQ 1A ID ##### SEQ 2A ID ##### SEQ 1A SAFE SEQ 2A SAFE	35. Remove safety pin (30) from AN/ALE-47 safety switch (31).	
30. When HIST DATA??? appears, press DCDU ENT/BIT switch (23) momentarily.	System fault messages are displayed. Refer to table at end of this task for explanation of fault messages. After fault messages are displayed, CLR FLT LST is displayed.	36. Set LDG GR SW BYPASS switch (28) on LDG GR BYPASS STATUS panel (27) to BYPASS (up).	LDG GR SW BYPASS light (29) on LDG GR BYPASS STATUS panel illuminates. If LDG GR SW BYPASS light (29) on LDG GR BYPASS STATUS panel does not illuminate, troubleshoot per Task 16-5.13.
<p>NOTE</p> <p>The number (inventory) displayed on the DCDU will vary based on the number of CDTs being used to perform the AN/ALE-47 operational check.</p> <p><u>Examples:</u></p> <p>1 CDT installed: 10 10 __ 10 will be displayed 2 CDTs installed: 20 20 __ 20 will be displayed 3 CDTs installed: 30 30 __ 30 will be displayed 4 CDTs installed: 40 40 __ 40 will be displayed</p>		37. Set DCDU MODE switch (7) to MAN and MANUAL switch (6) to 1.	O1: 20 O2: 20 CH: __ FL: 20 is displayed on DCDU. If DCDU does not display full simulated payload module quantities, check DCDU for BIT failure messages. If no BIT failure messages are displayed, verify that CDTs are installed correctly and powered up.
<p>NOTE</p> <p>The CDT has a battery saver feature which will turn the CDT off after approximately 15 minutes of inactivity. If this occurs, set CDT MODE switch (18) to OFF, then back to FIRE TEST; press RESET TEST button.</p>		<p>NOTE</p> <p>Loose, damaged or dirty contacts for the fire pins and ground spring of the dispenser assemblies can cause misfires of the expendables.</p>	
31. Press DCDU ENT/BIT switch (25) momentarily after CLR FAULT LIST? prompt appears to clear the MFL.	O1: 20 O2: 20 CH: __ FL: 20 is displayed on DCDU.	38. Press and release FLARE DISP button (22) on pilot's cyclic stick grip (23) one time.	Expendable count on DCDU counts down by XX ; CDTs count up by XX . (NOTE: XX represents the expendable count as determined by the MDF loaded in the CMDS and the number of CDTs installed). If DCDU does not indicate correct dispense count, isolate faulty LRU; if CDT does not indicate correct count, go to Task 16-5.10.
<p>NOTE</p> <p>The CDT has a battery saver feature which will turn the CDT off after approximately 15 minutes of inactivity. If this occurs, set CDT MODE switch (18) to OFF, then back to FIRE TEST; press RESET TEST button.</p>		39. Dispense all remaining simulated payloads by repeatedly pressing FLARE DISP button (22).	O1: 0 O2: 0 CH: __ FL: 0 is displayed on DCDU; 30 is displayed on CDTs. If CDT does not show all expendables fired, isolate the faulty LRU; remove and replace LRU per TM 55-1520-240-23-10.
32. Adjust DCDU LED indicator (5) brightness from dim to bright; set as desired using ALE-47 dim switch (2) located on miscellaneous control panel (3).	DCDU LED indicator goes from bright to dim as lighting control switch is rotated.		

GO TO NEXT PAGE

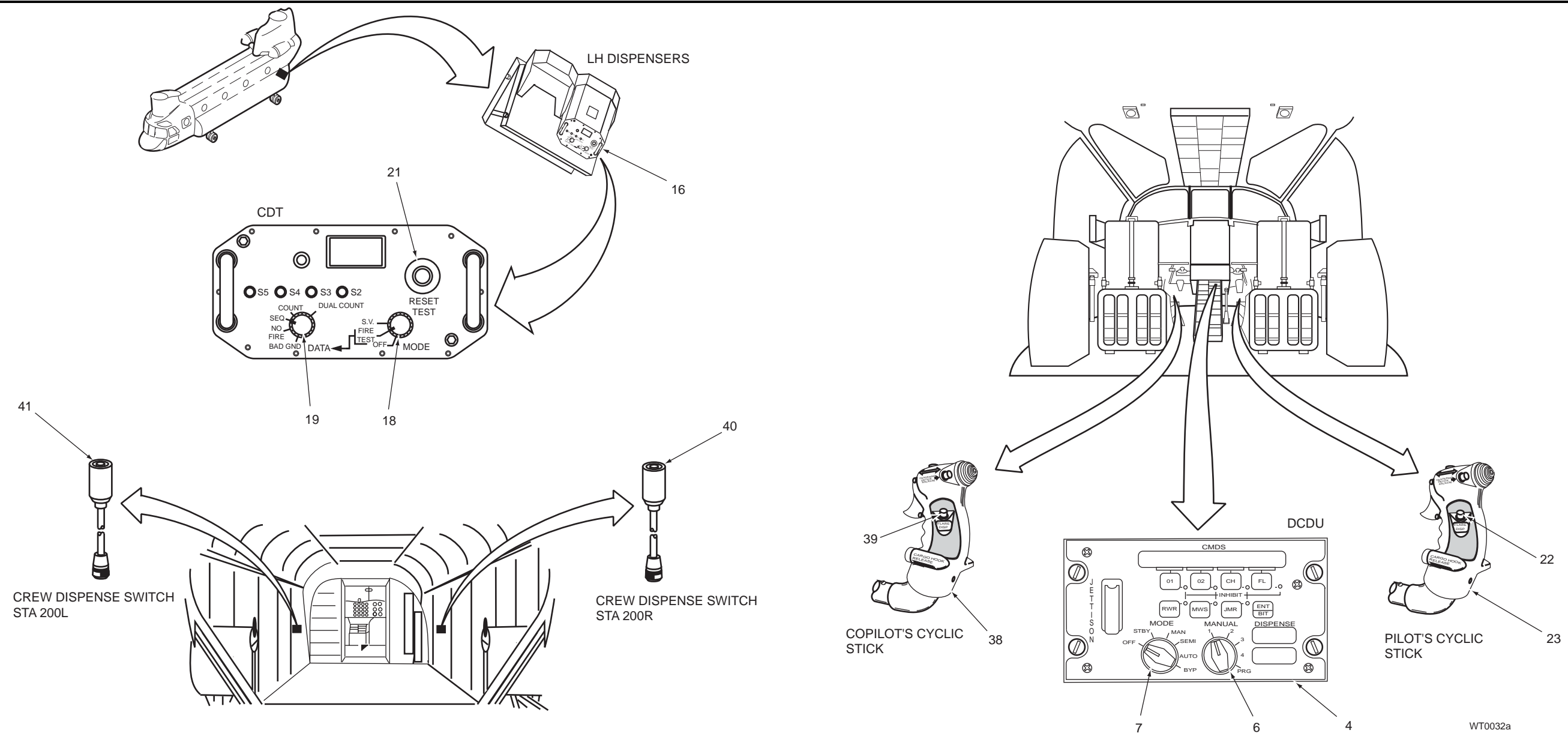

GO TO NEXT PAGE

TASK	RESULT	TASK	RESULT
40. Set CDT MODE switch (18) to FIRE TEST and DATA switch (19) to NO FIRE.	CDTs display PASS . If either CDT displays unfired pin numbers, check DCDCU for BIT failure messages to determine faulty LRU; refer to TM 55-1520-240-23-10 for LRU removal and replacement procedures.	49. Set DCDCU MODE switch (7) to OFF, then MAN; set DCDCU MANUAL switch (6) to 3; press RESET TEST switch (21) on CDTs (16).	O1: 20 O2: 20 CH:___ FL: 20 is displayed on DCDCU; 00 is displayed on CDTs. If DCDCU does not display full simulated payload module quantities, check DCDCU for BIT failure messages. If no BIT failure messages are displayed, verify that CDTs are installed correctly and powered up.
NOTE Record firing sequences as they are displayed on each CDT to compare them with the MDF programmed sequences.		50. Press and release FLARE DISP button (22) on pilot's cyclic stick grip (23).	Expendable count on DCDCU counts down by XX ; CDTs count up by XX . If DCDCU does not indicate correct dispense count, isolate faulty LRU; if CDT does not indicate correct count, go to Task 16-5.10.
41. Set CDT DATA switch (19) to SEQ to check detected firing sequences with the MDF sequences.	Firing sequence of expendables is displayed. If detected fire sequence is correct go to step 32. If detected firing sequence was incorrect, analyze CDT recorded test data and/or CMD5 BIT results to isolate faulty LRU. Refer to TM 55-1520-240-23-10 for LRU removal and replacement procedures.	51. Press and release FLARE DISP button (39) on copilot's cyclic stick grip (38).	Expendable count on DCDCU counts down by XX ; CDT LCD flare counts up by XX . If DCDCU does not indicate correct dispense count, isolate faulty LRU; if CDT does not indicate correct count, go to Task 16-5.9.
42. Set CDT DATA switch (19) to BAD GND.	CDT LCD main display field displays PASS . If CDT LCD displays Exx , isolate faulty LRU or cable; repair cable; or replace LRU per TM 55-1520-240-23-10.	52. Repeat steps 39 through 41 to verify correct expendable sequence IAW MDF for each operating mode; (MAN 1 through 4) SEMI, AUTO and the aft station dispense switches (manual mode 6).	
43. Set CDT DATA switch (19) to COUNT, press RESET TEST switch (21).	CDTs display 00 .	53. Set DCDCU MODE switch (7) to OFF, then MAN; set MANUAL switch (6) to 4; press RESET TEST switch (21) on CDTs (16).	O1: 20 O2: 20 CH:___ FL: 20 is displayed on DCDCU; 00 is displayed on CDTs. If DCDCU does not display full simulated payload module quantities, check DCDCU for BIT failure messages. If no BIT failure messages are displayed, verify that CDTs are installed correctly and powered up.
44. Set DCDCU MODE switch (7) to OFF, then to MAN.	O1: 20 O2: 20 CH: ___ FL: 20 is displayed on DCDCU.	54. Press and release FLARE DISP button (22) on pilot's cyclic stick grip (23).	Expendable count on DCDCU counts down by XX ; CDTs count up by XX . If DCDCU does not indicate correct dispense count, isolate faulty LRU; if CDT does not indicate correct count, go to Task 16-5.10.
45. Set DCDCU MANUAL switch (6) to 2.		55. Press and release FLARE DISP button (39) on copilot's cyclic stick grip (38).	Expendable count on DCDCU counts down by XX ; CDTs count up by XX . If DCDCU does not indicate correct dispense count, isolate faulty LRU; if CDT does not indicate correct count, go to Task 16-5.9.
46. Press and release FLARE DISP button (22) on pilot's cyclic stick grip (23).	Expendable count on DCDCU counts down by XX ; CDTs count up by XX . If DCDCU does not indicate correct dispense count, isolate faulty LRU; if CDT does not indicate correct count, go to Task 16-5.10.		
47. Press and release FLARE DISP button (39) on copilot's cyclic stick grip (38).	Expendable count on DCDCU counts down by XX ; CDTs count up by XX . If DCDCU does not indicate correct dispense count, isolate faulty LRU; if CDT does not indicate correct count, go to Task 16-5.9.		
48. Repeat steps 39 through 41 to verify correct expendable sequence IAW MDF for each operating mode; (MAN 1 through 4) SEMI, AUTO and the aft station dispense switches (manual mode 6).			

GO TO NEXT PAGE

16-5.3 AN/ALE-47 COUNTERMEASURES DISPENSER SYSTEM OPERATIONAL CHECK (Continued)

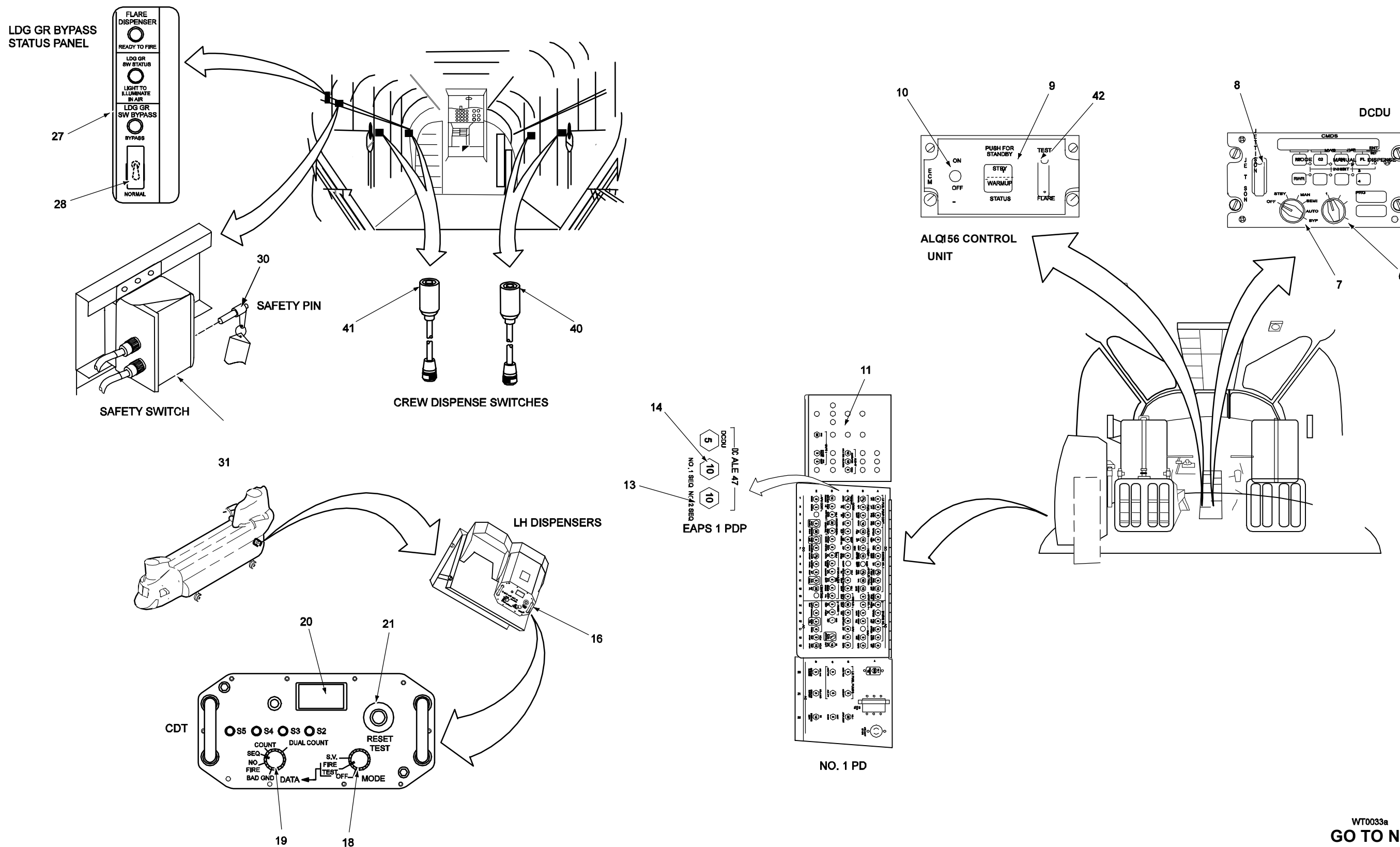

WT0033a
 GO TO NEXT PAGE

16-5.3 AN/ALE-47 COUNTERMEASURES DISPENSER SYSTEM OPERATIONAL CHECK (Continued)

TASK	RESULT	TASK	RESULT
56. Repeat steps 39 through 41 to verify correct expendable sequence IAW MDF for each operating mode; (MAN 1 through 4) SEMI, AUTO and the aft station dispense switches (manual mode 6).		65. Set DCDU MODE switch to (7) OFF, then AUTO; press RESET TEST switch (21) on CDTs (16).	O1:20 O2:20 CH:___ FL:20 is displayed on DCDU; 00 is displayed on CDTs.
57. Set DCDU MODE switch (7) to OFF, then MAN; press RESET TEST switch (21) on CDTs (16).	O1:20 O2:20 CH:___ FL:20 is displayed on DCDU; 00 is displayed on CDTs. If DCDU does not display full simulated payload module quantities, check DCDU for BIT failure messages. If no BIT failure messages are displayed, verify that CDTs are installed correctly and powered up.	66. Raise AN/ALQ-156 TEST FLARE switch guard and move switch (42) forward (on) and release.	If DCDU does not display full simulated payload module quantities, check DCDU for BIT failure messages. If no BIT failure messages are displayed, verify that CDTs are installed correctly and powered up. Expendable count on DCDU counts down by XX ; CDTs count up by XX .
58. Press and release four hand-held crew dispense switches (40 and 41) located in cabin at STA 200 and 400 left and right; observe DCDU and CDTs expendable counts after each switch is pressed.	Expendable count on DCDU counts down by XX ; CDTs count up by XX . If DCDU does not indicate correct dispense count, isolate faulty LRU; if CDT does not indicate correct count, go to Task 16-5.11.	67. Repeat steps 39 through 41 to verify correct expendable sequence IAW MDF for each operating mode; (MAN 1 through 4) SEMI, AUTO and the aft station dispense switches (manual mode 6).	If DCDU or CDT does not indicate correct expendable dispense count, isolate faulty LRU and replace per TM 55-1520-240-23-10.
59 Repeat steps 39 through 41 to verify correct expendable sequence IAW MDF for each operating mode; (MAN 1 through 4) SEMI, AUTO and the aft station dispense switches (manual mode 6).		68. Move AN/ALQ-156 TEST FLARE switch guard (42) to closed position.	
60. Set DCDU MODE switch (7) to OFF, then SEMI; press RESET TEST switch (21) on CDTs (16).	O1:20 O2:20 CH:___ FL:20 is displayed on DCDU; 00 is displayed on CDTs. If DCDU does not display full simulated payload module quantities, check DCDU for BIT failure messages. If no BIT failure messages are displayed, verify that CDTs are installed correctly and powered up.	69. Set DCDU MODE switch (7) to OFF, then MAN; press RESET TEST switch (21) on CDTs (16).	O1:20 O2:20 CH:___ FL:20 is displayed on DCDU. 00 is displayed on CDTs. If DCDU does not display full simulated payload module quantities, check DCDU for BIT failure messages. If no BIT failure messages are displayed, verify that CDTs are installed correctly and powered up.
61. Ensure AN/ALQ-156 POWER switch (10) is on and in standby mode	STBY light (9) on ALQ-156 control panel is illuminated.	70. Set AN/ALQ-156 power switch (10) to OFF.	
62. Raise AN/ALQ-156 TEST FLARE switch guard and move switch (42) forward (on) and release.	Expendable count on DCDU counts down by XX ; CDT LCD flare counts up by XX . If DCDU or CDT does not indicate correct expendable dispense count, isolate faulty LRU and replace per TM 55-1520-240-23-10.	71. Pull out AN/ALE-47 SQUIB PWR NO. #1 SEQ (14) and NO. #2 SEQ (13) circuit breakers located on EAPS 1 PDP (11).	
63. Repeat steps 39 through 41 to verify correct expendable sequence IAW MDF for each operating mode; (MAN 1 through 4) SEMI, AUTO and the aft station dispense switches (manual mode 6).		72. Set LDG GR SW BYPASS switch (28) LDG GR SW BYPASS panel (27) to NORMAL.	BYPASS light on LDG GR SW BYPASS STATUS panel (27) goes out.
64. Move AN/ALQ-156 TEST FLARE switch guard (42) to closed position.		73. Install safety pin (30) in AN/ALE-47 safety switch (31).	
		74. Raise DCDU JETTISON switch guard (8) and move switch to on (forward).	DCDU expendable count remains the same; CDT count stays at 00.
		75. Lower DCDU JETTISON switch guard (8).	
		76. Close AN/ALE-47 SQUIB PWR NO. #1 SEQ (14) and NO. #2 SEQ (13) circuit breakers on EAPS 1 PDP (11).	

GO TO NEXT PAGE

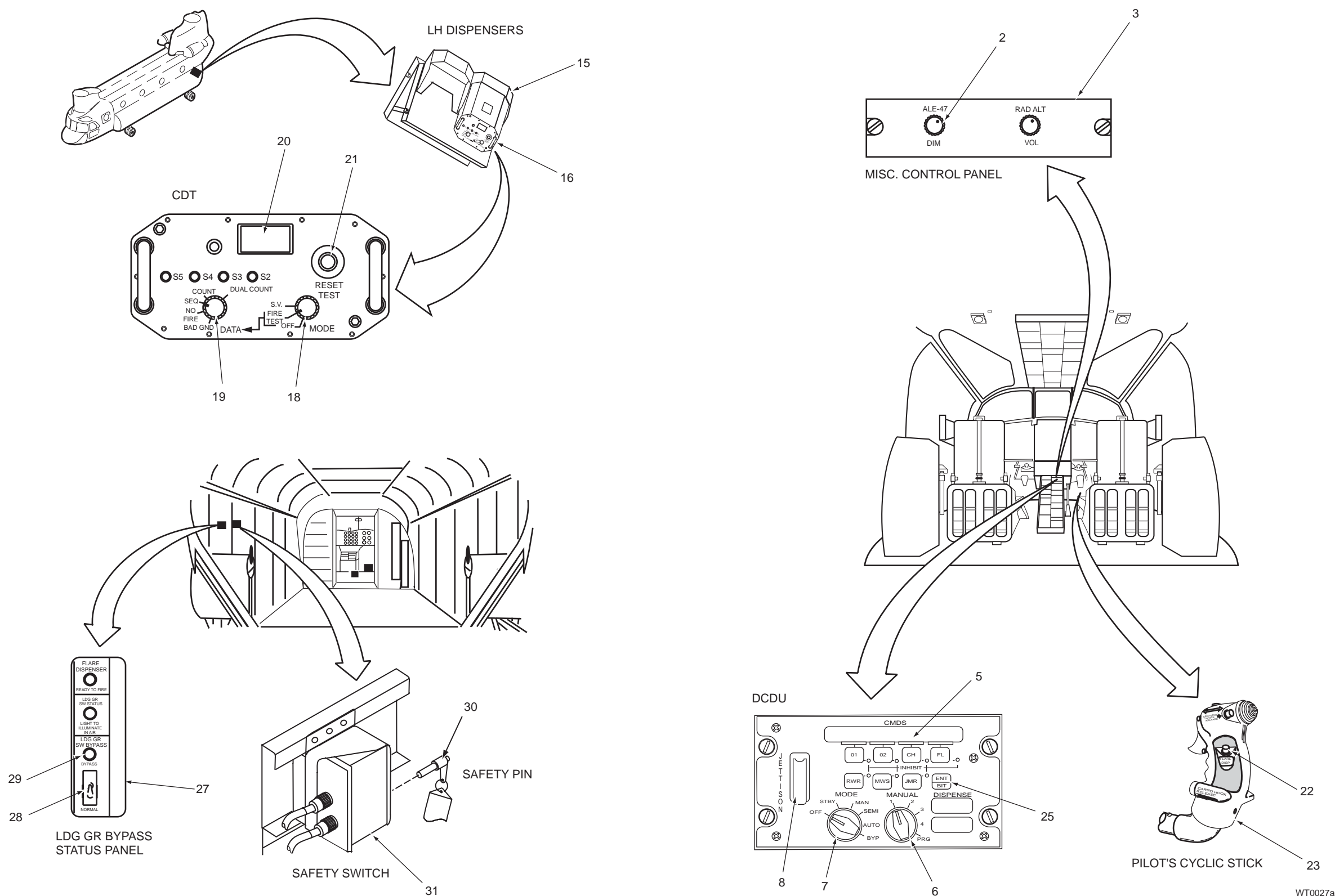

GO TO NEXT PAGE

16-5.3 AN/ALE-47 COUNTERMEASURES DISPENSER SYSTEM OPERATIONAL CHECK (Continued)

TASK	RESULT	TASK	RESULT
77. Raise DCDU JETTISON switch guard (8) and move switch to on (forward).	DCDU expendable count remains the same; CDT count stays at 00 .	90. Press and release FLARE DISP switch (22) on pilot's or copilot's cyclic grip (23).	DCDU displays remain blank; CDTs will count up by XX .
78. Lower DCDU JETTISON switch guard (8).		91. Set DCDU MODE switch (7) to OFF and then BYP; press RESET TEST switch (21) on CDTs (16).	DCDU displays remain blank; 00 is displayed on CDTs.
79. Set LDG GR BYPASS switch (28) on LDG GR SW BYPASS panel (27) to BYPASS.	BYPASS light on LDG GR SW BYPASS panel (27) illuminates.	92. Set DCDU JETTISON switch (8) to on (forward).	DCDU expendable displays remain blank; CDTs display 30-60 .
80. Raise DCDU JETTISON switch guard (8) and move switch to on (forward).	DCDU will count down and displays 01:0 02:0 CH:___ FL:0; 00 is displayed on CDTs.	93. Set DCDU JETTISON switch (8) to off (aft).	
81. Lower DCDU JETTISON switch guard (8) .		94. Set CDT MODE switch (18) to OFF.	
82. Set DCDU MODE switch (7) to OFF, then to MAN	01:0 02:0 CH:___ FL:0 is displayed on DCDU.	95. Set DCDU MODE switch (7) to OFF.	
83. Remove safety pin (30) from AN/ALE-47 safety switch (31).		96. Install safety pin (30) in AN/ALE-47 safety switch (31).	
84. Raise DCDU JETTISON switch guard (8) and move switch to on (forward).	DCDU counts down and 01:0 02:0 CH:___ FL:0 is displayed: 30-60 is displayed on CDTs.	97. Set LDG GR SW BYPASS switch (28) on LDG GR SW STATUS panel (27) to NORMAL.	BYPASS light (29) on LDG GR SW STATUS panel (28) goes out.
85. Lower DCDU JETTISON switch guard (8).		98. Remove electrical power from aircraft.	
86. Set DCDU MODE switch (7) to OFF; press RESET TEST switch (21) on CDTs (16).	DCDU display is blank; 00 is displayed on CDTs.	99. Remove CDTs (16) from dispenser assemblies (15).	
87. Raise DCDU JETTISON switch guard (8) and move switch to on (forward).	All INHIBIT lights illuminate momentarily; OFP and MDF numbers are displayed momentarily; JETTISON ON is displayed on DCDU; 01:0 02:0 CH:___ FL:0 is displayed on DCDU; 30-60 is displayed on CDTs.	100. Repeat AN/ALE-47 Countermeasures Dispenser System Operational Check on remaining dispenser assemblies, if required.	
88. Lower DCDU JETTISON switch guard (8).	01:0 02:0 CH:___ FL:0 displayed on DCDU goes out.		
NOTE			
DCDU MODE switch must be pressed while it is turned to access BYP (bypass) mode.			
89. Set DCDU MODE switch (7) to BYP; press RESET TEST switch (21) on CDTs (16).	DCDU displays are blank; 00 is displayed on CDTs.		

GO TO NEXT PAGE

16-5.3 AN/ALE-47 COUNTERMEASURES DISPENSER SYSTEM OPERATIONAL CHECK (Continued)

16-5.3

PFL Message	MFL Message	Failure	Effect On System
SEMI FAIL AUTO FAIL	N/A	Loss of Track file Data	N/A *
N/A	SEQ ## SAFE	No Sequencer Squib Power (Safety Switch)	Unable to Dispense
SEQ ## FAIL	N/A	Sequencer Communications Failure	Loss of Sequencer
PROG FAIL GO BYP	PROG FAIL A1 01	Instruction Set	Loss of Programmer
PROG FAIL GO BYP	PROG FAIL A1 02	Internal Timer A	Loss of Programmer
PROG FAIL GO BYP	PROG FAIL A1 03	Internal Timer B	Loss of Programmer
PROG FAIL GO BYP	PROG FAIL A1 04	RAM High Byte	Loss of Programmer
PROG FAIL GO BYP	PROG FAIL A1 05	RAM Low Byte	Loss of Programmer
PROG FAIL GO BYP	PROG FAIL A1 06	PBIT Timer-A >chk_timers=routine	Loss of Programmer
PROG FAIL GO BYP	PROG FAIL A1 07	Interrupt Test	Loss of Programmer
PROG FAIL GO BYP	PROG FAIL A1 08	PBIT Local RAM High Byte	Loss of Programmer
PROG FAIL GO BYP	PROG FAIL A1 09	PBIT Local RAM Low Byte	Loss of Programmer
PROG FAIL GO BYP	PROG FAIL A1 10	OFF EEPROM Checksum	Loss of Programmer
PROG FAIL GO BYP	PROG FAIL A1 11	PBIT Timer-A >tim_tst=routine	Loss of Programmer
PROG FAIL GO BYP	PROG FAIL A1 12	OFF RAM High Byte	Loss of Programmer
PROG FAIL GO BYP	PROG FAIL A1 13	OFF RAM Low Byte	Loss of Programmer
PROG FAIL GO BYP	PROG FAIL A1 14	OFF RAM Checksum	Loss of Programmer
PROG FAIL GO BYP	PROG FAIL A1 15	RAM BIT MAP High Byte	Loss of Programmer
PROG FAIL GO BYP	PROG FAIL A1 16	RAM BIT MAP Low Byte	Loss of Programmer
PROG FAIL GO BYP	PROG FAIL A1 17	Checksum PBT_MAIN EEPROM	Loss of Programmer
PROG FAIL GO BYP	PROG FAIL A1 19	Checksum PBT_MAIN RAM	Loss of Programmer
PROG FAIL GO BYP	PROG FAIL A1 22	Checksum MDF EEPROM	Loss of Programmer
PROG FAIL GO BYP	PROG FAIL A1 23	Checksum MDF RAM	Loss of Programmer
PROG FAIL GO BYP	PROG FAIL A1 24	RAM Test MDF RAM High Byte	Loss of Programmer
PROG FAIL GO BYP	PROG FAIL A 1 25	RAM Test MDF RAM Low Byte	Loss of Programmer
PROG FAIL GO BYP	PROG FAIL A1 26	MMU Power up Configuration	Loss of Programmer
PROG FAIL GO BYP	PROG FAIL A1 27	MMU Instruction Pg Write Affects Operand Pg	Loss of Programmer
PROG FAIL GO BYP	PROG FAIL A1 28	MMU Operand Pg Write Affects Instruction Pg	Loss of Programmer
PROG FAIL GO BYP	PROG FAIL A1 36	Timer A Failure Detected By CBIT	Loss of Programmer
PROG FAIL GO BYP	PROG FAIL A1 37	H/W Reset Due to Watchdog Timer Logic	Loss of Programmer
PROG FAIL GO BYP	PROG FAIL A1 38	Polling Execution Timeout	Loss of Programmer
PROG FAIL GO BYP	PROG FAIL A1 39	CBIT Execution Timeout	Loss of Programmer
PROG FAIL GO BYP	PROG FAIL A1 40	Address FFFF Corruption	Loss of Programmer
PROG FAIL GO BYP	PROG FAIL A1 41	Machine Error Detected	Loss of Programmer
SEMI FAIL	PROG FAIL A2 01	Discrete Output Line 1	Semi-Auto Disp Ready Output Fail *
N/A	PROG FAIL A2 02	Discrete Output Line 2	Ready Discrete Output Fail *
PROG FAIL DEG	PROG FAIL A2 03	Discrete Output Line 3	BIT Fail Output Fail *
PROG FAIL GO BYP	PROG FAIL A2 04	Back plane Test	Loss of Programmer *

PFL Message	MFL Message	Failure	Effect On System
PROG FAIL DEG	PROG FAIL A2 05	Power Sense	Programmer Degraded *
PROG FAIL DEG	PROG FAIL A2 06	Watch Dog Timer	Programmer Degraded
MWS JMR FAIL	PROG FAIL A2 08	Discrete Input 1 Line 1	MWS 1/JMR 1 Input Fail *
MWS JMR FAIL	PROG FAIL A2 09	Discrete Input 1 Line 2	MWS 2/JMR 2 Input Discrete Fail *
MWS JMR FAIL	PROG FAIL A2 10	Discrete Input 1 Line 3	MWS 3/JMR 3 Input Discrete Fail *
MWS JMR FAIL	PROG FAIL A2 11	Discrete Input 1 Line 4	MWS 4/JMR 4 Input Discrete Fail *
MWS JMR FAIL	PROG FAIL A2 12	Discrete Input 1 Line 5	JMR 5 Input Discrete Fail *
MWS JMR FAIL	PROG FAIL A2 13	Discrete Input 1 Line 6	JMR 6 Input Discrete Fail *
PROG JET INPT FAIL	PROG FAIL A2 14	Discrete Input 1 Line 7	Jettison Input Discrete Fail *
N/A	PROG FAIL A2 15	Discrete Input 1 Line 8	LV Present Input Discrete Fail *
BUMP FAIL	PROG FAIL A2 16	Discrete Input 1 Line 9	Manual 5 Dispense Input Discrete Fail *
MAN FAIL	PROG FAIL A2 17	Discrete Input 1 Line 10	Manual Initiate Input Discrete Fail *
PROG FAIL GO BYP	PROG FAIL A2 18	Discrete Input 1 Line 11	WOW Input Dispense Discrete Fail
SEMI FAIL	PROG FAIL A2 19	Discrete Input 1 Line 12	Semi-Auto Dispense Discrete Fail
PROG FAIL GO BYP	PROG FAIL A2 22	UART Channel 1 Internal Loop Back	Loss of CDU Data Link
PROG FAIL GO BYP	PROG FAIL A2 23	UART Channel 1 External Loop Back	Loss of CDU Data Link
PROG FAIL GO BYP	PROG FAIL A2 24	UART Channel 1 Operational Comm Failure	Loss of CDU Data Link
PROG FAIL GO BYP	PROG FAIL A2 25	UART Channel 2 Internal Loop Back	Loss of Sequencer Data Link
PROG FAIL GO BYP	PROG FAIL A2 26	UART Channel 2 External Loop Back	Loss of Sequencer Data Link
PROG FAIL CHK BYP	PROG FAIL A2 27	UART Channel 2 Operational Comm Failure	Loss of Sequencer Data Link
ADAT FAIL	PROG FAIL A2 29	UART Channel 3 Internal Loop Back	Loss of Data Link *
ADAT FAIL	PROG FAIL A2 30	UART Channel 3 External Loop Back	Loss of Data Link *
ADAT FAIL	PROG FAIL A2 31	UART Channel 3 Operational Comm Failure	Loss of Data Link *
BDAT FAIL	PROG FAIL A2 32	UART Channel 4 Internal Loop Back	Loss of Data Link *
BDAT FAIL	PROG FAIL A2 33	UART Channel 4 External Loop Back	Loss of Data Link *
BDAT FAIL	PROG FAIL A2 34	UART Channel 4 Operational Comm Failure	Loss of Data Link *

GO TO NEXT PAGE

16-5.3 AN/ALE-47 COUNTERMEASURES DISPENSER SYSTEM OPERATIONAL CHECK (Continued)

PFL Message	MFL Message	Failure	Effect On System
PROG FAIL GO BYP	PROG FAIL A2 36	Discrete Input 3 Line 1 (AC ID Address 0)	Loss of Programmer
PROG FAIL GO BYP	PROG FAIL A2 37	Discrete Input 3 Line 2 (AC ID Address 1)	Loss of Programmer
PROG FAIL GO BYP	PROG FAIL A2 38	Discrete Input 3 Line 3 (AC ID Address 2)	Loss of Programmer
PROG FAIL GO BYP	PROG FAIL A2 39	Discrete Input 3 Line 4 (AC ID Address 3)	Loss of Programmer
PROG FAIL GO BYP	PROG FAIL A2 40	Discrete Input 3 Line 5 (AC ID Address 4)	Loss of Programmer
PROG FAIL GO BYP	PROG FAIL A2 41	Discrete Input 3 Line 6 (AC ID Address 5)	Loss of Programmer
PROG FAIL GO BYP	PROG FAIL A2 42	Discrete Input 3 Line 7 (AC ID Address 6)	Loss of Programmer
PROG FAIL GO BYP	PROG FAIL A2 43	Discrete Input 3 Line 8 (AC ID Address 7)	Loss of Programmer
AUTO DEG	PROG FAIL A3 01	EW Bus Address Latch	Loss of EW Interface *
AUTO DEG	PROG FAIL A3 02	EW Bus Test Latch	Loss of EW Interface *
AUTO DEG	PROG FAIL A3 03	EW Bus Time Tag Register	Loss of EW Interface *
AUTO DEG	PROG FAIL A3 04	EW Bus Base Pointer Register	Loss of EW Interface *
AUTO DEG	PROG FAIL A3 05	EW Bus A/B Mode Select	Loss of EW Interface *
AUTO DEG	PROG FAIL A3 06	EW Bus Last Command Register	Loss of EW Interface *
AUTO DEG	PROG FAIL A3 07	EW Bus Control Register	Loss of EW Interface *
AUTO DEG	PROG FAIL A3 08	EW Bus A Mode Chnl A Command Test	Loss of EW Interface A Channel *
AUTO DEG	PROG FAIL A3 09	EW Bus A Mode Chnl A RT Address Test	Loss of EW Interface A Channel *
AUTO DEG	PROG FAIL A3 10	EW Bus A Mode Chnl A Invalid Mode Code Tst	Loss of EW Interface A Channel *
AUTO DEG	PROG FAIL A3 11	EW Bus A Mode Chnl B Command Test	Loss of EW Interface A Channel *
AUTO DEG	PROG FAIL A3 12	EW Bus A Mode Chnl BRT Address Test	Loss of EW Interface A Channel *
AUTO DEG	PROG FAIL A3 13	EW Bus A Mode Chnl B Invalid Mode Code Tst	Loss of EW Interface A Channel *
AUTO DEG	PROG FAIL A3 14	EW Bus Operational Status Register	Loss of EW Interface A Channel *
AUTO DEG	PROG FAIL A3 15	EW Bus B Mode Chnl A Command Test	Loss of EW Interface B Channel *
AUTO DEG	PROG FAIL A3 16	EW Bus B Mode Chnl B RT Address Test	Loss of EW Interface B Channel *
AUTO DEG	PROG FAIL A3 17	EW Bus B Mode Chnl A Invalid Mode Code Tst	Loss of EW Interface B Channel *
AUTO DEG	PROG FAIL A3 18	EW Bus B Mode Chnl B Command Test	Loss of EW Interface B Channel *

PFL Message	MFL Message	Failure	Effect On System
AUTO DEG	PROG FAIL A3 19	EW Bus B Mode Chnl B RT Address Test	Loss of EW Interface B Channel *
AUTO DEG	PROG FAIL A3 20	EW Bus B Mode Chnl B Invalid Mode Code Tst	Loss of EW Interface B Channel *
AUTO DEG	PROG FAIL A3 21	EW Bus Operational Status Register	Loss of EW Interface B Channel *
AUTO FAIL GO MAN	PROG EW COMM FAIL	EW Bus Operational Communications Failure	Loss of AV Interface *
AUTO FAIL GO MAN	PROG FAIL A4 01	AV Bus Address Latch	Loss of AV Interface *
AUTO FAIL GO MAN	PROG FAIL A4 02	AV Bus Test Latch	Loss of AV Interface *
AUTO FAIL GO MAN	PROG FAIL A4 03	AV Bus Time Tag Register	Loss of AV Interface *
AUTO FAIL GO MAN	PROG FAIL A4 04	AV Bus Base Point Register	Loss of AV Interface *
AUTO FAIL GO MAN	PROG FAIL A4 05	AV Bus A/B Mode Select	Loss of AV Interface *
AUTO FAIL GO MAN	PROG FAIL A4 06	AV Bus Last Cmd Register	Loss of AV Interface *
AUTO FAIL GO MAN	PROG FAIL A4 07	AV Bus Control Register	Loss of AV Interface *
AUTO FAIL GO MAN	PROG FAIL A4 08	AV Bus A Mode Chnl A Command Test	Loss of AV Interface A Channel *
AUTO FAIL GO MAN	PROG FAIL A4 09	AV Bus A Mode Chnl A RT Address Test	Loss of AV Interface A Channel *
AUTO FAIL GO MAN	PROG FAIL A4 10	AV Bus A Mode Chnl A Invalid Mode Code Tst	Loss of AV Interface A Channel *
AUTO FAIL GO MAN	PROG FAIL A4 11	AV Bus A Mode Chnl B Command Test	Loss of AV Interface A Channel *
AUTO FAIL GO MAN	PROG FAIL A4 12	AV Bus A Mode Chnl B RT Address Test	Loss of AV Interface A Channel *
AUTO FAIL GO MAN	PROG FAIL A4 13	AV Bus A Mode Chnl B Invalid Mode Code Tst	Loss of AV Interface A Channel *
AUTO FAIL GO MAN	PROG FAIL A4 14	AV Bus Operational Status Register	Loss of AV Interface A Channel *
AUTO FAIL GO MAN	PROG FAIL A4 15	AV Bus B Mode Chnl A Command Test	Loss of AV Interface B Channel *
AUTO FAIL GO MAN	PROG FAIL A4 16	AV Bus B Mode Chnl A RT Address Test	Loss of AV Interface B Channel *
AUTO FAIL GO MAN	PROG FAIL A4 17	AV Bus B Mode Chnl A Invalid Mode Code Tst	Loss of AV Interface B Channel *
AUTO FAIL GO MAN	PROG FAIL A4 18	AV Bus B Mode Chnl B Command Test	Loss of AV Interface B Channel *
AUTO FAIL GO MAN	PROG FAIL A4 19	AV Bus B Mode Chnl B RT Address Test	Loss of AV Interface B Channel *
AUTO FAIL GO MAN	PROG FAIL A4 20	AV Bus B Mode Chnl B Invalid Mode Code Tst	Loss of AV Interface B Channel *
AUTO FAIL GO MAN	PROG FAIL A4 21	AV Bus Operational Status Register	Loss of AV Interface B Channel *

GO TO NEXT PAGE

16-5.3 AN/ALE-47 COUNTERMEASURES DISPENSER SYSTEM OPERATIONAL CHECK (Continued)

16-5.3

PFL Message	MFL Message	Failure	Effect On System
AUTO FAIL GO MAN	PROG AV COMM FAIL	AV Bus Operational Communications Failure	Loss of AV Interface *
N/A	CDU FAIL A1 01	Power Fail Detection	Loss of CDU
N/A	CDU FAIL A1 02	Watch Dog Timer	Loss of CDU
CDU FAIL GO BYP	CDU FAIL A1 03	ROM Checksum	Loss of CDU
CDU FAIL GO BYP	CDU FAIL A1 04	CPU Failure	Loss of CDU
N/A	CDU FAIL A1	SRU 1 (CPU)	Loss of CDU
MAN DISP 1-4 FAIL	CDU FAIL A2 01	Manual Dispense Input Discrete	Loss of Manual Dispense Input to CDU
SEMI FAIL	CDU FAIL A2 02	Semi-Automatic Dispense Input Discrete	Loss of Semi Auto Dispense Input to CDU
CDU BUMP FAIL	CDU FAIL A2 03	Manual 5 Dispense Input Discrete	Loss of Manual 5 Dispense Input to CDU
CDU FAIL GO BYP	CDU FAIL A2 04	Weight On Wheels Discrete Input	Loss of WOW Input to CDU *
CDU FAIL MAN-6	CDU FAIL A2 05	Manual 6 Discrete Input	Loss of Manual 6 Dispense Input to CDU
N/A	CDU FAIL A2 06	Cockpit Data Link	Loss of CDU
N/A	CDU FAIL A2	SRU 2 (Discrete I/O)	Loss of CDU
DISPLAY DEGRADED	CDU FAIL A3 01	Display	Loss of CDU Display
CDU FAIL GO BYP	CDU FAIL A3 02	External RAM	Loss of CDU
CH ENAB SW FAIL	CDU FAIL A3 03	Chaff Inhibit Switch	Loss of Chaff Inhibit
FL ENAB SW FAIL	CDU FAIL A3 04	Flare Inhibit Switch	Loss of Flare Inhibit
01 ENAB SW FAIL	CDU FAIL A3 05	Other 1 Inhibit Switch	Loss of Other 1 Inhibit
02 ENAB SW FAIL	CDU FAIL A3 06	Other 2 Inhibit Switch	Loss of Other 2 Inhibit
RWR ENAB SW FAIL	CDU FAIL A3 07	RWR Inhibit Switch	Loss of RWR Inhibit
JMR ENAB SW FAIL	CDU FAIL A3 08	Jammer Inhibit Switch	Loss of Jammer Inhibit
MWS ENAB SW FAIL	CDU FAIL A3 09	MWS Inhibit Switch	Loss of MWS Inhibit
REM BYP FAIL	CDU FAIL A3 10	Remote BYP	Loss of Remote BYP *
REM JET FAIL	CDU FAIL A3 11	Remote Jettison	Loss of Remote Jettison *
REM PROG FAIL	CDU FAIL A3 12	Remote Program	Loss of Remote Program *
REM MODE FAIL	CDU FAIL A3 13	Remote Mode	Loss of Remote Mode *
JETT FAIL	CDU FAIL A3 14	Jettison Switch	Loss of Jettison Switch
MAN FAIL CHG PROG	CDU FAIL A3 15	Program Switch	Loss of Program Switch
N/A	CDU FAIL A3 16	Mode Switch	Loss of CDU
CDU FAIL REM	CDU FAIL A3 17	Remote Control	Loss of Remote Control Input *
CDU FAIL GO BYP	CDU FAIL A3 18	Switch buffer	Loss of CDU
N/A	CDU FAIL A3	SRU 3 (Front Panel)	Loss of CDU
SEQ ## INV DEG	SEQ ## MAGA FAIL	Magazine A	MAG A Functional Fault (Misfire/Polling)
SEQ ## INV DEG	SEQ ## MAGB FAIL	Magazine B	MAG B Functional Fault (Misfire/Polling) *
SEQ ## BYP DEG	SEQ ## A1 01	BYP Flare Dispense	BYP Flare Dispense Loss
SEQ ## BYP DEG	SEQ ## A1 02	BYP Other 1 Dispense	BYP Other 1 Dispense Loss *
SEQ ## BYP DEG	SEQ ## A1 03	BYP Other 2 Dispense	BYP Other 2 Dispense Loss *
SEQ ## INV DEG	SEQ ## A1 04	Magazine A ID Register	Loss of Magazine

PFL Message	MFL Message	Failure	Effect On System
SEQ ## INV DEG	SEQ ## A1 05	Magazine B ID Register	Loss of Magazine
SEQ ## BYP DEG	SEQ ## A1 06	Other 1 Cascade/Magazine Sense B	BYP Other 1 Cascade/MAG B Test Fail *
SEQ ## BYP DEG	SEQ ## A1 07	Other 2 Cascade	BYP Other 2 Cascade Test Failure *
SEQ ## BYP DEG	SEQ ## A1 08	Flare Cascade Relay Closed	Flare BYP Cascade Failure
SEQ ## BYP DEG	SEQ ## A1 09	Flare Cascade Relay Open	Flare BYP Cascade Failure
SEQ ## BYP DEG	SEQ ## A1 10	Chaff Cascade Relay Closed	Chaff BYP Cascade Failure
SEQ ## BYP DEG	SEQ ## A1 11	Chaff Cascade Relay Open	Chaff BYP Cascade Failure
SEQ ## BYP DEG	SEQ ## A1 12	Chaff Dispense	BYP Chaff Dispense Loss
SEQ ## INV DEG	SEQ ## A1 13	EEPROM Write	Sequencer MDF Loss
SEQ ## BYP DEG	SEQ ## A1 15	Other 2 Relay Closed	Other 2 Cascade Failure *
SEQ ## BYP DEG	SEQ ## A1 16	Other 2 Relay Open	Other 2 Cascade Failure *
SEQ ## BYP DEG	SEQ ## A1 17	Other 1 Relay Closed	Other 1 Cascade Failure *
SEQ ## BYP DEG	SEQ ## A1 18	Other 1 Relay Open	Other 1 Cascade Failure *
SEQ ## OP FAIL	SEQ ## A1 21	High Squib Power	Unable to Sense High Squib Power
SEQ ## INV DEG	SEQ ## A1 22	Squib Power Present	Loss of Sequencer
SEQ ## INV DEG	SEQ ## A1 23	Squib Power High/Low	Loss of Sequencer
SEQ ## INV DEG	SEQ ## A1 24	Fire Current Status	Loss of Sequencer
SEQ ## BYP FAIL	SEQ ## A1 25	BYP Discrete	Loss of BYP Function
SEQ ## JETT FAIL	SEQ ## A1 26	Jettison Discrete	Loss of BYP Jettison
SEQ ## INV DEG	SEQ ## A1 27	MAG Present	Loss of MAG A Inventory
SEQ ## INV DEG	SEQ ## A1 28	MAG Present	Loss of MAG B Inventory *
SEQ ## FAIL	SEQ ## A1	Control I/O (Signal Conditioner)	Loss of Sequencer
SEQ ## INV DEG	SEQ ## A2 08	Fire Mux D	Sequencer Loss of Inventory/Dispenser
SEQ ## INV DEG	SEQ ## A2 09	Fire Mux C	Sequencer Loss of Inventory/Dispenser
SEQ ## INV DEG	SEQ ## A2 10	Fire Mux B	Sequencer Loss of Inventory/Dispenser
SEQ ## INV DEG	SEQ ## A2 11	Fire Mux A	Sequencer Loss of Inventory/Dispenser
EQ ## FAIL	SEQ ## A2	MUX	Loss of Inventory
SEQ ## INV DEG	SEQ ## A3 01	Fire Source D	Loss of Inventory
SEQ ## INV DEG	SEQ ## A3 02	Fire Source C	Loss of Inventory
SEQ ## INV DEG	SEQ ## A3 03	Fire Source B	Loss of Inventory
SEQ ## INV DEG	SEQ ## A3 04	Fire Source A	Loss of Inventory
SEQ ## OP FAIL	SEQ ## A3 05	Fire Source A Inhibit	Sequencer Safety Feature Fail
SEQ ## INV DEG	SEQ ## A3 06	Fire Source A Low Fire	Loss of Inventory
SEQ ## INV DEG	SEQ ## A3 07	Poll High/Low	Loss of MAG B Inventory *
SEQ ## OP FAIL	SEQ ## A3 08	Fire Source D Inhibit	Sequencer Safety Feature Fail
SEQ ## OP FAIL	SEQ ## A3 09	Fire Source D Low Fire	Loss of Inventory
SEQ ## OP FAIL	SEQ ## A3 10	Fire Source C Inhibit	Sequencer Safety Feature Fail

GO TO NEXT PAGE

PFL Message	MFL Message	Failure	Effect On System
SEQ ## INV DEG	SEQ ## A3 11	Fire Source C Low Fire	Loss of Inventory
SEQ ## OP FAIL	SEQ ## A3 12	Fire Source B Inhibit	Sequencer Safety Feature Fail
SEQ ## INV DEG	SEQ ## A3 13	Fire Source B Low Fire	Loss of Inventory
SEQ ## INV DEG	SEQ ## A3 14	Poll Leakage	Loss of Inventory
SEQ ## FAIL	SEQ ## A3	Fire Source	Loss of Inventory

* Refers to AN/ALE-47 feature not used with M-130 dispensers.

END OF TASK

16-5.4 DCDU CIRCUIT BREAKER WILL NOT STAY CLOSED

FAULT ISOLATION PROCEDURE

INITIAL SETUP

Personnel Required:
Avionics Mechanic

Applicable Configurations:
All

References:
TM 55-1520-240-23

Tools:
Electronic Equipment Tool Kit,
NSN 5180-00-064-5178

Equipment Conditions:
TM 55-1520-240-23:
Battery Disconnected
Electrical Power Off
Hydraulic Power Off

Materials:
None

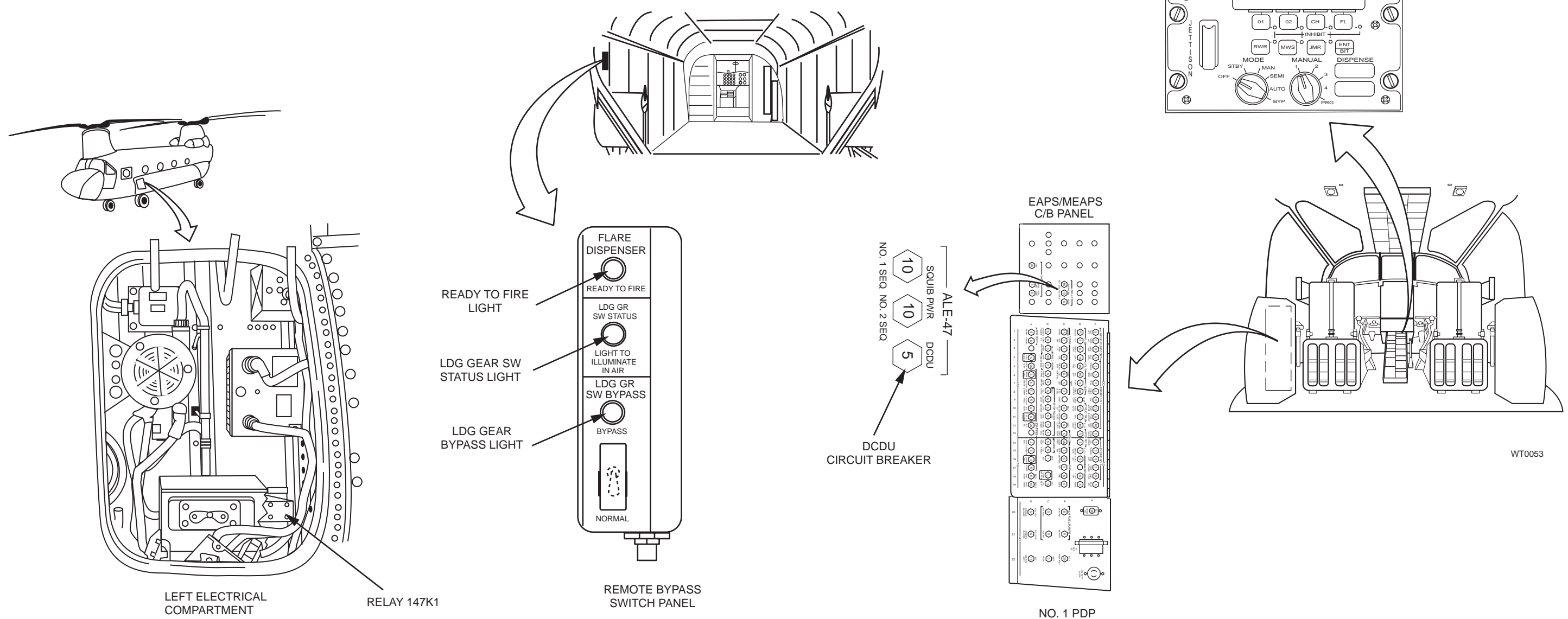

GO TO NEXT PAGE

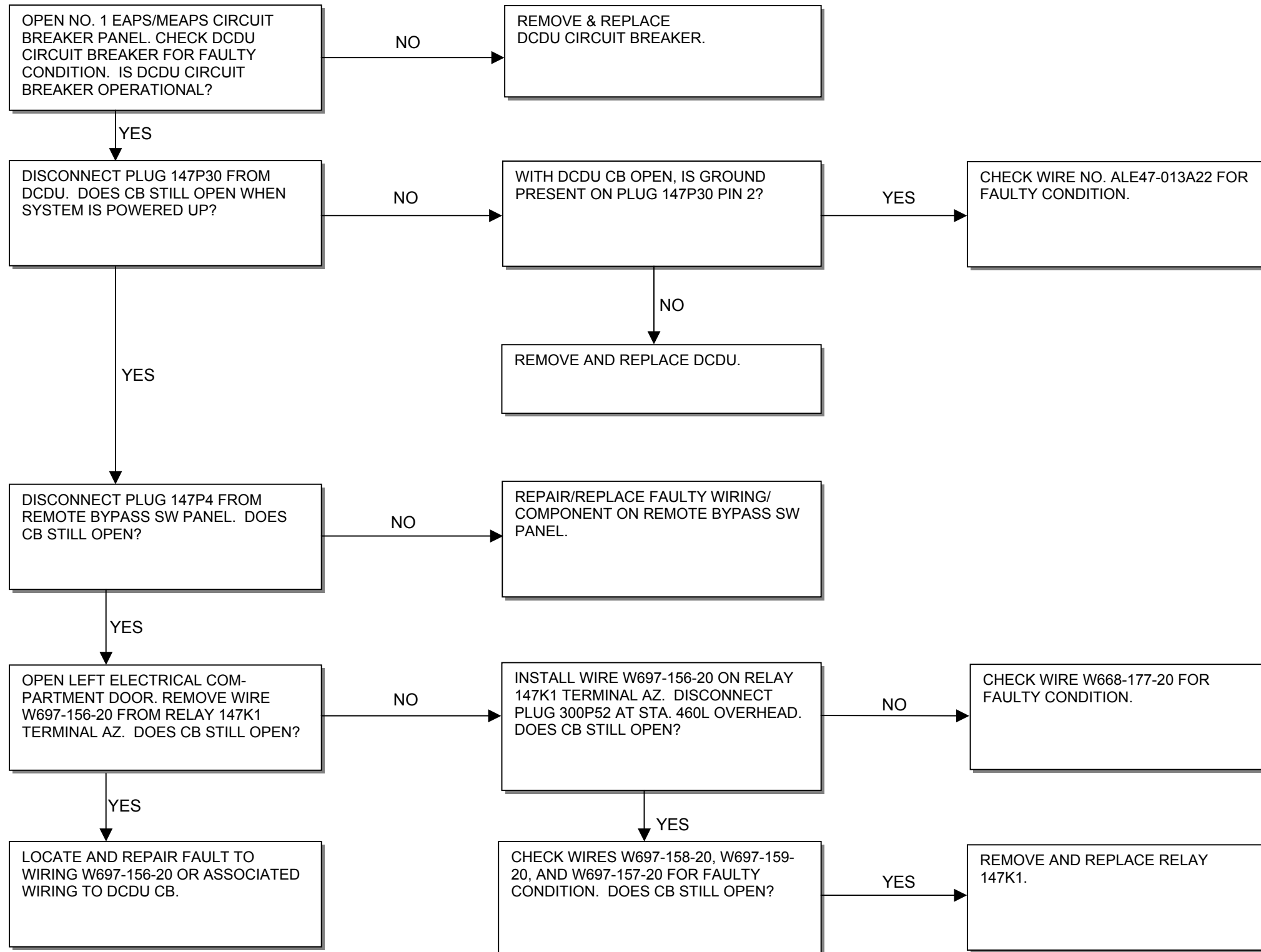

END OF TASK

16-5.5 LANDING GEAR SWITCH STATUS LIGHT IS ON

FAULT ISOLATION PROCEDURE

INITIAL SETUP

Personnel Required:
Avionics Mechanic

Applicable Configurations:

All

References:

TM 55-1520-240-23

Tools:

Electronic Equipment Tool Kit,
NSN 5180-00-064-5178

Equipment Conditions:

TM 55-1520-240-23:
Battery Connected
Electrical Power On
Hydraulic Power Off

Materials:

None

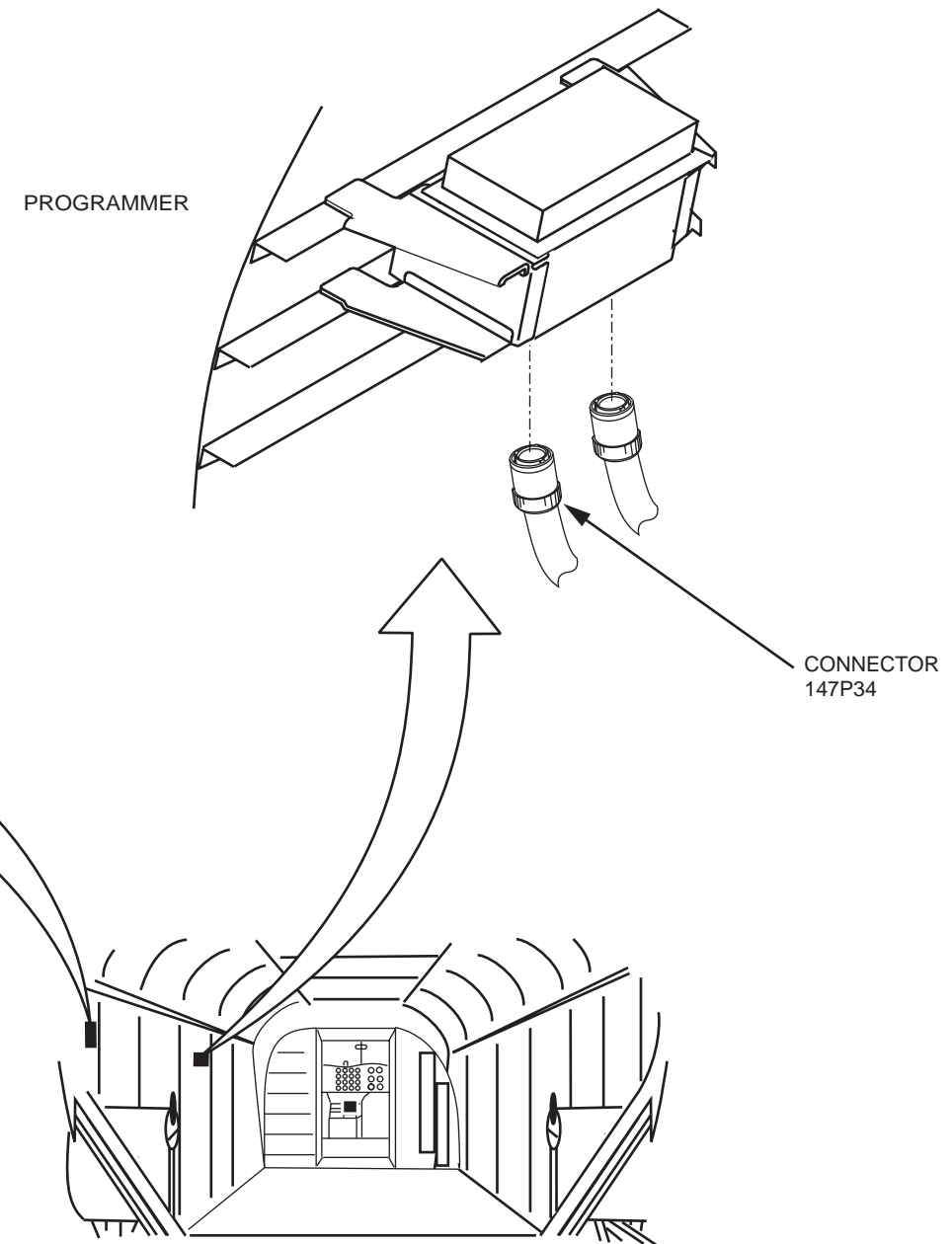
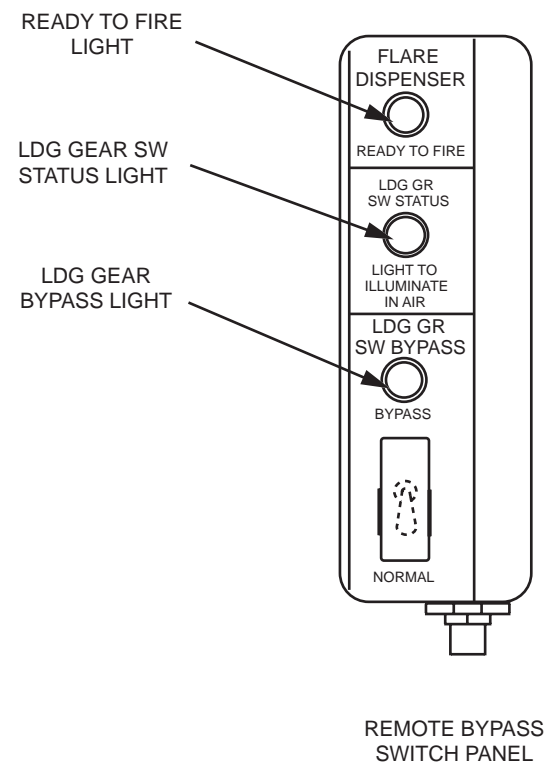
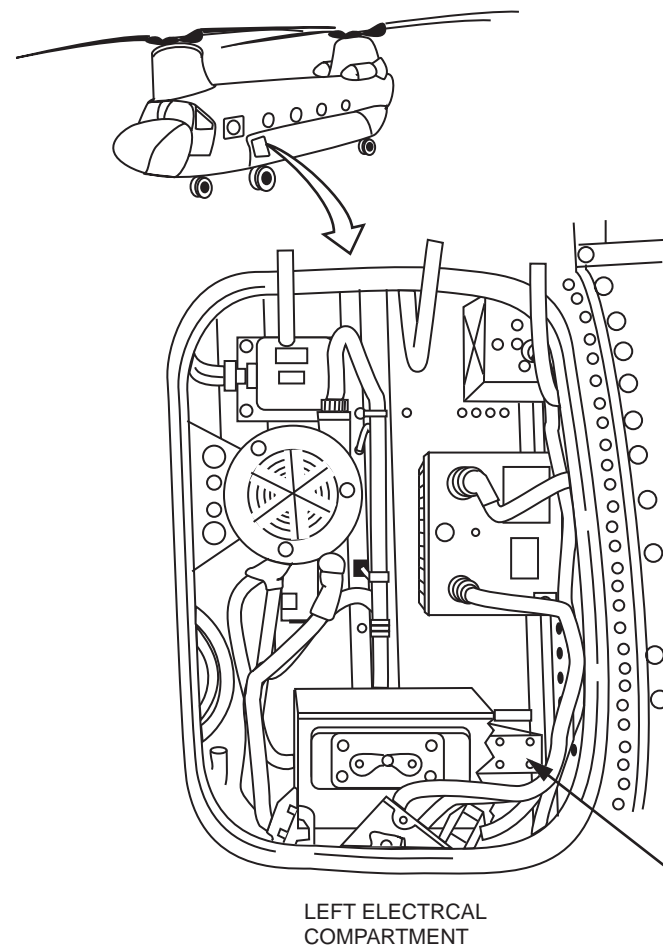

WT0056

GO TO NEXT PAGE

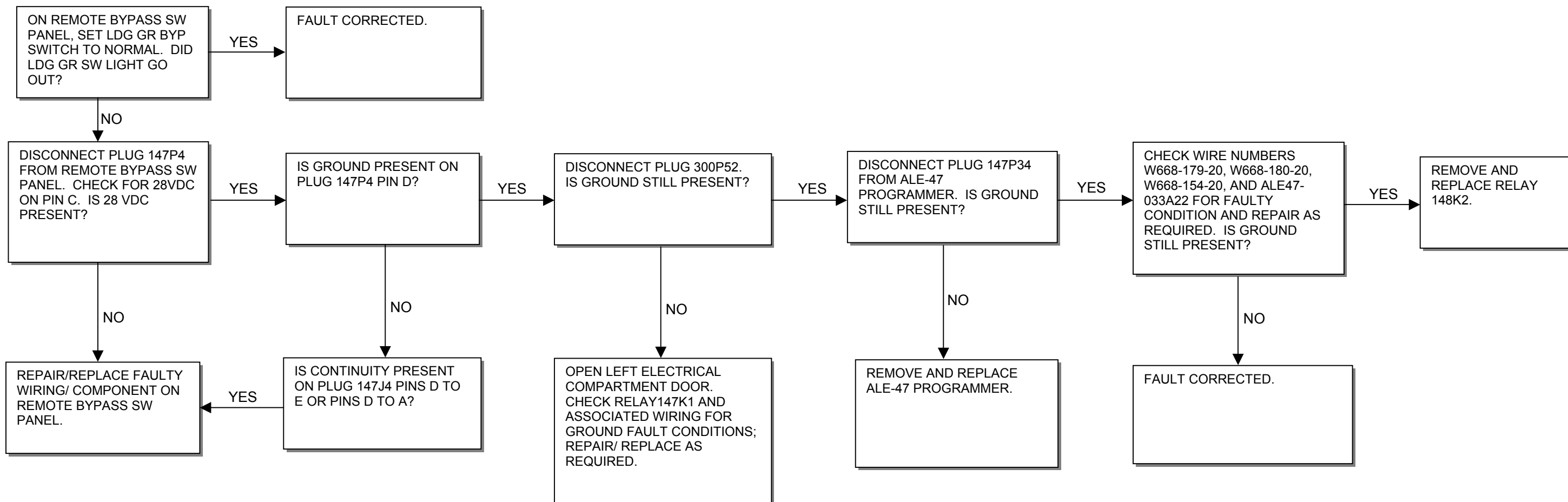

END OF TASK

16-5.6 LANDING GEAR SWITCH STATUS, READY TO FIRE, OR LANDING GEAR BYPASS LIGHTS DO NOT LIGHT DURING PRESS TO TEST

FAULT ISOLATION PROCEDURE

INITIAL SETUP

Personnel Required:
Avionics Mechanic

Applicable Configurations:

All

References:

TM 55-1520-240-23

Tools:

Electronic Equipment Tool Kit,
NSN 5180-00-064-5178

Equipment Conditions:

TM 55-1520-240-23:
Battery Connected
Electrical Power On
Hydraulic Power Off

Materials:

None

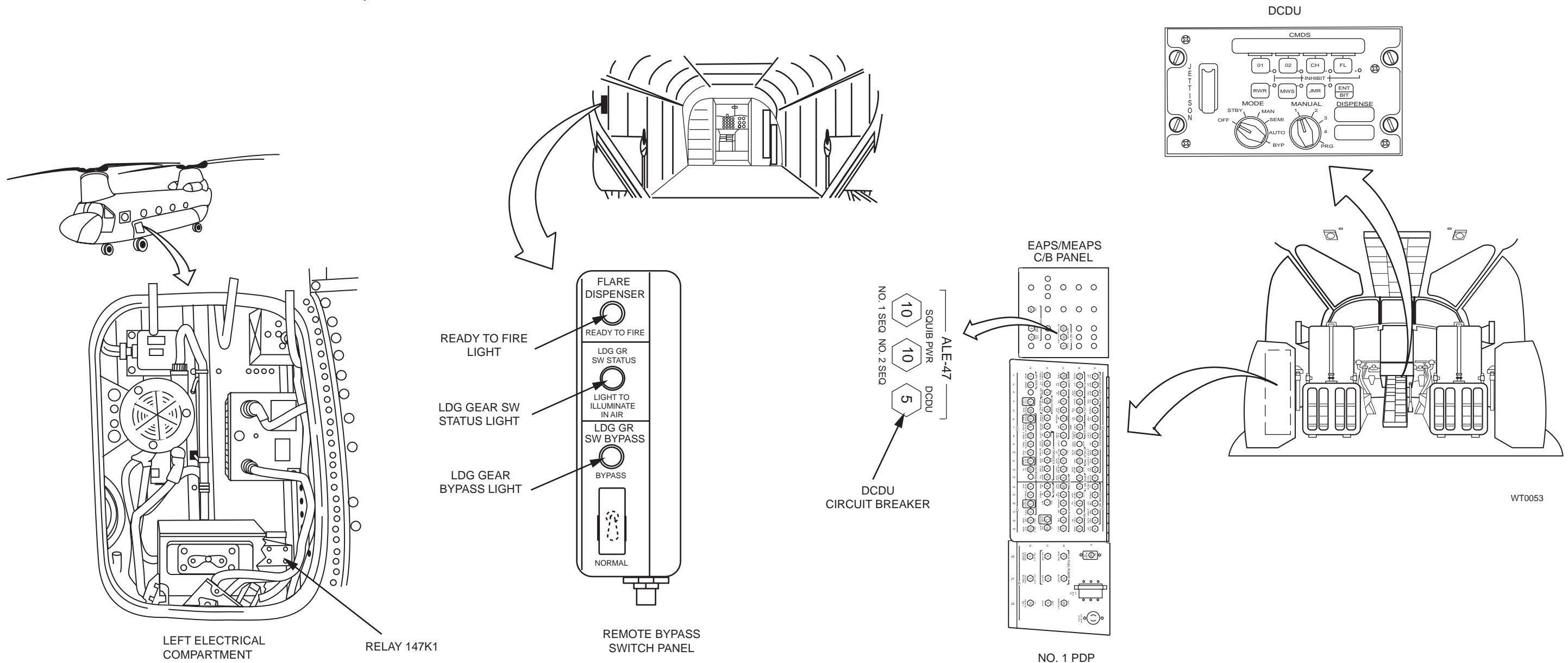

GO TO NEXT PAGE

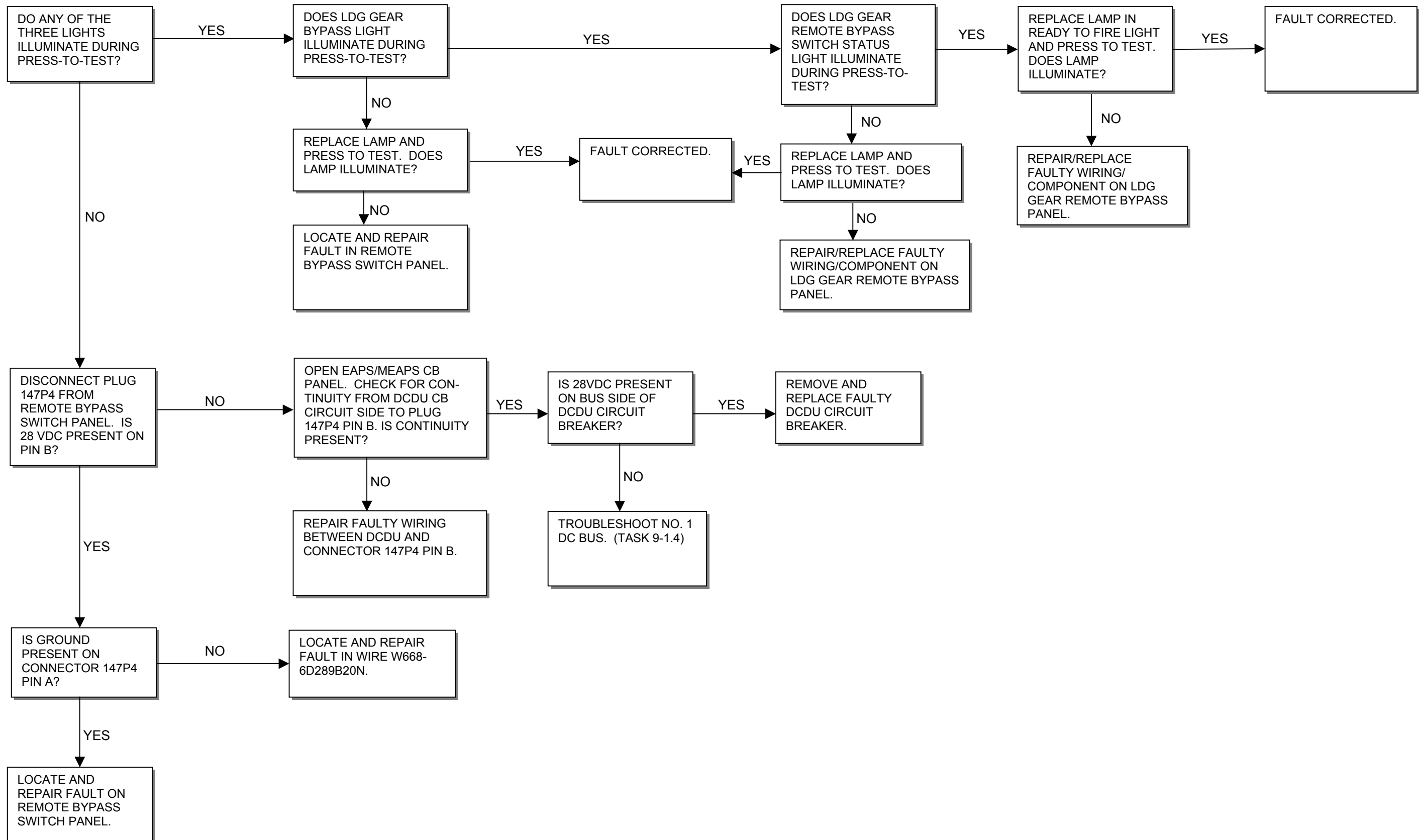

END OF TASK

16-5.7 LANDING GEAR SWITCH STATUS LIGHT DOES NOT COME ON

FAULT ISOLATION PROCEDURE

INITIAL SETUP

Personnel Required:
Avionics Mechanic

Applicable Configurations:
All

References:
TM 55-1520-240-23

Tools:
Electronic Equipment Tool Kit,
NSN 5180-00-064-5178

Equipment Conditions:
TM 55-1520-240-23:
Battery Connected
Electrical Power On
Hydraulic Power Off

Materials:
None

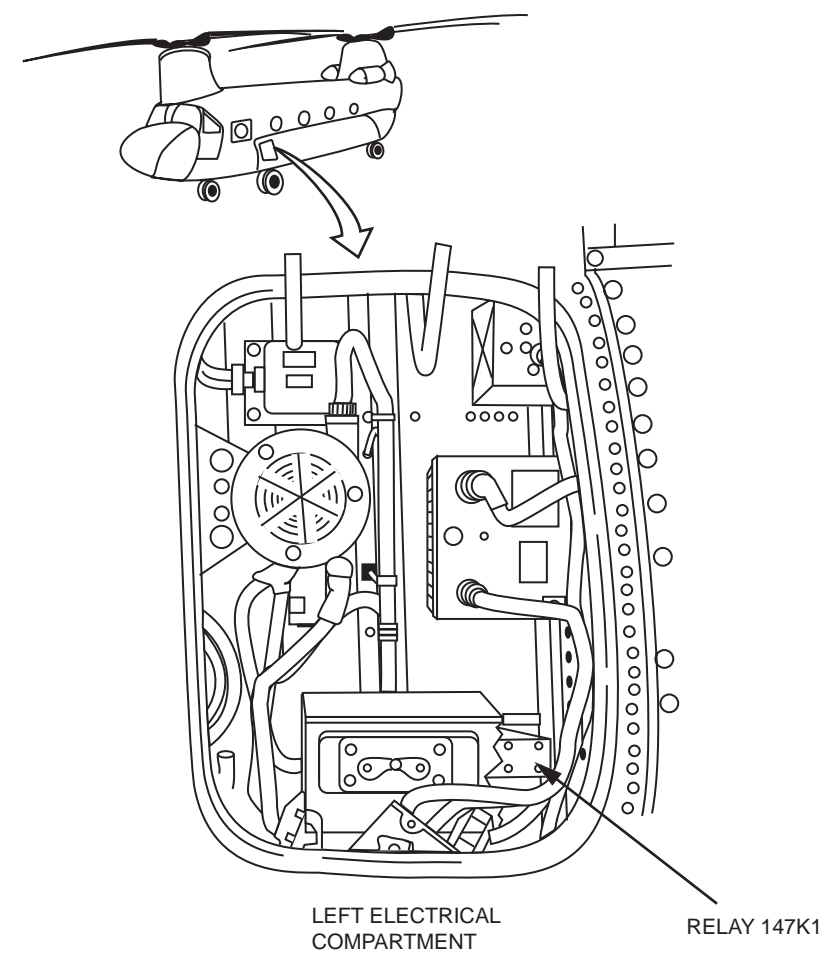
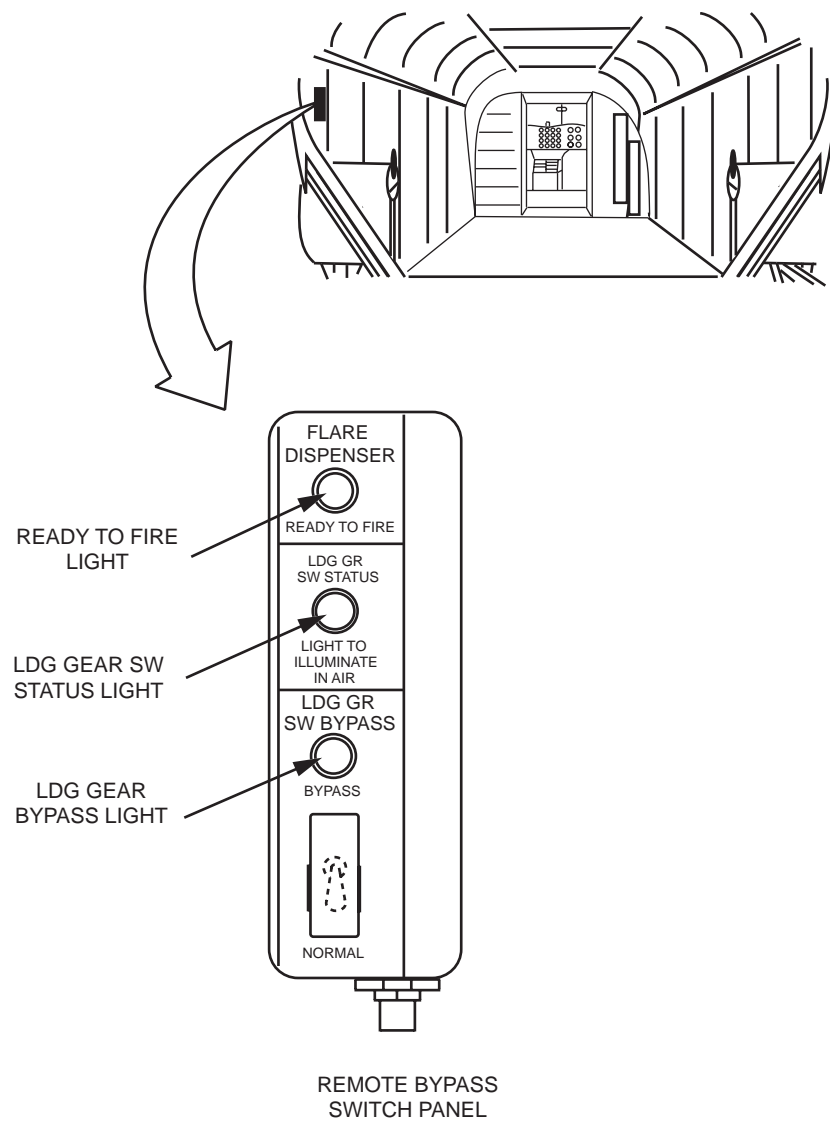

WT0057

GO TO NEXT PAGE

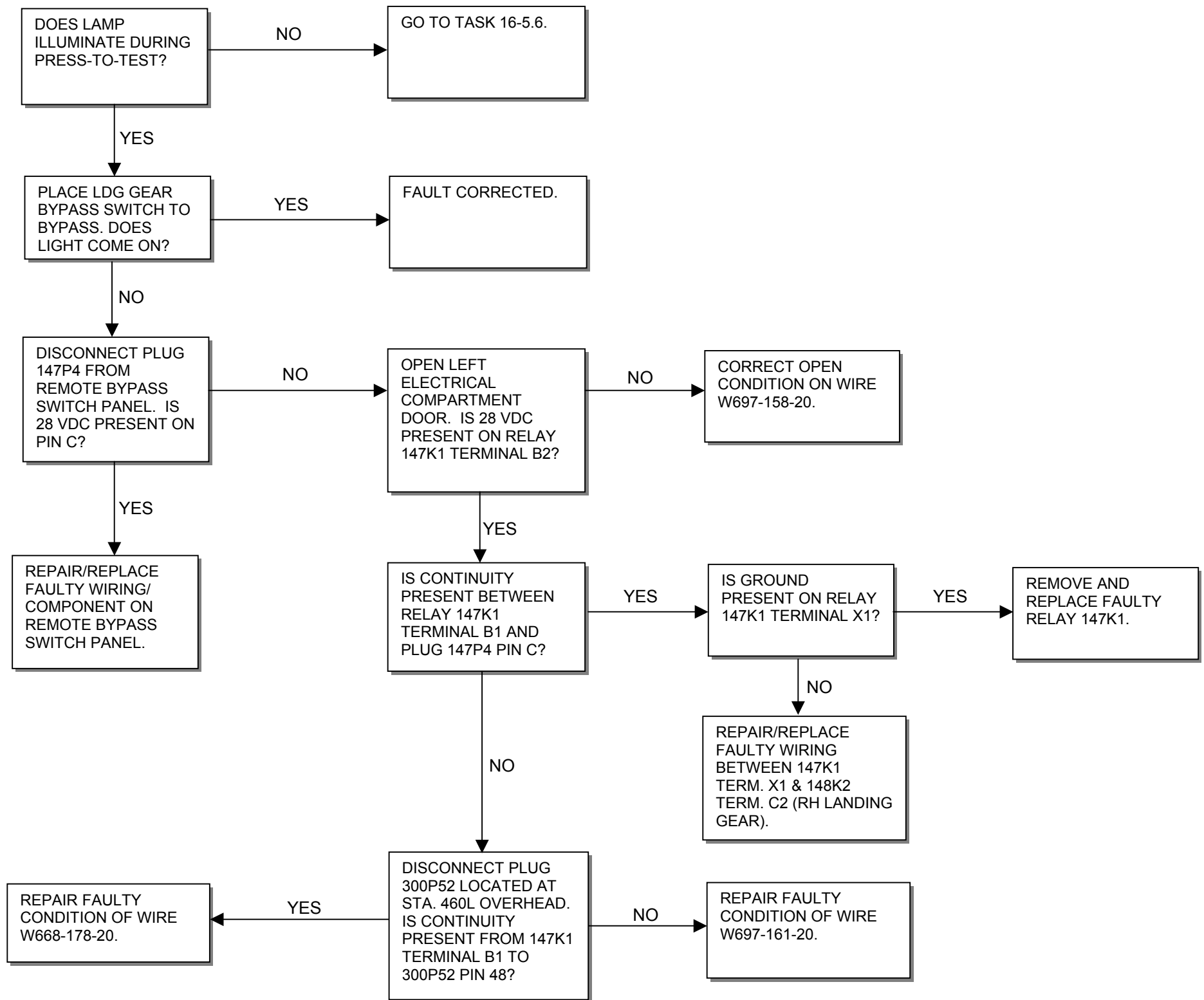

END OF TASK

16-5.8 READY TO FIRE LIGHT DOES NOT COME ON

FAULT ISOLATION PROCEDURE

INITIAL SETUP

Applicable Configurations:

All

Tools:

Electronic Equipment Tool Kit,
NSN 5180-00-064-5178

Materials:

None

Personnel Required:
Avionics Mechanic

References:
TM 55-1520-240-23

Equipment Conditions:
TM 55-1520-240-23:
Battery Connected
Electrical Power On
Hydraulic Power Off

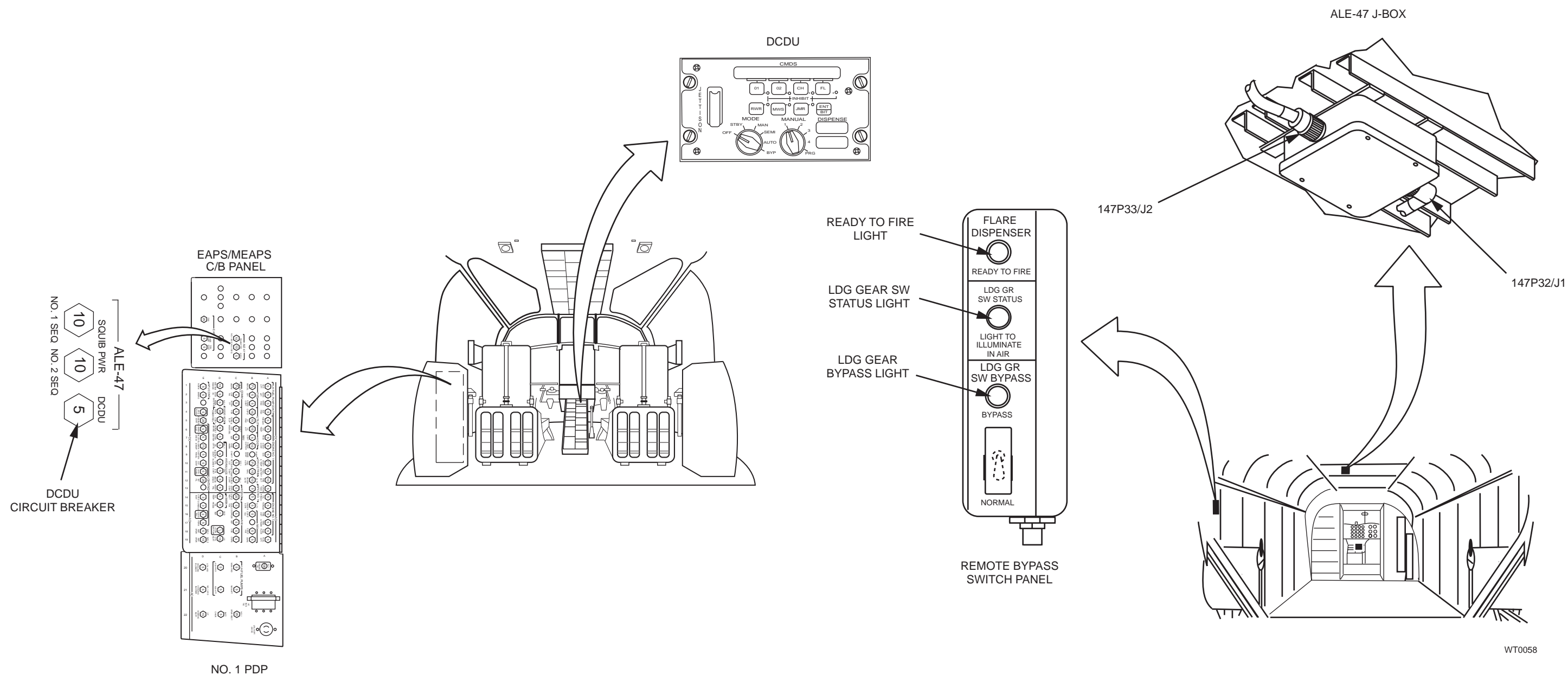

WT0058

GO TO NEXT PAGE

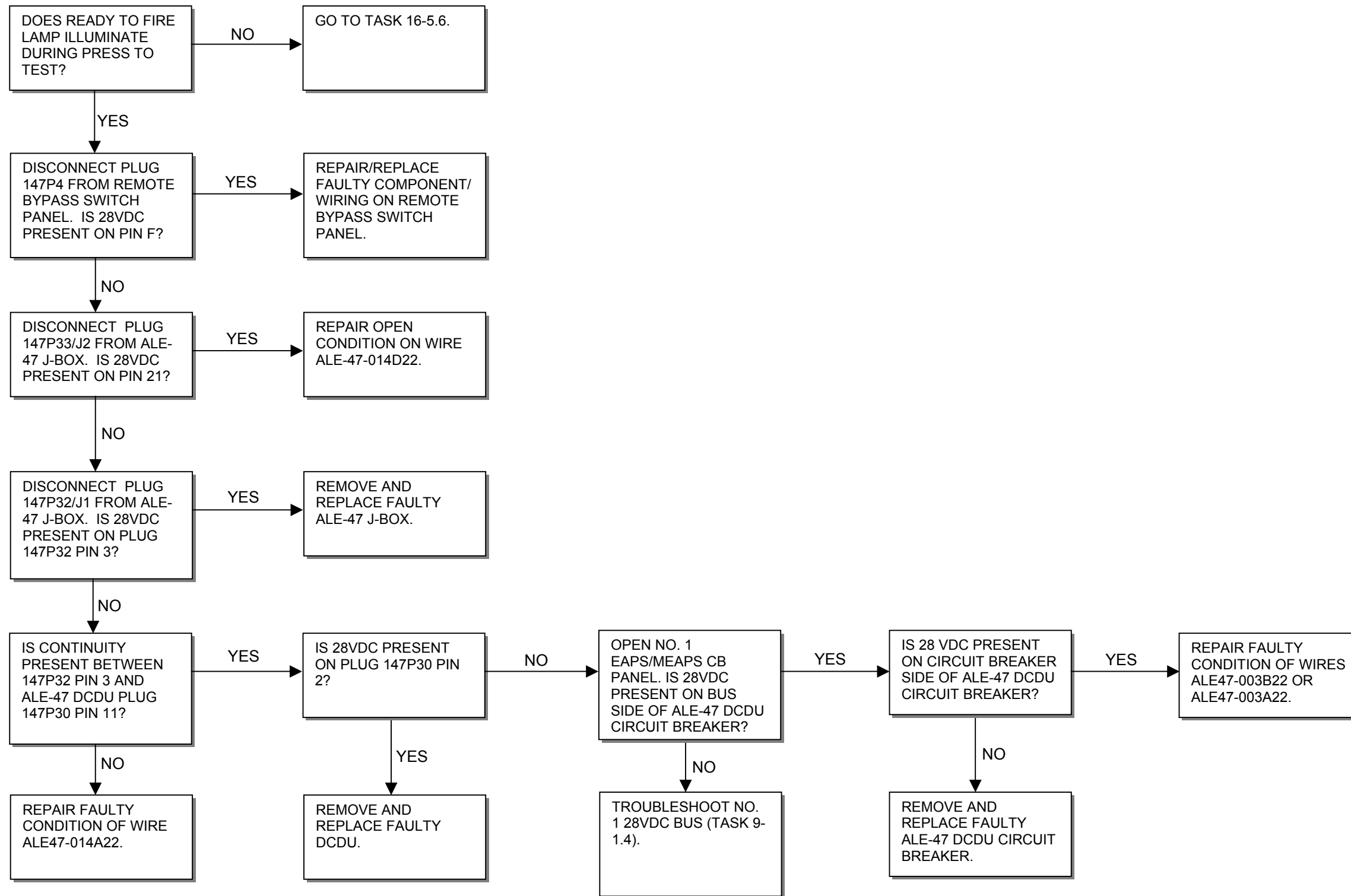

END OF TASK

16-5.9 COUNTERMEASURES DISPENSER TEST SET DOES NOT INDICATE A FIRED EXPENDABLE WHEN COPILOT'S FLARE DISP SWITCH IS PRESSED

FAULT ISOLATION PROCEDURE

INITIAL SETUP

Personnel Required:
Avionics Mechanic

Applicable Configurations:
All

References:
TM 55-1520-240-23

Tools:
Electronic Equipment Tool Kit,
NSN 5180-00-064-5178

Equipment Conditions:
TM 55-1520-240-23:
Battery Connected
Electrical Power On
Hydraulic Power Off

Materials:
None

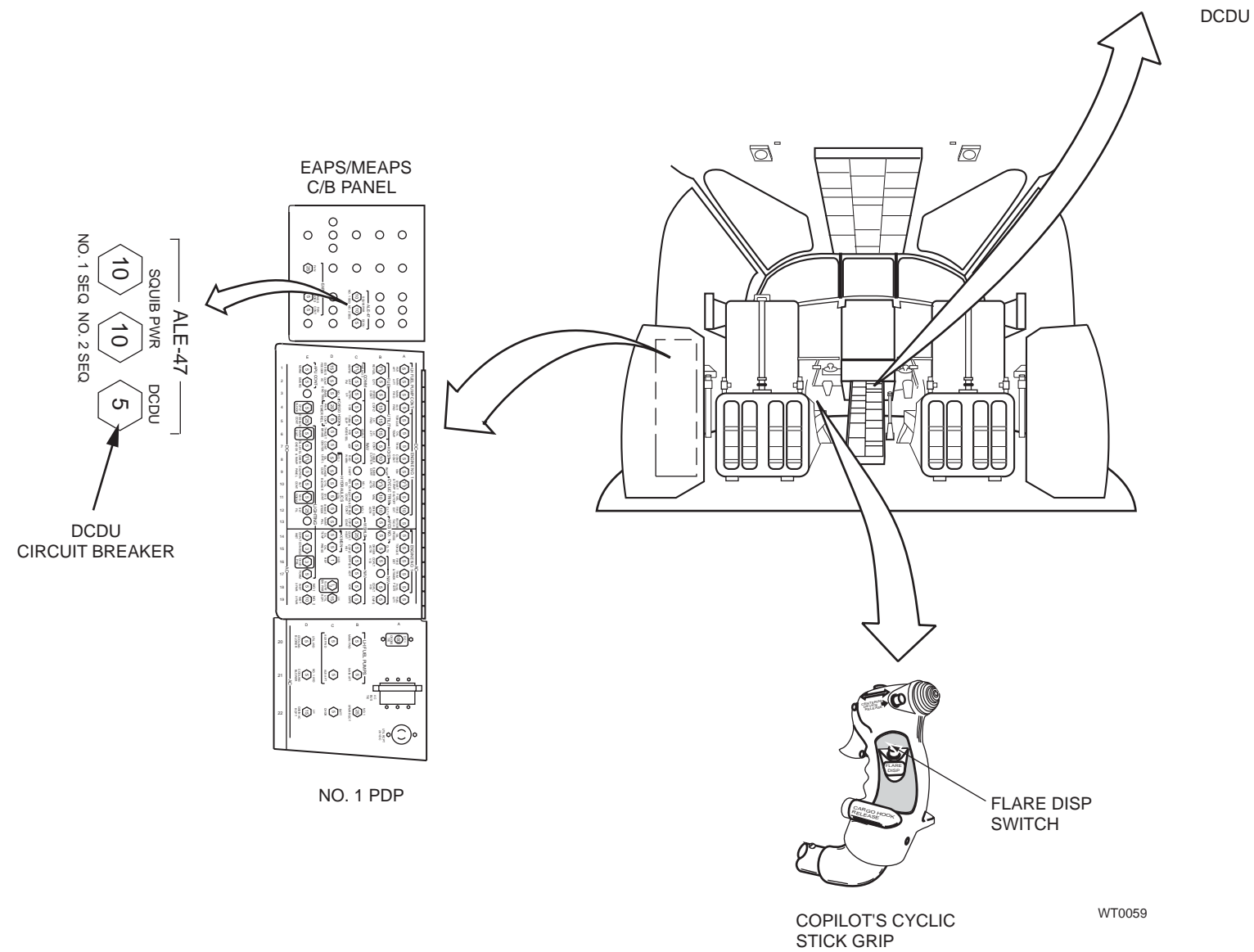
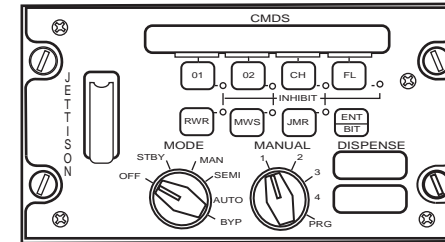

GO TO NEXT PAGE

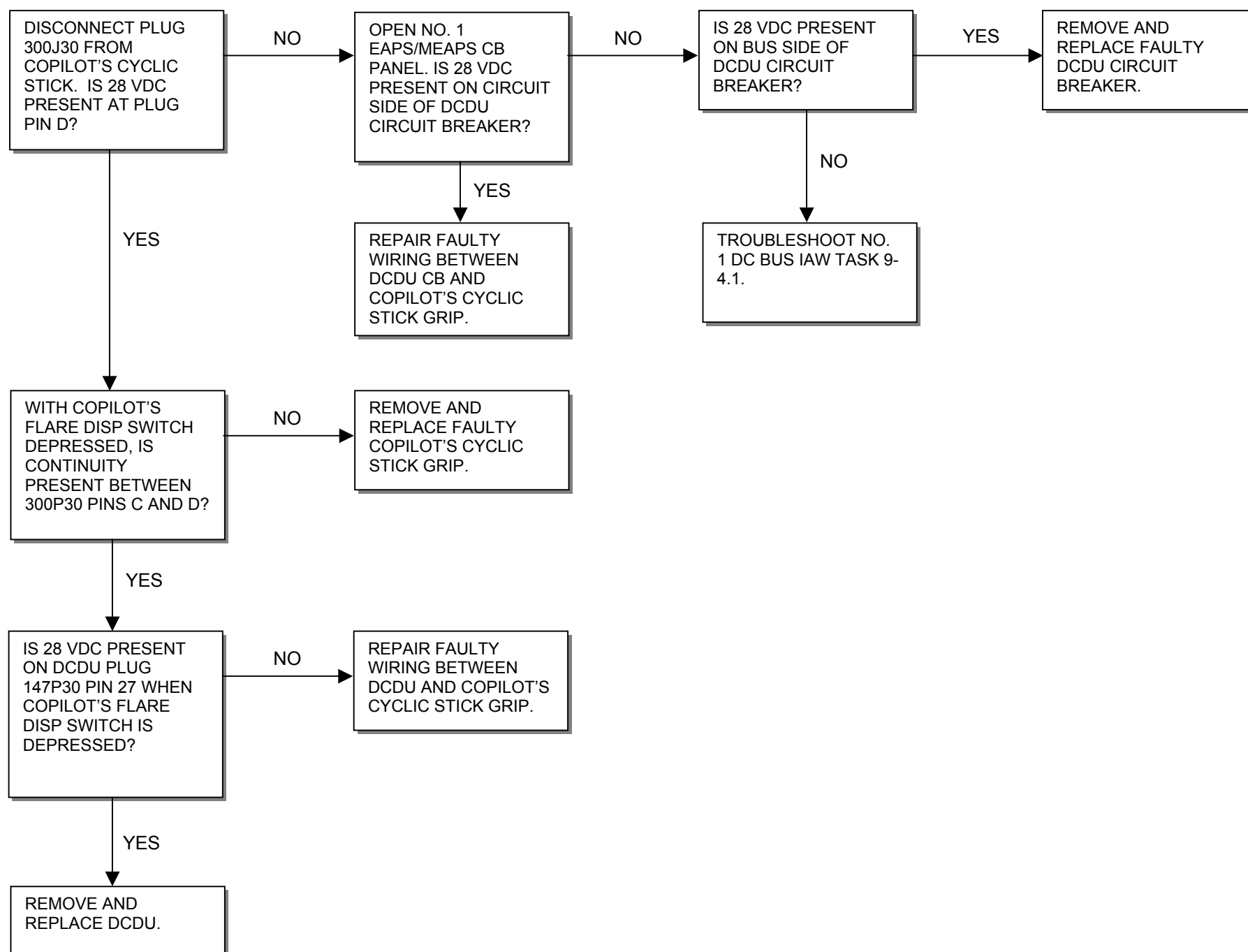

END OF TASK

16-5.10 COUNTERMEASURES DISPENSER TEST SET DOES NOT INDICATE A FIRED EXPENDABLE WHEN PILOT'S FLARE DISP SWITCH IS PRESSED

FAULT ISOLATION PROCEDURE

INITIAL SETUP

Personnel Required:
Avionics Mechanic

Applicable Configurations:
All

References:
TM 55-1520-240-23

Tools:
Electronic Equipment Tool Kit,
NSN 5180-00-064-5178

Equipment Conditions:
TM 55-1520-240-23:
Battery Connected
Electrical Power On
Hydraulic Power Off

Materials:
None

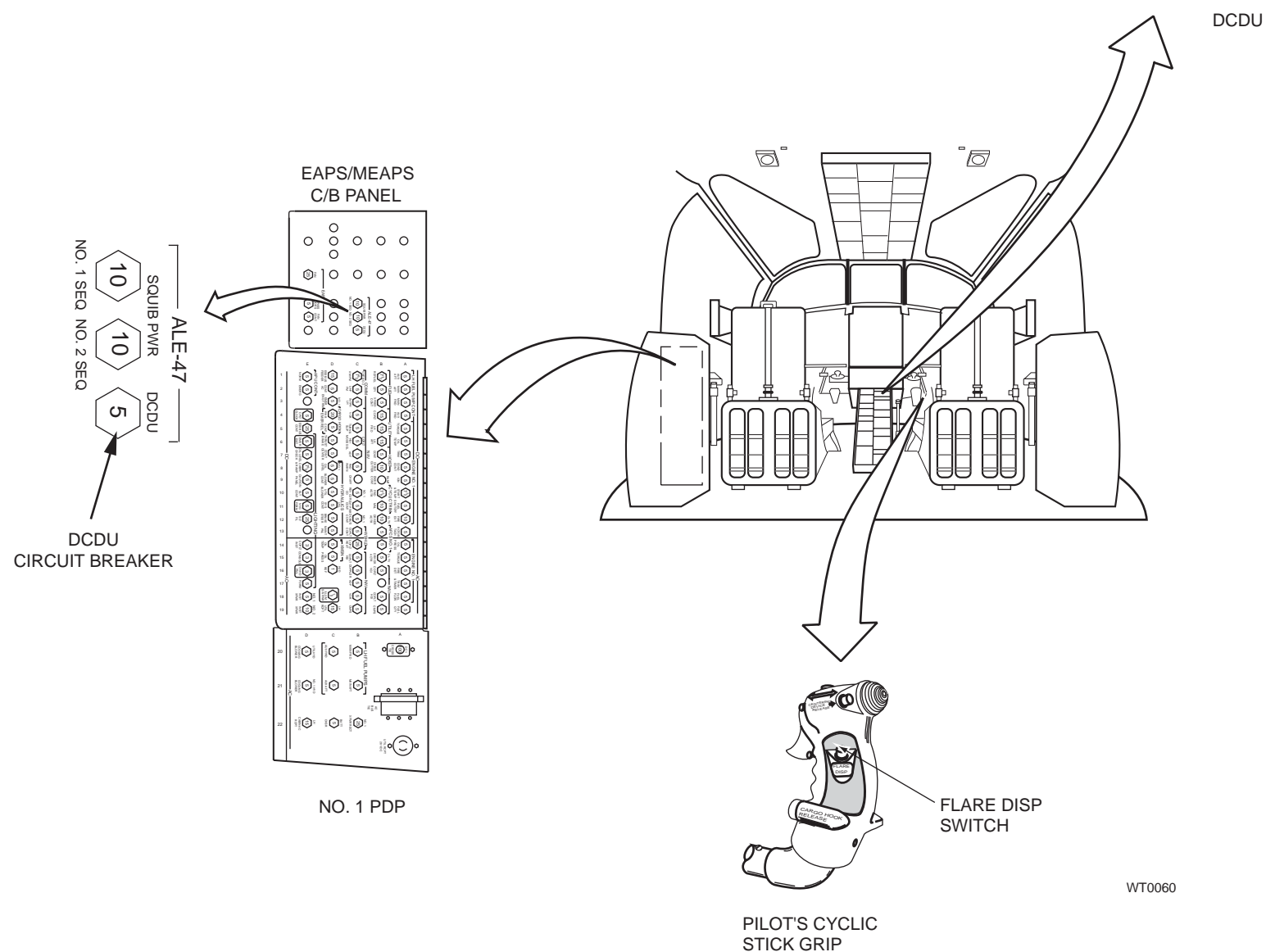
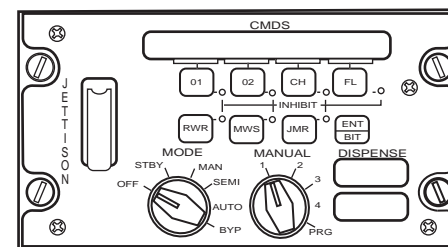

GO TO NEXT PAGE

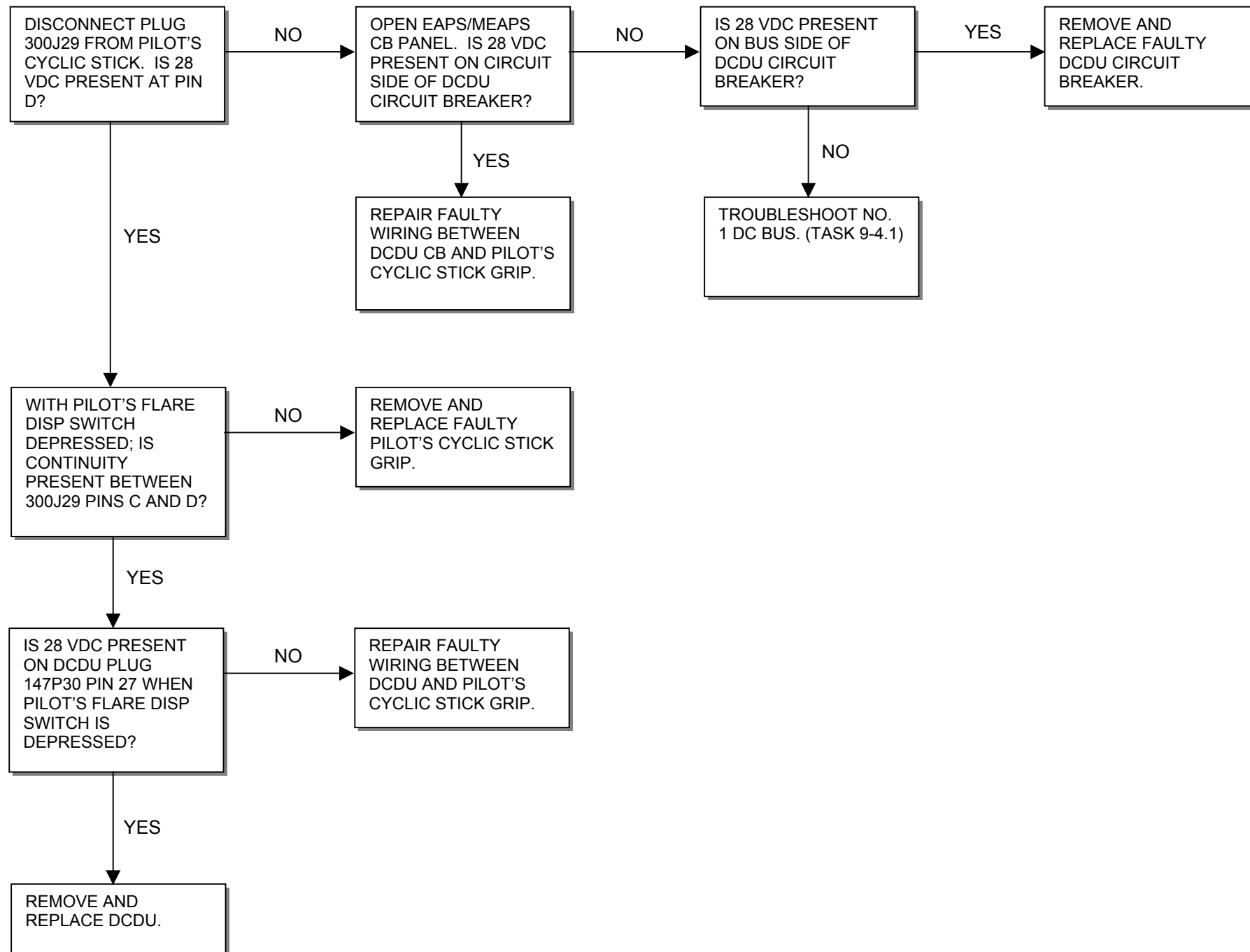

END OF TASK

16-5.11 COUNTERMEASURES DISPENSER TEST SET DOES NOT INDICATE A FIRED EXPENDABLE WHEN ONE CREW DISPENSE SWITCH IS PRESSED

FAULT ISOLATION PROCEDURE

INITIAL SETUP

Personnel Required:
Avionics Mechanic

Applicable Configurations:
All

References:
TM 55-1520-240-23

Tools:
Electronic Equipment Tool Kit,
NSN 5180-00-064-5178

Equipment Conditions:
TM 55-1520-240-23:
Battery Connected
Electrical Power On
Hydraulic Power Off

Materials:
None

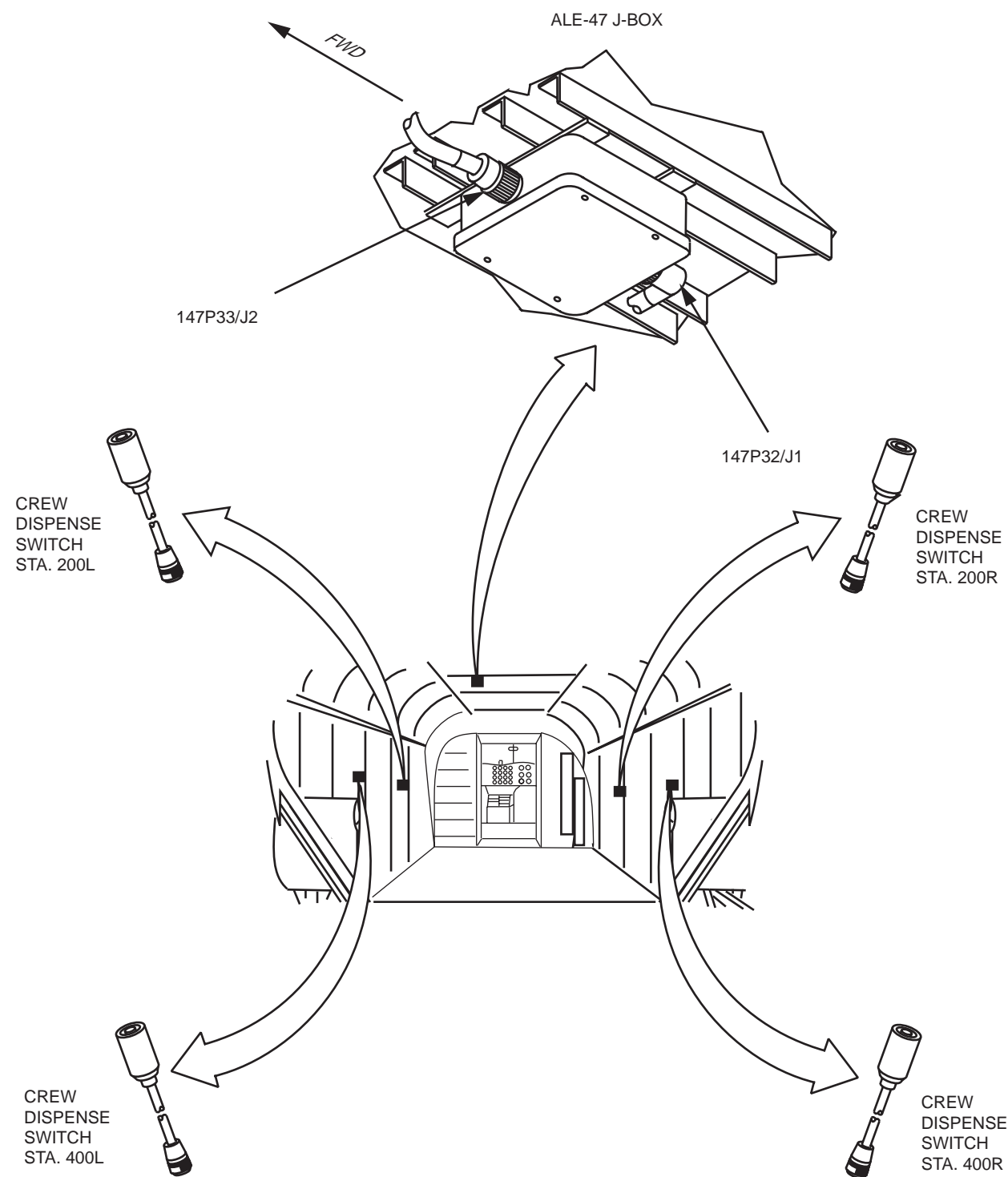

WT0061

GO TO NEXT PAGE

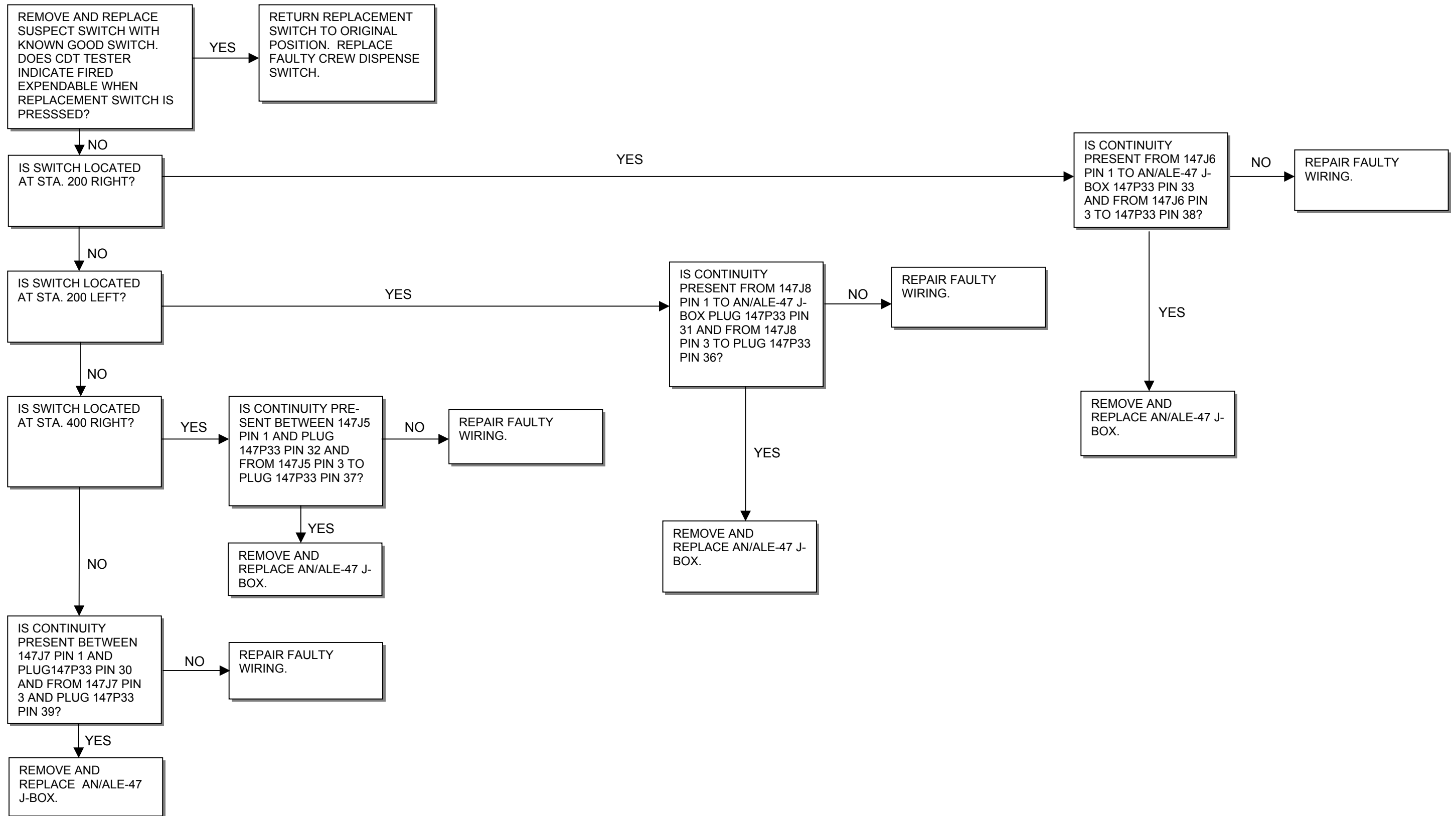

END OF TASK

16-5.12 DCDU DISPLAYS INCORRECT QUANTITY OF EXPENDABLES

FAULT ISOLATION PROCEDURE

INITIAL SETUP

Personnel Required:
Avionics Mechanic

Applicable Configurations:
All

References:
TM 55-1520-240-23

Tools:
Electronic Equipment Tool Kit,
NSN 5180-00-064-5178

Equipment Conditions:
TM 55-1520-240-23:
Battery Connected
Electrical Power On
Hydraulic Power Off
AN/ALE-47 Safety Switch Pin Installed

Materials:
None

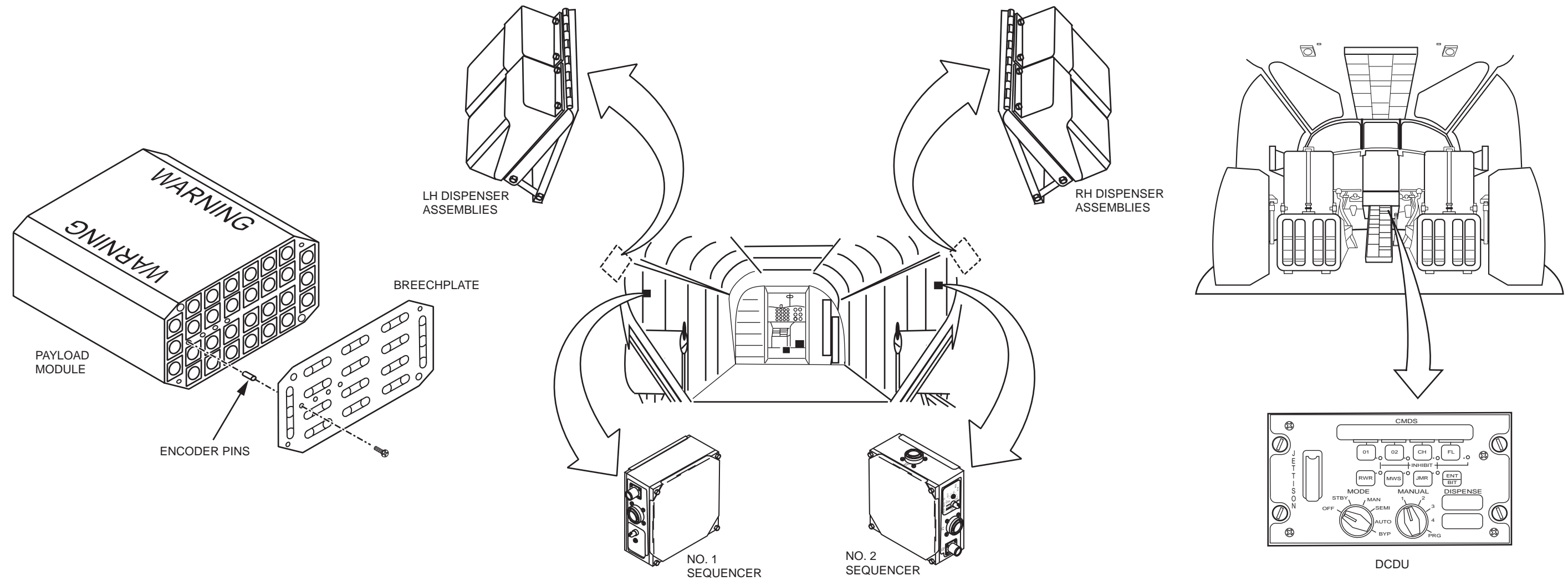

WT0064

GO TO NEXT PAGE

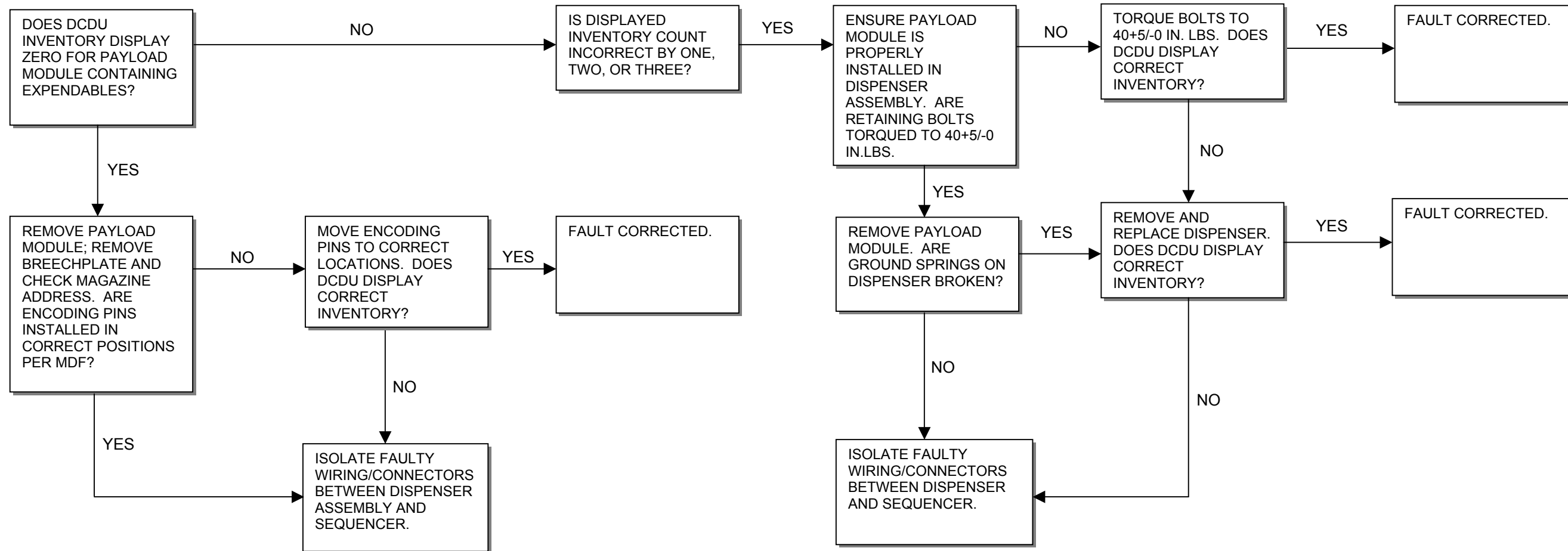

END OF TASK

16-5.13 LANDING GEAR BYPASS SWITCH LIGHT DOES NOT COME ON

16-5.13

FAULT ISOLATION PROCEDURE

INITIAL SETUP

Personnel Required:
Avionics Mechanic

Applicable Configurations:
All

References:
TM 55-1520-240-23

Tools:
Electronic Equipment Tool Kit,
NSN 5180-00-064-5178

Equipment Conditions:
TM 55-1520-240-23:
Battery Connected
Electrical Power On
Hydraulic Power Off

Materials:
None

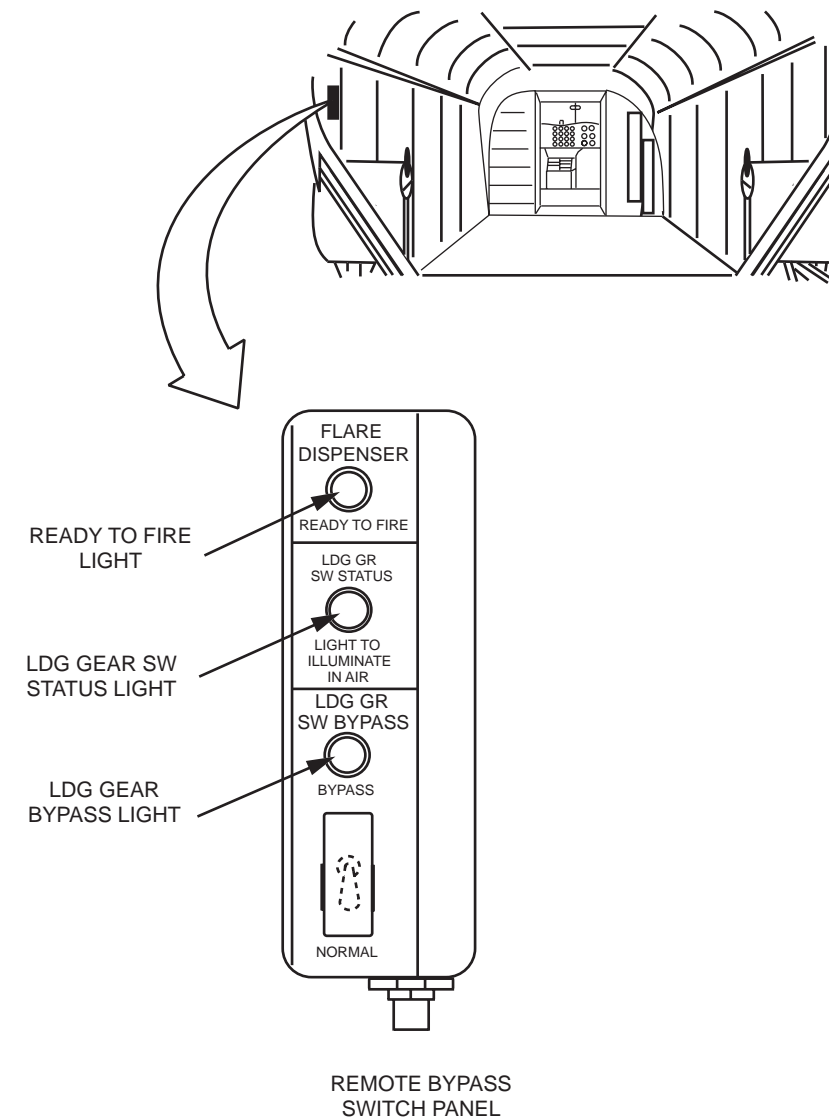
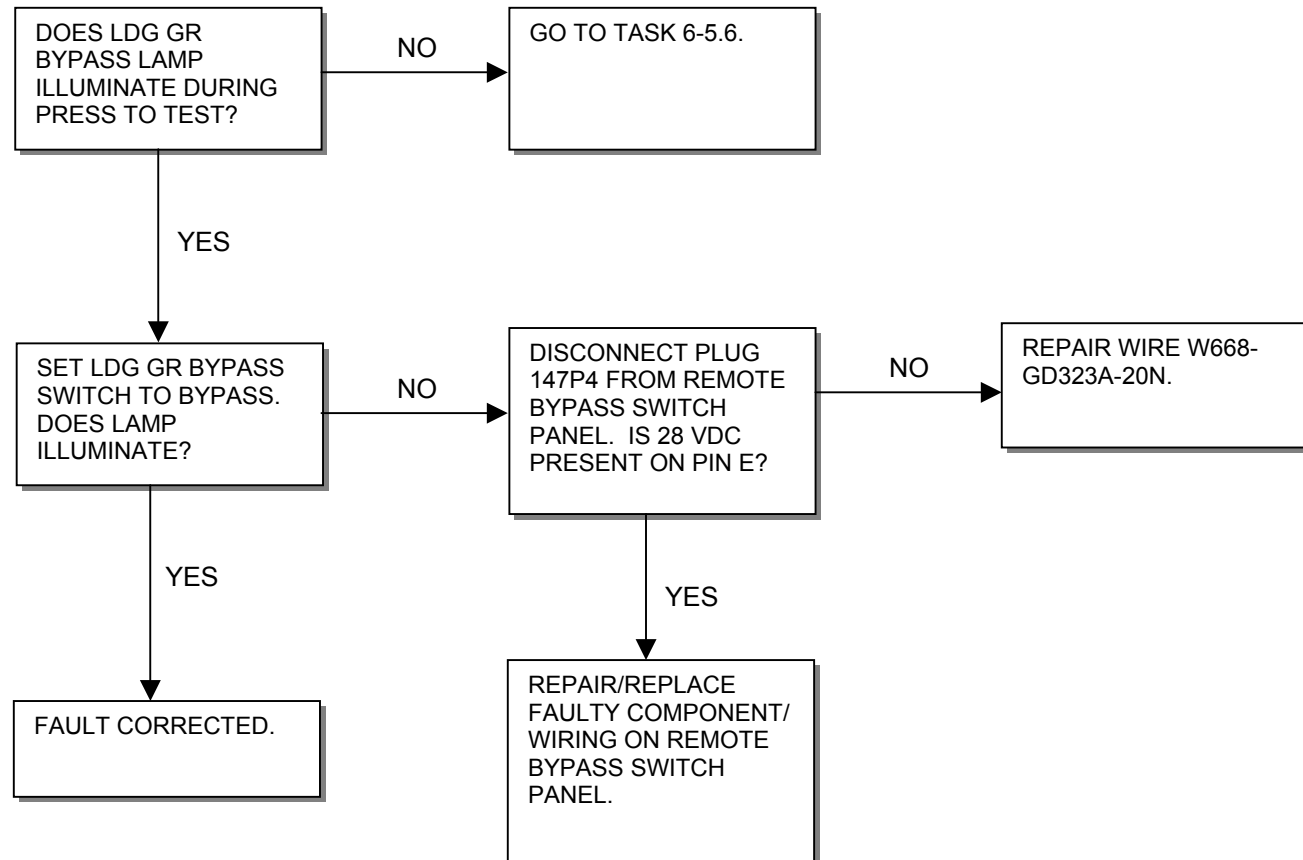

WT0054

END OF TASK

CHAPTER 17
EMERGENCY EQUIPMENT TROUBLESHOOTING

**CHAPTER 17
EMERGENCY EQUIPMENT TROUBLESHOOTING
CHAPTER OVERVIEW**

Chapter 17 contains procedures for Emergency Equipment troubleshooting. Emergency equipment system failure symptom is listed below, Included in this Chapter are locations and views of all electrical connectors, receptacles, relays, and ground connections for Emergency Equipment system.

Refer to TM 55-1520-240-23 for required Emergency Equipment system maintenance procedures.

SYSTEM	PARA
EMERGENCY EXIT LIGHTS	17-1

**FAILURE SYMPTOM LIST
EMERGENCY EXIT LIGHTS**

SYMPTOM	TASK
CHARGE INDICATOR LAMPS ON ONE OR MORE EMERGENCY EXIT LIGHTS DO NOT COME ON WHEN SWITCH IS SET TO ARM	17-1.3
CHARGE INDICATOR LAMPS ON ONE OR MORE EMERGENCY EXIT LIGHTS DO NOT COME ON WHEN SWITCH IS AT DISARM	17-1.3
EMERGENCY EXIT LIGHT MAIN LAMPS COME ON WHEN SWITCH IS AT ARM	17-1.3

SYMPTOM	TASK
EMERGENCY EXIT LIGHT MAIN LAMPS DO NOT COME ON WHEN SWITCH IS AT TEST	17-1.3

SYMPTOM	TASK
ONE OR MORE EMERGENCY EXIT LIGHTS WILL NOT GO OUT WHEN SWITCH IS SET TO DISARM	17-1.3

GO TO NEXT PAGE

EMERGENCY SYSTEM ELECTRICAL COMPONENT LOCATION AND CONFIGURATION LIST

REF DESIG	PART NUMBER	TYPE	MATE WITH/LOCATION	STATION LOCATION		
				FS	WL	BL
GD 119		151	AFT CROWN - RAMP	594	50	24L
GD 120		151	AFT CROWN	482	50	15R
GD 168		151	LH CABIN - ESCAPE HATCH	150	30	50L
GD 169		151	RH CABIN - CABIN DOOR	175	50	50R
129P1	MS3476W10-6S	15	INERTIA SWITCH	482	50	15R
300J1	M83723-74A2041N	40	NO. 1 PDP			
300P1	M83723-75A2041N	40	NO. 1 PDP			
300J19	M83723-73A2041N	40	OVERHEAD PANEL - COCKPIT			
300P19	M83723-76A2041N	40	OVERHEAD PANEL - COCKPIT			
300J20	M83723-74A2461N	43	OVERHEAD PANEL - COCKPIT			
300P20	M83723-75A2461N	43	OVERHEAD PANEL - COCKPIT			
300J45	M83723-73A2461N	43	HEATER COMPARTMENT - OVHD	105	40	30R
300P45	M83723-76A2461N	43	HEATER COMPARTMENT - OVHD	105	40	30R
300J47	M83723-74A2461N	43	HEATER COMPARTMENT - OVHD	105	40	30R
300P47	M83723-75A2461N	43	HEATER COMPARTMENT - OVHD	105	40	30R
300J51	M83723-74A2461N	43	AFT CROWN	460	45	20R
300P51	M83723-75A2461N	43	AFT CROWN	460	45	20R

EMERGENCY EQUIPMENT ELECTRICAL COMPONENT
LOCATION AND CONFIGURATION LIST (Continued)

RECEPTACLE

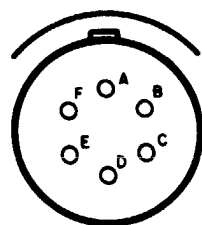

15

PLUG

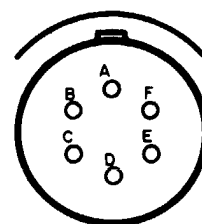

15

GND STUD



151

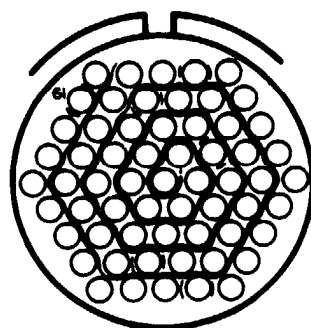

43

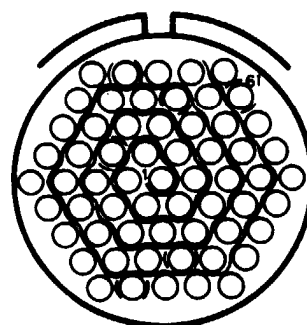

43

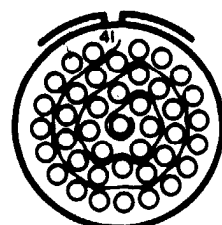

40

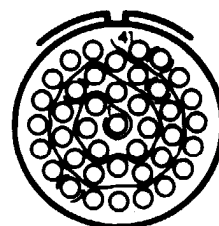

40

17-1 EMERGENCY EXIT LIGHTS

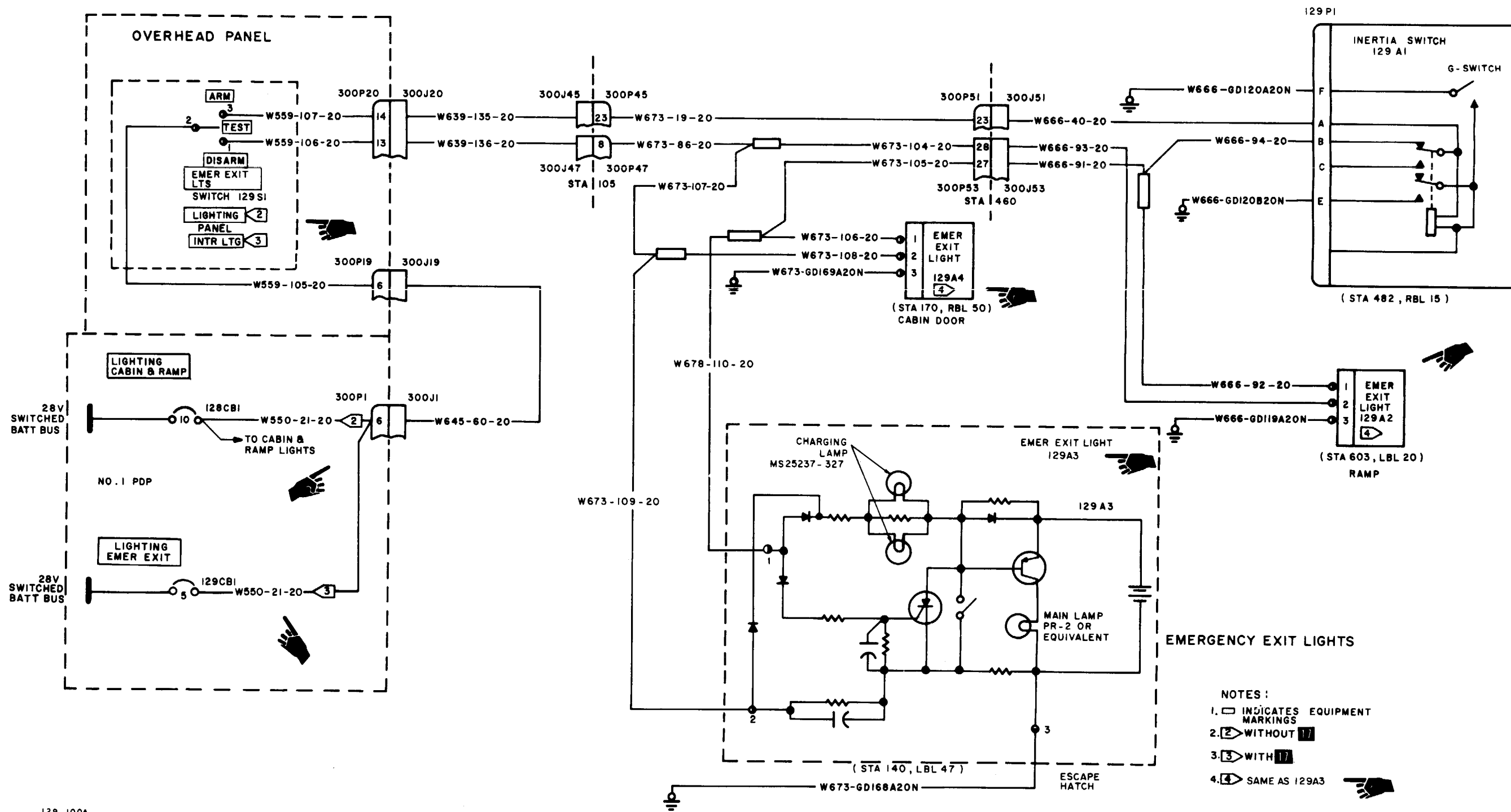

- NOTES:
1. [] INDICATES EQUIPMENT MARKINGS
 2. [2] WITHOUT [17]
 3. [3] WITH [17]
 4. [4] SAME AS I29A3

129.100A

17-1.2 EMERGENCY EXIT LIGHTS VISUAL CHECK

INITIAL SETUP

Applicable Configurations:

All

Tools:

Electrical Repairer's Tool Kit,
NSN 5180-00-323-4915

Materials:

None

Personnel Required:

Aircraft Electrician

References:

TM 55-1520-240-23

Equipment Condition:

TM 55-1520-240-23:

Battery Disconnected

Electrical Power Off

Hydraulic Power Off

TASK	RESULT
1. Check EMER EXIT LTS or EMER EXIT switch (1).	If switch (1) is loose or damaged, tighten or replace it as required.
2. Check escape hatch emergency exit light (2).	If emergency exit light (2) is loose or damaged, tighten or replace it as required.
3. Check cabin door emergency exit light (3).	If emergency exit light (3) is loose or damaged, tighten or replace it as required.
4. Check inertia switch (4) at sta 482, bl 15R.	If inertia switch (4) is loose or damaged, repair or replace it. If connector is loose or damaged, tighten or replace it. If wires to connector are broken or damaged, repair or replace wires as required.
5. Check ramp emergency exit light (5).	If emergency exit light (5) is loose or damaged, tighten or replace it as required.
6. Check emergency exit lights (2, 3, 4, and 5) PULL handles.	If PULL handles are not recessed into body of exit lights (2, 3, 4, and 5) remove and reinstall lights pushing PULL handles against light assembly.

FOLLOW-ON MAINTENANCE:

None

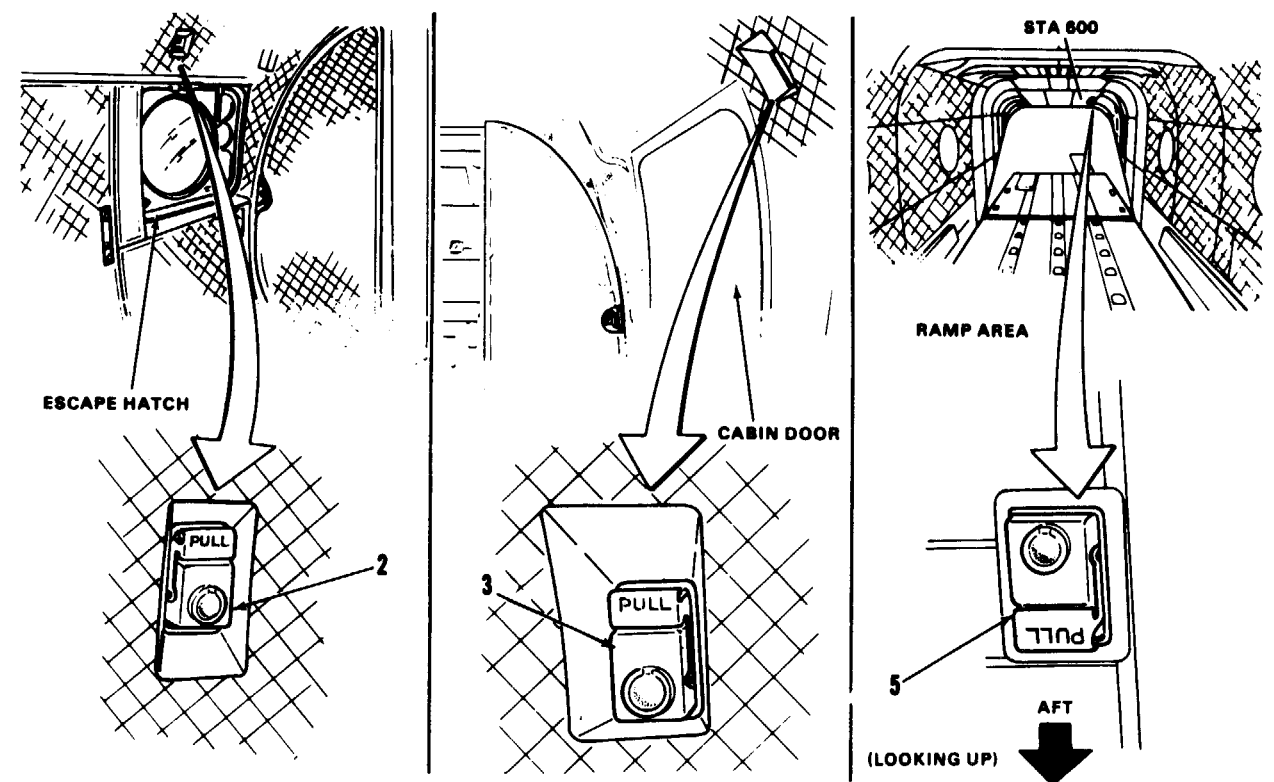
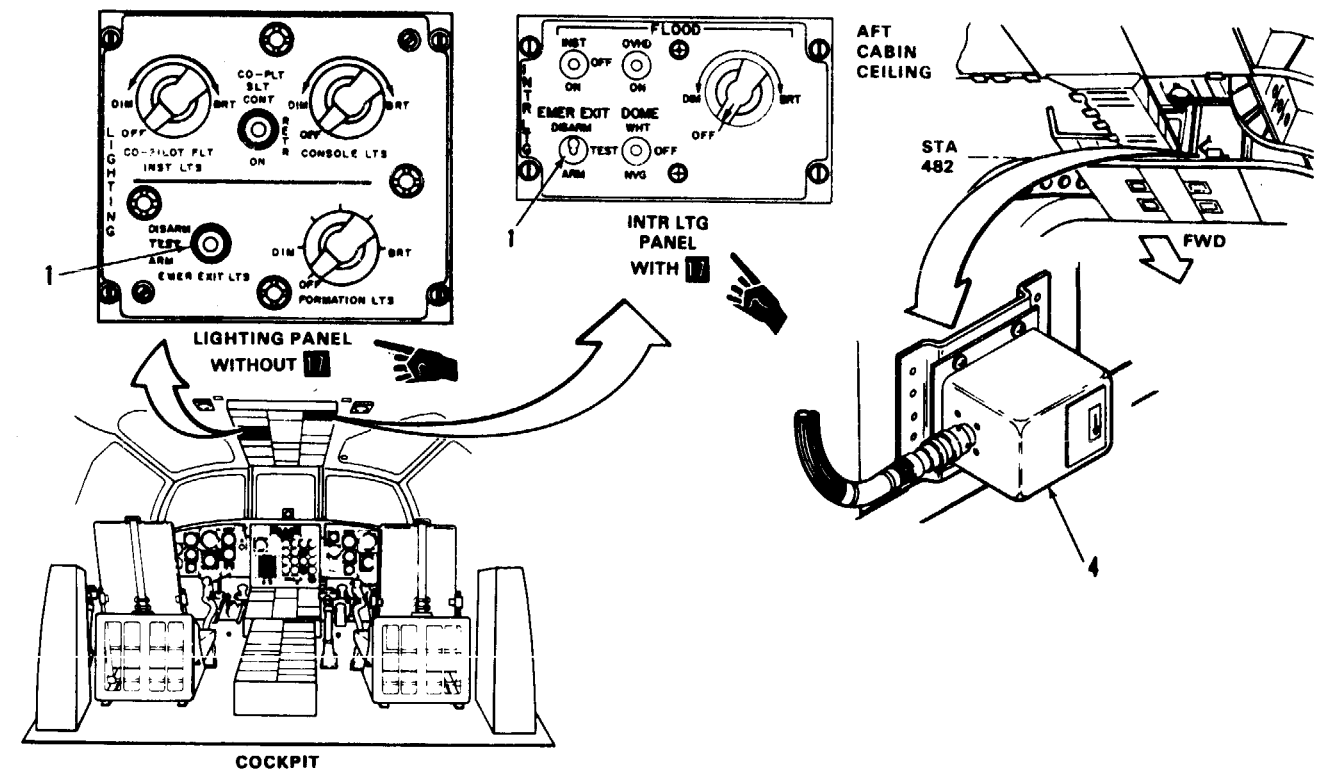

10211

INITIAL SETUP

Applicable Configurations:

All

Tools:

None

Materials:

None

Personnel Required:

Aircraft Electrician

References:

TM 55-1520-240-23

Equipment Condition:

TM 55-1520-240-23:

Electrical Power Off

Battery Disconnected

Hydraulic Power Off

Visual Check of Emergency Exit Lights Performed

(Task 17-1.2)

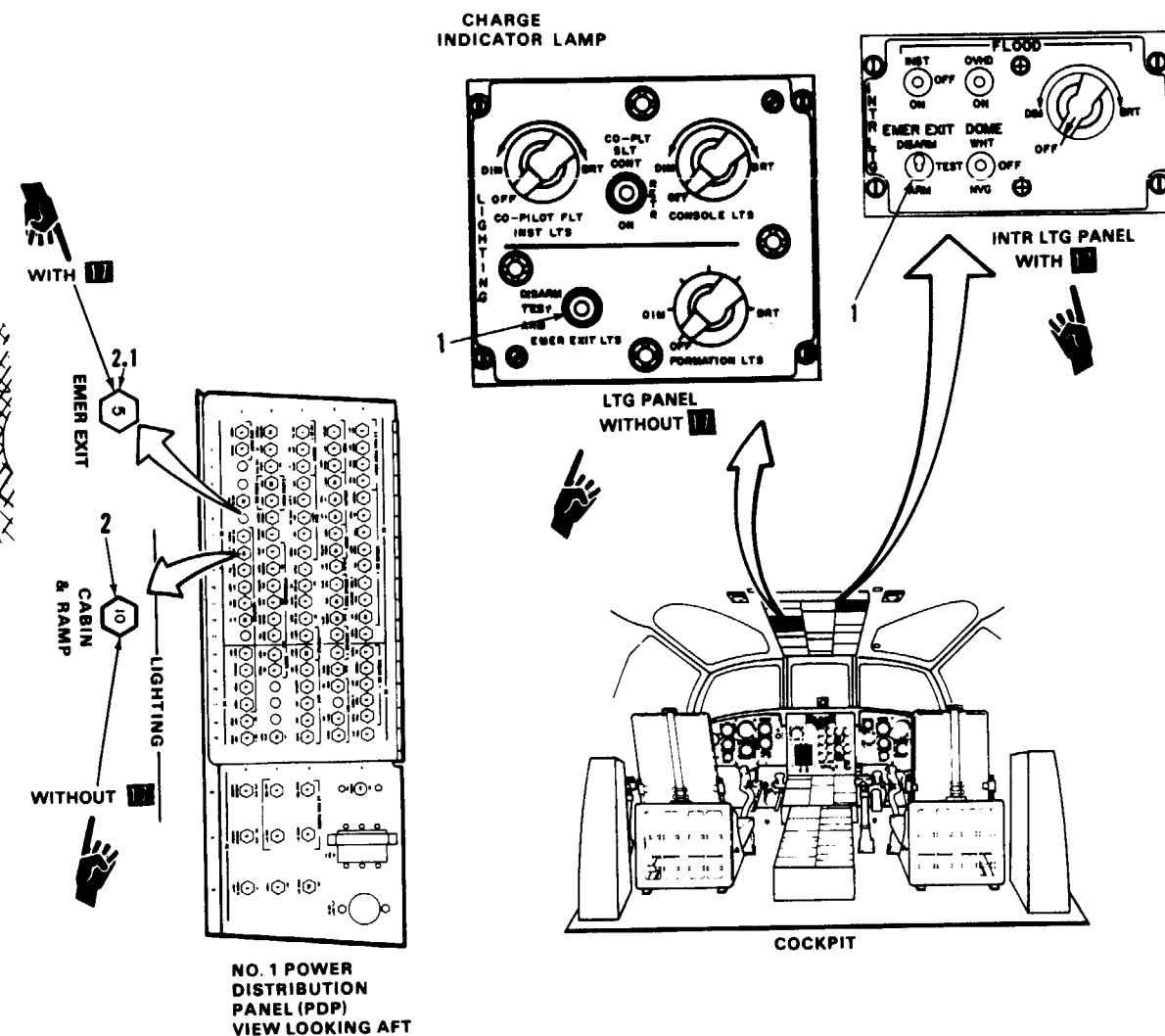
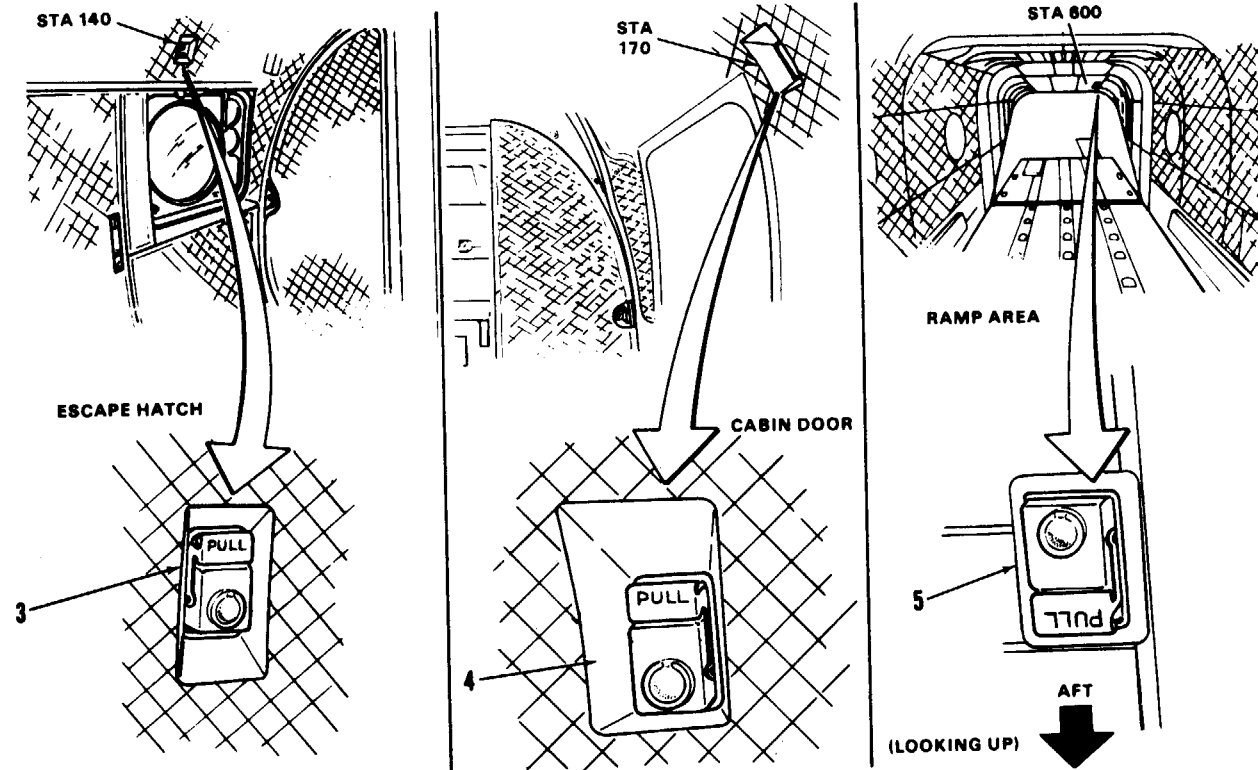
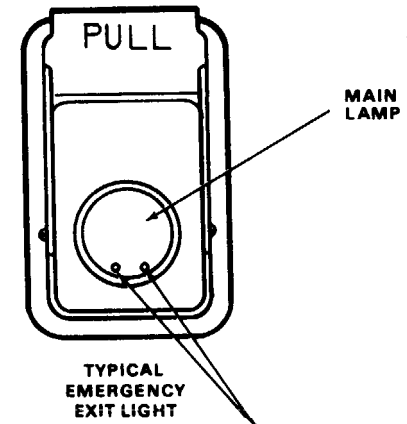

TASK	RESULT
1. Set EMER EXIT LTS or EMER EXIT switch (1) to DISARM.	
2. Connect battery. Refer to TM 55-1520-240-23.	
3. Without 17 check CABIN & RAMP lighting circuit breaker (2).	If breaker (2) is open, close it. If it opens again, go to task 9-15.4.
4. With 17 check EMER EXIT lighting circuit breaker (2. 1).	If breaker (2.1) is open, close it. If it opens again, go to task 17-1.8.
5. Check emergency exit lights (3, 4, and 5).	Main lamps on emergency exit lights (3, 4, and 5) shall be out. If not go to task 17-1.4. Charge indicator lamps on emergency exit lights (3, 4, and 5) shall be on. If not, go to task 17-1.8.
6. Set EMER EXIT LTS or EMER EXIT switch (1) to ARM.	Charge indicator lamps shall come on and main lamps shall be off at each emergency exit light (3, 4, and 5). If charge indicator lamps are not on, go to task 17-1.5. If main lamps are on, go to task 17-1.6.
7. Set EMER EXIT LTS or EMER EXIT switch (1) to TEST.	Main lamps shall come on and charge indicator lamps shall be off at each emergency exit light (3, 4, 5). If main lamps do not come on, go to task 17-1.7. If charge indicator lamps do not go out, replace EMER EXIT LTS or EMER EXIT switch.
8. Set EMER EXIT LTS or EMER EXIT switch (1) to ARM.	Main lamps on emergency exit lights (3, 4, and 5) shall go out. If not, go to task 17-1.4. Charge indicator lamps on emergency exit lights (3, 4, and 5) shall be on. If not go to task 17-1.5.

NOTE

Leave EMER EXIT LTS switch at ARM for 10 minutes before doing next step.

CAUTION

EMER EXIT LTS or EMER EXIT switch must be at DISARM when electrical power is removed. If switch is in ARM and battery switch is turned off, exit lights will come on and discharge internal batteries.

TASK	RESULT
9. Set EMER EXIT LTS or EMER EXIT switch (1) to DISARM.	Main lamps on emergency exit lights (3, 4, and 5) shall go out If not, go to task 17-1.4. Charge indicator lamps on emergency exit lights (3, 4, and 5) shall be on. If not, go to task 17-1.8.

FOLLOW-ON MAINTENANCE:

TM 55-1520-240-23:
Battery Disconnected

FAULT ISOLATION PROCEDURE

INITIAL SETUP

Applicable Configurations:

All

Tools:

Electrical Repairer's Tool Kit,

NSN 5180-00-323-4915

Multimeter

Materials:

None

Personnel Rquired:
Aircraft Electrician

References:

TM 55-1520-240-23

Equipment Condition:

TM 55-1520-240-23:

Electrical Power On
Battery Connected

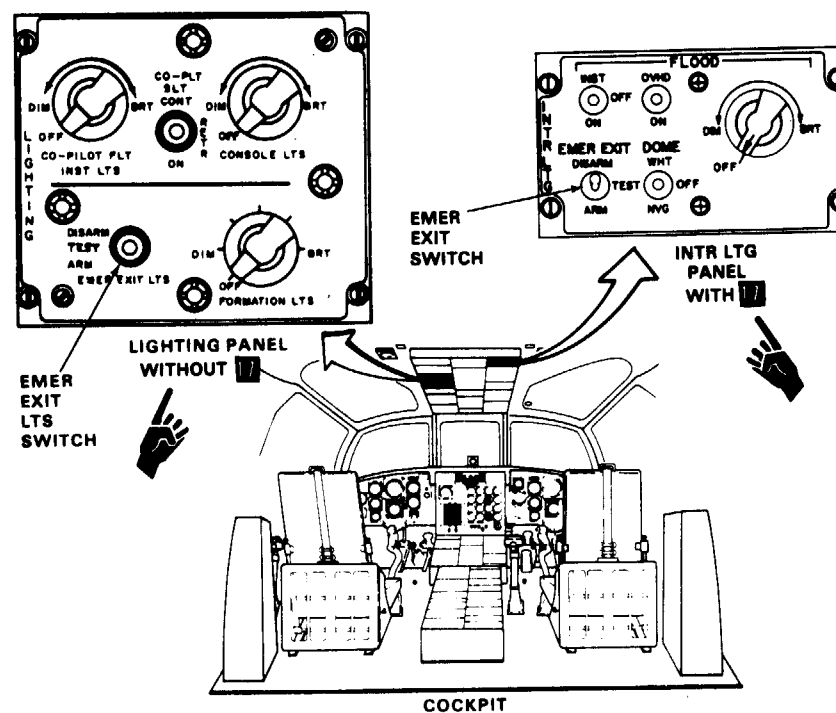
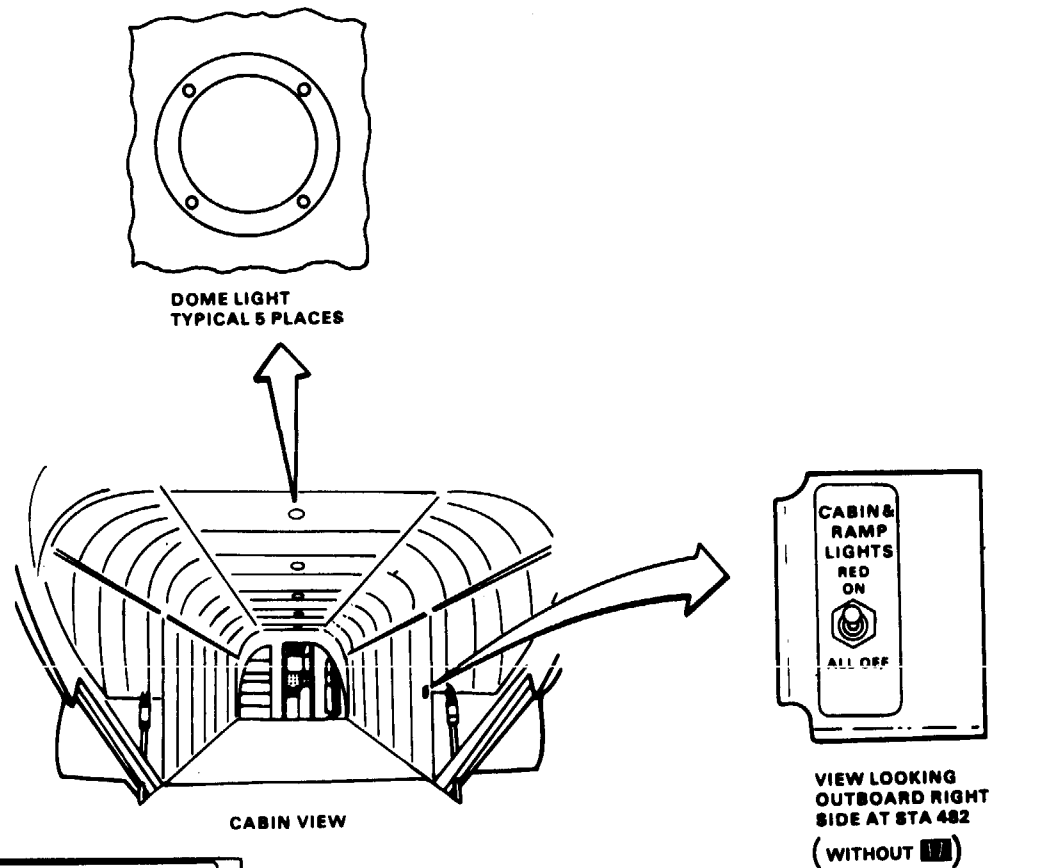
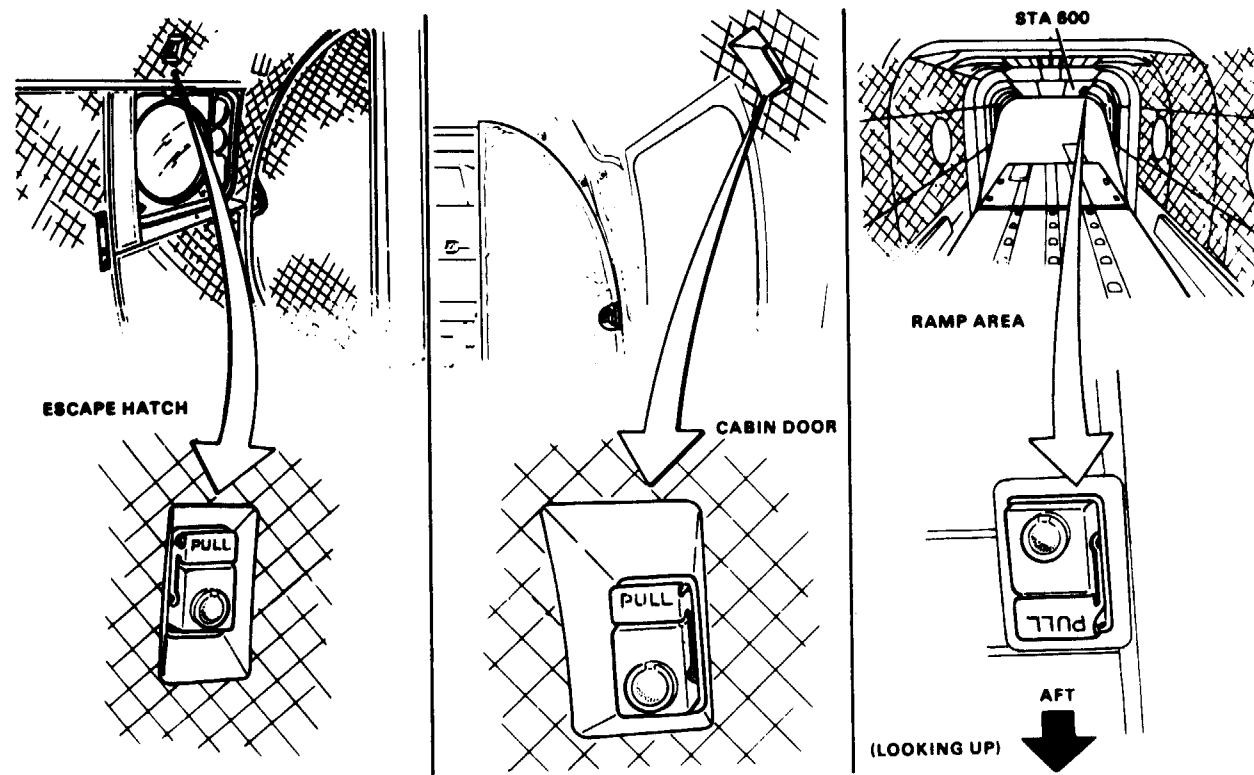

10213

17-1.4 ONE OR MORE EMERGENCY EXIT LIGHTS WILL NOT GO OUT WHEN SWITCH IS SET TO DISARM

(Continued)

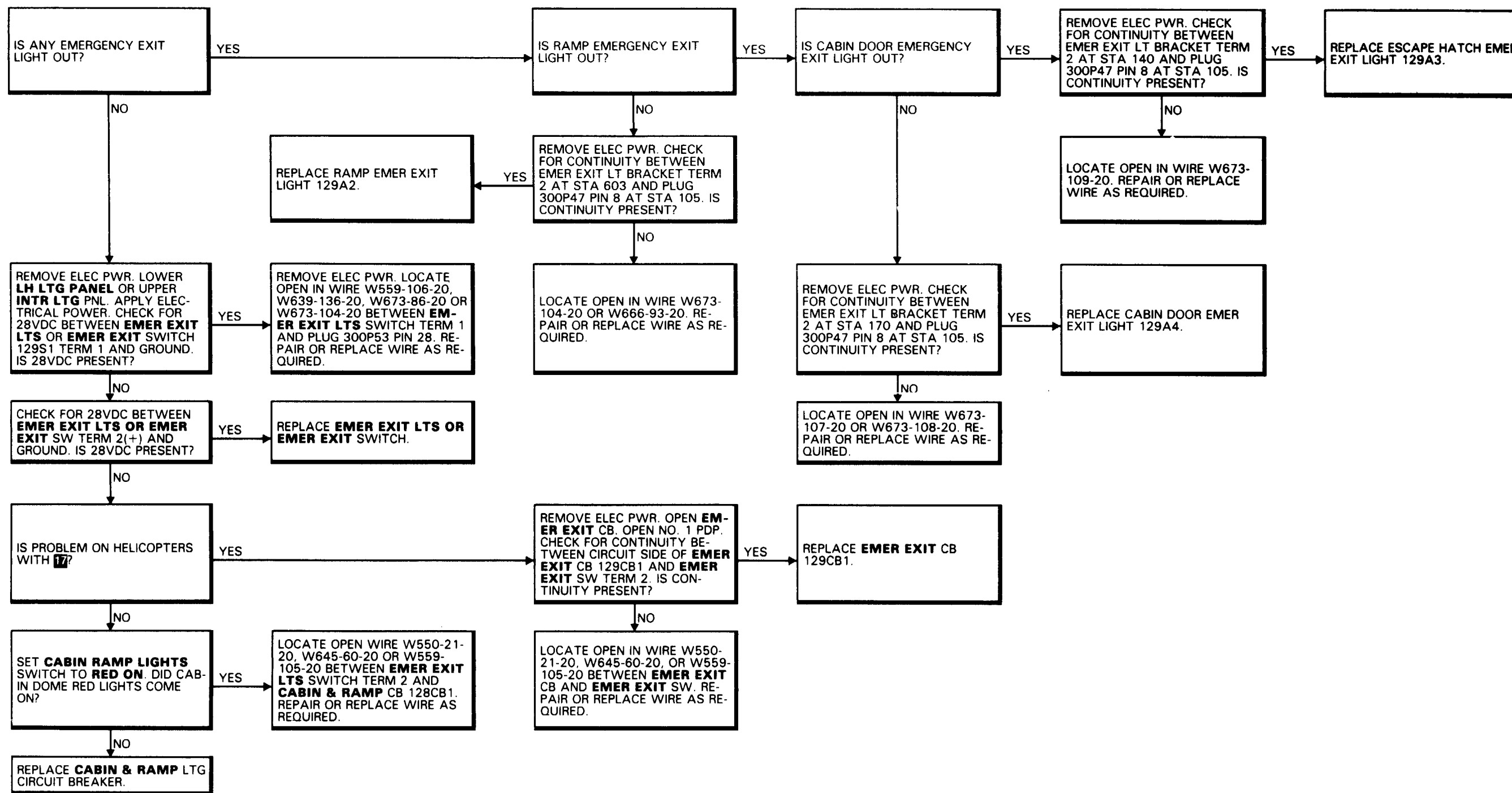

FAULT ISOLATION PROCEDURE

INITIAL SETUP

Applicable Configurations:

All

Tools:

Electrical Repairer's Tool Kit,
NSN 5180-00-323-4915
Multimeter

Materials:

None

Personnel Required:

Aircraft Electrician

References:

TM 55-1520-240-23

Equipment Condition:

TM 55-1520-240-23:
Electrical Power On
Battery Power On
Hydraulic Power Off

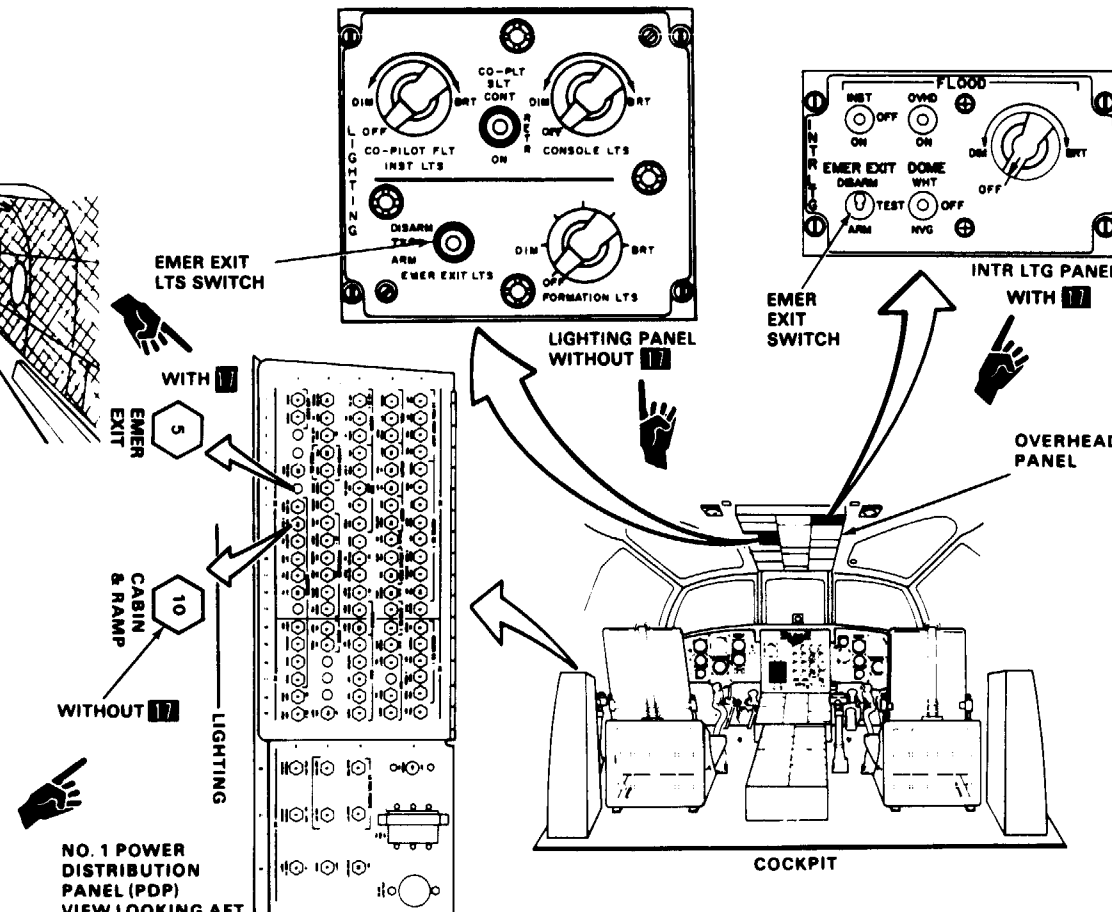
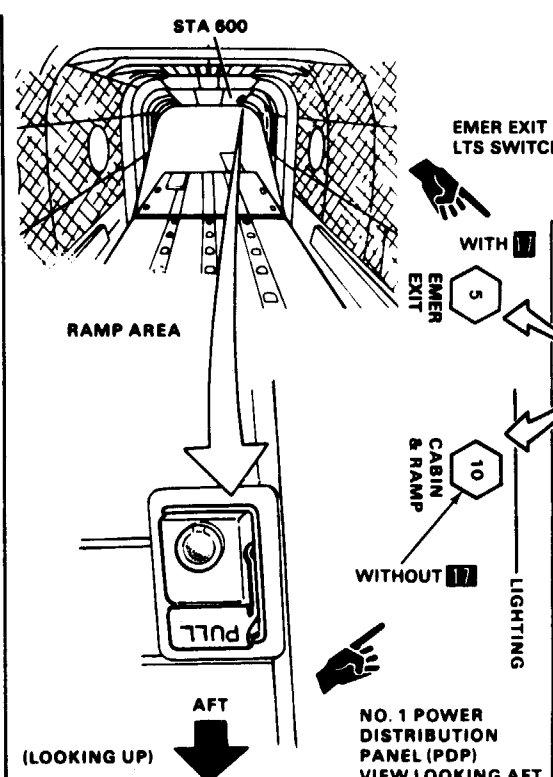
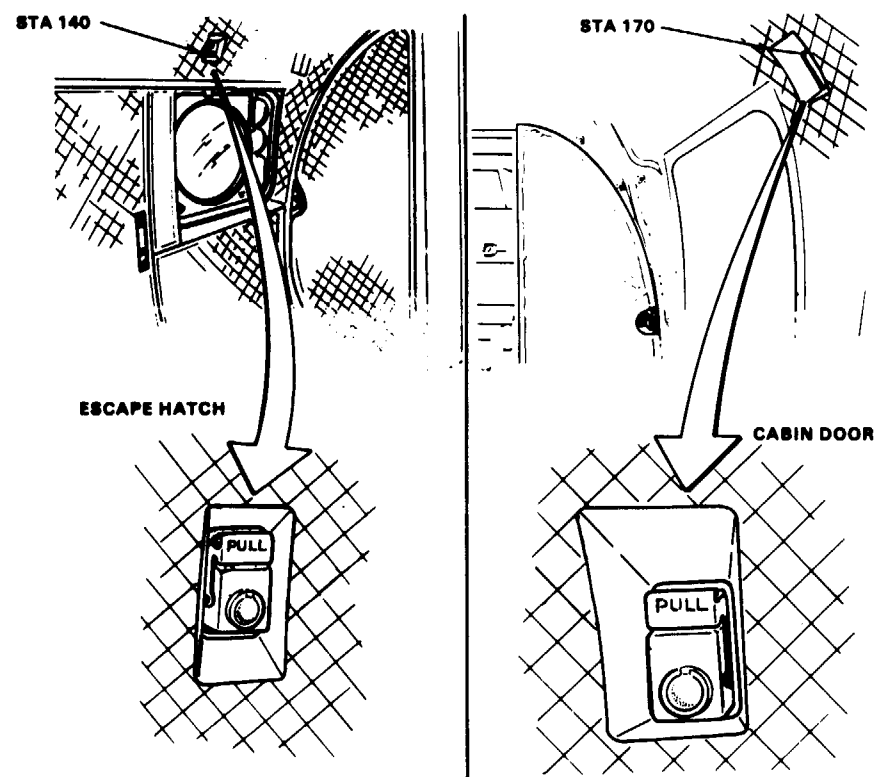
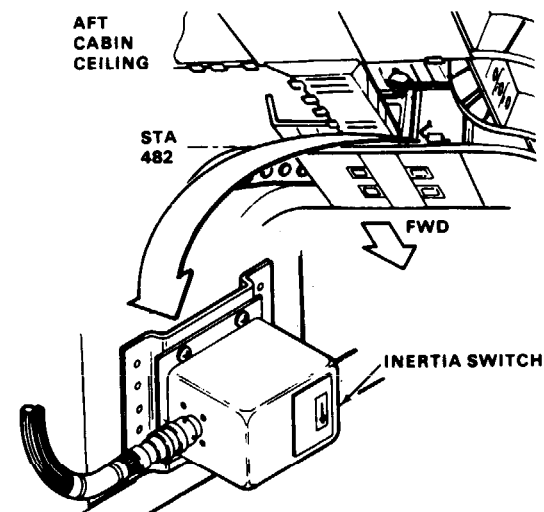

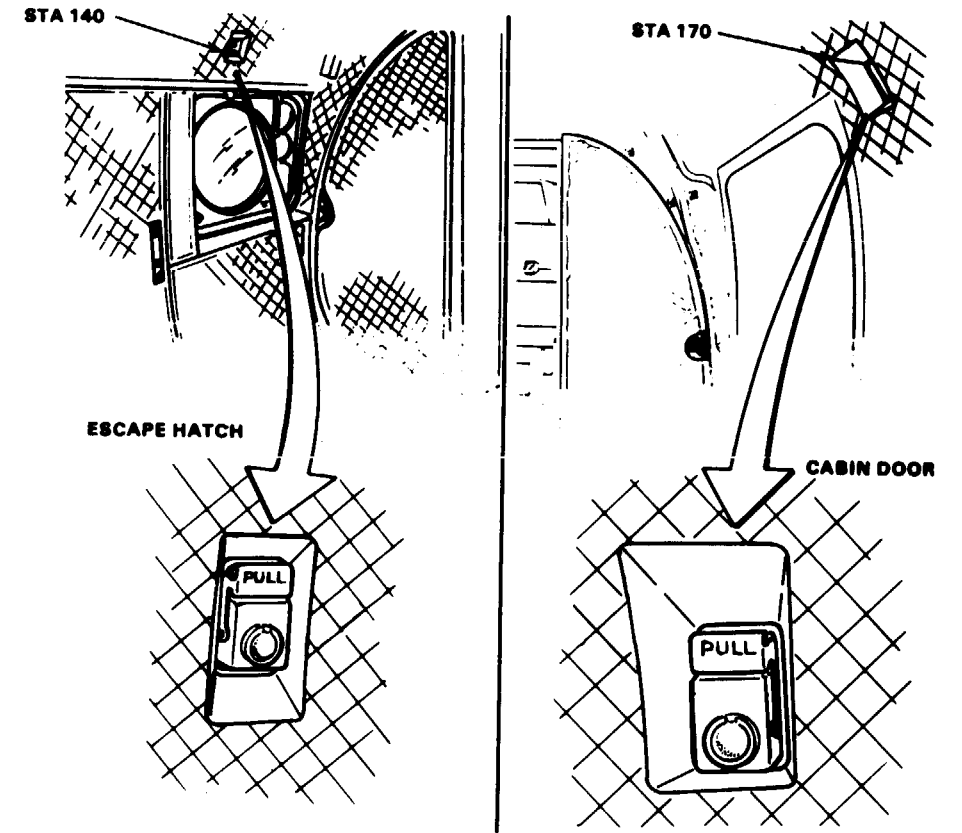
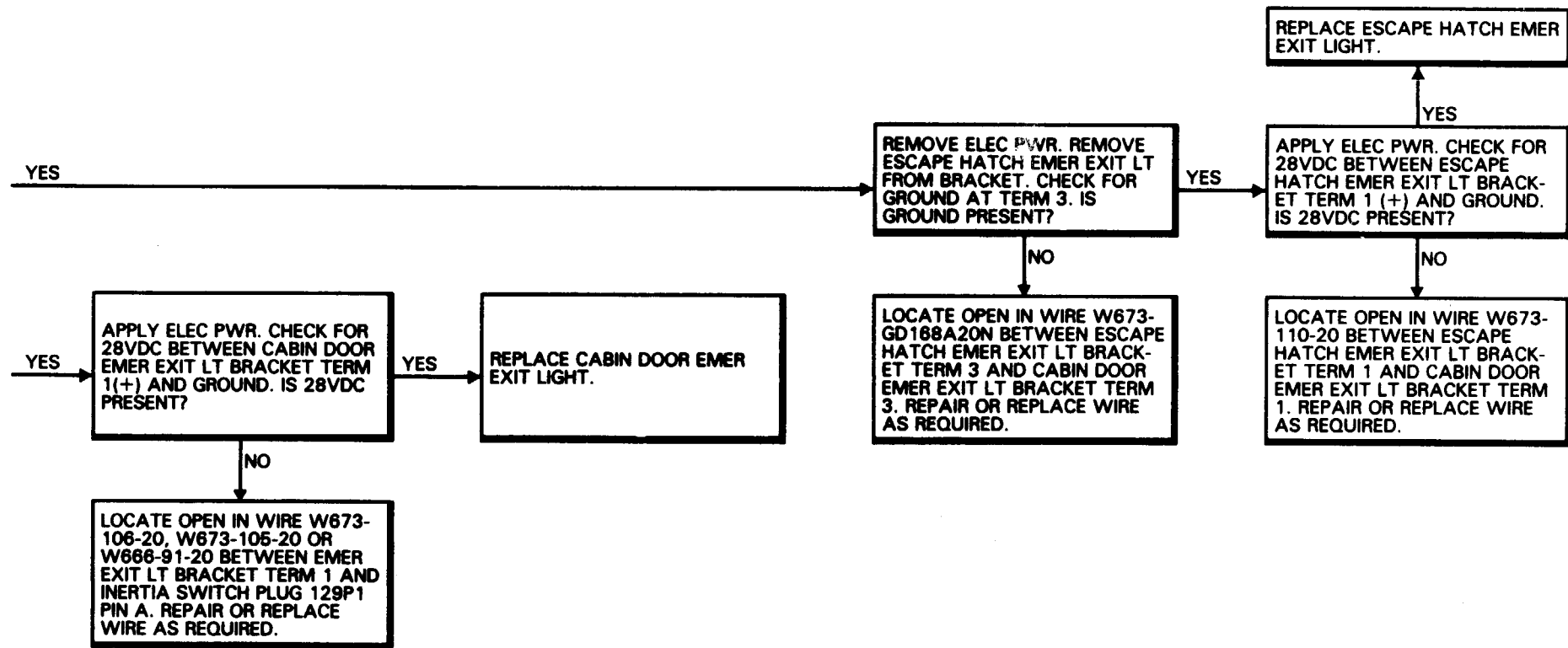

30 x 54

D145-11206-SPA

FAULT ISOLATION PROCEDURE

INITIAL SETUP

Applicable Configurations:

All

Tools:

Electrical Repairer's Tool Kit,
NSN 5180-00-323-4915
Multimeter

Materials:

None

Personnel Required:

Aircraft Electrician

References:

TM 55-1520-240-23

Equipment Condition:

TM 55-1520-240-23:

Battery Power On
Electrical Power On
Hydraulic Power Off

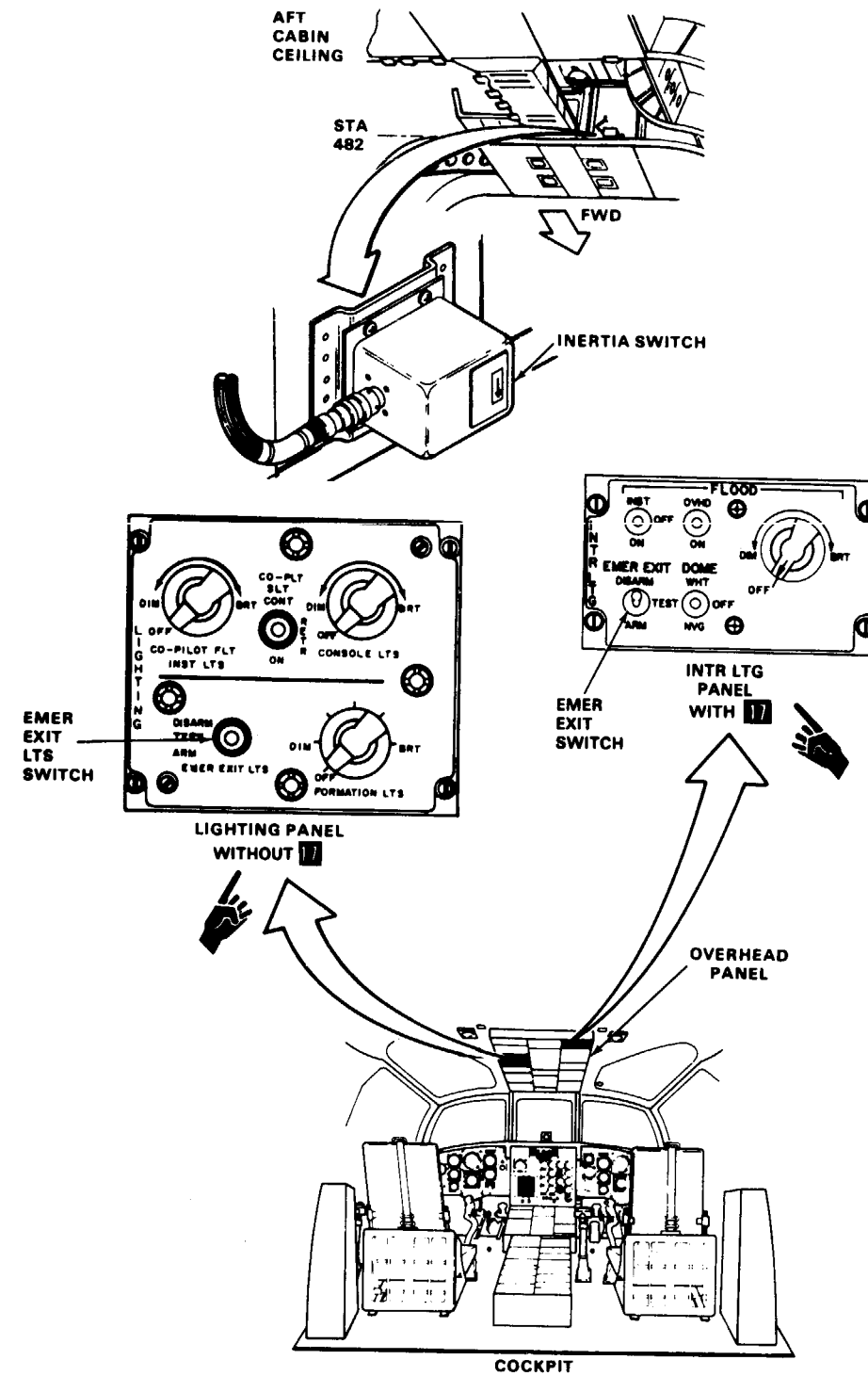
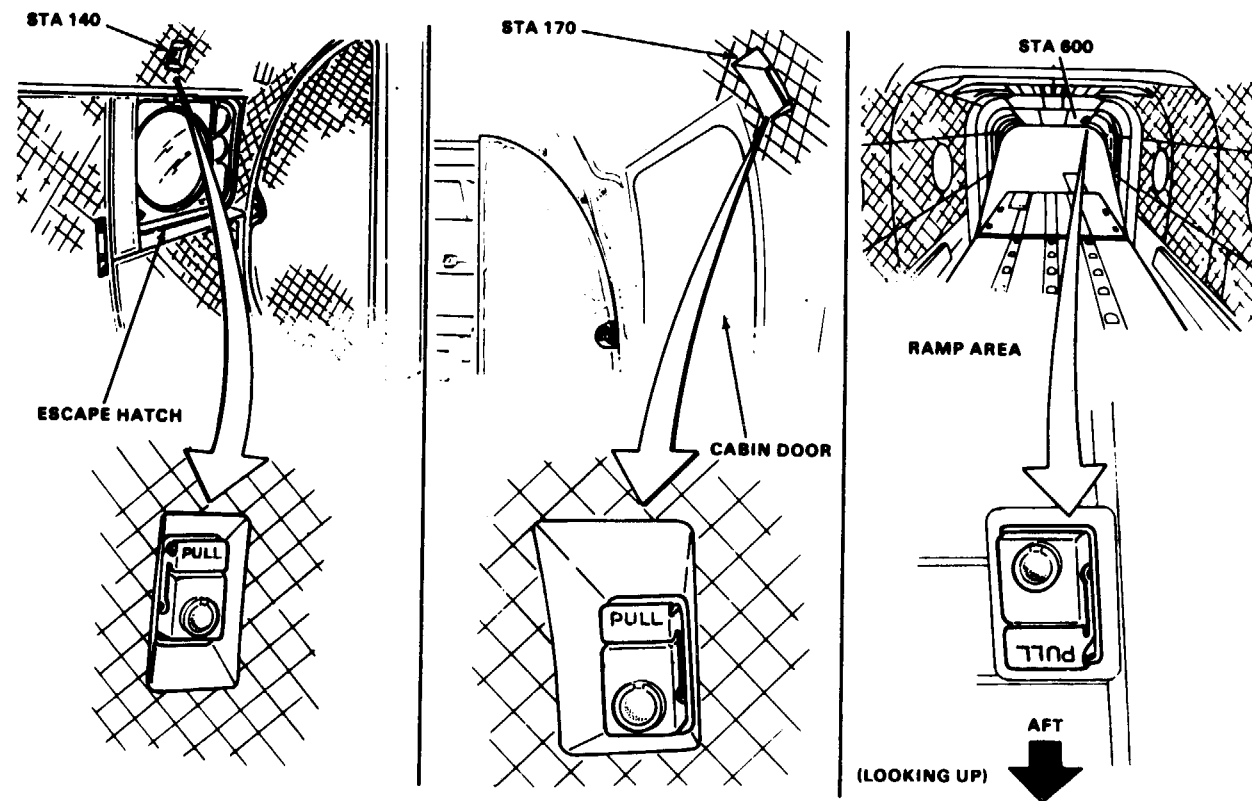

17-1.6 EMERGENCY EXIT LIGHT MAIN LAMPS COME ON WHEN SWITCH IS AT ARM (Continued)

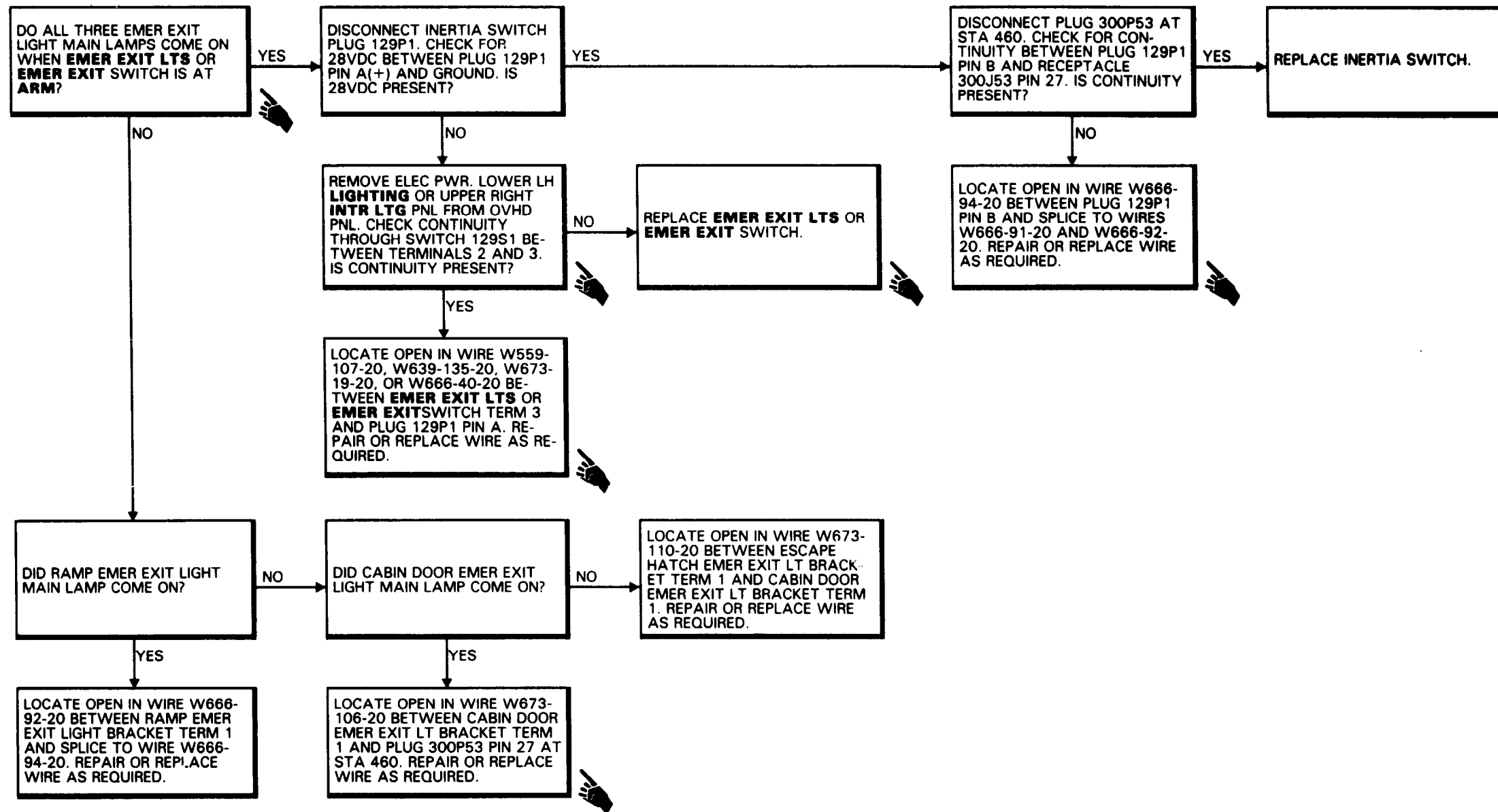

FAULT ISOLATION PROCEDURE

INITIAL SETUP

Applicable Configurations:

All

Tools

Electrical Repairer's Tool Kit,

NSN 5180-00-323-4915

Multimeter

Materials

None

Personnel Required:

Aircraft Electrician

References:

TM 55-1520-240-23

Equipment Condition:

TM 55-1520-240-23:

Electrical Power On

Battery Power On

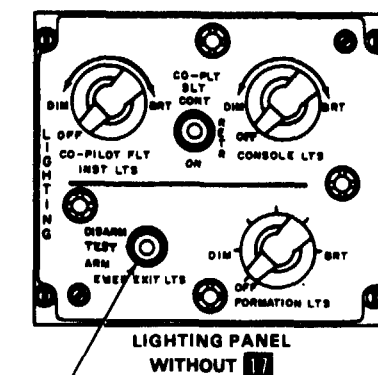
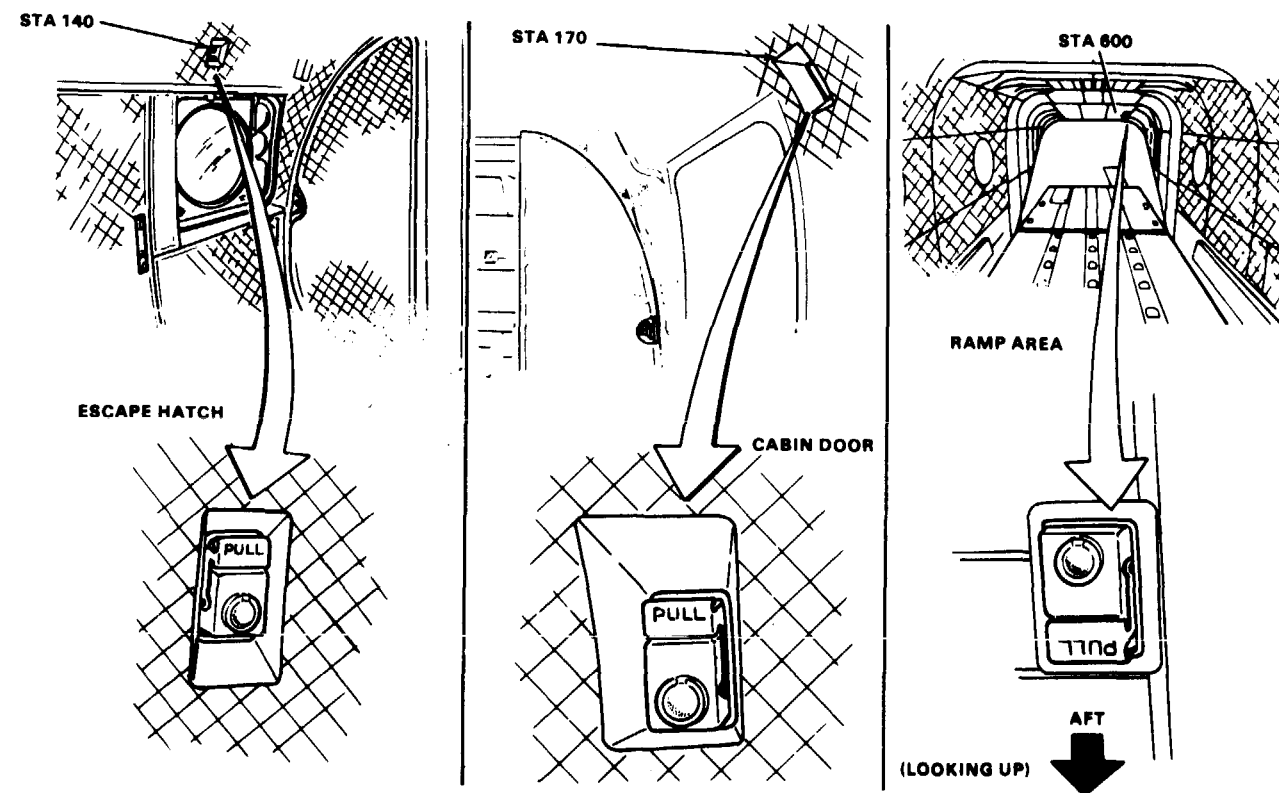
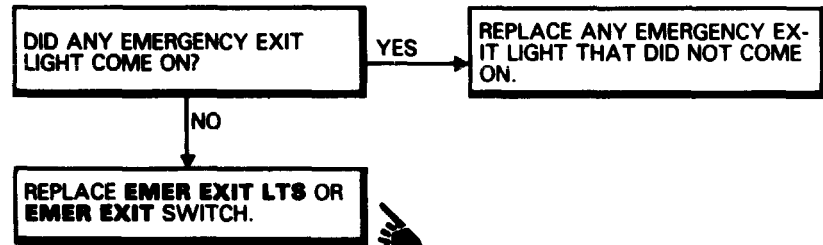

EMER EXIT LTS SWITCH

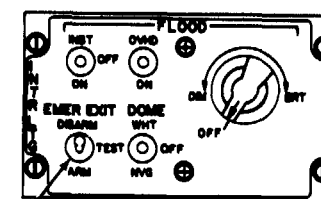

EMER EXIT SWITCH

INTR LGT PANEL WITH 17

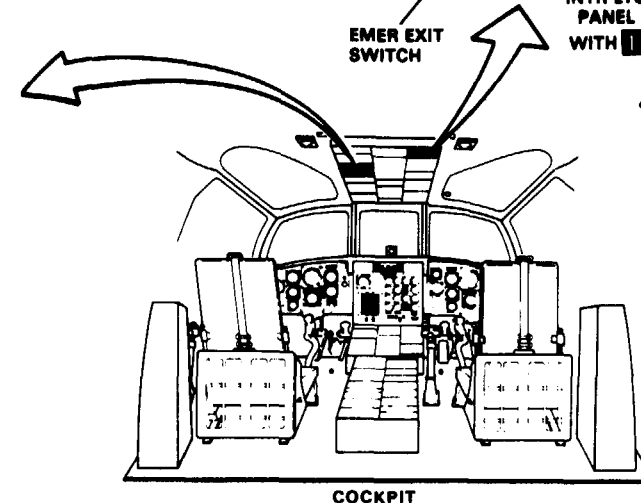

COCKPIT

FAULT ISOLATION PROCEDURE

INITIAL SETUP

Applicable Configurations:

All

Tools:

Electrical Repairer's Tool Kit,

NSN 5180-00-323-4915

Multimeter

Materials:

None

Personnel Required:

Aircraft Electrician

References:

TM 55-1520-240-23

Equipment Condition:

TM 55-1520-240-23.

Electrical Power On

Battery Power On

Hydraulic Power Off

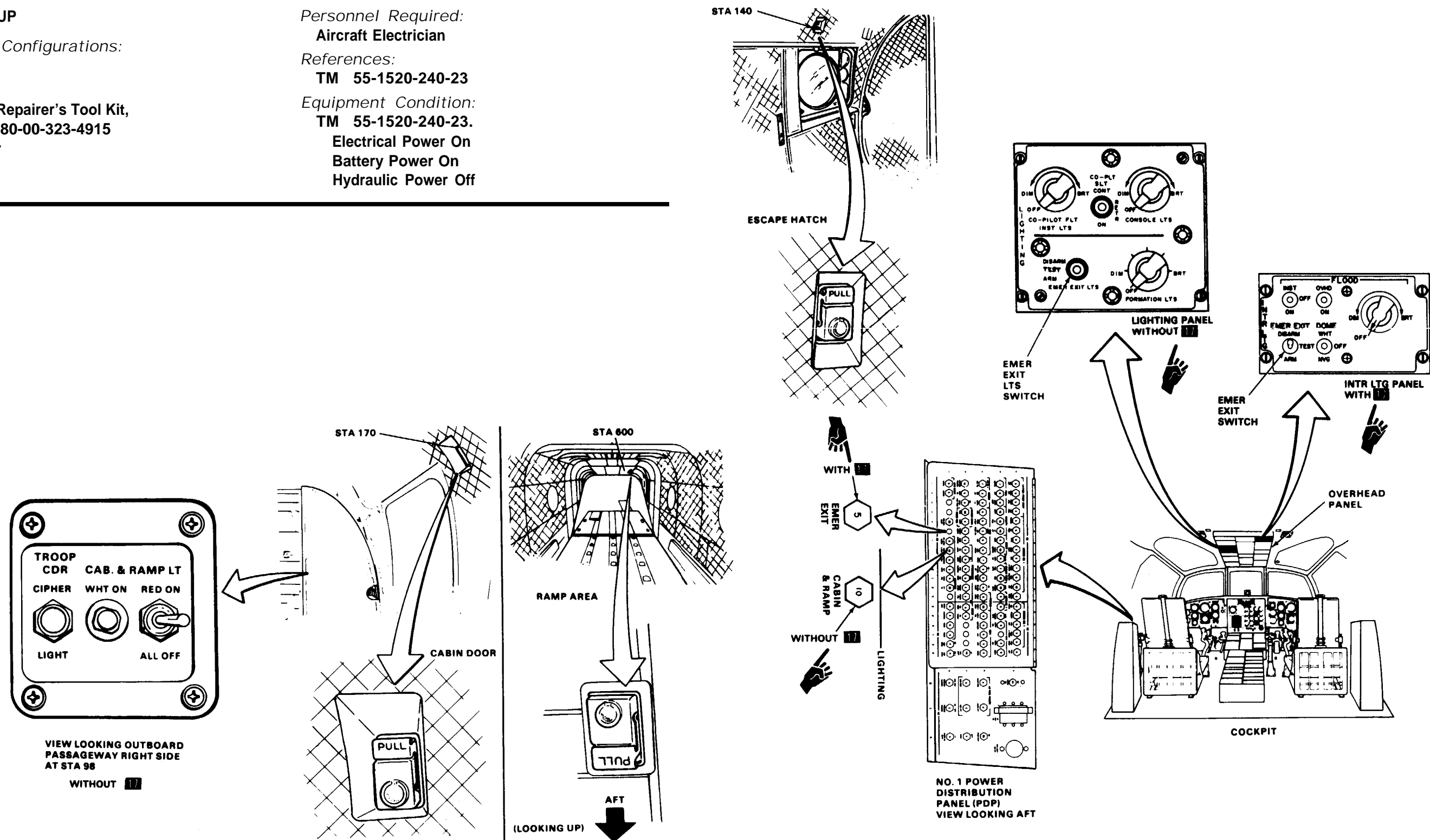

17-1.8 CHARGE INDICATOR LAMPS ON ONE OR MORE EMERGENCY EXIT LIGHTS DO NOT COME ON WHEN SWITCH IS AT DISARM (Continued)

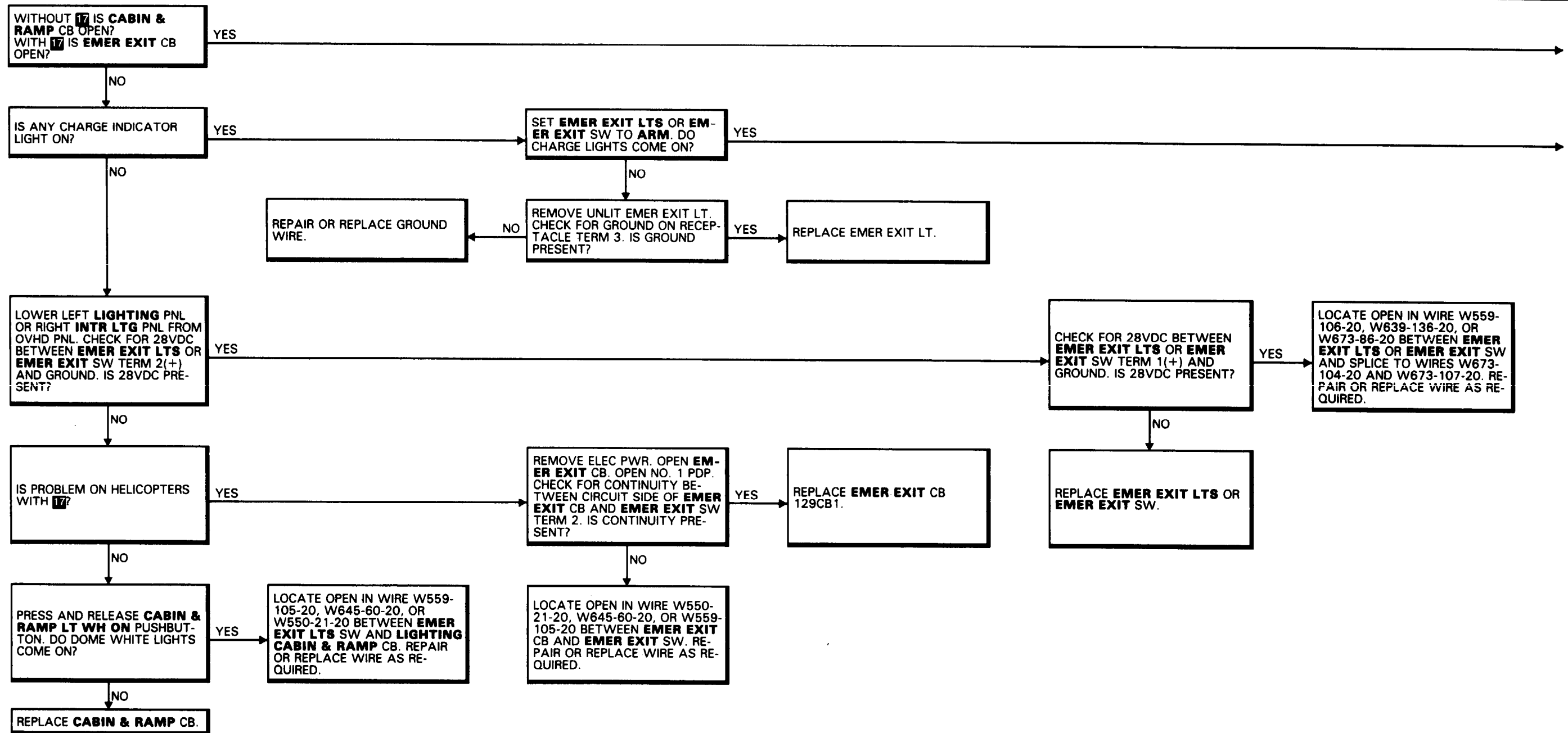

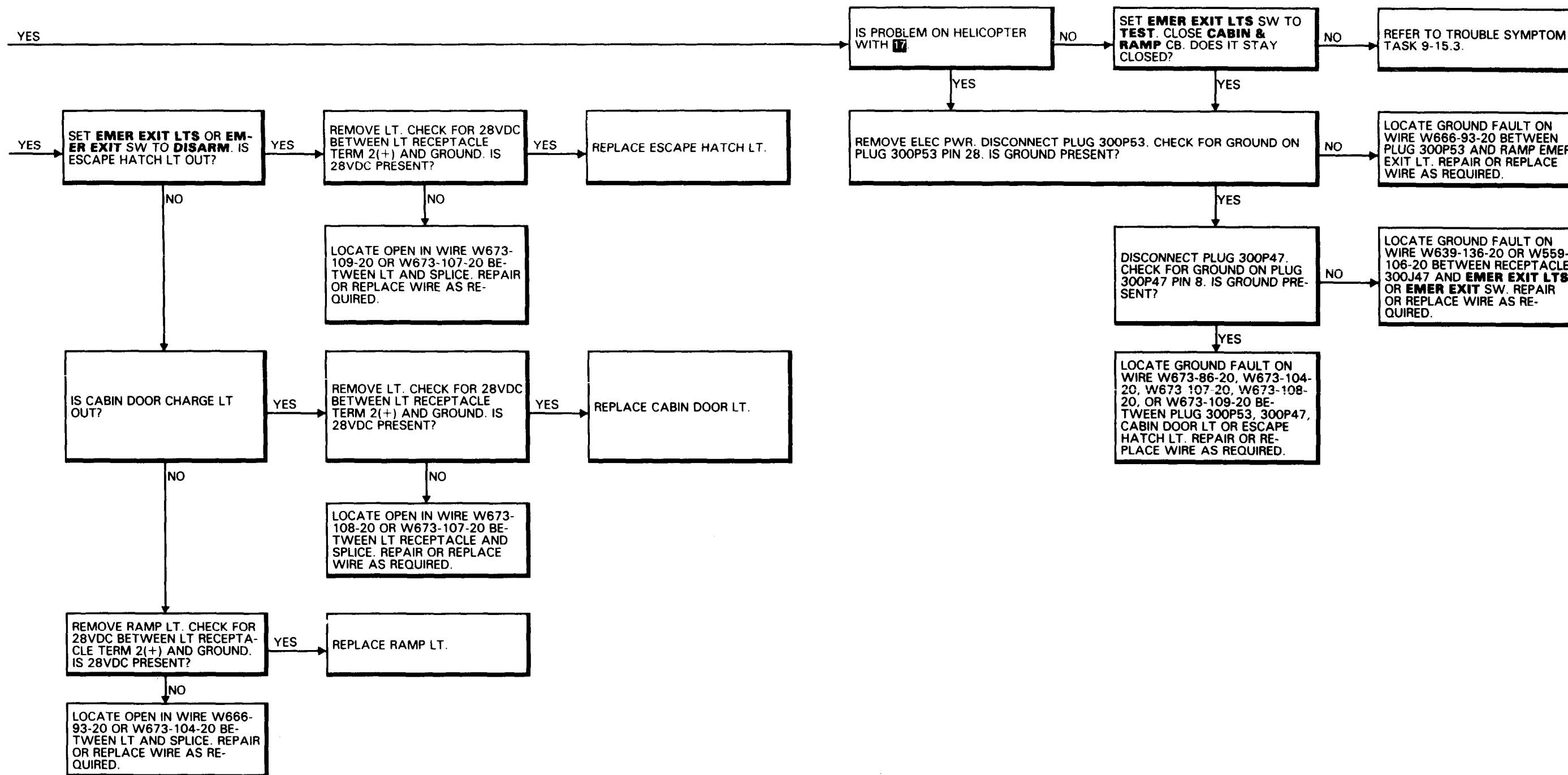

17-1.8 CHARGE INDICATOR LAMPS ON ONE OR MORE EMERGENCY EXIT LIGHTS DO NOT COME ON WHEN SWITCH IS AT DISARM (Continued)

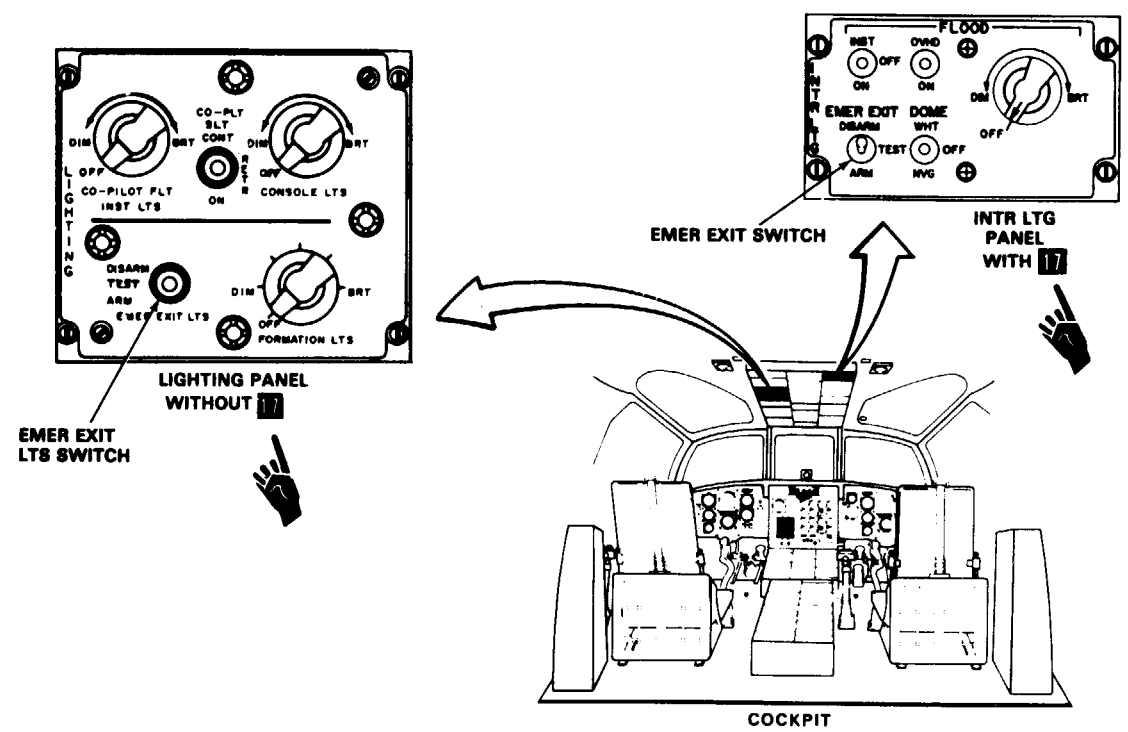
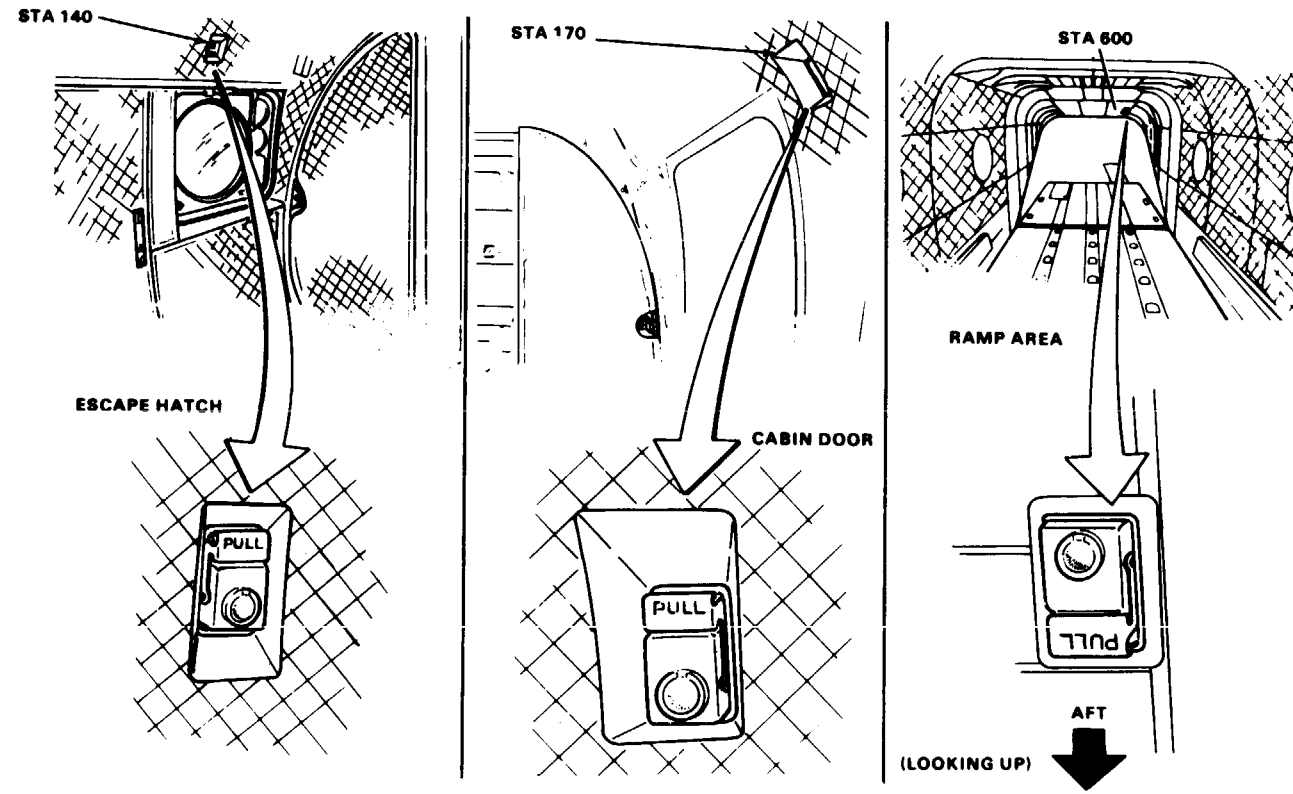

10238

CHAPTER 18
INSTALLED AVIONIC EQUIPMENT

Change 18 18-1/(18-2 blank)

**CHAPTER 18
INSTALLED AVIONIC SYSTEMS TROUBLESHOOTING**

CHAPTER OVERVIEW

Chapter 18 contains procedures for Installed Avionic Systems troubleshooting. Each avionic system and failure symptom is listed below. Included in this chapter are locations and views of all electrical connectors, receptacles, relays, and ground connections for each Installed Avionic System.

Refer to TM 55-1520-240-23 for required Avionic System maintenance procedures.

SYSTEM	PARA
GLOBAL POSITIONING	18-1
ALTITUDE VOICE WARNING SYSTEM (RADAR ALTIMETER)	18-2
DOPPLER/GPS NAVIGATION SYSTEM (DGNS)	18-3
HF LIAISON FACILITY	18-4

FAILURE SYMPTOM LIST

GLOBAL POSITIONING SYSTEM

SYMPTOM	TASK
GPS DISPLAY DOES NOT TURN ON OR VARY WITH CDU BRT CONTROL	18-1.4
NO MOVEMENT OF GPS RCVR TIME TOTALIZING METER	18-1.5
GPS CDU DISPLAYS "FAIL" MESSAGE	18-1.6

SYMPTOM	TASK
GPS SYSTEM TRACKS LESS THAN FOUR SATELLITES AND ESTIMATED POSITION ERROR (EPE) IS NOT WITHIN LIMITS OF THE SYSTEMS FIGURE OF MERIT (FM)	18-1.7
DATA LOADER MODULE INFORMATION DOES NOT LOAD INTO GPS SYSTEM BUT NO ERROR MESSAGE APPEARS ON CDU	18-1.8
KYK-13 KEY LOADING DISCREPANCIES	18-1.9

SYMPTOM	TASK
GPS ALERT INDICATOR DISCREPANCIES	18-1.10
PILOT/COPILOT HSI DISCREPANCIES	18-1.11
GPS SYSTEM WILL NOT ZEROIZE	18-1.12
GPS SYSTEM WILL NOT RETAIN LOADED DATA AFTER AIRCRAFT POWER IS REMOVED	18-1.13

GO TO THE NEXT PAGE

FAILURE SYMPTOM LIST (Continued)

ALTITUDE VOICE WARNING SYSTEM
(RADAR ALTIMETER)

SYMPTOM	TASK
ALTITUDE VOICE WARNING MESSAGE NOT AUDIBLE IN PILOT, COPILOT, OR AFT STATION/ HOIST OPERATOR'S HEADSET WHEN PILOT'S RADAR ALTIMETER POINTER IS BELOW OR ABOVE PRESET ALTITUDE LIMITS	18-2.4
ALTITUDE VOICE WARNING MESSAGE VOLUME DOES NOT FLUCTUATE WHEN PRESS-TO-TEST KNOB IS MOMENTARILY DEPRESSED	18-2.5
ALTITUDE VOICE WARNING MESSAGE IS AUDIBLE WHEN ALTITUDE POINTER IS WITHIN THE HI/LO SET INDEX ENVELOPE	18-2.6

CHAPTER 18
INSTALLED AVIONIC SYSTEMS TROUBLESHOOTING

CHAPTER OVERVIEW

FAILURE SYMPTOM LIST (Continued)

DOPPLER/GPS NAVIGATION SYSTEM (DGNS)

SYMPTOM	TASK	SYMPTOM	TASK	SYMPTOM	TASK
EDGE LIT PANEL DOES NOT LIGHT OR VARY	18-3.4	GPS ALERT INDICATOR DOES NOT ILLUMINATE	18-3.7	INDICATIONS ON THE FOUR-LINE DISPLAY AND HSI ARE NOT THE SAME	18.3.10
CDU MAL LAMP AND ALL LED SEGMENTS ARE NOT ILLUMINATED	18-3.5	PRESENT POSITION NOT DISPLAYED ON CDU	18-3.8	GPS DOES NOT ZEROIZE	18-3.11
CDU DISPLAY NOT GO ALL	18-3.6	CDU DOES NOT DISPLAY DOWNLOAD WAYPTS DURING WAYPOINT LOADING	18-3.9	GPS HAVEQUICK TIMING NOT WORKING	18-3.12

INSTALLED AVIONIC SYSTEMS ELECTRICAL COMPONENT
LOCATION AND CONFIGURATION LIST

REF DESIG	TYPE	MATE WITH/LOCATION	STATION LOCATION		
			FS	WL	BL
ASN149GD002		CANTED CONSOLE - FWD FLOOR	53	-15	6L
ASN149GD003		CANTED CONSOLE - FWD FLOOR	53	-15	6L
GD306		HEATER COMPARTMENT	95	6	45R
GD319		AVIONICS COMPT - LEFT SIDE	118	6	50L
TB4		CONSOLE - FWD FLOOR	50	-17	0
TB6		CONSOLE - FWD FLOOR	50	-17	0

REF DESIG	PART NUMBER	TYPE	MATE WITH/LOCATION	STATION LOCATION		
				FS	WL	BL
181P6	MS27484518B32SA		CTR CONSOLE, RT-1167/ARC-164, UHF RCVR/XMTR			
185P1	MS27473T18B35S	60	CONSOLE, RT-2585/APX-100, IFF			
187P26	M28748/6-G30L1A	62	CONSOLE, CPLT INTPH CONT PNL			
187P27	M28748/6-G30L1A	62	CONSOLE, PLT INTPH CONT PNL			
187P31	M28748/6-G30L1A	62	CABIN, AFT INTPH CONT PNL	485	0	50L
195P2	MS27473T10B35SA		PLT INSTR PNL, RAD ALT RT IND			
196P2	MS3476W16-26S	24	PLT INSTR PNL, AIMS ALT			
197P6	MS27484T18B35P		CTR INSTR PNL; CDU, J2 - DOPPLER CDU / 199J14 - GPS DISC	50	-15	0
199CR1	JTXM19500/51902		ELECTRONICS COMPARTMENT, GPS FILL PANEL	108	27	32L
199DS1	923-104-28-8		CTR INSTR PNL, GPS ALERT IND			
199P1	D38999/26FB98SN		ELECTRONICS COMPARTMENT, R-2400/A, GPS RCVR	108	28	29L
199S1	MS24523-23		CTR INSTR PNL, GPS ZEROIZE SWITCH			
199T1	M27/54-16B		CONSOLE - FWD FLOOR	50	-17	0
199P2	D38999/26FH35SN		ELECTRONICS COMPARTMENT, R-2400/A, GPS RCVR	108	27	29L
199S2	MS25089-1C		ELECTRONICS COMPARTMENT, GPS FILL PANEL	108	27	34L
199P3	D38999/26FG41SN		CONSOLE CANTED, C-11702/UR, GPS CONTROL DISPLAY UNIT			
199P4	MS27473T12F35S		ELECTRONICS COMPARTMENT, DATA LOADER RECEPTACLE	103	28	33L
199J5	ON241775-1		ELECTRONICS COMPARTMENT, KYK-13 RECEPTACLE	108	27	33L
199J6	M83723/73A2461N		CONSOLE, UNDERFLOOR DISC	80	-30	3R
199P6	M83723/76A2461N		CONSOLE, UNDERFLOOR DISC	79	-30	3R
199P7	M39012/26-0503		ELECTRONICS COMPARTMENT, R-2400/A, GPS RCVR	108	27	29L
199P8	M39012/01-0503		ELECTRONICS COMPARTMENT, R-2400/A, GPS RCVR	108	27	27L
199P9	M39012/26-0503		CABIN OVERHEAD, AM-7314/URN, AE-4 ANTENNA ELECTRONICS, GPS	229	50	17L
199P10	C02		CABIN OVERHEAD, AM-7314/URN, AE-4 ANTENNA ELECTRONICS, GPS	228	50	17L
199P11	(per MIL-C-39012/27) M39012/01-0503		CABIN OVERHEAD, AM-7314/URN, AE-4 ANTENNA ELECTRONICS, GPS	227	50	17L
199P12	C11		NO. 2 TUNNEL COVER DOOR,	239	55	2L
199P13	(per MIL-C-39012/30) MS27467T25B29P		AS-3922/URN FRPA-3, GPS ANTENNA ELECTRONICS COMPARTMENT, CV-3338/ASN-128, DOPPLER SDC	108	27	25L
199J14	MS27472T18B35S		CTR INSTR PNL, 197P6 - GPS DISC	50	-15	0
300J6	M83723-74A24616	40	NO. 2 PDP			
300P6	M83723-75A24616	43	NO. 2 PDP			

DOPPLER GPS/NAVIGATION SYSTEM ELECTRICAL COMPONENT LOCATION AND CONFIGURATION LIST

REF DESG	PART NUMBER	TYPE	MATE WITH/LOCATION	STATION LOCATION			REF DESG	PART NUMBER	TYPE	MATE WITH/LOCATION	STATION LOCATION		
				FS	WL	BL					FS	WL	BL
066P1	MS27473T22B2S	7	HSI-PLT	45	0	25R	197P4	MS27467T25B29P	B	SIG DATA CONVERTER	108	27	25L
066P2	MS27473T22B2S	7	HSI-CPLT	45	0	25L				CV-3338A/ASN-128B			
181P6	MS27473T18B32SA	58	RT-1167C/ARC-164 UHF	65	-20	0	197P5	MS27484T20B16S	64	COMP DIS UNIT (CDU)	52	-20	2R
181P1	MS27473T18B32S	58	RT-1167C/ARC-164 UHF	65	-20	0				CP-1252C/ASN-128B			
185P1	MS27473T18B35S	60	RT-2585/APX-100 IFF	52	-20	10L	197P6	MS27484T18B35P	60	COMP DIS UNIT (CDU)	52	-20	2L
186P4	MS27467T19B35S	60	RT-1749/URC							CP-1252C/ASN-128B			
			AN/ARC-220 HF R/T	118	-25	30L	197P7	2031-5011-00	COAX	SIG DATA CONVERTER	108	30	30L
196P2	MS3476W16-26S	24	AAU-32/A PILOT ALTIMETER	45	10	12L				CV-3338A/ASN-128B			
197P8	2031-5011-00	COAX	ANTENNA 22433-40	239	55	3L	197P9	MS27467T15B35S	B	SIG DATA CONVERTER	108	30	28L
197P1	MS27484T14B35S	A	RCVR/XMTR ASSY							CV-3338A/ASN-128B			
			RT-1193A/ASN-128	110	-40	0	P2002R	D38999/26WH35SN	C	ANVIS/HUD SIG DATA CONV			
197P11	MS27473T12F35S	8	DATA LOADER RECEPTACLE	105	27	35L				CV-4229/AVS-7	105	-10	29L
197P2	MS27467T17B99S	23	SIG DATA CONVERTER	108	27	29L	197J10	M83723/73A2461N	43	PEDESTAL DISCONNECT PANEL	80	-30	0
			CV-3338A/ASN-128B				197P10	M83723/76A2461N	43	PEDESTAL DISCONNECT PANEL	80	-30	0
197P3	MS27467T21B41P	26	SIG DATA CONVERTER	108	27	27L							
			CV-3338A/ASN-128B										

DOPPLER GPS/NAVIGATION SYSTEM ELECTRICAL COMPONENT LOCATION AND CONFIGURATION LIST (Continued)

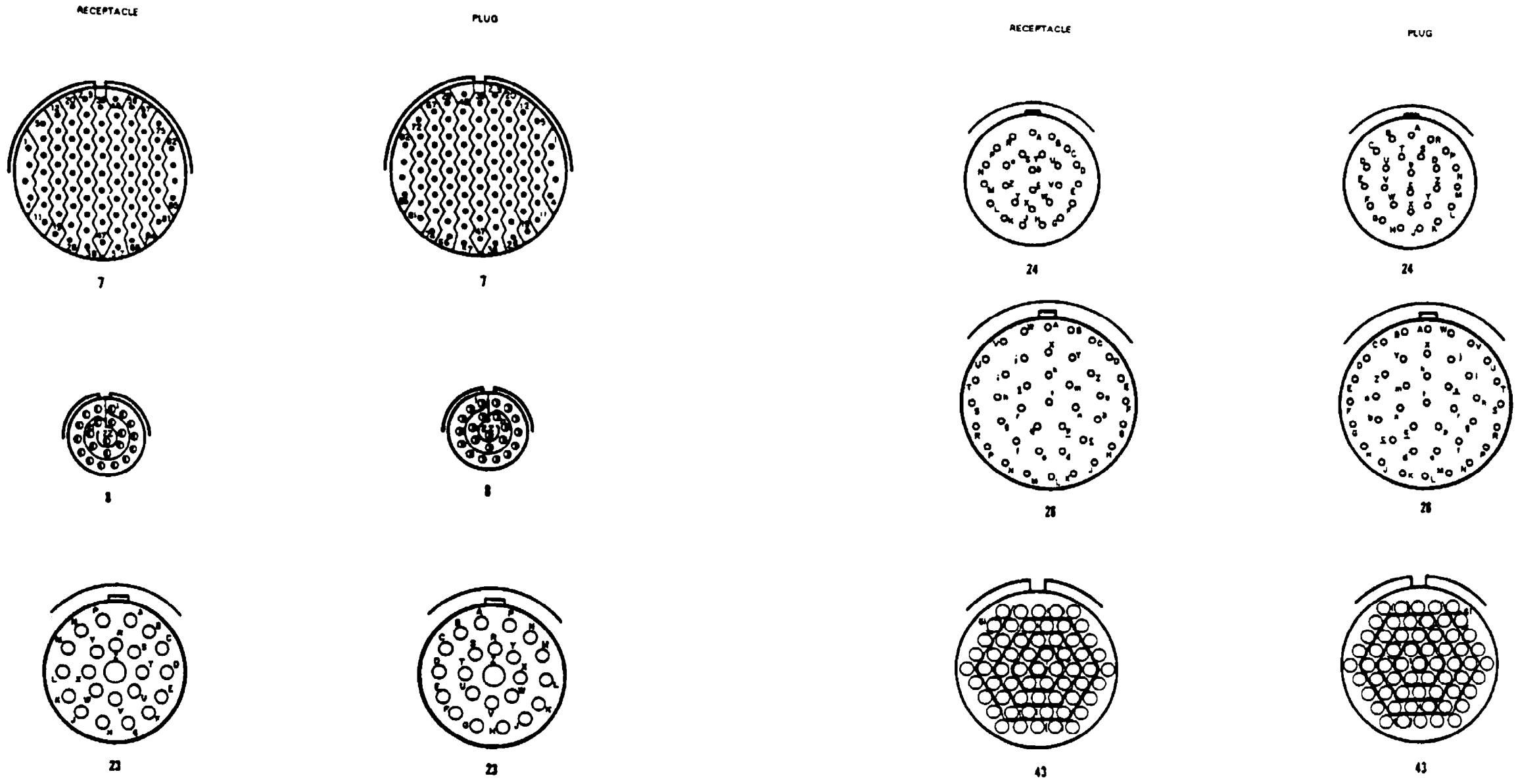

DOPPLER GPS/NAVIGATION SYSTEM ELECTRICAL COMPONENT LOCATION
AND CONFIGURATION LIST (Continued)

RECEPTACLE

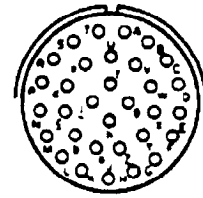

58

PLUG

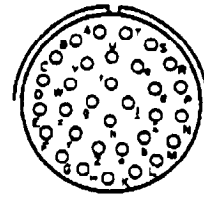

58

RECEPTACLE

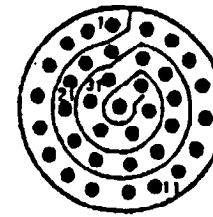

A

PLUG

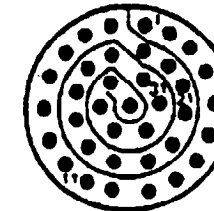

A

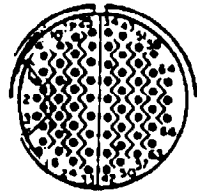

60

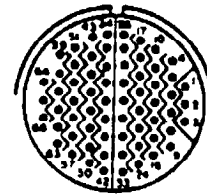

60

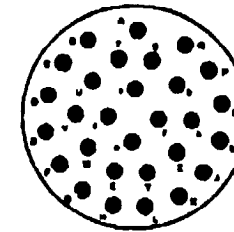

B

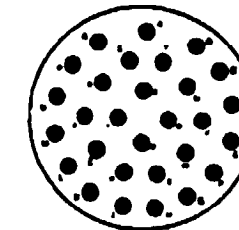

B

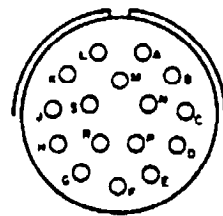

64

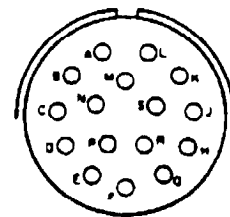

64

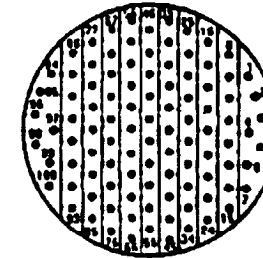

C

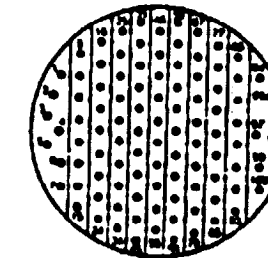

C

HF LIAISON FACILITY ELECTRICAL COMPONENT LOCATION AND CONFIGURATION LIST (Continued)

RECEPTACLE

PLUG

RECEPTACLE

PLUG

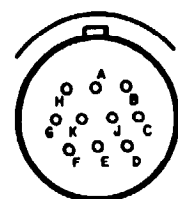

17

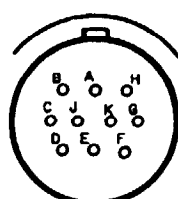

17

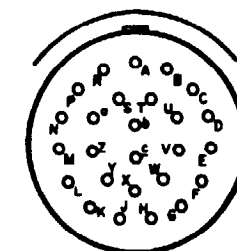

24

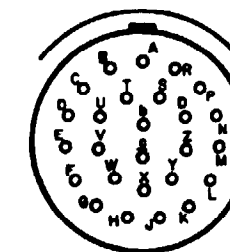

24

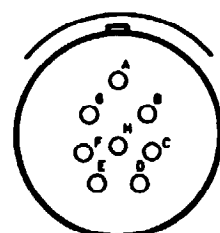

22

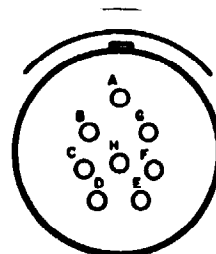

22

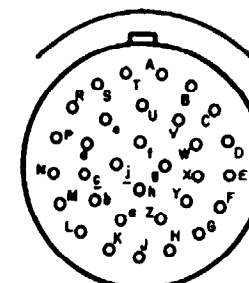

25

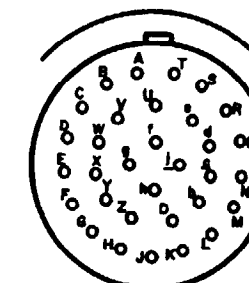

25

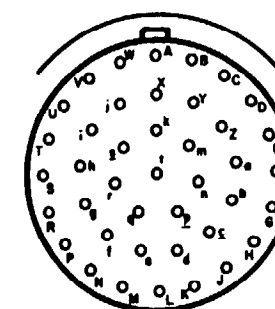

26

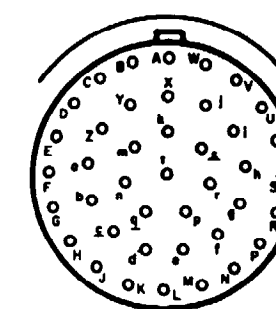

26

18-1 GLOBAL POSITIONING SYSTEM

|

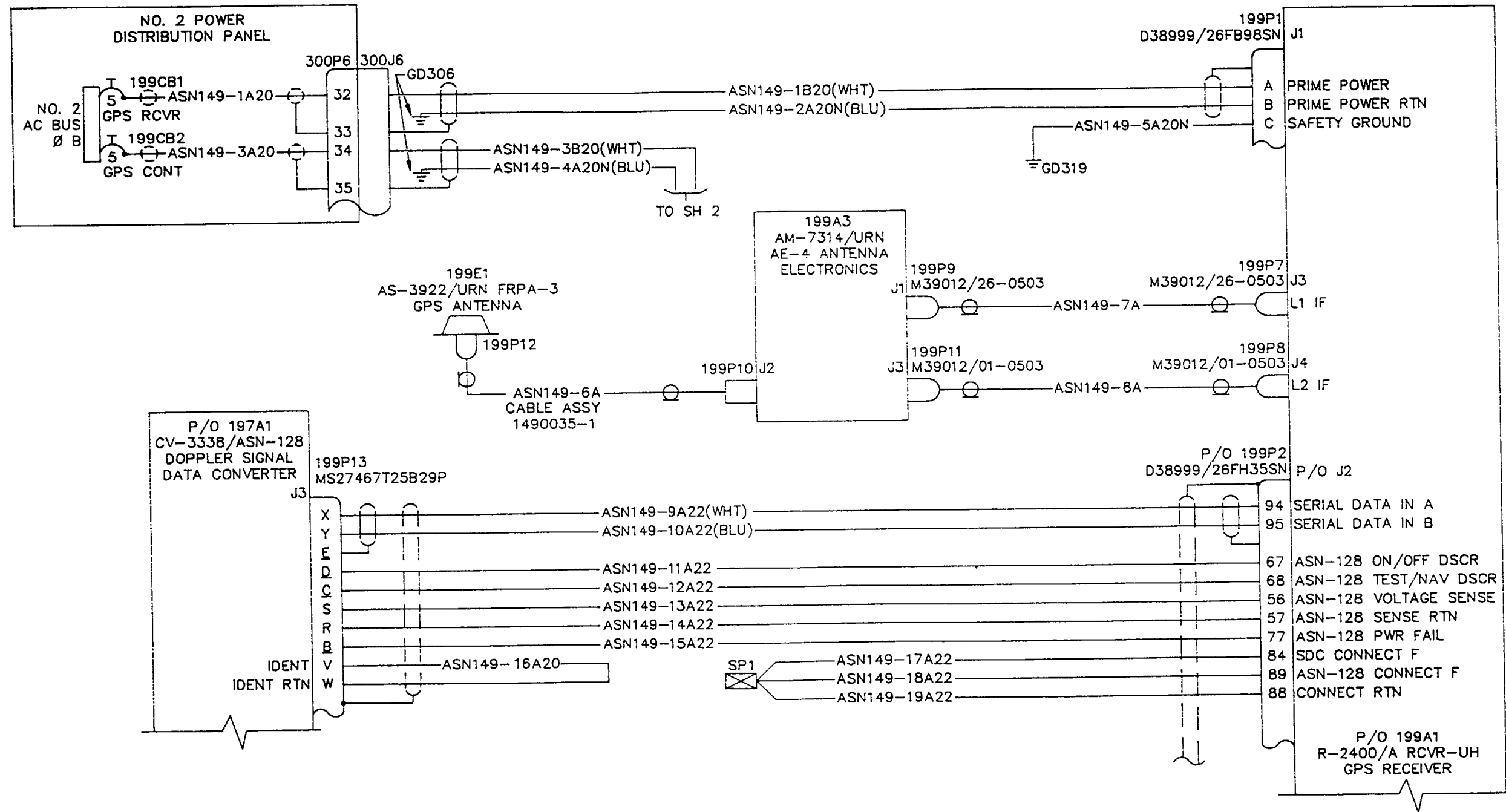

GO TO NEXT PAGE

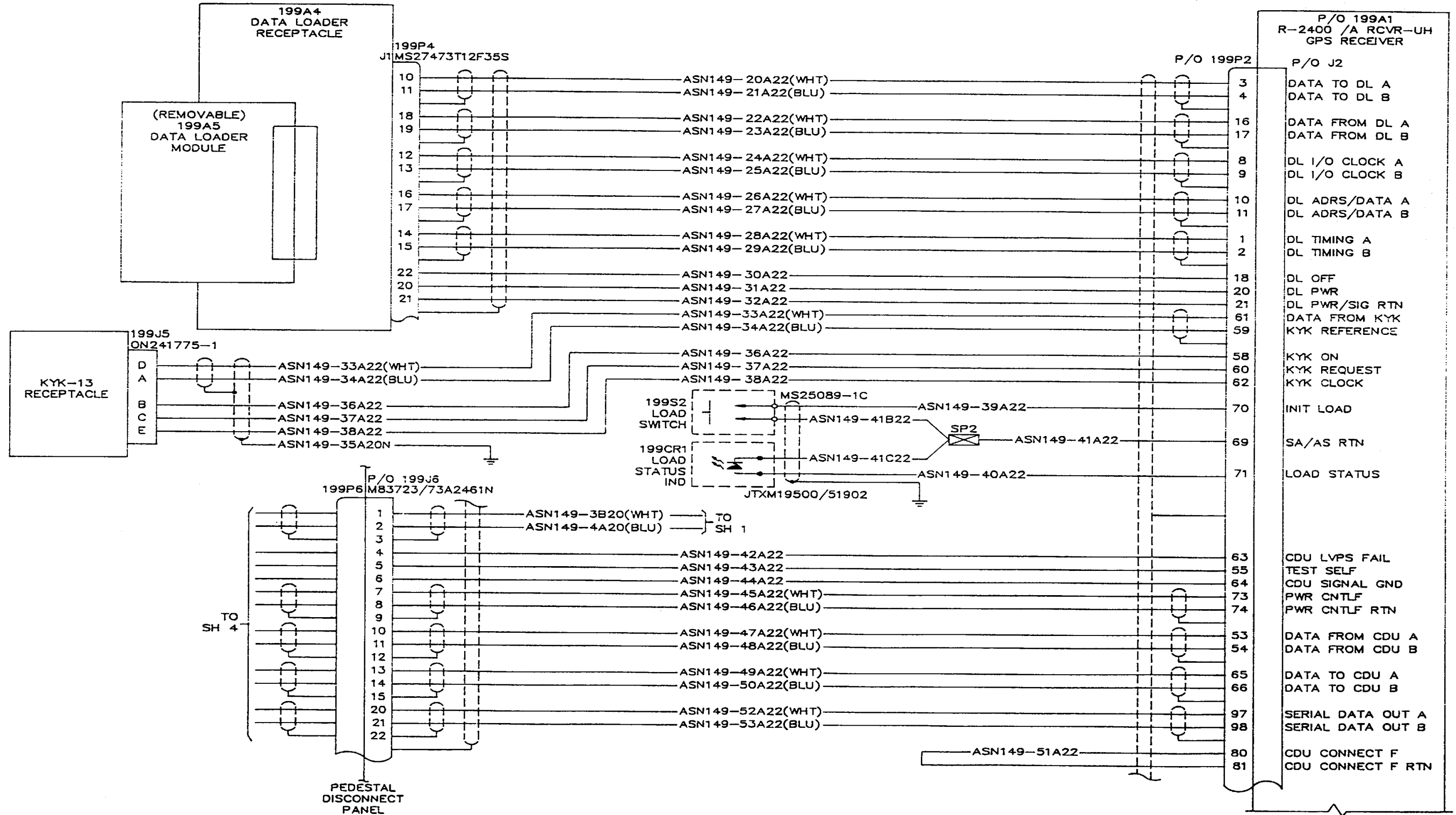

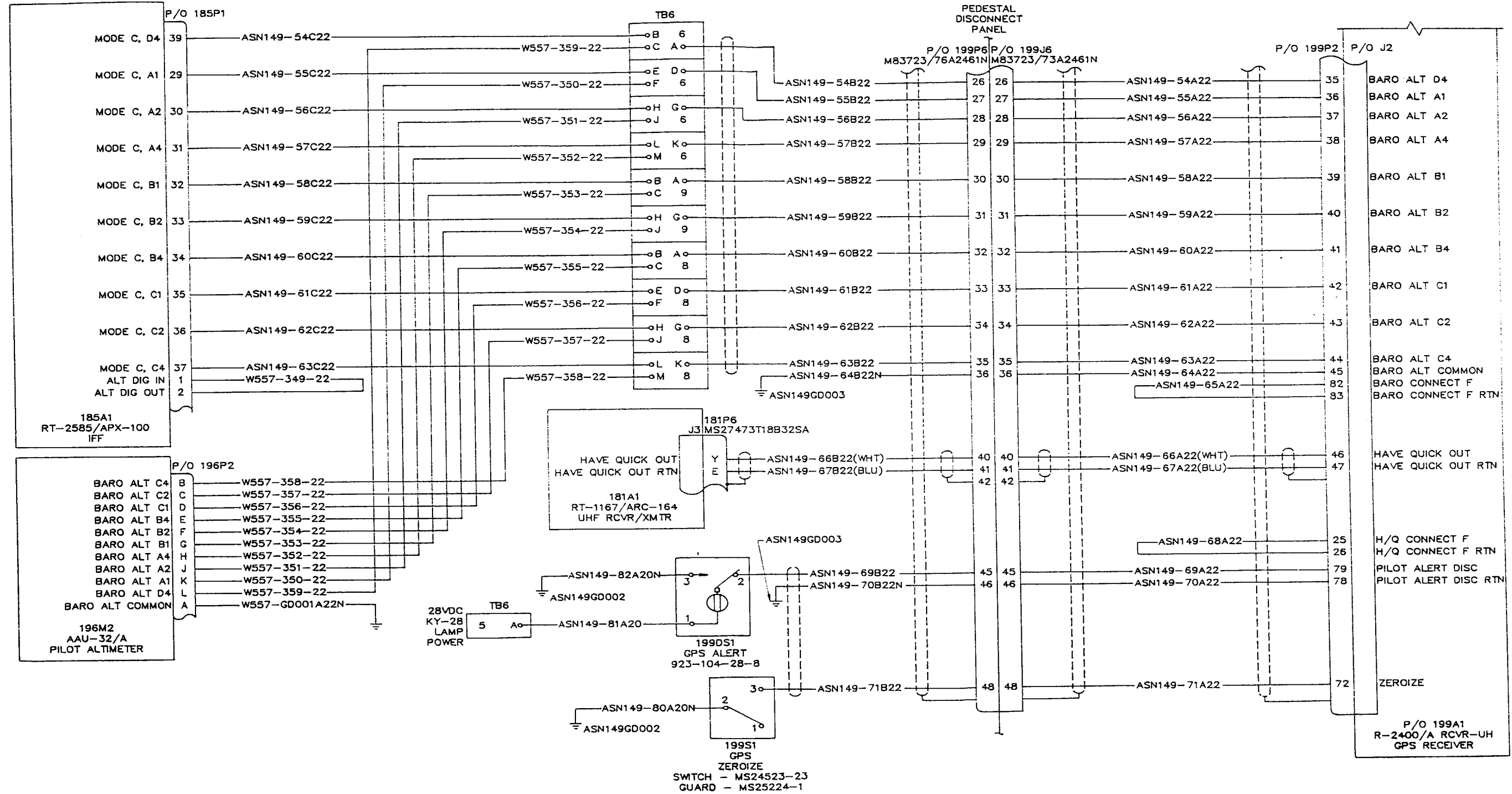

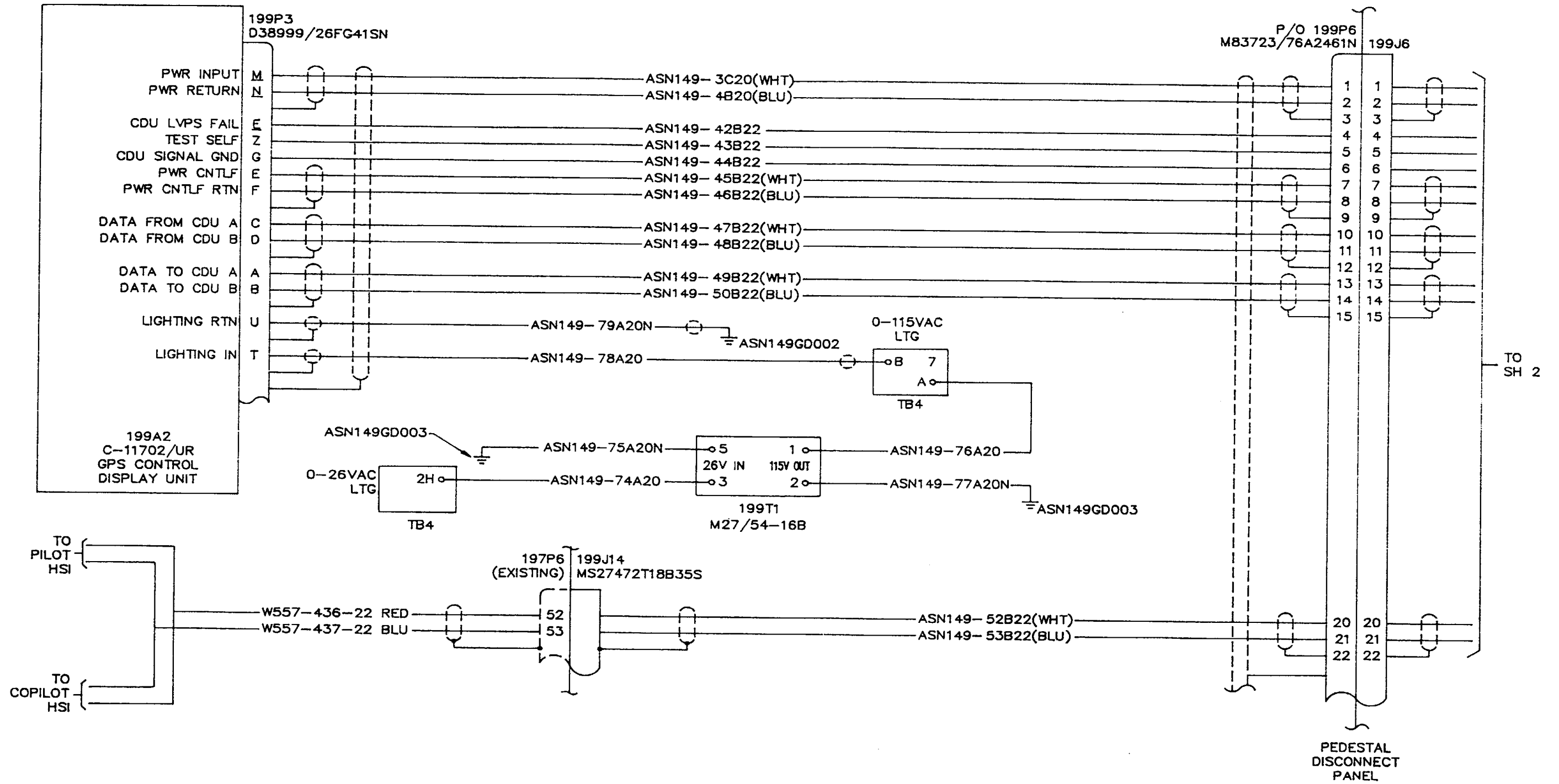

INITIAL SETUP

Applicable Configurations

All

Tools:

Electrical Repairer's Tool Kit,
NSN 5180-00-323-4915

Materials:

None

Personnel Required:

68F10 Aircraft Electrician

References:

TM 55-1520-240-23

Equipment Condition:

TM 55-1520-240-23:
Battery Disconnected
Electrical Power Off
No. 2 Access Door (Tunnel Cover)
Open

TASK	RESULT
1. Check GPS CDU (1).	Loosen Dzus fasteners and check connector of GPS CDU(1). If connector is loose or damaged tighten or replace it as required. If wiring to connector is loose or damaged, tighten, repair, or replace it as required. If display screen is damaged in any way replace CDU (1). If knobs are loose or broken tighten or replace as required. If pushbuttons are damaged replace CDU (1). Reinstall CDU (1) in the canted console tightening the Dzus fasteners.
2. Check GPS Alert Light Indicator (2).	If indicator (2) is loose or damaged tighten or replace as required.
3. Check GPS Zeroize Switch/Cover (3).	If switch or cover (3) is loose or damaged tighten or replace as required. If wiring to switch is loose or broken tighten, repair, or replace as required.
4. Check GPSIDOP SEL Indicator (4).	If indicator lens (4) is damaged replace.
5. Check GPS RCVR and GPS CONT Circuit	If breaker(s) (5) is loose or damaged tighten or Breakers (5). replace as required. If wiring to breaker(s) is loose or broken tighten, repair, or replace as required.
6. Check GPS Radio Receiver R-2400()A (6).	If receiver (6) is loose or damaged tighten or replace as required. If connectors to the receiver are loose or damaged tighten or replace as required. If wiring or cables to receiver are loose or damaged tighten, repair, or replace as required.

TASK	RESULT
7. Check GPS Data Loader Receptacle (7).	If receptacle (7) is loose or damaged tighten or replace as required. If pushbutton is loose or damaged replace Data Loader Receptacle. If the connector to the receptacle is loose or damaged tighten or replace as required. If wiring to the connector is loose or damaged tighten, repair, or replace as required.
8. Check KYK/GPS Fill Connector (J1) (8).	If connector (8) is loose or damaged tighten or replace as required. If wiring to the connector is loose or damaged tighten, repair, or replace as required.
9. Check INIT Load Push Button Switch (9).	If switch (9) is loose or damaged tighten or replace as required. If wiring to the connector is loose or damaged tighten, repair, or replace as required.
10. Check Load Status LED (10).	If LED (10) is loose or damaged tighten or replace as required.
11. Check AE-4 Antenna Amplifier (11).	If amplifier (11) is loose or damaged tighten or replace as required. If connectors to the amplifier are loose or damaged tighten or replace as required. If cables to amplifier J1 and J3 are loose or damaged tighten, repair, or replace as required. If cable to J2 is loose tighten, if damaged replace ONLY, DO NOT REPAIR THIS LOW-LOSS CABLE GOING TO GPS ANTENNA (12).
12. Check GPS Antenna (13).	If antenna (13) is loose or damaged tighten or replace as required. If cable (12) to antenna is loose or broken tighten or replace as required. DO NOT REPAIR THIS CABLE.

FOLLOW-ON MAINTENANCE:
Close No. 2 Access Door (Tunnel Cover)

GO TO NEXT PAGE

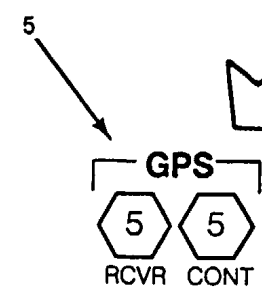
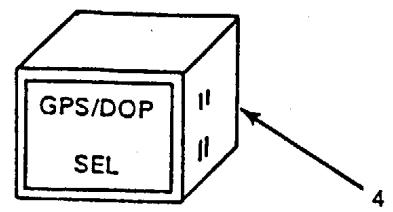
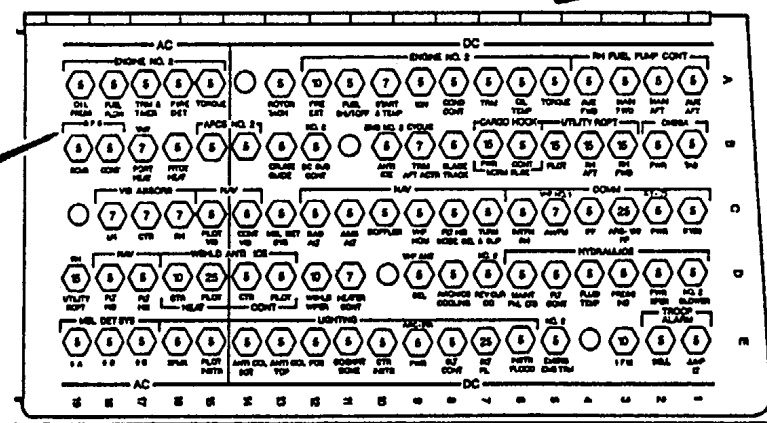
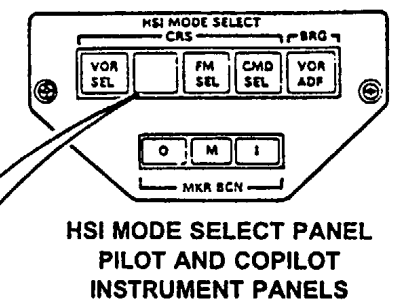
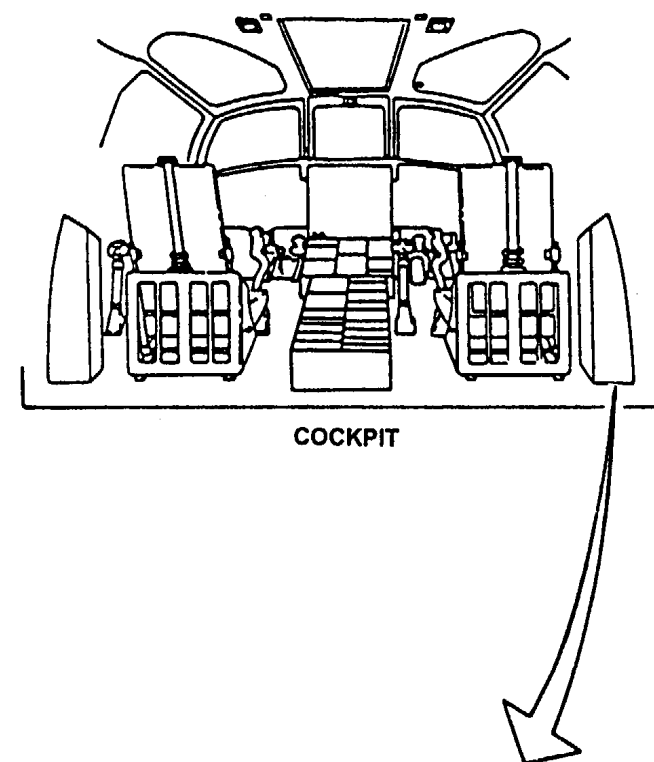
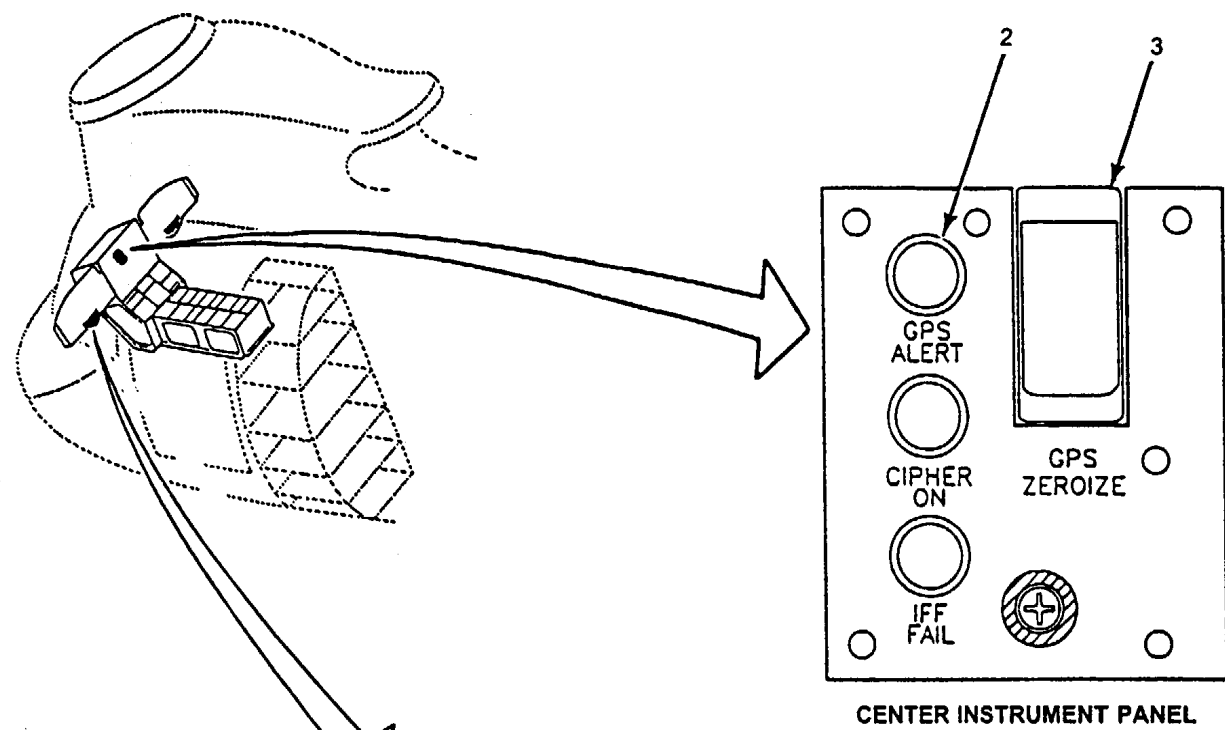

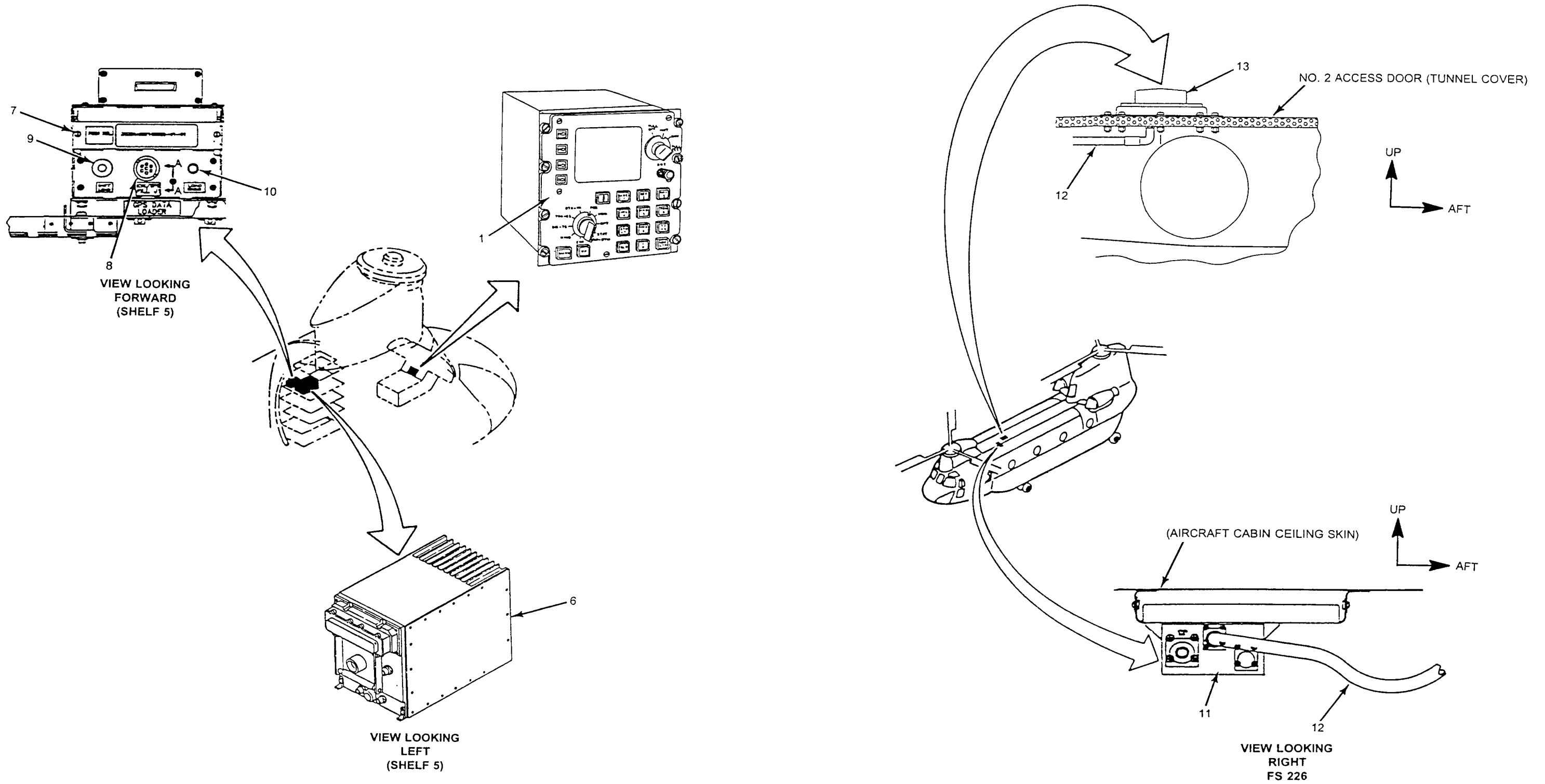

END OF TASK

INITIAL SETUP:

Applicable Configurations:

All

Tools:

Electrical Repairer's Tool Kit,
NSN 5180-00-323-4915

Materials:

None

Personnel Required:

Aircraft Electrician (2)

References:

- TM 11-1520-240-23
- TM 11-5826-308-12
- TM 55-1520-240-23

Equipment Condition:

- TM 55-1520-240-23:
Battery Connected
- Hydraulic Power Off
- Global Positioning System Visual Check Performed
(Task 18-1.2)

TASK	RESULT
CHECK CIRCUIT BREAKERS	
1. Check that the following circuit breakers on No. 2 pdp are closed: GPS RCVR (1) GPS CONT (2)	If any circuit breaker (1 through 2) is open, close it.
2. Start APU. Refer to task 15-1.4.	APU ON capsule shall come on.
CHECK GPS CDU C- 11702/UR	
3. Turn aircraft CTR CSL LTG control (3) clockwise and counterclockwise while checking CDU (4) panel lighting.	CDU (4) panel light shall vary with the changing setting of the aircraft dimmer control (3). If CDU (4) panel light is not visible or intensity level does not vary with aircraft dimmer control (3) refer to TM 55-1520-240-T-2, Chapter 9.
4. Turn the CDU (4) BRT control (5) clockwise and counterclockwise while checking the CDU data display screen (6) intensity level.	CDU data display screen (6) intensity level shall vary with the changing setting of the CDU BRT control (5). If no display appears or intensity level does not vary, go to task 18-1.4.
5. Turn CDU Mode Switch (7) to TEST.	After a 30-second warm-up the CDU data display (6) shall display data. If failure data is displayed instead of TEST IN PROG, go to task 18-1.6. After the test is completed TEST COMPLETE shall be displayed on line 1 and TEST OK shall be displayed on line 2 of the CDU data display (6). If failure data is displayed, go to task 18-1.6.
CHECK GPS RECEIVER R-2400()/A	
6. Check the time totalizing meter (8) on front panel of GPS receiver (9).	The pointer on the left side of the time totalizing meter window shall have an up/down movement. If no up/down movement, go to task 18-1.5.

TASK	RESULT
CHECK GPS SYSTEM OPERATION	
NOTE	
Continue with the following checks only after the Start-up procedures given in TM 11-5826-30812 or local directives have been completed (for a COLD start) and the GPS System is tracking 4 satellites. The Mode switch (7) shall be positioned on NAV.	
7. With 4 satellites being tracked and the Figure of Merit (FM) being 5 or less, set the Data switch (10) on the CDU (4) to STAT. Slew (11) down to page 2 and write down the Almanac Age displayed on line 2 (ALM followed by numbers). Information will be needed later.	If 4 satellites cannot be tracked, go to task 18-1.7.
8. Depress the GPS Alert Indicator (18).	The GPS Alert Indicator (18) shall illuminate. If indicator does not illuminate, go to task 18-1.10. The GPS Alert Indicator (18) shall illuminate. If indicator does not illuminate, go to task 18-1.10.
9. With the Data switch (10) of the CDU set to MSN, slew (11) down to page 2. Press line select key two (12) until THRESH: ENRT is displayed. Enter a figure of merit on display (6) line three at least one level below the existing GPS system figure of merit (FM) displayed on line 1.	The SEL indication at the lower half of each GPS/DOP (13) lens shall be illuminated. If SEL not illuminated, go to task 18-1.11.
10. Depress the GPS/DOP lenses (13) on each of the two HSI Mode Select Panels (14) (one each in pilot and copilot instrument panels).	The number one needle (20) of each HSI indicator (25) shall swing to show the bearing to the station with the course deviation bar (21) centered. The Range (22) and Course (23) readouts shall also be accurate. If the number one needle (20) does not swing to show bearing to the station or the Range (22) and Course (23) readouts are not accurate, go to task 18-1.11.
11. Set the Data switch (10) of the CDU set to VARDTM. Enter at least one known waypoint. Set the Data switch (10) to POS and call up the waypoint previously entered.	Successful loading of keys shall be indicated by the flashing of the aircraft's LOAD STATUS indicator lamp (24) within approximately 5 seconds of pressing the aircraft's INIT LOAD switch. If lamp (24) does not flash, go to task 18-1.9. Observe the GPS CDU data display (6). If an error message is present, go to task 18-1.6.
12. Connect a KYK-13 fill device to the KYK/GPS Fill J1 connector (15). Set the GPS CDU Data switch (10) to STAT. Set the fill device Address Select switch to desired setting and the Mode switch to ON. Press and release the aircraft's INIT LOAD switch (16).	

13. Set the GPS CDU Data switch (10) to STAT. Lift switch guard and toggle the Zeroize switch (17).

14. Set the GPS CDU DATA switch (10) to STAT. Insert a Data Loader Module which contains almanac information into the Data Loader Receptacle (19) located on shelf five of the cabin avionics/electronic compartment. Leave in for at least 20 seconds, then remove Data Loader Module.

15. With the GPS CDU Data switch (10) still at STAT, slew (11) down to page 2 and compare the Almanac Age located on display (6) line 2 with the age recorded earlier in step 7.

16. Turn the GPS CDU Mode switch (7) to OFF. Leave OFF for a few minutes then turn back ON with the Mode switch (7) in the NAV position.

17. Stop APU. Refer to task 15-1.4.

The CDU data display (6), line 2 shall display ZEROED. If ZERO FAIL is displayed, go to task 181.12.

No error messages shall be displayed on the CDU data display (6). If an error message is displayed, go to task 18-1.6.

The two values shall be different if the Almanac stored in the Data Loader Module has been successfully loaded into the GPS system. If the Almanac Age is the same as before loading data with the Data Module, go to task 18-1.8.

After warmup and test completion, GNAV shall appear on CDU data display (6) line 1. This means that the previously loaded almanac has been stored by the GPS receiver (9). If COLD appears on CDU data display (6) line 1 instead, go to task 18-1.13.

FOLLOW-ON MAINTENANCE:

- TM 55-1520-240-23:
- Battery Disconnected
- Electrical Power Off

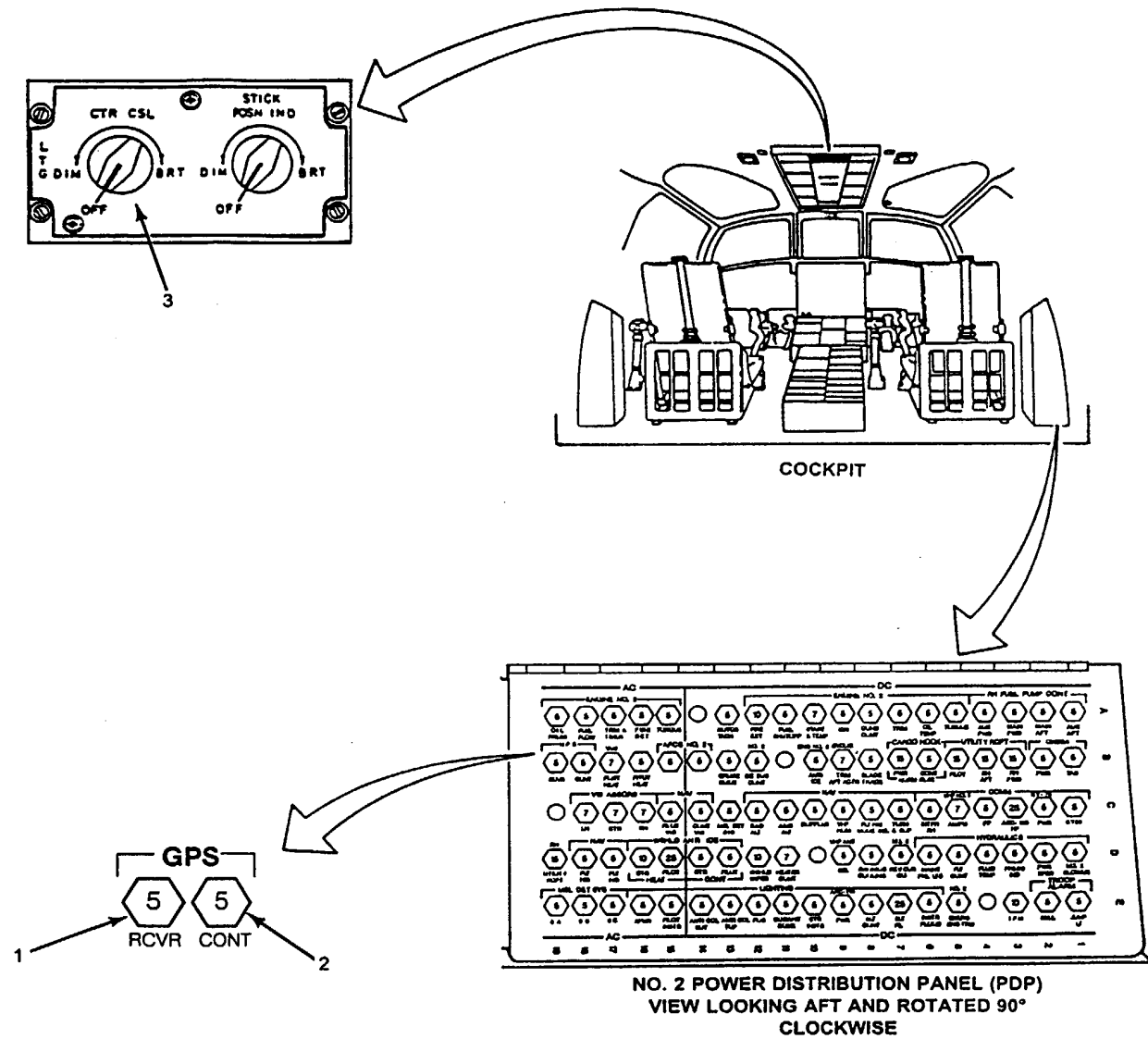

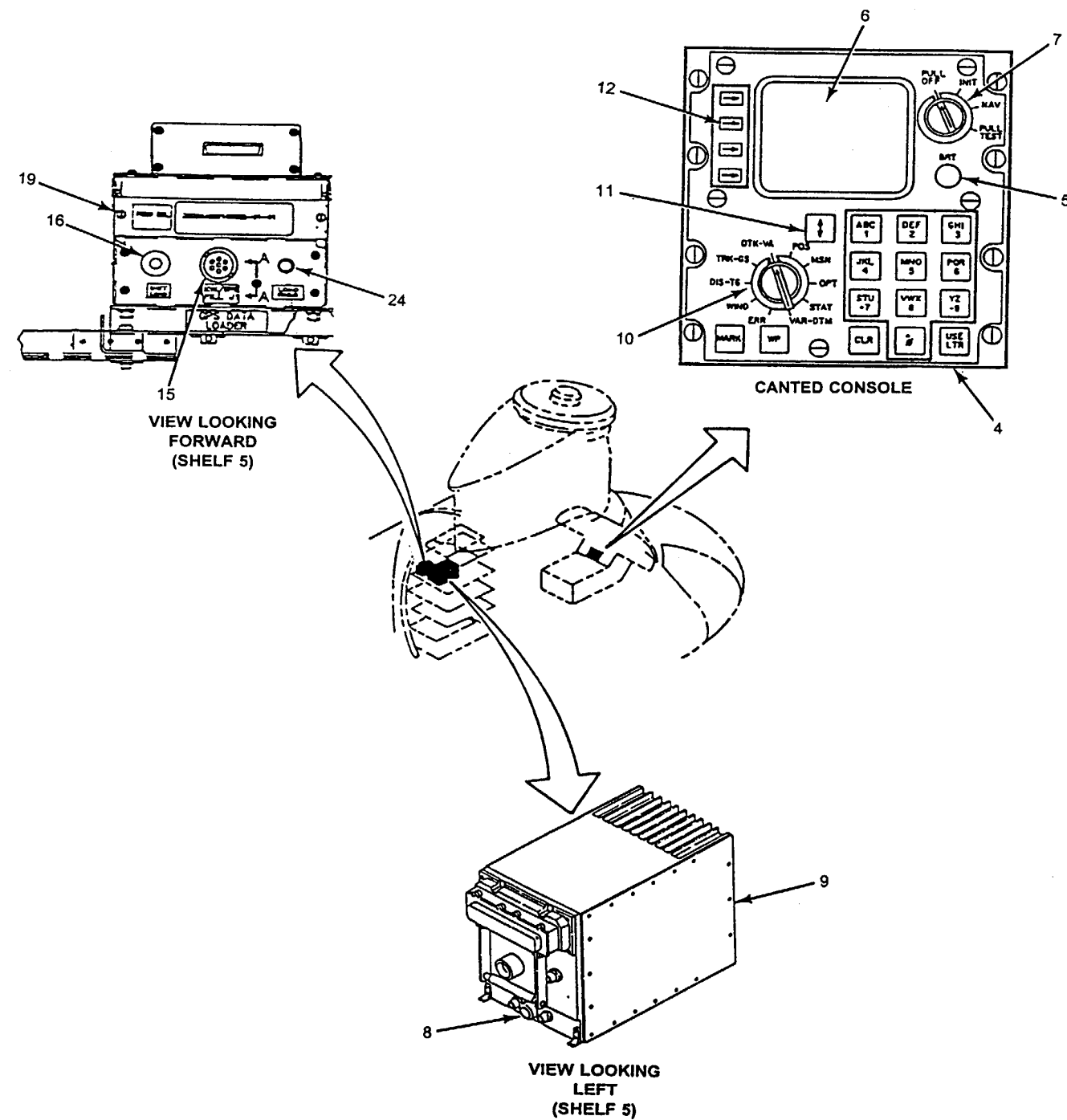
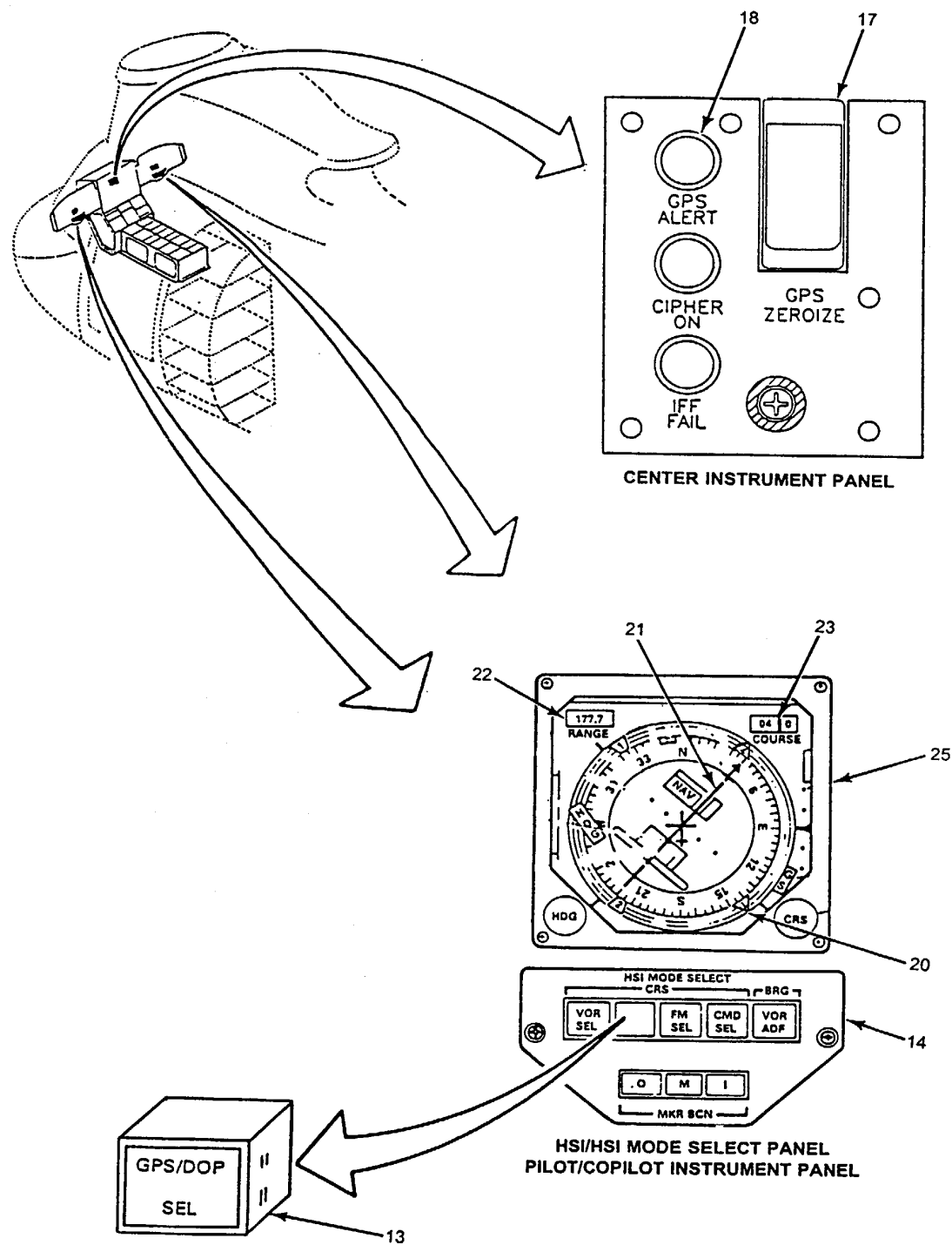

FAULT ISOLATION PROCEDURE

INITIAL SETUP

Applicable Configurations:
All

References:

TM 11-5826-308-12
TM 55-1520-240-23

Tools:

Electrical Repairer's Tool Kit,
NSN 5180-00-323-4915
Multimeter, AN/USM-223,
NSN 6625-00-999-7465

Equipment Condition:

TM 55-1520-240-23:
Battery Connected
Electrical Power On
Hydraulic Power Off

Materials:

None

Personnel Required:

Aircraft Electrician

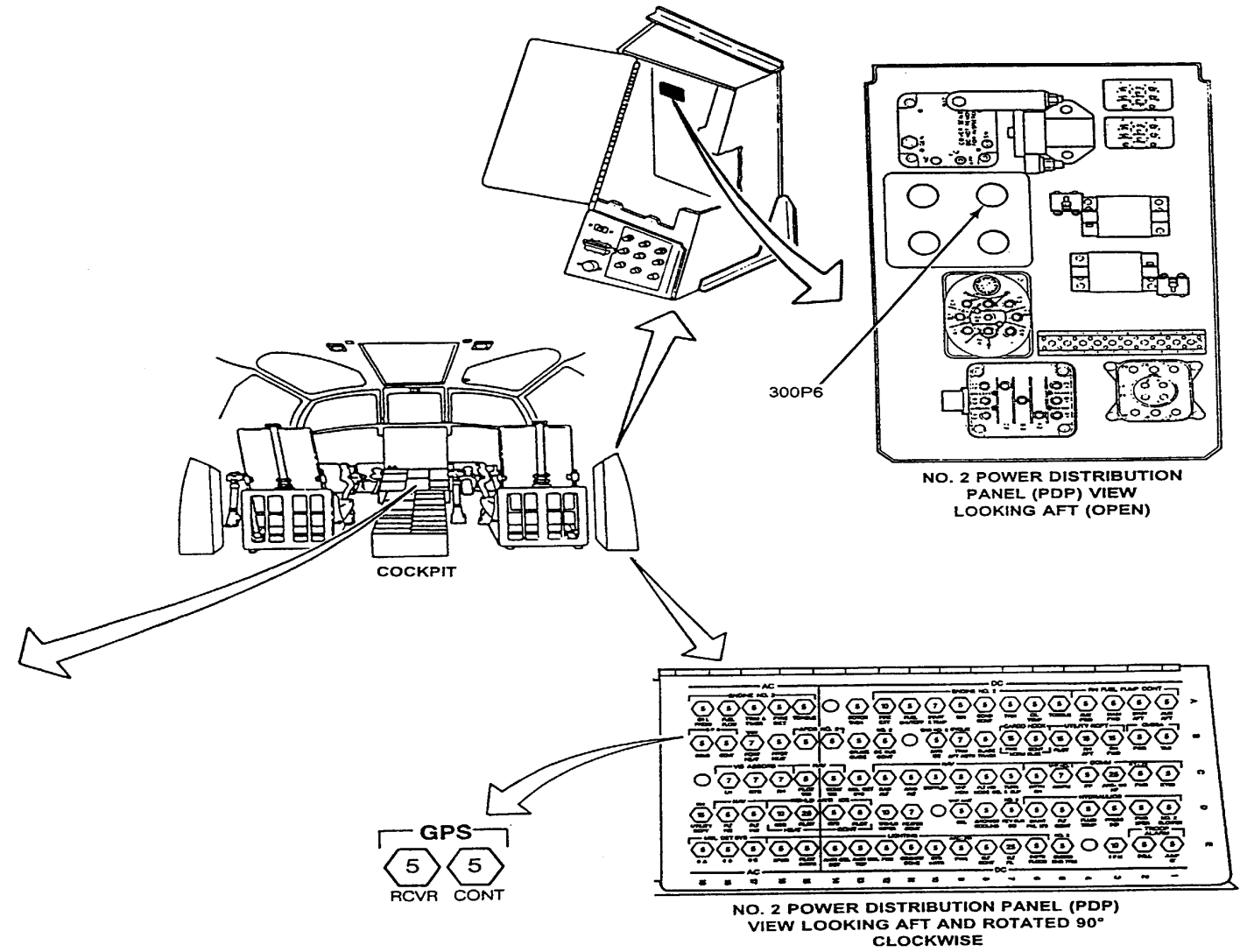
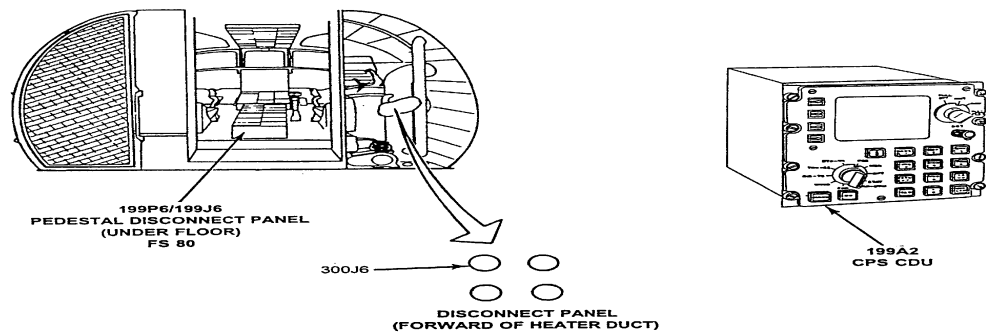

18-1.4 GPS DISPLAY DOES NOT TURN ON OR INTENSITY DOES NOT VARY WITH CDU BRT CONTROL (Continued)

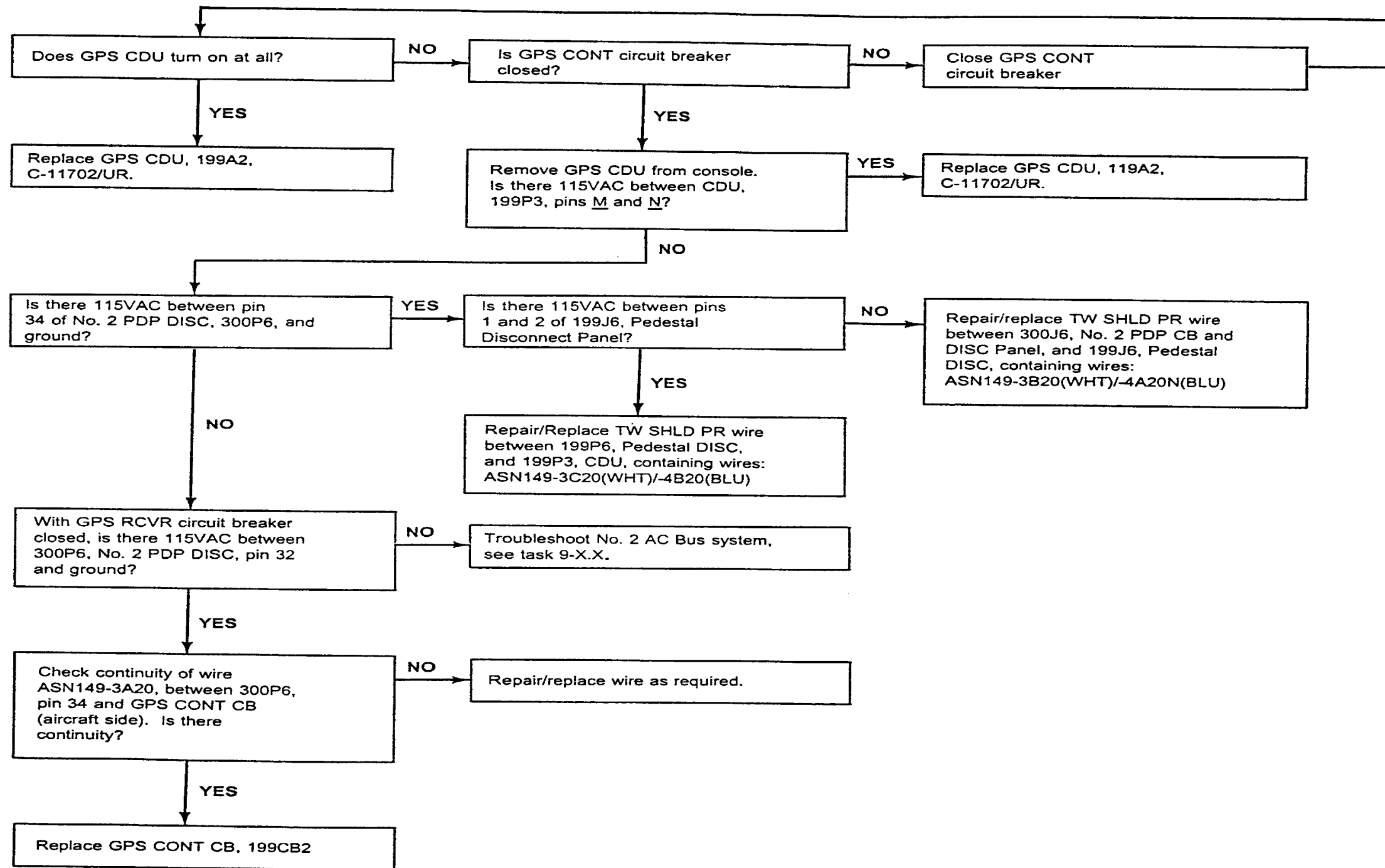

FA UL T ISOLA TION PROCEDURE

INITIAL SETUP

Applicable Configurations:
All

References:
TM 11-5826-308-12
TM 55-1520-240-23

Tools:
Electrical Repairer's Tool Kit,
NSN 5180-00-323-4915

Equipment Condition:
TM 55-1520-240-23:
Battery Connected
Electrical Power On
Hydraulic Power Off

Materials:
None

Personnel Required:
Aircraft Electrician

Replace GPS RCVR R-2400()/A.

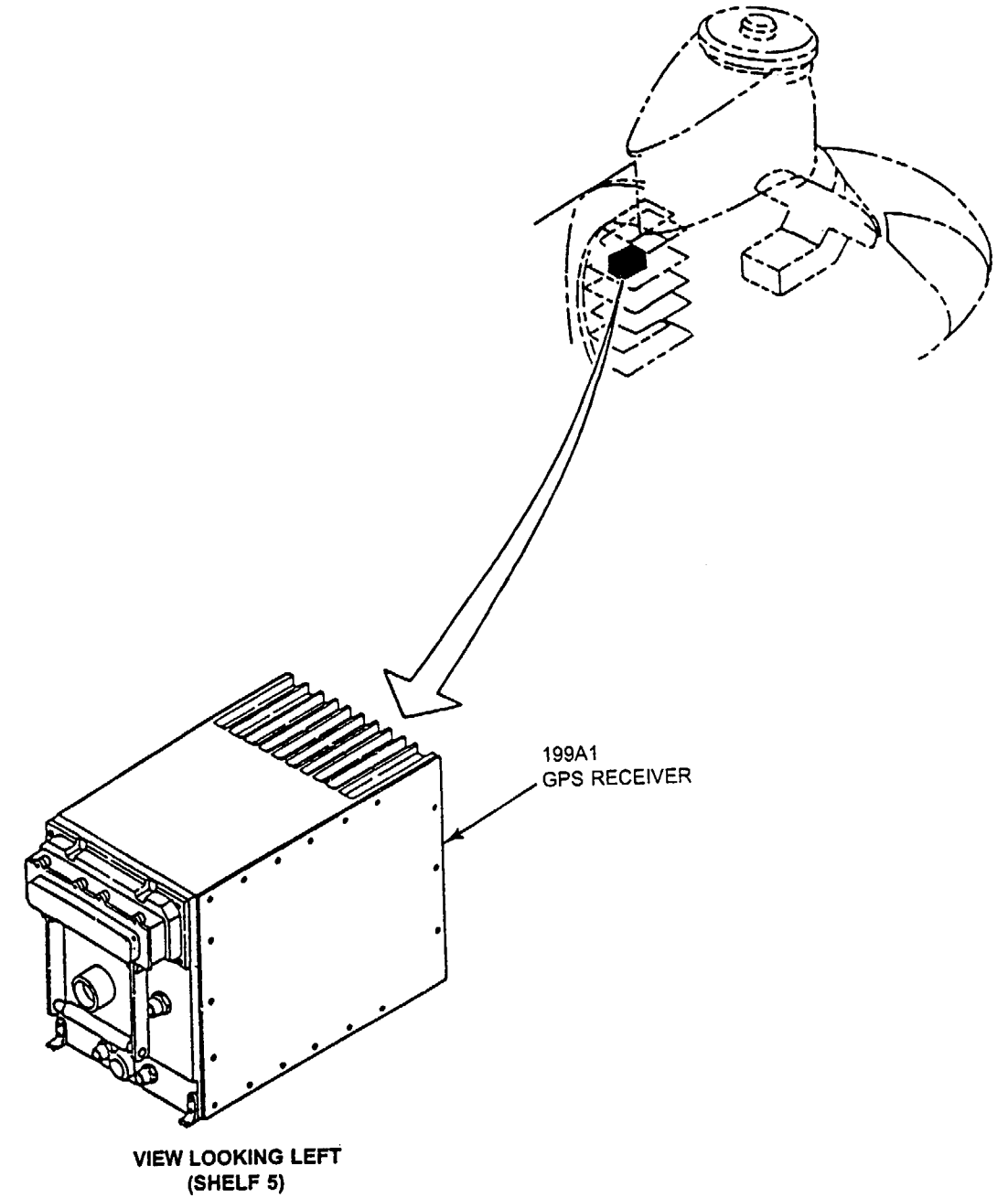

PAGE INTENTIONALLY LEFT BLANK

Change 18 18-21

FA UL ISOLA TION PROCEDURE

INITIAL SETUP

Applicable Configurations:

All

References:

TM 11-5826-308-12

TM 55-1520-240-23

Tools:

Electrical Repairer's Tool Kit,
NSN 5180-00-323-4915

Equipment Condition:

TM 55-1520-240-23:

Battery Connected

Electrical Power On

Hydraulic Power Off

Materials:

None

Personnel Required:

Aircraft Electrician

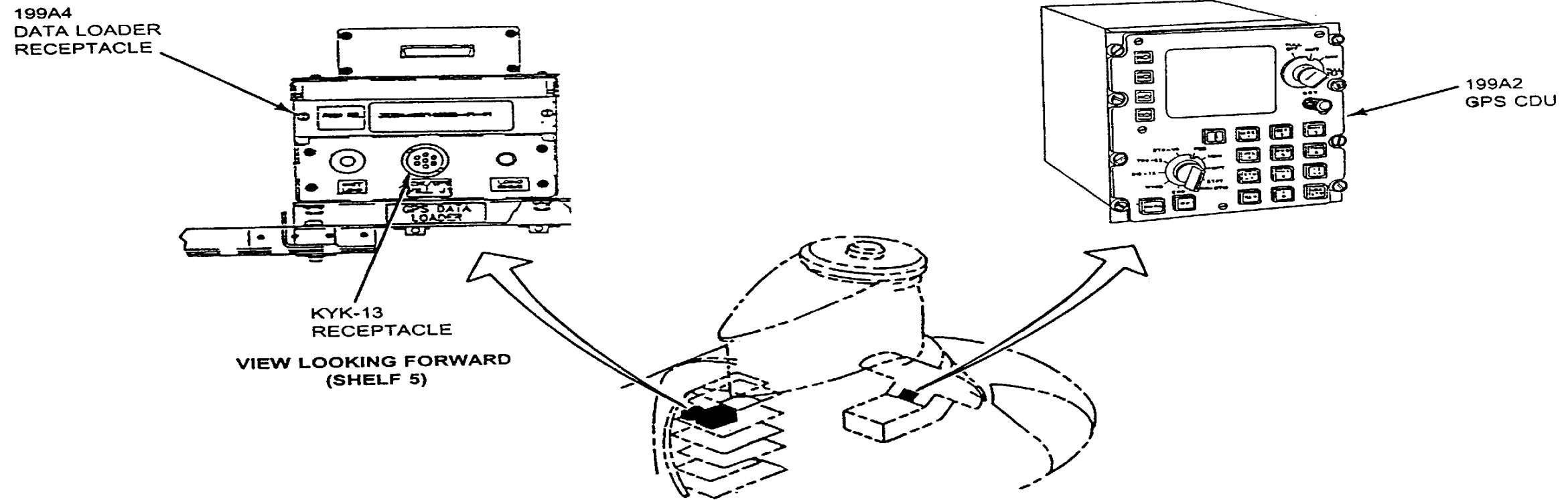

**GPS CDU DISPLAYS "FAIL" MESSAGE WHEN ATTEMPTING TO LOAD KEYS
USING DATA LOADER MODULE OR KYK-13 FILL DEVICE**

Note Error Message and Report
to Organizational Maintenance

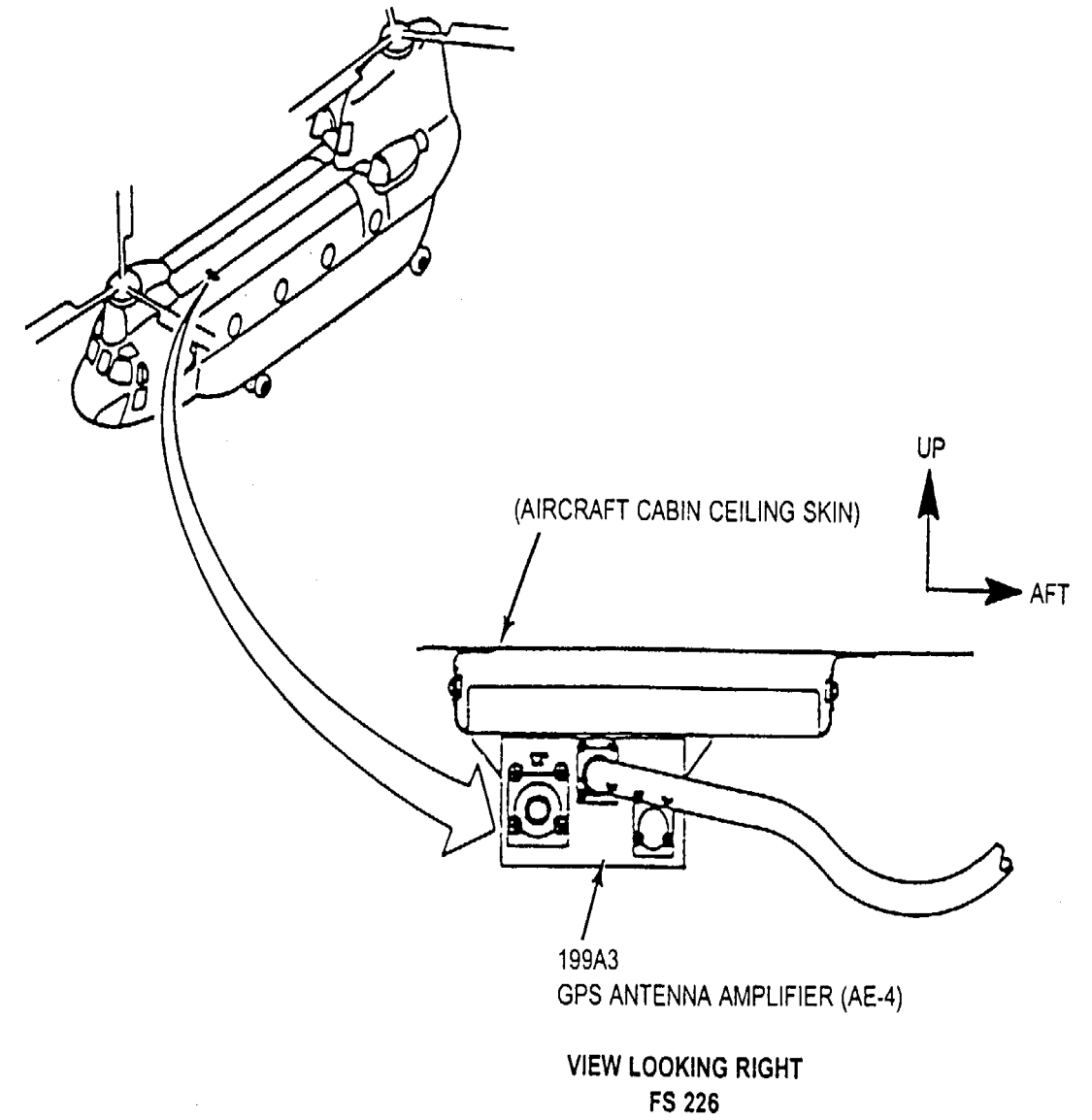
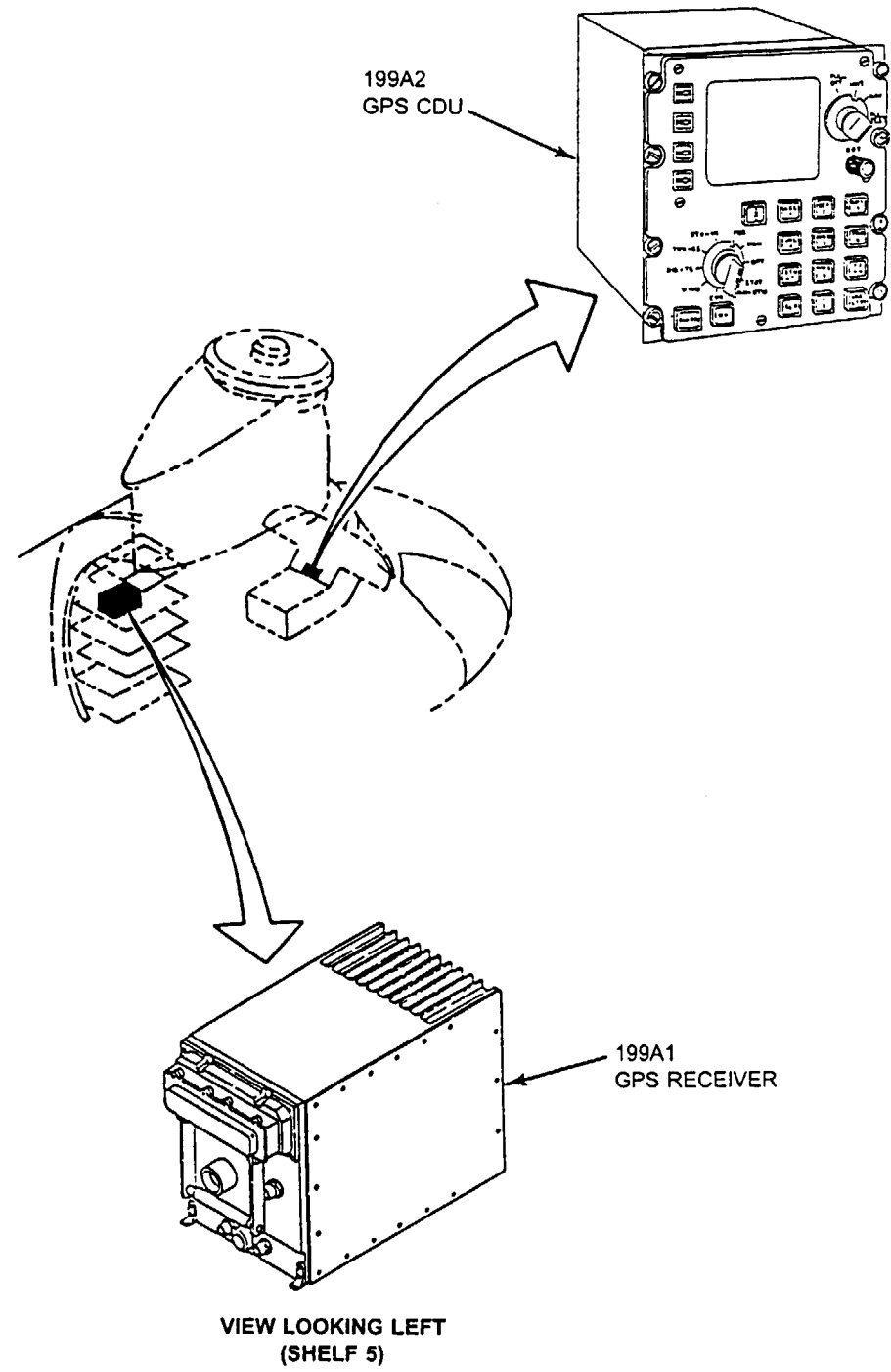

GPS CDU DISPLAYS "FAIL" MESSAGE DURING TEST MODE

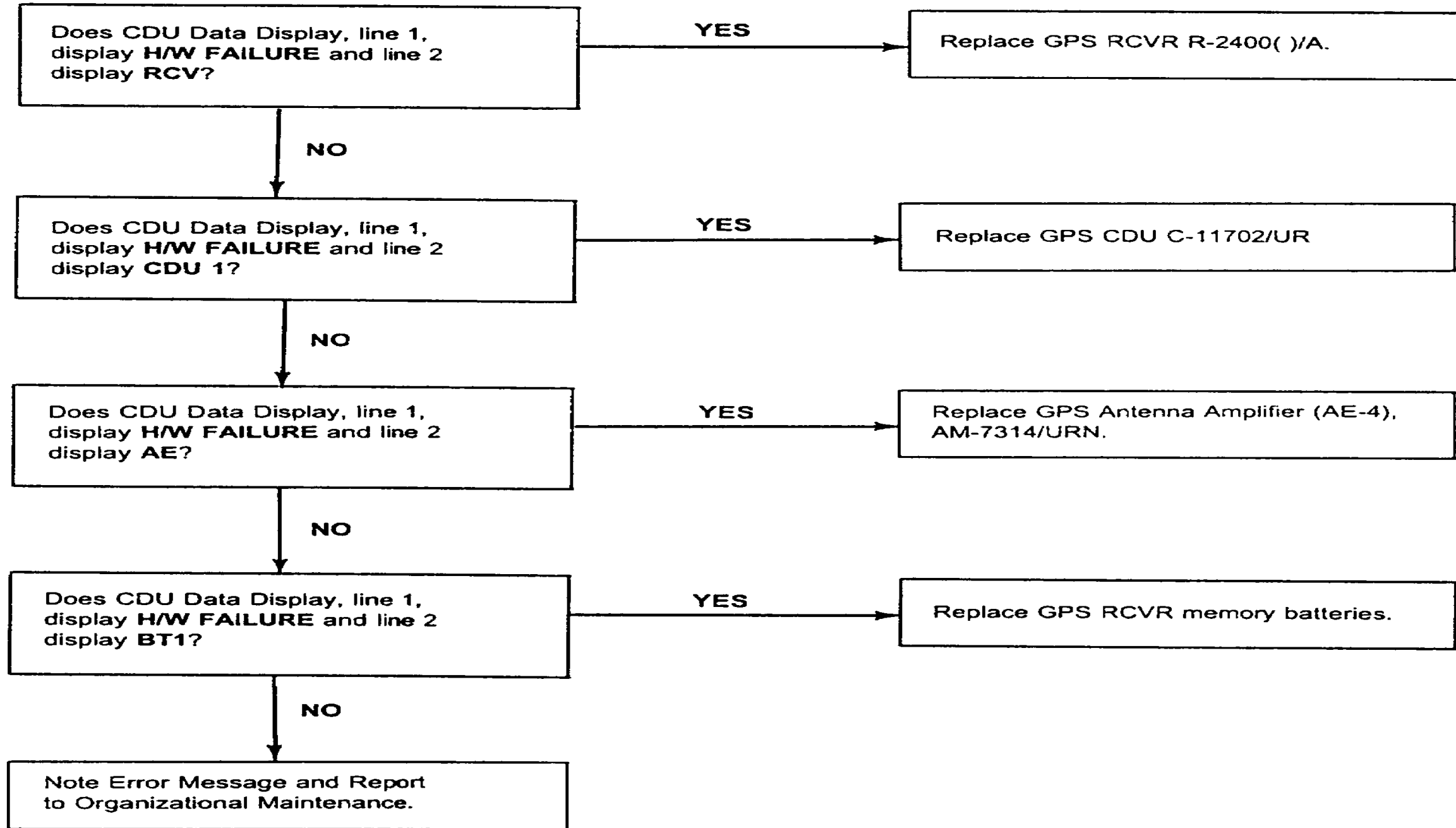

FAULT ISOLATION PROCEDURE

INITIAL SETUP

Applicable Configurations:
All

References:
TM 11-5826-308-12
TM 55-1520-240-23

Tools:
Electrical Repairer's Tool Kit,
NSN 5180-00-323-4915
Multimeter, AN/USM-223,
NSN 6625-00-999-7465

Equipment Condition:
TM 55-1520-240-23:
Battery Connected
Electrical Power On
Hydraulic Power Off

Materials:
None

Personnel Required:
Aircraft Electrician

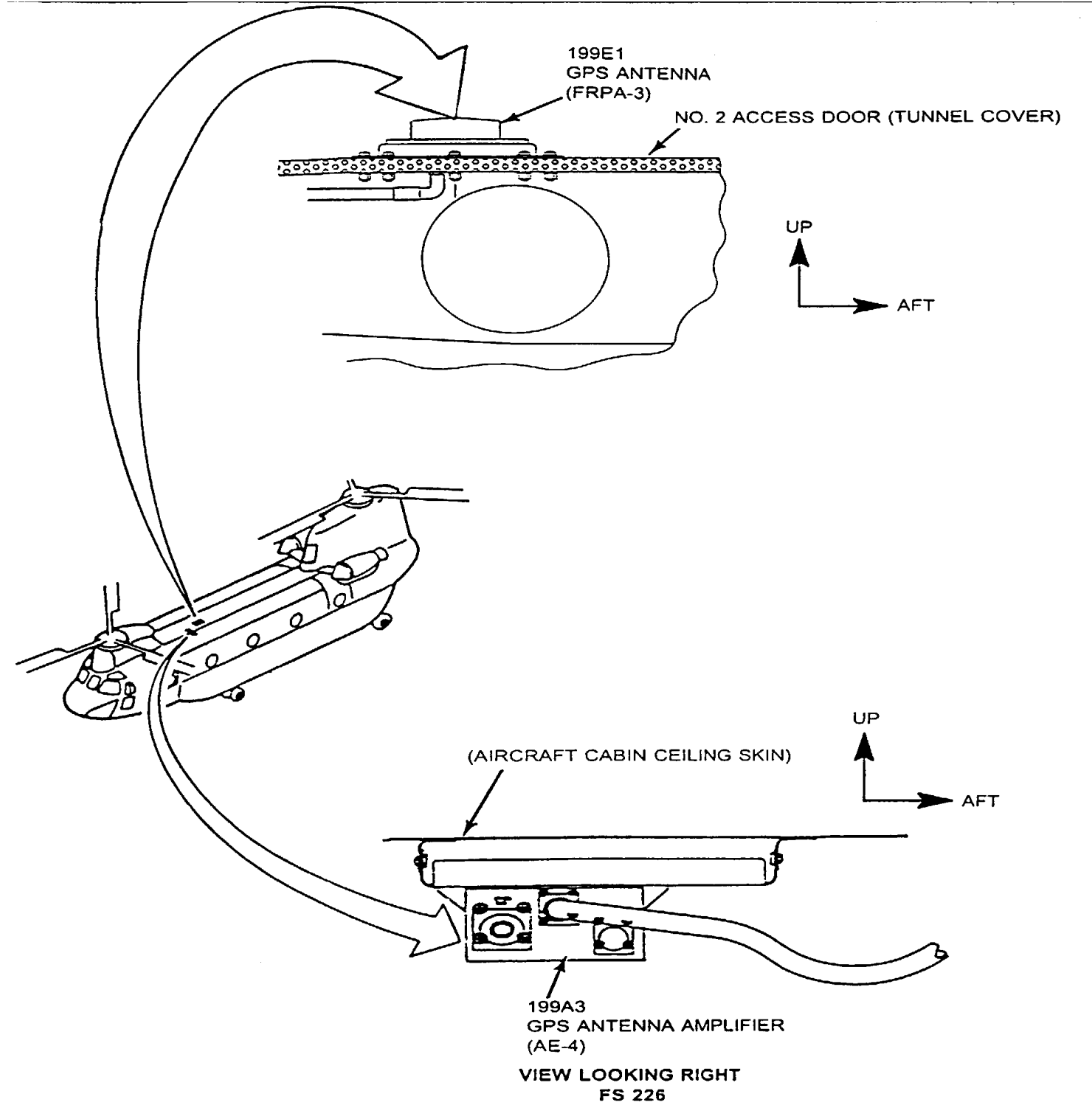
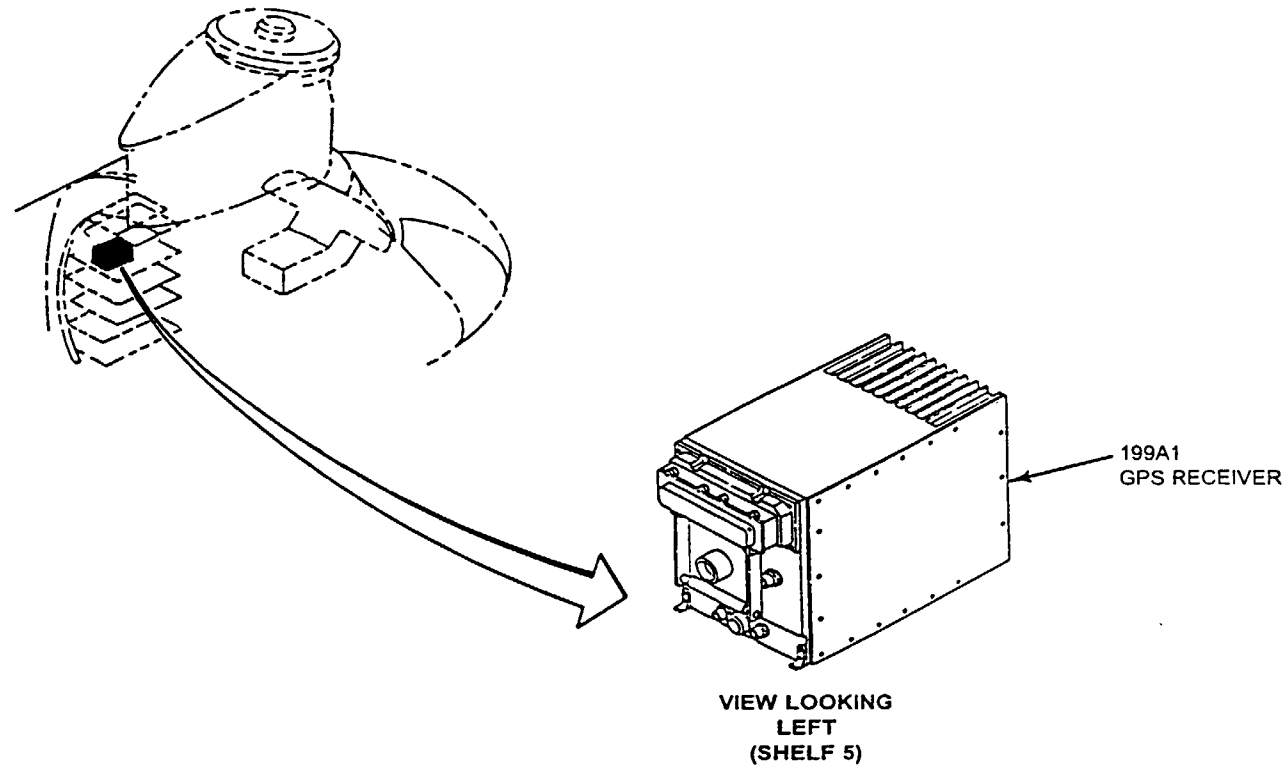

18-1.7 LESS THAN 4 SATELLITES CAN BE TRACKED AND ESTIMATED POSITION ERROR (EPE) IS NOT WITHIN LIMITS OF GPS SYSTEM'S FIGURE OF MERIT (FM)
(Continued)

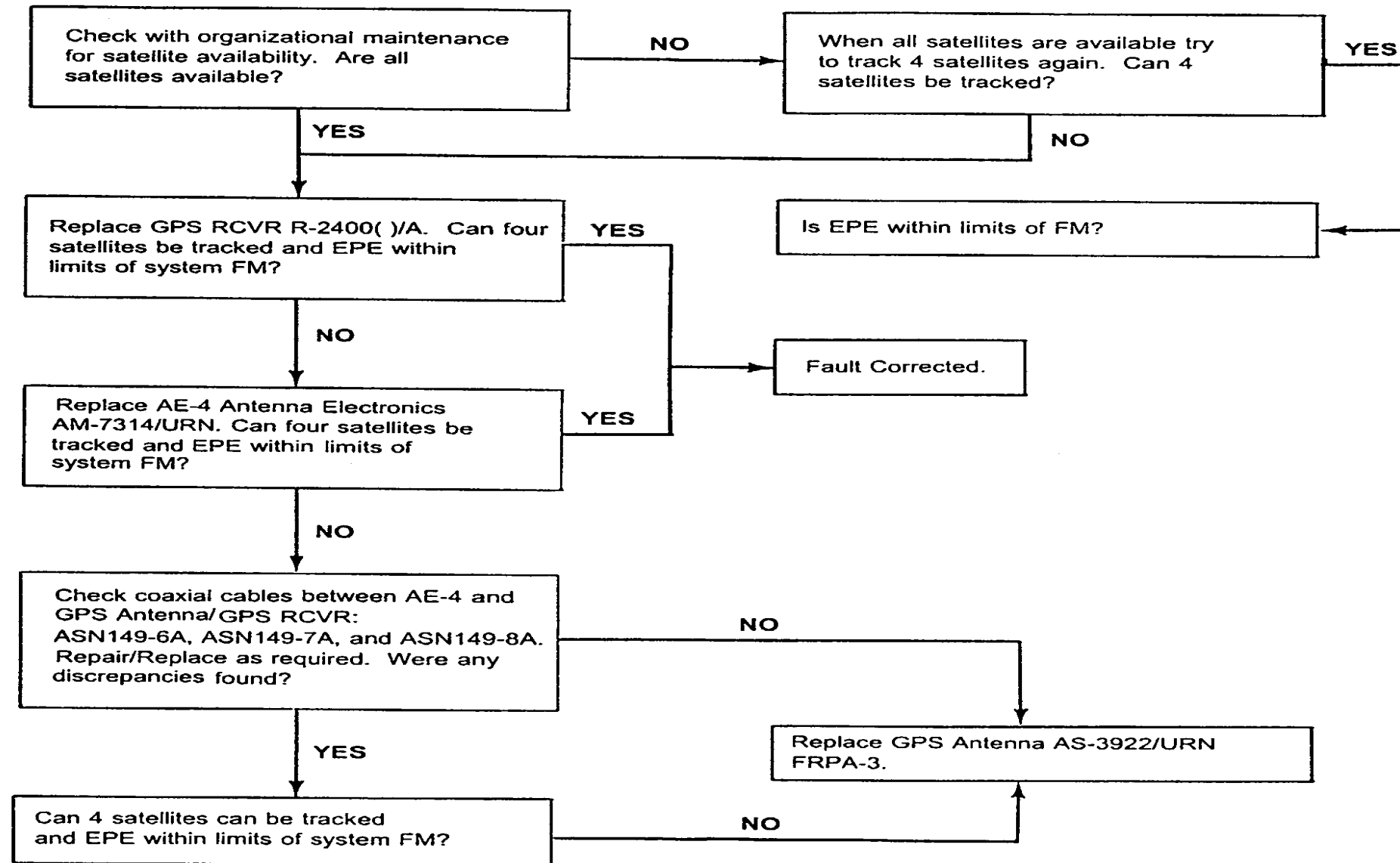

FAULT ISOLATION PROCEDURE

INITIAL SETUP

Applicable Configurations:
All

References:
TM 11-5826-308-12
TM 55-1520-240-23

Tools:
Electrical Repairer's Tool Kit,
NSN 5180-00-323-4915
Multimeter, AN/USM-223,
NSN 6625-00-999-7465

Equipment Condition:
TM 55-1520-240-23:
Battery Connected
Electrical Power On
Hydraulic Power Off

Materials:
None

Personnel Required:
Aircraft Electrician

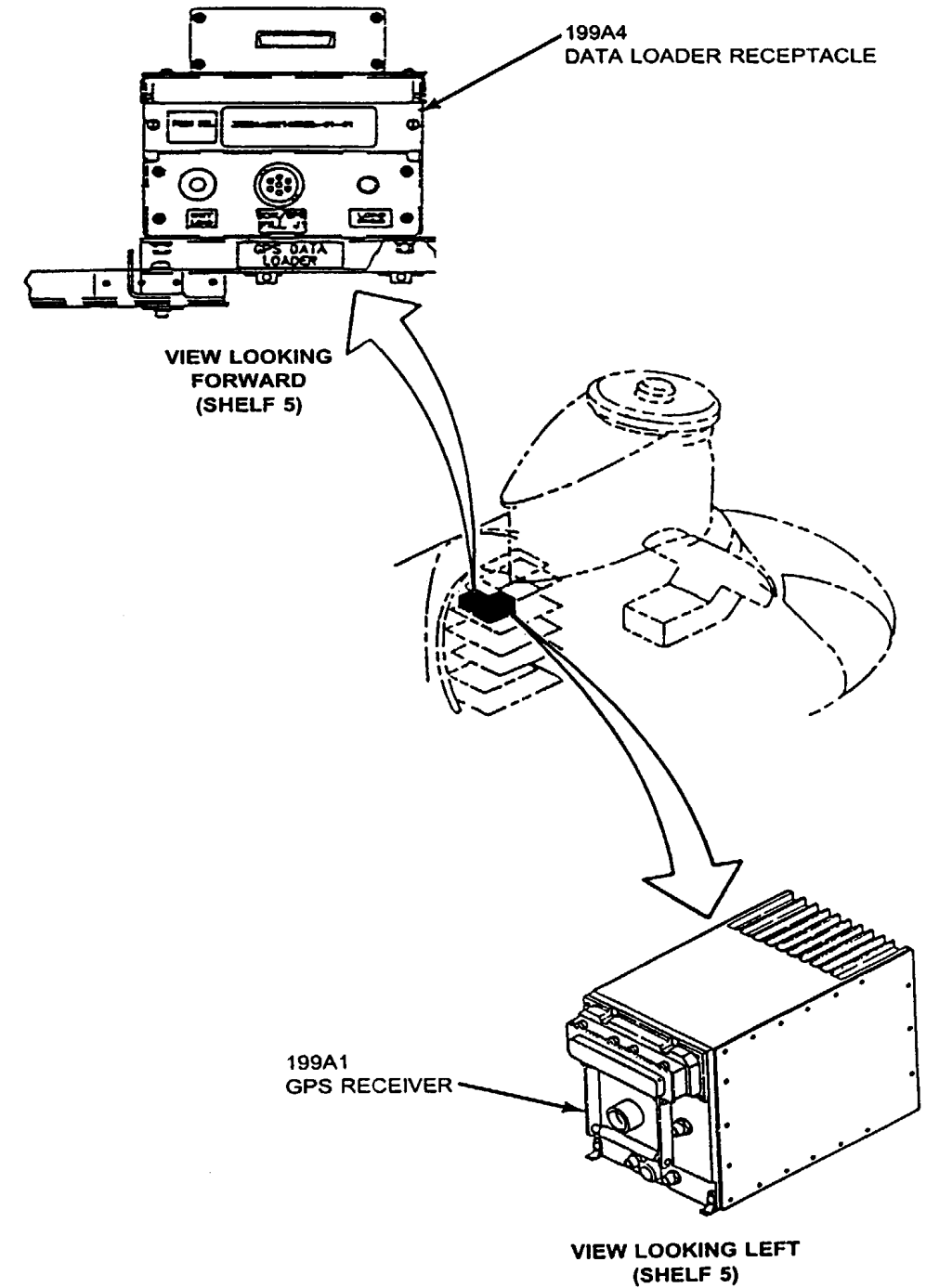
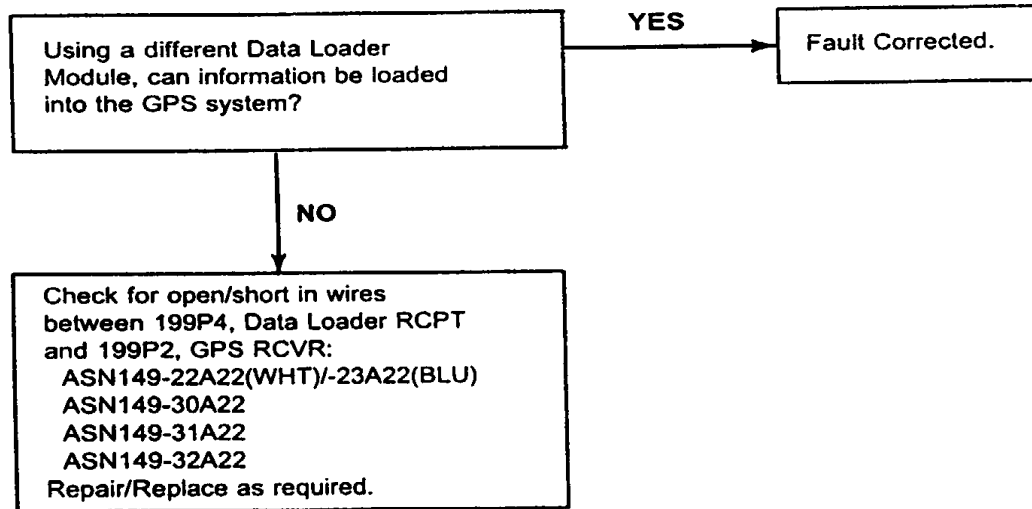

PAGE INTENTIONALLY LEFT BLANK

FAULT ISOLATION PROCEDURE

INITIAL SETUP

Applicable Configurations:

All

References:

TM 11-5826-308-12

TM 55-1520-240-23

Tools:

Electrical Repairer's Tool Kit,
NSN 51 80-00-323-4915
Multimeter, AN/USM-223,
NSN 6625-00-999-7465

Equipment Condition:
TM 55-1520-240-23:
Battery Connected
Electrical Power On
Hydraulic Power Off

Materials:

None

Personnel Required:

Aircraft Electrician

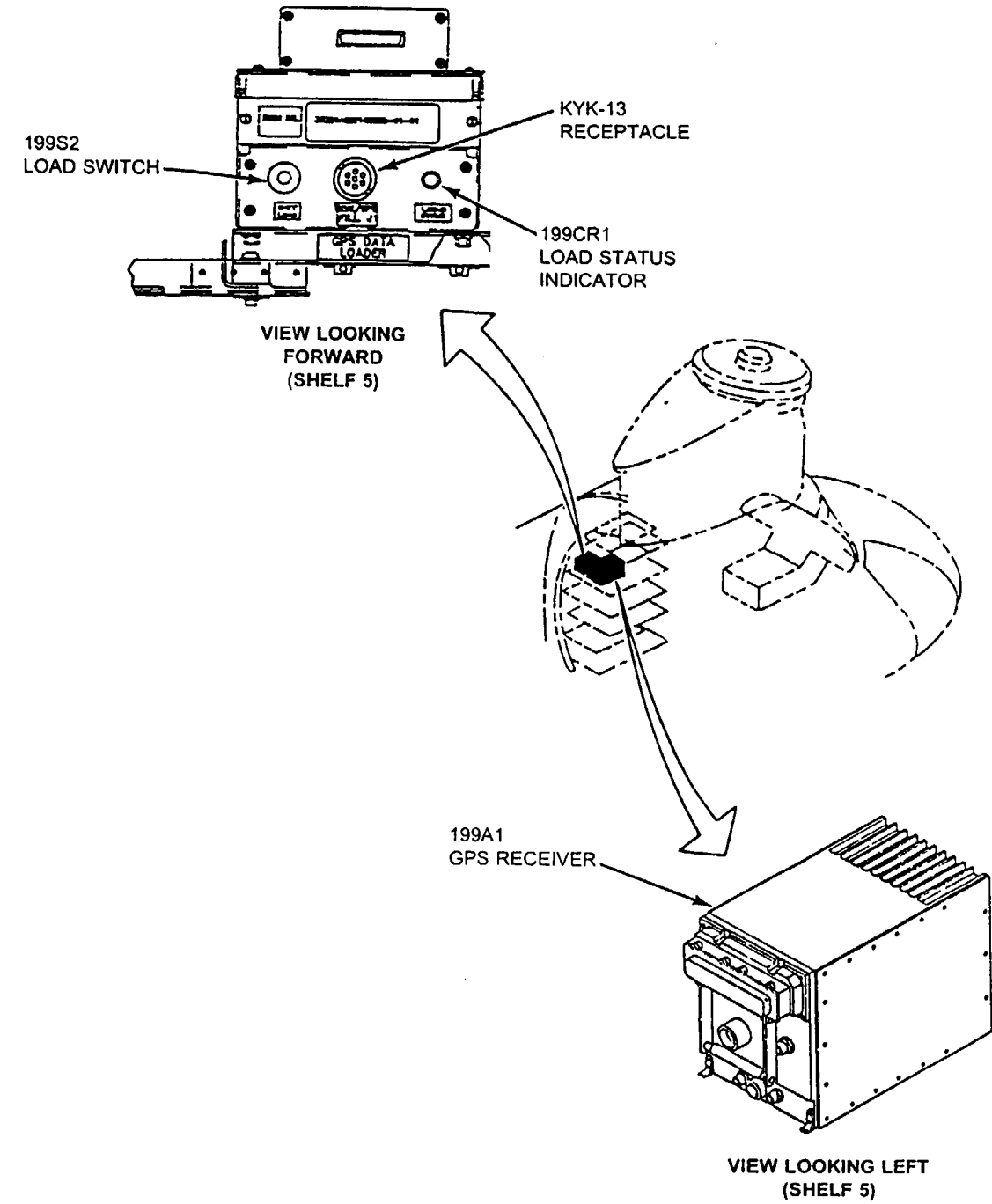

KYK-13 KEYS CANNOT BE LOADED INTO THE GPS SYSTEM

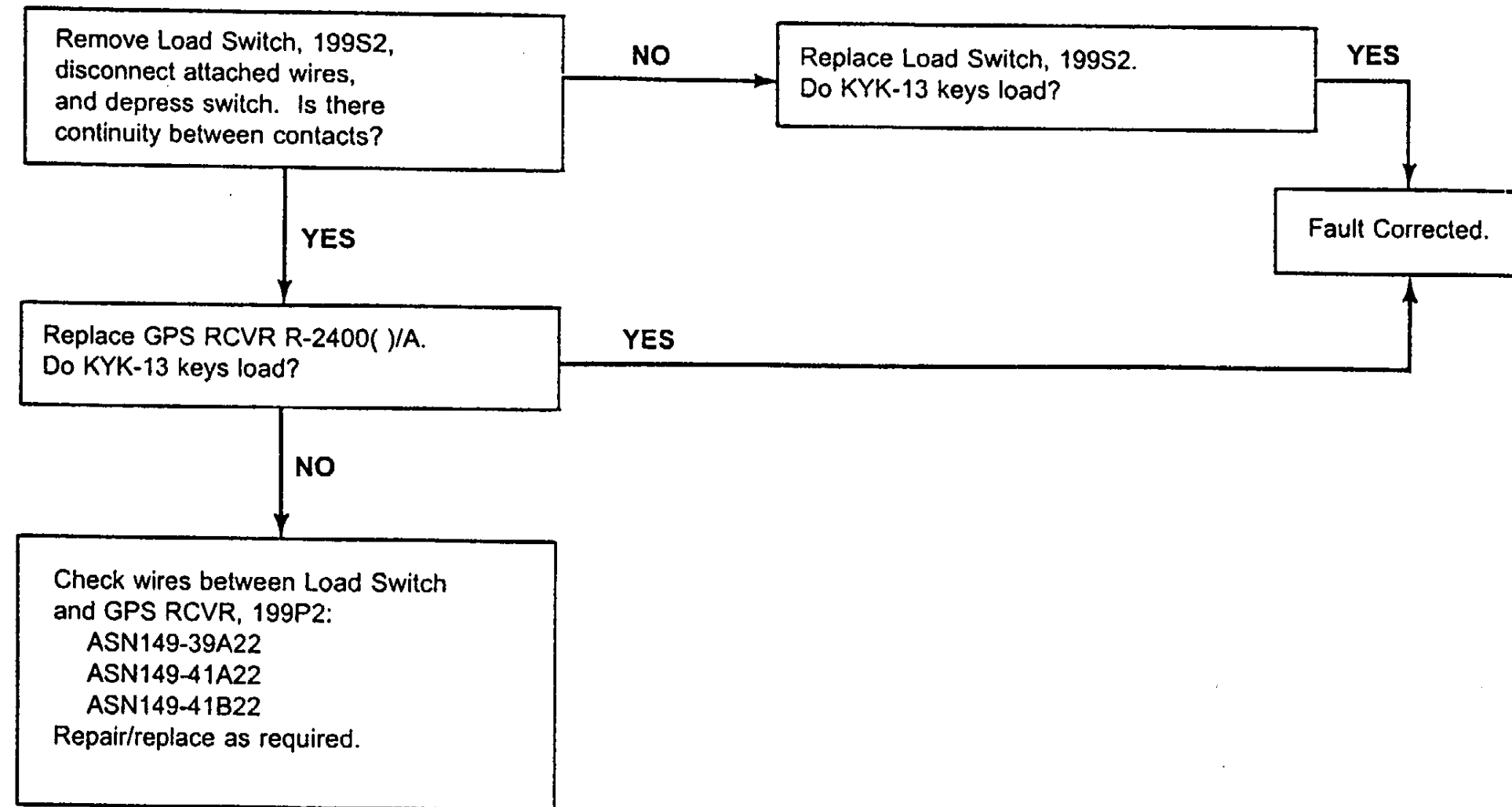

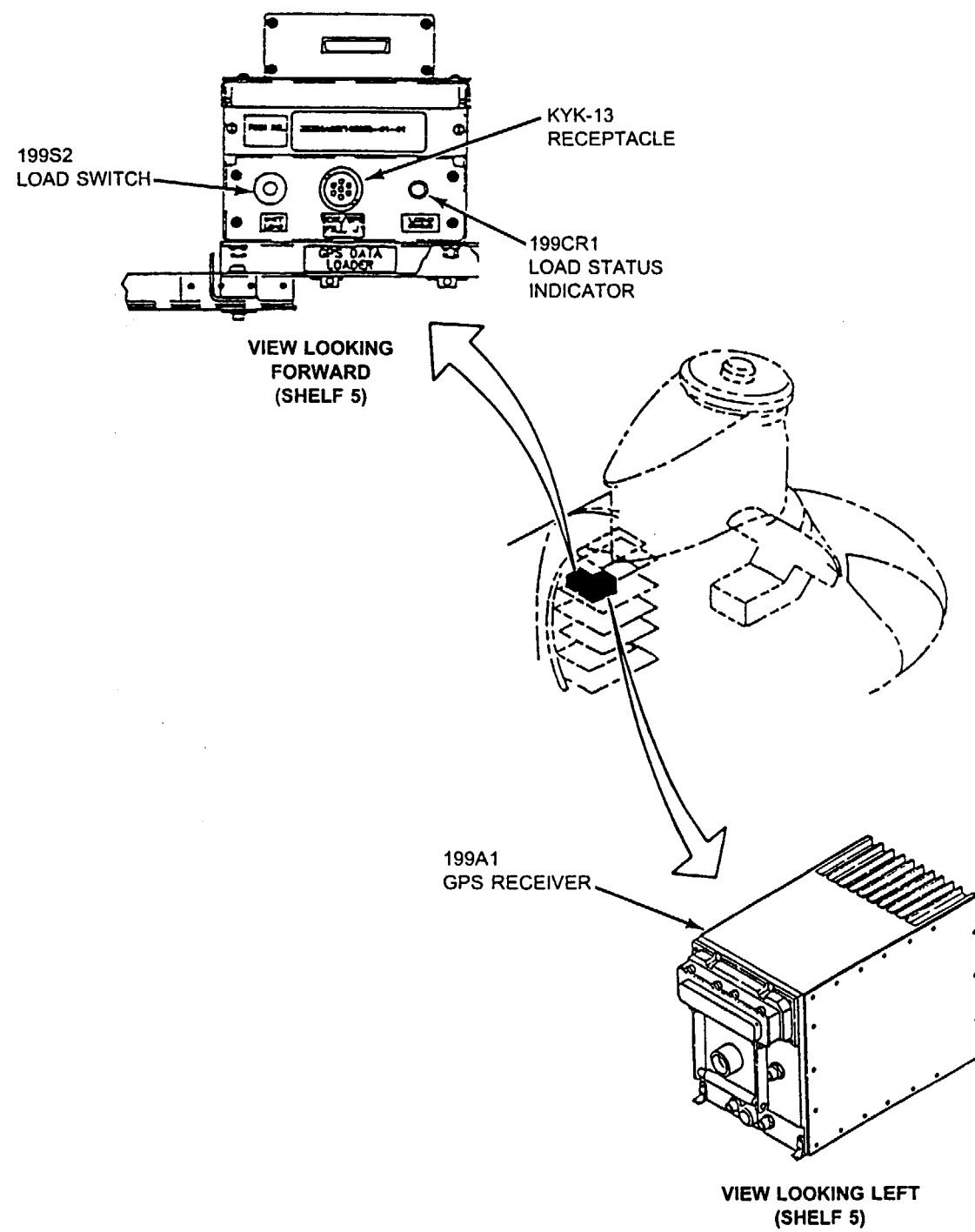

LOAD STATUS INDICATOR, 199CR1, DOES NOT FLASH WHEN LOADING KYK-13 KEYS

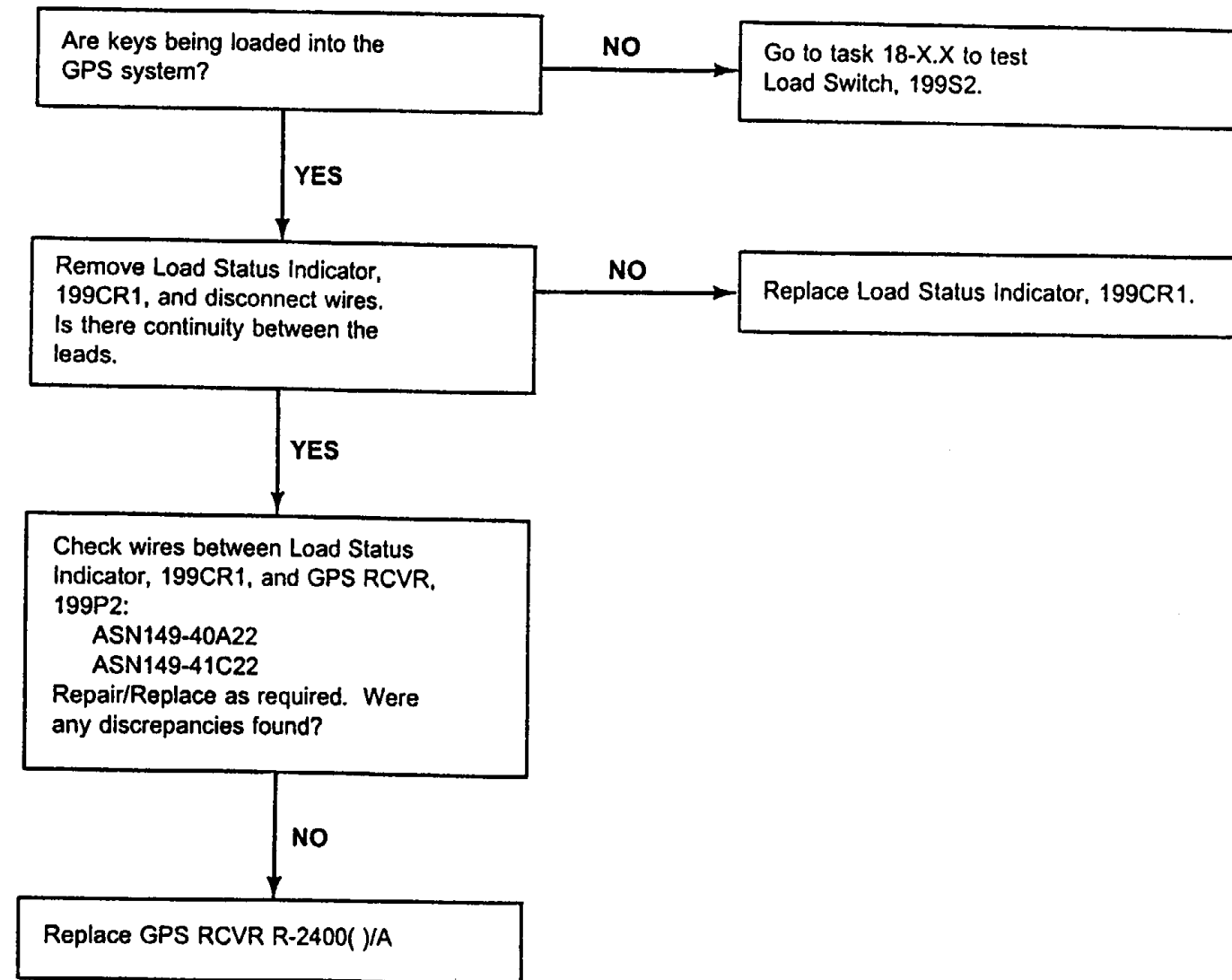

FAULT ISOLATION PROCEDURE

INITIAL SETUP

Applicable Configurations:
All

Tools:
Electrical Repairer's Tool Kit,
NSN 5180-00-323-4915
Multimeter, AN/USM-223,
NSN 6625-00-999-7465

Materials:
None

Personnel Required:
Aircraft Electrician

References:
TM 11 - 1520-240-23
TM 11-5826-308-12
TM 55-1520-240-23

Equipment Condition:
TM 55-1520-240-23:
Battery Connected
Electrical Power On
Hydraulic Power Off

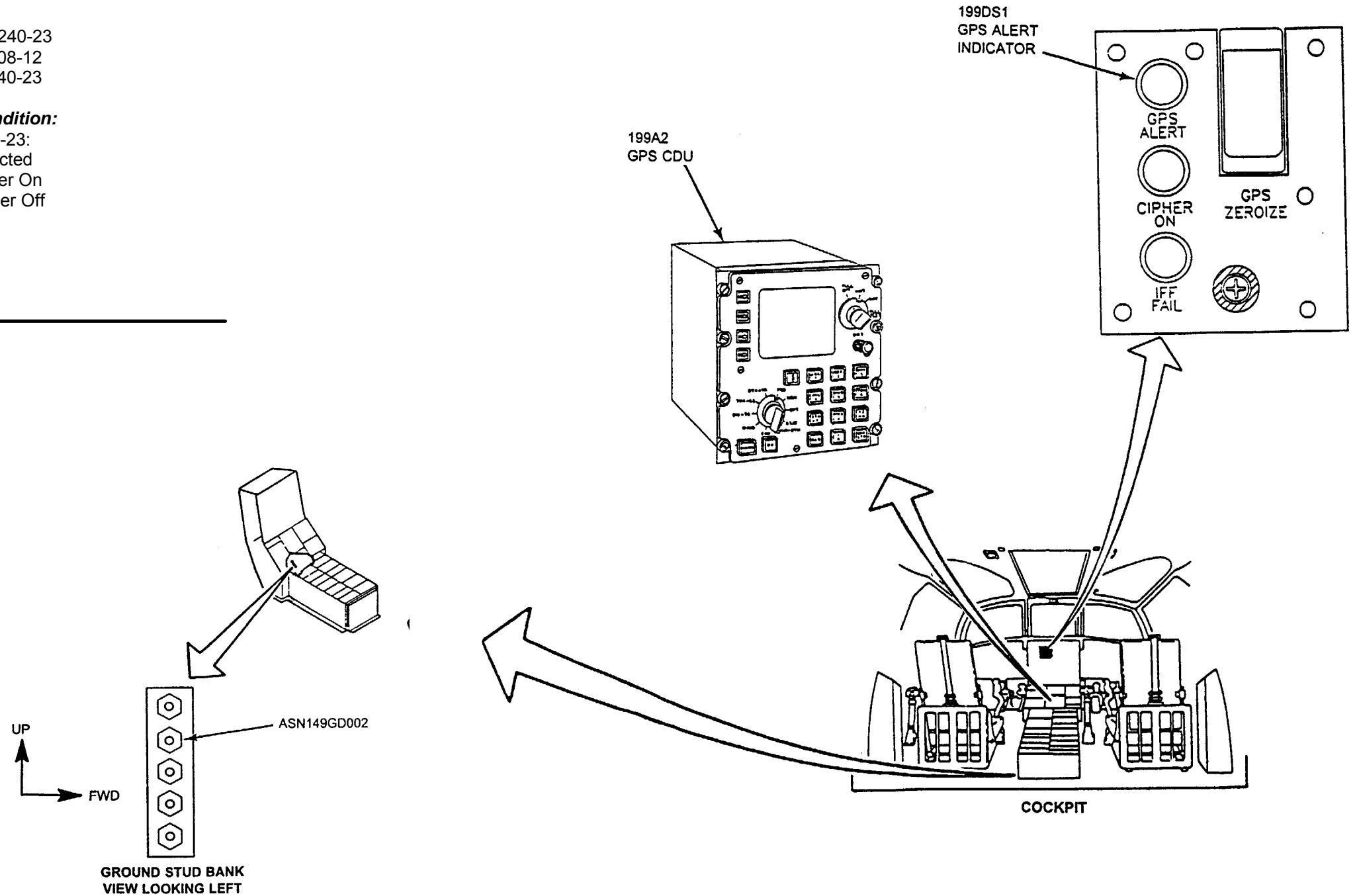

GPS ALERT INDICATOR, 199DS1, DOES NOT ILLUMINATE DURING SELF-TEST "ONLY"

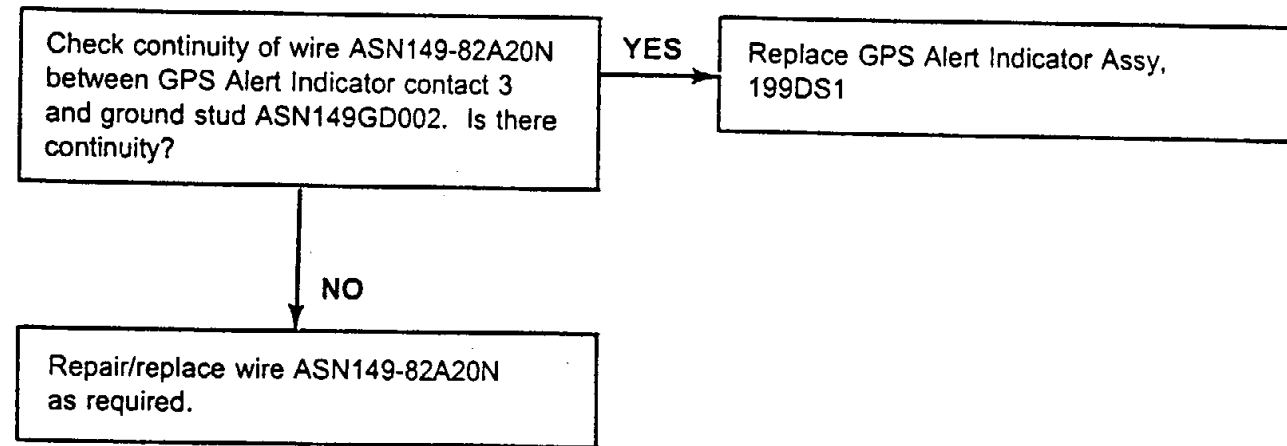

GPS ALERT INDICATOR, 199DS1, IS ALWAYS ON

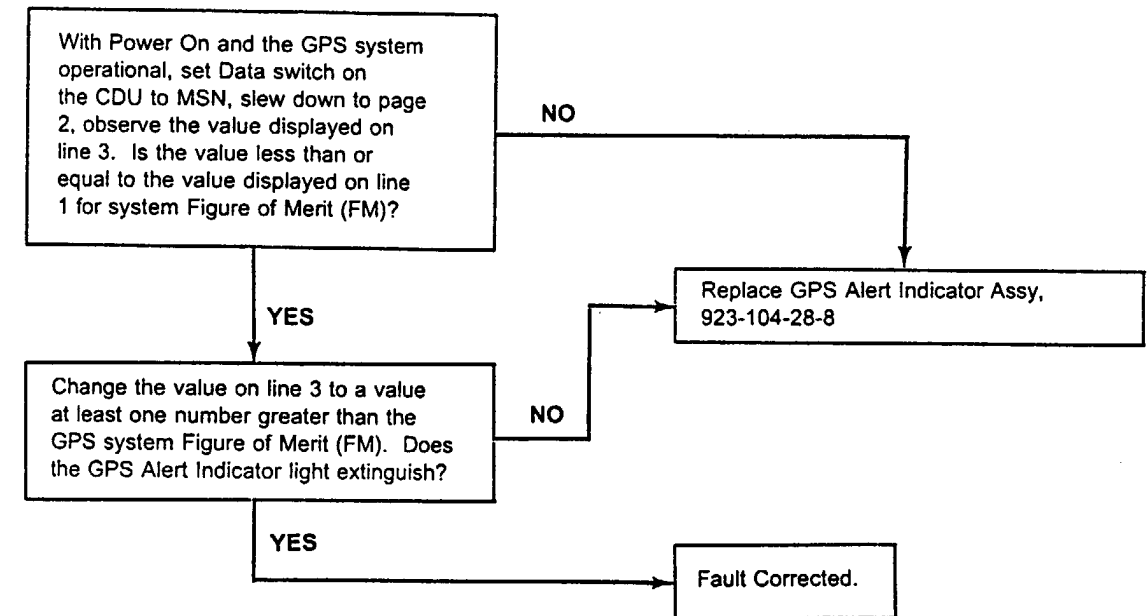

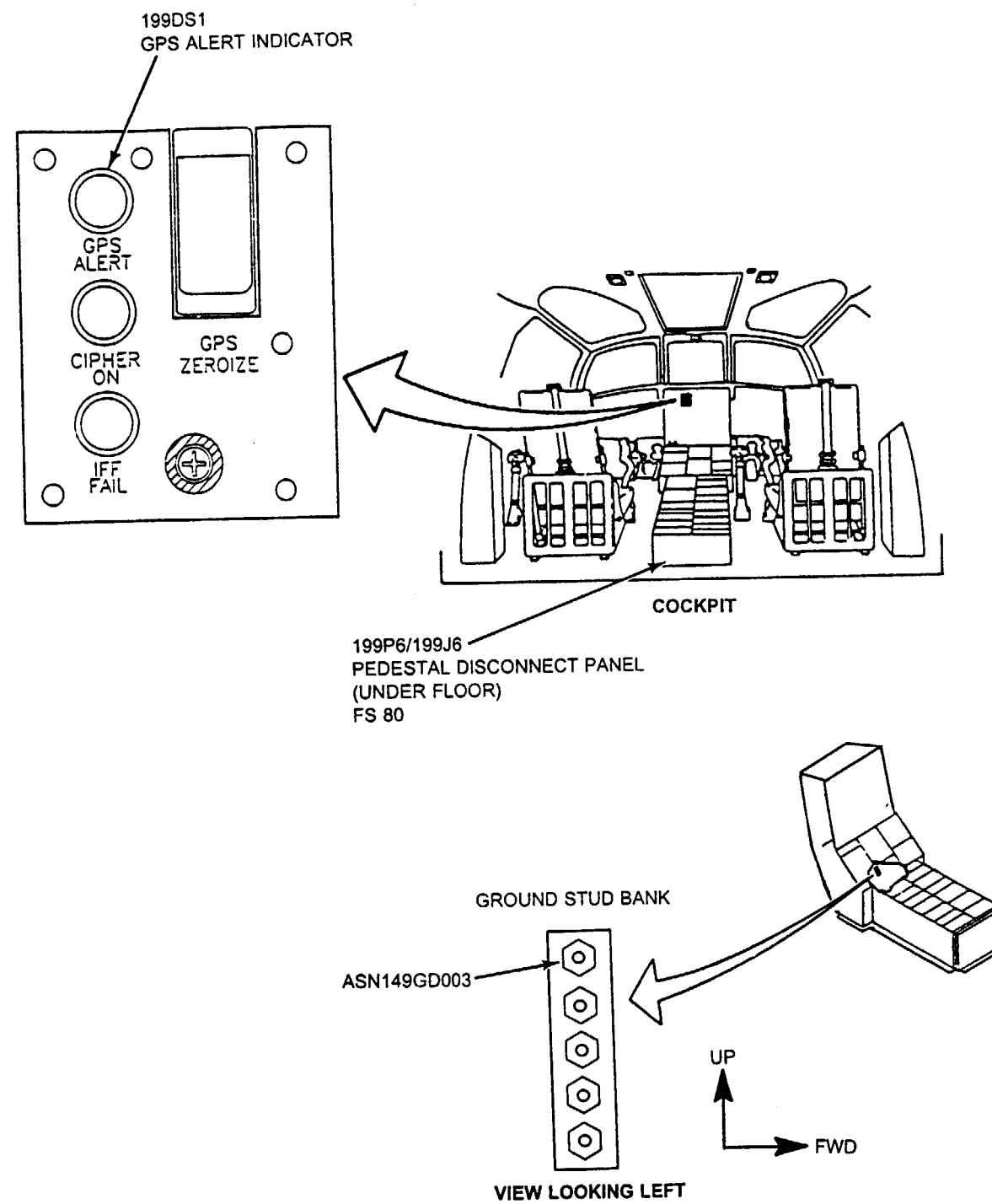
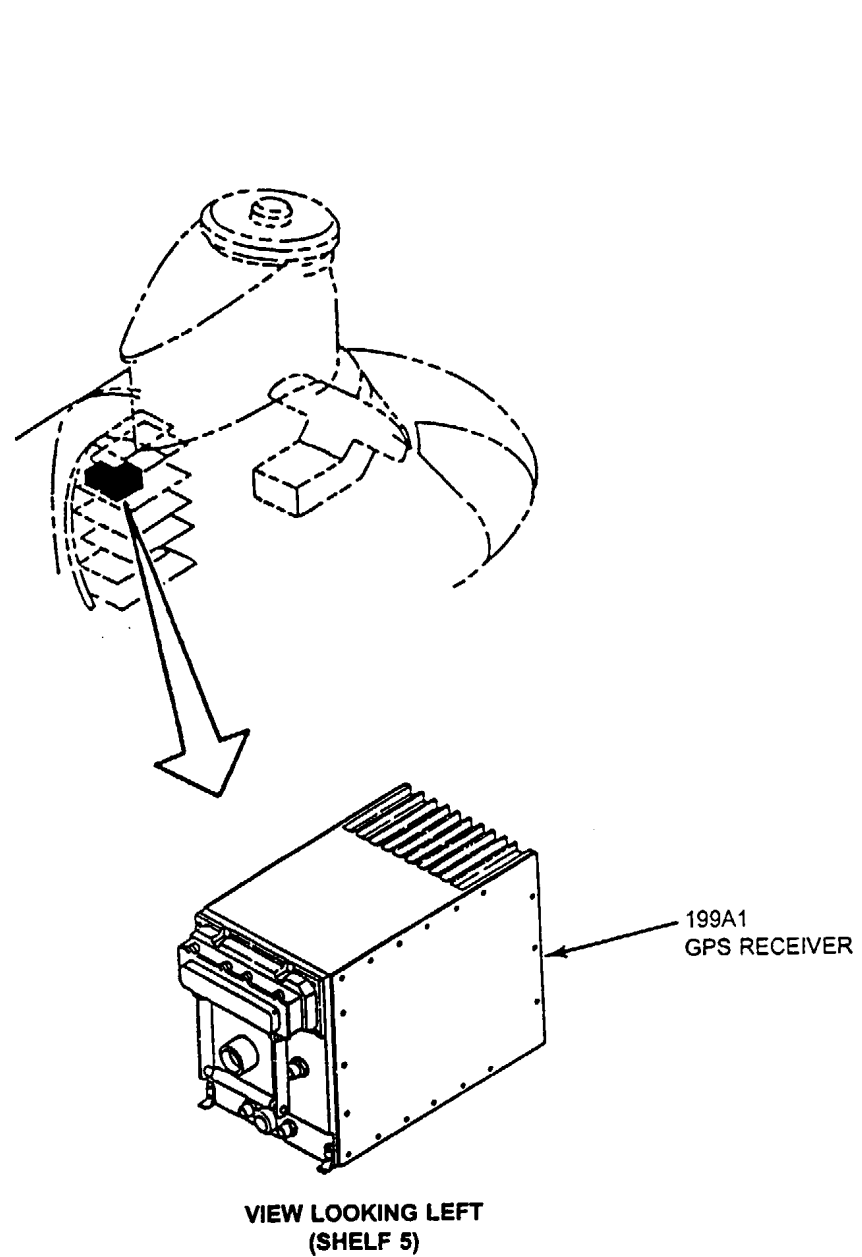

GPS ALERT INDICATOR, 199DS1, DOES NOT ILLUMINATE FOR GPS SYSTEM ALERT CONDITION "ONLY"

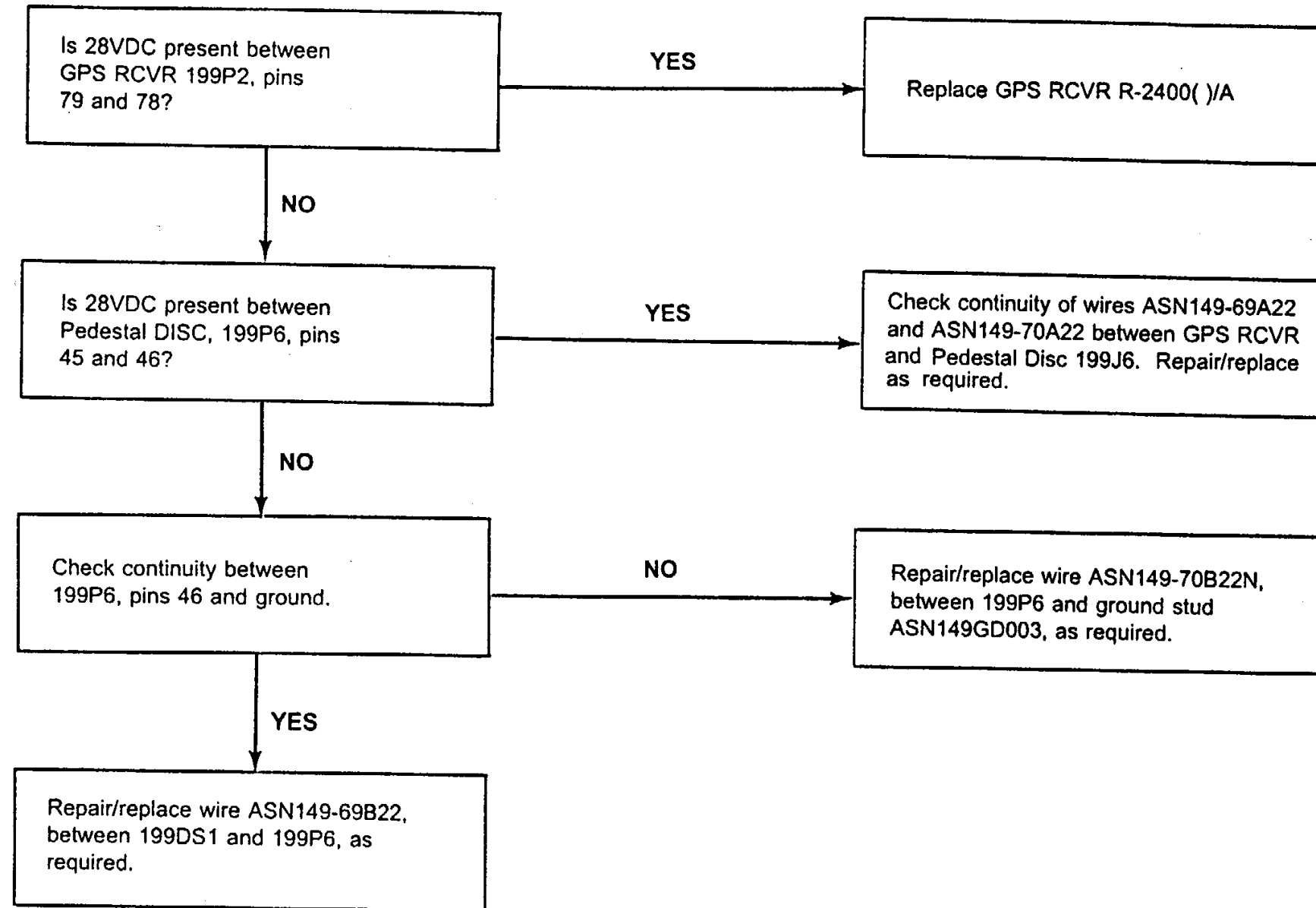

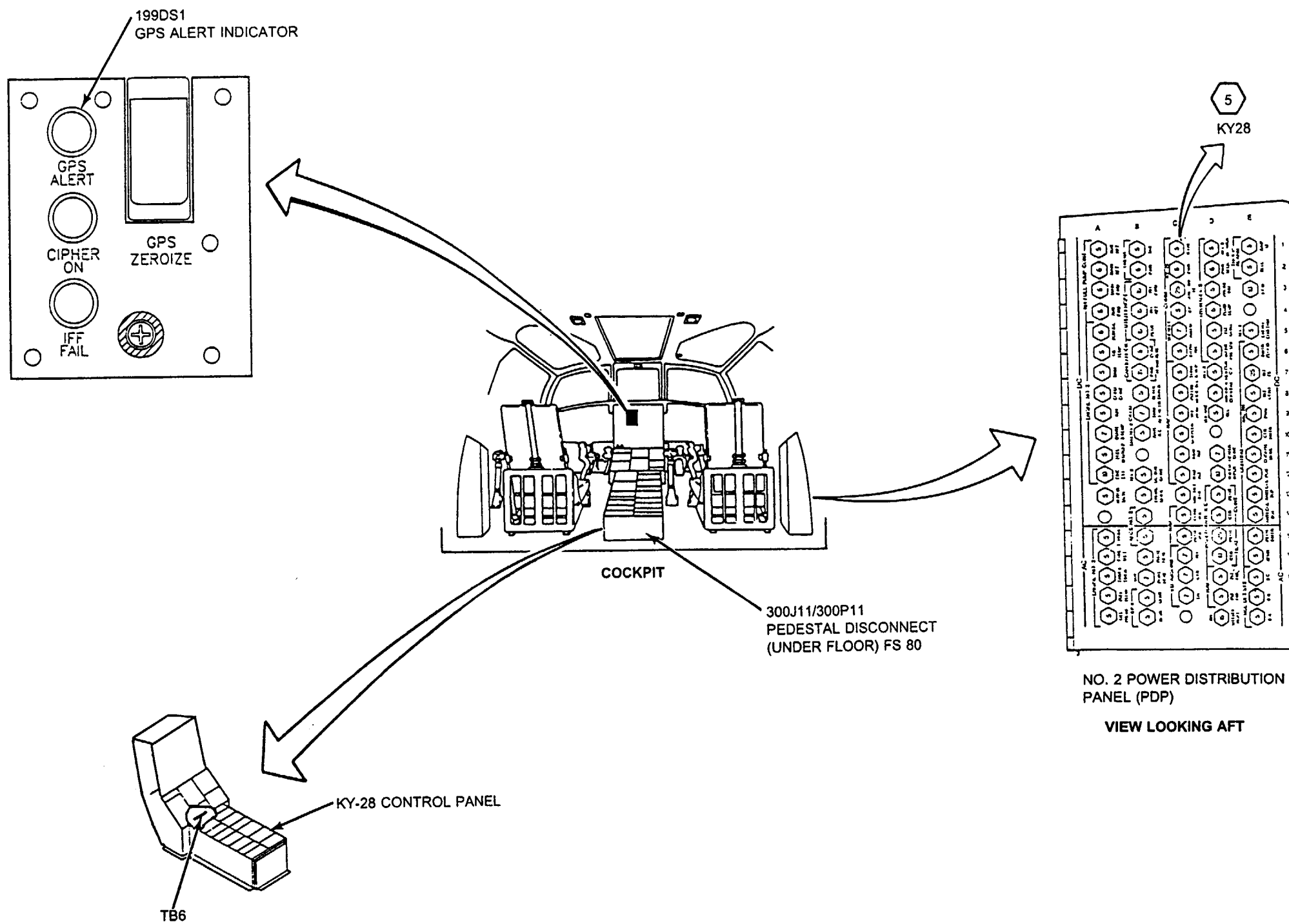

GPS ALERT INDICATOR, 199DS1, DOES NOT ILLUMINATE AT ALL

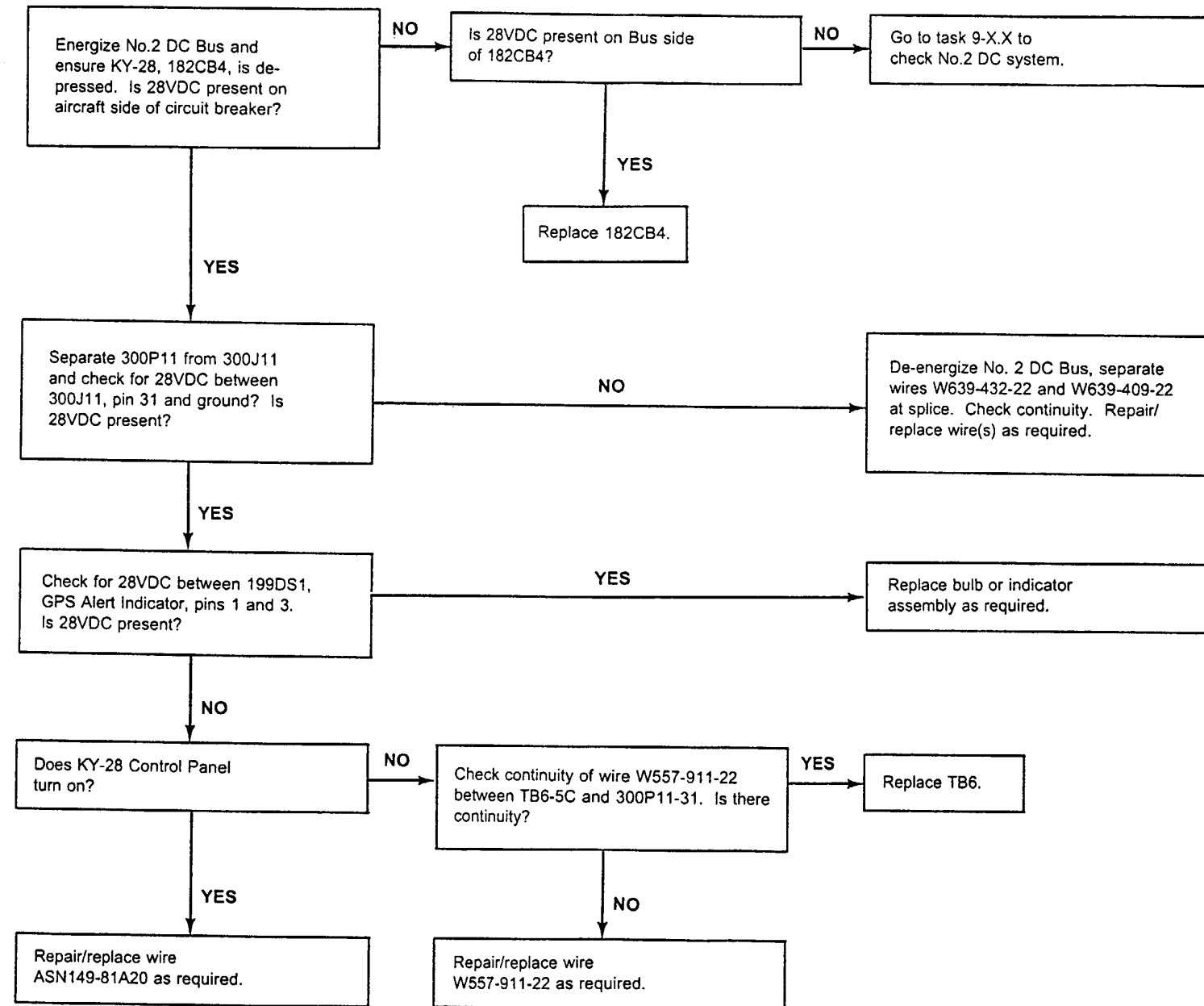

FAULT ISOLATION PROCEDURE

INITIAL SETUP

Applicable Configurations:
All

Tools:
Electrical Repairer's Tool Kit,
NSN 5180-00-323-491 5
Multimeter, AN/USM-223,
NSN 6625-00-999-7465

Materials:
None

Personnel Required:
Aircraft Electrician

References:
TM 11-1520-240-23
TM 11-5826-308-12
TM 55-1520-240-23

Equipment Condition:
TM 55-1520-240-23:
Battery Connected
Electrical Power On
Hydraulic Power Off

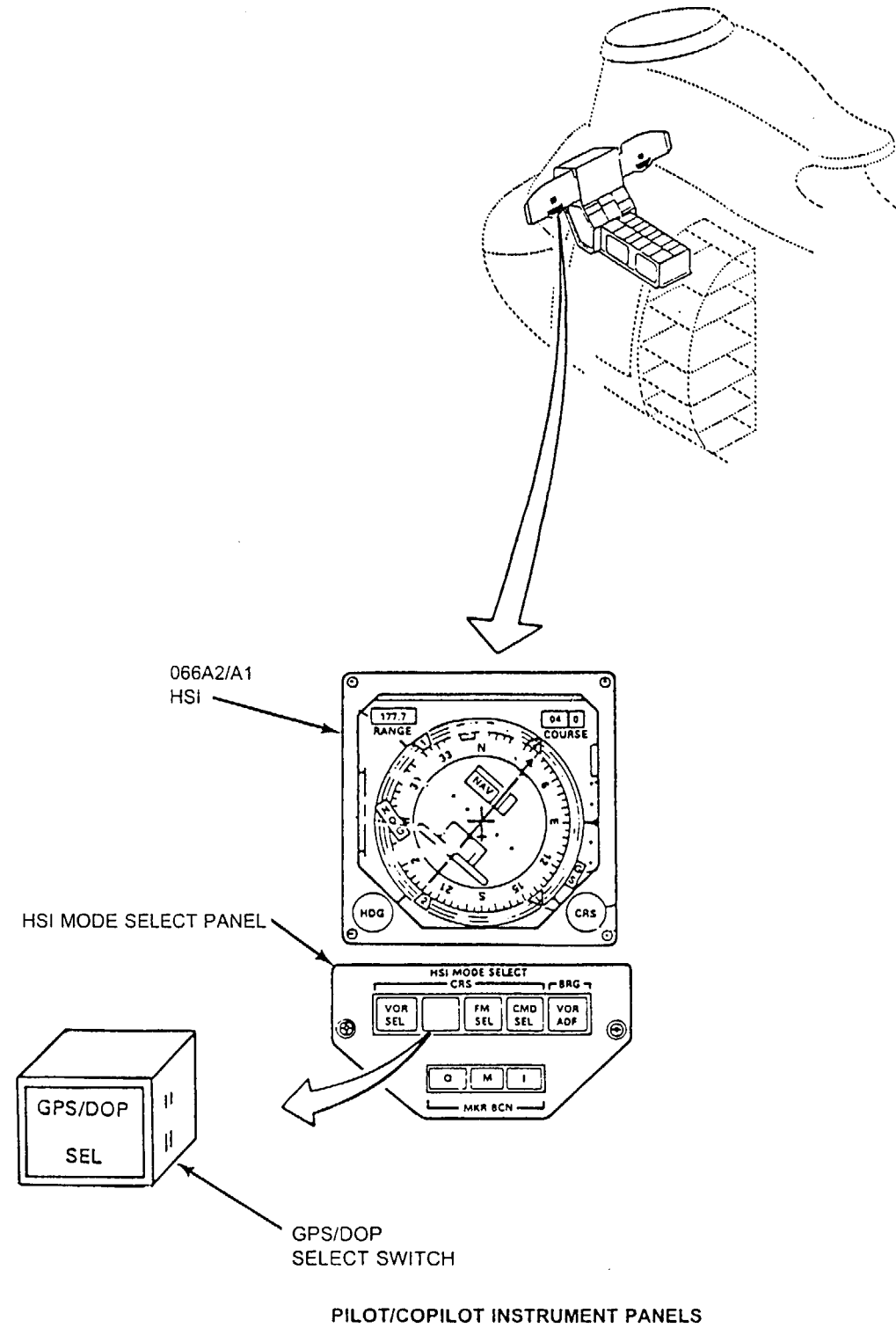

PILOT/COPILOT HSI DOES NOT DISPLAY GPS BEARING INFORMATION "ONLY"

GPS/DOP SEL LENS ON PILOT/COPILOT HSI MODE SELECT PANEL DOES NOT ILLUMINATE

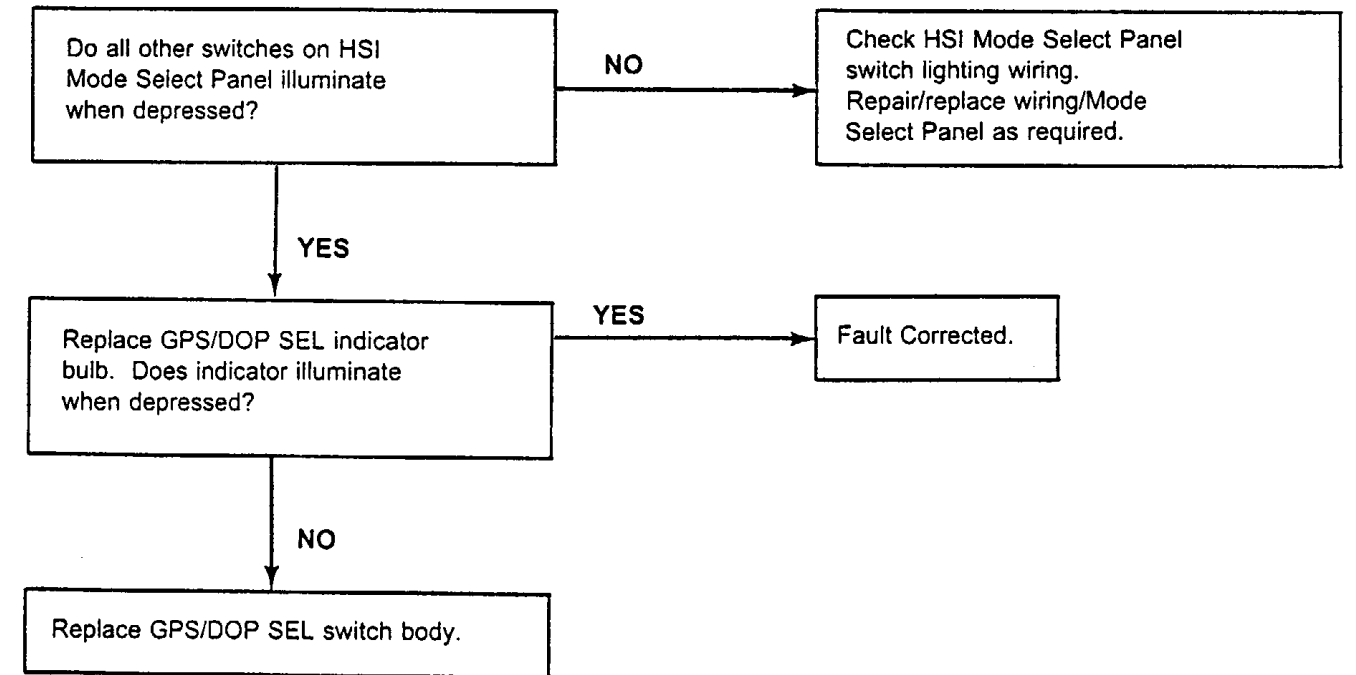
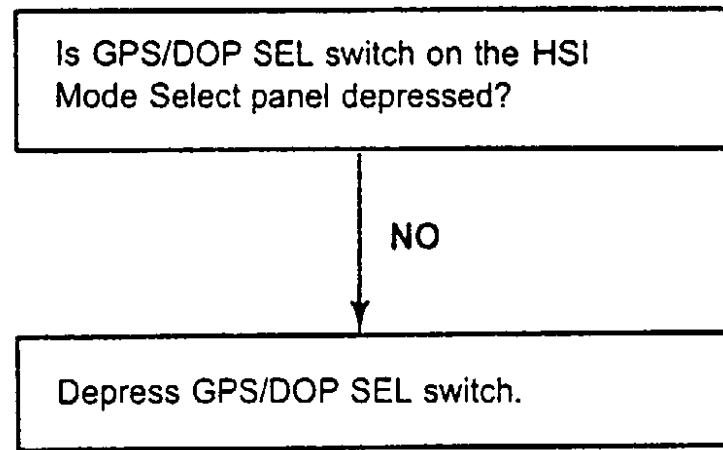

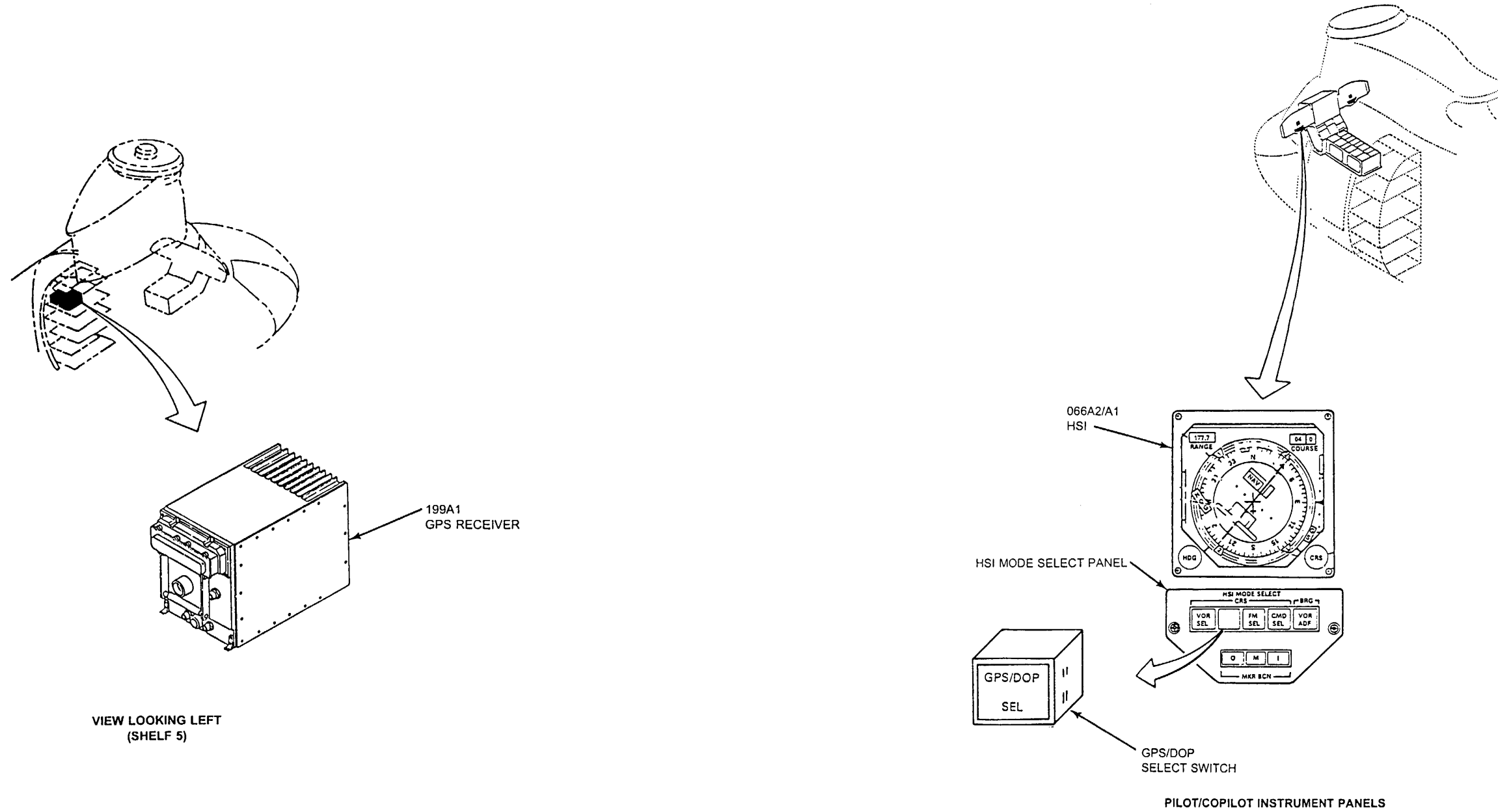

PILOT/COPILOT HSI DOES NOT DISPLAY "ANY" GPS INFORMATION
WHEN GPS/DOP SEL SWITCH IS DEPRESSED

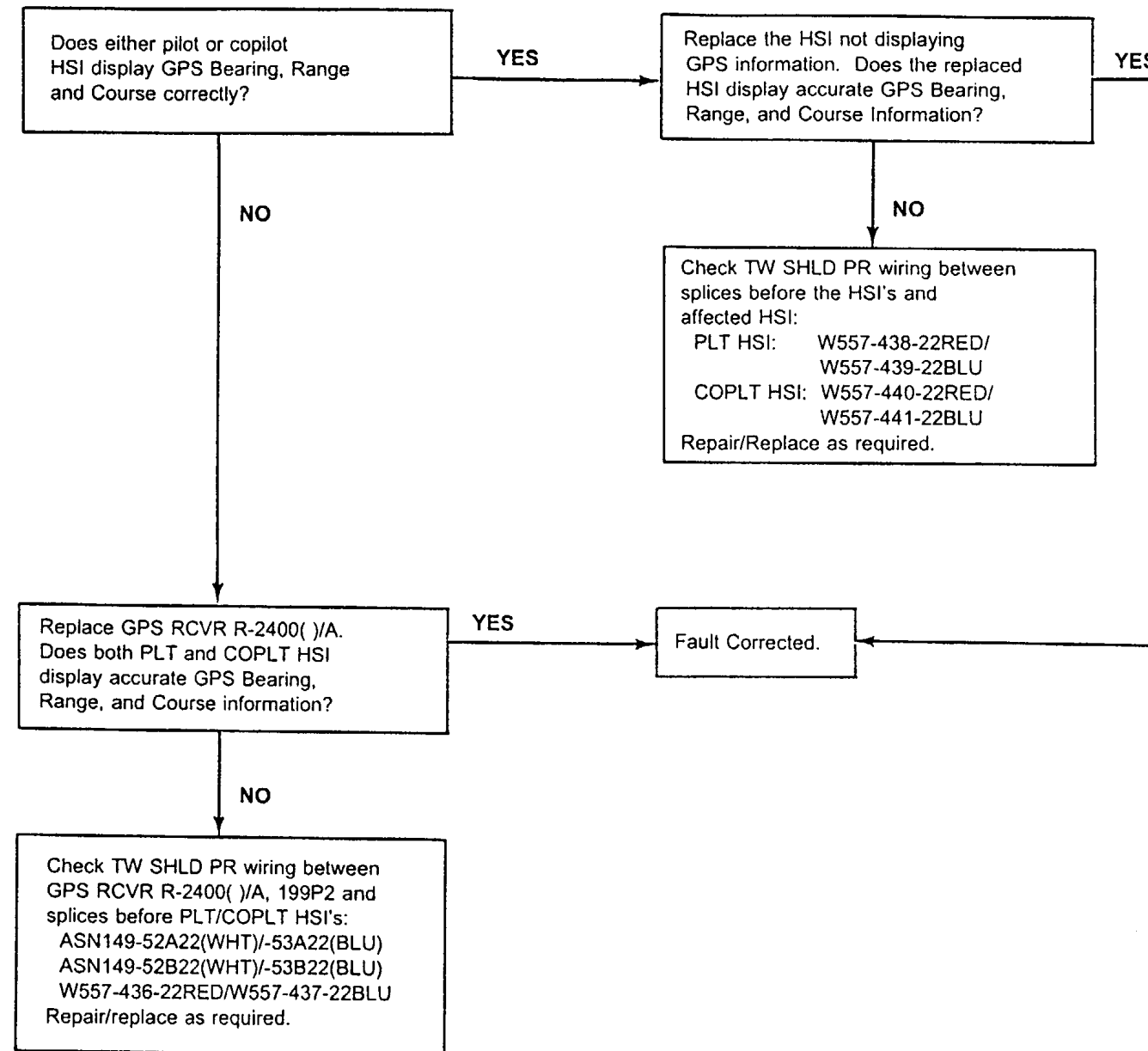

FAULT ISOLATION PROCEDURE

INITIAL SETUP

Applicable Configurations:
All

Tools:
Electrical Repairer's Tool Kit,
NSN 5180-00-323-4915
Multimeter, AN/USM-223,
NSN 6625-00-999-7465

Materials:
None

Personnel Required:
Aircraft Electrician

References:
TM 11-5826-308-12
TM 55-1520-240-23

Equipment Condition:
TM 55-1520-240-23:
Battery Disconnected
Electrical Power Off
Hydraulic Power Off

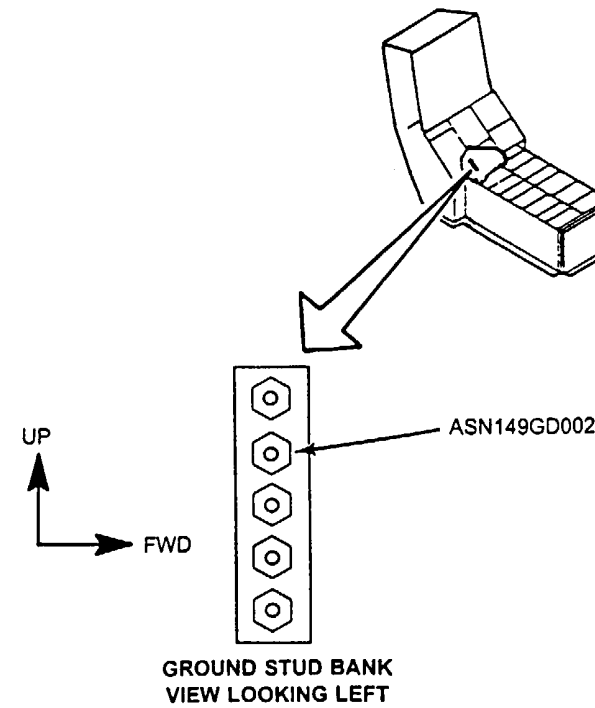
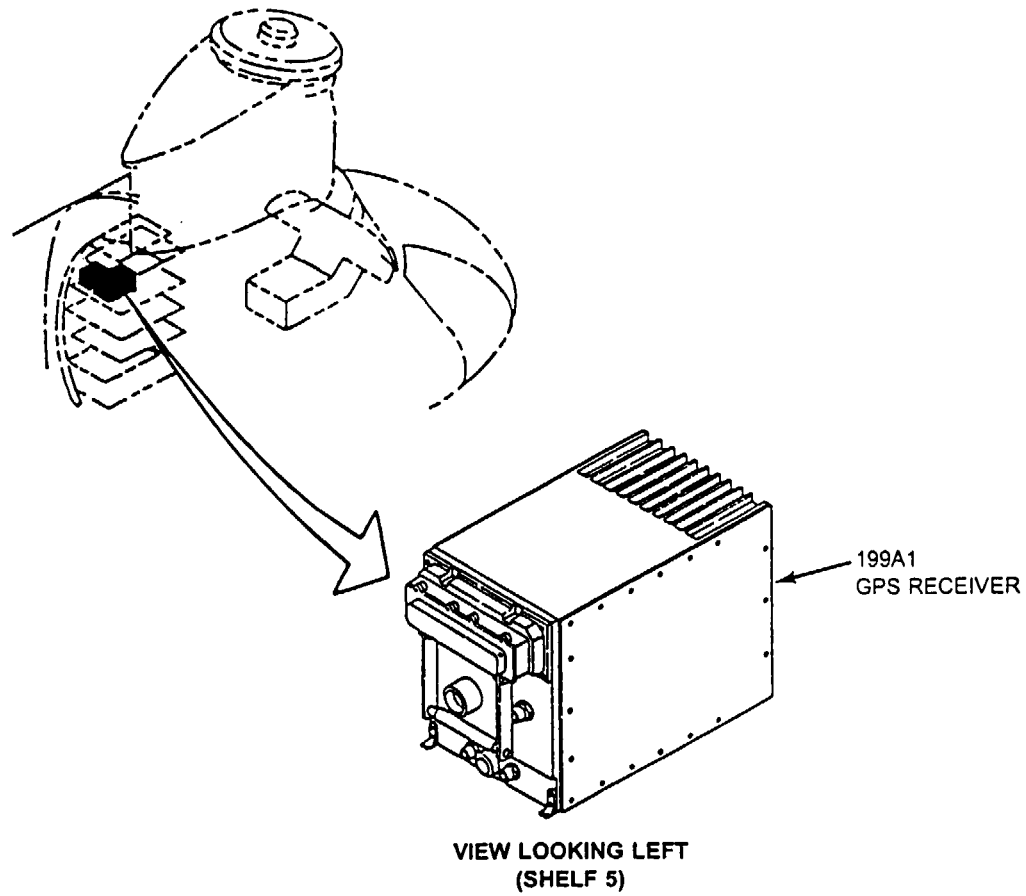
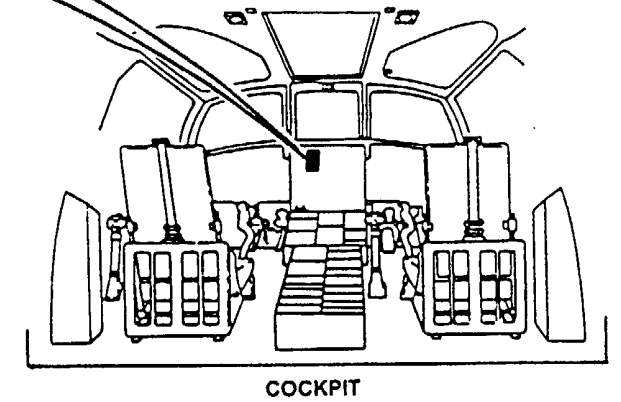
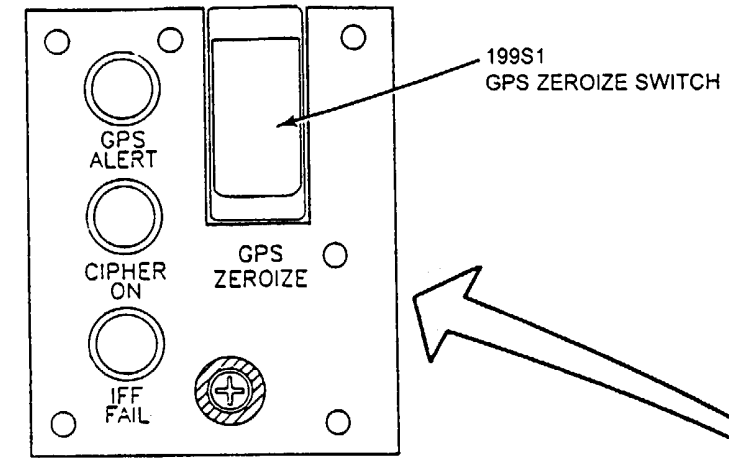

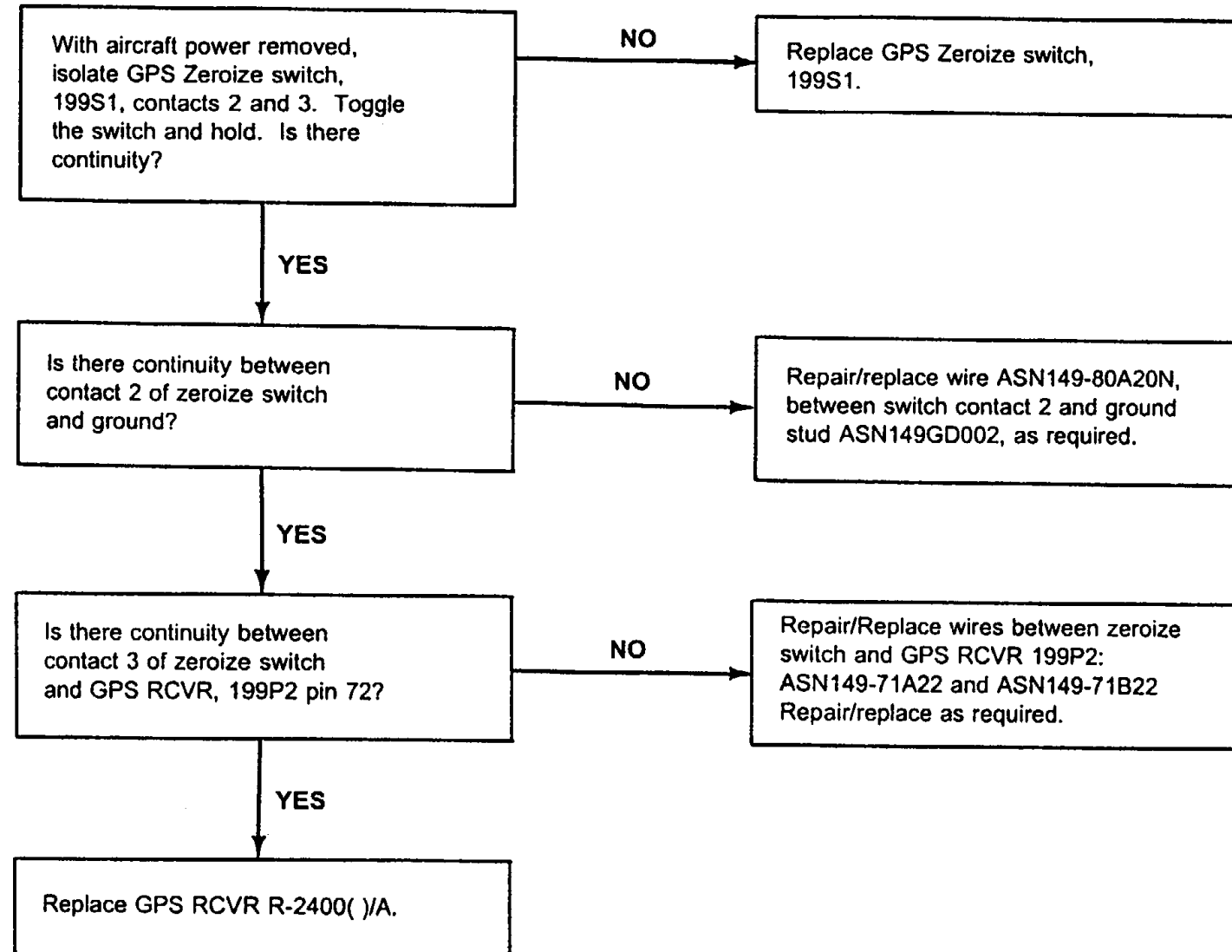

FAULT ISOLATION PROCEDURE

INITIAL SETUP

Applicable Configurations:
All

Tools:
Electrical Repairer's Tool Kit,
NSN 5180-00-323-4915

Materials:
None

Personnel Required:
Aircraft Electrician

References:
TM 11-5826-308-12
TM 55-1520-240-23

Equipment Condition:
TM 55-1520-240-23:
Battery Connected
Electrical Power On
Hydraulic Power Off

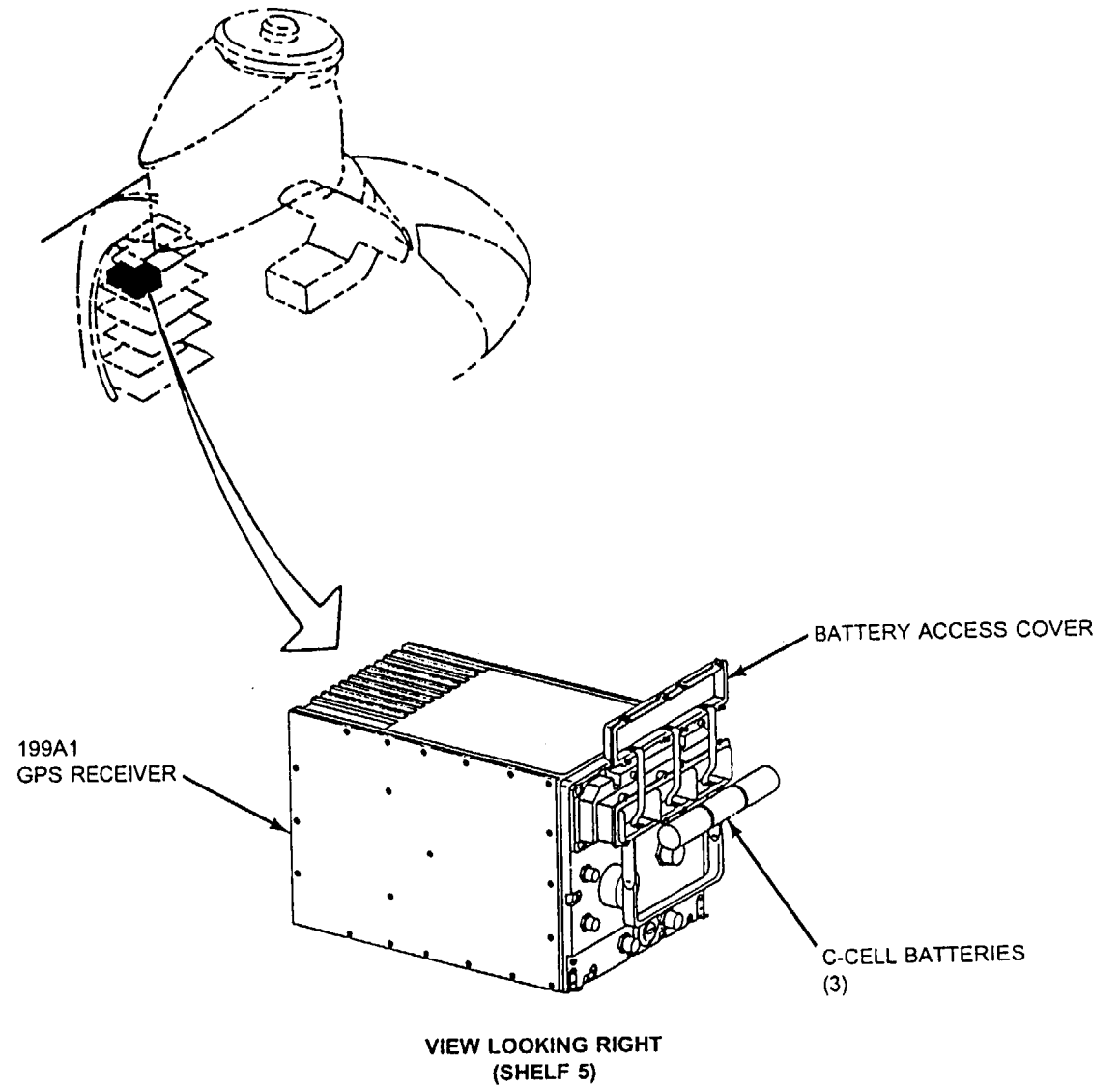
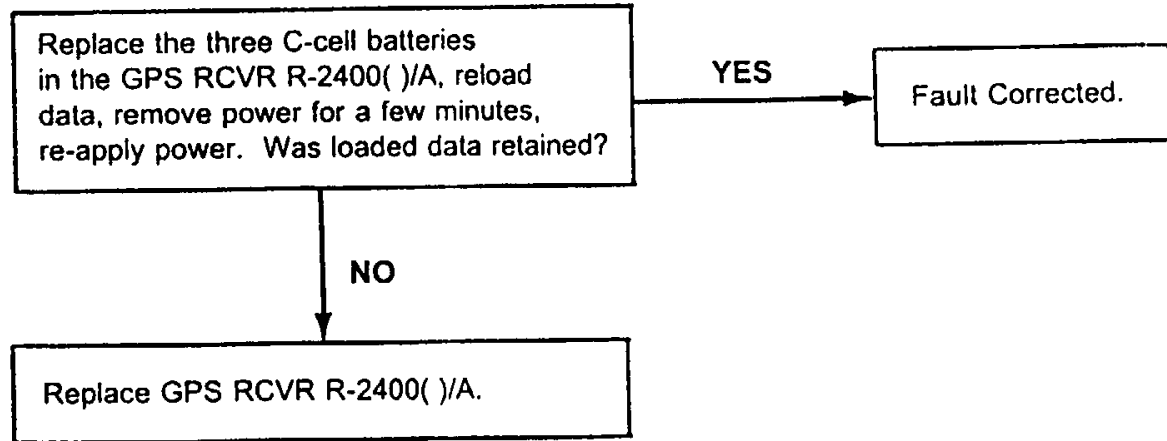

18-2 ALTITUDE VOICE WARNING SYSTEM
(RADAR ALTIMETER)

Change 18 18-47/(18-48 blank)

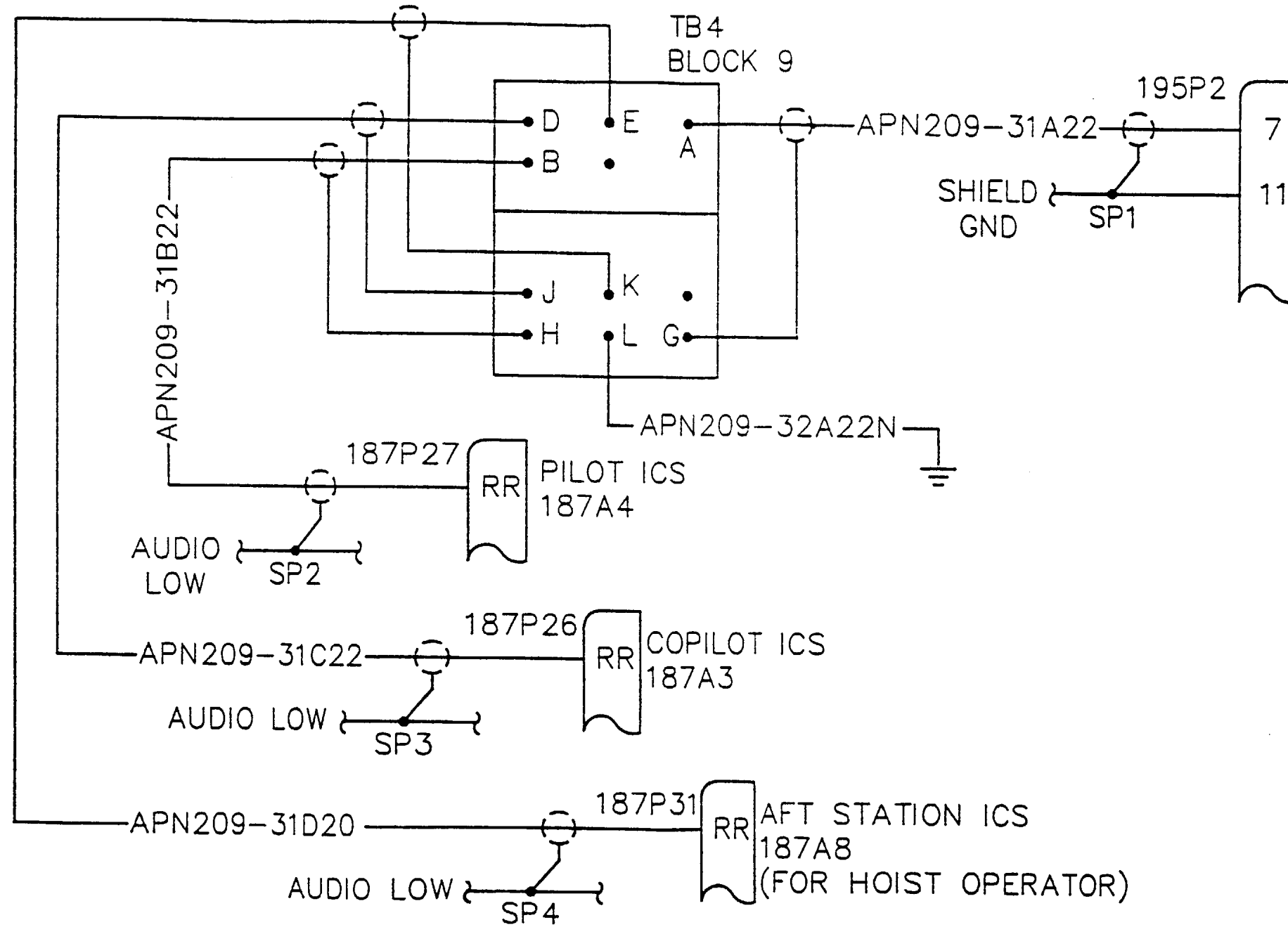

INITIAL SETUP

Applicable Configurations:
All

Tools:
Electrical Repairer's Tool Kit,
NSN 5180-00-323-4915

Materials:
None

Personnel Required:
68F10 Aircraft Electrician

References:
TM 11-1520-240-23
TM 55-1520-240-23

Equipment Condition:
TM 55-1520-240-23:
Battery Disconnected
Electrical Power Off
No. 2 Access Door (Tunnel Cover)
Open

TASK	RESULT
1. Check AVWS Radar Altimeter Indicator	Remove from Pilot's instrument panel and (AN/APN209) (1). check connector of AVWS Radar Altimeter Indicator (1). If connector is loose or damaged, tighten, repair, or replace as required. If wiring to connector is loose or damaged, tighten, repair, or replace it as required. If indicator glass is cracked or broken, or if pointers/indices are bent or broken replace altimeter. Check knobs for looseness or binding. Repair, replace, or adjust as required.
2. Check the following Interphone Control Panels: Pilot (2) Copilot (3) Aft Station (4).	Remove each panel and check connector. If connector is loose or damaged, tighten, repair, or replace as required. If wiring to connector is loose or damaged, tighten, repair, or replace as required. Check knobs for looseness or binding. Repair, replace, or adjust as required. Check switches for looseness or binding. Replace as required.

FOLLOW-ON MAINTENANCE:

None

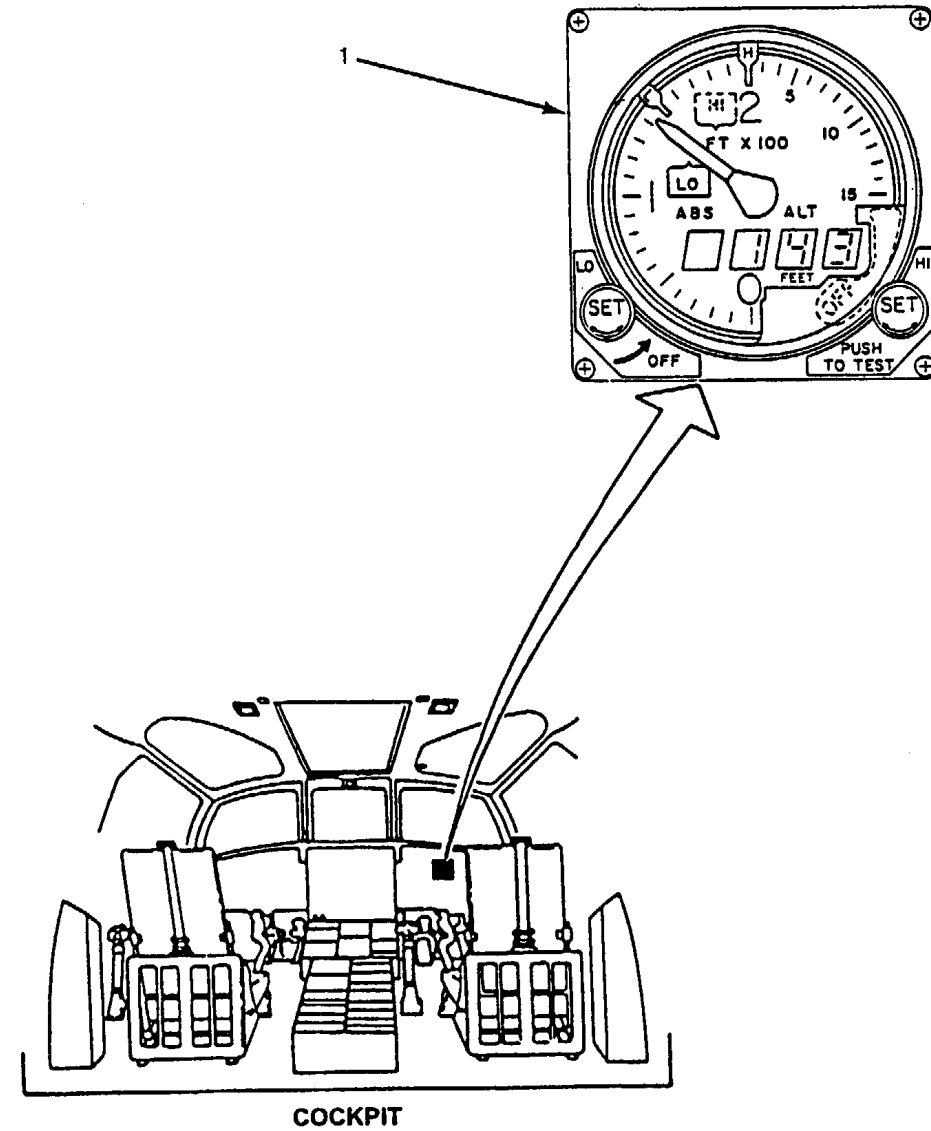

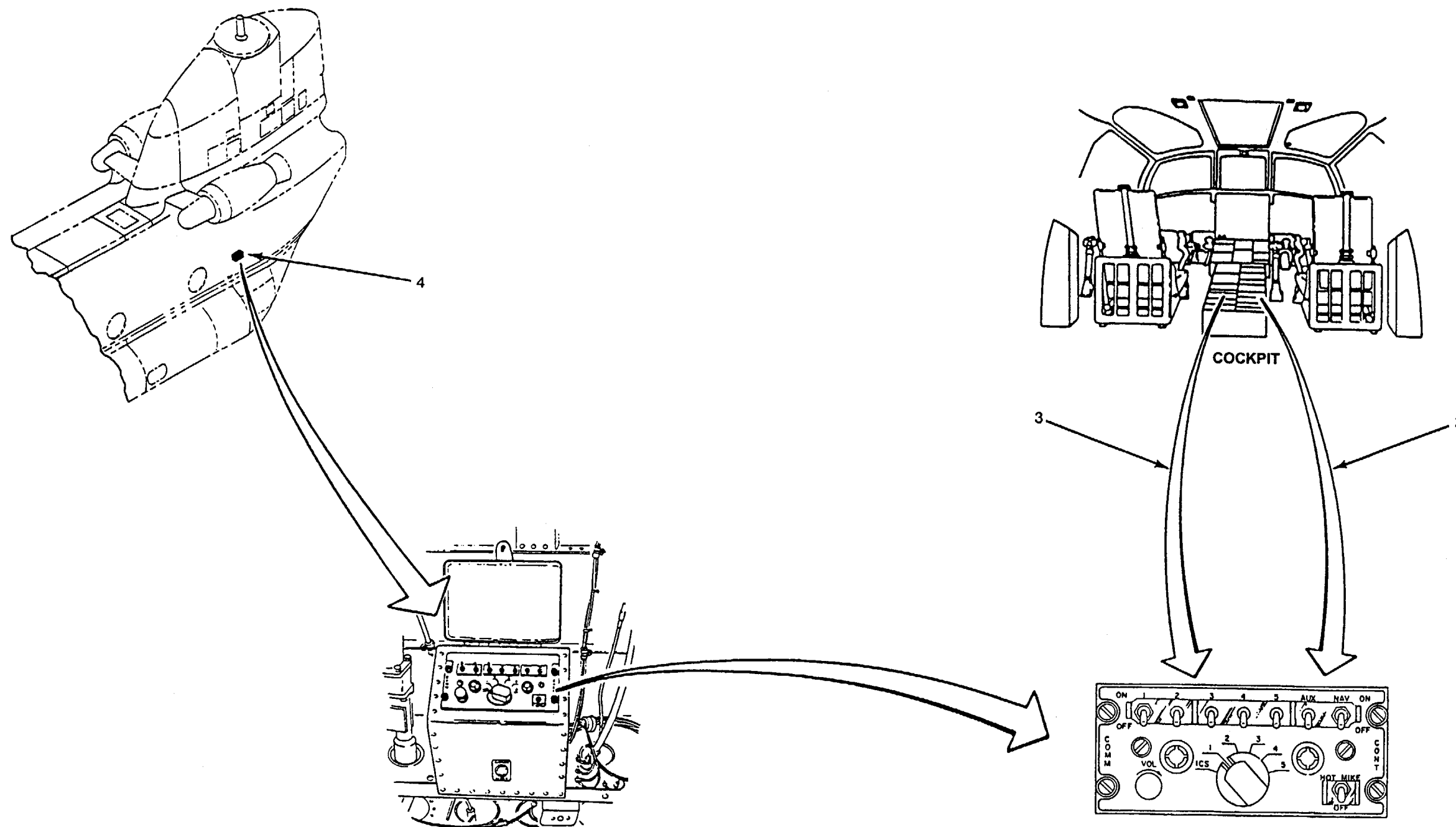

INITIAL SETUP

Applicable Configurations:

All

Tools:

Electrical Repairer's Tool Kit,
NSN 5180-00-323-4915

Materials:

None

Personnel Required:

Aircraft Electrician (2)

References:

TM 11-1520-240-23
TM 55-1520-240-23

Equipment Condition:

TM 55-1520-240-23:
Battery Connected
Electrical Power Off
Hydraulic Power Off
Altitude Voice Warning System Visual Check
Performed (Task 18-2.2)

TASK	RESULT
------	--------

CHECK CIRCUIT BREAKERS

- | | |
|--|---|
| 1. Check that the following circuit breaker on No. 1 pdp are closed:
INTPH LH (1) | If circuit breaker is open (1), close it. |
| 2. Check that the following circuit breakers on No. 2 pdp are closed:
INTPH RH (2)
RAD ALT (3) | If any circuit breaker is open (2 and 3), close it. |
| 3. Start APU. Refer to task 15-1.4 | APU ON capsule shall come on. |

CHECK AVWS OPERATION

NOTE

- The following checks will only cover the Altitude Voice Warning portion of the Radar Altimeter operation. For indication discrepancies, refer to TM 11-1520-240-23.
- Ensure that the pilot, copilot, and aft interphone stations are all operational.

- | | |
|--|---|
| 4. With the pilot's Radar Altimeter (4) turned ON and the OFF Flag (5) not visible, and with a headset connected to the pilot's headset jack, rotate the LO SET knob (6) to position the LO SET Index (7.) just above the OFF detent. Adjust the HI SET knob (8) to position the HI SET Index (9) at 100 feet. | The warning message "ALTITUDE LOW, TOO LOW" should NOT be heard. If this message is heard, go to task 18-2.6. |
|--|---|

TASK	RESULT
5. Adjust the LO SET Index (7) to approximately the 10 foot position on the indicator.	The warning message "ALTITUDE LOW, TOO LOW" shall be heard at FULL volume. If this message is NOT heard or volume is NOT FULL, go to task 18-2.4.
6. Momentarily depress the PUSH-TO-TEST knob (6) once.	The volume of the low altitude warning message shall decrease by one-half (1/2). If volume stays full, or NOT heard at all, go to task 18-2.5.
7. Reset the LO SET Index (7) to a point just above the OFF detent, wait 11 seconds, and return LO SET index to the 10 feet mark.	The low altitude warning message shall be heard at FULL volume. If message is NOT heard at all, or if volume is NOT full, go to task 18-2.4.
8. Press and hold the PRESS-TO-TEST knob (8) to activate the self-test.	The warning message "ALTITUDE HIGH, CHECK ALTITUDE" shall be audible at FULL volume. If message is NOT heard, or if volume is NOT full, go to task 18-2.4.
9. Release the PUSH-TO-TEST knob.	The warning message "ALTITUDE LOW, TOO LOW" shall be again heard, at FULL volume. If message is NOT heard, or if volume is NOT full, go to task 18-2.4.
10. Repeat steps 4 thru 9 with a headset connected to the copilot's headset jack.	Results shall be as specified in steps 4 thru 9. If altitude warning messages are not audible, even after replacing Radar Altimeter (4), go to task 18-2.4.
11. Repeat steps 4 thru 9 with a headset connected to the hoist operator's headset jack.	Results shall be as specified in steps 4 thru 9. If altitude warning messages are not audible, even after replacing Radar Altimeter (4), go to task 18-2.4.

FOLLOW-ON MAINTENANCE:

TM 55-1520-240-23:
Battery Disconnected
Electrical Power Off

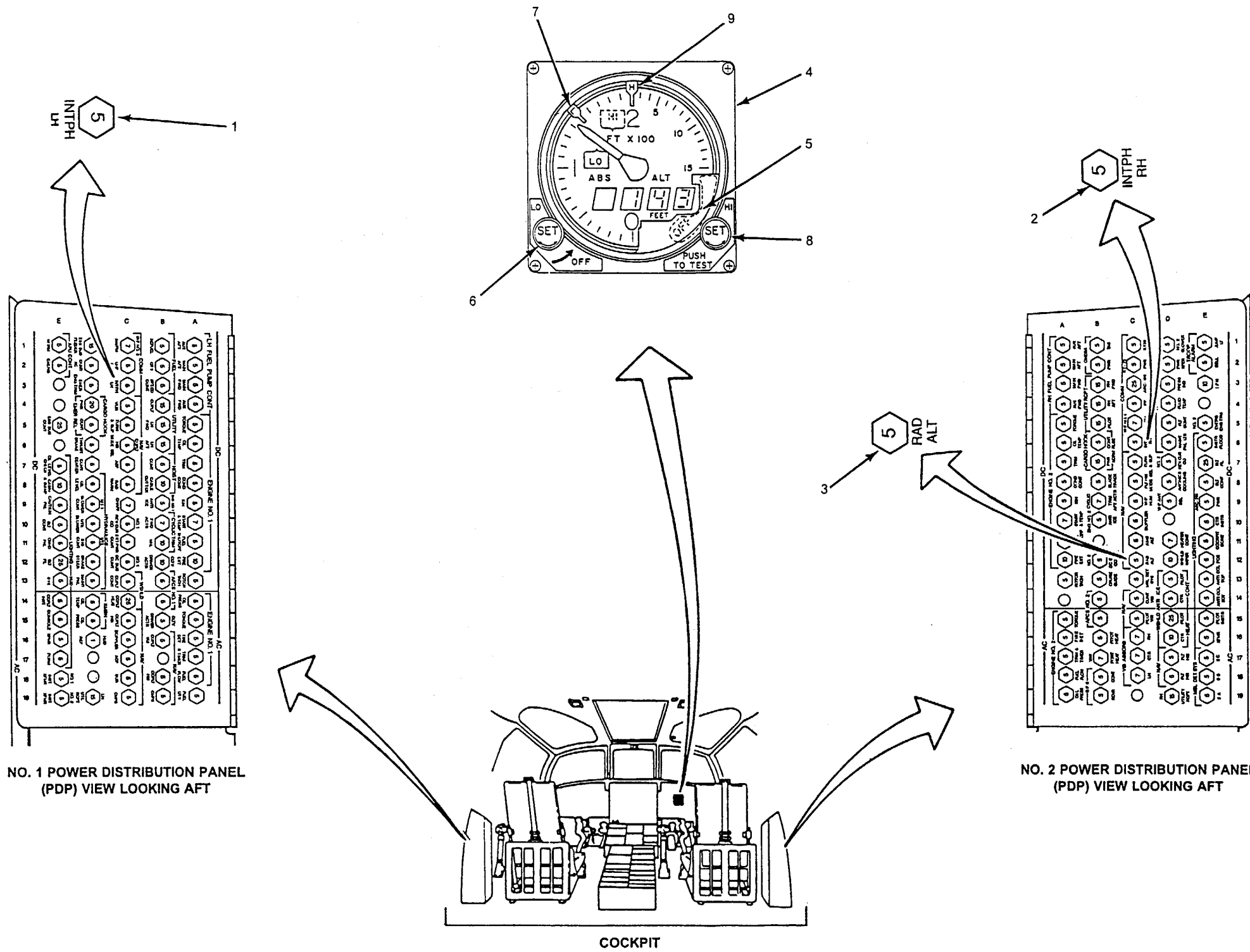

NO. 1 POWER DISTRIBUTION PANEL (PDP) VIEW LOOKING AFT

NO. 2 POWER DISTRIBUTION PANEL (PDP) VIEW LOOKING AFT

COCKPIT

18-2.4 ALTITUDE VOICE WARNING NOT AUDIBLE AT PILOT, COPILOT, OR AFT STATION/HOIST OPERATOR'S HEADSET WHEN PILOT'S RADAR ALTIMETER ALTITUDE POINTER IS BELOW OR ABOVE PRESET ALTITUDE LIMITS

FAULT ISOLATION PROCEDURE

INITIAL SETUP

Applicable Configurations:
All

References:
TM 11-1520-240-23
TM 55-1520-240-23

Tools:
Electrical Repairer's Tool Kit,
NSN 5180-00-323-4915
Multimeter, AN/USM-223,
NSN 6625-00-999-7465

Equipment Condition:
TM 55-1520-240-23:
Battery Connected
Electrical Power On
Hydraulic Power Off

Materials:
None

Personnel Required:
Aircraft Electrician (2)

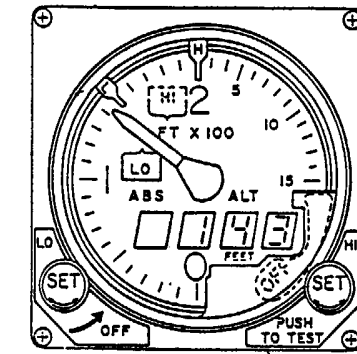
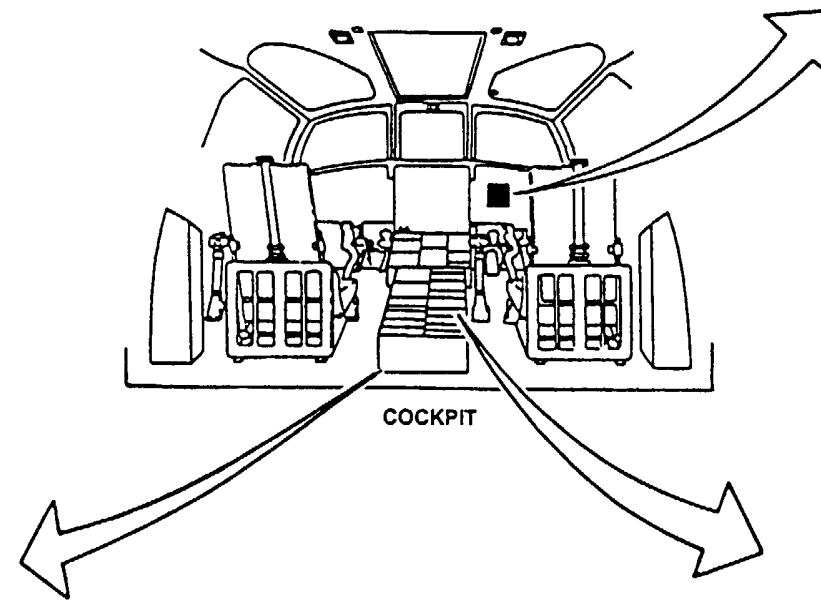
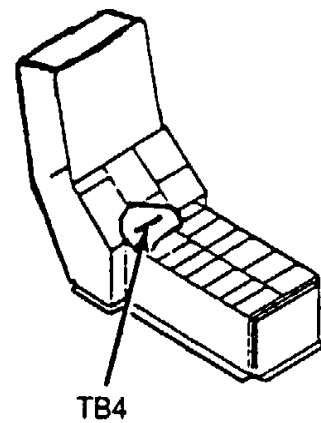

195A1
RADAR ALTIMETER
RECEIVER-TRANSMITTER
INDICATOR

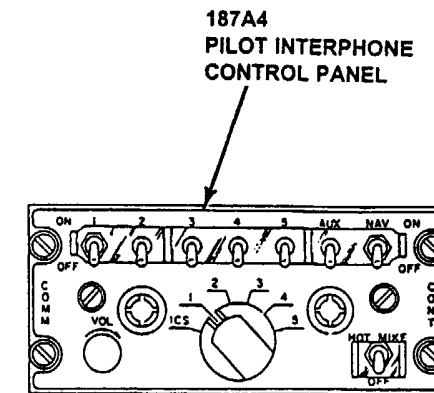

187A4
PILOT INTERPHONE
CONTROL PANEL

18-2.4 ALTITUDE VOICE WARNING NOT AUDIBLE AT PILOT, COPILOT, OR AFT STATION/HOIST OPERATOR'S HEADSET WHEN PILOT'S RADAR ALTIMETER ALTITUDE POINTER IS BELOW OR ABOVE PRESET ALTITUDE LIMITS (Continued)

ALTITUDE VOICE WARNING NOT AUDIBLE AT ALL INTERPHONE STATIONS (PILOT, COPILOT, AND AFT/HOIST OPERATOR)

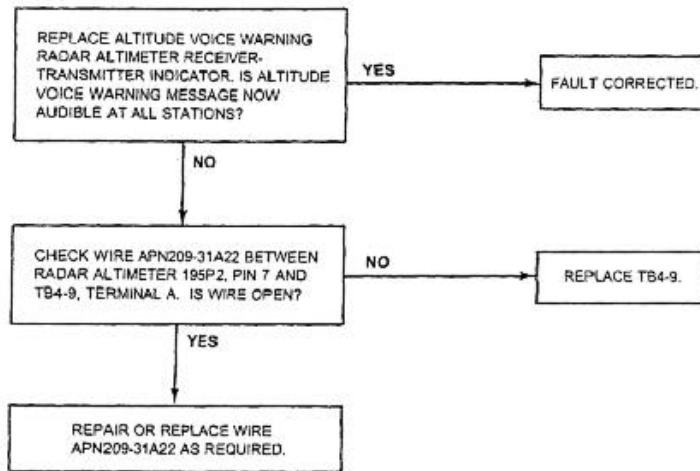

ALTITUDE VOICE WARNING NOT AUDIBLE AT PILOT STATION ONLY

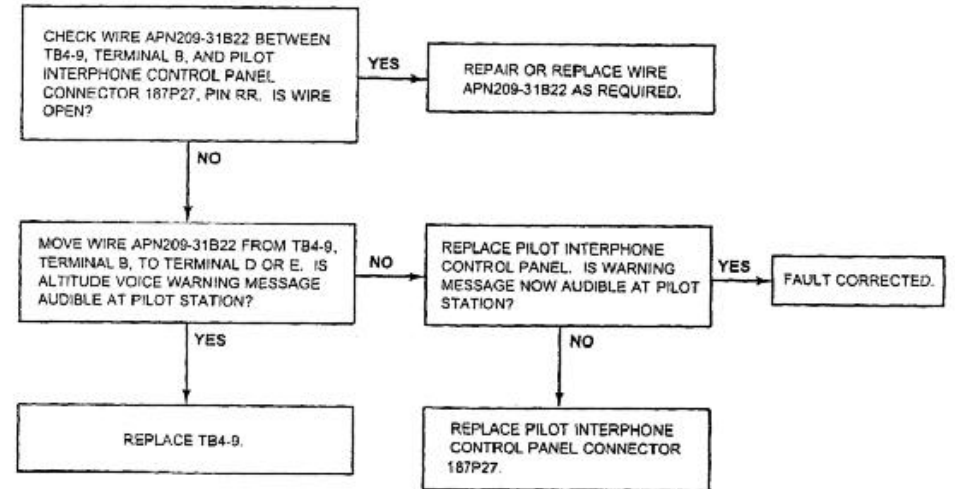

18-2.4 ALTITUDE VOICE WARNING NOT AUDIBLE AT PILOT, COPILOT, OR
AFT STATION/HOIST OPERATOR'S HEADSET WHEN PILOT'S RADAR
ALTIMETER ALTITUDE POINTER IS BELOW OR ABOVE PRESET
ALTITUDE LIMITS (Continued)

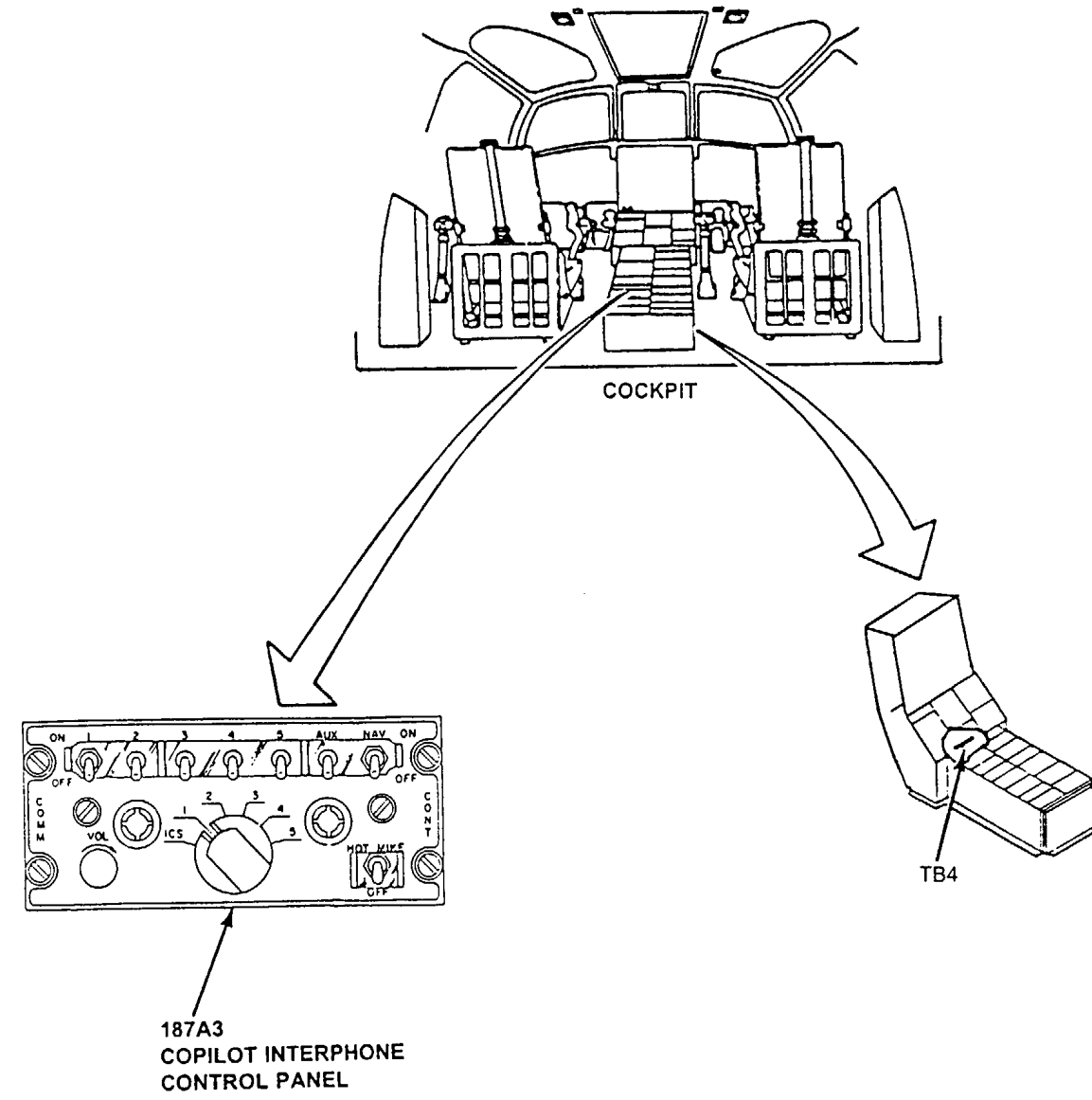
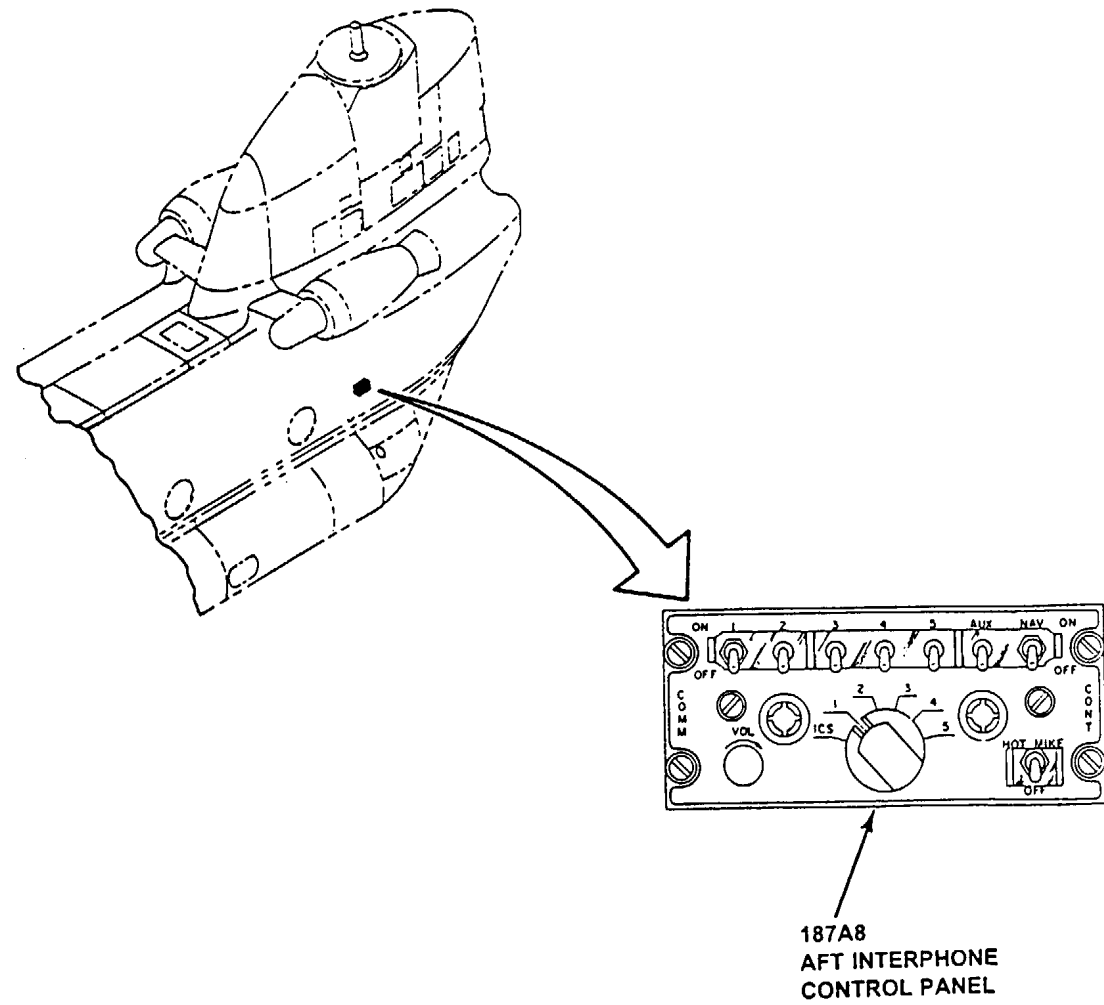

ALTITUDE VOICE WARNING NOT AUDIBLE AT PILOT, COPILOT, OR AFT STATION/HOIST OPERATOR'S HEADSET WHEN PILOT'S RADAR ALTIMETER ALTITUDE POINTER IS BELOW OR ABOVE PRESET ALTITUDE LIMITS (Continued)

ALTITUDE VOICE WARNING NOT AUDIBLE AT COPILOT STATION ONLY.

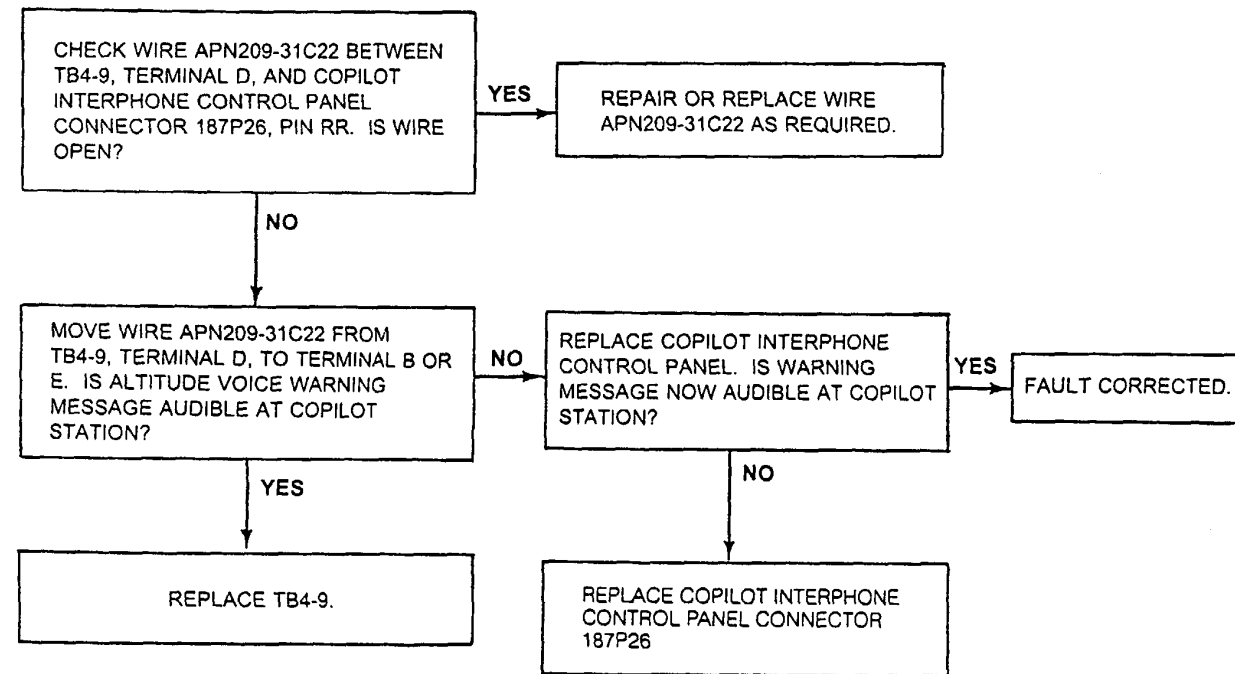

ALTITUDE VOICE WARNING NOT AUDIBLE AT AFT/HOIST OPERATOR STATION ONLY.

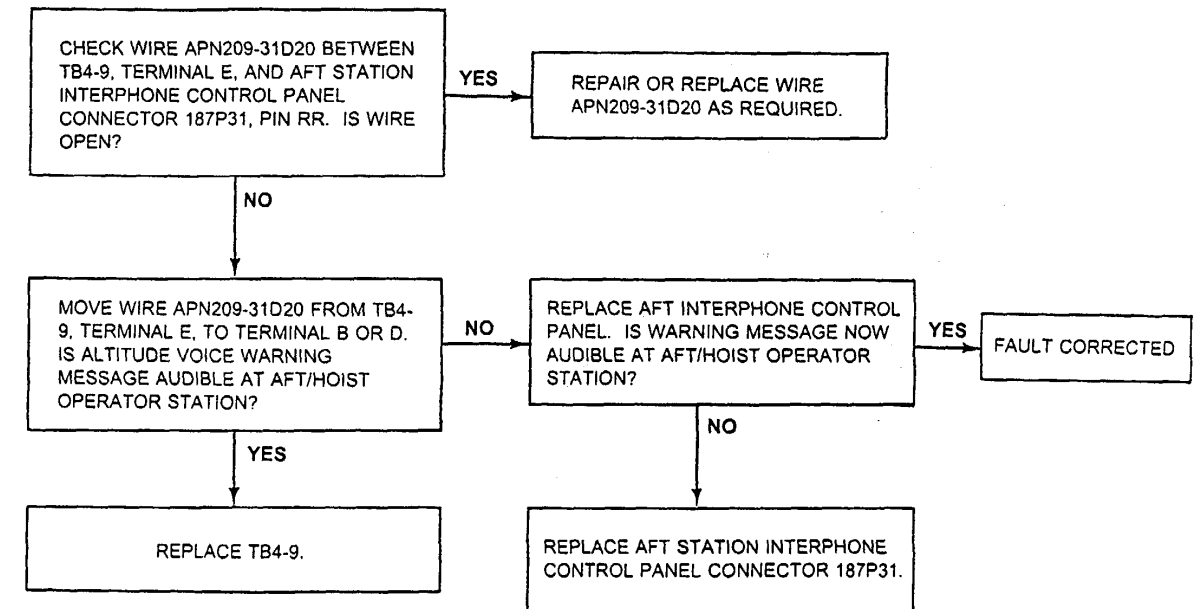

END OF TASK
Change 18 18-57

18-2.5 ALTITUDE VOICE WARNING MESSAGE VOLUME LEVEL DOES NOT FLUCTUATE WHEN PILOT RADAR ALTIMETER PRESS-TO-TEST KNOB IS MOMENTARILY DEPRESSED

REPLACE PILOT'S ALTITUDE VOICE WARNING RADAR ALTIMETER

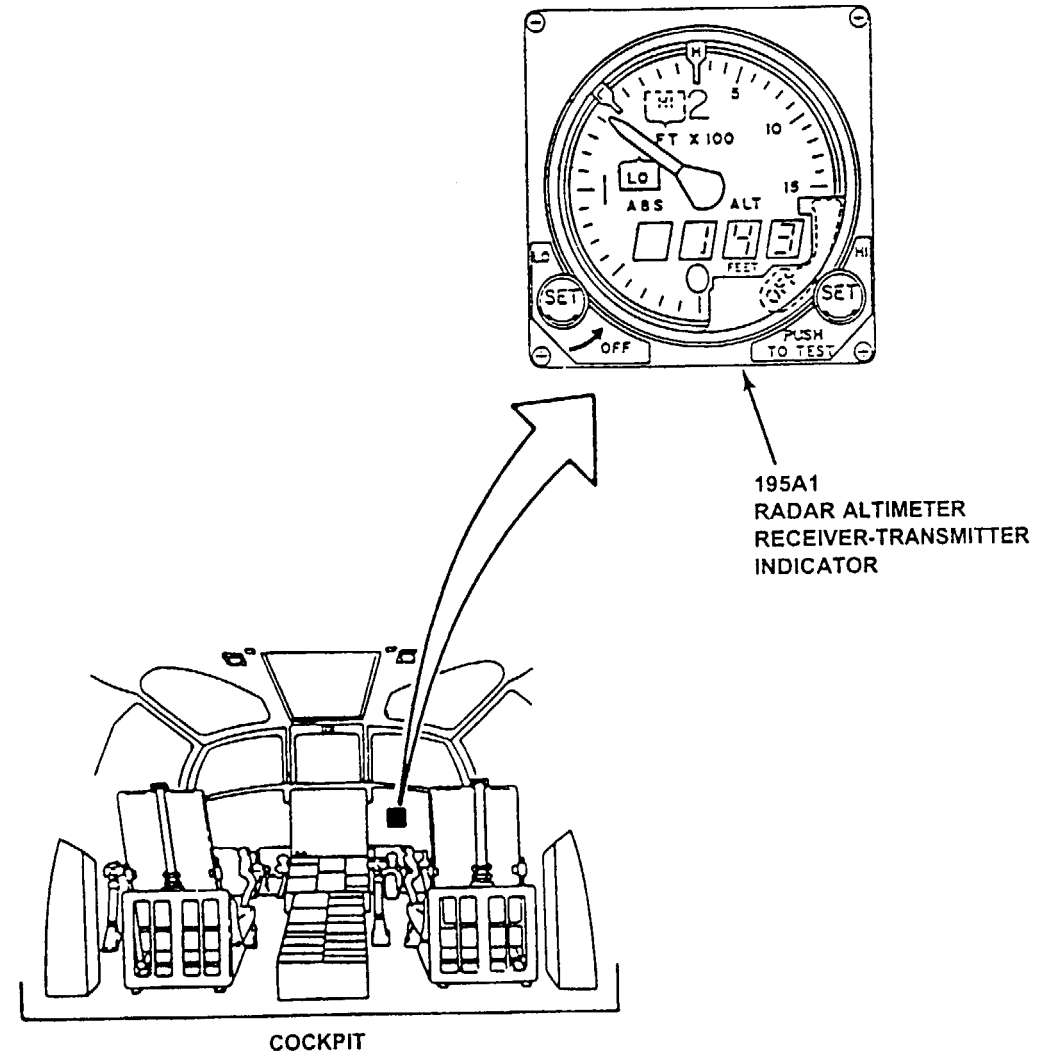

ALTITUDE VOICE WARNING MESSAGE IS AUDIBLE WHEN
ALTITUDE POINTER IS WITHIN THE HI/LO SET INDEX
ENVELOPE

REPLACE PILOT'S ALTITUDE
VOICE WARNING RADAR
ALTIMETER

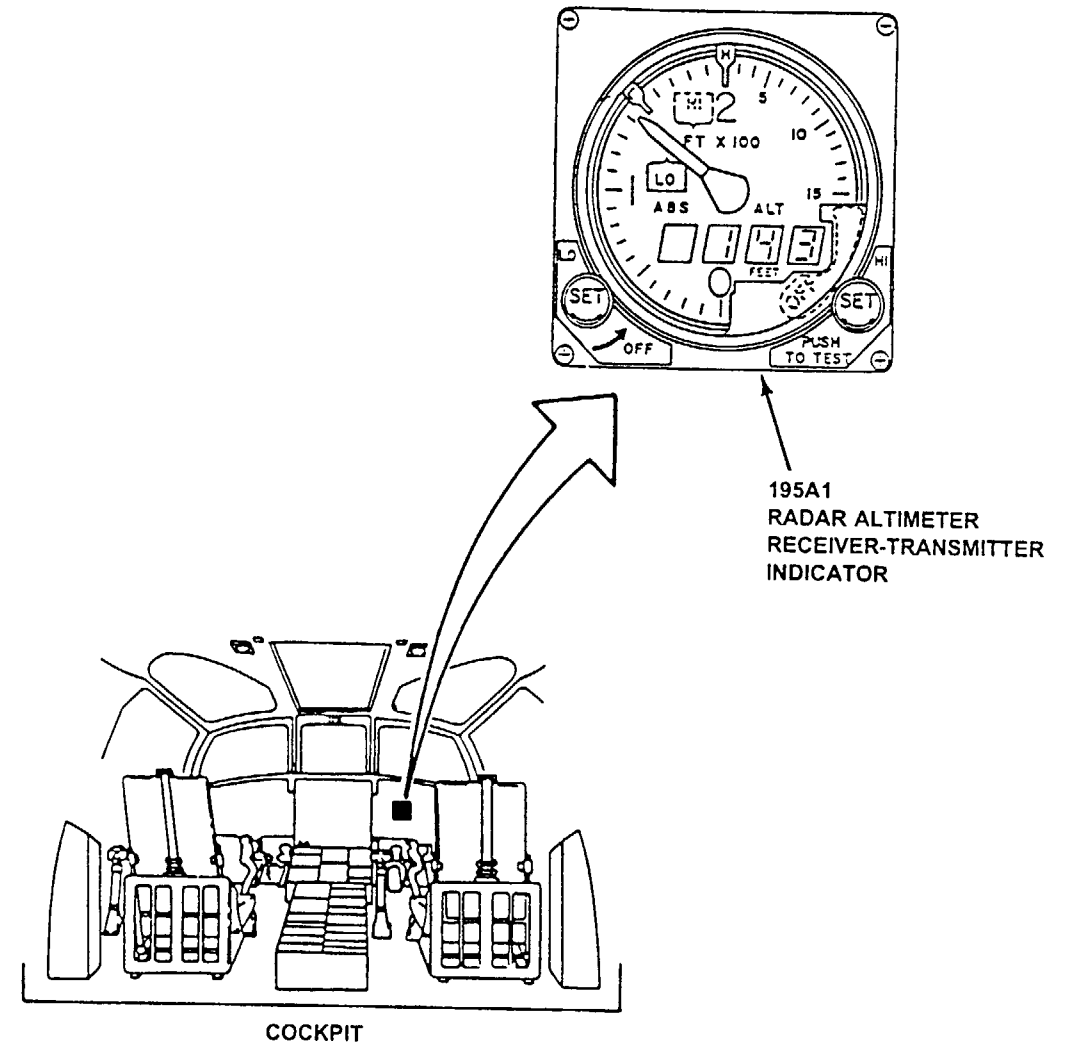

18-3 DOPPLER/GPS NAVIGATION SYSTEM

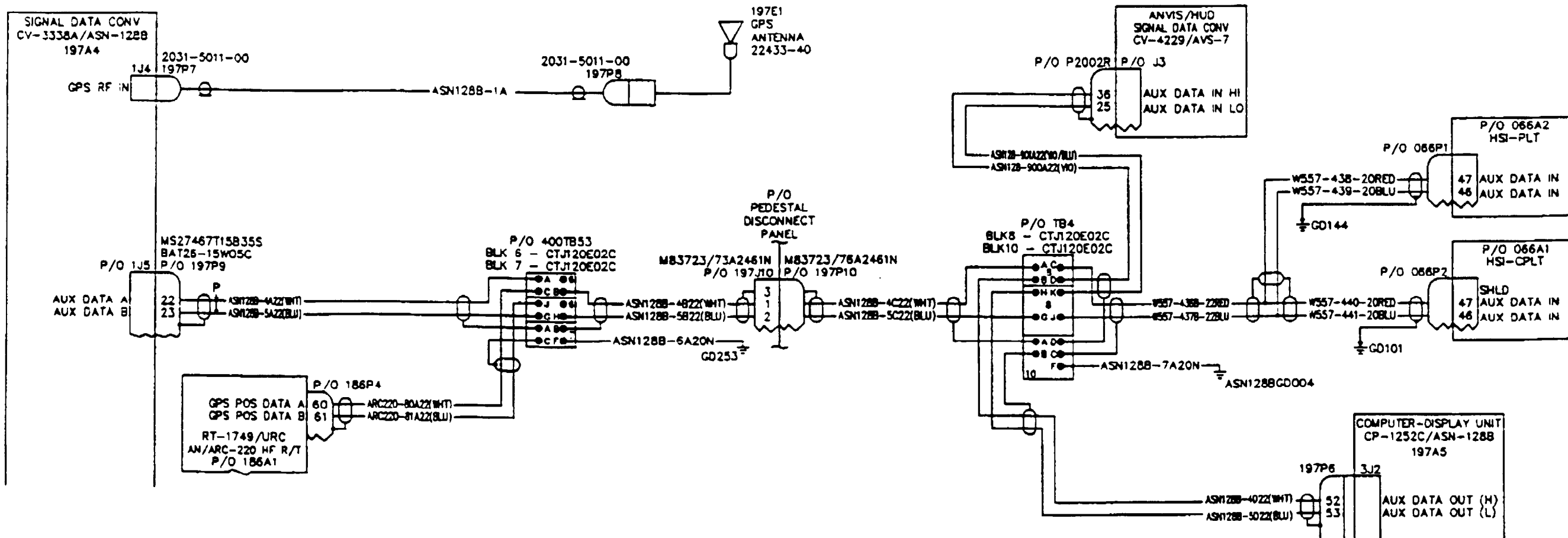

18-3.1 DOPPLER/GPS NAVIGATION SYSTEM WIRING DIAGRAM (Continued)

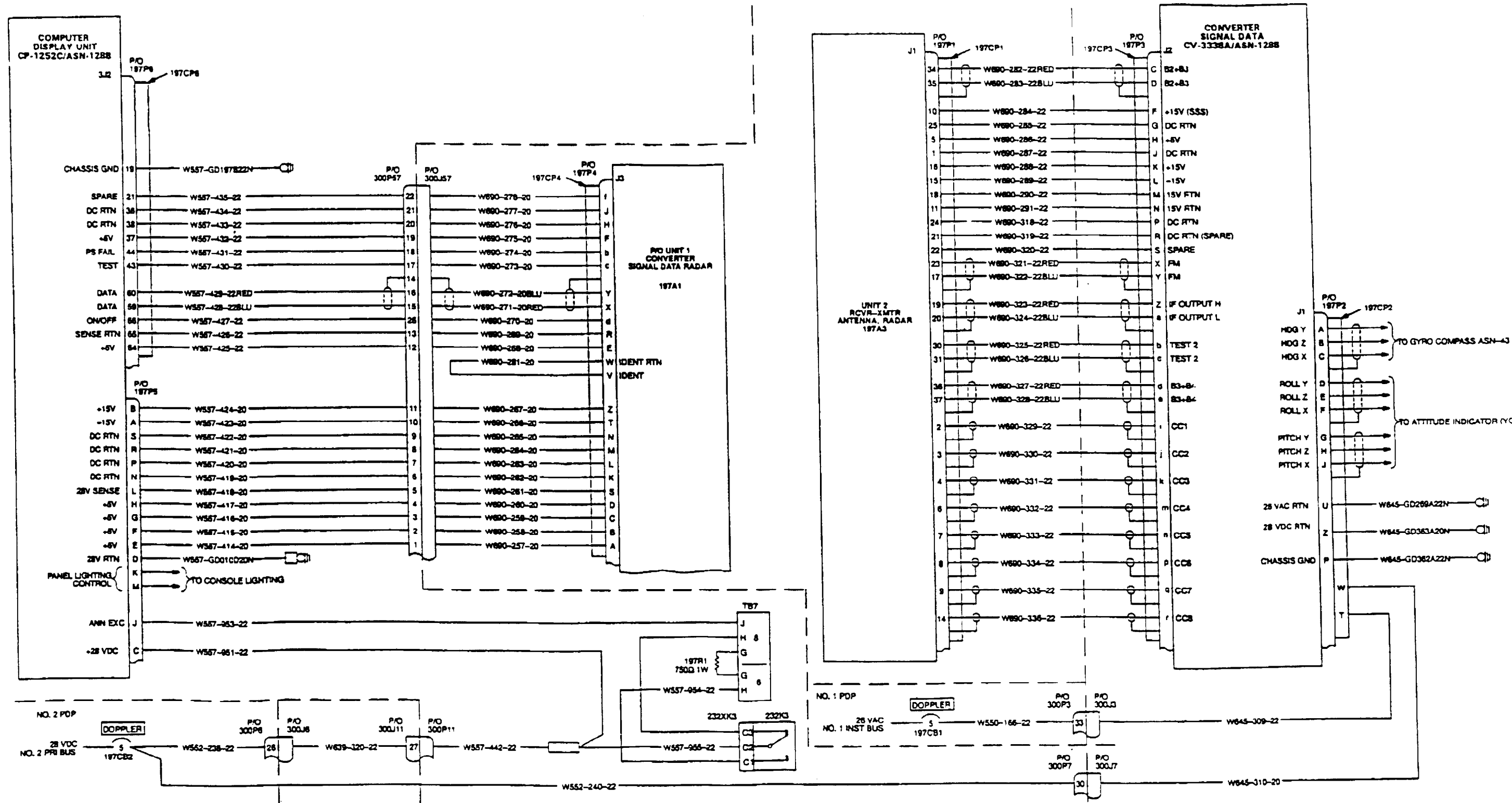

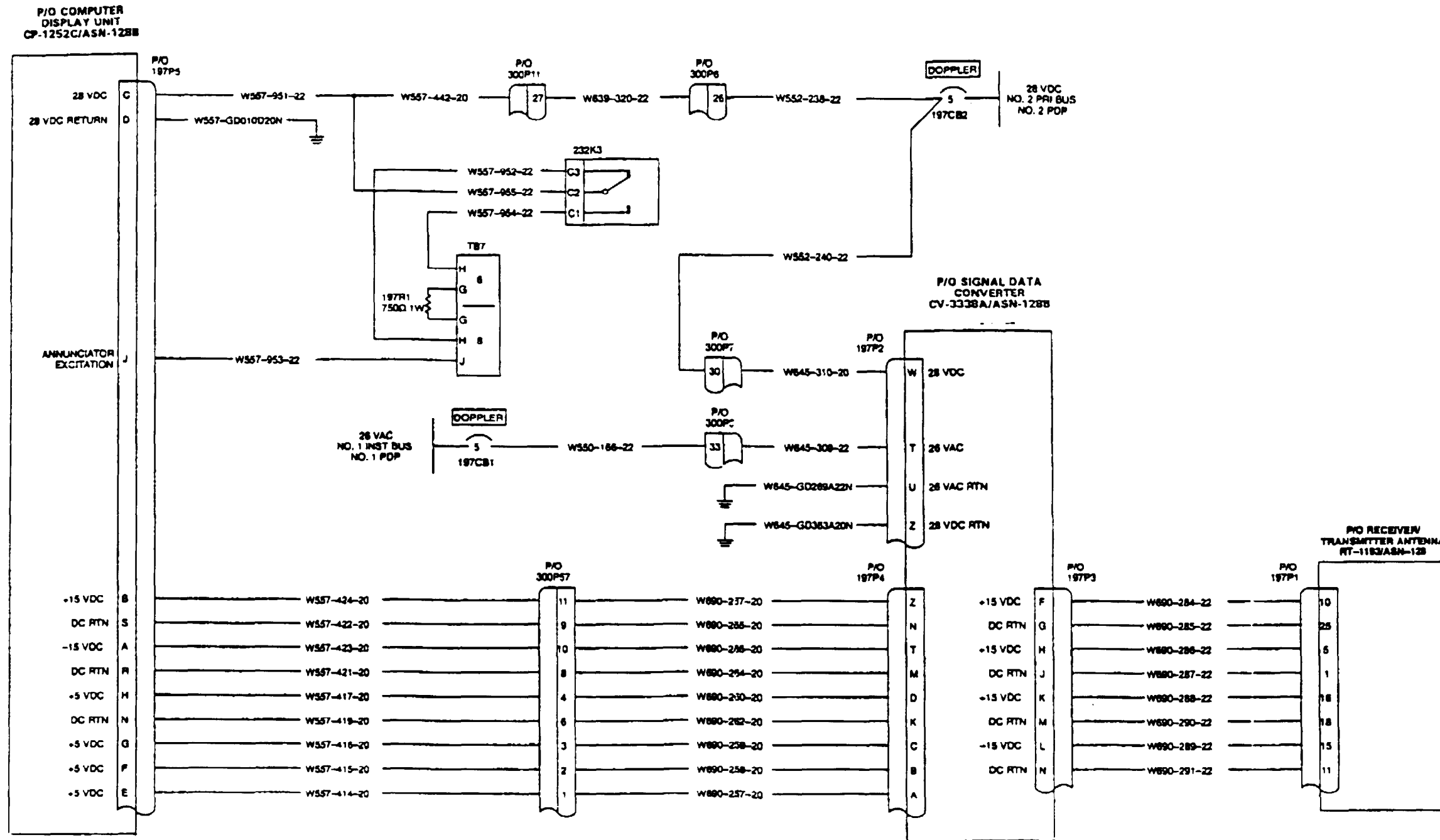

18-3.1 DOPPLER/GPS NAVIGATION SYSTEM WIRING DIAGRAM (Continued)

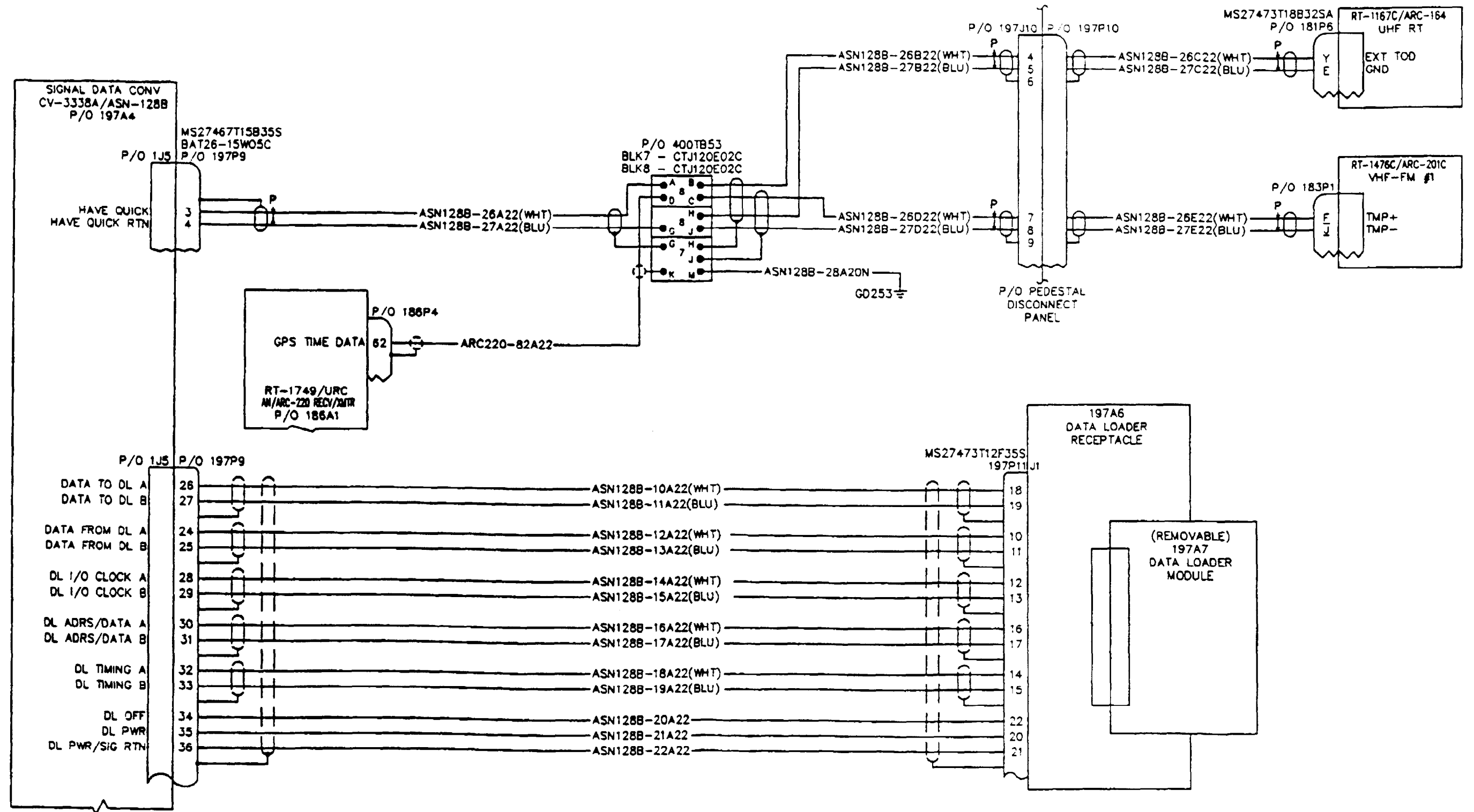

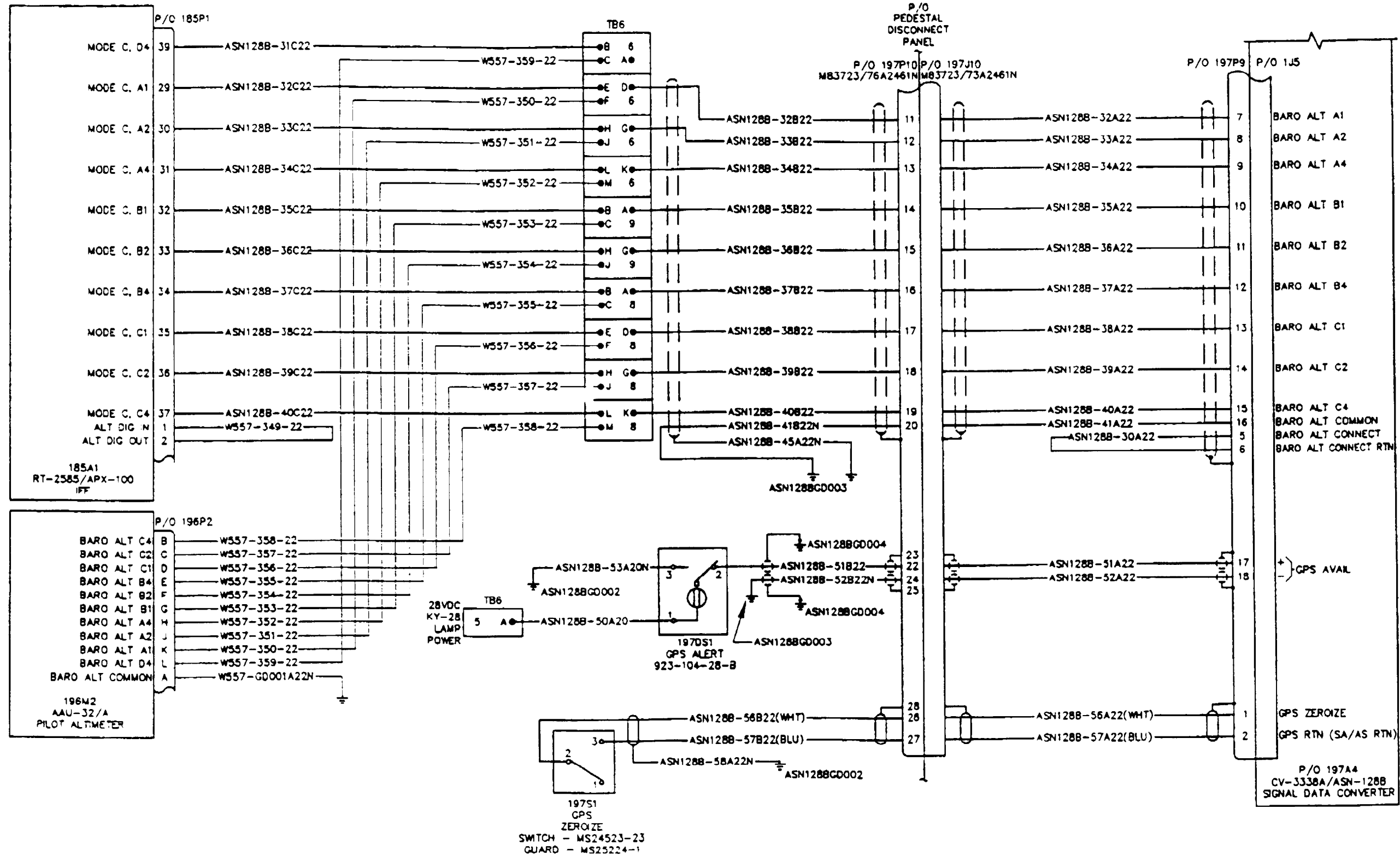

18-3.2 DOPPLER/GPS NAVIGATION SYSTEM VISUAL CHECK

18-3.2

INITIAL SETUP

Applicable Configurations:
All

References:
TM 55-1520-240-23

Tools:
Electrical Repairer's Tool Kit,
NSN 5180-00-323-4915

Equipment Condition:
TM 55-1520-240-23:
Battery Disconnected
Electrical Power Off
No. 2 Access Door (Tunnel Cover)
Open

Materials:
None

Personnel Required:
68F10 Aircraft Electrician

TASK	RESULT
1. Check DGNS CDU (1).	Loosen Dzus fasteners and check rear connectors of DGNS CDU (1). If connectors are loose or damaged tighten or replace it as required. If wiring to connector is loose or damaged, tighten, repair, or replace it as required. If display screen is damaged in any way replace CDU (1). If knobs are loose or broken tighten or replace as required. If pushbuttons are damaged replace CDU (1). Reinstall CDU (1) in the canted console tightening the Dzus fasteners.
2. Check GPS Alert Light Indicator (2).	If indicator (2) is loose or damaged tighten or replace as required.
3. Check GPS Zeroize Switch/Cover (3).	If switch or cover (3) is loose or damaged tighten or replace as required. If wiring to switch is loose or broken tighten, repair, or replace as required.
4. Check GPS/DOP SEL Indicator (4).	If indicator lens (4) is damaged replace.
5. Check DOPPLER Circuit Breakers (5).	If breakers (5) are loose or damaged tighten or replace as required. If wiring to breaker is loose or broken tighten, repair, or replace as required.
6. Check RADAR Signal Data Converter CV-3338A/ASN-128B (SDC) (6).	If SDC (6) is loose or damaged tighten or replace as required. If connectors to the SDC are loose or damaged tighten or replace as required. If wiring or cables to SDC are loose or damaged tighten, repair, or replace as required.

TASK	RESULT
7. Check GPS Data Loader Receptacle (7).	If receptacle (7) is loose or damaged tighten or replace as required. If pushbutton is loose or damaged replace Data Loader Receptacle. If the connector to the receptacle is loose or damaged tighten or replace as required. If wiring to the connector is loose or damaged tighten, repair, or replace as required.
8. Check GPS Antenna (8).	If antenna (8) is loose or damaged tighten or replace as required. If cable (9) to antenna is loose or broken tighten or replace as required. DO NOT REPAIR THIS CABLE.

FOLLOW-ON MAINTENANCE:
Close No. 2 Access Door (Tunnel Cover)

GO TO NEXT PAGE

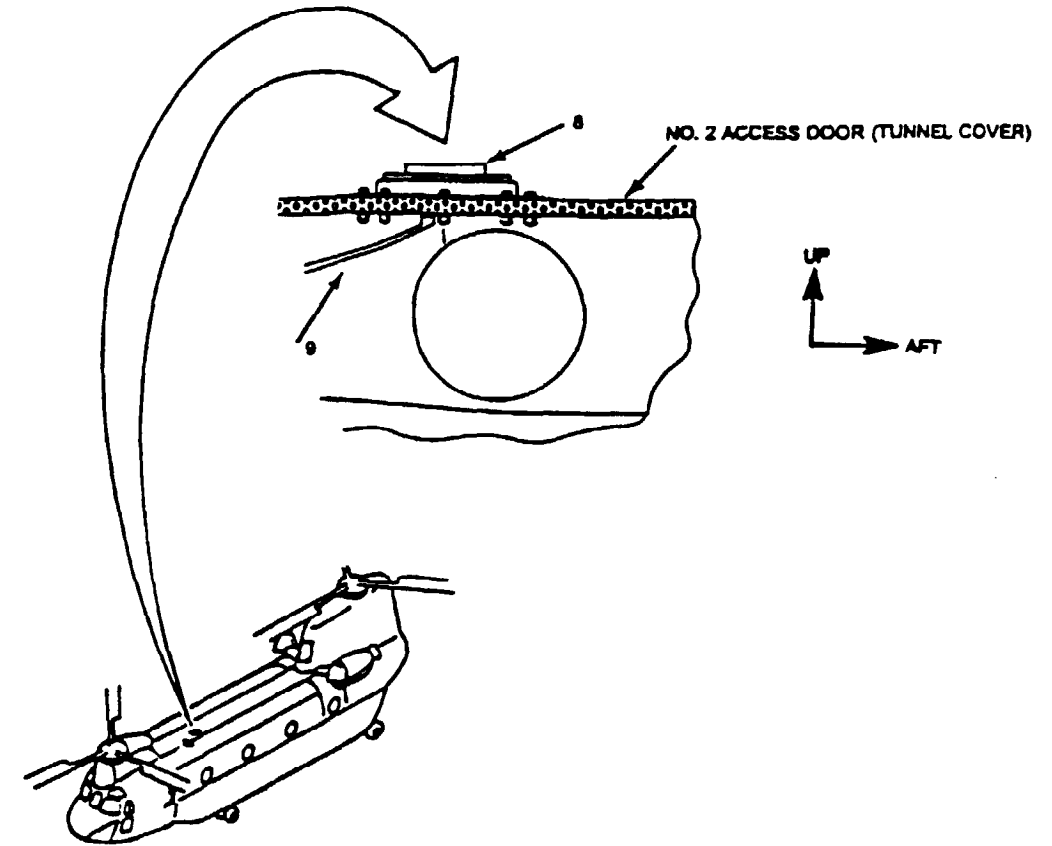
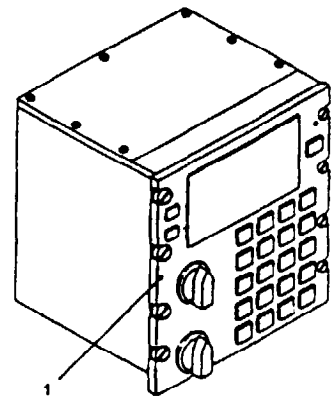
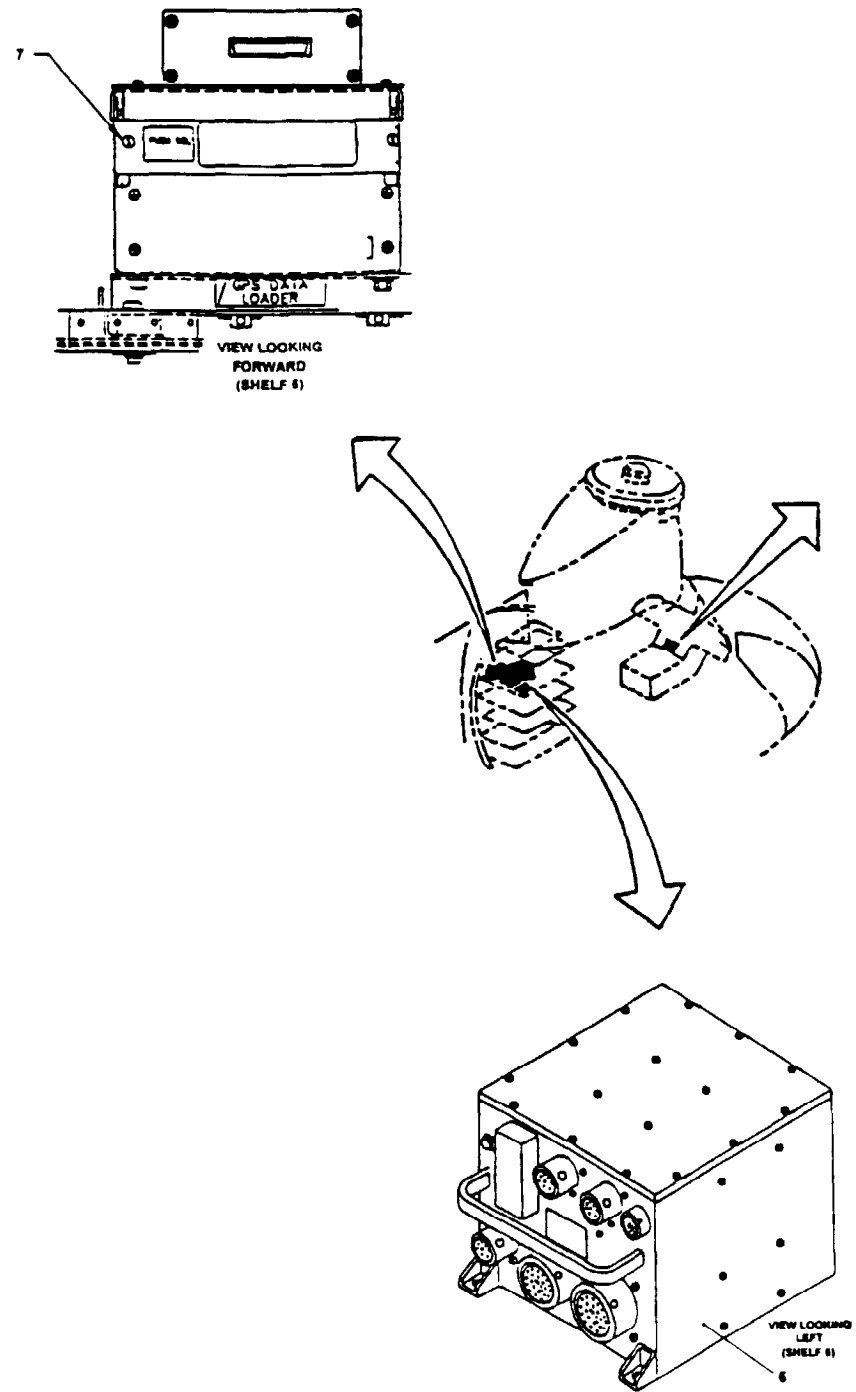

GO TO NEXT PAGE

18-3.2 DOPPLER/GPS NAVIGATION SYSTEM VISUAL CHECK (Continued)

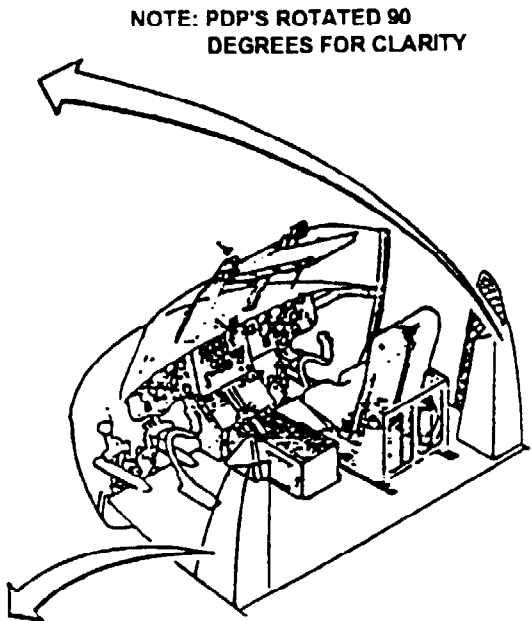
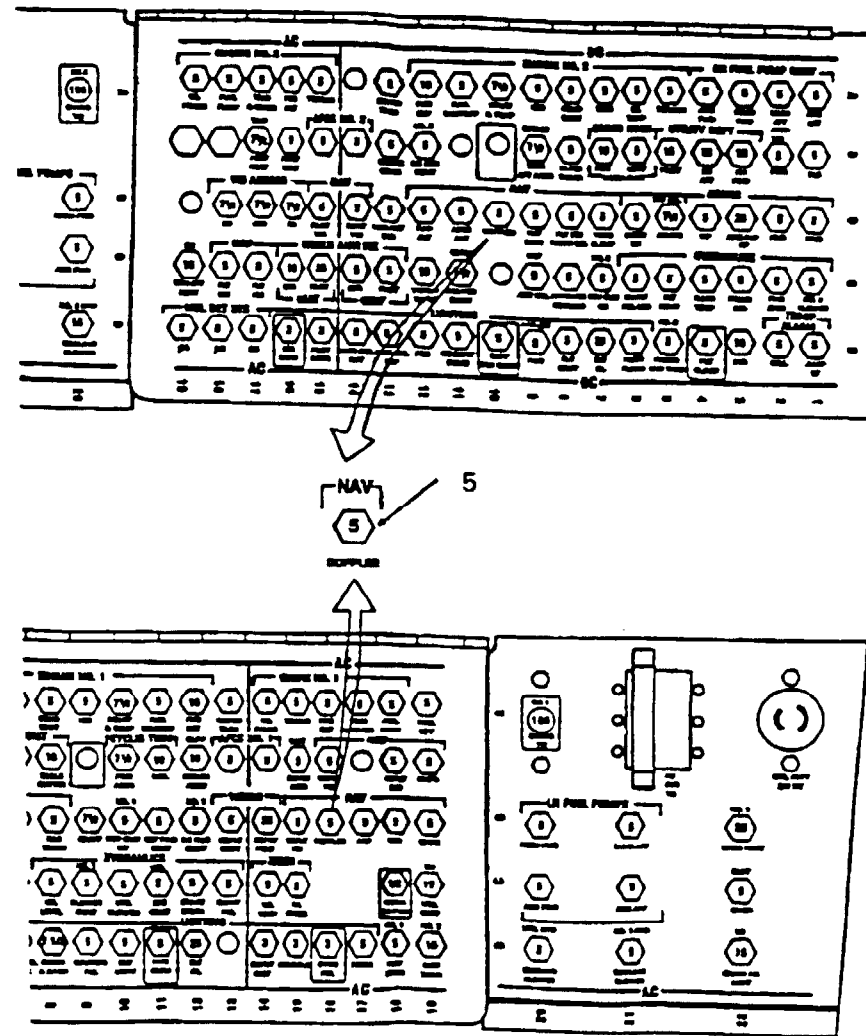
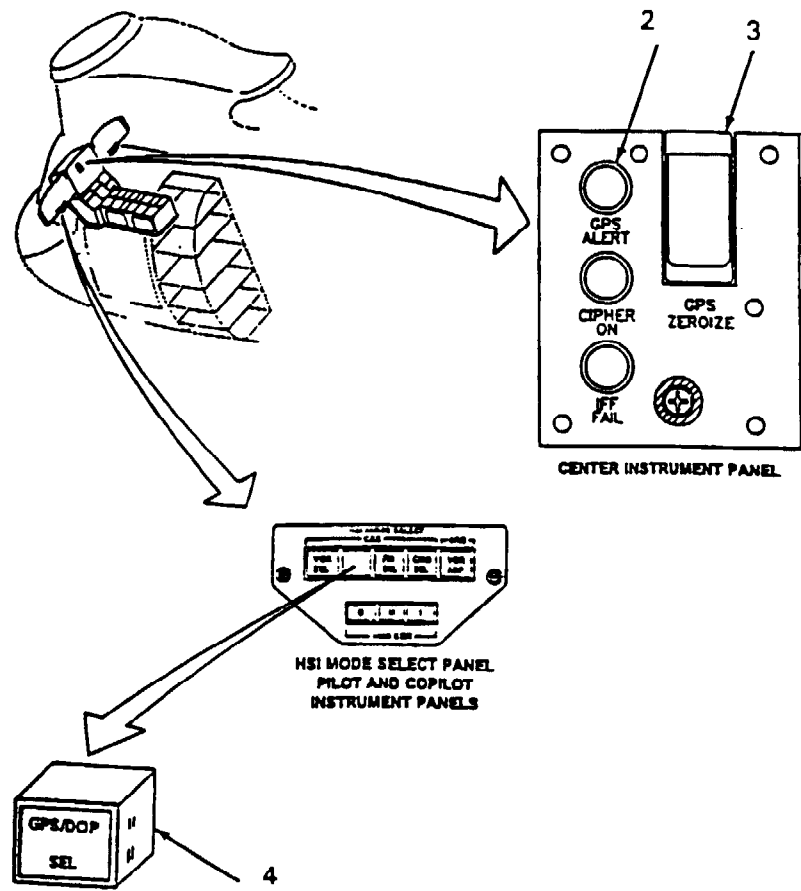

END OF TASK

18-3.3 DOPPLER/GPS NAVIGATION SYSTEM OPERATIONAL CHECK

INITIAL SETUP

Applicable Configurations:

All

References:

- TM 11-1520-240-23
- TM 11-5841-305-12
- TM 55-1520-240-23

Tools:

Electrical Repairer's Tool Kit,
NSN 5180-00-323-4915

Equipment Condition:

- TM 55-1520-240-23:
- Battery Connected
- Electrical Power Off
- Hydraulic Power Off
- Doppler/GPS Navigation System Visual Check Performed (Task 18-3.2)

Materials:

None

Personnel Required:

Aircraft Electrician (2)

TASK	RESULT
------	--------

NOTE

Remove aircraft from overhead cover.

CHECK CIRCUIT BREAKERS

1. **Check that DOPPLER breakers (1) on No. 1 and 2 pdp are closed.** If circuit breakers are open, close them.
2. **Start APU.** Refer to task 15-1.4. APU ON capsule shall come on.

CHECK DGNS LIGHTING

3. **Turn aircraft CTR CSL LTG control (2) clockwise and counterclockwise while checking CDU (3) Edge lighting is illuminated and all keyboard keys are illuminated.** CDU (3) panel Edge light and all keyboard lights shall vary with the changing setting of the aircraft dimmer control (2). If CDU (3) panel Edge and keyboard lights are not visible or intensity level does not vary with aircraft dimmer control (2) go to task 18-3.4
4. **Set CDU (3) MODE switch (4) to LAMP TEST. Enter GPS mode "M". Verify that MAL LAMP and all LED segments on four-line display are illuminated.** CDU MAL LAMP and all LED segments on four-line display are illuminated. If CDU MAL LAMP and all LED segments are not illuminated go to task 18-3.5.
5. **Press CDU (3) DIM (5) pushbutton several times, the BRT (6) pushbutton several times.** The LED display will grow dimmer then brighten. If the intensity of the LED display does not vary replace CDU.

TASK	RESULT
------	--------

6. **Set CDU (3) MODE switch (4) to TEST.** After Doppler and/or GPS self tests have been completed (approximately 15 seconds for Doppler, up to 2 minutes for GPS) one of the following indications will be observed in left and right displays. If the display is not GO ALL go to task 18-3.6.

NOTE

In the event TEST mode display is not GO ALL the system should be recycled through OFF to verify that the failure is not momentary one.

LEFT DISPLAY	RIGHT DISPLAY	REMARKS
GO		Doppler has completed Built In Test (BIT) and is operating satisfactorily, GPS is still performing BIT (GPS has a 2 minute BIT cycle maximum). Note that a rotating bar in the display indicates that the GPS is still performing self test.
GO	ALL	The entire system has completed BIT and is operating satisfactorily.
GO	P	Pitch or Roll data is missing or exceeds 90 degrees. In this case, pitch and roll in the computer are both set to zero and navigation in the Doppler mode continues with degraded operation. Problem may be in the vertical gyro or aircraft cabling.
NG	C, R, S or H followed by a numeric code	A failure has occurred in the Computer Display Unit or the Signal Data Converter Power Supply. The operator should not use the System.
DN	GPS failure code	GPS has failed but operator can use Doppler to perform all navigation.
DF	Doppler failure code	Doppler has failed. GPS is still performing self test.
GN	Doppler failure code	Doppler has failed but operator can use GPS to perform all code navigation.

GO TO NEXT PAGE

18-3.3 DOPPLER/GPS NAVIGATION SYSTEM OPERATIONAL CHECK (Continued)

TASK	RESULT
7. Depress GPS Alert Indicator (7).	GPS Alert Indicator (6) illuminates. If indicator does not illuminate, go to task 18-3.7.
8. Place CDU DISPLAY switch (9) to PP.	Present position is displayed. If present position is not displayed, go to task 18-3.8.
9. Perform the following for downloading of waypoints from Data Loader Cartridge: <ul style="list-style-type: none"> a. Place CDU (3) MODE switch (4) to OFF b. Insert a programmed Data Loader in Receptacle (8). c. Set CDU Mode switch to MGRS. d. Make sure Mode of the GPS is in M. e. Set CDU Display switch to WIND UTC/DATA. f. Depress ENT twice to display the selection menu. g. Enter 4 to select the data load page. h. To begin downloading, depress KYBD and enter "Y" (yes). 	CDU (3) displays DOWNLOAD WAYPTS IN PROCESS and WAIT ACK during waypoint loading and DOWNLOAD WAYPTS COMPLETE within one minute to indicate that waypoint loading is complete. If display is incorrect go to task 18-3.9.
10. Turn CDU (3) MODE switch (4) to OFF, remove Data loader cartridge from the receptacle and turn the MODE switch (4) to MGRS.	
11. Turn CDU (3) DISPLAY switch to (9) DIST/BRG/TIME and select several waypoints.	The four-line display will display distance, bearing and time information for each waypoint. If any four-line display is incorrect, replace the CDU.
12. Depress the GPS/DOP lenses (10) on each of the two HSI Mode Select Panels (11) (one each in pilot and copilot Instrument panels).	The SEL indication at the lower half of each GPS/DOP (8) lens shall be illuminated. If SEL not illuminated, go to TM 11-1520-240-23.
13. Observe each HSI (12).	The number one needle (13) of each HSI indicator (12) shall swing to show the bearing to the station with the course deviation bar (14) centered. The Range (15) and Course (16) readouts shall also be accurate. If the number one needle (13) does not swing to show bearing to the station or the Range (15) and Course (16) readouts are not accurate, go to TM 11-1520-240-23.

TASK	RESULT
14. Observe each HSI (12) and four-line display on the CDU (3).	The indications on the four-line display and each HSI are the same. If the indications are not the same, go to task 18-3.10.
15. In the center instrument panel switch GPS ZEROIZE switch (17) up then down. On the CDU (3) set DISPLAY switch to DIST/BRG/TIME and observe the four-line display.	All waypoints have disappeared. If waypoints have not disappeared, go to task 18-3.11.
16. Reperform steps 8, 9 and 10 above.	This task shows that the system is functional and ready. If waypoints could not be downloaded, go to task 18-3.9.
17. Perform HAVEQUICK checks on the HF, UHF and SINGARS Radio Sets.	The Radio Sets have HAVEQUICK Timing. If any or all Radio Sets do not have HAVEQUICK Timing go to task 18-3.12
18. Turn CDU (3) MODE switch (4) to OFF.	The Doppler/GPS Navigation System is off.
19. Stop APU. Refer to task 15-1.4.	

FOLLOW-ON MAINTENANCE:
 TM 55-1520-240-23:
 Battery Disconnected
 Electrical Power Off

GO TO NEXT PAGE

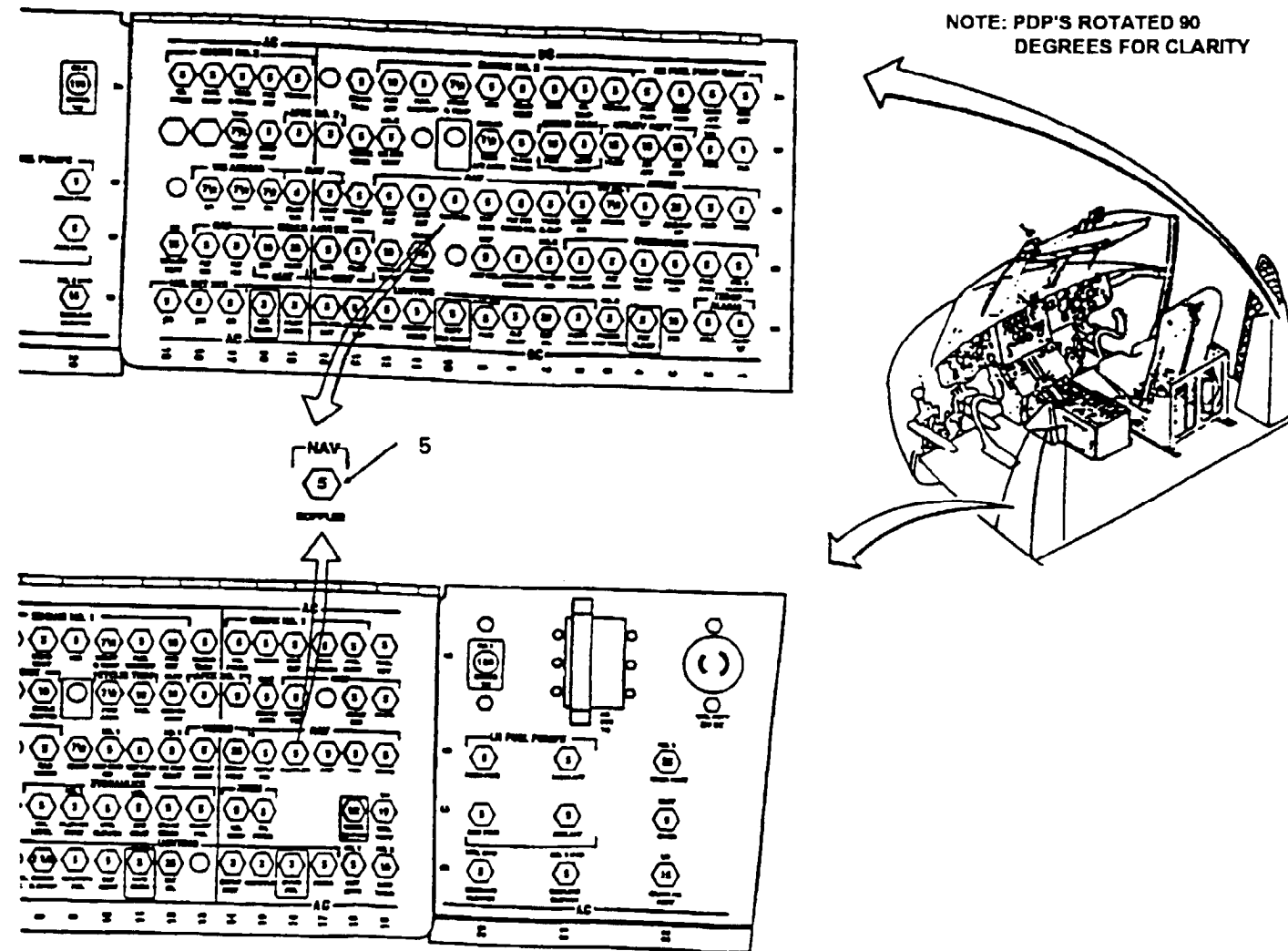

GO TO NEXT PAGE

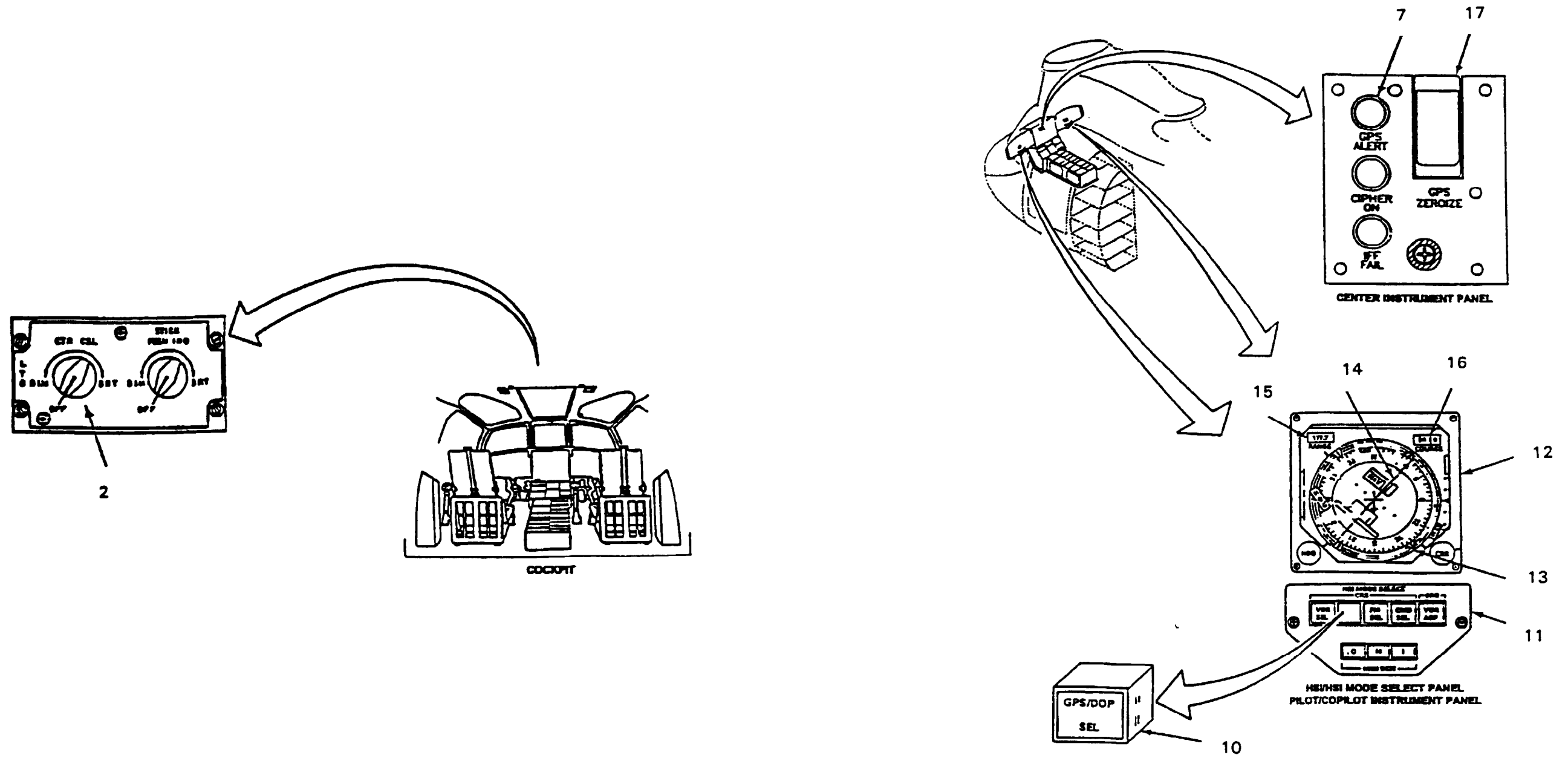

GO TO NEXT PAGE

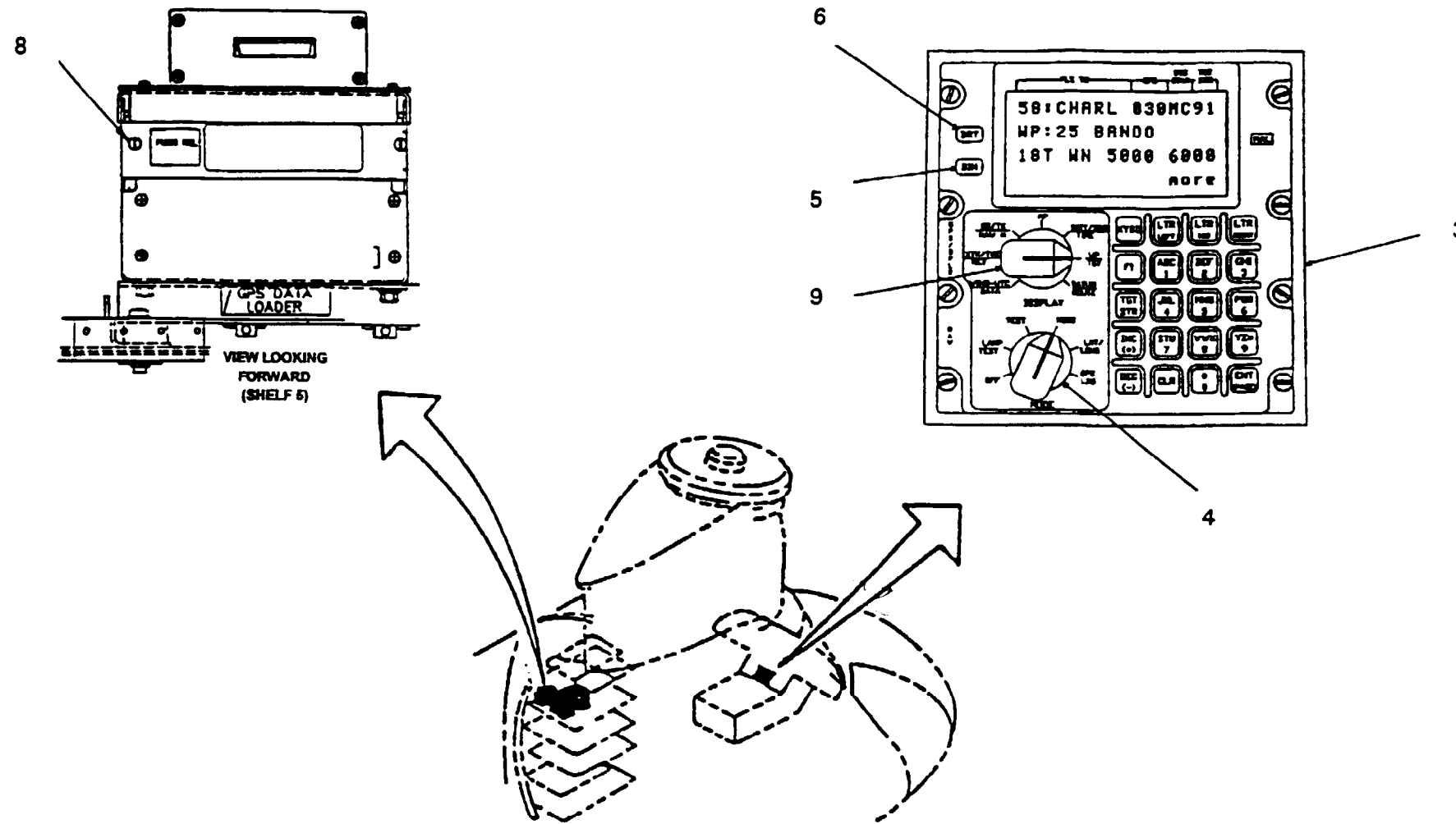

END OF TASK

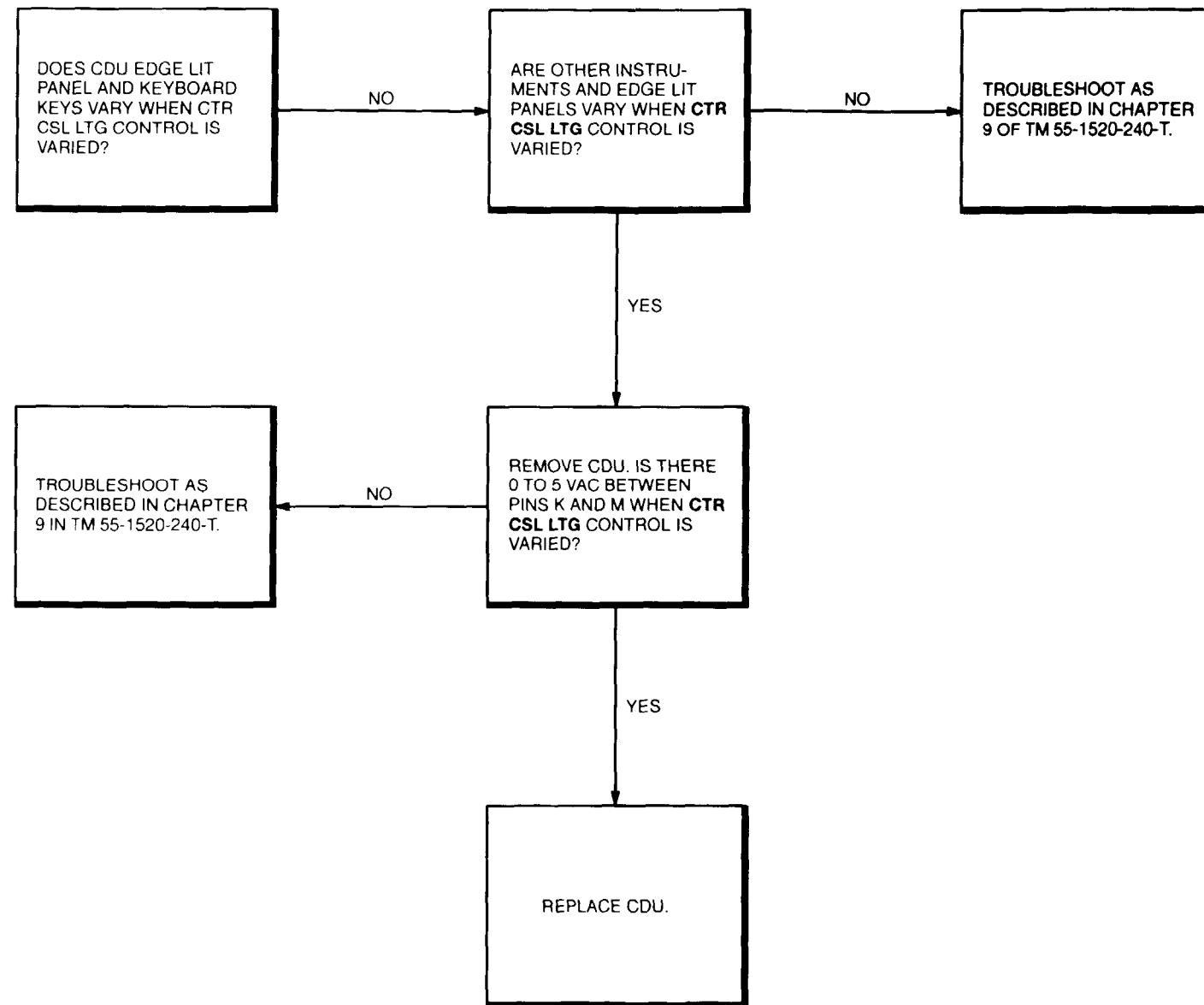

END OF TASK

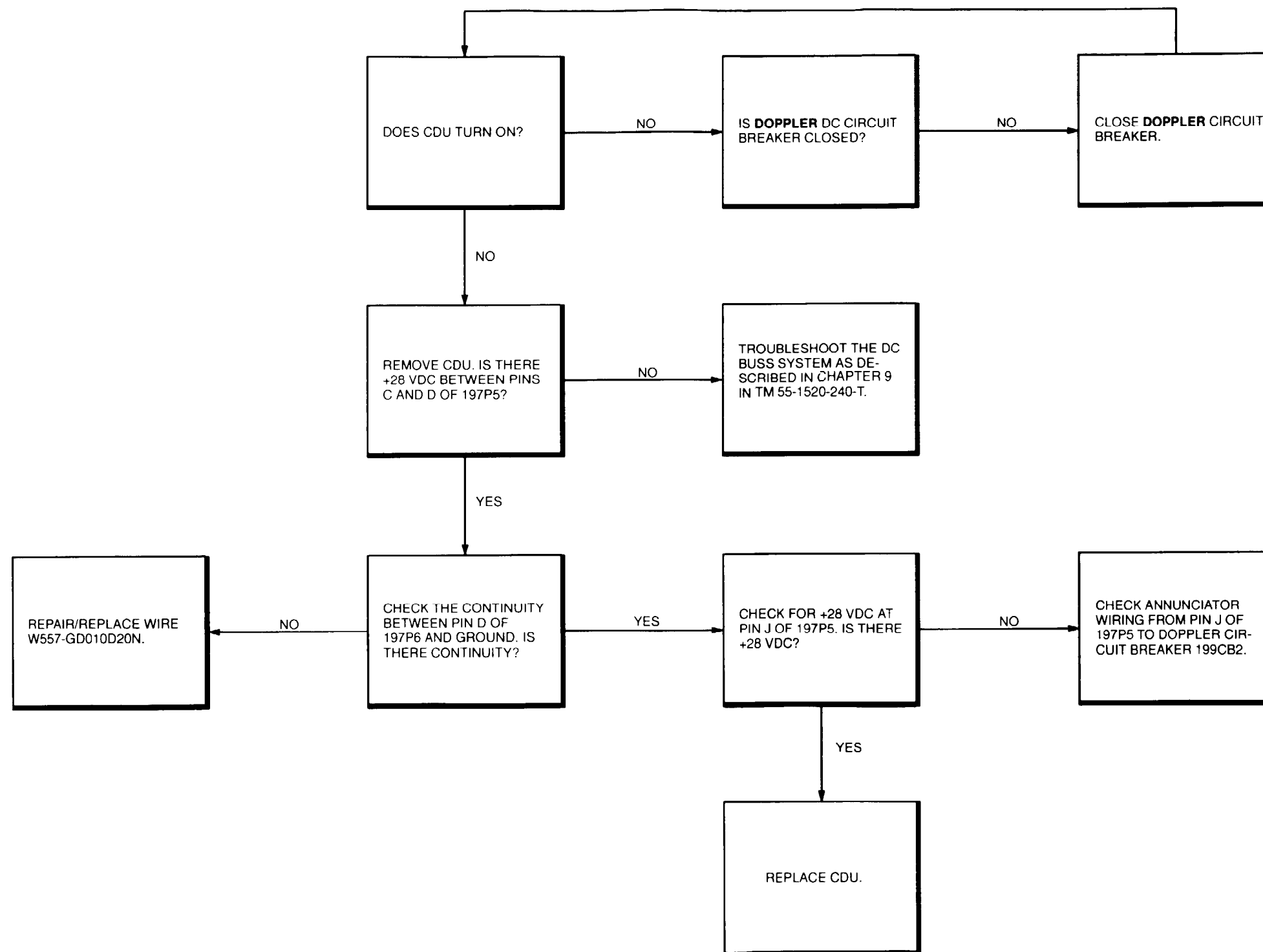

END OF TASK

18-3.6 CDU DISPLAY IS NOT GO ALL

FAULT ISOLATION PROCEDURES

INITIAL SETUP

Applicable Configurations:

All

References:

- TM 11-1520-240-23
- TM 11-5841-305-12
- TM 55-1520-240-23

Tools:

Electrical Repairer's Tool Kit,
NSN 5180-00-323-4915

Equipment Condition:

- TM 55-1520-240-23:
- Battery Connected
- Electrical Power On
- Hydraulic Power Off

Materials:

None

Personnel Required:

Aircraft Electrician

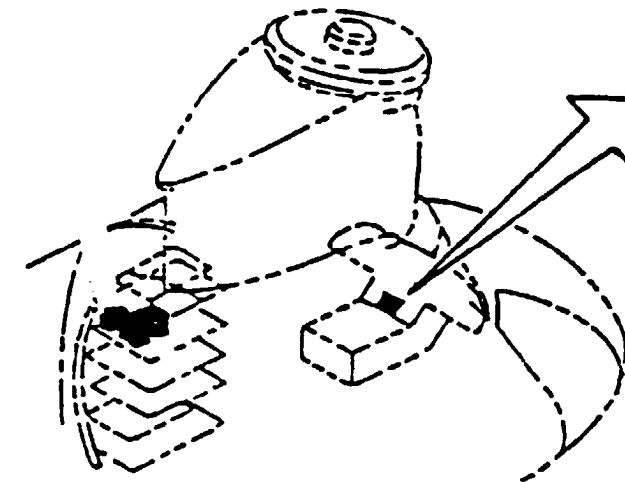
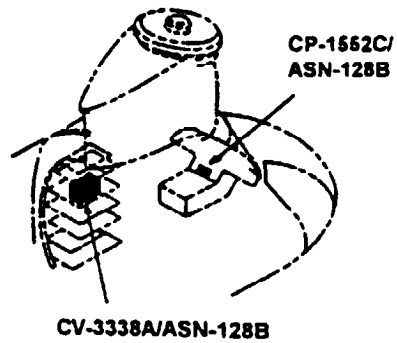
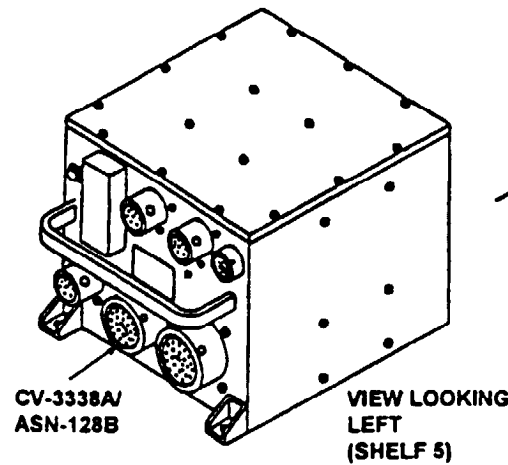
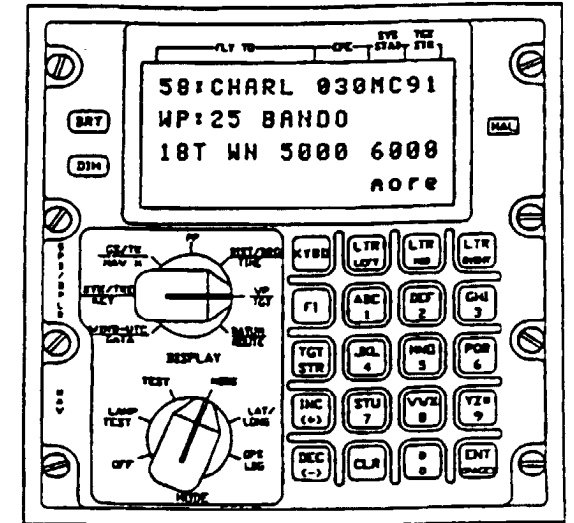

GO TO NEXT PAGE

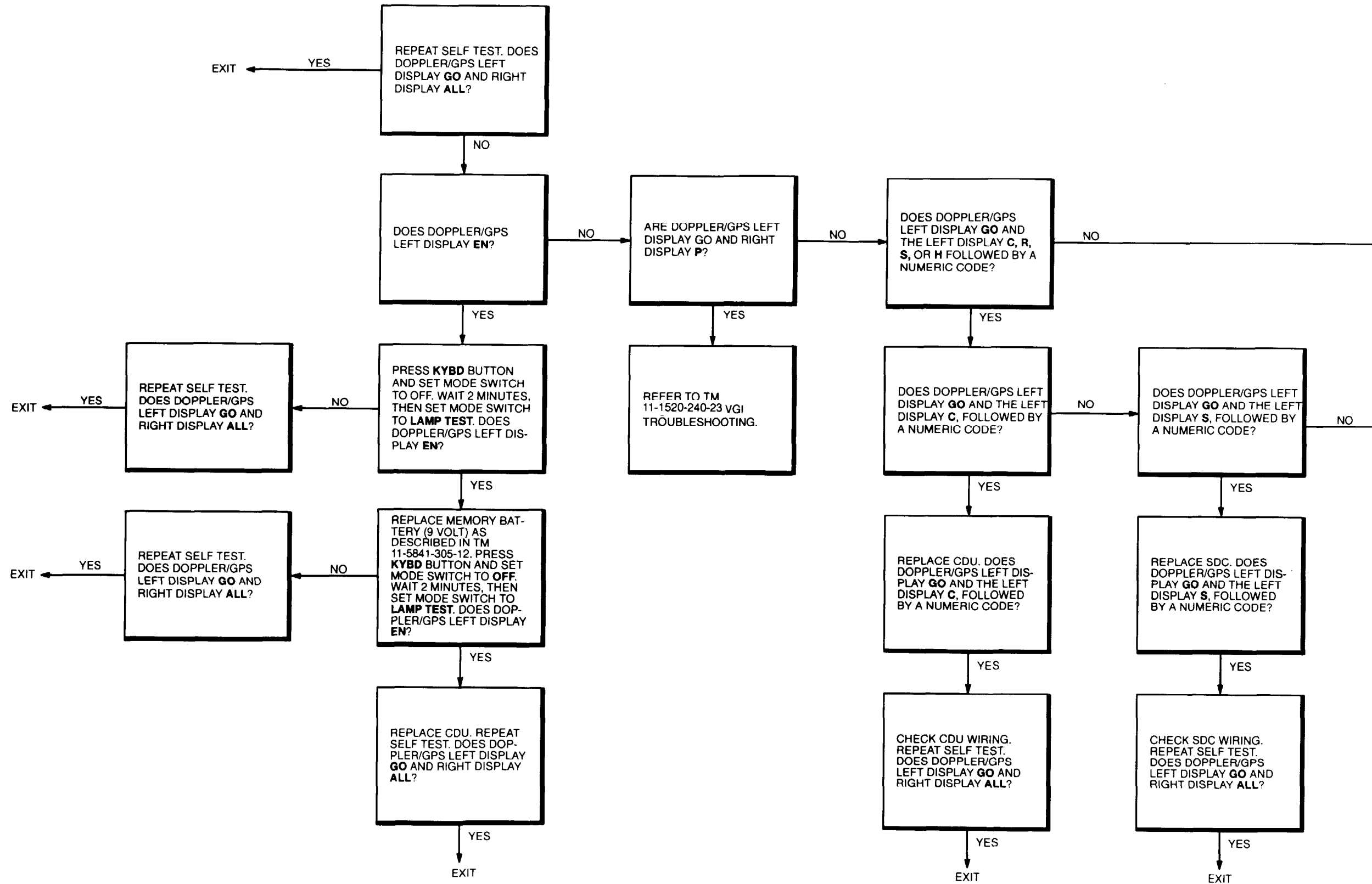

GO TO NEXT PAGE

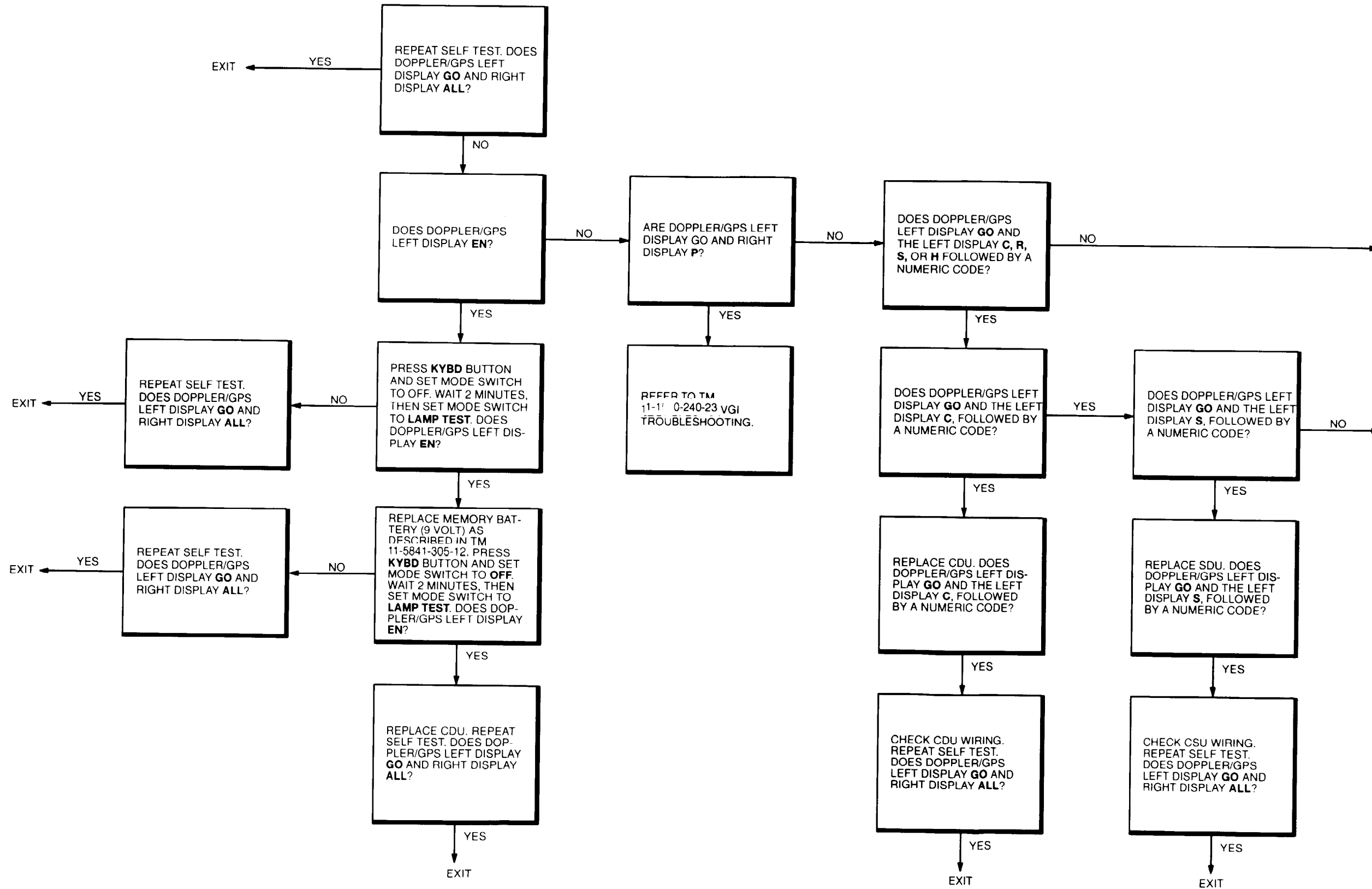

GO TO NEXT PAGE

18-3.6 CDU DISPLAY IS NOT GO ALL (Continued)

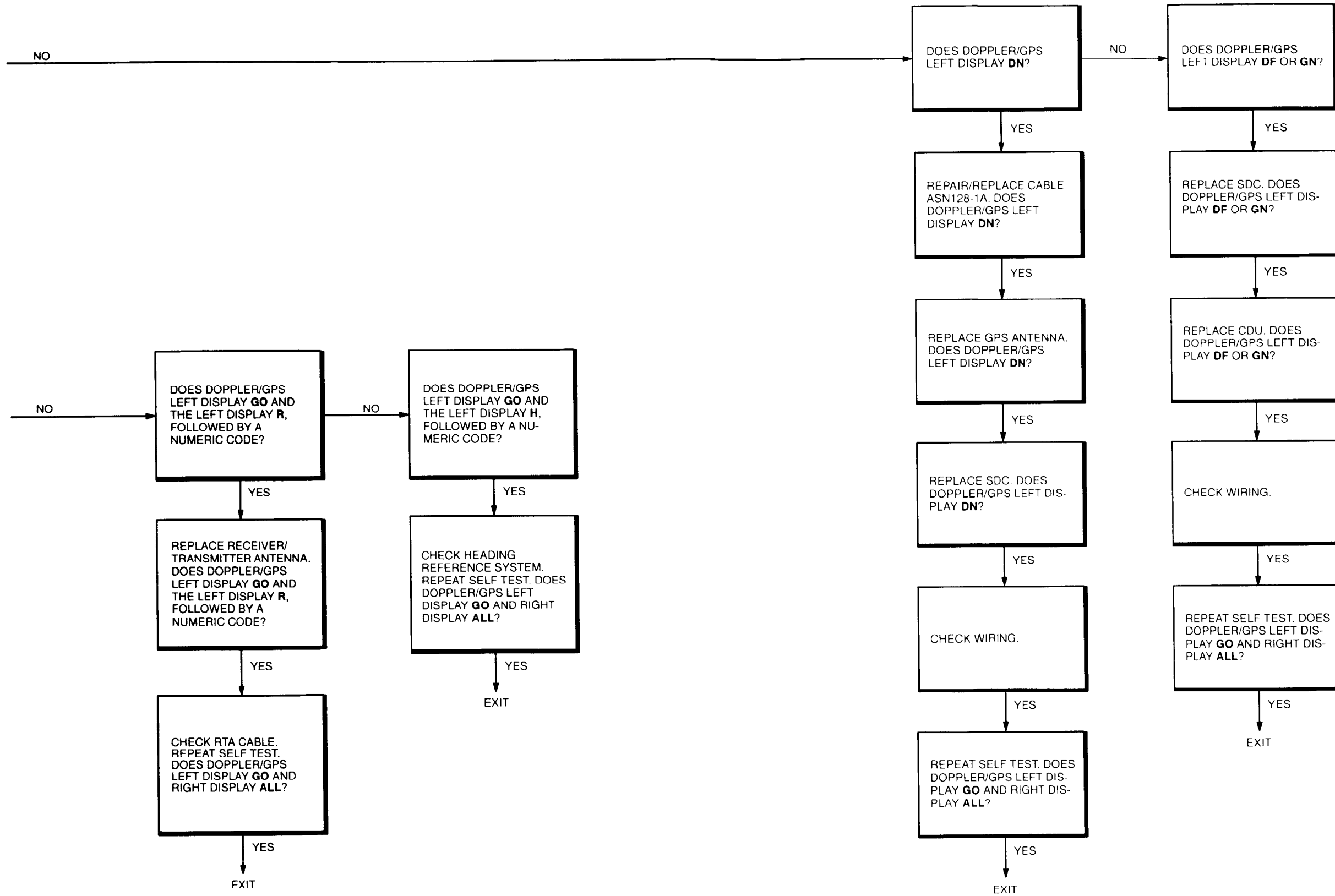

END OF TASK

18-3.7 GPS ALERT INDICATOR DOES NOT ILLUMINATE

FAULT ISOLATION PROCEDURES

INITIAL SETUP

Applicable Configurations:

All

References:

TM 11-1520-240-23

TM 11-5841-305-12

TM 55-1520-240-23

Tools:

Electrical Repairer's Tool Kit,
NSN 5180-00-323-4915

Equipment Condition:

TM 55-1520-240-23:

Battery Connected

Electrical Power On

Hydraulic Power Off

Materials:

None

Personnel Required:

Aircraft Electrician

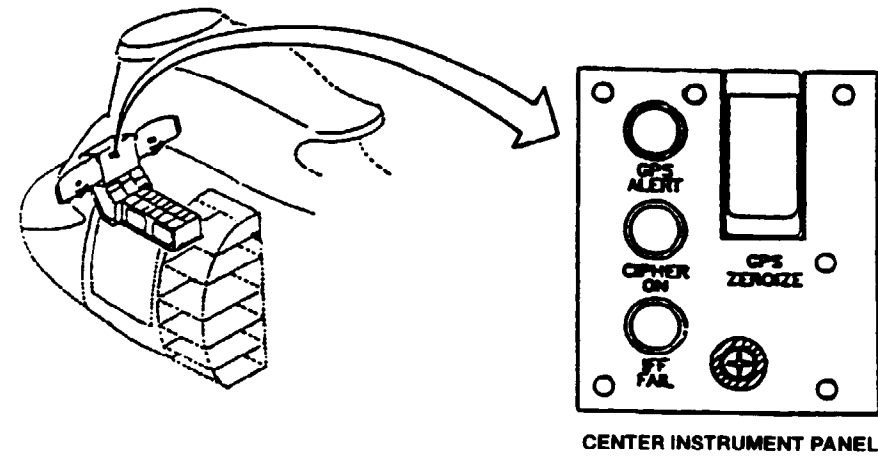

GO TO NEXT PAGE

18-3.7 GPS ALERT INDICATOR DOES NOT ILLUMINATE (Continued)

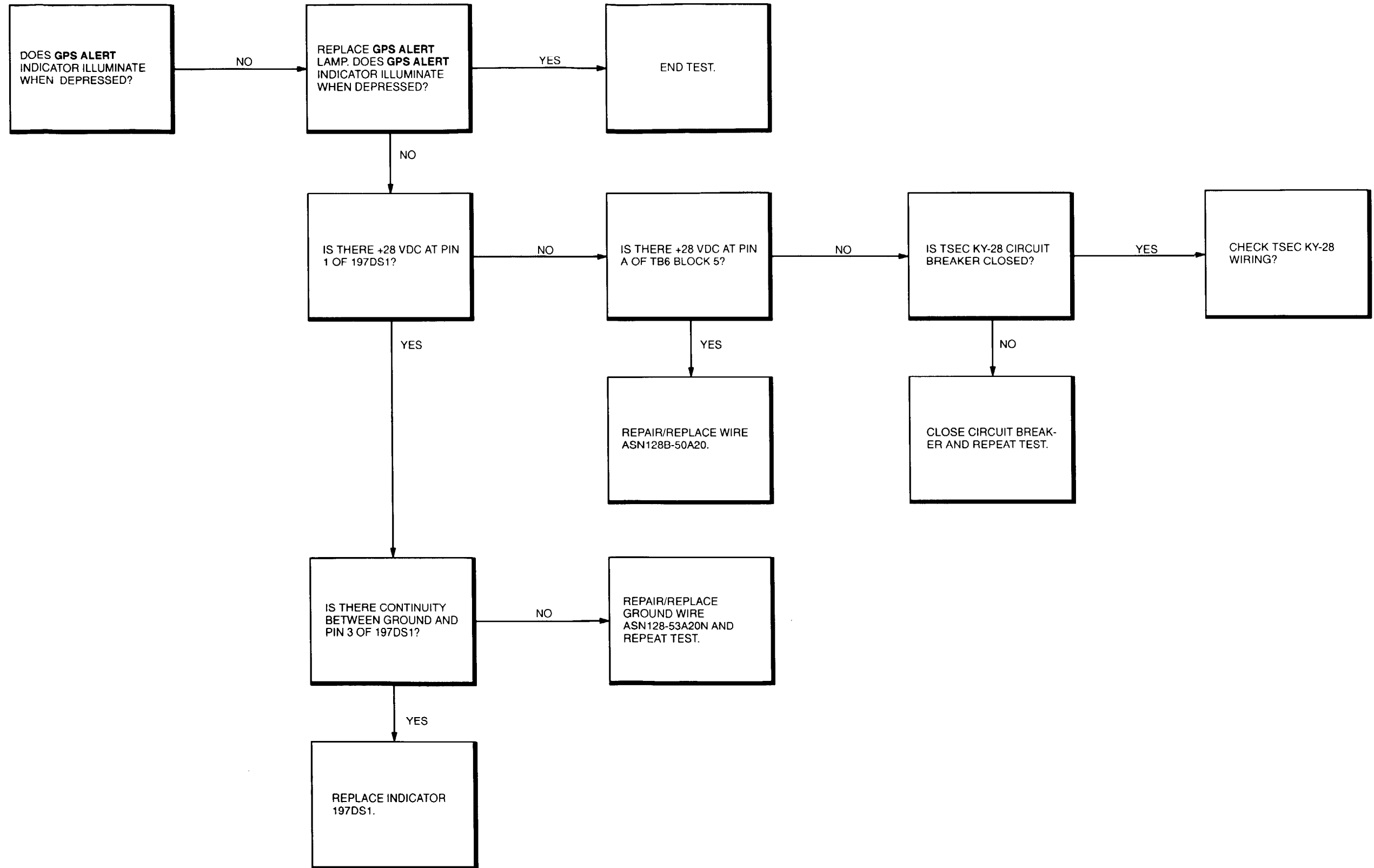

END OF TASK

18-3.8 PRESENT POSITION NOT DISPLAYED ON CDU (Continued)

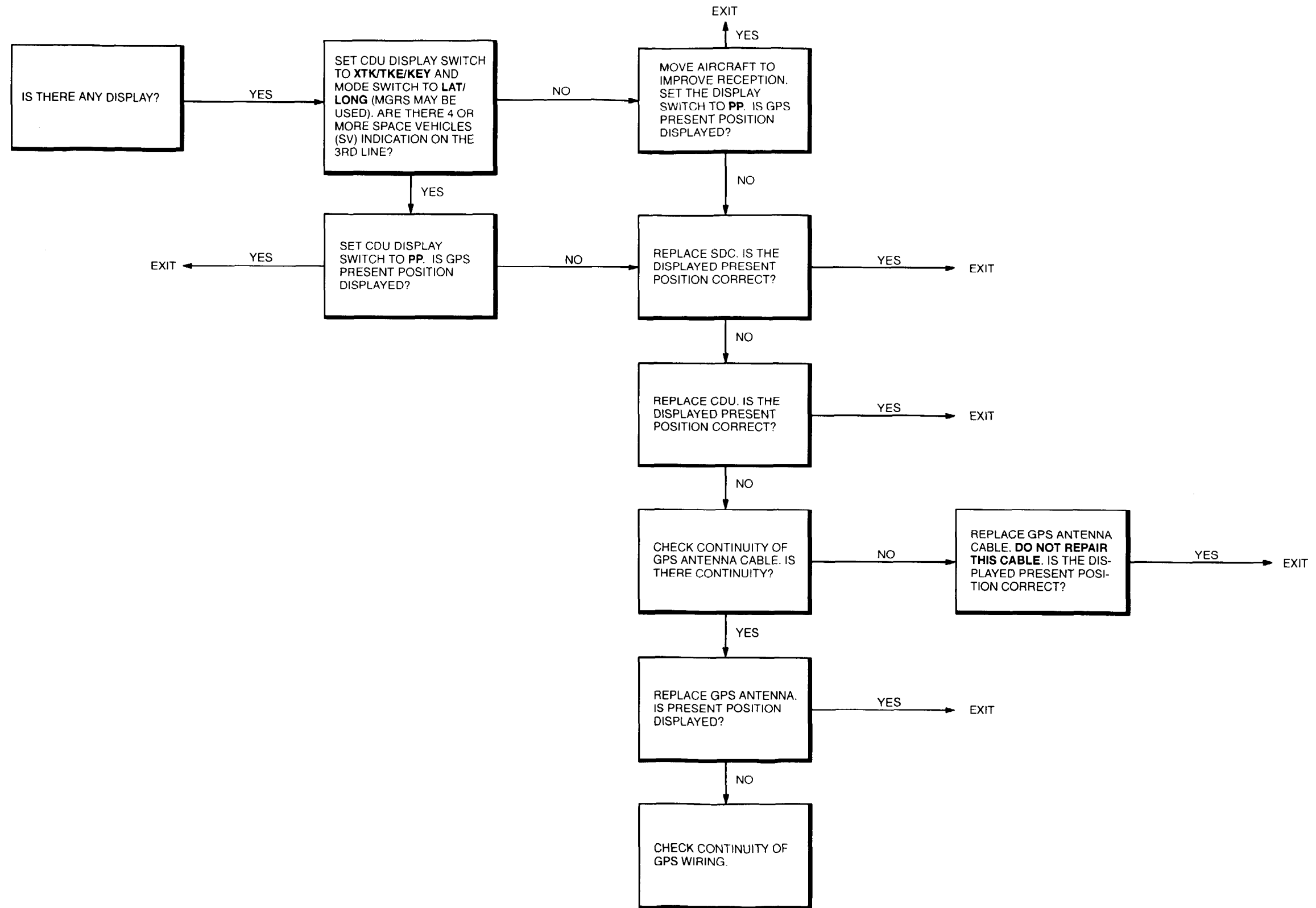

END OF TASK

18-3.9 CDU DOES NOT DISPLAY DOWNLOAD WAYPTS IN PROCESS DURING WAYPOINT LOADING (Continued)

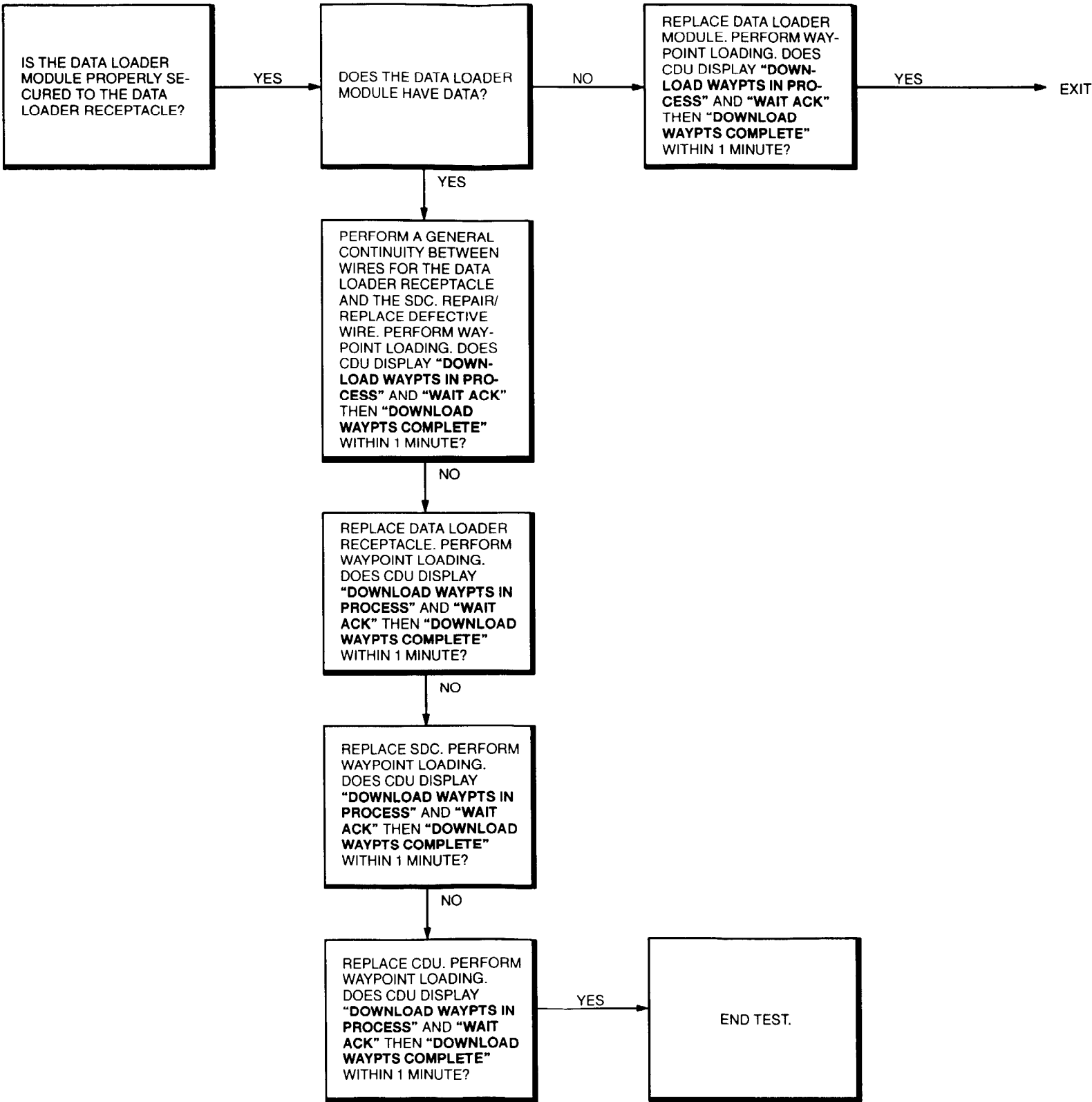

END OF TASK

18-3.10 INDICATIONS ON THE FOUR-LINE DISPLAY AND HSI ARE NOT THE SAME

FAULT ISOLATION PROCEDURES

INITIAL SETUP

Applicable Configurations:
All

References:
TM 11-1520-240-23
TM 11-5841-305-12
TM 55-1520-240-23

Tools:
Electrical Repairer's Tool Kit,
NSN 5180-00-323-4915

Equipment Condition:
TM 55-1520-240-23:
Battery Connected
Electrical Power On
Hydraulic Power Off

Materials:
None

Personnel Required:
Aircraft Electrician

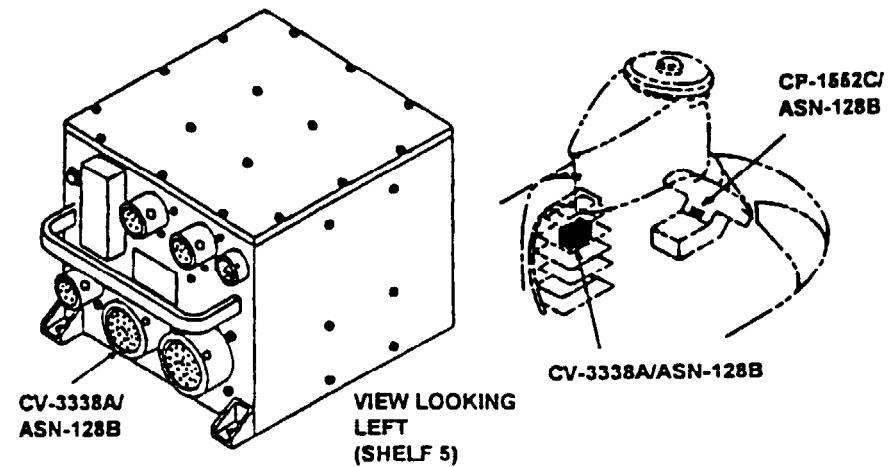
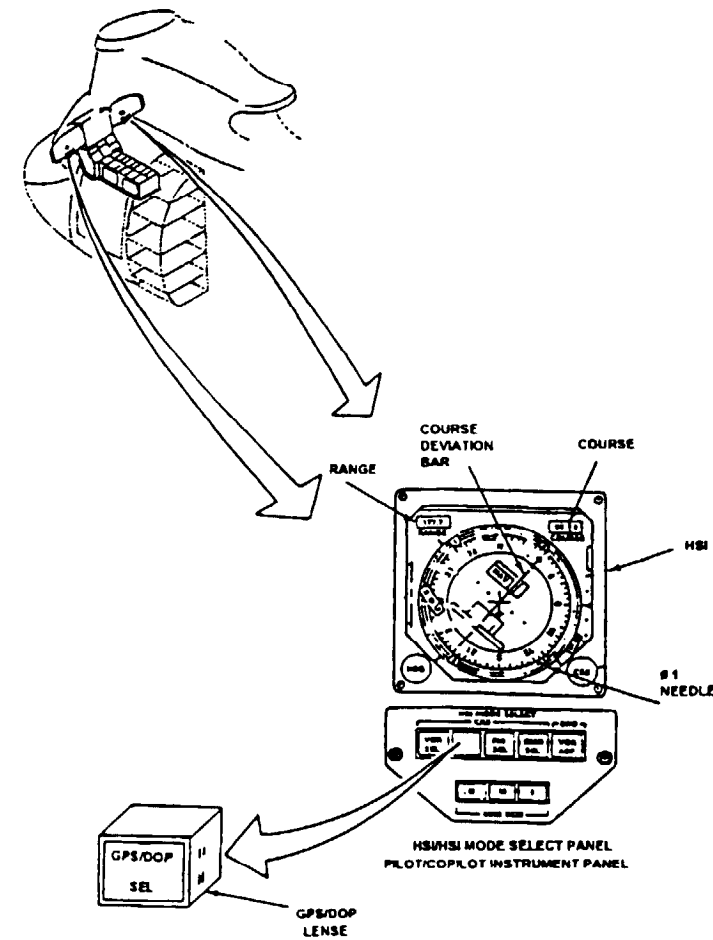
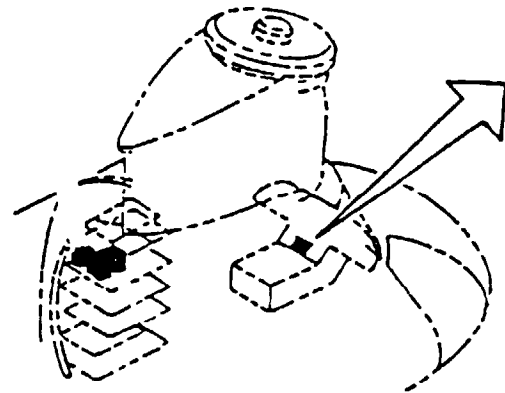
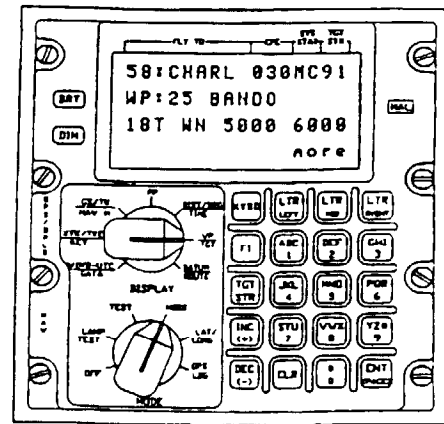

18-3.10 INDICATIONS ON THE FOUR-LINE DISPLAY AND HSI ARE NOT THE SAME (Continued)

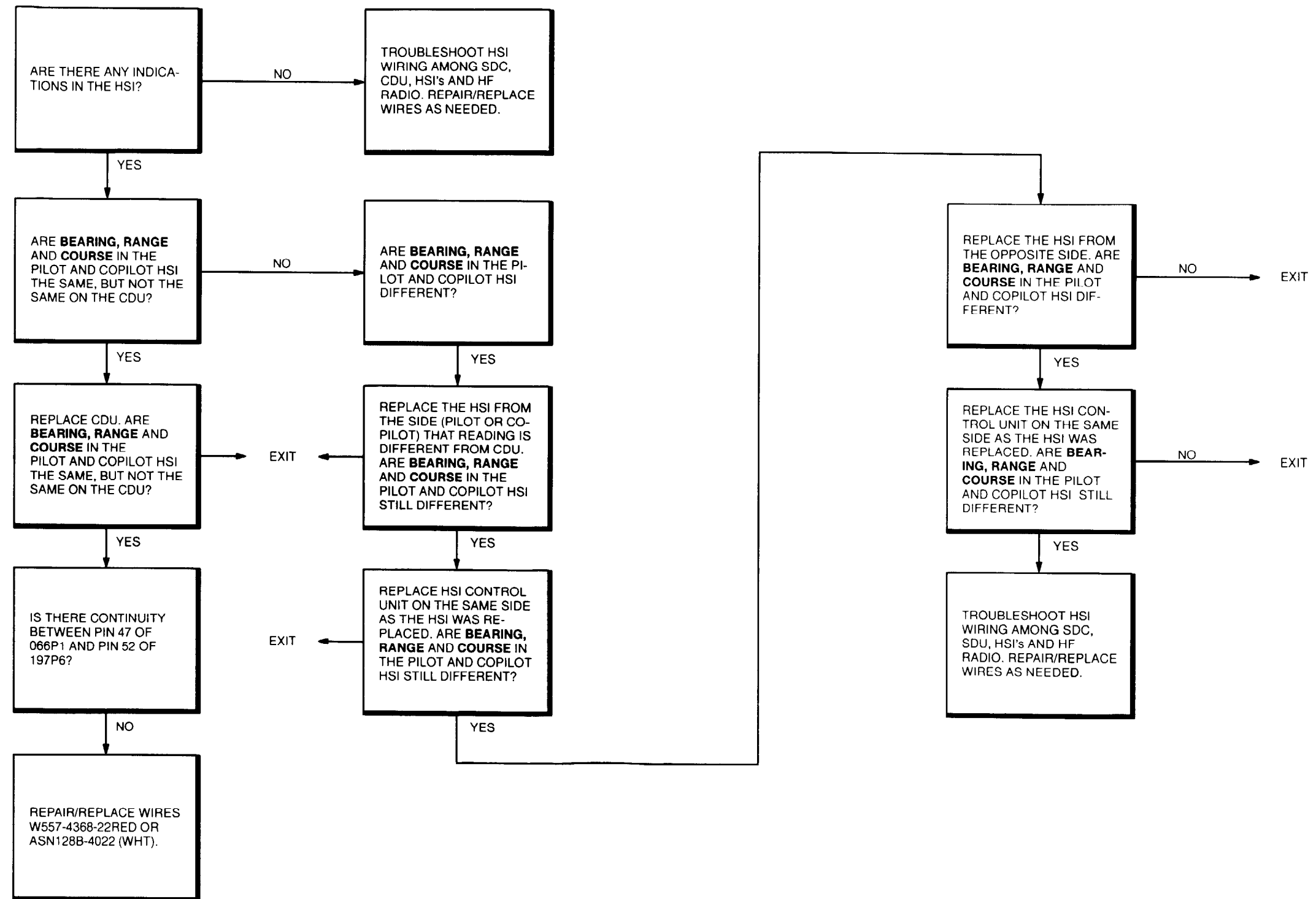

END OF TASK

FAULT ISOLATION PROCEDURES

INITIAL SETUP

Applicable Configurations:

All

References:

TM 11-1520-240-23

TM 11-5841-305-12

TM 55-1520-240-23

Tools:

Electrical Repairer's Tool Kit,
NSN 5180-00-323-4915

Equipment Condition:

TM 55-1520-240-23:

Battery Connected

Electrical Power On

Hydraulic Power Off

Materials:

None

Personnel Required:

Aircraft Electrician

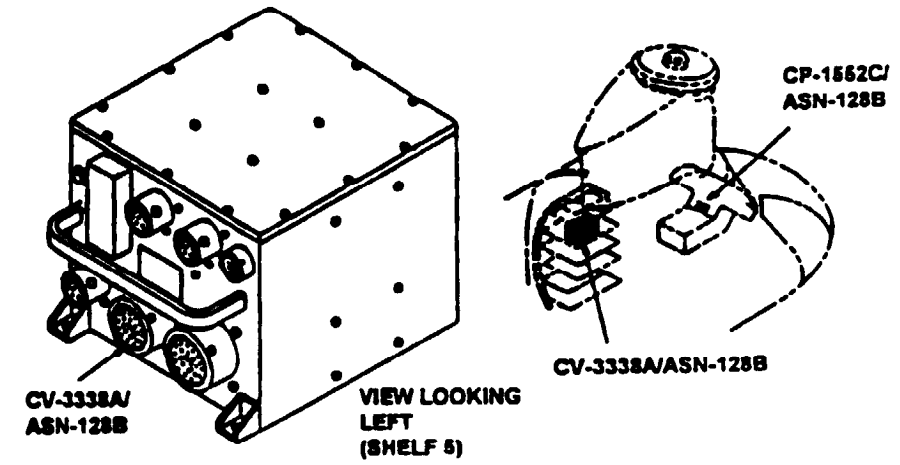
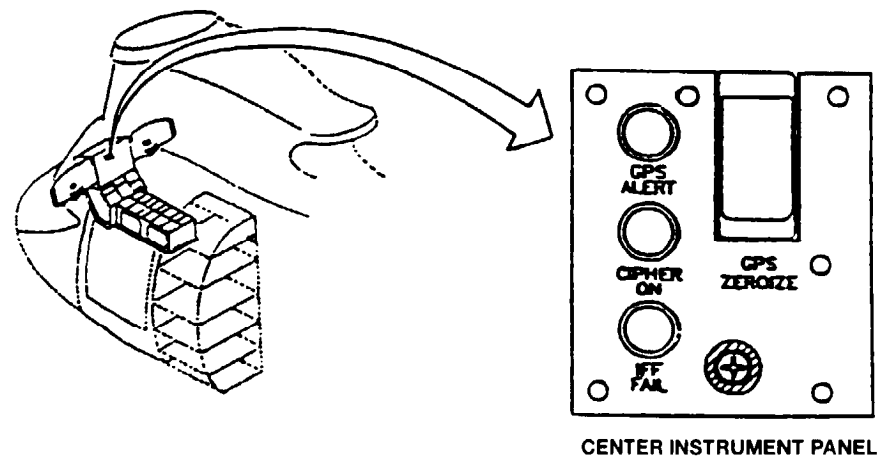

18-3.11 GPS DOES NOT ZEROIZE (Continued)

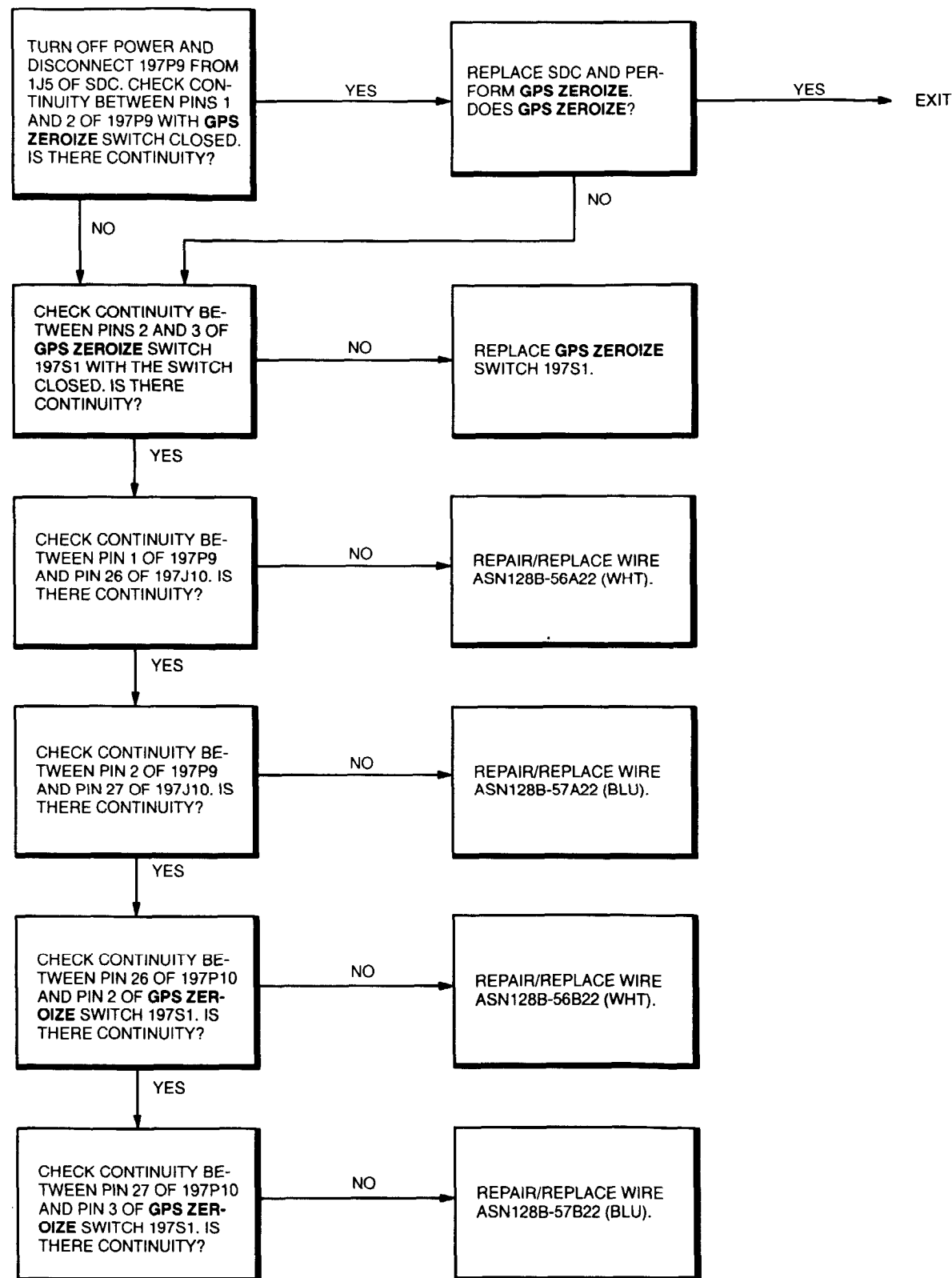

END OF TASK

FAULT ISOLATION PROCEDURES

INITIAL SETUP

Applicable Configurations:

All

References:

TM 11-1520-240-23

TM 11-5841-305-12

TM 55-1520-240-23

Tools:

Electrical Repairer's Tool Kit,
NSN 5180-00-323-4915

Equipment Condition:

TM 55-1520-240-23:

Battery Connected

Electrical Power On

Hydraulic Power Off

Materials:

None

Personnel Required:

Aircraft Electrician

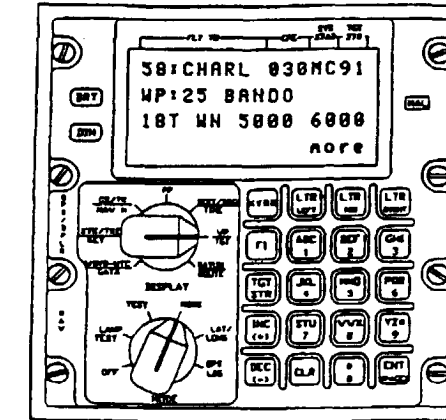

CDU

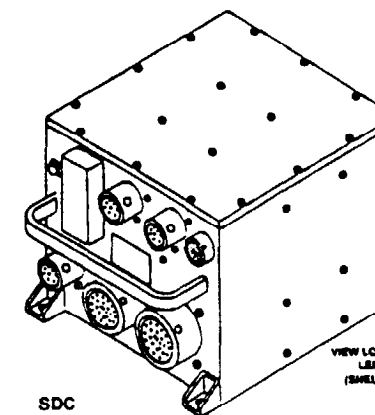
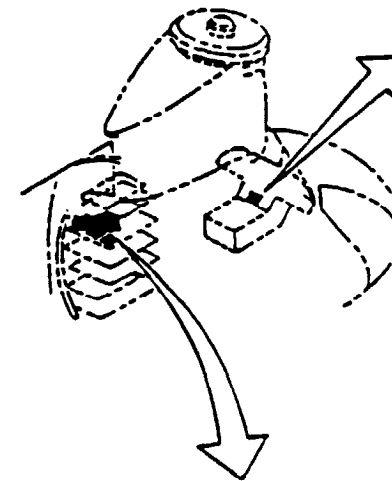

SDC

GO TO NEXT PAGE

18-3.12 GPS HAVEQUICK TIMING NOT WORKING (Continued)

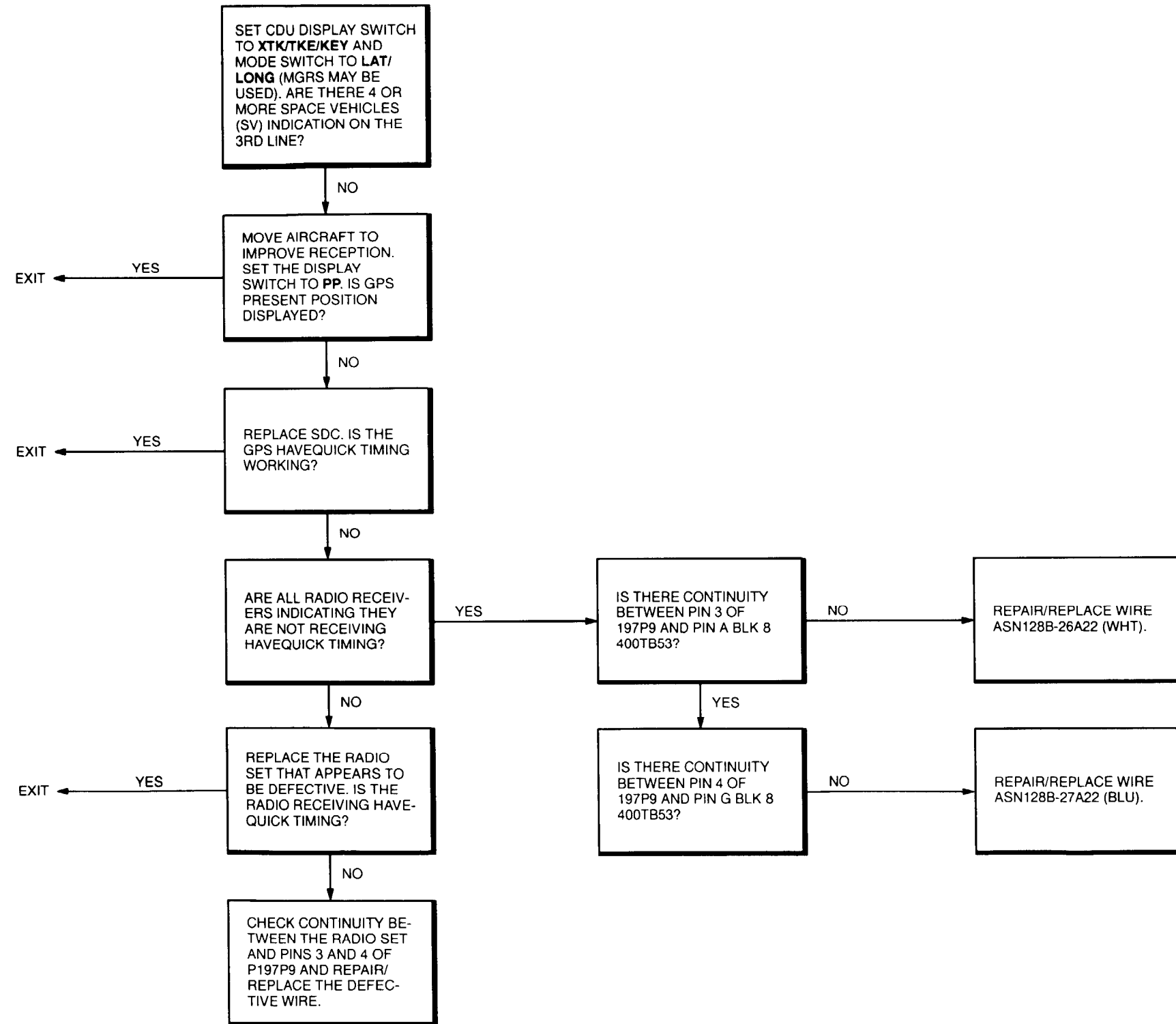

END OF TASK

18-4 HF LIAISON FACILITY

18-4.1 HF LIAISON FACILITY WIRING DIAGRAM (CONTINUED)

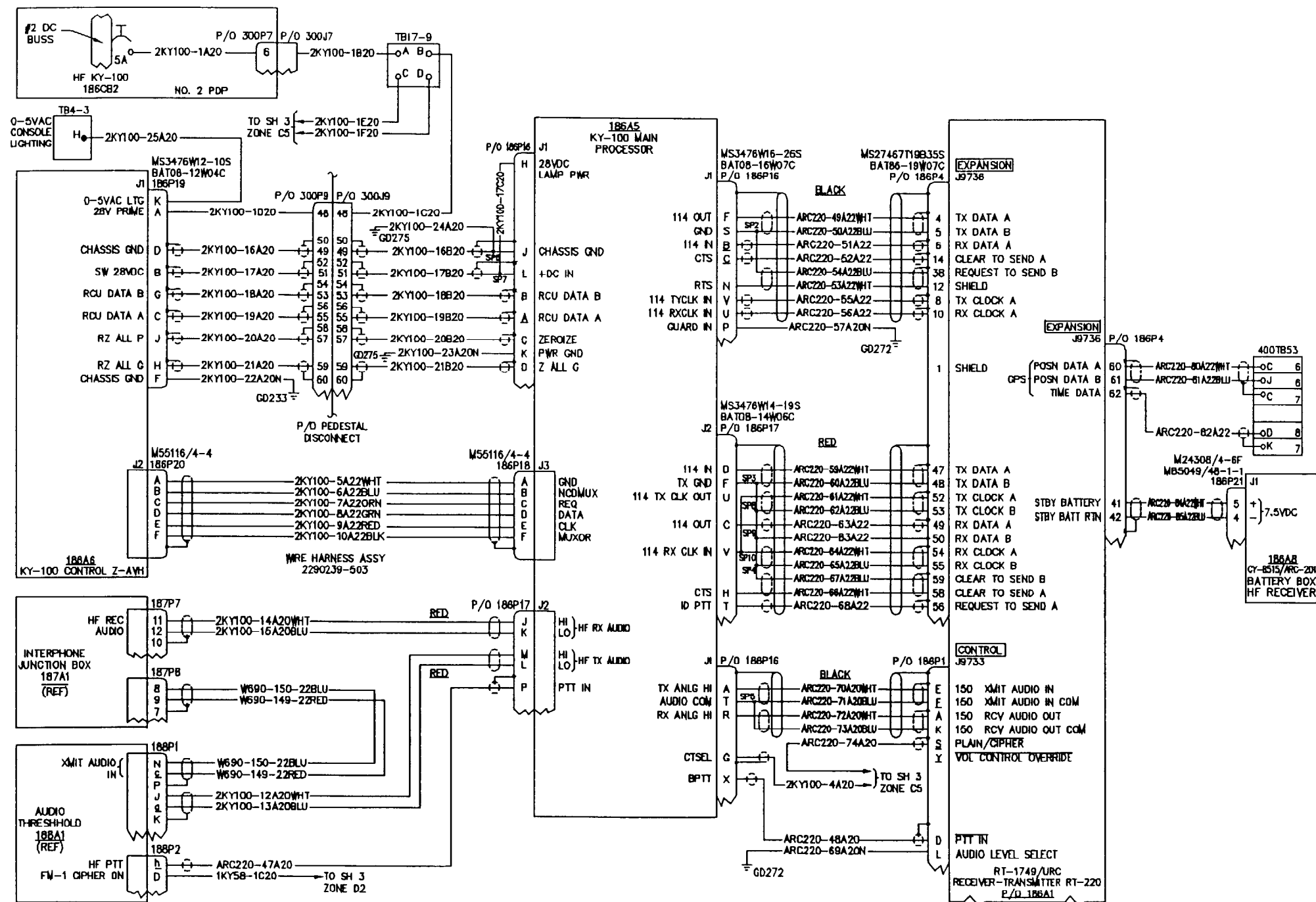

GO TO THE NEXT PAGE

18-4.1 HF LIAISON FACILITY WIRING DIAGRAM (CONTINUED)

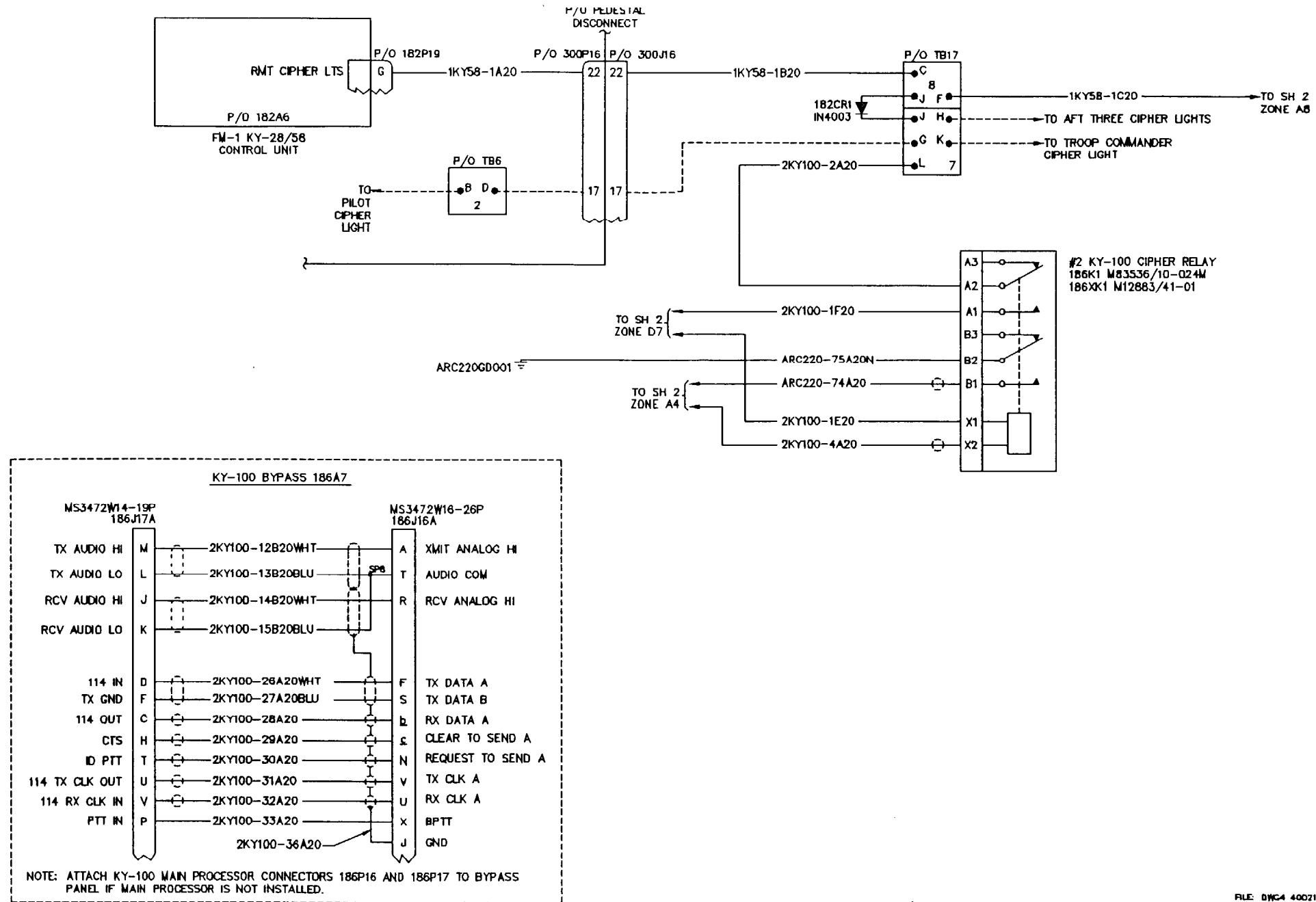

FILE: DMC4 4002173

END OF TASK

18-4.2 HF LIAISON FACILITY VISUAL CHECK

18-4.2

INITIAL SETUP

Applicable Configurations:
All

Tools:
Electrical Repairer's Tool Kit,
NSN 5180-00-323-4915

Materials:
None

Personnel Required:
68F10 Aircraft Electrician

References:
TM 55-1520-240-23

Equipment Condition:
TM 55-1520-240-23:
Battery Disconnected
Electrical Power Off
Avionics Equipment Rack Cover - Cabin Off

TASK	RESULT
1. Check HF Control (1).	Loosen Dzus fasteners and check connector of HF Control (1). If connector is loose or damaged tighten or replace it as required. If wiring to connector is loose or damaged, tighten, repair, or replace it as required. If display screen is damaged in any way replace HF Control (1). If knobs are loose or broken tighten or replace as required. If pushbuttons are damaged replace HF Control (1). Reinstall HF Control (1) in center console tightening the Dzus fasteners.
2. Check KY-100 Control (2).	Loosen Dzus fasteners and check connector of KY-100 Control (2). If connector is loose or damaged tighten or replace it as required. If wiring to connector is loose or damaged, tighten, repair, or replace it as required. If display screen is damaged in any way replace KY-100 Control (2). If knobs are loose or broken tighten or replace as required. If pushbuttons are damaged replace KY-100 Control (2). Reinstall KY-100 Control (2) in center console tightening the Dzus fasteners.
3. Check HF and KY-100 HF COMM Circuit Breakers (3).	If breaker(s) (3) are loose or damaged tighten or replace as required. If wiring to breaker(s) are loose or broken tighten, repair, or replace as required.

TASK	RESULT
4. Check HF Receiver-Transmitter RT-1749(URC) (4).	If receiver (4) is loose or damaged tighten or replace as required. If connectors to the receiver are loose or damaged tighten or replace as required. If wiring or cables to receiver are loose or damaged tighten, repair, or replace as required.
5. Check TSEC/KY-100 Processor (5).	Loosen Dzus fasteners and check connector of KY-100 Processor (5). If connector is loose or damaged tighten or replace it as required. If wiring to connector is loose or damaged, tighten, repair, or replace it as required. If display screen is damaged in any way replace KY-100 Processor (5). If knobs are loose or broken tighten or replace as required. If pushbuttons are damaged replace KY-100 Processor (5). Reinstall KY-100 Processor (5) in bracket under shelf number 2 tightening the Dzus fasteners.
6. Check HF Receiver/Transmitter Battery Box, CY-8515/ARC-201 (6).	If Battery Box (6) is loose or damaged tighten or replace as required. If connector (7) is loose or damaged tighten or replace as required. If wiring to the connector is loose or damaged tighten, repair, or replace as required.
7. Check Power Amplifier-Coupler AM-7531/URC (9).	If Amplifier-Coupler (9) is loose or damaged tighten or replace as required. If connectors to the amplifier are loose or damaged tighten or replace as required. If cables to Amplifier-Coupler J9724, J9721 and J9726 are loose or damaged tighten, repair, or replace as required. If cable to J9725 is loose tighten, if damaged replace ONLY, DO NOT REPAIR THIS CABLE GOING TO ANTENNA.

FOLLOW-ON MAINTENANCE:

Replace Avionics Equipment Rack Cover - Cabin.

GO TO THE NEXT PAGE

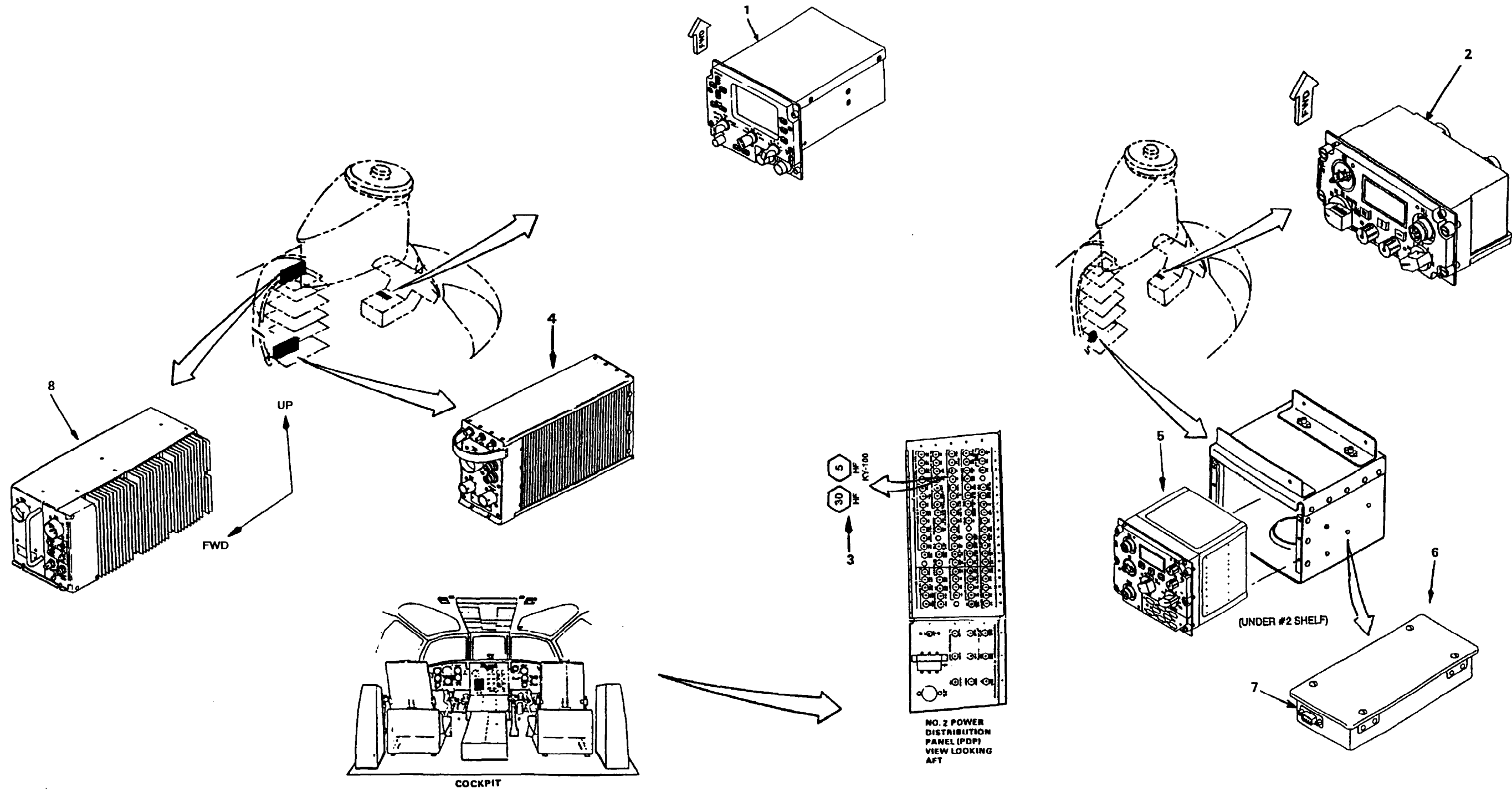

END OF TASK

18-4.3 HF LIAISON FACILITY OPERATIONAL CHECK

8-4.3

INITIAL SETUP

Applicable Configurations:
All

Tools:
Electrical Repairer's Tool Kit,
NSN 5180-00-323-4915

Materials:
None

Personnel Required:
Aircraft Electrician (2)

References:
TM 11-1520-240-23
TM 11-5821-357-12
TM 55-1520-240-10
TM 55-1520-240-23

Equipment Condition:
TM 55-1520-240-23:
Battery Connected
Electrical Power Off
Hydraulic Power Off
HF Liaison Facility Visual Check Performed
(Task 18-4.2)

TASK	RESULT
CHECK CIRCUIT BREAKERS	
1. Check that the following circuit breakers on No. 2 pdp (1) are closed: HF (COMM) HF KY-100 (COMM)	If any circuit breaker is open, close it.
2. Start APU. Refer to task 15-1.5.	APU ON capsule shall come on.
CHECK HF CONTROL C-12436/UR	
3. Turn aircraft CTR CSL LTG control (2) clockwise and counterclockwise while checking HF Control (4) panel lighting.	HF Control (4) panel light shall vary with the changing setting of the aircraft dimmer control (3). If HF Control (4) panel light is not visible or intensity level does not vary with aircraft dimmer control (3), go to task 18-4.4.
4. Turn HF Control (4) Function Switch (7) to T/R and press the HF Control (4) upper and lower brightness switches (6) while checking the HF Control (4) Display (8) Intensity level.	HF Control display screen (8) intensity level shall vary with the changing setting of the brightness switches (6). If no display appears or intensity level does not vary, go to task 18-4.5.
CHECK TSEC/KY-100 CONTROL (RCU)	
5. Turn KY-100 Control (5) BRT PNL Knob (21) clockwise half-way to full-bright. Turn aircraft CTR CSL LTG control (2) clockwise and counterclockwise while checking KY-100 Control (5) panel lighting. Turn CTR CSL LTG Control (2) so KY-100 Control (5) panel lighting is at a comfortable level. Rotate KY-100 Control (5) BRT PNL Knob (21) clockwise and counterclockwise while checking KY -100 Control (5) Display Screen (10) intensity level.	KY-100 Control (5) panel light shall vary with the changing setting of the aircraft dimmer control (2). If KY-100 Control (5) panel light is not visible or intensity level does not vary with KY-100 Control (5) BRT PNL Knob (21), and or if intensity level does not vary with aircraft dimmer control (3) go to task 18-4.6.

TASK	RESULT
6. Turn KY-100 Control (5) Mode Switch (9) to OFFLINE and press the HF Control (4) upper brightness switch (6) and turn the KY-100 Control (5) BRT DISPL knob (24) clockwise and counterclockwise while checking the display screen (10) intensity level.	KY-100 Control display screen (10) intensity level shall vary with the changing setting of the brightness control knob (8). If no display appears or intensity level does not vary, go to task 18-4.6.
<i>CHECK HF RECEIVER-TRANSMITTER RT-1749/URC</i>	
7. Turn HF Control (4) Mode Switch (7) to STBY.	After a 30-second warm-up the HF Control Display (5) shall display SYSTEM TESTING while power-up BIT (P-BIT) is in process. After the test is complete SYSTEM-GO is displayed if all checked good. If a fault is detected, SYSTEM-NO GO is displayed. Go to task 18-4.7 if SYSTEM-NO GO is displayed.
8. While still in STBY mode, depress the line-select switch (3) which points to TEST then depress BIT line-select switch (3) to initiate RCV BIT.	Wait 90 seconds. Upon successful completion of RCV BIT, RCV BIT GO is displayed. If any other message is displayed, go to task 18-4.8.
9. Upon successful completion of RCV BIT and after KEY HF FOR TRANSMIT TEST or PTT FOR XMT BIT is displayed on HF Control (4) Display (8) depress and hold headset PTT switch to Initiate XMT BIT. Release PTT switch.	Wait 90 seconds. Upon successful completion of XMT BIT, XMT BIT GO is displayed. If any other message is displayed, go to task 18-4.8.
10. While still in STBY mode, press FILL line-select switch (3). Use HF Control (4) VALUE switches (12) to select DATA In TYPE: field on line 1 of HF Control Display (8).	The HF Receiver-Transmitter is now ready to receive data from a Data Transfer Device (DTD). Connect DTD to HF Control (4) DATA connector (13) and initiate datafill from DTD. LOADING is displayed during datafill. LOAD COMPLETE is displayed if datafill is successful. If LOAD FAIL is displayed, go to task 18-4.9.
11. While still in STBY mode, press FILL line-select switch (3). Use HF Control (4) VALUE switches (12) to select KEY In TYPE: field on line 1 of HF Control Display (8).	The HF Receiver-Transmitter is now ready to receive secure keys from a Data Transfer Device (DTD). Connect DTD to HF Control (4) KEY connector (20) and initiate keyfill from DTD. LOADING is displayed during fill. LOAD COMPLETE is displayed if keyfill is successful. If LOAD FAIL is displayed, go to task 18-4.9.

GO TO THE NEXT PAGE

TASK	RESULT
12. Turn HF Control (4) Function Switch (7) to T/R, Mode Switch (11) to MAN, Channel/Net Selector (14) to 1, and press the Edit line-select switch (3). Using the cursor keys (23), move cursor to beginning of RCV field and use the Value switches (12) to enter frequency of 2.5 MHz, AM mode. Press RTN line-select switch (3).	This tests reception of a distant station which broadcasts time and frequency primary standards. If reception is not clear, go to task 18-4.10.
13. While still tuned to 2.5MHz, AM, set SQUELCH to minimum by depressing SQL pushbuttons (16). Adjust VOL control (15) to a comfortable listening level. Note pitch of audio tone received. Then change to USB then to LSB mode. Also, vary squelch setting by depressing SQL pushbuttons (16) to verify audio can be muted and unmuted.	If the pitch of the audio tone received changes significantly, go to next task. If squelch does not vary while depressing SQL pushbuttons (16) or audio cannot be muted or unmuted, replace HF Control C-12436/URC.
14. Repeat steps 12 and 13 for the following frequencies: 3.334, 5.0, 7.335, 10.0, 15.0 and 20.0 MHz.	Results should be the same as steps 12 and 13.
15. Using either a preset or manually entered authorized test frequency establish communications with a known properly functioning ground station (NOTE: If ground station is on the same field, set the output power to LOW so communications will not be distorted).	Ensure selected channel is heard loud and clear without undesirable chirps, squeals, or hums, thru both aircraft and ground station radios. If not refer to task 18-4.10.
NOTE	
Ensure Keys and Data are loaded into ARC-220 (steps 10 and 11) before performing step 16.	
16. Set HF Control (4) Function Switch (7) to T/R, and Mode Switch (11) to ALE. Establish communication with a known properly functioning ground station with a compatible ALE fill. Set Channel/Net selector (14) of aircraft radio to call address of ground station. Place a call from aircraft HF radio to ground station. After a link is established and a call made to the ground station, allow the link to be broken by not using the radio for a period of time (normally around 30 seconds, but the exact time is programmed in the fill). Set the Channel/Net selector of ground station to called address of the aircraft radio under test and place a call to aircraft radio.	The radio the call is being generated from should display CALLING on HF Control Display line 3. After an appropriate delay a short gong tone is heard in the headset and LINKED is displayed on display line 3. If CALL FAIL is displayed on display line 3, go to task 18-4.11. Communication can begin after link is established. Headset audio is muted until a link is established. If headset audio is not muted or communications cannot be established or is not clear, go to task 18-4.10. After a period of inactivity the link should be broken. If link does not break, replace HF Receiver-Transmitter RT-1749/URC. The radio receiving an ALE call, will have INCOMING CALL displayed on HF Control display line 3 and the address fields will change to the caller's.

TASK	RESULT
NOTE	
Ensure Keys and Data are loaded into ARC-220 (steps 10 and 11) before performing step 17.	
17. Set HF Control (4) Function Switch (7) to T/R, and Mode Switch (7) to ECCM. Establish communication with a known functional ground station with a compatible ECCM fill. Set Channel/Net selector (14) of aircraft radio to ECCM net of ground station. Place a call from aircraft HF radio to ground station. After a link is established and a call made to the ground station, allow the link to be broken by not using the radio for a period of time (normally around 30 seconds, the exact time is programmed in the fill). Set the Channel/Net selector of ground station to ECCM net of the aircraft radio under test and place a call to aircraft radio.	ALE address. When a link is established, a short gong tone is heard in the headset and LINKED is displayed on display line 3. Communication should then be generated by the calling station. If reception is not clear, go to task 18-4.10.
NOTE	
If the HF Control displays UNTUNED or UNSYNCH after an ECCM net is chosen, either press TUNE line-select switch or microphone PTT switch. HF Control (4) will display TUNING followed by SYNCHING while the process is occurring. When SYNCHING is no longer displayed, the system is ready for ECCM operation. If system cannot be tuned or synched, go to task 18-4.12. The radio from which a call is initiated the following will occur: preamble tones will be heard, wait until they cease before communicating; when link is established a short gong tone sounds in headset, LINKED is displayed and headset audio is restored. If this calling sequence does not occur, go to tasks 18-4.13 and 18-4.14. If after a period of inactivity the link is not broken, go to task 18-15. When a call is being received RCVING PREAMBLE is displayed before communications from the calling station is heard. If RCVING PREAMBLE is not displayed go to task 18-4.16. If communications is not received from calling station, go to task 18-4.10.	
NOTE	
Perform the following step after all checks are complete and just before shutdown.	
18. Gently pull and turn HF Control (4) Function Switch (7) to ZERO position.	All preprogrammed information, including datafill and keyfill data, will be erased. The HF Control (4) will display ZEROIZED. If ZEROIZED is not displayed, go to task 18-4.17.

GO TO THE NEXT PAGE

18-4.3 HF LIAISON FACILITY OPERATIONAL CHECK (CONTINUED)

18-4.3

TASK

RESULT

CHECK TSEC/KY-100 PROCESSOR

19. Turn KY-100 Control (5) MODE switch (9) to OFFLINE and PRESET switch (17) to MAN. Connect a fill device to KY-100 Control (5) fill connector (18). Push up arrow (22) until KEY OPS is displayed on display (10). Push INIT button (19) to display LOAD KEY. Push INIT button (19), LOAD N with a flashing N will be shown on KY-100 Control (5) display (10), where the N indicates currently selected key location, which can be changed by pressing the up or right arrow as needed. Press INIT button (19). The entire LOAD N message will now be flashing. Turn on fill device and select key to be loaded. Press the INIT button (19) on KY-100 control (5). When keyfill is complete, turn off and disconnect the fill device from KY-100 control (5). Rotate KY-100 Control (5) Mode switch out of OFFLINE to exit key load.

NOTE

Perform the following step after all checks are complete and just before shutdown.

20. Pull the KY-100 Control (5) Mode Switch (9) and rotate it to Z ALL position.

Upon completion of a successful load, a pass tone will be heard and the display (10) will momentarily indicate KEY N, where N is the key location loaded. If this does not occur, go to task 18-4.18. The display (10) will then display, LOAD N with N flashing. This step can be repeated to load additional keys.

All keys stored in locations 1 thru 6 and U will be erased. The KY Control (5) will display ZEROED and a tone will be audible in headset. When MODE switch is rotated out of Z ALL position, PUSH INIT will be displayed meaning a COLD START is needed (a keyfill is necessary). If ZEROED is not seen on KY-100 Control (5) display (10), tone is not heard in headset, or PUSH INIT is not displayed when rotated out of Z ALL position, go to task 18-4.19.

SECURE VOICE CHECK - RT-17429/URC AND TSEC/KY-100

NOTE

Ensure both KY-100 and HF Radio have appropriate keys loaded for mode used.

21. Utilizing a known functional ground station with compatible HF and KY-100 keys loaded and an appropriate test frequency, turn aircraft KY-100 Control (5) Mode switch (9) to CT. Go into CT menu and set to CT. Set ground station KY-100 Control Mode switch to PT. Transmit from ground station to aircraft HF system.

The PT annunciator should be lit on the KY-100 Control (5) Display (10) and plaintext should be heard in the headset. If neither occur, go to task 18-4.20.

TASK

RESULT

22. Utilizing a known functional ground station with compatible HF and KY-100 keys loaded and an appropriate test frequency, turn the aircraft KY-100 Control (5) Mode switch (9) to CT. Go into the CT menu and set to CT. Set the ground station KY-100 Control Mode switch to CT. Transmit from the ground station to aircraft HF system.

The RX and V annunciators should be lit on the KY-100 Control (5) Display (10) and plaintext should be heard in the headset. If neither occur, go to task 18-4.21.

23. Utilizing a known functional ground station with compatible HF and KY-100 keys loaded and an appropriate test frequency, turn the aircraft KY-100 Control (5) Mode switch (9) to CT. Go into the CT menu and set to CT. Set the ground station KY-100 Control Mode switch to CT. Transmit from the aircraft HF system to the ground station.

The TX and V annunciators should be lit on the KY-100 Control (5) Display (10) in the aircraft and plaintext communication should be heard at ground station. If neither occur, go to task 18-4.21.

24. Utilizing a known functional ground station with compatible HF and KY-100 keys loaded and an appropriate test frequency, turn the aircraft KY-100 Control (5) Mode switch (9) to CT. Go into the CT menu and set to CT ONLY. Set the ground station KY-100 Control Mode switch to PT. Transmit from the ground station to aircraft HF system.

No communication should be audible in the aircraft headset. If communication does come thru, go to task 18-4.21.

25. Utilizing a known functional ground station with compatible HF and KY-100 keys loaded and an appropriate test frequency, turn the aircraft KY-100 Control (5) Mode switch (9) to PT. with the CT menu set to CT. Set the ground station KY-100 Control Mode switch to CT. Transmit from the ground station to aircraft HF system.

No communication should be audible in the aircraft headset. If communication does come thru, go to task 18-4.21.

SYSTEM SHUTDOWN

26. Rotate HF Control (4) Function Switch (7) and KY-100 Control (5) Mode Switch (9) to OFF. Pull HF (COMM) and HF KY-100 (COMM) circuit breakers on No. 2 pdp.

27. Stop APU. Refer to task 15-1.5.

APU ON capsule shall go out.

FOLLOW-ON MAINTENANCE:

TM 55-1520-240-23:
Electrical Power Off
Battery Disconnected

GO TO THE NEXT PAGE

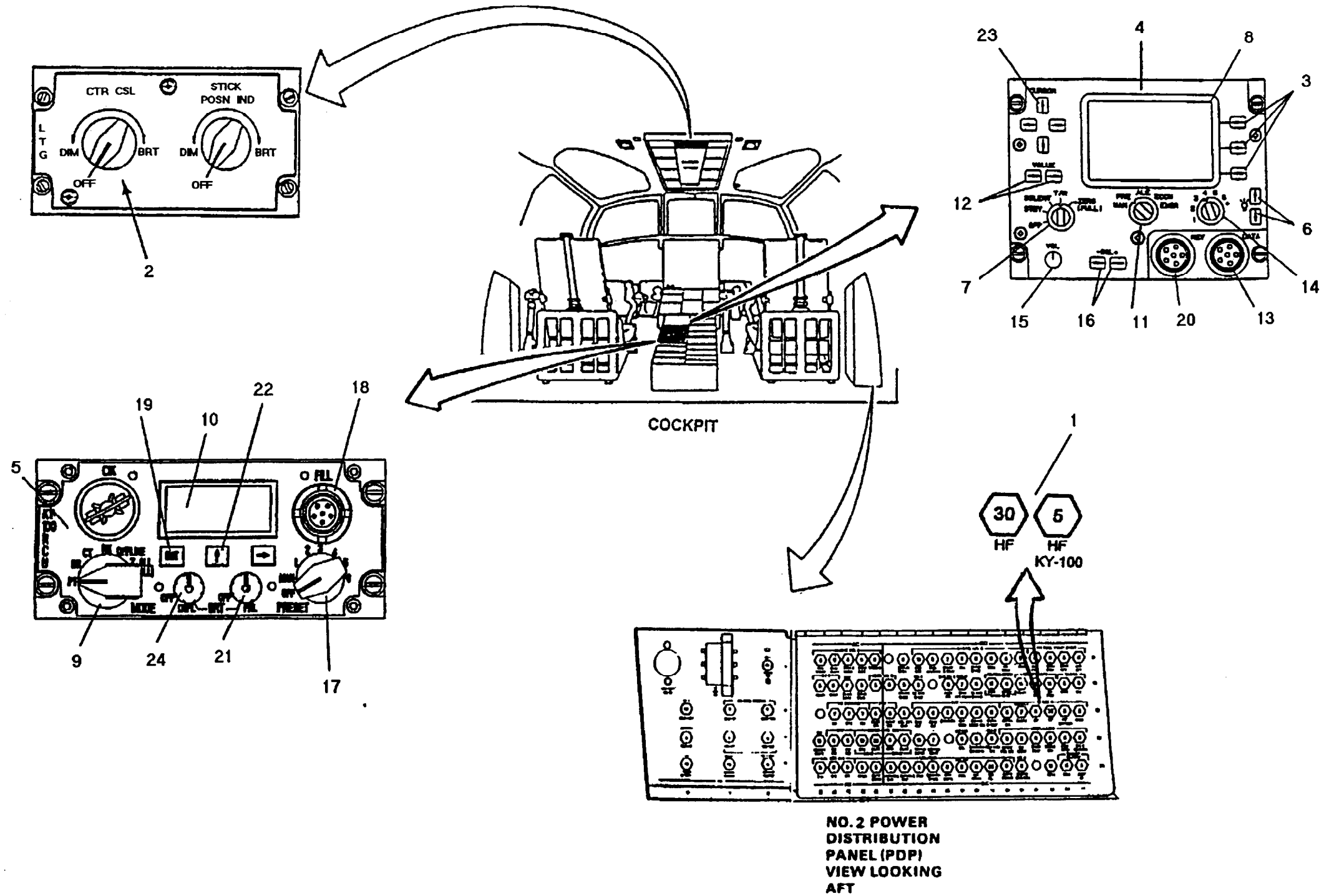

18-4.4 AN/ARC-220 CONTROL - DISPLAY SCREEN INTENSITY LEVEL DOES NOT VARY WITH BRIGHTNESS SWITCHES:

INITIAL SETUP

Applicable Configurations:
All

Tools:
Electrical Repairer's Tool Kit,
NSN 5180-00-323-4915

Materials:
None

Personnel Required:
Aircraft Electrician (2)

References:

- TM 11-1520-240-23
- TM 11-5821-357-12
- TM 55-1520-240-10
- TM 55-1520-240-23

Equipment Condition:

- TM 55-1520-240-23:
- Battery Connected
- Electrical Power Off
- Hydraulic Power Off
- HF Liaison Facility Visual Check Performed (Task 18-4.2)

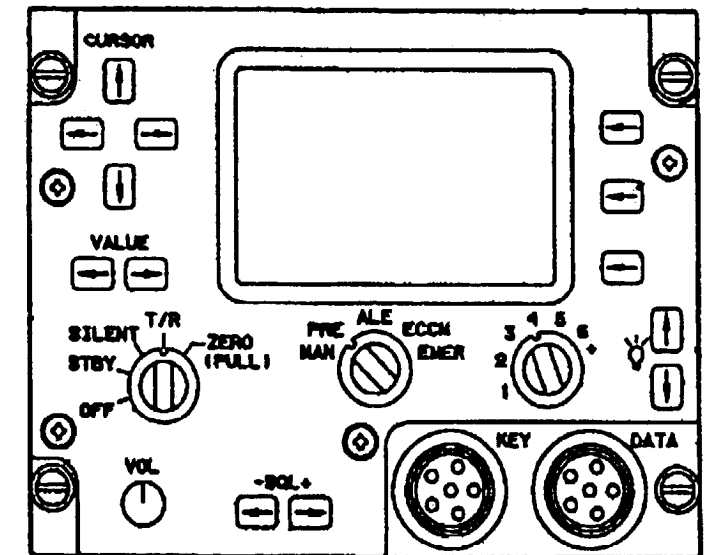
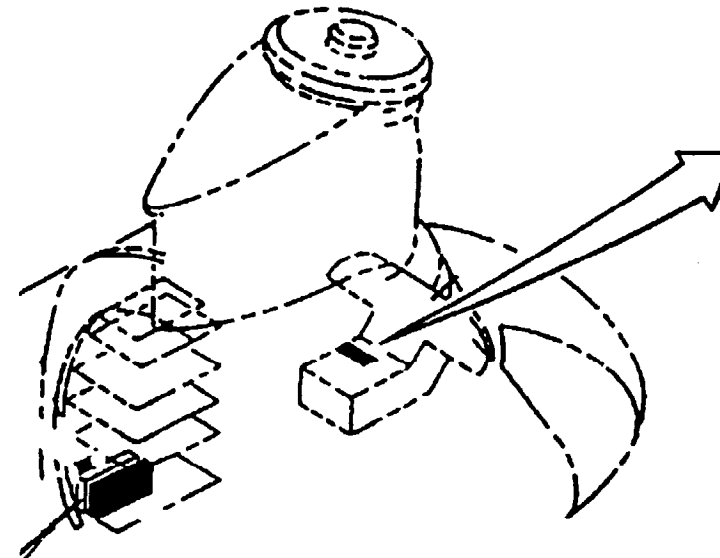
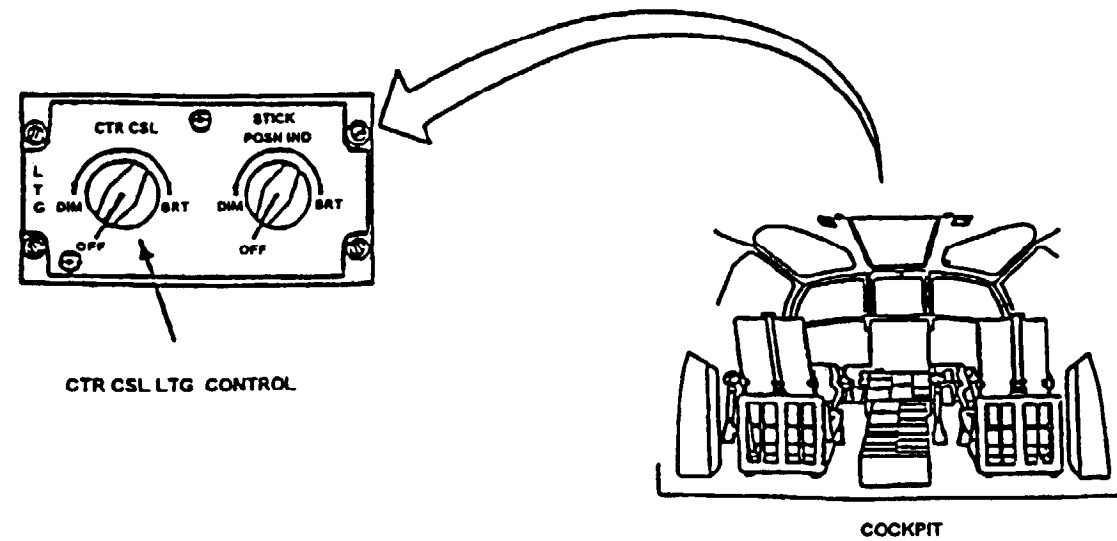

GO TO THE NEXT PAGE

18-4.5 AN/ARC-220 CONTROL - ND DISPLAY VISIBLE

INITIAL SETUP

Applicable Configurations:

All

Tools:

Electrical Repairer's Tool Kit,
NSN 5180-00-323-4915

Materials:

None

Personnel Required:

Aircraft Electrician (2)

References:

- TM 11-1520-240-23
- TM 11-5821-357-12
- TM 55-1520-240-10
- TM 55-1520-240-23

Equipment Condition:

- TM 55-1520-240-23:
- Battery Connected
- Electrical Power Off
- Hydraulic Power Off
- HF Liaison Facility Visual Check Performed (Task 18-4.2)

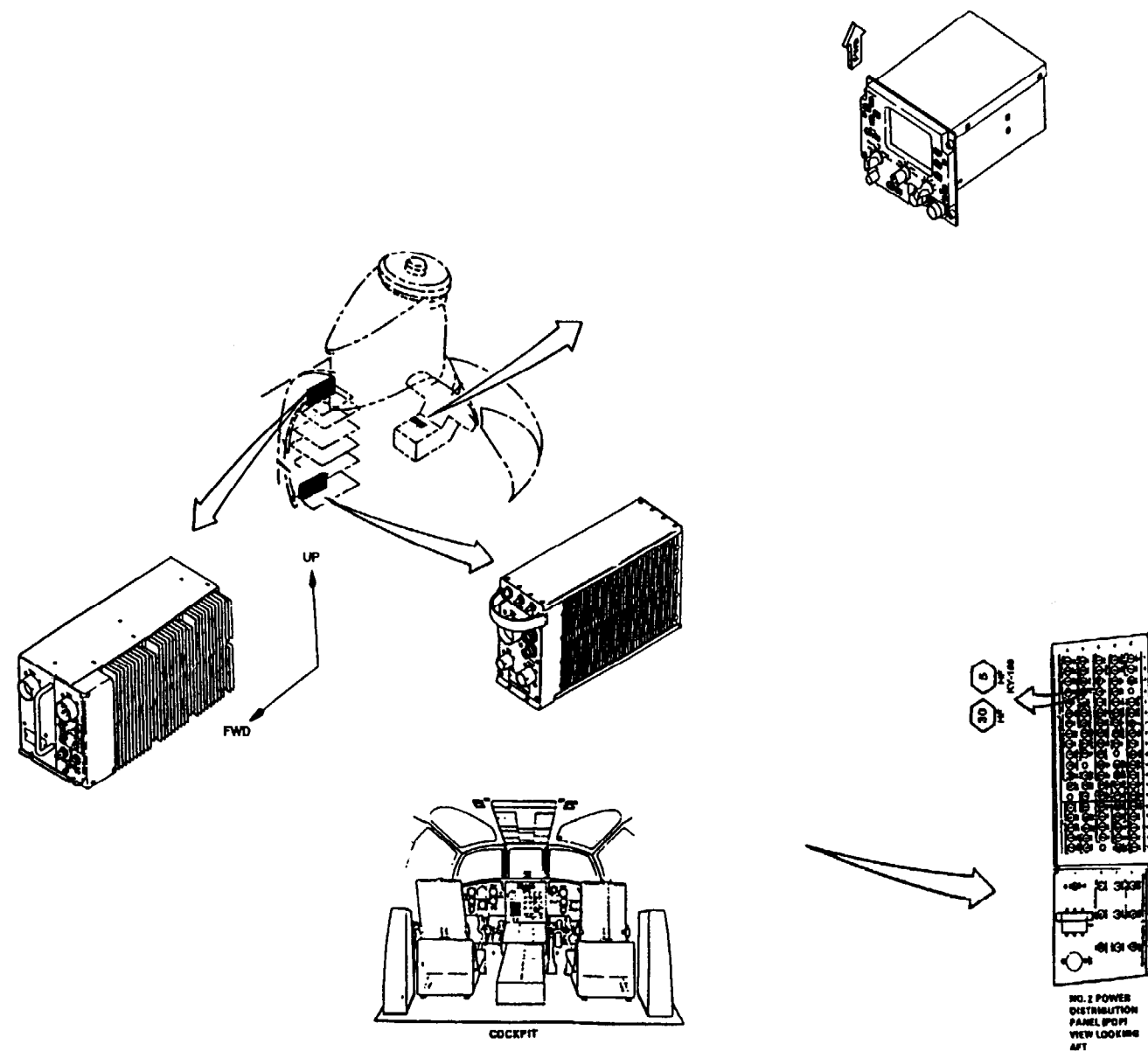

GO TO THE NEXT PAGE

18-4.5 AN/ARC-220 CONTROL - NO DISPLAY VISIBLE (CONTINUED)

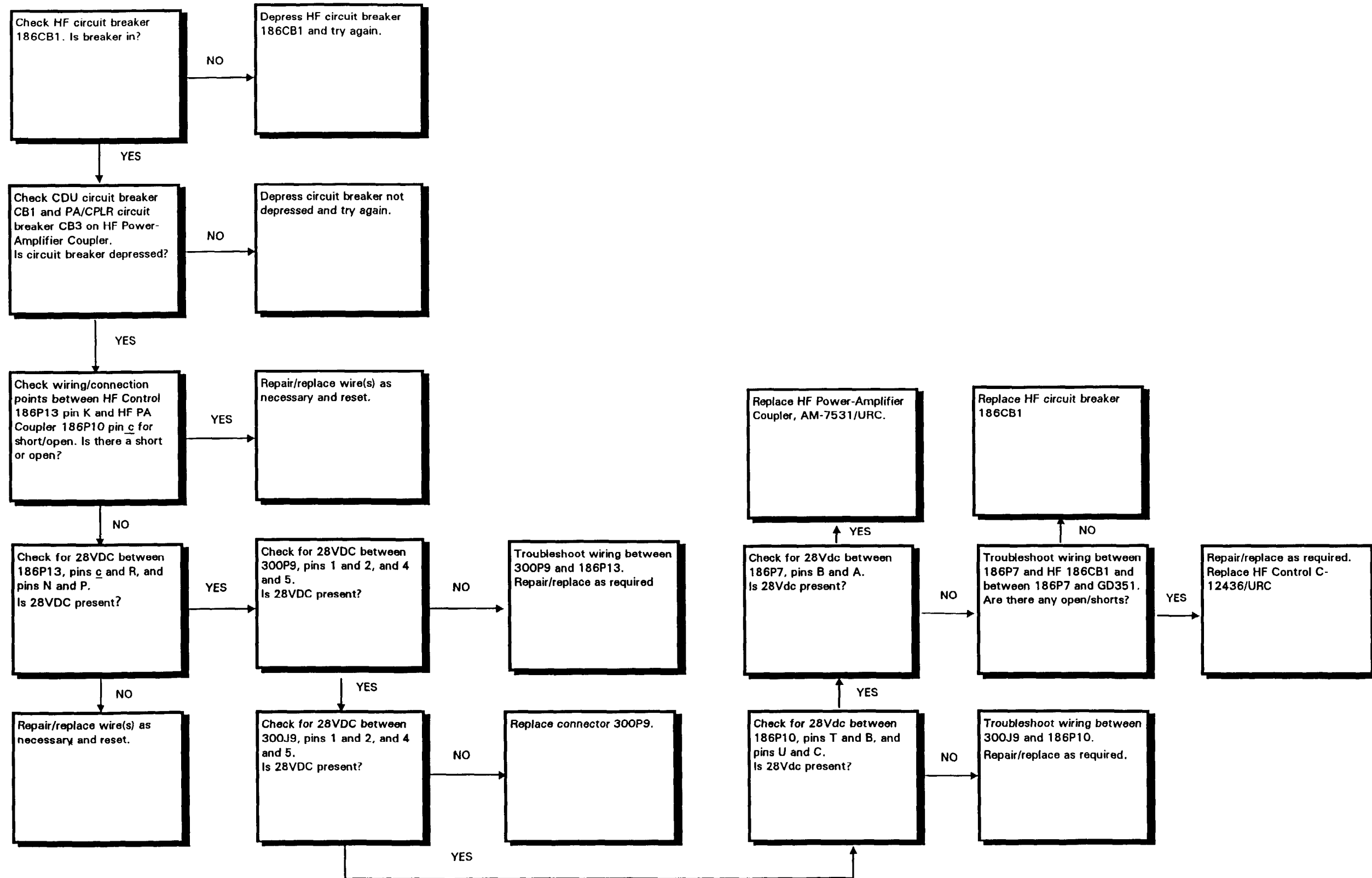

END OF TASK

18-4.6 TSEC/KY-100 CONTROL RCU - NO DISPLAY.

INITIAL SETUP

References:

- TM 11-1520-240-23
- TM 11-5821-357-12
- TM 55-1520-240-10
- TM 55-1520-240-23

Applicable Configurations:

All

Tools:

Electrical Repairer's Tool Kit,
NSN 5180-00-323-4915

Equipment Condition:

- TM 55-1520-240-23:
- Battery Connected
- Electrical Power Off
- Hydraulic Power Off
- HF Liaison Facility Visual Check Performed
(Task 18-4.2)

Materials:

None

Personnel Required:

Aircraft Electrician (2)

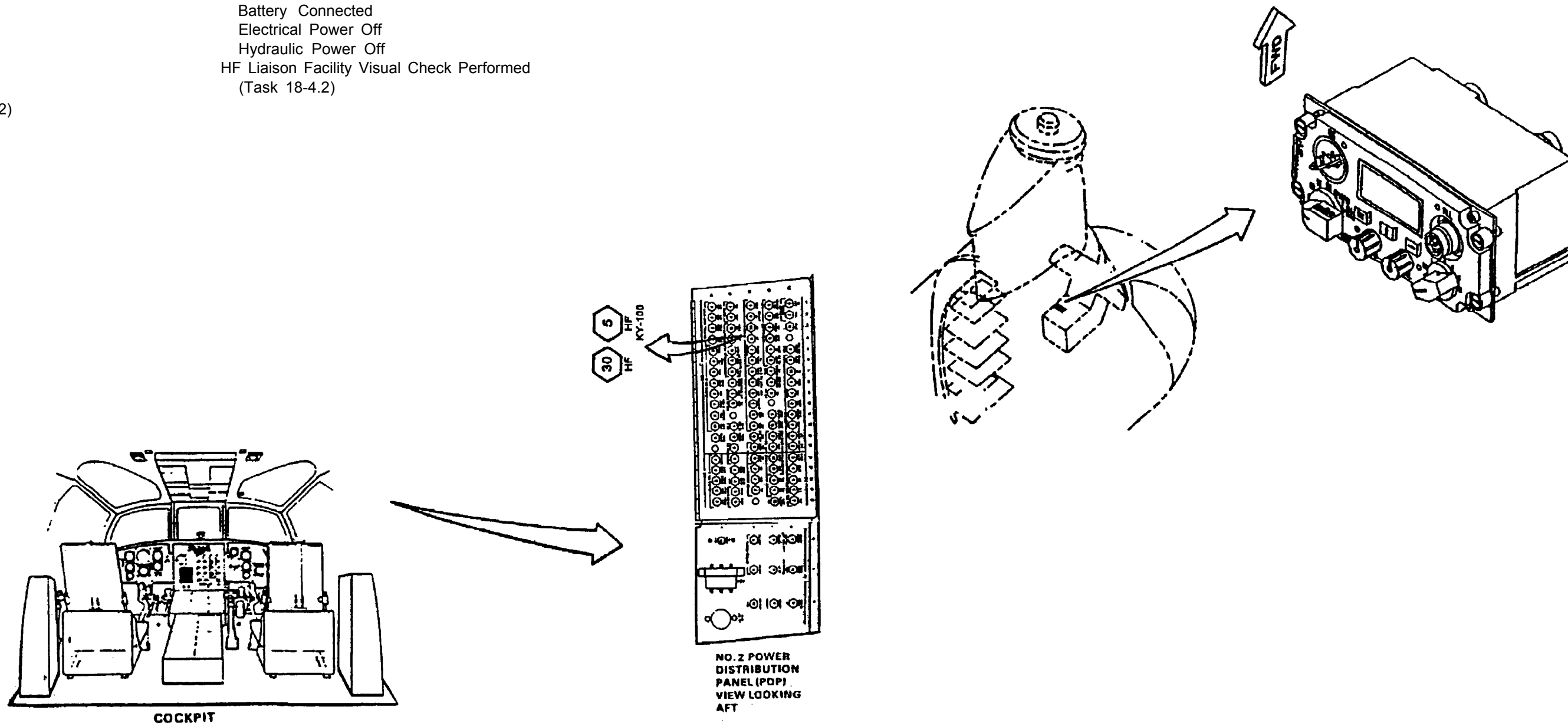

GO TO THE NEXT PAGE

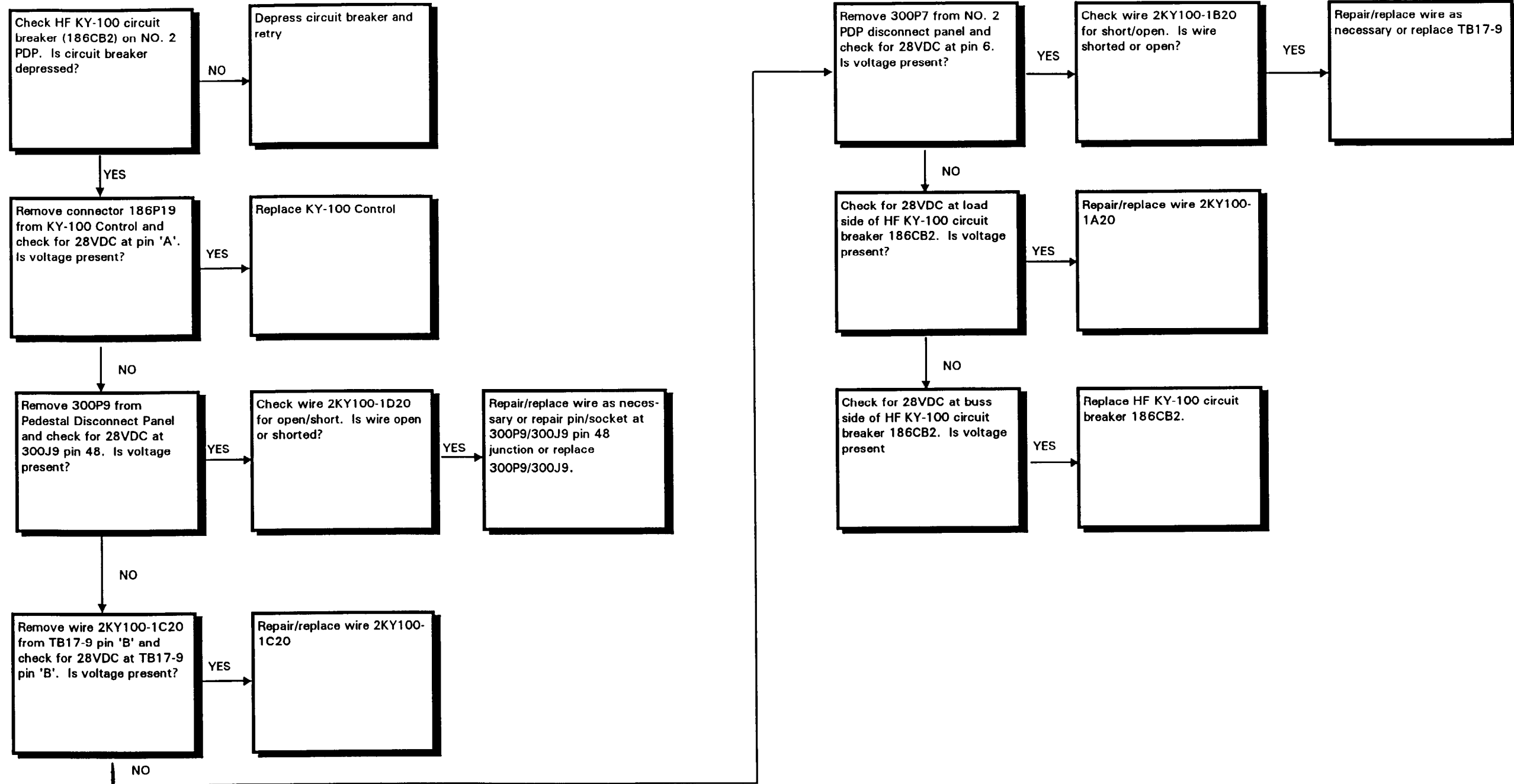

END OF TASK

18-4.7 AN/ARC-220 CONTROL DISPLAYS 'SYSTEM-NOGO' AFTER POWER UP BIT (P-BIT TEST).

INITIAL SETUP

References: 18-4.7

Applicable Configurations:

All

- TM 11-1520-240-23
- TM 11-5821-357-12
- TM 55-1520-240-10
- TM 55-1520-240-23

Tools:

Electrical Repairer's Tool Kit,
NSN 5180-00-323-4915

Equipment Condition:

- TM 55-1520-240-23:
- Battery Connected
- Electrical Power Off
- Hydraulic Power Off
- HF Liaison Facility Visual Check Performed (Task 18-4.2)

Materials:

None

Personnel Required:

Aircraft Electrician (2)

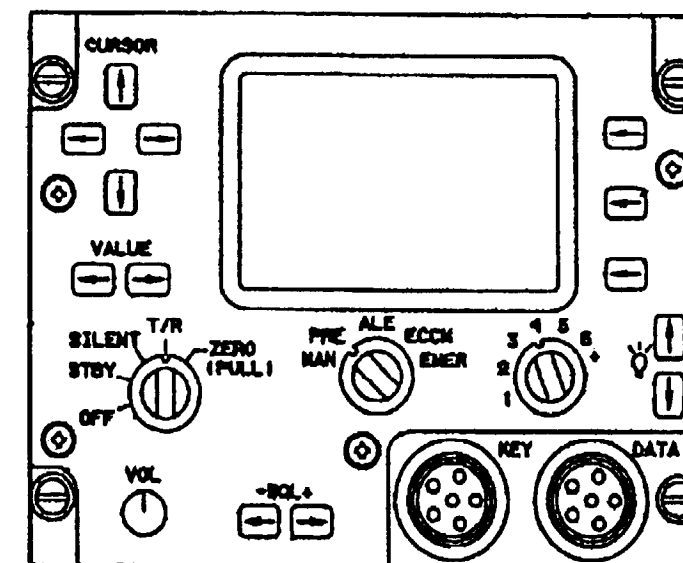
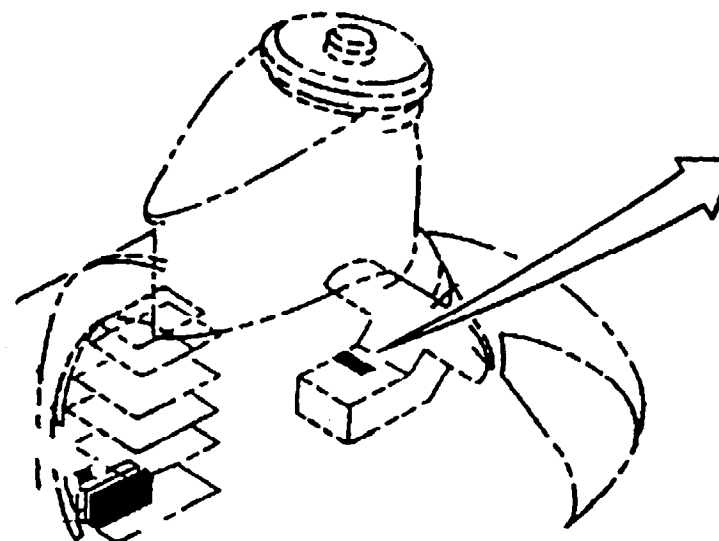

GO TO THE NEXT PAGE

18-4.7 AN/ARC-220 CONTROL DISPLAYS "SYSTEM-NOGO" AFTER POWER UP BIT (P-BIT TEST)
(CONTINUED).

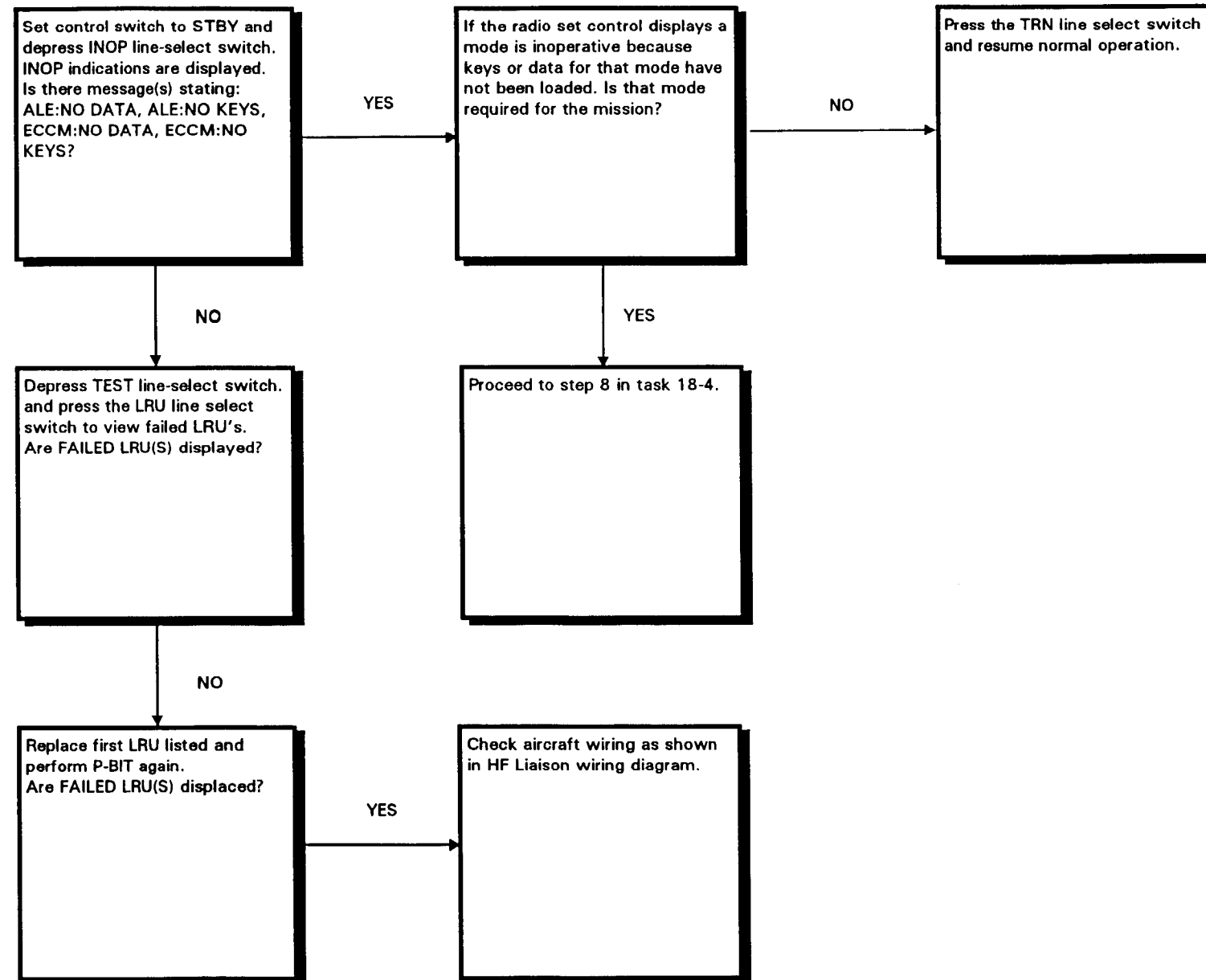

END OF TASK

18-4.8

**18-4.8 AN/ARC-220 CONTROL DISPLAYS "SYSTEM-NOGO RT-CDU COMM FAIL"
DURING RCV OR XMT TEST).**

18-4.8

INITIAL SETUP

References:

- TM 11-1520-240-23
- TM 11-5821-357-12
- TM 55-1520-240-10
- TM 55-1520-240-23

-Applicable Configurations:

All

Tools:

Electrical Repairer's Tool Kit,
NSN 5180-00-323-4915

Materials:

None

Personnel Required:

Aircraft Electrician (2)

Equipment Condition:

- TM 55-1520-240-23:
 - Battery Connected
 - Electrical Power Off
 - Hydraulic Power Off
 - HF Liaison Facility Visual Check Performed
(Task 18-4.2)

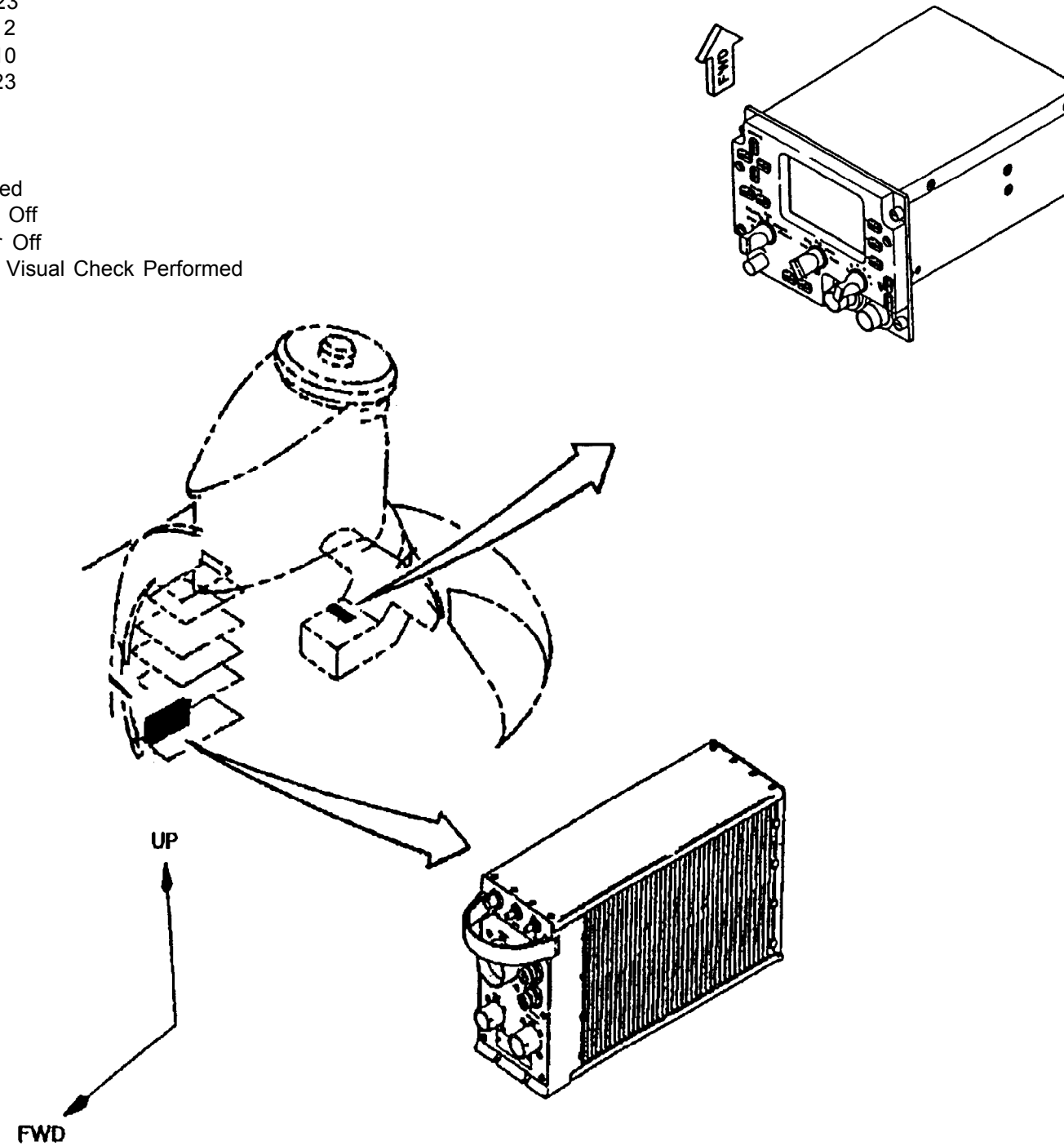

GO TO THE NEXT PAGE

18-4.8 AN/ARC-220 CONTROL DISPLAYS "SYSTEM-NOGO RT-CDU COMM FAIL" DURING RCV OR XMT TEST (CONTINUED).

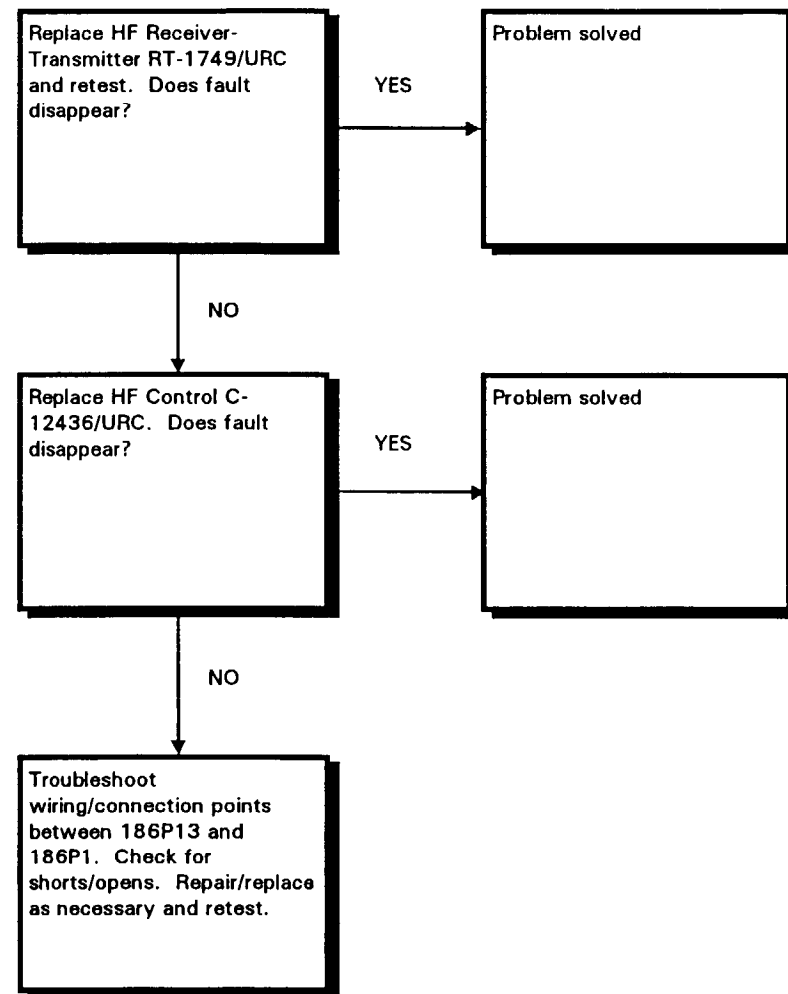

END OF TASK

18-4.9 AN/ARC-220 CONTROL "LOAD FAIL" DURING DATA/KEY FILL).

INITIAL SETUP

Applicable Configurations:

All

Tools:

Electrical Repairer's Tool Kit,
NSN 5180-00-323-4915

Materials:

None

Personnel Required:

Aircraft Electrician (2)

References:

- TM 11-1520-240-23
- TM 11-5821-357-12
- TM 55-1520-240-10
- TM 55-1520-240-23

Equipment Condition:

- TM 55-1520-240-23:
- Battery Connected
- Electrical Power Off
- Hydraulic Power Off
- HF Liaison Facility Visual Check Performed (Task 18-4.2)

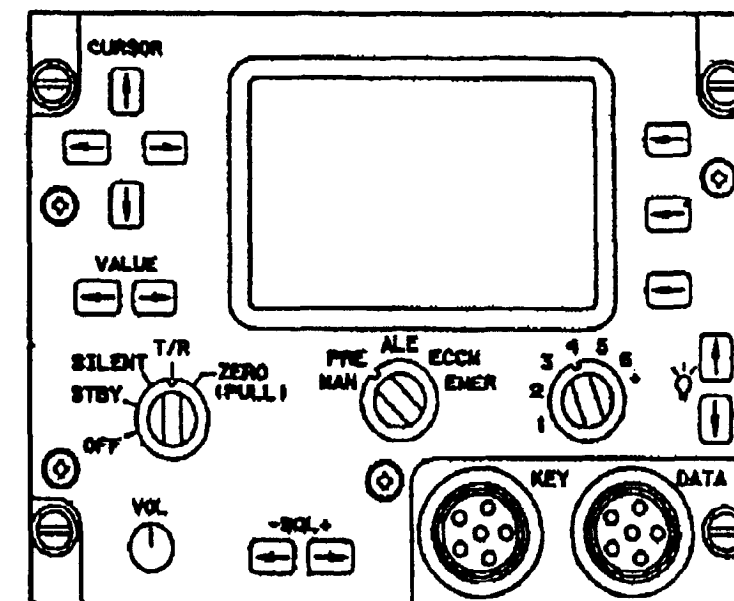
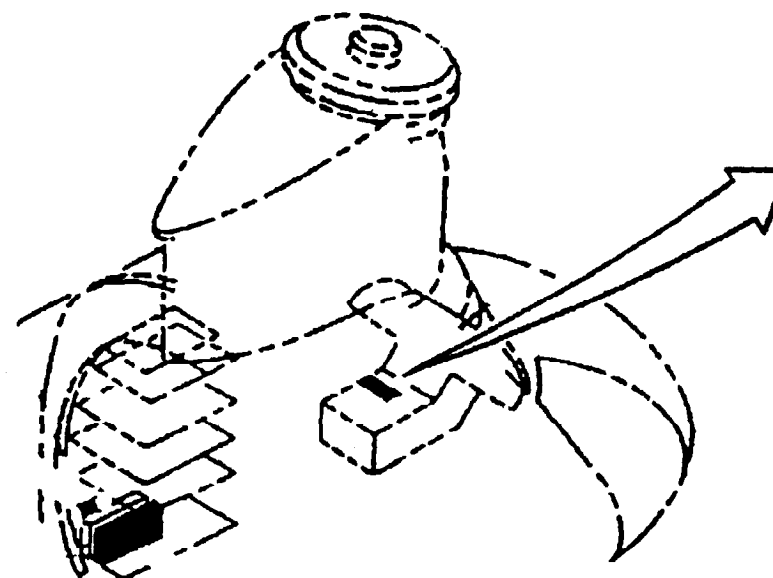

GO TO THE NEXT PAGE

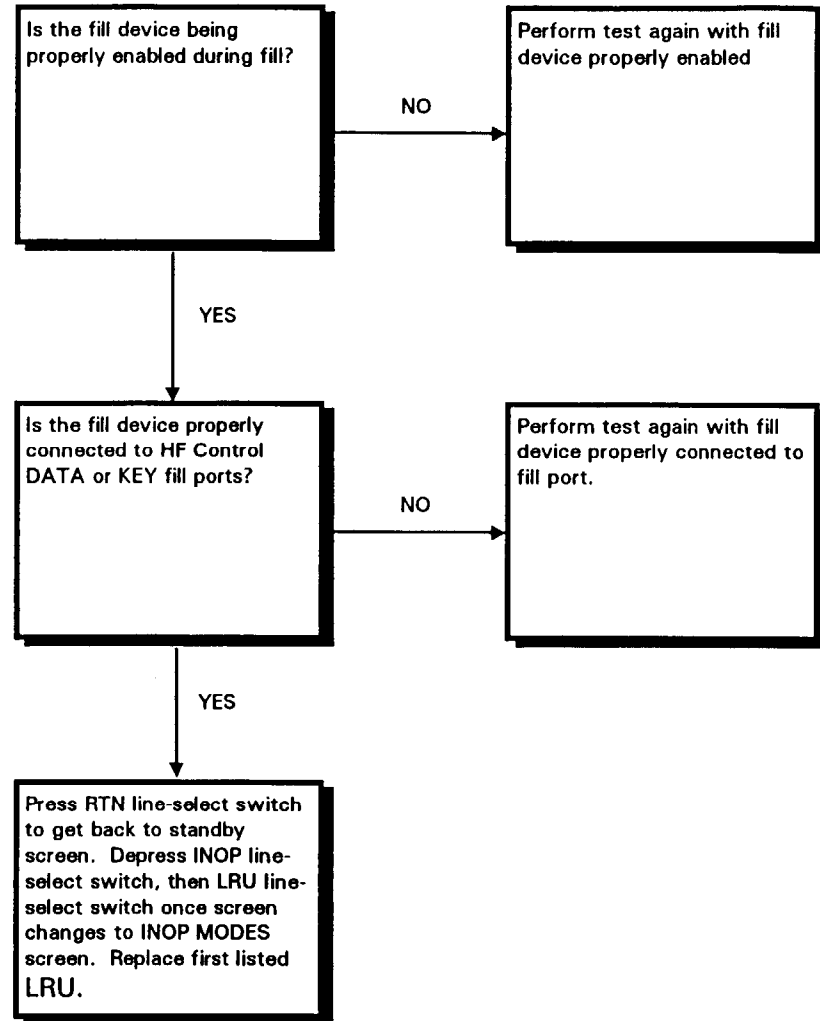

END OF TASK

18-4.10 AN/ARC-220 RECEIVER TRANSMITTER RECEPTION/TRANSMISSION NOT CLEAR OR MISSING IN ALL MODES.

INITIAL SETUP

References:

-Applicable Configurations:

All

TM 11-1520-240-23

TM 11-5821-357-12

TM 55-1520-240-10

TM 55-1520-240-23

Tools:

Electrical Repairer's Tool Kit,
NSN 5180-00-323-4915

Equipment Condition:

TM 55-1520-240-23:

Battery Connected

Electrical Power Off

Hydraulic Power Off

HF Liaison Facility Visual Check Performed

(Task 18-4.2)

Materials:

None

Personnel Required:

Aircraft Electrician (2)

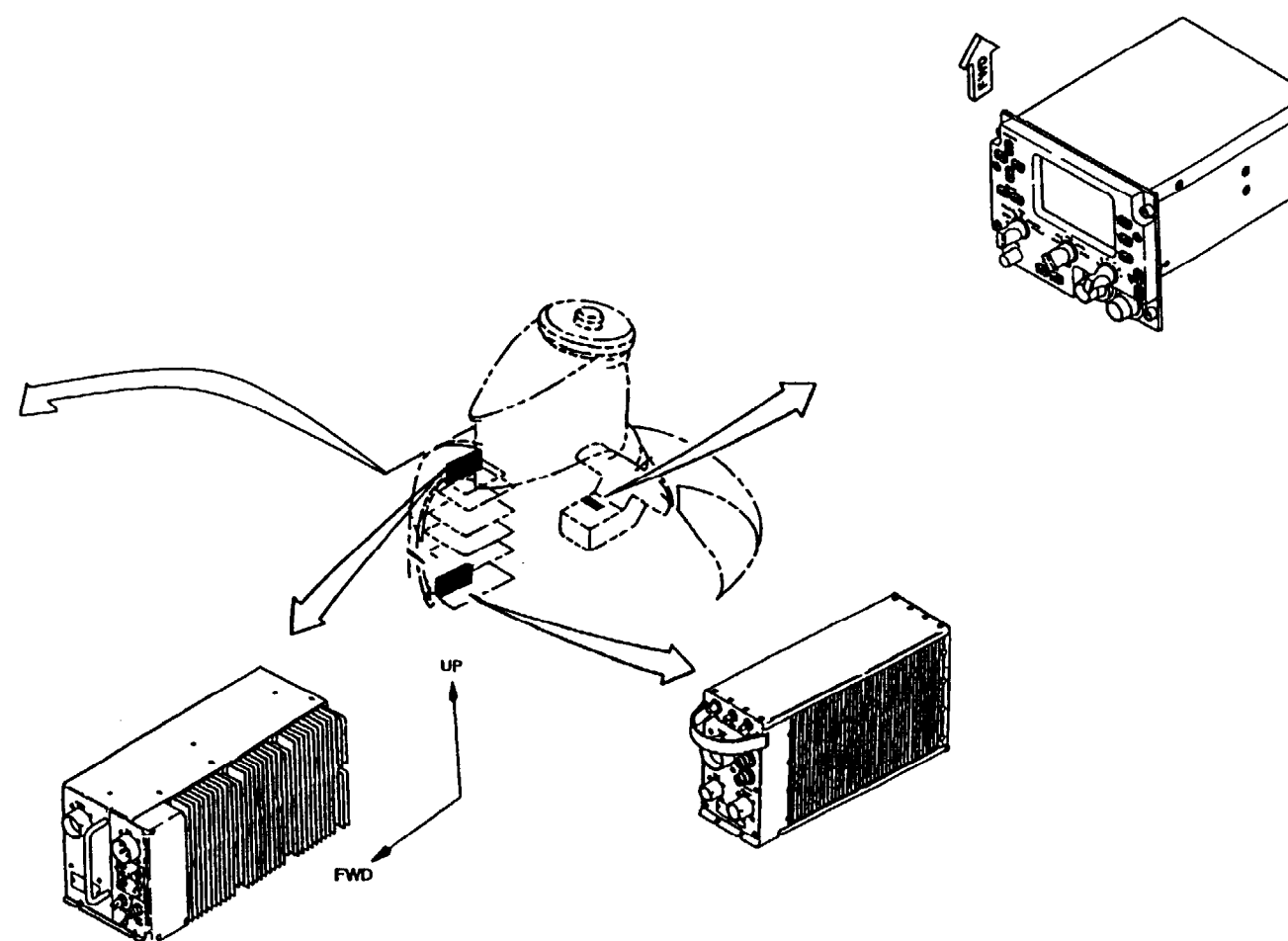
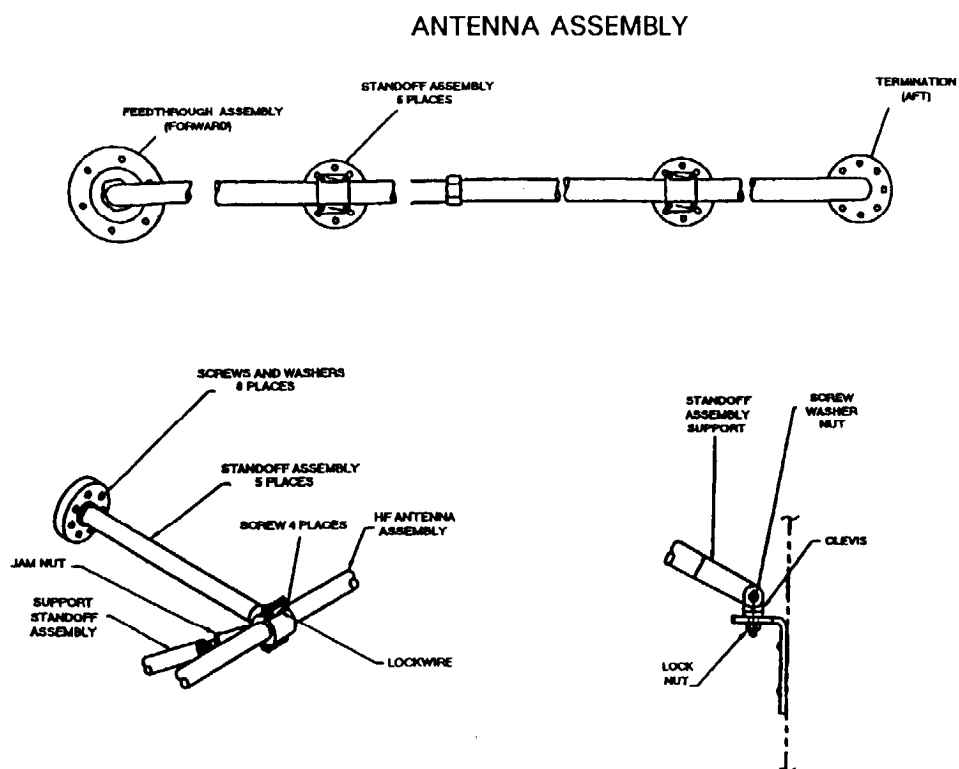

GO TO THE NEXT PAGE

18-4.10 AN/ARC-220 RECEIVER TRANSMITTER RECEPTION/TRANSMISSION NOT CLEAR OR MISSING IN ALL MODES (CONTINUED).

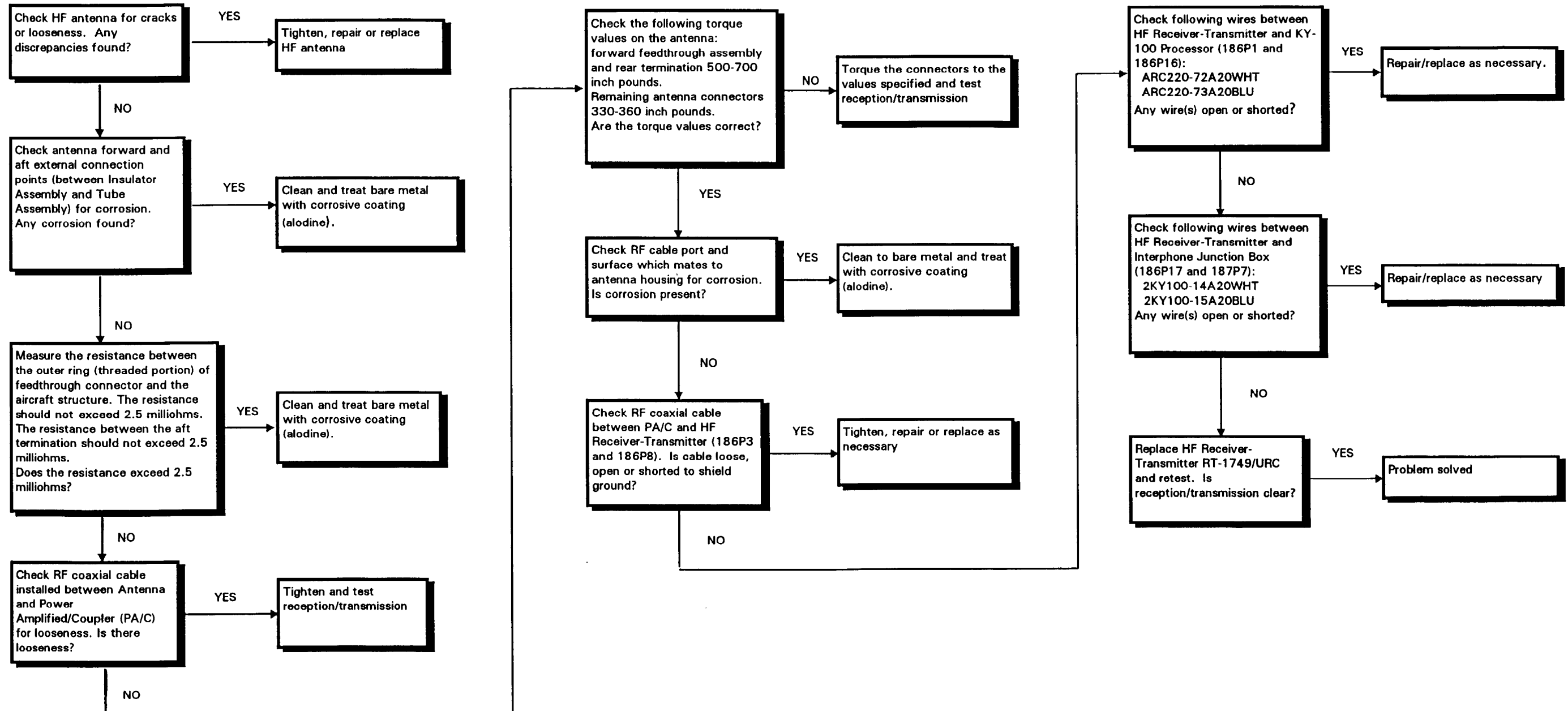

END OF TASK

18-4.11 HF LIAISON FACILITY- "CALL FAIL" DISPLAYED WHEN PLACING ALE OR ECCM CALL

INITIAL SETUP

Applicable Configurations:

All

Tools:

Electrical Repairer's Tool Kit,
NSN 5180-00-323-4915

Materials:

None

Personnel Required:

Aircraft Electrician (2)

References:

- TM 11-1520-240-23
- TM 11-5821-357-12
- TM 55-1520-240-10
- TM 55-1520-240-23

Equipment Condition:

- TM 55-1520-240-23:
 - Battery Connected
 - Electrical Power Off
 - Hydraulic Power Off
 - HF Liaison Facility Visual Check Performed (Task 18-4.2)

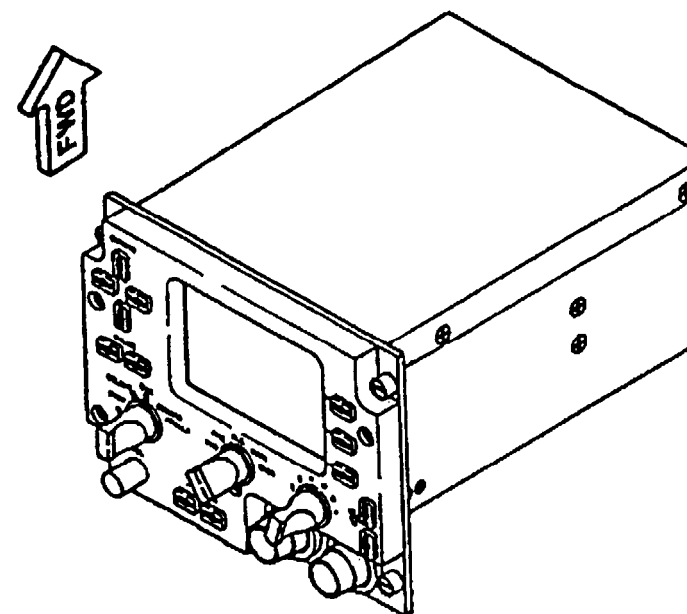
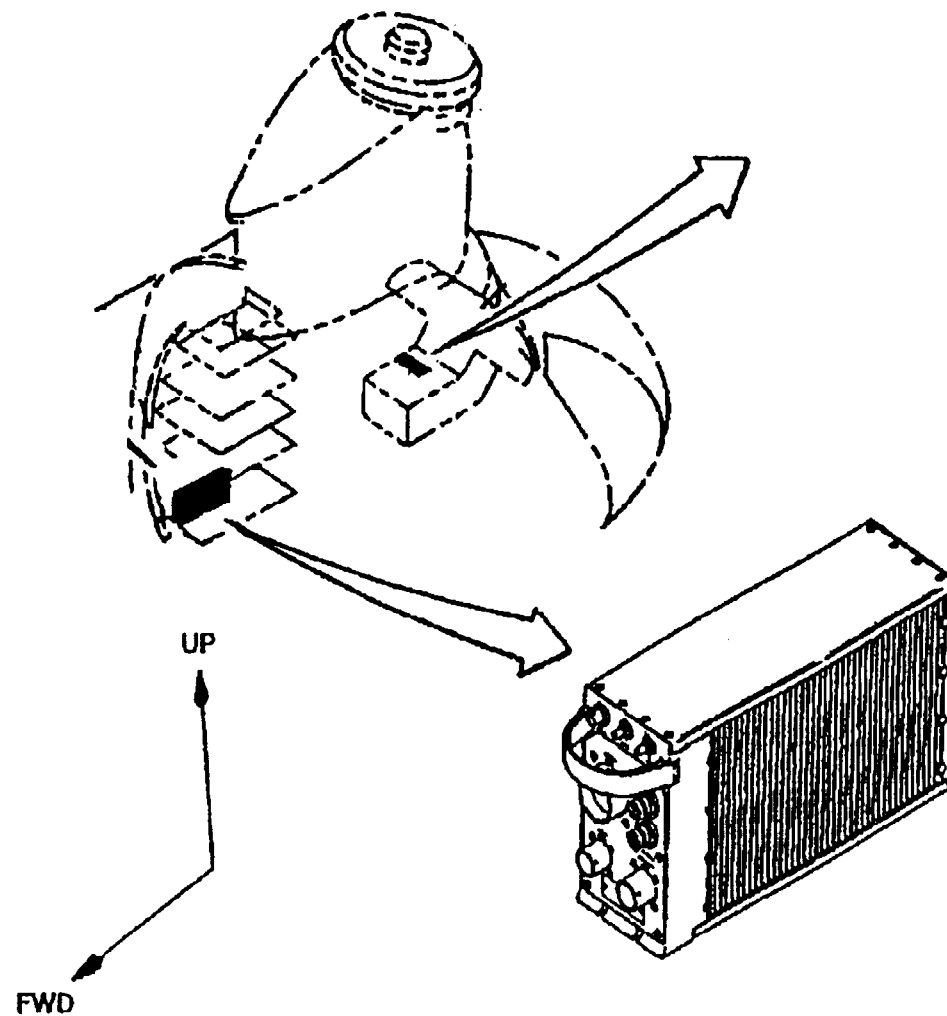

GO TO THE NEXT PAGE

18-4.12 HF LIAISON FACILITY-SYSTEM CANNOT BE TUNED OR SYNCHED DURING ECCM OPERATION

INITIAL SETUP

Applicable Configurations:

All

Tools:

Electrical Repairer's Tool Kit,
NSN 5180-00-323-4915

Materials:

None

Personnel Required:

Aircraft Electrician (2)

References:

- TM 11-1520-240-23
- TM 11-5821-357-12
- TM 55-1520-240-10
- TM 55-1520-240-23

Equipment Condition:

- TM 55-1520-240-23:
- Battery Connected
- Electrical Power Off
- Hydraulic Power Off
- HF Liaison Facility Visual Check Performed (Task 18-4.2)

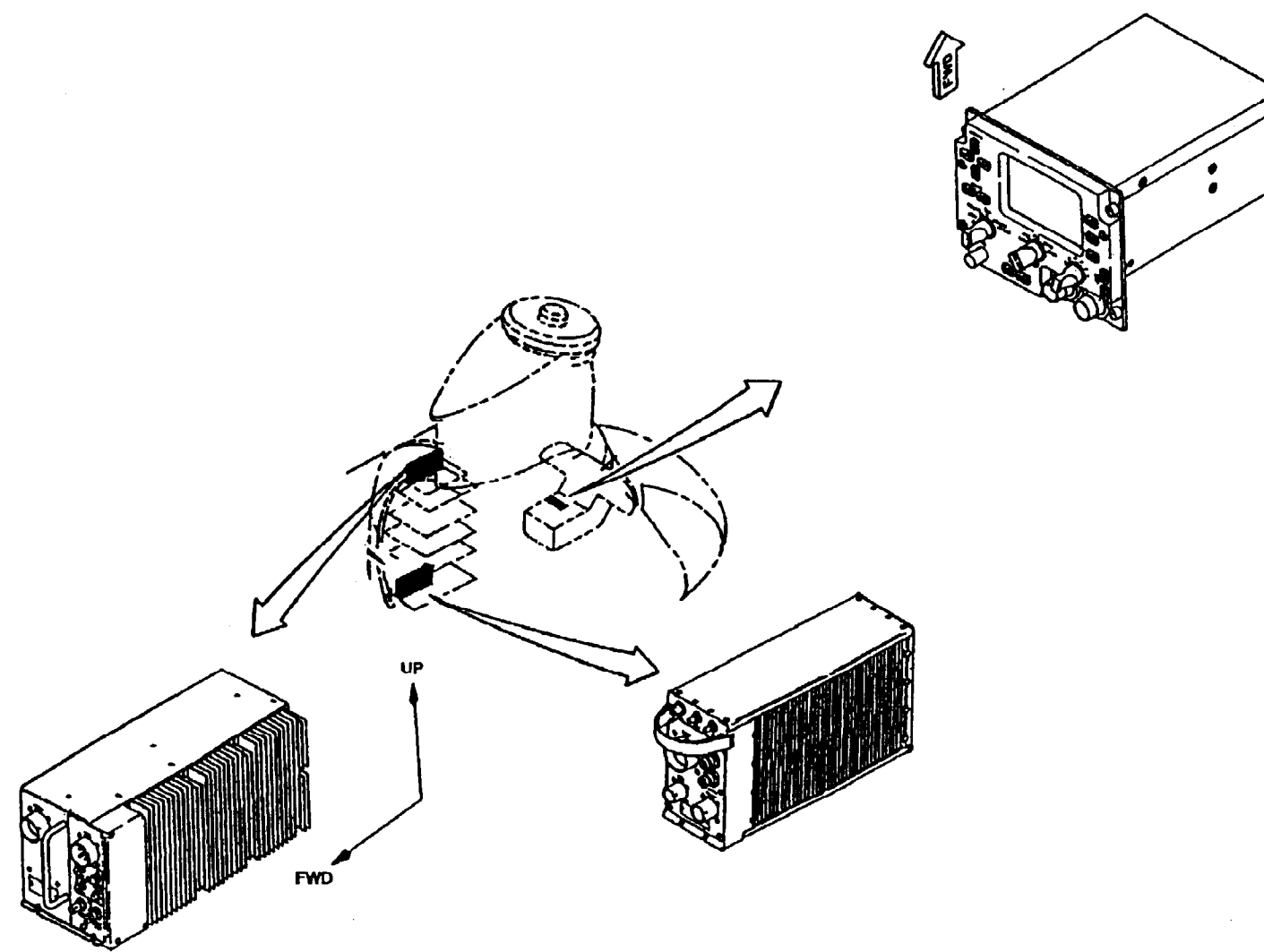

GO TO THE NEXT PAGE

18-4.12 HF LIAISON FACILITY-SYSTEM CANNOT BE TUNED OR SYNCHED DURING ECCM OPERATION (CONTINUED)

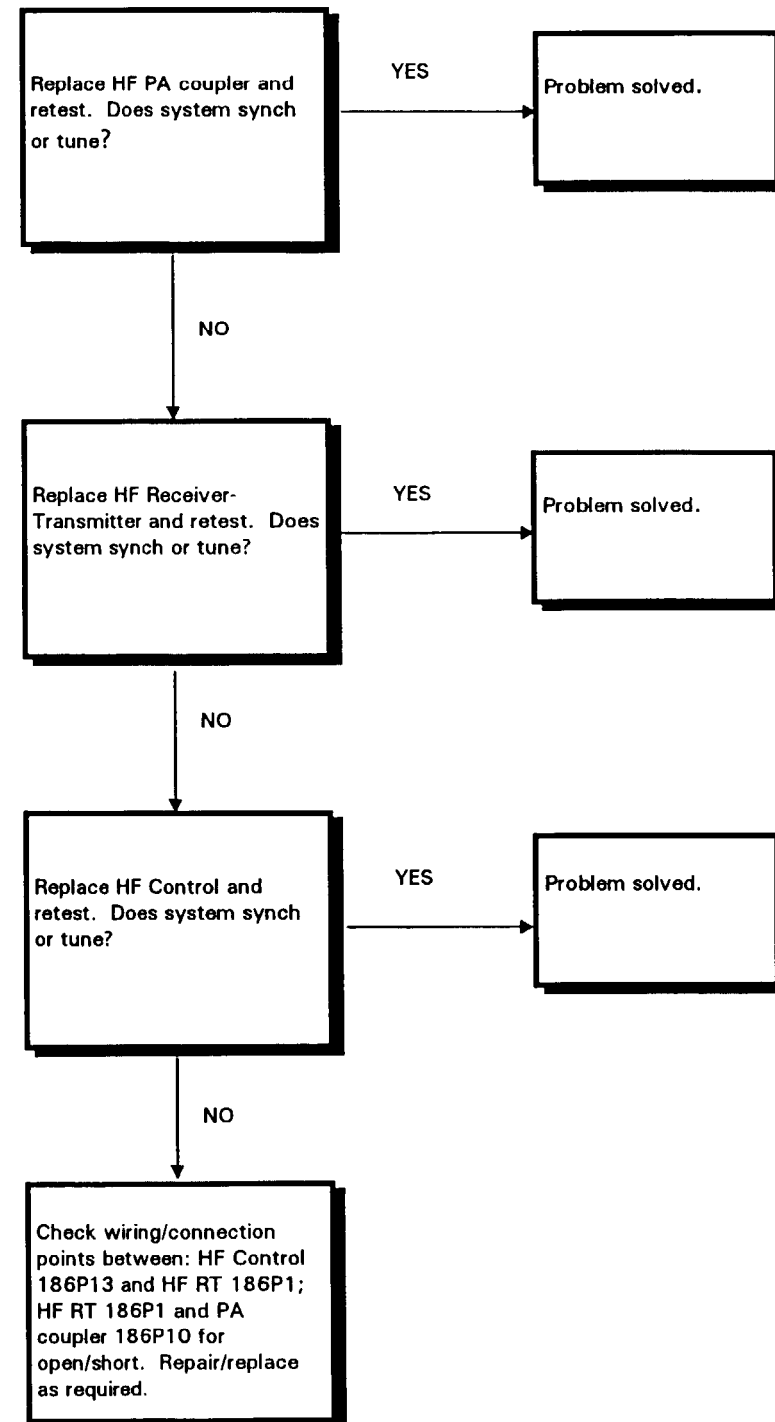

END OF TASK

18-4.13 HF LIAISON FACILITY-PREAMBLE TONES NOT HEARD WHEN PLACING A CALL IN ECCM MODE

INITIAL SETUP

References:

- TM 11-1520-240-23
- TM 11-5821-357-12
- TM 55-1520-240-10
- TM 55-1520-240-23

Applicable Configurations:

All

Tools:

Electrical Repairer's Tool Kit,
NSN 5180-00-323-4915

Materials:

None

Personnel Required:

Aircraft Electrician (2)

Equipment Condition:

- TM 55-1520-240-23:
- Battery Connected
- Electrical Power Off
- Hydraulic Power Off
- HF Liaison Facility Visual Check Performed
(Task 18-4.2)

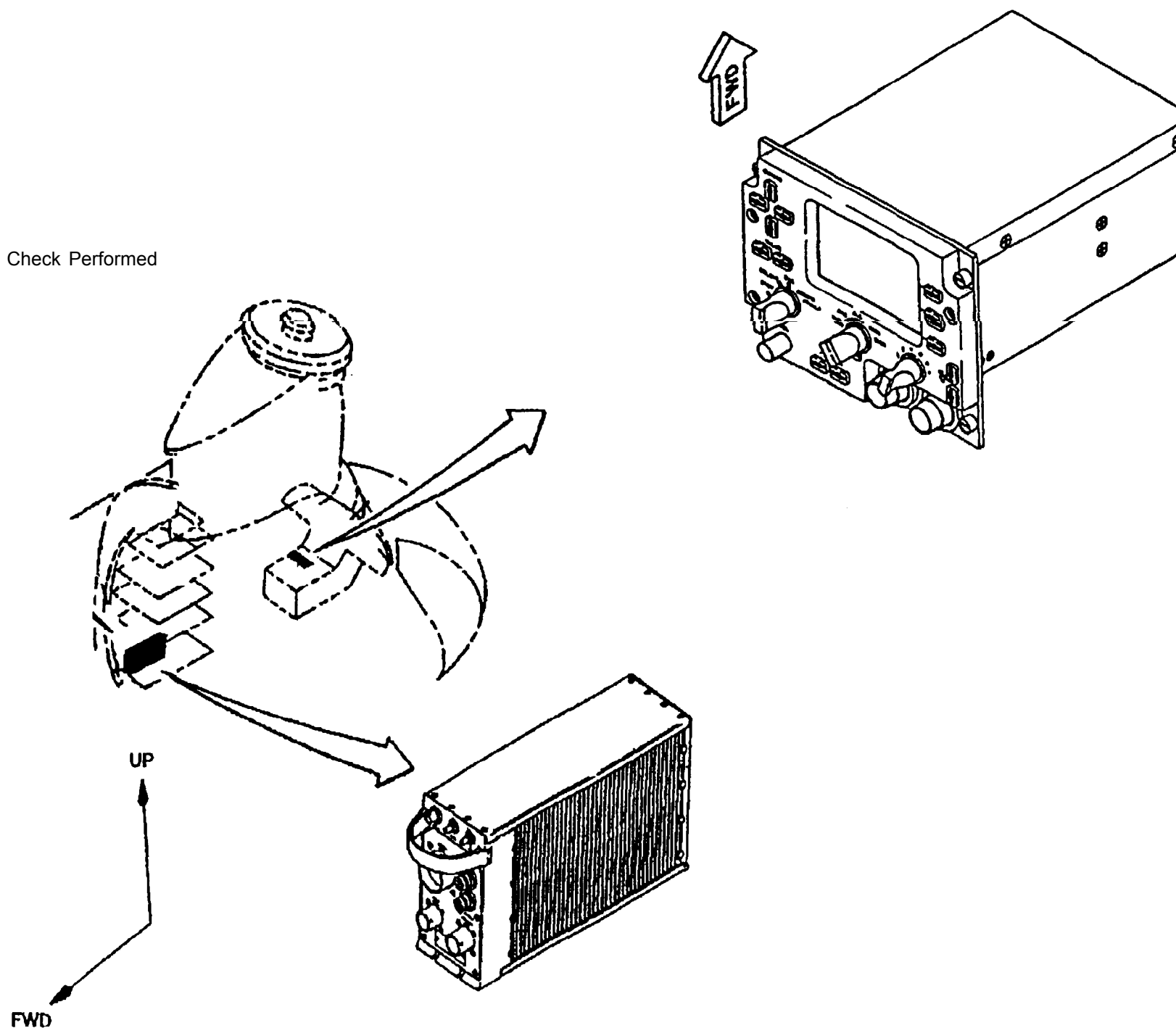

GO TO THE NEXT PAGE

18-4.13 HF LIAISON FACILITY-PREAMBLE TONES NOT HEARD WHEN PLACING A CALL IN ECCM MODE (CONTINUED)

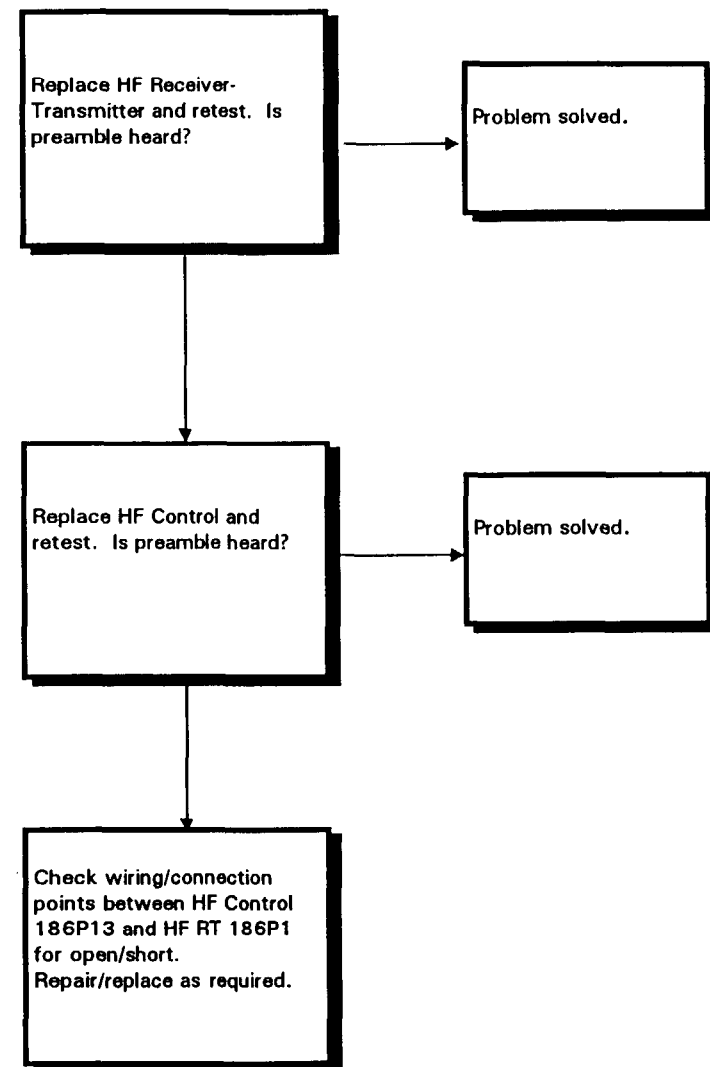

END OF TASK

18-4.14 HF LIAISON FACILITY-"LINKED" IS NOT DISPLAYED ON HF CONTROL WHEN PLACING ALE OR ECCM CALL

INITIAL SETUP

Applicable Configurations:

All

Tools:

Electrical Repairer's Tool Kit,
NSN 5180-00-323-4915

Materials:

None

Personnel Required:

Aircraft Electrician (2)

References:

- TM 11-1520-240-23
- TM 11-5821-357-12
- TM 55-1520-240-10
- TM 55-1520-240-23

Equipment Condition:

- TM 55-1520-240-23:
- Battery Connected
- Electrical Power Off
- Hydraulic Power Off
- HF Liaison Facility Visual Check Performed (Task 18-4.2)

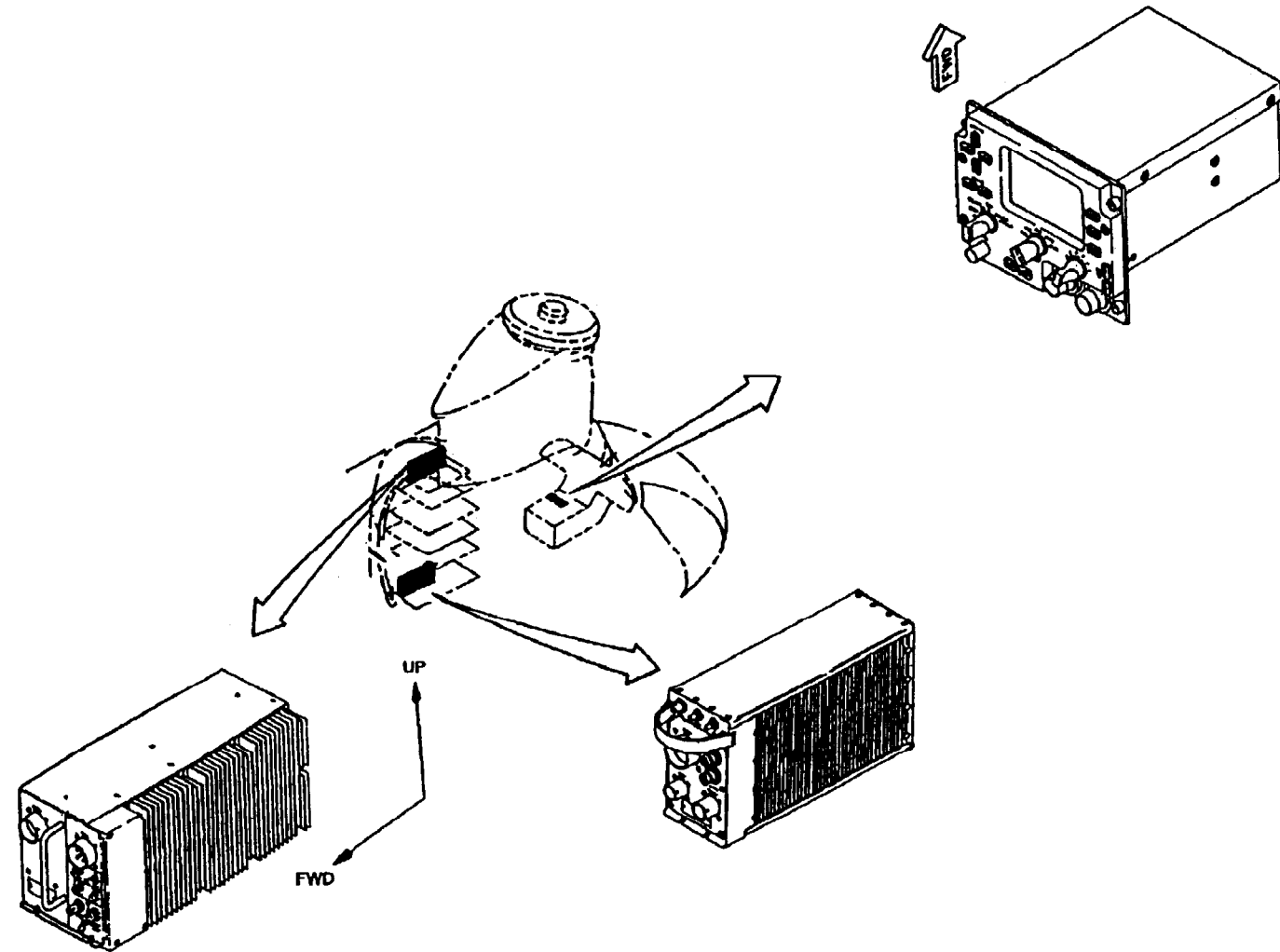

GO TO THE NEXT PAGE

18-4.14 HF LIAISON FACILITY--LINKED" IS NOT DISPLAYED ON HF CONTROL WHEN PLACING ALE OR ECCM CALL (CONTINUED)

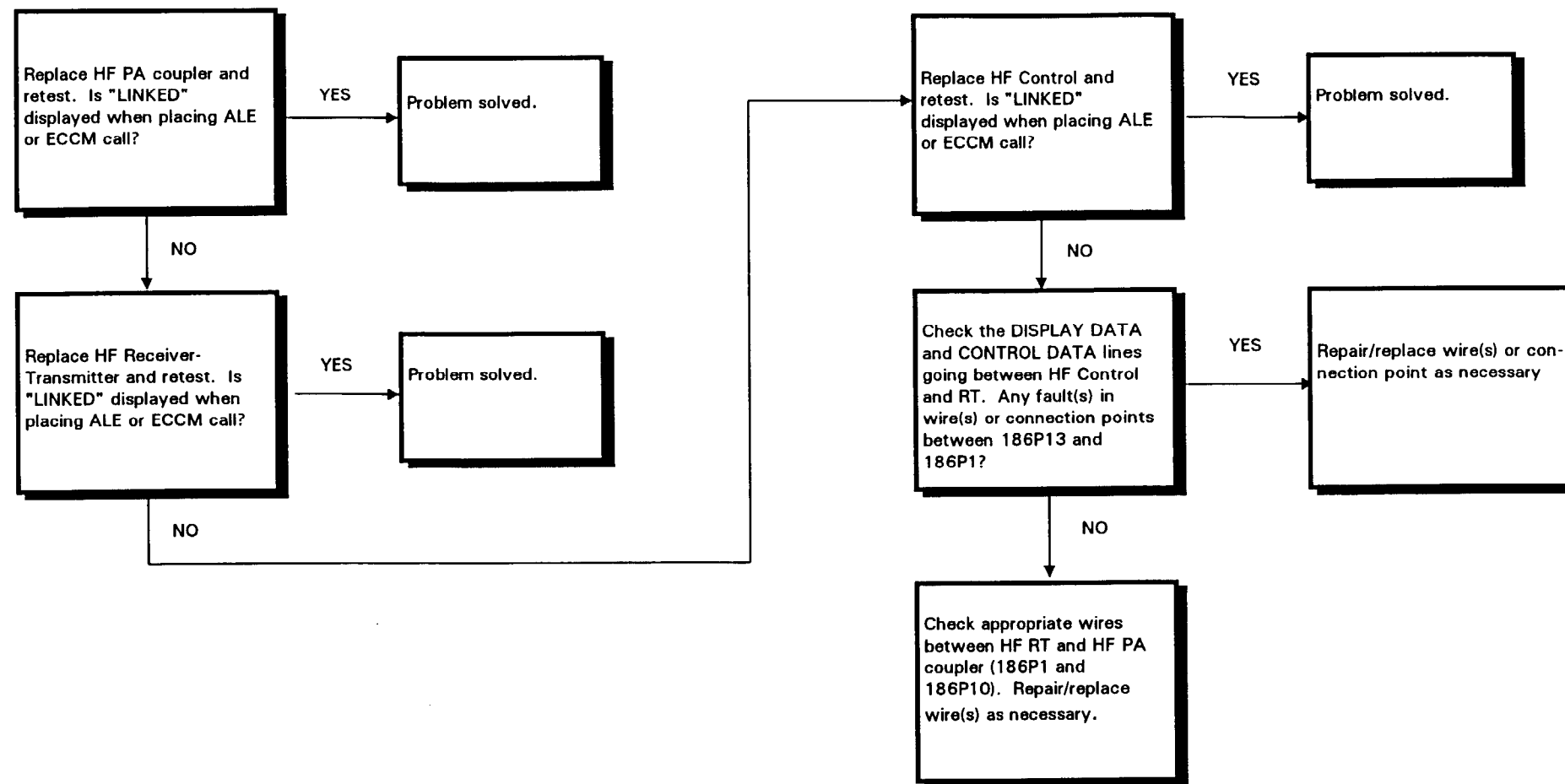

END OF TASK

18-4.15 HF LIAISON FACILITY-HEADSET AUDIO IS NOT RESTORED AFTER LINK ESTABLISHED WHEN PLACING ALE OR ECCM CALL

INITIAL SETUP

Applicable Configurations:
All

Tools:
Electrical Repairer's Tool Kit,
NSN 5180-00-323-4915

Materials:
None

Personnel Required:
Aircraft Electrician (2)

References:

- TM 11-1520-240-23
- TM 11-5821-357-12
- TM 55-1520-240-10
- TM 55-1520-240-23

Equipment Condition:

- TM 55-1520-240-23:
 - Battery Connected
 - Electrical Power Off
 - Hydraulic Power Off
 - HF Liaison Facility Visual Check Performed (Task 18-4.2)

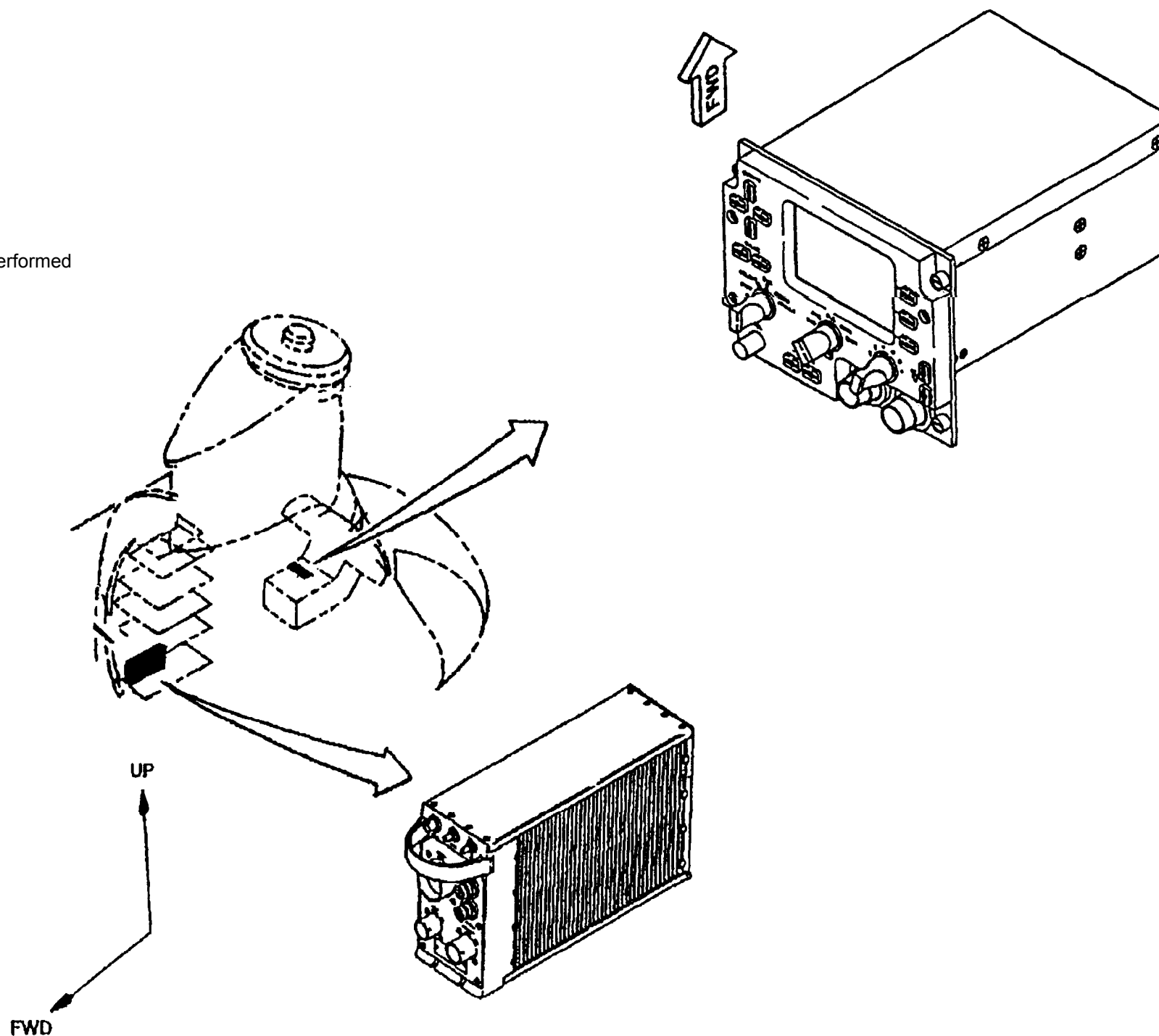

GO TO THE NEXT PAGE

18-4.15 HF LIAISON FACILITY-HEADSET AUDIO IS NOT RESTORED AFTER LINK ESTABLISHED WHEN PLACING ALE OR ECCM CALL (CONTINUED)

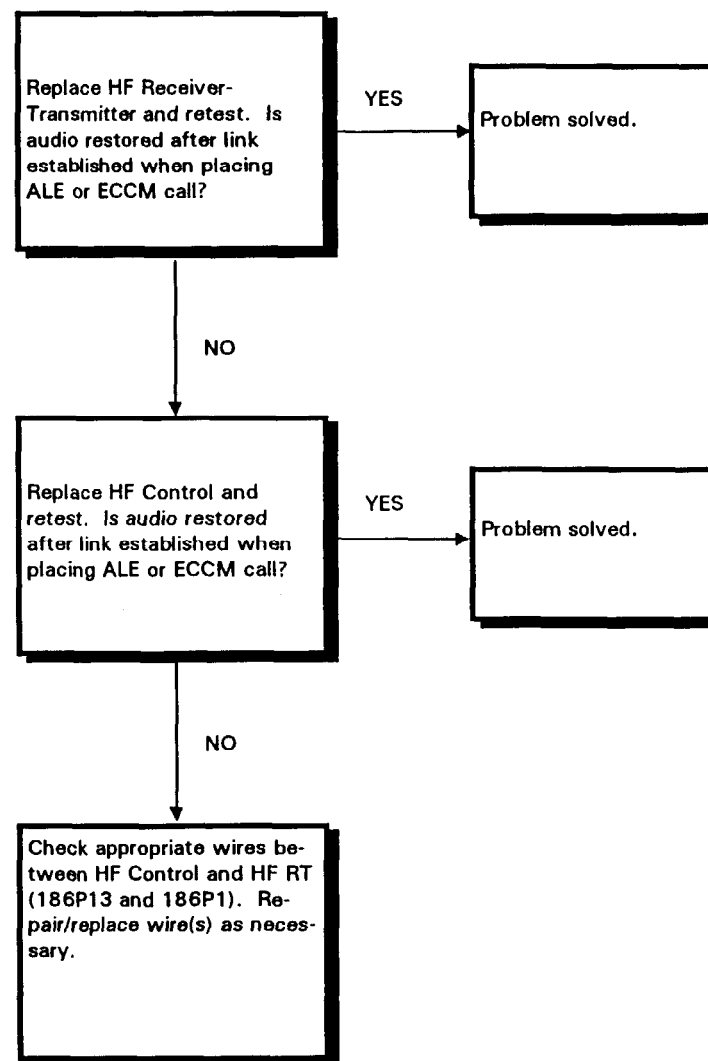

END OF TASK

18-4.16 HF LIAISON FACILITY "RECEIVING PREAMBLE" NOT DISPLAYED BEFORE AN ECCN CALL IS RECEIVED

INITIAL SETUP

Applicable Configurations:

All

Tools:

Electrical Repairer's Tool Kit,
NSN 5180-00-323-4915

Materials:

None

Personnel Required:

Aircraft Electrician (2)

References:

- TM 11-1520-240-23
- TM 11-5821-357-12
- TM 55-1520-240-10
- TM 55-1520-240-23

Equipment Condition:

- TM 55-1520-240-23:
- Battery Connected
- Electrical Power Off
- Hydraulic Power Off
- HF Liaison Facility Visual Check Performed
(Task 18-4.2)

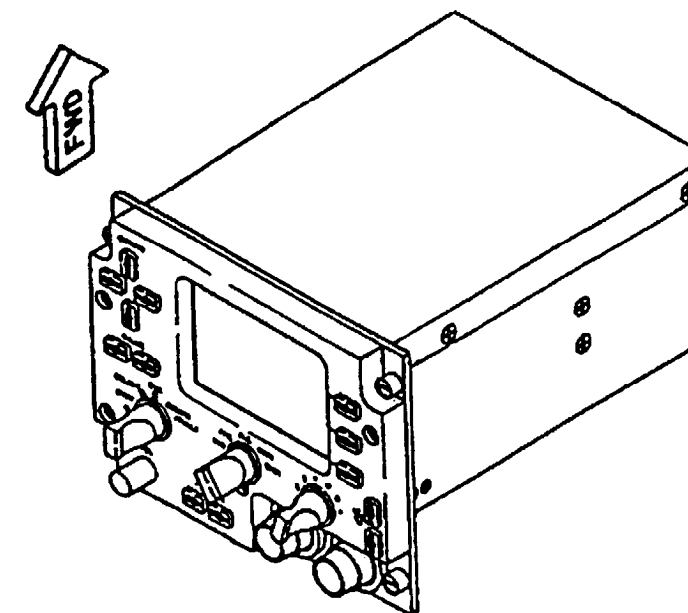
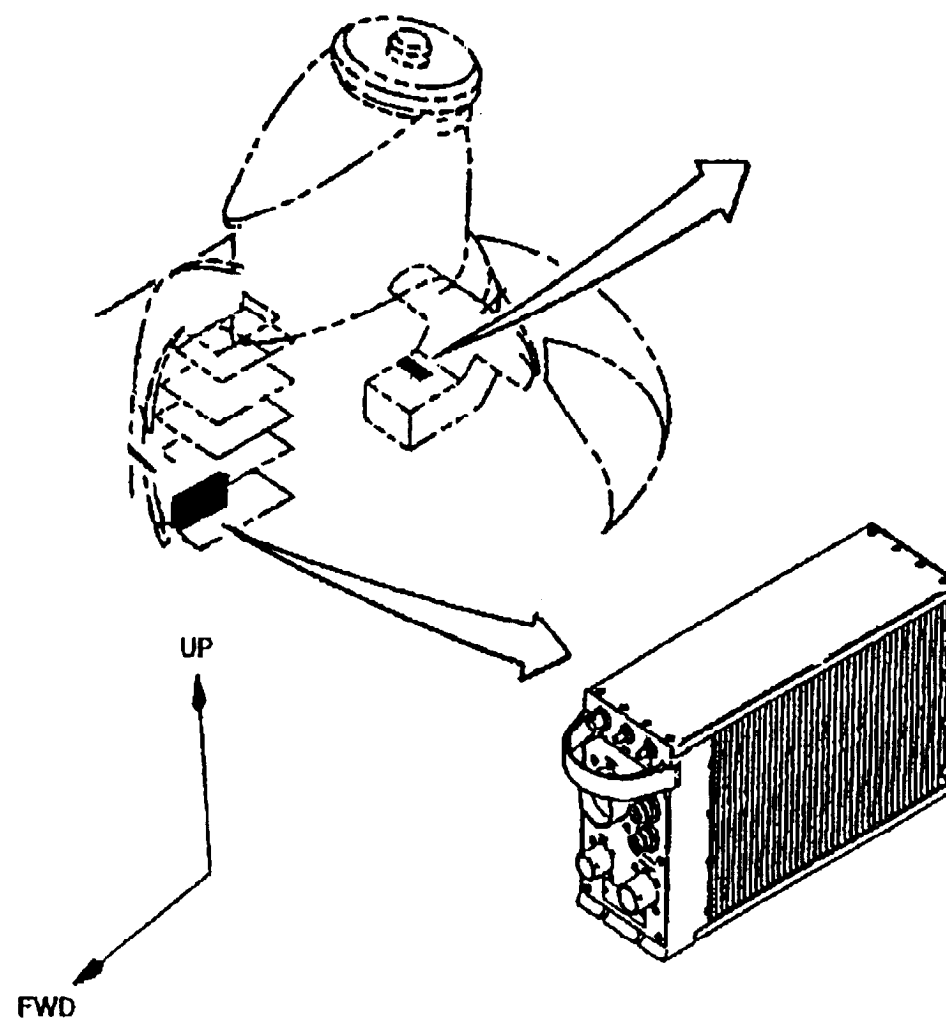

GO TO THE NEXT PAGE

18-4.16 HF LIAISON FACILITY "RECEIVING PREAMBLE" NOT DISPLAYED BEFORE AN ECCN CALL IS RECEIVED (CONTINUED)

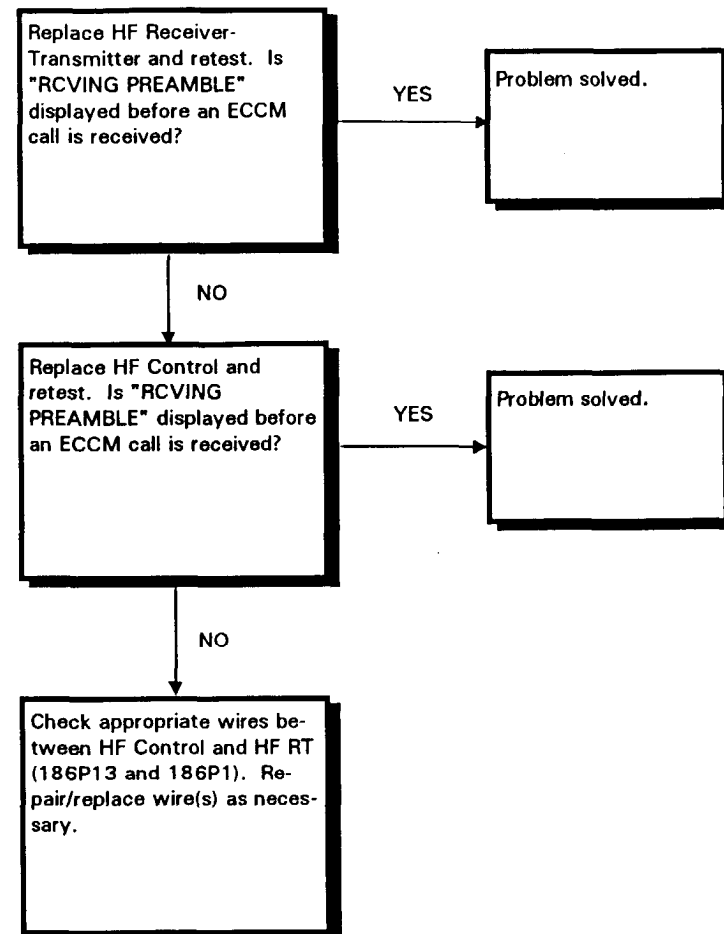

END OF TASK

18-4.17 HF LIAISON FACILITY - PREPROGRAMED INFORMATION CANNOT BE ZEROIZED

INITIAL SETUP

Applicable Configurations:

All

Tools:

Electrical Repairer's Tool Kit,
NSN 5180-00-323-4915

Materials:

None

Personnel Required:

Aircraft Electrician (2)

References:

- TM 11-1520-240-23
- TM 11-5821-357-12
- TM 55-1520-240-10
- TM 55-1520-240-23

Equipment Condition:

- TM 55-1520-240-23:
- Battery Connected
- Electrical Power Off
- Hydraulic Power Off
- HF Liaison Facility Visual Check Performed
(Task 18-4.2)

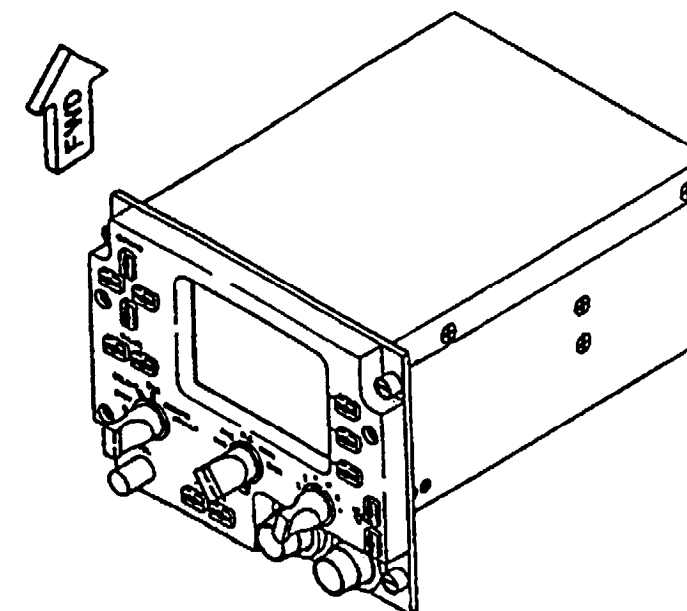
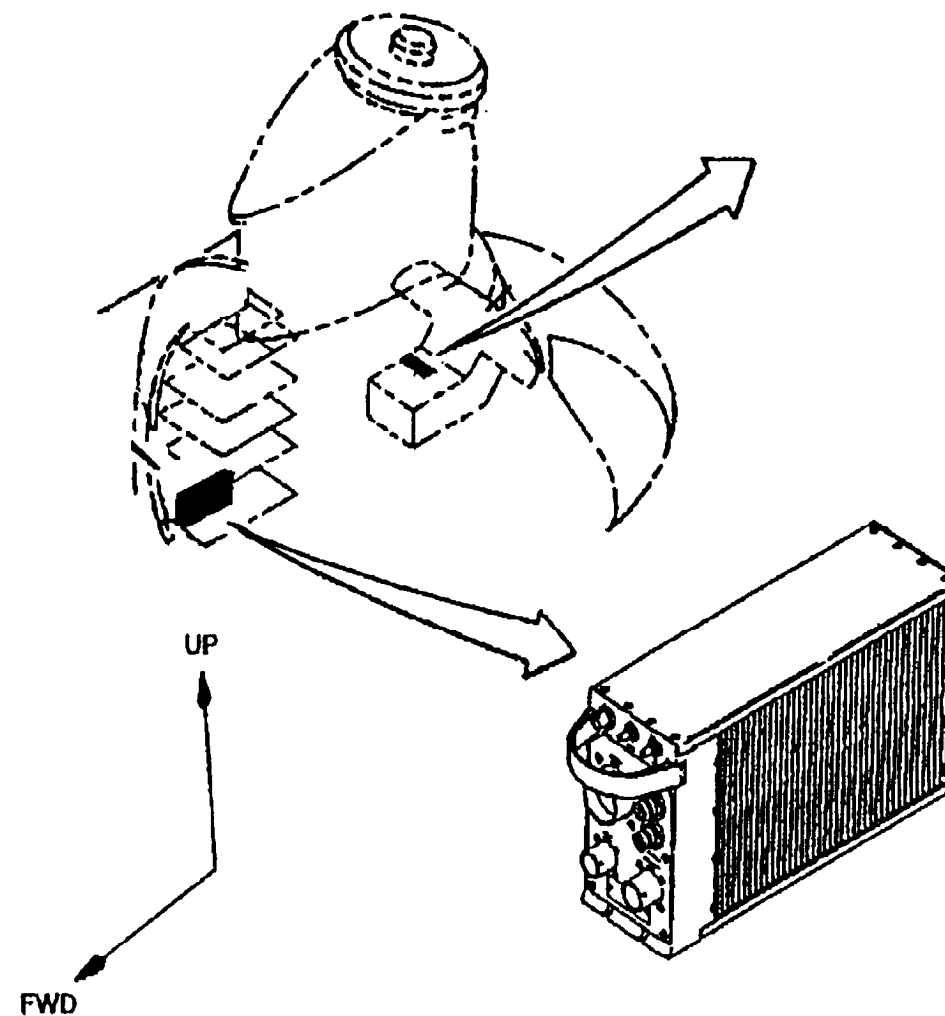

GO TO THE NEXT PAGE

18-4.17 HF LIAISON FACILITY - PREPROGRAMED INFORMATION CANNOT BE ZEROIZED
(CONTINUED)

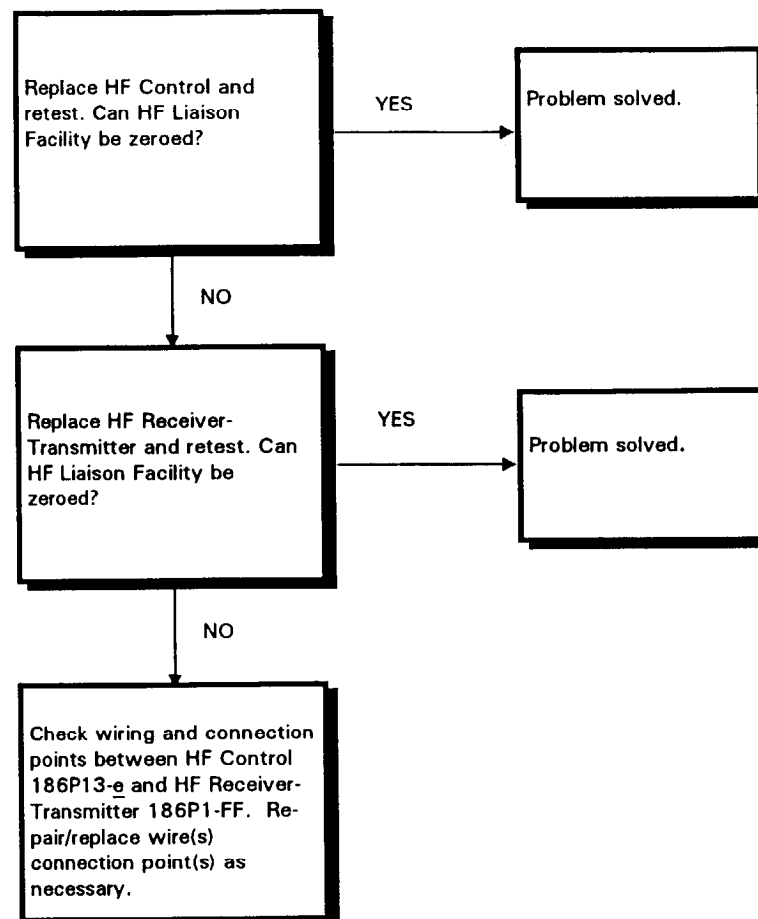

END OF TASK

18-4.18 TESC/KY-100 CONTROL RCU CANNOT KEY FILL FROM KEY FILL DEVICE

INITIAL SETUP

Applicable Configurations:

All

Tools:

Electrical Repairer's Tool Kit,
NSN 5180-00-323-4915

Materials:

None

Personnel Required:

Aircraft Electrician (2)

References:

- TM 11-1520-240-23
- TM 11-5821-357-12
- TM 55-1520-240-10
- TM 55-1520-240-23

Equipment Condition:

- TM 55-1520-240-23:
- Battery Connected
- Electrical Power Off
- Hydraulic Power Off
- HF Liaison Facility Visual Check Performed
(Task 18-4.2)

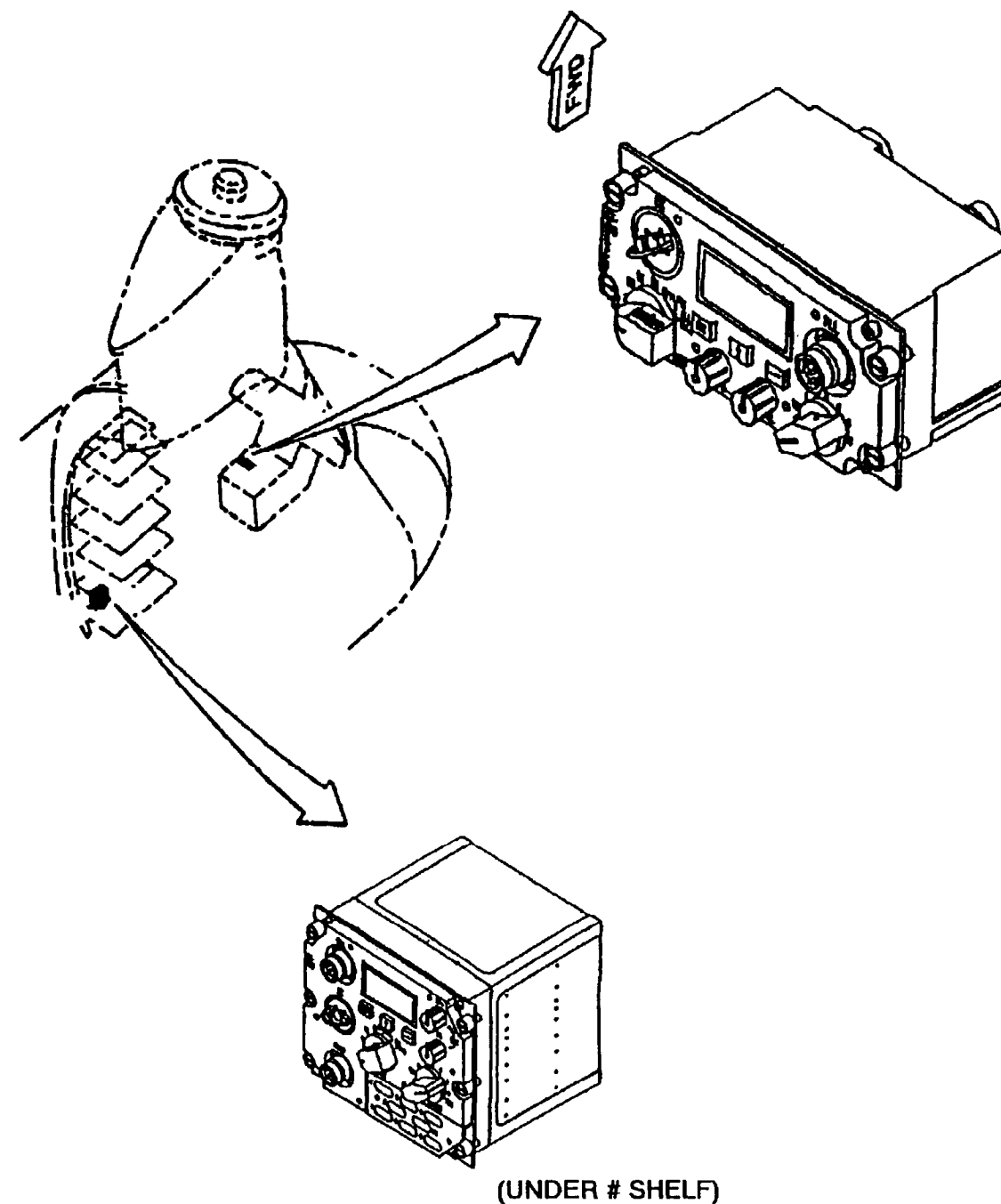

GO TO THE NEXT PAGE

18-4.18 TSEC/KY-100 CONTROL RCU CANNOT KEY FILL FROM KEY FILL DEVICE
(CONTINUED)

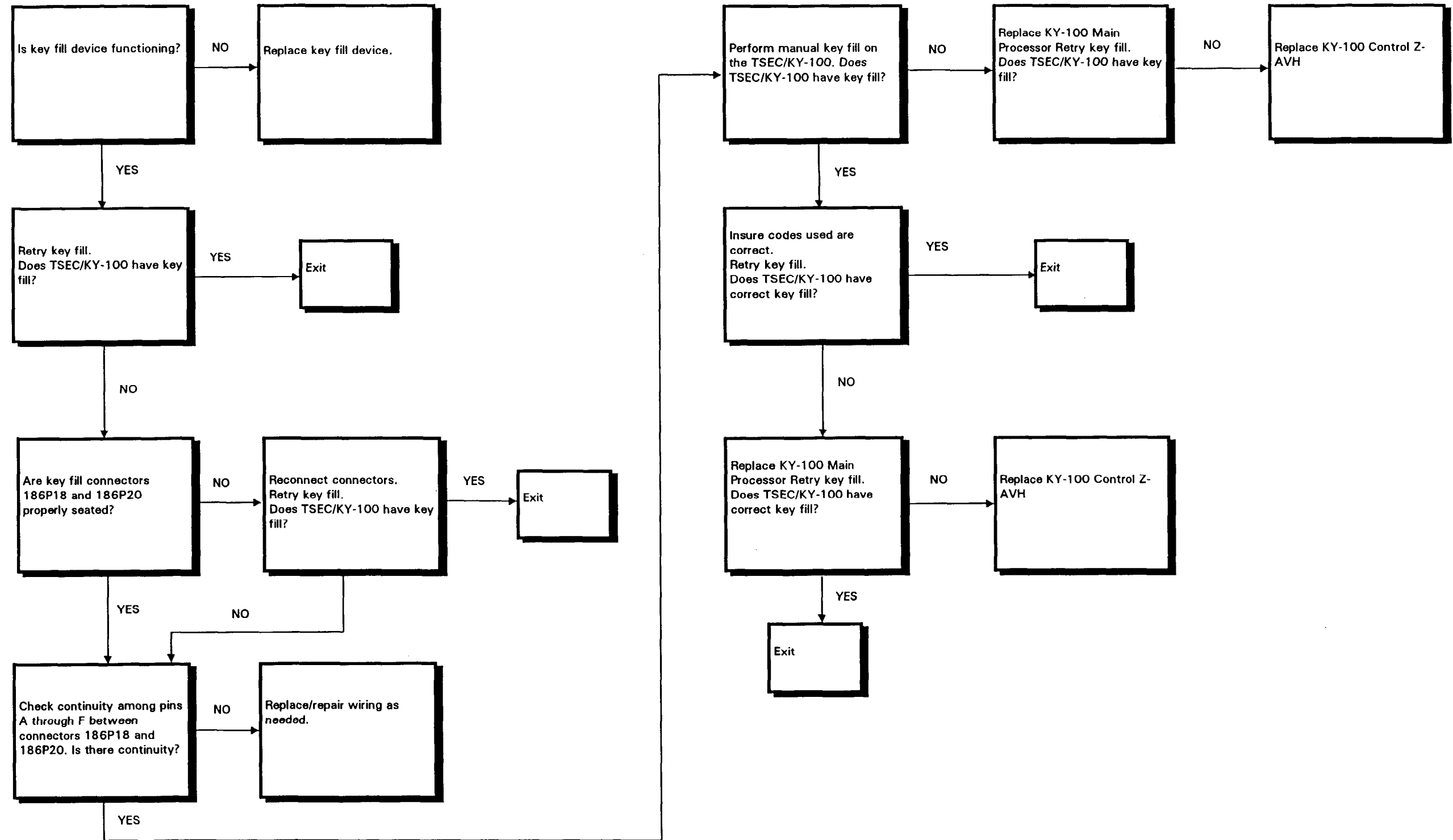

END OF TASK

18-4.19 TESC/KY-100 CONTROL RCU CANNOT KEYS CANNOT BE ZEROED

INITIAL SETUP

Applicable Configurations:
All

Tools:
Electrical Repairer's Tool Kit,
NSN 5180-00-323-4915

Materials:
None

Personnel Required;
Aircraft Electrician (2)

References:

- TM 11-1520-240-23
- TM 11-5821-357-12
- TM 55-1520-240-10
- TM 55-1520-240-23

Equipment Condition:

- TM 55-1520-240-23:
- Battery Connected
- Electrical Power Off
- Hydraulic Power Off
- HF Liaison Facility Visual Check Performed
(Task 18-4.2)

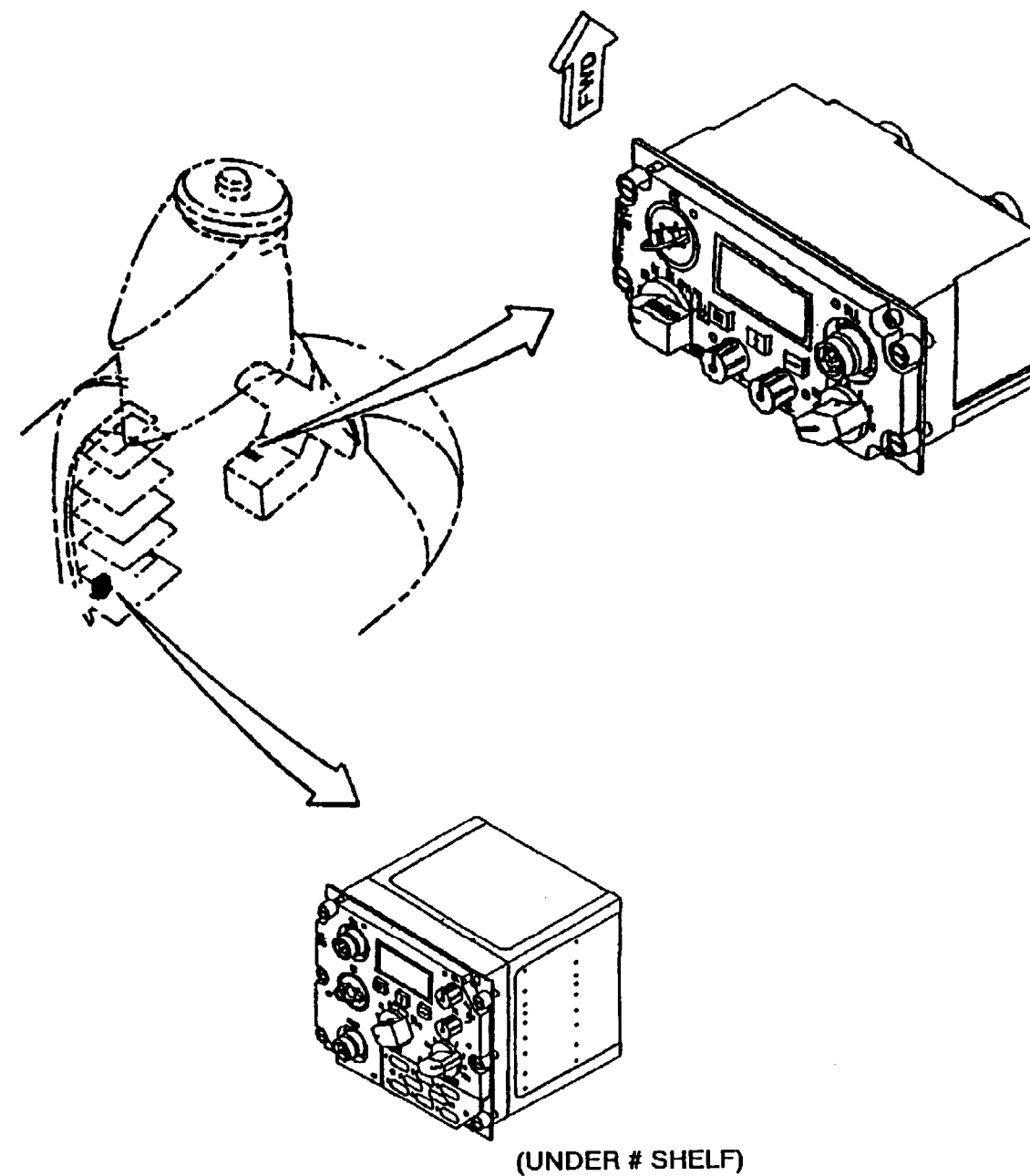

GO TO THE NEXT PAGE

18-4.19 TESC/KY-100 CONTROL RCU CANNOT KEYS CANNOT BE ZEROED (CONTINUED)

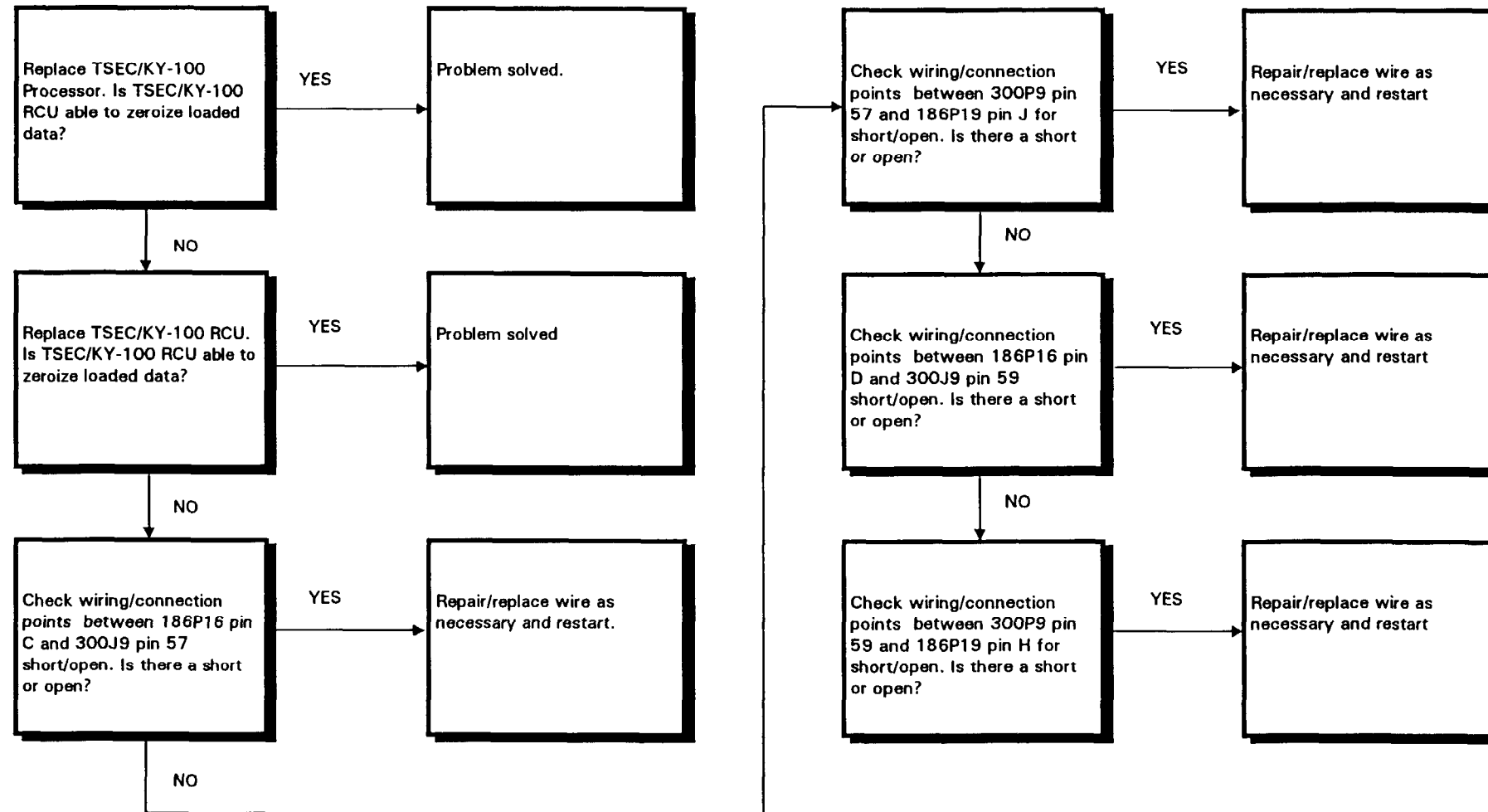

END OF TASK

18-4.20 SECURE VOICE OPERATION - WITH KY-100 CONTROL SET TO CT MODE AND PLAINTEXT TRANSMITTED TO RADIO UNDER TEST, COMMUNICATION NOT HEARD

INITIAL SETUP

Applicable Configurations:

All

Tools:

Electrical Repairer's Tool Kit,
NSN 5180-00-323-4915

Materials:

None

Personnel Required:

Aircraft Electrician (2)

References:

- TM 11-1520-240-23
- TM 11-5821-357-12
- TM 55-1520-240-10
- TM 55-1520-240-23

Equipment Condition:

- TM 55-1520-240-23:
- Battery Connected
- Electrical Power Off
- Hydraulic Power Off
- HF Liaison Facility Visual Check Performed (Task 18-4.2)

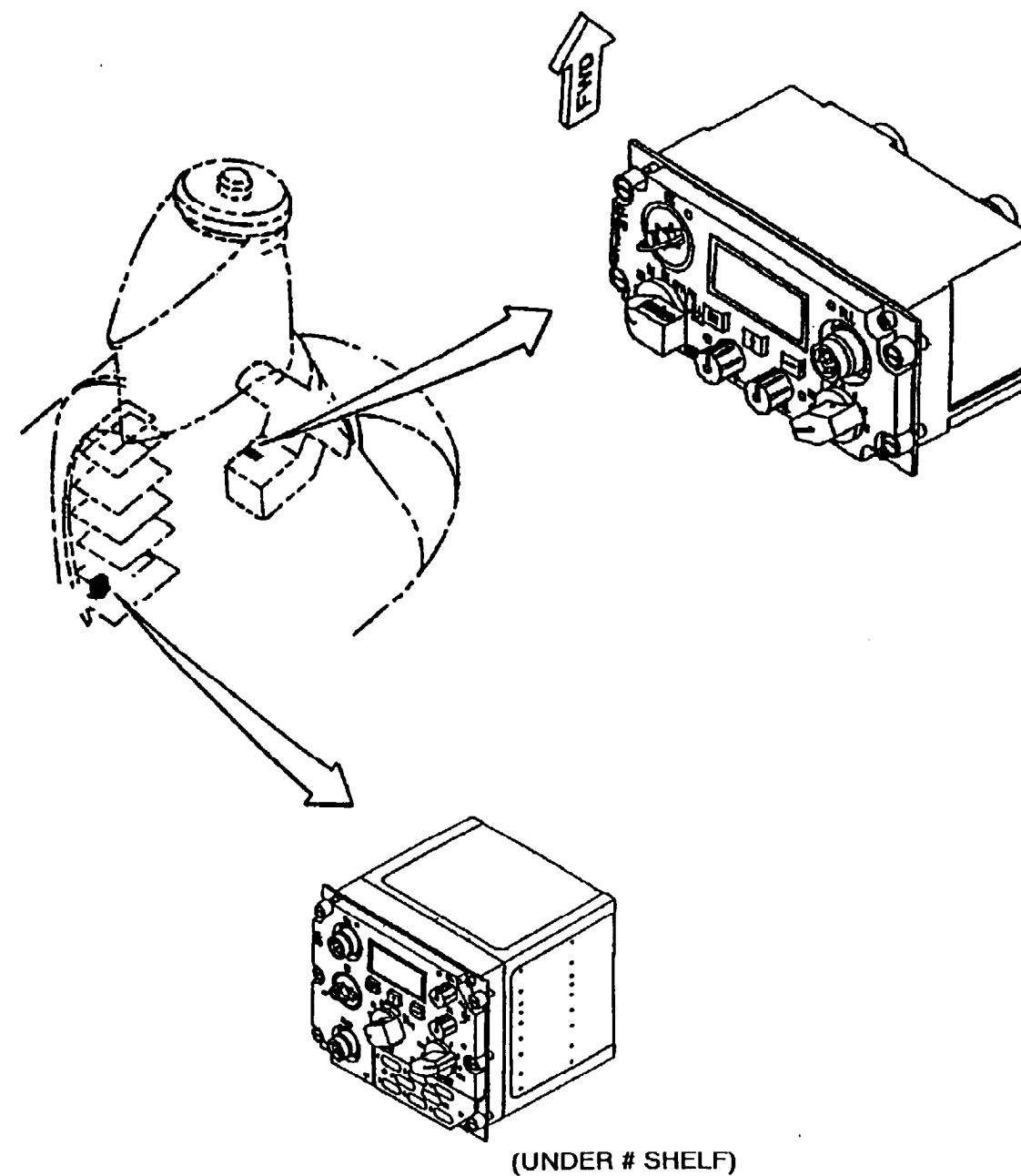

GO TO THE NEXT PAGE

18-4.20 SECURE VOICE OPERATION - WITH KY-100 CONTROL SET TO CT MODE AND PLAINTEXT TRANSMITTED TO RADIO UNDER TEST, COMMUNICATION NOT HEARD (CONTINUED)

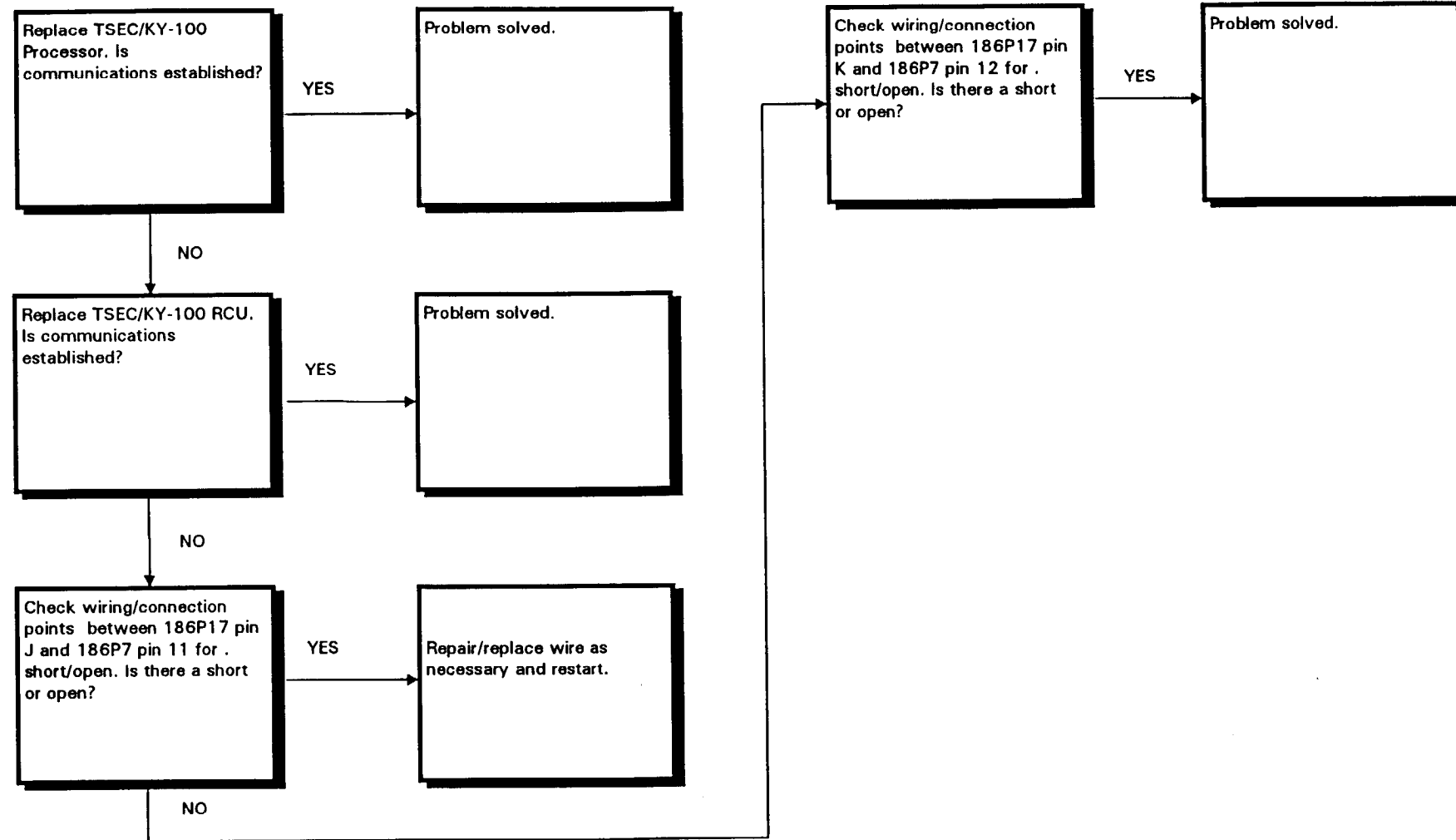

END OF TASK

18-4.21 SECURE VOICE OPERATION - WITH KY-100 CONTROL SET TO VARIOUS POSITIONS AND BOTH CIPHERTEXT AND PLAINTEXT TRANSMITTED TO RADIO UNDER TEST ABNORMAL COMMUNICATIONS AND ANNUNCIATOR OCCUR

INITIAL SETUP

Applicable Configurations:

All

Tools:

Electrical Repairer's Tool Kit,
NSN 5180-00-323-4915

Materials:

None

Personnel Required:

Aircraft Electrician (2)

References:

- TM 11-1520-240-23
- TM 11-5821-357-12
- TM 55-1520-240-10
- TM 55-1520-240-23

Equipment Condition:

- TM 55-1520-240-23:
- Battery Connected
- Electrical Power Off
- Hydraulic Power Off
- HF Liaison Facility Visual Check Performed (Task 18-4.2)

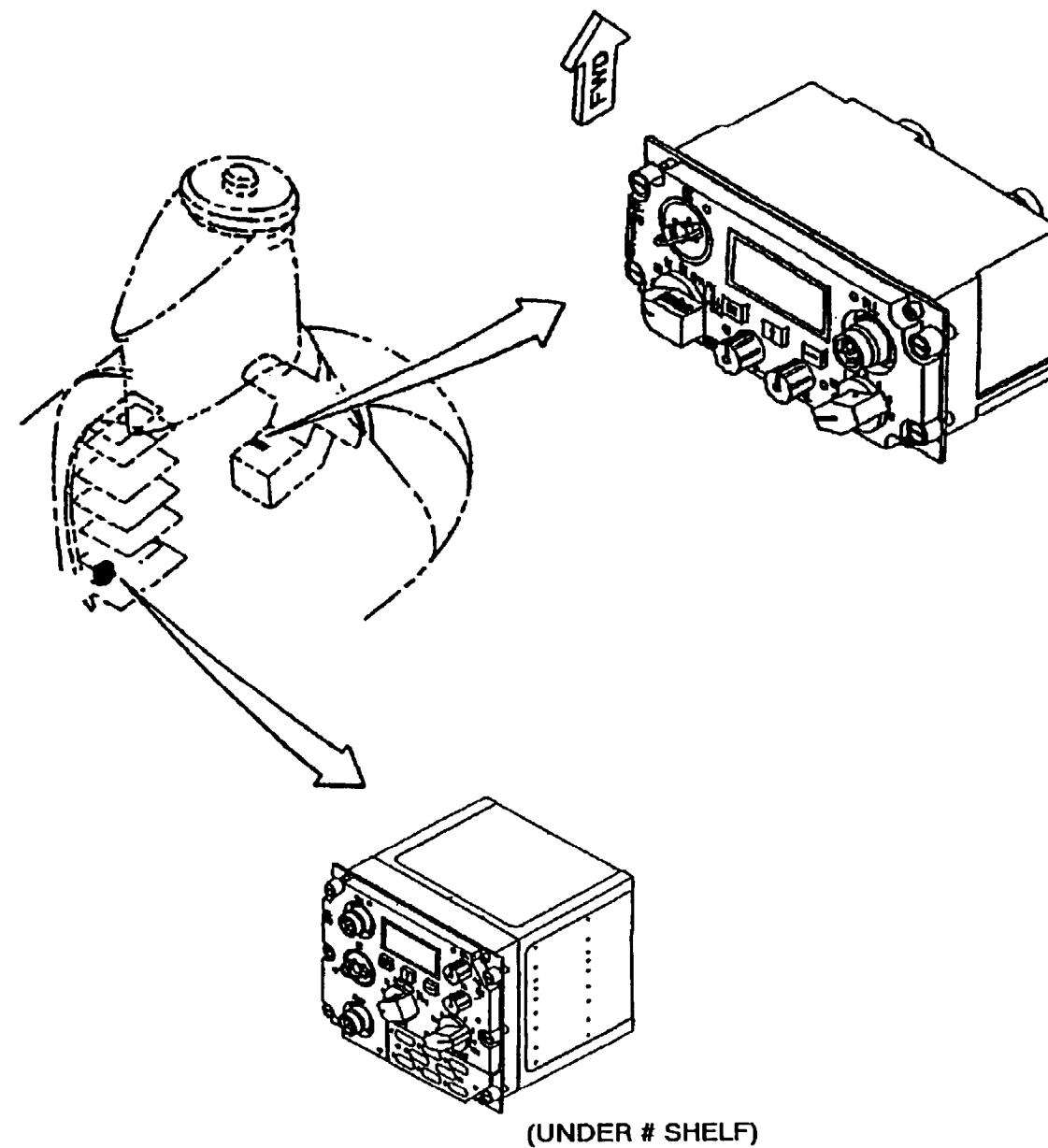

GO TO THE NEXT PAGE

18-4.21 SECURE VOICE OPERATION - WITH KY-100 CONTROL SET TO VARIOUS POSITIONS AND BOTH CIPHERTEXT AND PLAINTEXT TRANSMITTED TO RADIO UNDER TEST ABNORMAL COMMUNICATIONS AND ANNUNCIATOR OCCUR (CONTINUED)

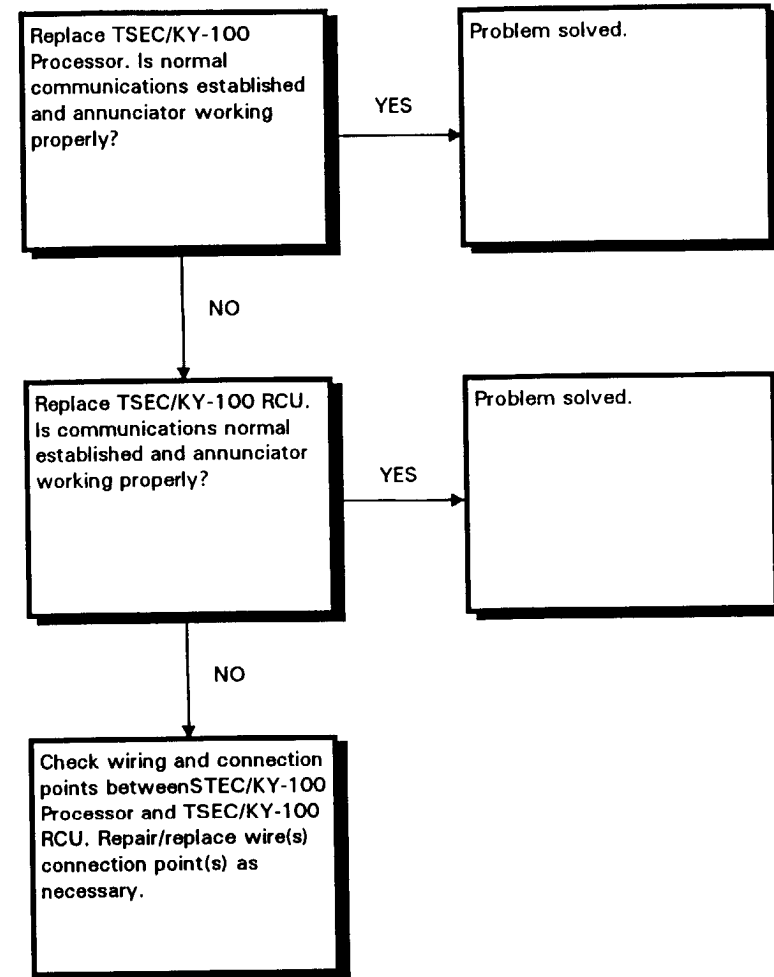

END OF TASK

ALPHABETICAL INDEX

	<i>Task</i>	<i>Page</i>		<i>Task</i>	<i>Page</i>
A					
Absorber, Dynamic	2-2	2-19	APU System (Continued)		
AC Power System.....	9-2	9-53	Operational Check	15-1.5	15-16
Contactor, APU Generator			System Components	15-1.1	15-8
Contactor, External Power			Visual Check	15-1.4	15-14
Contactor, No. 1, No. 2 Generator			Electrical System	15-2	15-19
Control Panel, APU Generator			Block Diagram.....	15-2.4	15-29
Control Panel, No. 1, No. 2 Generator			Circuit Breaker - APU Cont "Norm"	15-2.7	15-32
Generator, APU			Circuit Breaker - APU Cont "Emerg"	15-2.7	15-32
Generator, No. 1, No. 2 AC			Components	15-2.3	15-28
Monitor, External Power			Control Diode	15-2.11	15-41
Receptacle, External Power, AC			Electrical Schematic Diagram.....	15-2.5	15-30
Relay, Slave, APU Generator			Table 15-2.1 - APU Starting Sequence Failures	15-2.1	15-25
Transformer, Current, APU Generator			Table 15-2.2 - APU Systems Bite Indication Failures	15-2.2	15-26
Transformer, Current, Main			Troubleshooting Tasks List	15-2	15-21
Actuator, Cockpit Control Driver	11-2	11-9	Wiring Diagram	15-2.6	15-31
Actuator, Collective Control Drive	11-3	11-35	Fuel System.....	15-3	15-49
Actuator, Dual Differential Airspeed Hold	11-3	11-35	Block Diagram.....	15-3.2	15-54
Actuator, Integrated Lower Control	11-3	11-35	Components	15-3.1	15-53
Actuator, N1 (Without 74)	4-5	4-91	Component Tests		
Actuator, N2 (Without 74)	4-6	4-115	• Fault Relay (Table 15-3.2)	15-3.9	15-63
Actuator, Pitch Control Drive	11-3	11-35	• Fuel Boost Pump (Table 15-3.1)	15-3.8	15-62
Advanced Flight Control System	11-3	11-35	• Fuel Solenoid Valve (Table 15-3.1)	15-3.8	15-62
Actuator, Collective Control Drive			• Main Fuel Valve (Table 15-3.3)	15-3.10	15-64
Actuator, Dual Differential Airspeed Hold			• Start Fuel Valve (Table 15-3.3)	15-3.10	15-64
Actuator, Integrated Lower Control			Electrical Schematic	15-3.4	15-56
Actuator, Pitch Control Drive			Fault Relay	15-3.9	15-63
Brake, Magnetic			Fuel Boost Pump	15-3.8	15-62
Computer, AFCS			Fuel Solenoid Valve	15-3.8	15-62
Control Panel, AFCS			Main Fuel Valve	15-3.10	15-64
Grip, Cyclic			Piping Diagram	15-3.3	15-55
Grip, Thrust			Start Fuel Valve	15-3.10	15-64
Indicator, Cyclic Trim			Table 15-3.1 - Component Tests - Fuel Boost Pump	15-3.8	15-62
Relay, Roll Erect Cutout			Table 15-3.1 - Component Tests - Fuel Solenoid Valve	15-3.8	15-62
Transducer, Control Position			Table 15-3.2 - Component Tests - Fault Relay	15-3.9	15-63
Altitude Voice Warning System (AVWS)	18-2	18-47	Table 15-3.3 - Component Tests - Main Fuel Valve	15-3.10	15-64
Air Data Transducer (ADT)	16-4	16-14	Table 15-3.3 - Component Tests - Start Fuel Valve	15-3.10	15-64
Anticollision Light (AVIM)	9-20		Troubleshooting Tasks List	15-3	15-51
Anticollision Lights System	9-6	9-151	Hydraulic System - APU	15-4	15-65
Light, Anticollision			Block Diagram.....	15-4.2	15-69
APU Hydraulic Starting System.....	15-4	15-65	Charging Accumulator Flow Diagram.....	15-4.4	15-72
Solenoid Valve, APU Hydraulic Start			Components	15-4.1	15-68
APU System.....	15	15-1	Major Interconnecting APU Hydraulic System Schematic	15-4.3	15-70
Airframe Interface System.....	15-1	15-5	Operation Check	15-4.8	15-76
Overall Electrical Cabling Interconnection of APU System Components, "Interfaced" to Main Engine "Starter" Components	15-1.2	15-10	Pump Flow Diagram	15-4.6	15-74
Overall Piping Interrelationship of APU System Components, Interfaced to Main Engine Starter Components	15-1.3	15-13	Solenoid Valve, Hydraulic Start	15-4.10	15-80
			Troubleshooting Tasks List	15-4.5	15-73
			Visual Check	15-4.7	15-75

	<i>Task</i>	<i>Page</i>
Control Box, Power Steering.....	7-5	7-153
Control Cable, Hoist.....	14-1	14-1
Control Diode, APU.....	15-2.11	15-41
Control, heater Fan Over-Run.....	13-1	13-1
Control Panel, AFCS.....	11-3	11-35
Control Panel, APU Generator.....	9-2	9-53
Control Panel, Hoist/Cargo.....	16-1	16-1
Control Panel, No. 1 Generator.....	9-2	9-53
Control Panel, No. 2 Generator.....	9-2	9-53
Control, Quadrant, Engine Condition (Without 74).....	4-5	4-91
Control, Quadrant, Engine Condition (With 74).....	4-11	4-247
Control Valve, Swivel Lock.....	7-4	7-139
Control Valve, Wheel Brake.....	7-6	7-175
Controller, Temperature.....	13-1	13-1
Controller, Windshield Temperature.....	12-1	12-1
Copilot Flight Instrument Panel Lights.....	9-10	9-187
Light, Airspeed Indicator		
Light, Clock		
Light, Dual Engine Torque meter Indicator (Without 74)		
Light, Radar Alt Dim Control Panel		
Light, Rate of Climb Indicator		
Light, Turn and Slip Indicator		
Resistor, Copilot Instrument Light Dim		
Transformer, Copilot 28V-5V		
Copilot's Display Unit (CDU).....	16-4	16-143
Countermeasures Dispenser System.....	16-5	16-181
Digital Control Display Unit		
Dispenser		
Programmer		
Safety Switch		
Sequencer		
Cowling, Anti-Ice (Without 74).....	4-2	4-31
Cruise Guide Indicating System.....	8-12	8-295
Indicator, Cruise Guide		
Link, LCT Connecting		
Signal Conditional, Cruise Guide		
Signal Processor, Cruise Guide		
Switch, Cruise Guide		
Cyclic Switch, Heater.....	13-1	13-1
D		
DC Power System.....	9-1	9-1
Battery		
Charger, Battery		
Indicator Light, Battery Charging		
Indicator Light, Charge Complete		
Receptacle, External Power, DC		
Relay, Battery		
Relay, Crosstie		
Relay, Essential DC Bus		
Relay, External Power		
Relay, Reverse Current Cutout		
Relay, Switched Battery		
Relay, Transformer Rectifier Fail		
Transformer Rectifier		

	<i>Task</i>	<i>Page</i>
Debris Screen.....	6-2	6-25
Detection Control Assembly, Engine Fire.....	12-2	12-29
Detector, Chip.....	8-9	8-149
Dispenser Control, Flare.....	16-2	16-69
Doppler/GPS Navigation System.....	18-3	18-61
CDU Display is not GO ALL.....		18-79
CDU does not display DOWNLOAD WAYPTS IN PROCESS during waypoint loading.....		18-88
CDU MAL LAMP and LED segments are not illuminated.....		18-77
EDE LIT panel does not light or vary.....		18-75
GPS Alert indicator does not illuminate.....		18-84
GPS does not zeroize.....		18-92
GPS HAVEQUICK Timing not working.....		18-94
Indications on the four-line display and HIS are not the same.....		18-90
Present position not displayed on CDU.....		18-86
Drain, Pilot Static.....	8-1	8-1
Dynamic Absorber System.....	2-2	2-19
Absorber, Dynamic		
Test Box, Self		
E		
Emergency Exit Lights System.....	17-1	17-1
Exit Light Assembly, Emergency		
Switch Assembly, Inertial		
Engine Accessory Gearbox Chip Detector System (Without 74).....	4-7	4-177
Engine Accessory Gearbox Chip Detector System (With 74).....	4-13	4-313
Engine Anti-Icing System (Without 74).....	4-2	4-31
Cowling, Anti-Ice		
Engine Fuel Flow Indicating System.....	8-16	8-343
Indicator, Dual Fuel flow		
Power Supply		
Transducer, Fuel Flow		
Engine Fuel Shutoff and Cross feed Valves System.....	10-1	10-1
Light, Cross feed Fuel Valve Indicator		
Light, Engine Fuel Valve Indicator		
Valve, Cross feed Fuel		
Valve, Engine Fuel		
Engine Hydraulic Starting System.....	15-5	15-96
Solenoid Valve, Engine Start		
Engine Low Oil Level Warning System (Without 74).....	4-3	4-43
Engine Low Oil Level Warning System (With 74).....	4-9	4-213
Engine Oil Pressure Indicating System.....	8-3	8-43
Indicator, Engine Oil Pressure		
Transmitter, Engine Oil Pressure		
Engine Oil Temperature Indicating System.....	8-4	8-61
Bulb, Engine Oil Temperature		
Indicator, Engine Oil Temperature		
Engine Start and Ignition System (Without 74).....	4-4	4-51
Panel, Engine Start		
Relay, Engine Start		
Relay, Engine Start and Temperature		
Solenoid Valve, Engine Start		

	<i>Task</i>	<i>Page</i>
Engine Start and Ignition System (With 74)	4-10	4-221
Digital Engine Control Unit (DECU)		
Panel FADEC Control		
Relay, Engine Start		
Solenoid Valve, Engine Start		
Exit Light Assembly, Emergency	17-1	17-1
Extended Range Fuel System (ERFS II) (With 84)	10-4	10-179
ERFS II Fuel Control Panel		
ERFS II Refuel Valve		
Refuel Station Switch		
External Cargo Hook System	16-1	16-1
Control Panel, Hoist/Cargo		
Relay Box Assembly, Dual Hook		
Relay Box Assembly, Emergency Hook Release		
Hook Assembly, External Cargo, Fwd and Aft		
Hook Assembly, Mid		
Solenoid, Cargo Hook, Emergency Release		
Solenoid, Cargo Hook, Normal Release		
Extinguisher Bottle, Fire	12-3	12-53
F		
Fan Avionic Cooling	9-19	9-341
Fan, Heater	13-1	13-1
Filter, Auxiliary	6-2	6-25
Filter Detection System	12-2	12-29
Detection Control, Engine Fire		
Fire Sensing Element, Engine		
Light, Fire Detection, Engine		
Switch, Fire Detector Test		
Fire Extinguishing System	12-3	12-53
Extinguishing Bottle, Fire		
Switch, Fire Agent Selector		
Switch, Fire Handle, Engine		
Fire Sensing Element, Engine	12-2	12-29
Flare, Dispenser System	16-2	16-69
Bypass Switch Panel, Remote		
Dispenser Control, Fire		
Programmer and Dispenser		
Relay, Flare Dispenser		
Timer		
Flight Control Hydraulic System	7-1	7-1
Solenoid Valve, Boost Pressure		
Switch, Boost Pressure		
Floodlight, Console	9-13	9-229
Floodlight, Instrument Panel	9-13	9-229
Floodlight, Overhead Panel	9-13	9-229
Formation Lights System	9-5	9-139
Light, Formation		
Resistor, Formation Lights		

	<i>Task</i>	<i>Page</i>
Forward Transmission Oil Level Check Light	9-7	9-159
Light, Oil Level Check		
Switch, Oil Level Check Light		
Fuel Boost Pumps System	10-2	10-35
Panel, Fuel Control		
Pump, Fuel		
Relay Box, Fuel Control		
Pressure Switch, Engine Fuel		
Fuel Control, Heater	13-1	13-1
Fuel Pump, APU	15-3.8	15-62
Full Authority Digital Engine Control (FADEC) (With 74)	4-12	4-255
Digital Engine Control Unit (DECU)		
Control Quadrant, Engine Condition		
Hydro-Mechanical Unit (HMU)		
Panel, FADEC Control		
Relay, FADEC, Panel		
Transducer, Thrust Control Position (CPT)		
G		
Gas Producer Control System	4-5	4-91
Actuator, N1		
Control Box, N1		
Control Quadrant, Engine Condition		
Gas Producer Tachometer System	8-2	8-29
Generator, Gas Producer Tachometer		
Indicator, Gas Producer Tachometer		
Generator, AC	9-2	9-53
Generator, APU	9-2	9-53
Generator, Gas Producer Tachometer	8-2	8-29
Generator, No. 1, No. 2 AC	9-2	9-53
Grip Cyclic	11-3	11-35
Grip, Thrust	11-3	11-35
H		
Hand pump, Hydraulic	7-10	7-235
Harness, 10 Point Thermocouple	8-5	8-73
Heads Up Display (HUD) System	16-4	16-143
Air Data Transducer (ADT)		
Converter Control Unit (CCU)		
Copilot's Display Unit (CDU)		
Inclinometer		
Pilot's Display Unit (PDU)		
Signal Data Converter (SDC)		
Heating and Ventilating System	13-1	13-1
Control, Heater Fan Over-Run		
Controller, Temperature		
Cycling Switch, Heater		
Fan, Heater		
Fuel Control Heater		
Igniter, Heater		
Overheat Protector, Heater		
Pressure Switch, Differential		
Relay, Box, Heater		

	<i>Task</i>	<i>Page</i>
Heating and Ventilating System (Continued)		
Relay, Heater		
Relay, Heater Fan Control		
Solenoid, Master Fuel Valve		
Switch, Cabin Thermostat		
HF Liaison Facility	18-4	18-97
AN/ARC-200		
TSEC/KY-1 00		
Hook Assembly, External Cargo, Fwd and Aft	16-1	16-1
Hook Assembly, External Cargo, Mid	16-1	16-1
Hydraulic Pressure Indicating System	8-7	8-121
Indicator, Hydraulic Pressure		
Panel, Hydraulic		
Transmitter, Hydraulic Pressure		
Hydraulic Oil Temperature Indicating System.....	8-8	8-135
Bulb, Hydraulic Temperature		
Indicator, Hydraulic Temperature		
Hydro-Mechanical Unit (With 74).....	4-12	4-255
I		
Igniter, Heater.....	13-1	13-1
Inclinometer	16-4	16-143
Indicator, Airspeed	8-1	8-1
Indicator, Altimeter	8-1	8-1
Indicator Assembly, Stick Position.....	8-12	8-295
Indicator, Cruise Guide.....	8-12	8-295
Indicator, Cyclic Trim.....	11-3	11-35
Indicator, Dual Fuel Flow.....	8-16	8-343
Indicator, Dual Torque	8-6	8-101
Indicator, Engine Chip Detector (Without 74).....	4-7	4-177
Indicator, Engine Chip Detector (With 74).....	4-13	4-313
Indicator, Engine Oil Pressure	8-3	8-43
Indicator, Engine Oil Temperature	8-4	8-61
Indicator, Fuel Quantity	8-11	8-259
Indicator, Gas Producer Tachometer	8-2	8-29
Indicator, Flight Control Hydraulic Reservoir Level	8-14	8-319
Indicator, Hydraulic Pressure	8-7	8-121
Indicator, Hydraulic Temperature	8-8	8-135
Indicator, Hydraulic Temperature	8-10	8-213
Indicator, Utility Hydraulic Reservoir Level	8-14	8-319
Indicator Light, Battery Charging	9-1	9-1
Indicator Light, Charge Complete	9-1	9-1
Indicator, Ptit	8-5	8-73
Indicator, Rotor Tachometer	8-15	8-333
Indicator, Transmission Chip Detector	8-14	8-319
Indicator, Transmission Debris Screen	8-14	8-319
Indicator, Transmission Oil Pressure	8-9	8-149
Indicator, Transmission Oil Temperature	8-9	8-149
Indicator, Transmission Overtemp	8-14	8-319

	<i>Task</i>	<i>Page</i>
Indicator, Turn and Slip	8-13	8-309
Indicator, Vertical Speed.....	8-1	8-1
Igniter, Heater	13-1	13-1
Inverter	10-3	10-123
J		
Junction Box, Torquemeter	8-6	8-101
L		
Landing Lights (Search Lights) System	9-4	9-107
Searchlight		
Light, Aft Cyclic Trim Indicator	9-9	9-179
Light, Anti-Collision	9-6	9-151
Light, Aux Oil Pressure.....	8-14	8-319
Light, Cabin	9-15	9-259
Light, Clock, Copilot Panel	9-10	9-187
Light, Clock, Pilot Panel	9-8	9-167
Light, Cockpit Dome.....	9-14	9-247
Light, Cockpit Utility	9-14	9-247
Light, Crossfeed Fuel Valve Indicator	10-1	10-1
Light, Cruise Guide Indicator	9-8	9-167
Light, Dual Engine Torquemeter Indicator	9-10	9-187
Light, Electric Power Panel	9-11	9-199
Light, Emergency Power (Without 74).....	8-5	8-73
Light, Engine Fuel Valve Indicator	10-1	10-1
Light, Engine Gas Producer Tachometer	9-9	9-179
Light, Engine Oil Pressure Indicator	9-9	9-179
Light, Engine Oil Temperature Indicator	9-9	9-179
Light, Engine Start Panel (Without 74).....	9-11	9-199
Light, Engine Trim Panel (Without 74).....	9-12	9-213
Light, Engine Turbine Inlet Temp Indicator	9-9	9-179
Light, Fire Handle Warning Panel	9-9	9-179
Light, Engine Fire Detection	12-2	12-29
Light, Formation.....	9-5	9-139
Light, Fuel Quantity Indicator	9-9	9-179
Light, Fuel Quantity Switch.....	9-9	9-179
Light, Fwd Cyclic Trim Indicator	9-9	9-179
Light, Fwd XMSN Oil Level Check	9-7	9-159
Light, Green Position	9-3	9-99
Light, Ground Contact Indicator	3-1	3-2.4
Light, Hydraulic Filter Change	8-14	8-319
Light, Hydraulic Power Panel	9-11	9-199
Light, Hydraulic Pump Change	8-14	8-319
Light, Master Caution.....	9-18	9-321
Light, Master Caution Switch Panel	9-9	9-179
Light, Main Oil Pressure	8-14	8-319
Light, OVHD Fuel Control Panel	9-11	9-199
Light, OVHD Lighting Control Panel	9-11	9-199
Light, OVHD Switch Panel, Anti-Ice	9-11	9-199
Light, OVHD Switch Panel, Heating	9-11	9-199

	<i>Task</i>	<i>Page</i>
Light, OVHD Switch Panel, Lighting	9-11	9-199
Light, Radar Alt Dim Cont Panel	9-88	9-167
Light, Ramp	9-15	9-259
Light, Rate of Climb Indicator	9-10	9-187
Light, Red Position	9-3	9-99
Lighting System		
Anticollision	9-6	9-151
Cabin and Ramp	9-15	9-259
Cargo Hook	9-23	9-375
Cockpit Dome and Utility	9-14	9-247
Console	9-12	9-213
Formation	9-5	9-139
Forward Transmission Oil Level Check	9-7	9-159
Instrument Panel, Center	9-9	9-179
Instrument Panel, Copilot	9-10	9-187
Instrument Panel, Pilot	9-8	9-167
Landing	9-4	9-107
Master Caution	9-18	9-321
Overhead Panel	9-11	9-199
Position	9-3	9-99
Secondary Cockpit	9-13	9-229
Troop Warning	9-16	9-277
Light, Transmission Oil Pressure Indicator	9-9	9-179
Light, Transmission Oil Pressure Select Switch	9-9	9-179
Light, Transmission Oil Temperature Indicator	9-9	9-179
Light, Transmission Oil Temperature Select Switch	9-9	9-179
Light, Troop Jump	9-16	9-277
Light, Troop Jump Signal	9-16	9-277
Light, Turn and Slip Indicator	9-10	9-187
Light, White Position	9-3	9-99
Link, LCT Connecting	8-12	8-295
M		
Maintenance Panel	8-14	8-319
Indicator, Engine Chip Detector		
Indicator, Ground Contact		
Indicator, Hydraulic, Pressure		
Indicator, Hydraulic Flight Control Reservoir Level		
Indicator, Utility Hydraulic Reservoir Level		
Indicator, Hydraulic Temperature		
Indicator, Transmission Chip Detector		
Indicator, Transmission Debris Screen		
Indicator, Transmission Overtemp		
Light, Aux Oil Pressure		
Light, Hydraulic Filter Change		
Light, Hydraulic Pump Change		
Light, Main Oil Pressure		
Switch, Hydraulic Level Check		
Switch, No. 1, or No. 2 Flight Control		
Switch, Test		

	<i>Task</i>	<i>Page</i>
Master Caution Lights System	9-18	9-321
Capacitor, Caution Panel Filter		
Caution Panel, Master		
Light, Master Caution		
Relay, Dimming Lockout		
Relay, Caution Light Dimming		
Switch, Caution Lights Dim/Bright		
Switch, Caution Lights Test		
Master Caution Panel (AVIM) (Without 74)	9-21	9-359
Monitor, External Power	9-2	9-53
Motor, Windshield Wiper	12-4	12-71
O		
Overhead Panel Lights System	9-11	9-199
Light, Electrical Power Panel		
Light, Hydraulic Power Panel		
Light, Engine Start Panel (Without 74)		
Light, OVHD Fuel Control Panel		
Light, OVHD Lighting Control Panel		
Light, OVHD Switch Panel, Anti-Ice		
Light, OVHD Switch Panel, Heating		
Light, OVHD Switch Panel, Lighting		
Overheat Protector, Heater	13-1	13-1
P		
Panel, Fuel Control	10-2	10-35
Panel, Fuel Quantity Pre-Check	8-11	8-259
Panel, Hoist Operator	14-1	14-1
Panel, Hydraulic	8-7	8-121
Panel, Emergency Power (Without 74)	8-5	8-73
Panel, Engine Start (Without 74)	4-4	4-51
Panel, FADEC Control (With 74)	4-12	4-255
Panel, Precheck	10-3	10-123
Phase Detector, Magnetic	5-2	5-5
Pilot Flight Instrument Panel Lights	9-8	9-167
Compass, Standby		
Light, Airspeed Indicator		
Light, Clock		
Light, Cruise Guide Indicator		
Light, Dual Engine Torquemeter		
Light, Radar Alt Dim Cont Panel		
Light, Rate of Climb Indicator		
Light, Turn and Slip Indicator		
Resistor, Pit Inst Lts Dim		
Compass, Standby		
Transformer, Pilot Instruments		
Pitot Static System	8-1	8-1
Drain, Pitot Static		
Indicator, Airspeed		
Indicator, Altimeter		

	<i>Task</i>	<i>Page</i>
Pitot Static System (Continued)		
Indicator, Vertical Speed		
Port, Sideslip Sense		
Port, Static		
Tube, Airspeed		
Port, Sideslip Sense.....	8-1	8-1
Port, Static	8-1	8-1
Position Lights System.....	9-3	9-99
Light, Green Position		
Light, Red Position		
Light, White Position		
Resistor, Navigation Lights		
Power Supply	8-16	8-343
Power Turbine (N2) Control System (Without 74).....	4-6	4-115
Actuator, N2		
Control Box, Engine		
Relay, Emergency Engine Trim		
Relay, Engine Trim		
Resistor, Droop Eliminator		
Resistor, Engine Trim, Adjustable		
Resistor, Engine Trim, Fixed		
Power Turbine (N2) Control System (With 74).....	4-12	4-255
Power Turbine Inlet Temperature System (Without 74).....	8-5	8-73
Harness, 10 Point Thermocouple		
Indicator, Ptit		
Light, Emergency Power		
Panel, Emergency Power		
Switch, Emergency Power		
Power Turbine Inlet Temperature System (With 74).....	8-5	8-73
Harness, Point Thermocouple		
Indicator, PTIT		
Power Steering Assembly, Aft Landing Gear.....	7-5	7-153
Power Steering System.....	7-5	7-153
Control Box, Power Steering		
Power Steering Assembly, Aft Landing Gear		
Relay, Power Steering		
Solenoid Valve, Power Steering		
Power Supply, Engine Torquemeter (Without 74).....	8-6	8-101
Power Supply, Engine Torquemeter Signal Processor/ (With 74).....	8-6	8-101
Pressure Switch, Differential.....	13-1	13-1
Pressure Switch, Engine Fuel.....	10-2	10-35
Probe, Transmission Temperature	8-9	8-149
Programmer and Dispenser.....	16-2	16-69
Pump, Fuel.....	10-2	10-35
R		
Receptacle, AC, External Power.....	9-2	9-53
Receptacle, DC.....	9-17	9-303
Receptacle, DC, External Power	9-1	9-1

	<i>Task</i>	<i>Page</i>
Receptacle, Utility, 1 Phase	9-17	9-303
Receptacle, 28VDC PDP, Utility	9-17	9-303
Receptacle, 3 Phase, Utility	9-17	9-303
Relay, APU Fault	15-3.9	15-63
Relay, APU Generator, Slave	9-2	9-53
Relay, Avionics Cooling	9-19	9-341
Relay Box Assembly, Dual Hook	16-1	16-1
Relay Box Assembly, Emergency Hook Release	16-1	16-1
Relay, Battery	9-1	9-1
Relay Box, Fuel Control	10-2	10-35
Relay Box, Heater	13-1	13-1
Relay, Red, Cabin Light	9-15	9-259
Relay, Caution Light Dimming	9-18	9-321
Relay, Cockpit Floodlight	9-13	9-229
Relay, Crosstie	9-1	9-1
Relay, Dimming Lockout	9-18	9-321
Relay, Emergency Engine Trim (Without 74).....	4-6	4-115
Relay, Engine Start and Ignition (Without 74).....	4-4	4-51
Relay, Engine Trim (Without 74)	4-6	4-115
Relay, Essential DC Bus	9-1	9-1
Relay, External Power	9-1	9-1
Relay, Flare Dispenser	16-2	16-69
Relay, Heater	13-1	13-1
Relay, Heater Fan Control	13-1	13-1
Relay, Instrument Light Transformer	9-13	9-229
Relay, Jump Light	9-16	9-277
Relay, Panel, FADEC (With 74).....	4-10	4-221
Relay, Power Steering	7-5	7-153
Relay, Reverse Current Cutout	9-1	9-1
Relay, Roll Erect Cutout	11-3	11-35
Relay, Switched Battery	9-1	9-1
Relay, Transformer Rectifier Fail	9-1	9-1
Relay, Troop Light Dimming	9-16	9-277
Relay, Utility Hydraulic Isolate	7-2	7-71
Relay, White, Cabin Light	9-15	9-259
Relay, Windshield Anti-Ice	12-1	12-1
Resistor, Center Instrument Panel Light	9-9	9-179
Resistor, Copilot Instrument Light Dim	9-10	9-187
Resistor, Droop Eliminator (Without 74)	4-6	4-115
Resistor, Engine Trim Adjustable (Without 74)	4-6	4-115
Resistor, Engine Trim Fixed (Without 74)	4-6	4-115
Resistor, Formation Lights	9-5	9-139
Resistor, Fuel Flow Indicator	9-9	9-179
Resistor, Jump Light Relay	9-16	9-277
Resistor, Jump Signal Dim	9-16	9-277
Resistor, Navigation Lights	9-3	9-99
Resistor, Pit Inst Lts Dim	9-8	9-167
Resistor, Windshield Wiper Motor	12-4	12-71

	<i>Task</i>	<i>Page</i>
Rotor Blade Tracking and Balancing System.....	5-2	5-5
Phase Detector, Magnetic		
Rotor Tachometer System	8-15	8-333
Generator, AC		
Indicator, Rotor Tachometer		
S		
Searchlight	9-4	9-107
Secondary Cockpit Lights System	9-13	9-229
Floodlight, Console		
Floodlight, Instrument Panel		
Floodlight, OVHD Panel		
Relay, Cockpit Floodlight		
Relay, Instrument Light Transformer		
Selector Switch, Fuel Quantity	8-11	8-259
Selector Switch, Oil Pressure	8-9	8-149
Sensor, Thermistor.....	8-11	8-259
Selector Switch, Transmission Oil Temperature	8-9	8-149
Signal Conditioner, Cruise Guide	8-12	8-295
Signal Data Converter (SDC).....	16-4	16-143
Signal Processor, Cruise Guide	8-12	8-295
Signal Processor/Power Supply, Engine Torquemeter (With 74)	8-6	8-101
Single Point Pressure Refueling System	10-3	10-123
Inverter		
Panel, Fuel Control		
Panel, Precheck		
Switch Box, Fuel Quantity		
Valve, Fuel Level Control		
Valve, Fuel Level Shutoff		
Solenoid, Brake Release	14-1	14-1
Solenoid Valve, Boost Pressure	7-1	7-1
Solenoid, Cable Cutter	14-1	14-1
Solenoid, Cargo Hook Emergency Release	16-1	16-1
Solenoid, Cargo Hook, Normal Release	16-1	16-1
Solenoid, Hoist Control Valve	14-1	14-1
Solenoid, Master Fuel Valve	13-1	13-1
Solenoid Valve, APU Hydraulic Start	15-4.10	15-80
Solenoid Valve, Engine Pilot (Without 74)	4-4	4-51
Solenoid Valve, Engine Pilot (With 74)	4-10	4-221
Solenoid Valve, Pilot	7-2	7-71
Solenoid Valve, Power Steering	7-5	7-153
Solenoid Valve, Power Transfer Unit	7-2	7-71
Solenoid Valve, Ramp	7-3	7-119
Switch Assembly, Inertia	17-1	17-1
Switch, Boost Pressure	7-1	7-1
Switch Box, Fuel Quantity	8-11	8-259
Switch, Cabin Thermostat	13-1	13-1
Switch, Caution Lights Dim/Bright	9-18	9-321
Switch, Caution Lights Test	9-18	9-321
Switch, Cruise Guide	8-12	8-295

	<i>Task</i>	<i>Page</i>
Switch, Emergency Power (Without 74)	8-5	8-73
Switch, Fire Agent Selector	12-3	12-53
Switch, Fire Detector Test	12-2	12-29
Switch, Fire Handle, Engine	12-3	12-53
Switch, Hydraulic Level Check	8-14	8-319
Switch, No. 1, No. 2 Flight Control	8-14	8-319
Switch, Oil Pressure.....	8-9	8-149
Switch, Oil Level Check Light	9-7	9-159
Switch, Parking Brake Handle	7-6	7-175
Switch, Pressure, Utility System	7-2	7-71
Switch, Rotary Windshield Wiper	12-4	12-71
Switch, Test	8-14	8-319
Swivel Locks System	7-4	7-139
Control Box, Power Steering		
Control Valve, Swivel Lock		
T		
Tank Unit, Fuel Quantity Indicating	8-11	8-259
Test Box, Self	2-2	2-19
Timer	16-2	16-59
Transducer, Control Position	11-3	11-35
Transducer, Control Position, Thrust (With 74)	4-12	4-255
Transducer, Fuel Flow	8-16	8-343
Transducer, Oil Pressure	8-9	8-149
Transformer, Copilot 28V-5V	9-10	9-187
Transformer, Pilot Instruments	9-8	9-167
Transformer, Console System	9-12	9-213
Transformer, Current, APU Generator	9-2	9-53
Transformer, Current, Main	9-2	9-53
Transformer Rectifier	9-1	9-1
Transmission Chip Detectors and Debris Screens System	6-2	6-25
Chip Detector		
Chip Detector and Indicating Screen		
Debris Screen		
Filter, Auxiliary		
Filter, Impending Bypass		
Transmission Lubrication Systems	6-1	6-1
Transmission Oil Pressure Indicating and Warning System	8-9	8-149
Indicator, Transmission Oil Pressure		
Selector Switch, Oil Pressure		
Switch, Oil Pressure		
Transducer, Oil Pressure		
Transmission Oil Temperature Indicating and Warning System.....	8-10	8-213
Detector, Chip		
Indicator, Transmission Oil Temperature		
Probe, Transmission Temperature		
Selector Switch, Transmission Oil Temperature		
Transmitter, Engine Oil Pressure	8-3	8-43
Transmitter, Hydraulic Pressure	8-7	8-121
Transmitter Unit, Dual Control.....	8-11	8-259

By Order of the Secretary of the Army:

E. C. MEYER
General, United States Army
Chief of Staff

Official:

ROBERT M. JOYCE
Major General, United States Army
The Adjutant General

DISTRIBUTION:

To be distributed in accordance with DA Form 12-31, Organizational Maintenance requirements for CH-47B/C & D aircraft.

* U.S. GOVERNMENT PRINTING OFFICE : 1995 - 388-421 (42150)

These are the instructions for sending an electronic 2028

The following format must be used if submitting an electronic 2028. The subject line must be exactly the same and all fields must be included; however only the following fields are mandatory: 1, 3, 4, 5, 6, 7, 8, 9, 10, 13, 15, 16, 17, and 27.

From: "Whomever" <whomever@wherever.army.mil>

To: 2028@redstone.army.mil

Subject: DA Form 2028

1. **From:** Joe Smith
2. **Unit:** home
3. **Address:** 4300 Park
4. **City:** Hometown
5. **St:** MO
6. **Zip:** 77777
7. **Date Sent:** 19-OCT-93
8. **Pub no:** 55-2840-229-23
9. **Pub Title:** TM
10. **Publication Date:** 04-JUL-85
11. **Change Number:** 7
12. **Submitter Rank:** MSG
13. **Submitter FName:** Joe
14. **Submitter MName:** T
15. **Submitter LName:** Smith
16. **Submitter Phone:** 123-123-1234
17. **Problem:** 1
18. **Page:** 2
19. **Paragraph:** 3
20. **Line:** 4
21. **NSN:** 5
22. **Reference:** 6
23. **Figure:** 7
24. **Table:** 8
25. **Item:** 9
26. **Total:** 123
27. **Text:**

This is the text for the problem below line 27.

RECOMMENDED CHANGES TO PUBLICATIONS AND BLANK FORMS For use of this form, see AR 25-30; the proponent agency is ODISC4.						Use Part II (reverse) for Repair Parts and Special Tool Lists (RPSTL) and Supply Catalogs/Supply Manuals (SC/SM)	DATE 8/30/02
TO: (Forward to proponent of publication or form)(Include ZIP Code) Commander, U.S. Army Aviation and Missile Command ATTN: AMSAM-MMC-MA-NP Redstone Arsenal, AL 35898						FROM: (Activity and location)(Include ZIP Code) MSG, Jane Q. Doe 1234 Any Street Nowhere Town, AL 34565	
PART 1 - ALL PUBLICATIONS (EXCEPT RPSTL AND SC/SM) AND BLANK FORMS							
PUBLICATION/FORM NUMBER TM 9-1005-433-24						DATE 16 Sep 2002	TITLE Organizational, Direct Support, And General Support Maintenance Manual for Machine Gun, .50 Caliber M3P and M3P Machine Gun Electrical Test Set Used On Avenger Air Defense Weapon System
ITEM NO.	PAGE NO.	PARA-GRAPH	LINE NO. *	FIGURE NO.	TABLE NO.	RECOMMENDED CHANGES AND REASON	
1	WP0005 PG 3		2			Test or Corrective Action column should identify a different WP number.	
EXAMPLE							
<i>* Reference to line numbers within the paragraph or subparagraph.</i>							
TYPED NAME, GRADE OR TITLE MSG, Jane Q. Doe, SFC				TELEPHONE EXCHANGE/AUTOVON, PLUS EXTENSION 788-1234		SIGNATURE	

TO: (Forward direct to addressee listed in publication) Commander, U.S. Army Aviation and Missile Command ATTN: AMSAM-MMC-MA-NP Redstone Arsenal, AL 35898	FROM: (Activity and location) (Include ZIP Code) MSG, Jane Q. Doe 1234 Any Street Nowhere Town, AL 34565	DATE 8/30/02
--	--	------------------------

PART II - REPAIR PARTS AND SPECIAL TOOL LISTS AND SUPPLY CATALOGS/SUPPLY MANUALS

PUBLICATION NUMBER			DATE	TITLE				
PAGE NO.	COLM NO.	LINE NO.	NATIONAL STOCK NUMBER	REFERENCE NO.	FIGURE NO.	ITEM NO.	TOTAL NO. OF MAJOR ITEMS SUPPORTED	RECOMMENDED ACTION

PART III - REMARKS (Any general remarks, corrections, or suggestions for improvement of publications and blank forms. Additional blank sheets may be used if more space is needed.)

EXAMPLE

TYPED NAME, GRADE OR TITLE MSG, Jane Q. Doe, SFC	TELEPHONE EXCHANGE/AUTOVON, PLUS EXTENSION 788-1234	SIGNATURE
---	--	-----------

RECOMMENDED CHANGES TO PUBLICATIONS AND BLANK FORMS						Use Part II (reverse) for Repair Parts and Special Tool Lists (RPSTL) and Supply Catalogs/Supply Manuals (SC/SM)	DATE
For use of this form, see AR 25-30; the proponent agency is ODISC4.							
TO: (Forward to proponent of publication or form)(Include ZIP Code) Commander, U.S. Army Aviation and Missile Command ATTN: AMSAM-MMC-MA-NP Redstone Arsenal, AL 35898						FROM: (Activity and location)(Include ZIP Code)	
PART 1 - ALL PUBLICATIONS (EXCEPT RPSTL AND SC/SM) AND BLANK FORMS							
PUBLICATION/FORM NUMBER						DATE	TITLE
ITEM NO.	PAGE NO.	PARA-GRAPH	LINE NO. *	FIGURE NO.	TABLE NO.	RECOMMENDED CHANGES AND REASON	
* Reference to line numbers within the paragraph or subparagraph.							
TYPED NAME, GRADE OR TITLE						TELEPHONE EXCHANGE/ AUTOVON, PLUS EXTENSION	SIGNATURE

TO: (Forward direct to addressee listed in publication) Commander, U.S. Army Aviation and Missile Command ATTN: AMSAM-MMC-MA-NP Redstone Arsenal, AL 35898	FROM: (Activity and location) (Include ZIP Code)	DATE
--	---	-------------

PART II - REPAIR PARTS AND SPECIAL TOOL LISTS AND SUPPLY CATALOGS/SUPPLY MANUALS

PUBLICATION NUMBER			DATE	TITLE				
PAGE NO.	COLM NO.	LINE NO.	NATIONAL STOCK NUMBER	REFERENCE NO.	FIGURE NO.	ITEM NO.	TOTAL NO. OF MAJOR ITEMS SUPPORTED	RECOMMENDED ACTION

PART III - REMARKS (Any general remarks or recommendations, or suggestions for improvement of publications and blank forms. Additional blank sheets may be used if more space is needed.)

--

TYPED NAME, GRADE OR TITLE	TELEPHONE EXCHANGE/AUTOVON, PLUS EXTENSION	SIGNATURE
----------------------------	--	-----------

The Metric System and Equivalents

Linear Measure

1 centimeter = 10 millimeters = .39 inch
 1 decimeter = 10 centimeters = 3.94 inches
 1 meter = 10 decimeters = 39.37 inches
 1 dekameter = 10 meters = 32.8 feet
 1 hectometer = 10 dekameters = 328.08 feet
 1 kilometer = 10 hectometers = 3,280.8 feet

Weights

1 centigram = 10 milligrams = .15 grain
 1 decigram = 10 centigrams = 1.54 grains
 1 gram = 10 decigrams = .035 ounce
 1 decagram = 10 grams = .35 ounce
 1 hectogram = 10 decagrams = 3.52 ounces
 1 kilogram = 10 hectograms = 2.2 pounds
 1 quintal = 100 kilograms = 220.46 pounds
 1 metric ton = 10 quintals = 1.1 short tons

Liquid Measure

1 centiliter = 10 milliliters = .34 fl. ounce
 1 deciliter = 10 centiliters = 3.38 fl. ounces
 1 liter = 10 deciliters = 33.81 fl. ounces
 1 dekaliter = 10 liters = 2.64 gallons
 1 hectoliter = 10 dekaliters = 26.42 gallons
 1 kiloliter = 10 hectoliters = 264.18 gallons

Square Measure

1 sq. centimeter = 100 sq. millimeters = .155 sq. inch
 1 sq. decimeter = 100 sq. centimeters = 15.5 sq. inches
 1 sq. meter (centare) = 100 sq. decimeters = 10.76 sq. feet
 1 sq. dekameter (are) = 100 sq. meters = 1,076.4 sq. feet
 1 sq. hectometer (hectare) = 100 sq. dekameters = 2.47 acres
 1 sq. kilometer = 100 sq. hectometers = .386 sq. mile

Cubic Measure

1 cu. centimeter = 1000 cu. millimeters = .06 cu. inch
 1 cu. decimeter = 1000 cu. centimeters = 61.02 cu. inches
 1 cu. meter = 1000 cu. decimeters = 35.31 cu. feet

Approximate Conversion Factors

<i>To change</i>	<i>To</i>	<i>Multiply by</i>	<i>To change</i>	<i>To</i>	<i>Multiply by</i>
inches	centimeters	2.540	ounce-inches	Newton-meters	.007062
feet	meters	.305	centimeters	inches	.394
yards	meters	.914	meters	feet	3.280
miles	kilometers	1.609	meters	yards	1.094
square inches	square centimeters	6.451	kilometers	miles	.621
square feet	square meters	.093	square centimeters	square inches	.155
square yards	square meters	.836	square meters	square feet	10.764
square miles	square kilometers	2.590	square meters	square yards	1.196
acres	square hectometers	.405	square kilometers	square miles	.386
cubic feet	cubic meters	.028	square hectometers	acres	2.471
cubic yards	cubic meters	.765	cubic meters	cubic feet	35.315
fluid ounces	milliliters	29.573	cubic meters	cubic yards	1.308
pints	liters	.473	milliliters	fluid ounces	.034
quarts	liters	.946	liters	pints	2.113
gallons	liters	3.785	liters	quarts	1.057
ounces	grams	28.349	liters	gallons	.264
pounds	kilograms	.454	grams	ounces	.035
short tons	metric tons	.907	kilograms	pounds	2.205
pound-feet	Newton-meters	1.356	metric tons	short tons	1.102
pound-inches	Newton-meters	.11296			

Temperature (Exact)

F	Fahrenheit temperature	5/9 (after subtracting 32)	Celsius temperature	C
---	---------------------------	-------------------------------	------------------------	---

